

# Back-up Light System

WIRING SYSTEM

## 25.Back-up Light System

### A: WIRING DIAGRAM

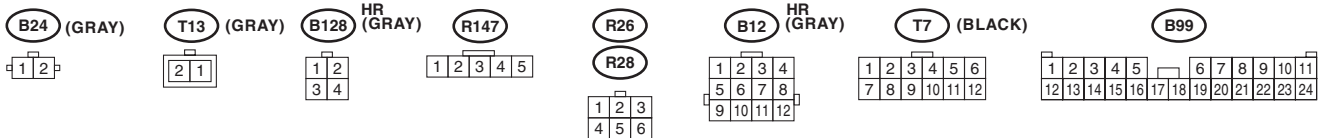
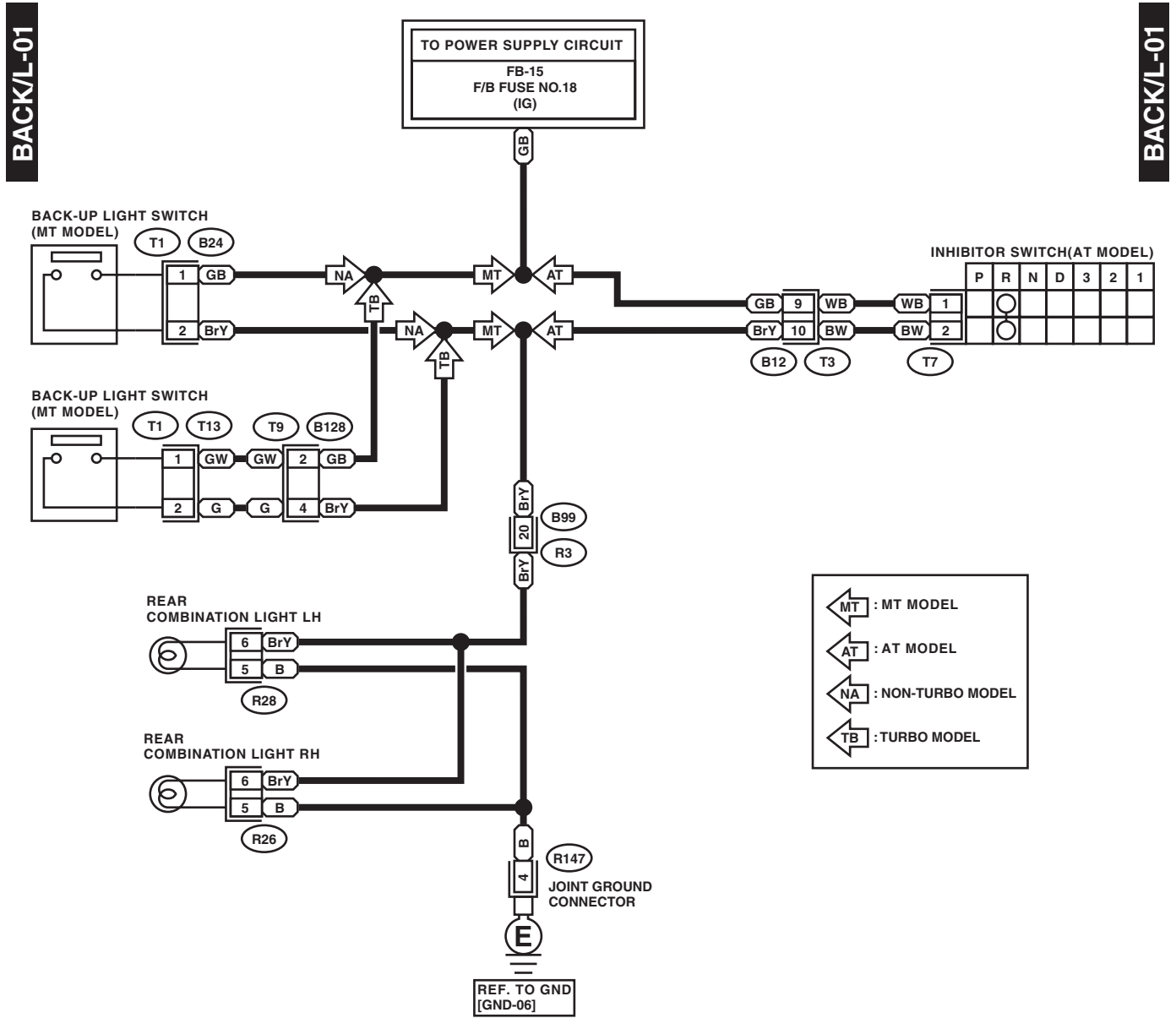

WI-15037