

SUBARU 



Technicians Reference Booklet

**Automatic
Transmissions
(4EAT)**

Module 302

Technical Training

**© Copyright 2001
Subaru of America, Inc.**

All rights reserved. This book may not be reproduced in whole or in part without the express permission of Subaru of America, Inc.

Subaru of America, Inc. reserves the right at any time to make changes or modifications to systems, procedures, descriptions, and illustrations contained in this book without necessarily updating this document. Information contained herein is considered current as of February 2001.

4EAT Transmission

Table of Contents

Introduction	8
General Overview	8
Features	10
Major Components	10
Lock-Up Torque Converter	10
Lock Up Operating Modes	11
Oil Pump Assembly	12
Oil Pump Operation	12
Transmission Gear Train	13
Operating Principles: Rear Gear Set	13
High Clutch and Reverse Clutch	14
Operating Principles: Front Gear Set	14
Band Servo Operation	14
Operating Principles: AWD	15
Transfer Clutch Assembly (AWD)	15
AWD component details	15
Final Drive	16
Oil Pump Housing Features	16
Differential Carrier Features	16
Hydraulic Control System	16
Valve Body	17
Accumulators	17
Accumulator Operation	17
Component Disassembly / Inspection	17
Drive Pinion	18
Reassembly	19
Clutch Reassembly Precautions	19
Differential Pinion Backlash	19
Transfer Clutch Valve Assembly	19
Transmission Reassembly	19
Torque Converter Case	19
Final Drive Pre-load & Backlash	19
Forward Clutch Installation	20
Reverse Clutch Drum End-Play	21
Total End-Play	21
Valve Body Precautions	22
Extension Case	22
Transmission Reinstallation	23
Electronic Control System	23
Overview	23
Transmission Control Unit	23
TCU Inputs	23
Legacy TCU Inputs	25
Maintenance Precautions	25
TCU Outputs	25
Shift Modes	26
Combination Meter Light Operation XT - 6 and L – Series	26
Late Model Combination Meter	27
Legacy, SVX, Impreza & Forester Lighting	27
Fail Safe System	27
Fail Safe Components and Failure Results	27
Self Diagnostic System	28
XT and L-Series Diagnostics	28

Continued on next page

February 2001

4EAT Transmission

1990 – 1994 Legacy, 1992 – 1995 SVX, 1993 – 1995 Impreza Diagnostics	28
Select Monitor Analysis	28
1995 – 1998 Legacy, 1996 – 1998 Impreza, 1996 – 1997 SVX, 1998 Forester, Diagnostics / OBD – II Vehicles	29
Trouble Codes	29
OBD - II	29
OBD - II Operation Overview	29
OBD - II purpose	29
Control Unit Networking	30
Troubleshooting and Adjustments	31
Preliminary Inspection	31
Gearshift Cable Adjustment	31
Stall Test	31
Stall Test Results	31
Time Lag Test	31
Time Lag Results:	32
Pressure Test	32
On Car Service/Adjustments	32
302 Module Lesson Plan Bulletins	34
302 Module Service Help-Line Updates	35
4EAT Valve Body Bolts	36

Slide Sequence

Slide No.	Description	Page No.
1	Title Slide (Four Speed Electronic Automatic Transmission) 4EAT	
2	Created By	
3	Teaching Aids	
4	4EAT Assembly	8
5	XT Selector Lever	8
6	Legacy Selector Lever	9
7	Gear Ratios	9
8	Transaxle Control Unit	9
9	Transmission Features	10
10	Title Slide (Major Components)	
11	Torque Convertors	10
12	Turbine Shafts	10
13	Torque Converter Components	
14	Piston & Cover	
15	Lock-up Clutch	
16	Lock-up Operation (Artwork)	11
17	Duty Solenoid "B" (Artwork)	11
18	Lock-up Control Valve (Artwork)	11
19	Torque Converter (Artwork)	11
20	Oil Pump Assembly	
21	Oil Pump Components	12
22	Oil Pump (Artwork)	12
23	Case Mating Surface Split Slide	
24	Transaxle Gear Train	
25	Rear Sun Gear	
26	Rear Planetary Set	13
27	Overrunning Clutch Hub	13
28	Forward Clutch Drum (Artwork)	13
29	OWC 1-2	
30	Low / Reverse Brake	
31	O.R.C. Hub Installed	
32	O.W.C. 3 -4 Installed	
33	Rear Internal Gear	
34	Rev. & High Clutches	14
35	High Clutches	
36	High Clutch Hub Bearings	14
37	Front Gear Set	14
38	Band & Servo	14
39	Servo Operation I (Artwork)	15
40	Servo Operation II (Artwork)	15
41	MPT Assembly	
42	MPT Clutch Drum	
43	Transfer Clutch & Drum	15
44	Title Slide (Final Drive)	
45	Differential Housing	
46	Oil Pump Housing	16
47	Oil Pump Cover Seals	
48	Differential Carrier	16
49	MPT Power Flow	
50	Title Slide (Lab Area)	
51	Title Slide (Hydraulic Control System)	

Slide Sequence

Slide No.	Description	Page No.
52	Valve Body	16
53	Upper Valve Body	
54	Lower Valve Body	
55	Accumulators	
56	Accumulator Operation	
57	Title Slide (Lab Area)	
58	Title Slide (Component Disassembly & Inspection)	
59	Oil Pump Assembly	17
60	Measuring Rotor	17
61	Measuring Pump Housing	18
62	Checking Starting Torque	18
63	Drive Pinion Assembly	18
64	Measuring "A"	18
65	Torque pinion Bearing	
66	Measuring "B"	19
67	Pinion Depth Formula	
68	Mount Pinion to Housing	
69	Title Slide (Reassembly)	
70	Carrier Installed	
71	Wrapping Stub Axles	
72	Lip Seal Retainer	
73	Zero State	20
74	Checking Backlash	20
75	Installing Retainer Assembly	
76	Forward Clutch Drum Installation	
77	Verifying Drum Installation	20
78	Measuring "M"	21
79	Measuring "m"	21
80	Measuring Total Clutch Pack Clearance	22
81	Selected Washers	
82	Valve Body Precautions	22
83	Measuring "I" (MPT)	22
84	Measuring "L" (MPT)	22
85	Selecting Bearing	
86	Lab Area (Reassembly)	
87	Title Slide (Electronic control System)	
88	Over view	
89	TCU Locations	
90	Throttle Sensor	23
91	Speed Sensor #1	24
92	Speed Sending Unit & Speedo Head	
93	Combination Meter	
94	Electric Speedometer System	
95	Inhibitor Switch	
96	Cruise Control	
97	Temp. Sensor	24
98	Forced FWD Switch	25
99	Legacy TCU Inputs	
100	Precautions	
101	TCU Outputs	
102	Shift Solenoids 1 & 2	25

4EAT Transmissions

Introduction

This Technicians Reference Booklet introduces the first generation of Subaru Four Speed Electronic Automatic Transmissions. It covers the components and their operation, its self-diagnostic system, troubleshooting, transmission removal, inspection, reassembly, and reinstallation procedures. The differences between the front-wheel-drive (FWD) and the four-wheel-drive (4WD) transmissions are also illustrated.

This booklet is designed to support the 4EAT Transmission Core Course and in no way should it be used to replace the service manual. The text and illustrations are derived from classroom instruction and lab participation.

Ample room has been left throughout the booklet for note taking. It is recommended that after completing the course, this booklet should be filed in your personal **Technical Training Reference Booklets Binder**, which is sold through Subaru of America Parts department (MSA5T0100B).

ALWAYS refer to the appropriate model year Subaru Service Manual and applicable service bulletins for all specifications and detailed service procedures. For your convenience, a service bulletin and Service Help Line Update index pages have been added to the back of this booklet.

General Overview

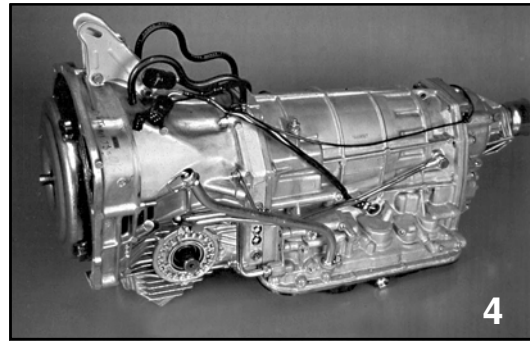

The 4EAT Transmission, is a 4 speed, microprocessor controlled transmission. It is not a 3 speed Transmission with overdrive. It features a lock-up torque converter, which locks up in all forward gears except 1st. It is available in FWD or Full Time 4WD.



The shift quadrant has been designed in accordance with the four forward speeds. In P, R, or N, there aren't any special features. With the selector in "D", the transmission shifts through all four gears. With the selector in "3", the transmission shifts 1, 2, 3. When the selector is in the "2" position, the transmission shifts through 1st and 2nd. If necessary, 3rd gear is computer selected to prevent the engine from over-revving.

Manual 1st gear is only activated when the 1-HOLD button is depressed and the shifter is in manually selected "2". This will provide engine braking. The transmission will up-shift through 2nd and 3rd if necessary, in order to prevent the engine from over-revving.

The 1-HOLD indicator is displayed on the combination meter when the button is activated. When the computer overrides the 1-HOLD gear selection the display will change.

4EAT Transmission



An enhanced version of the 4EAT was introduced with the 1990 MY Legacy. Although similar in design to the existing 4EAT, the shift quadrant is different. The Legacy 4EAT has a seven-position quadrant: P-R-N-D-3-2-1. The 1-HOLD button has been deleted and a manual button has been added.

When the selector is in 3rd range, manual switch "ON", the transmission will start in 2nd gear and shift to 3rd. In 2nd range manual, the transmission starts and stays in 2nd gear, but will up-shift to 3rd gear at 6500 RPM to prevent damage to the engine. In 1st range manual the transmission stays in 1st gear and also will up-shift to second at 6,100 RPM to prevent damage to the engine. Additionally, on 4WD vehicles, the TCU applies a more aggressive 4WD map when the selector is in the 1st position, manual switch "ON" or "OFF". These changes result in improved drive ability on low friction road surfaces.

In 1995 the manual button was deleted. 3 select, shifts 1st, 2nd, and 3rd. 2 select, shifts 1st, 2nd. 1st select, stays in 1st. 1995 through 1998 model year vehicles the TCU controlled up-shift logic was replaced by a fuel cut logic.

The 1993 Impreza was introduced with fuel cut logic, never having an auto up shift logic.

1992 through 1997 SVX used the same shift logic as the 1990 through 1994 Legacy. Retaining the Manual button until production of the vehicle was discontinued in 1997.

GEAR RATIOS

1st	2.785
2nd	1.545
3rd	1.000
4th	0.694
REV	2.272

Final Drive: 3.70:1 or 3.90:1

Legacy Final Drive: 4.11:1 4WD
3.70:1 FWD

7

Refer to Service Manual for specific model gear ratios.



The TCU monitors various engine and vehicle inputs, i.e., throttle position and vehicle speed, etc. It also controls the electronic shift solenoids in the transmission. Refer to the appropriate MY service manual, section 6-3 for the location of the TCU.

4EAT Transmissions

Features

TRANSMISSION FEATURES

- Lock-up Torque Converter
- Variable Displacement Oil Pump
- Double Planetary Gear Set
- Multi-Plate Transfer Clutch (4WD)
- Electronic Control System

9

The 4EAT features a double planetary gear set, a lock-up torque converter, and variable displacement oil pump. The 4WD system includes a Multi-Plate Transfer Clutch (MPT).

The electronic control system is designed to reduce shock during shifting, improve driving performance, and improve fuel economy. A self-diagnostic system is incorporated in order to improve serviceability and reliability.

The electronically controlled Multi-Plate Transfer (MPT) System provides for controlled transfer clutch torque. It is designed to slip in order to eliminate torque bind on cornering.

Shift control cable is a push pull type. Allowing for a compact operating area and quiet operation.

Major Components

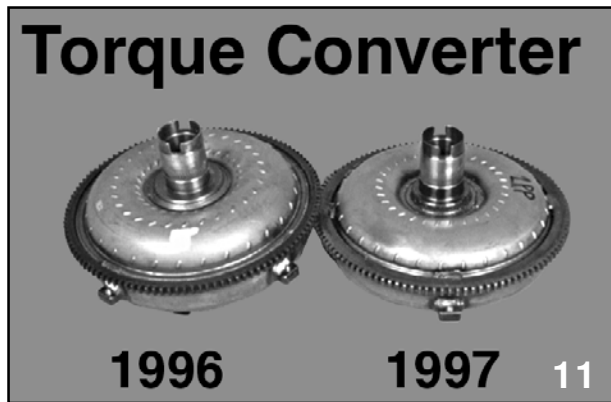

Lock-Up Torque Converter

The torque converter developed for the 4EAT is designed to match a wide range of engines from large to small displacement. It is also designed to improve acceleration from a stop and reduce fuel consumption.



1997 model year turbine shaft was redesigned as a result of a torque converter change. The new shaft has 23 splines' verses 22 splines.

The torque converter has an electronically controlled, hydraulic lock-up clutch system that prevents slip loss during medium to high-speed operation. This system replaces the previous centrifugal lock-up type clutch.

There is a friction surface on the back of the lock-up clutch (piston) which locks against the back of the impeller housing. Clutch engagement shock is minimized in part, because of the torsional clutch dampers and the wave spring/friction washer combination.

4EAT Transmission

LOCK-UP OPERATION

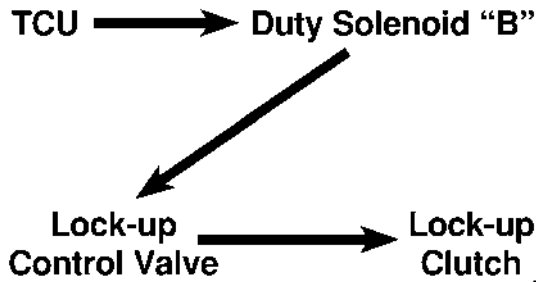

16

The lock-up operation is controlled by the TCU which then regulates Duty Solenoid "B" mounted on the lower valve body. This solenoid provides control of the lock-up valve located in the transmission upper valve body. Finally, the lock-up valve activates the lock-up clutch (piston) located in the torque converter.

Lock Up Operating Modes

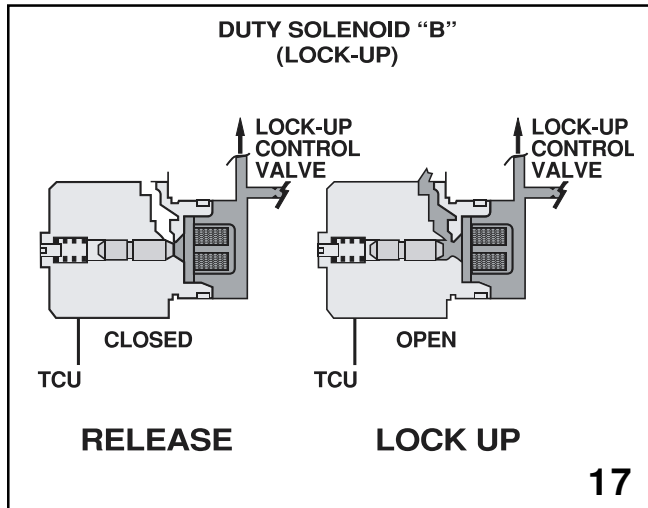

17

The TCU regulates the cycle of Duty Solenoid "B". When the duty solenoid operates at 5% duty, i.e., substantially more "OFF" than "ON", pilot pressure is directed to the lock-up control valve.

When Duty Solenoid "B" operates at 95% duty, i.e., substantially more "ON" than "OFF", it reduces pilot pressure to the control valve.

LOCK-UP CONTROL VALVE

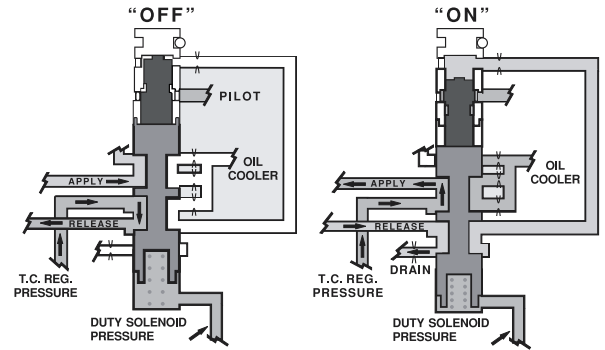

RELEASE

LOCK UP

18

In this condition, the control valve is pushed UPWARD by the combined pilot pressure and spring force. This allows regulated hydraulic pressure to enter the lock-up release circuit.

In this condition, the control valve is pushed DOWNWARD due to the reduced pilot pressure. As a result, regulated hydraulic pressure is directed to the lock-up apply circuit and the release circuit drains.

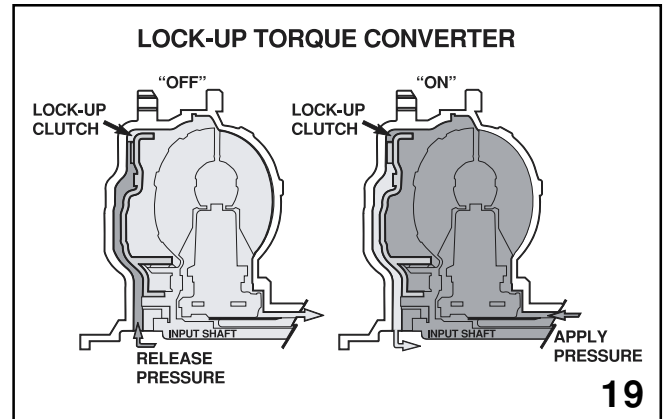

19

The release pressure then pushes the lock-up clutch (piston) rearward and the lock-up clutch is released from the impeller cover. On the other hand, oil drains through the apply circuit to the oil cooler in the radiator.

The apply pressure then pushes the lock-up clutch (piston) forward which engages the lock-up clutch with the impeller cover. When engaged, the transmission is coupled directly to the engine.

4EAT Transmissions

Oil Pump Assembly

A variable rate vane type pump is used for optimum flow rate control with minimum energy loss. In addition to pressurizing the oil, the pump provides lubrication oil for the torque converter, the valves, the clutches, low / reverse brake and the band.

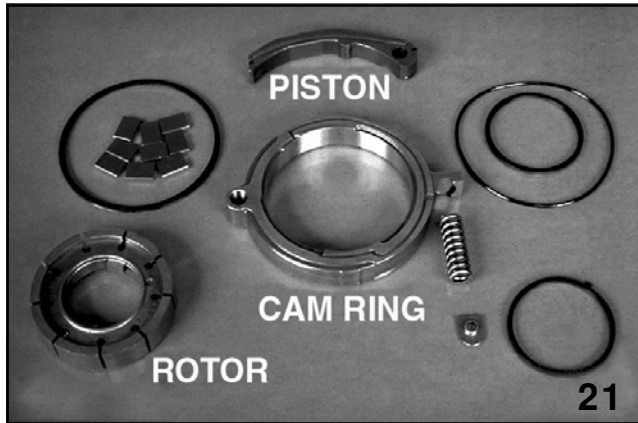

The pump consists of the following components:

1. Rotor
2. Vanes
3. Control Piston
4. Vane Rings
5. Cam Ring
6. Return spring
7. Seal Ring
8. Oil Pump Cover

NOTE: THE ROTOR, VANES, CAM RING AND CONTROL PISTON ARE ALL SELECTIVE.

The pump rate is variable because of the cam ring eccentricity. The eccentricity is adjusted automatically corresponding to pressure from the regulating valve acting upon the control piston.

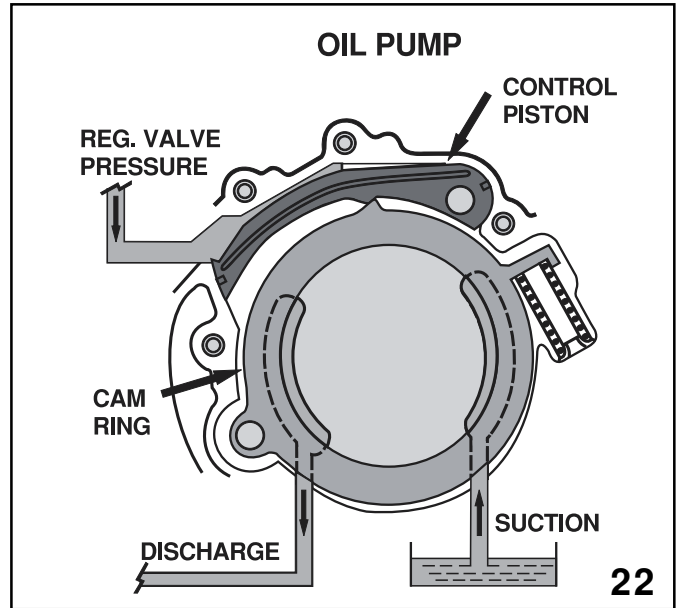

Oil Pump Operation

During low speed operation, filtered ATF is drawn into the pump suction port. The pump is driven directly at engine speed and the ATF is then compressed by the rotor vanes and discharged through the delivery port in the oil pump cover. The pressurized ATF then flows to the rest of the transmission case.

During high-speed operation, as the engine speed increases, the delivery rate normally increases. However, feedback pressure generated from the regulator valve is applied to the control piston, which pushes down the cam ring. This changes the relationship between the cam ring and the rotor. In this way, the pump delivery rate remains at a constant value.

Cases were modified to prevent flexing of the line pressure passage. This condition could cause a gasket failure and reduced line pressure. As a result damage to the high clutch and reverse clutch plates would occur.

4EAT Transmission

Transmission Gear Train

This compact unit features, a double planetary gear set. It has a wide ratio between gears for improved fuel efficiency as well as high performance.

Operating Principles: Rear Gear Set

The input shaft always powers the rear sun gear. The rear planetary carrier (front internal gear) always transmits power to the output shaft.

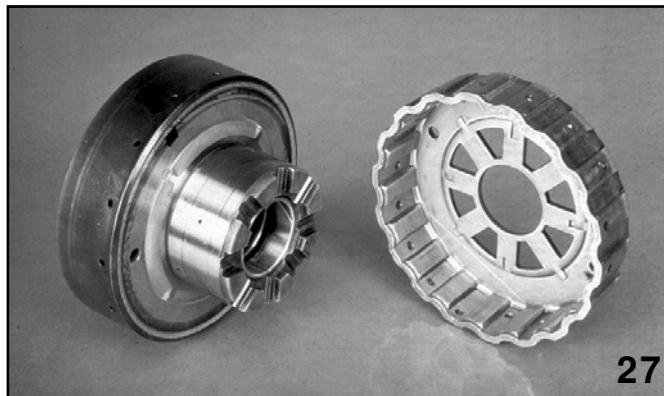
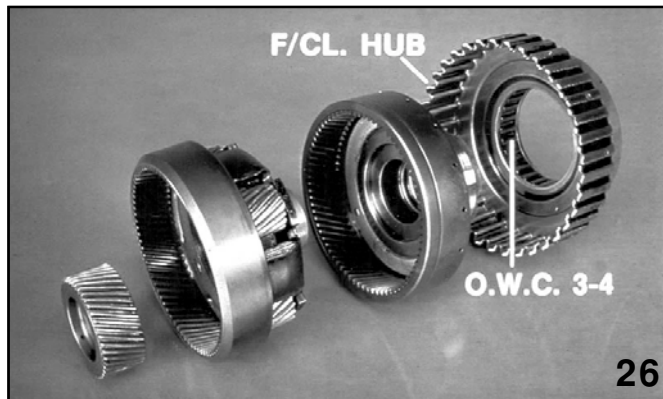

The one way clutch (O.W.C.) 3-4 prevents the rear internal gear from turning counterclockwise. Its inner race is the rear internal gear and its outer race is the forward clutch hub. The overrunning clutch hub is also connected to the rear internal gear by dogs.

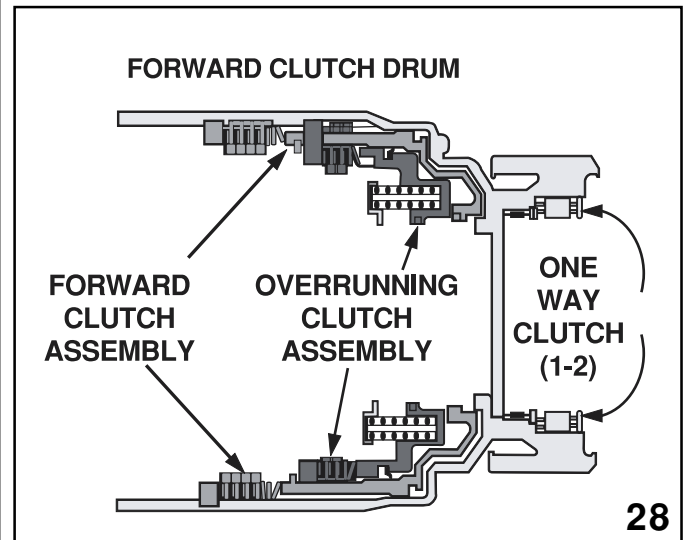

The forward clutch connects the rear internal gear to the front planetary carrier (splined to the forward clutch drum) through the O.W.C. 3-4. The overrunning clutch is also used to connect the rear internal gear to the forward clutch drum and the front planetary carrier.

The O.W.C. 1-2 (Sprague) prevents the forward clutch drum from rotating counterclockwise. The sprague is applied when the transmission is operating in D-1 or 3-1.

The Low/Reverse brake is splined to the case. It holds the forward clutch drum in order to prevent it from turning when the transmission is in Reverse, 2-1, and 1-HOLD.

The overrunning clutch provides engine braking during deceleration except in D-1 and 3-1.

The O.W.C. 3-4 is used in 1st, 2nd, and 3rd gears. The forward clutch is used in all forward gears.

The rear internal gear is controlled by the forward clutch through the O.W.C. 3-4. Additionally, the rear internal gear is controlled by the overrunning clutch. Functioning as an input member in 3rd. Fixed member in 1st and free member in reverse.

4EAT Transmissions

High Clutch and Reverse Clutch

The high clutch drum (reverse clutch hub) is splined to the input shaft. It supplies power to the reverse clutch and the high clutch. The high clutch hub is splined to the front planetary carrier. When the reverse clutch is applied for Reverse gear it powers the front sun gear. When the high clutch is applied in 3rd and 4th gear it powers the front planetary carrier via the high clutch hub.

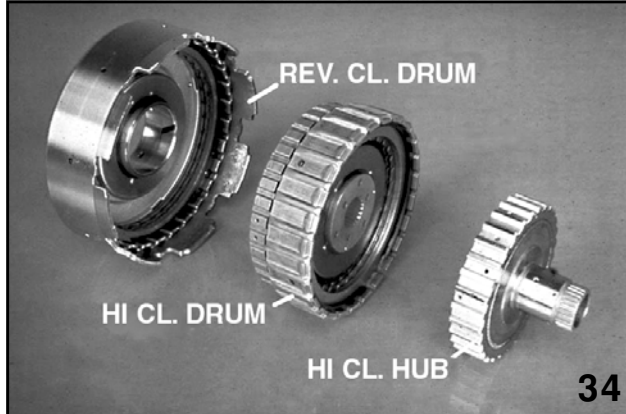

Lubrication holes for the high clutch bearing were changed from the original, with 3 – 1mm holes. The second version had 3 – 1.5mm holes. The third and final version has 6 – 2mm holes.

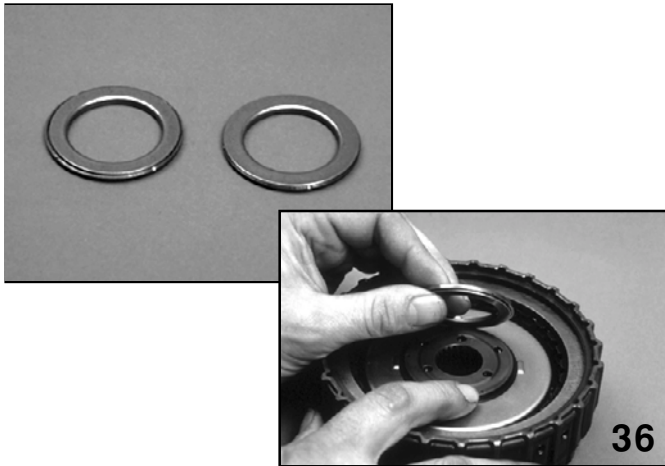

The high clutch bearing race was modified to improve lubrication. Race width was reduced to work better with the enlarged lubrication holes (the bearing on the left pictured above has the modified race) of the high clutch. Bearing position is critical when installed.

Operating Principles: Front Gear Set

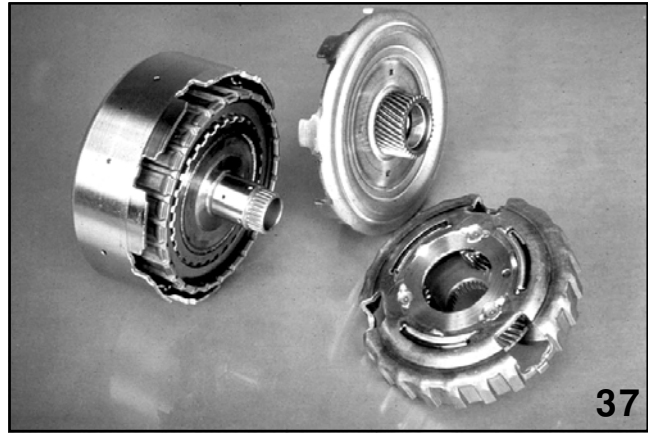

The front sun gear is dogged to the reverse clutch drum. It functions to be the main input member in reverse, never used as an output member. It serves as a fixed member in 2nd & 4th gear. Is a free rotating member in 1st & 3rd gear.

The front planetary carrier is splined externally to the high clutch drum. It functions, as an input member in 3rd & 4th, never used as an output member. It serves as a fixed member in 1st & reverse. And a free rotating member in 2nd.

Band Servo Operation

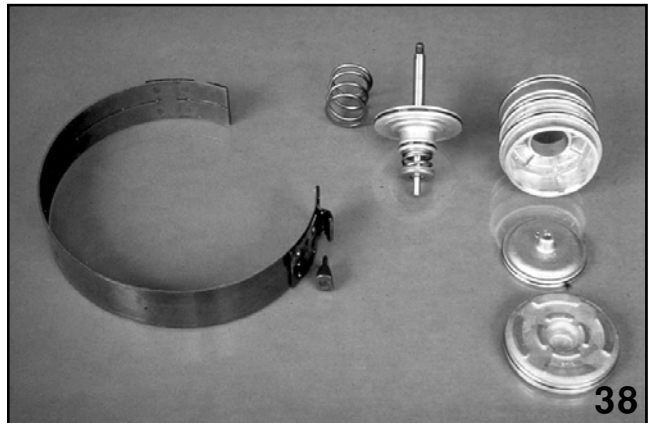

The band is applied in 2nd and 4th gears by a two-stage servo, which is controlled by accumulators.

4EAT Transmission

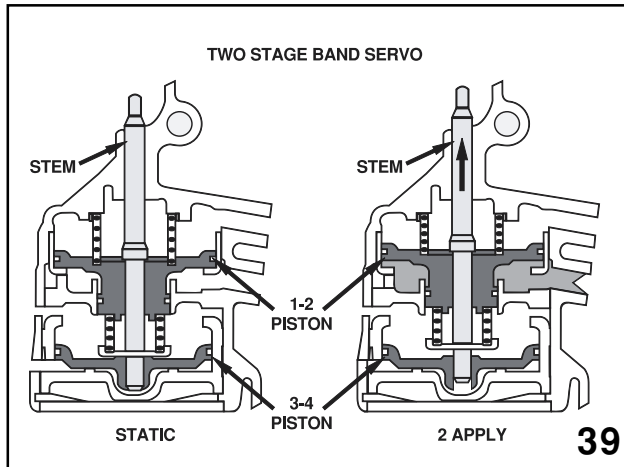

In order to obtain second gear the servo is in the 2-Apply mode. Hydraulic pressure from the 2A accumulator pushes the 1-2 piston UPWARD, which tightens the band.

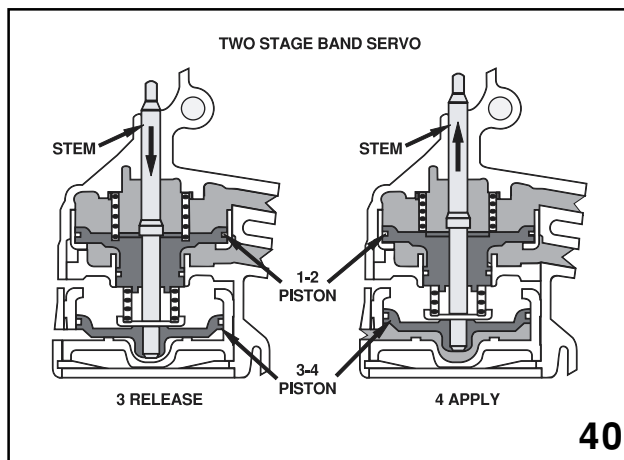

For third gear, the servo is in the 3-Release mode. In this case, hydraulic pressure from the 3R accumulator aided by the return spring pushes the 1-2 piston DOWNWARD in order to release the band.

For fourth gear 4-Apply mode, hydraulic pressure from the 4A accumulator pushes the 3-4 piston UPWARD in order to apply the band.

Operating Principles: AWD

Transfer Clutch Assembly (AWD)

The transfer unit consists of a hydraulic multi-plate clutch and a hydraulic control system incorporating a duty solenoid. It is housed in the extension case at the rear of the transmission. A caged needle bearing supports the clutch on the reduction drive shaft and a ball bearing supports the clutch in the case.

Duty solenoid "C" regulates the MPT clutch. It is controlled by the TCU, which determines the degree of AWD by altering the duty ratio. As the duty ration increases the amount of AWD decreases.

The clutch itself features friction discs that are designed to slip. This eliminates torque binding during tight cornering. In order to get power to the front wheels; the reduction gear powers the reduction driven gear, which is attached to the drive pinion shaft.

AWD component details

For the rear wheels, power goes from the reduction drive shaft to the MPT clutch hub, which is welded to the drive gear. The power is transferred through the MPT clutch where it outputs to the rear drive shaft.

Reduction shaft seal rings direct fluid from the hollow shaft to the lubrication circuits inside the transmission.

Beginning in the 1990 model year a new transfer piston was added. This improved torque split control, preventing the MPT clutch from further applying during high speed driving. Cancels centrifugal pressure buildup affect, behind the clutch apply piston.

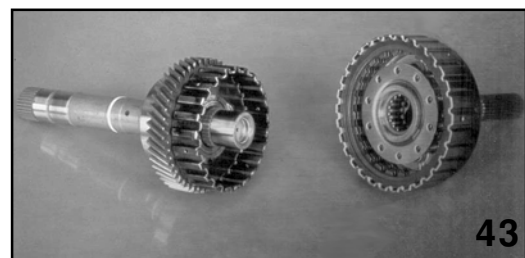

Transfer clutch hub is welded to the reduction drive gear. Bringing power into the MPT clutch assembly.

The reduction shaft seal rings direct fluid from the hollow shaft to the lubrication circuits inside the transaxle.

4EAT Transmissions

The plug on the end of the shaft has a small hole for maintaining lubrication pressure and directing lubrication oil to the clutch drum caged needle bearing.

The transfer clutch drive and driven plates are sold as a set. The plates are "broken in" as part of the manufacturing process. It is necessary to keep in specific order they are packed when installing them into the old drum. Also to order the correct set you must measure the existing clutch pack clearance selective plate.

Final Drive

The hypoid gear set is mounted in the aluminum torque converter case. Supported by tapered roller bearings. Differential carrier housing has removable stub axle shafts. The pinion is mounted through the oil pump housing.

Oil Pump Housing Features

The housing is made of cast iron for greater rigidity. Double taper roller bearings are used to support the pinion. This allows for the thermal expansion of two dissimilar metals: aluminum and cast iron. These bearings also improve the durability and reliability of the unit. The bearings are preloaded by a locknut, which allows for easy serviceability.

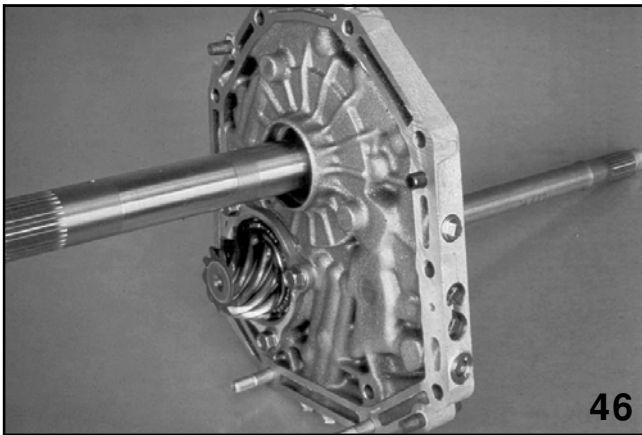

Pinion depth is set by shims, which are located between the bearing flange and the oil pump housing.

A double-lip oil seal separates transmission fluid from the hypoid gear oil. This greatly improves the fluid system reliability.

Differential Carrier Features

The ring gear is mounted on the right side of the carrier. This design adds to its compactness and makes it easier to service. The backlash is easily adjustable through the carrier bearing retainers.

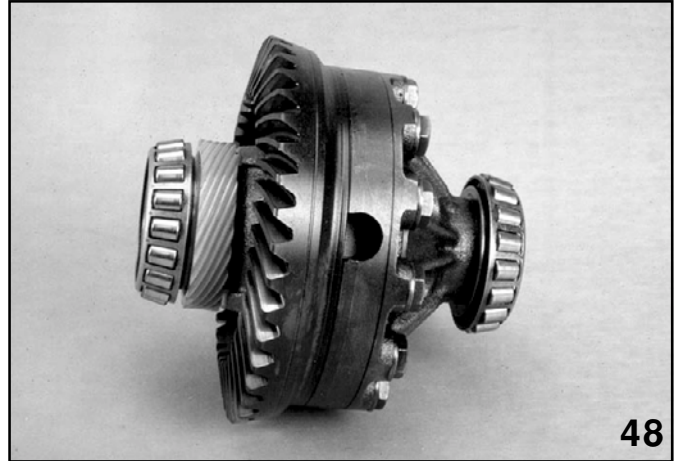

Hydraulic Control System

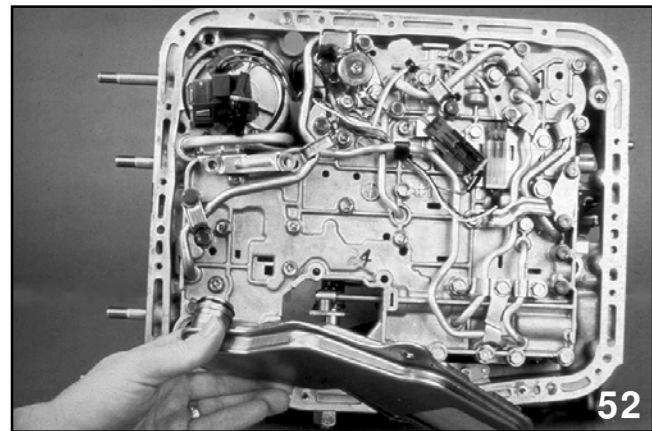

4EAT Transmission

Valve Body

The valves and solenoids control the lubrication circuits, the lock-up torque converter, shifting, etc.

The valve body is divided into two major sections: upper and lower.

The valve body works in conjunction with the TCU. It is designed to provide smooth shift control and component longevity. It also reduces unnecessary high pressure in certain instances. As an example, line pressure is lowered between shifts.

The valve body features shift step control. This means that gear members are momentarily applied between shifts it allows them to be brought up to speed, which reduces shock.

Accumulators

There are four accumulators mounted in the transmission case:

- 4-Apply (4A)
- 2-Apply (2A)
- 3-Release (3R)
- Neutral/Drive (ND)

They are designed to lessen shift shock by absorbing the sudden pressure change generated when a circuit is activated. This ensures smooth component application. The accumulator resistance will vary in direct proportion to the line pressure.

Accumulator Operation

Accumulators normally operate at a fixed rate in other automatic transmissions. Therefore, as the transmission pressure rise, the accumulator cannot further compensate due to the constant value of the spring. Pressure shocks are thus transferred to the components.

In the 4EAT Accumulators, however, the line pressure is applied to the back of the accumulator piston. Therefore, the resistance to pressure is proportionally increased hydraulically. This keeps the pressure shock under control, allowing smoother component application.

An additional accumulator is located in the lower section of the valve body, next to the manual valve. It absorbs line pressure pulses created by the sudden changes in the pressure.

Component Disassembly / Inspection

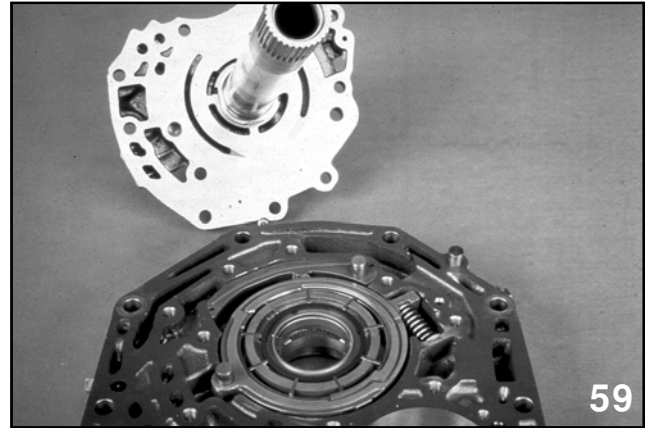

In order to inspect the oil pump assembly, remove the pump cover and then lift out the pump components. Examine the piston and cam ring seal. Check the rotor, piston, vanes, and cam ring for cuts, gouges, etc. Replace any components that show evidence of excessive wear or damage.

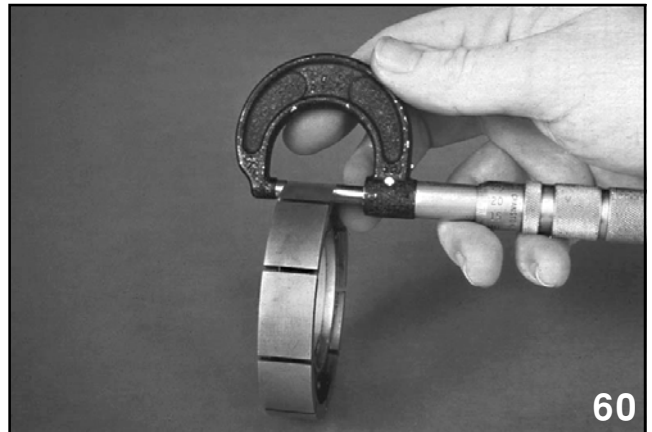

Measure the pump components in at least four positions in order to maintain correct component to housing clearance.

4EAT Transmissions

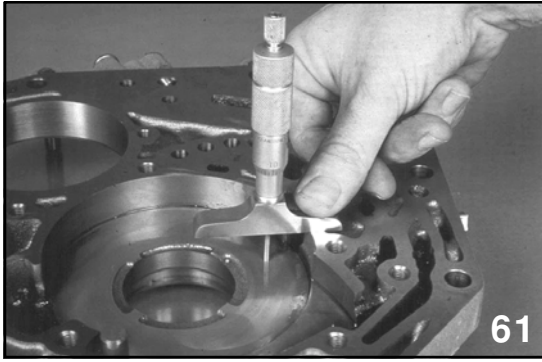

Measure the oil pump housing depth in several places. Then subtract the readings from the previous measurements. Finally, check the wear limits in order to determine the proper clearance when installing new components. Select vanes, which are the same height as the rotor.

NOTE: SHOULD THE ROTOR OR VANES REQUIRE REPLACEMENT, BE SURE THEY ARE BOTH THE SAME HEIGHT.

NOTE: REINSTALL LIBERALLY LUBRICATED COMPONENTS. THE DOUBLE LIP SEAL AND RETAINER WILL BE INSTALLED LATER.

Drive Pinion

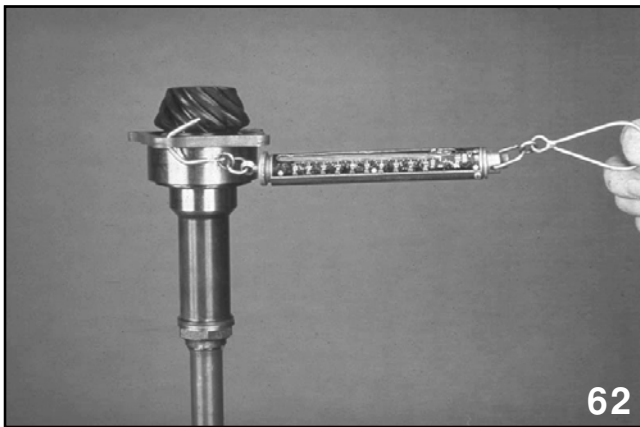

Prior to disassembling the pinion shaft, verify proper starting torque of the bearings.

IF THE REPAIR IS FOR OTHER THAN A RING AND PINION LUBRICATION FAILURE THIS SHOULD BE DONE FIRST. SO A NEW BEARING CAN BE ORDERED PRIOR TO REASSEMBLY IF OUT OF SPECIFICATIONS. IF THERE IS A RING AND PINION LUBRICATION FAILURE, YOU WILL MORE THAN LIKELY NEED A NEW BEARING.

IF THE BEARING IS OUT OF SPECIFICATIONS, NEW ROLLER BEARINGS ARE REQUIRED. DO NOT OVERTIGHTEN THE LOCK NOT TO COMPENSATE.

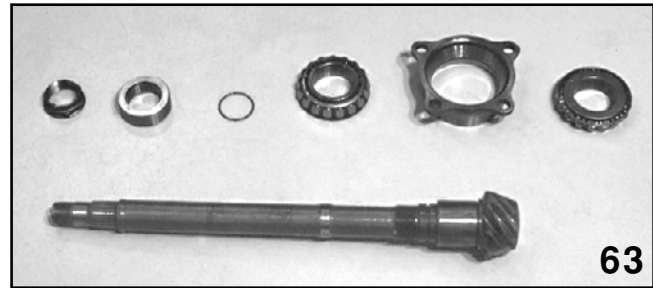

Disassemble the drive pinion shaft and examine the components for gouges, cuts, damage, etc.

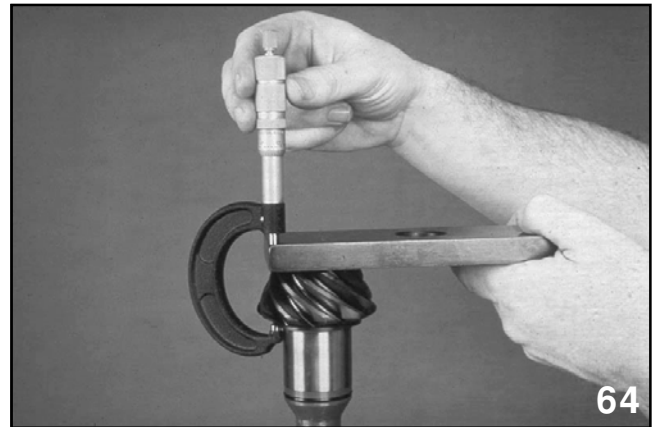

Next, determine the pinion depth. A two step process is used to determine the number of shims and the thickness of the shims.

First, measure the thickness of the pinion gear and record this as measurement "A".

NOTE: DIMENSION "A" INCLUDES THE THICKNESS OF THE TOOL.

Then install the flange assembly with bearings using a new O-ring and carefully install the collar and washer with a new nut. Make sure the bearings are lubricated and then torque the nut to specifications. Use special tools **#499787100** Wrench and **#498937100** Holder. Be sure to stake the new lock nut in place.

4EAT Transmission

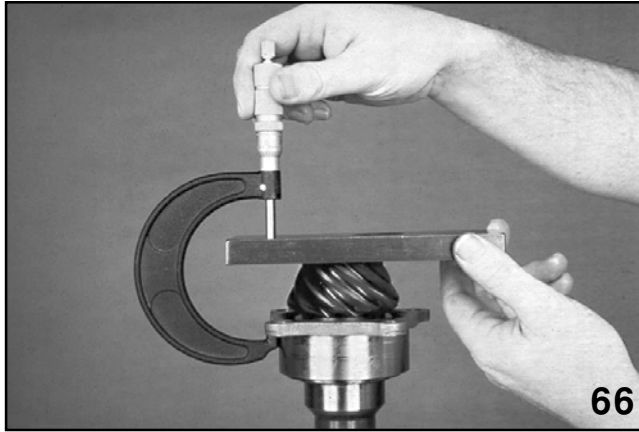

For the second step of the pinion depth measurement, the combined thickness of the flange and pinion must be determined. Record this as measurement "B".

Perform the following calculation in order to determine the shim thickness (t) in millimeters.

FORMULA: $t = 6.50 \pm 0.0125 - (B - A)$

- t = Thickness of drive pinion shim(s)
- 6.50 ± 0.0125 = Ideal distance of pinion protrusion from oil pump housing
- B = Thickness of pinion and flange
- A = Thickness of pinion

Finally, mount the pinion to the housing using the selected shim(s).

NOTE: NO MORE THAN 3 SHIMS MAY BE USED. REFER TO SECTION 3-2, [W8C8], SUBARU SERVICE MANUAL TO DETERMINE THE PROPER SHIM SELECTION.

Reassembly

Inspect the clutches for damage caused by normal wear, heat, contamination, or component failure.

Also examine the sealing ring and the lip seals for damage, and see that the check balls aren't sticking.

Clutch Reassembly Precautions

- Orient the dish plates correctly.
- Lubricate the components liberally with ATF and allow time to soak.
- Measure the clutch pack clearance between the retaining plate and the snap ring.
- All retaining plates are selective. See the service manual sec. 3-2, pg. 83.
- Verify their operation with air pressure.

Examine the band friction surface for wear or damage and carefully check the servo and accumulator sealing rings. Note that many different sizes are used. Do not confuse the locations of the components or seals. Also check the bores for scoring damage. Lubricate the components liberally with ATF during reassembly.

Inspect the differential carrier components for wear, cuts or damage. Then reassemble the ring gear to the carrier.

Differential Pinion Backlash

In order to verify the carrier backlash, temporarily, install the stub axle backwards and set up a dial indicator against the side gear. Then lock the pinions with a screwdriver and rotate the axle shaft. Verify the backlash reading. Correct the backlash if it is not within specifications. To change the backlash, disassemble the carrier and change the selective thrust washer(s) located behind each side gear.

Transfer Clutch Valve Assembly

In the transfer case, inspect and clean the valve body assembly. This includes the transfer clutch valve and the pilot valve. Also examine the strainer located in the case. Clean as necessary.

Transmission Reassembly

NOTE: EACH AND EVERY REASSEMBLY STEP IS NOT BEING COVERED IN THIS BOOKLET. THEY ARE COVERED IN THE SERVICE MANUAL. ONLY THE KEY REASSEMBLY STEPS/MEASUREMENTS WILL BE COVERED IN THIS PORTION OF THE BOOKLET.

Torque Converter Case

Install the differential carrier into the case being careful of the nylon speedo gears. Then insert the stub axle shafts using new snap rings and check the axle shaft thrust play.

Next, wrap the stub axles with vinyl tape and install the carrier bearing retainers. Screw in the right retainer further than the left retainer. This prevents potential damage to the ring and pinion.

Final Drive Pre-load & Backlash

Install the oil pump housing using four bolts. Take extra precaution to protect the sealing surface from bolt damage by temporarily installing gasket material under the bolt heads.

4EAT Transmissions

NOTE: THE LIP SEAL RETAINER CAN BE INSTALLED BEFORE OR AFTER PERFORMING THE BACKLASH ADJUSTMENT. CHECK THE ORIENTATION OF THE LIP SEALS AND USE THE SPECIAL TOOL #4992457300 TO INSTALL IT AT THE CORRECT DEPTH.

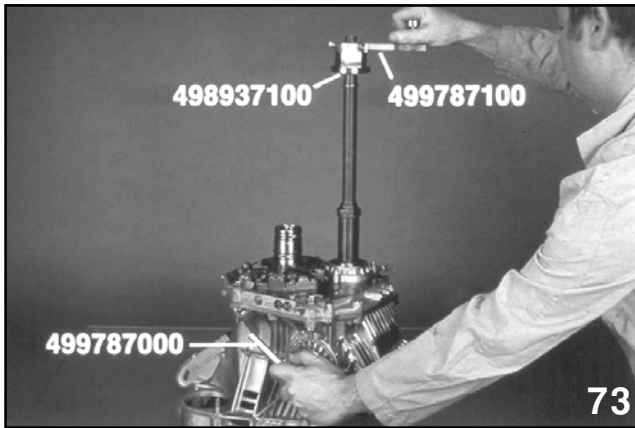

Next, rotate the pinion several times using the following special tools:

- #499787100 Wrench
- #498937100 Holder

In order to set the pre-load, the “zero” state must be established first. Tighten the LH retainer and loosen the RH retainer until contact is felt while rotating the shaft. Repeat this process several times to confirm the point at which the contact is felt. This is the “zero” state.

After the “zero” state is established, back off the LH retainer 3 notches and secure it with the locking tab. Then back off the RH retainer and retighten until it stops. Repeat this procedure several times. Tighten the RH retainer 1 3/4 notches further. This sets the pre-load. Finally, secure the retainer with its locking tab.



In order to check the backlash; mount a dial indicator securely so that it extends through the drain hole. Then lock the pinion shaft using the special tool #499787100 (Wrench), and check the backlash.

In order to change the backlash; rotate the retainers an equal amount in opposite directions. This maintains the proper pre-load. In order to increase backlash, loosen the LH retainer and tighten the RH retainer. In order to decrease backlash, tighten the LH retainer and loosen the RH retainer. One notch of the retainer equals 0.002 in. or (0.05mm).

Finally, mark the position of the retainers, and remove them so they can be reinstalled with their O-rings. Also reinstall and secure the lock-plates.

Forward Clutch Installation

NOTE: THE LOW/REV BRAKE HAS ALREADY BEEN INSTALLED.

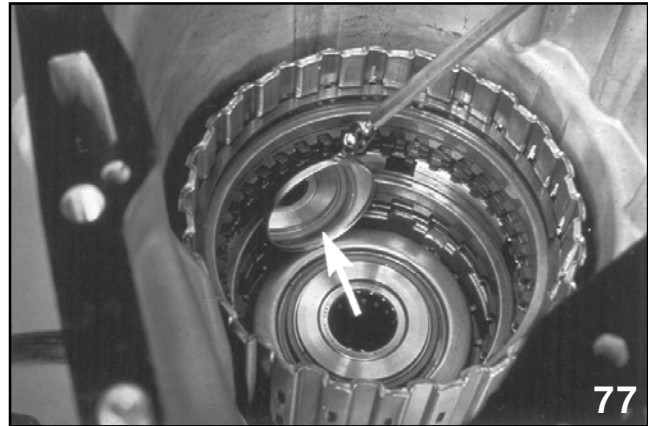

Install the forward clutch drum into the low/rev brake. Rotate the drum carefully during installation. It can only rotate clockwise due to the O.W.C. 1-2.

In order to verify a proper installation; check the relationship between the drum and the O.W.C. 1-2 inner race. The race should protrude slightly.

4EAT Transmission

Reverse Clutch Drum End-Play

NOTE: THE BALANCE OF THE GEAR TRAIN COMPONENTS HAS ALREADY BEEN INSTALLED.

Select a washer for proper end-play adjustment using the following formula.

FORMULA (mm):

- $t = (M + 0.40) - m - (0.55 \text{ to } 0.90)$
- t = thickness of thrust washer (to be determined)
- M = Distance from top of case to reverse clutch drum
- 0.40 = Thickness of gasket
- m = Distance from reverse clutch thrust surface (on oil pump cover) to oil pump housing
- 0.55 to 0.90 = Ideal reverse clutch end-play

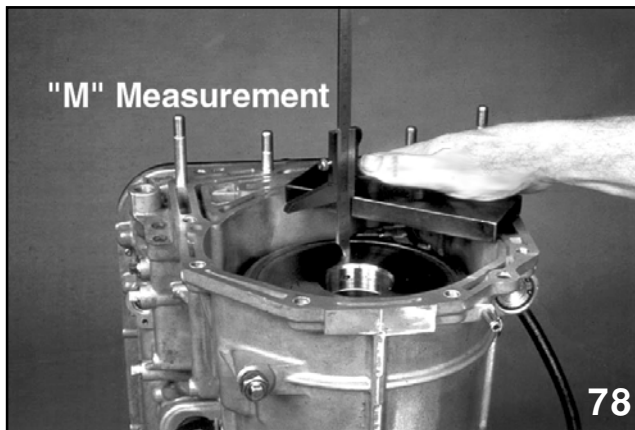

First measure "M" using a depth gauge noting that no gasket is used. Measure where the thrust washer contacts the drum and record the reading.

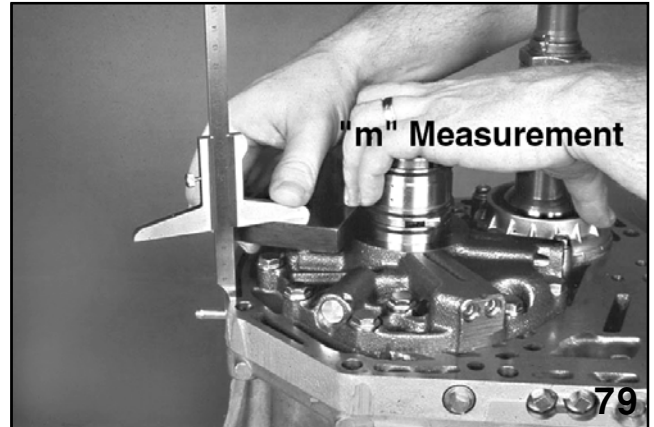

Then measure "m" using the same measuring block and depth gauge. Finally, perform the calculations to determine "t" (large washer). Choose the proper thrust washer as listed in the service manual, sec. 3-2, [W4B2]. Subaru Service Manual to determine the correct thrust washer.

Total End-Play

Select a washer for total endplay using the following formula:

FORMULA (mm):

- $T = (L + 0.40) - l - (0.25 \text{ to } 0.55)$
- T = Thickness of race
- L = Distance from case to reverse clutch drum race surface
- 0.40 = Thickness of gasket
- l = Distance from top of oil pump cover needle bearing to oil pump housing
- 0.25 to 0.55 = Ideal total end-play

First measure "L" using a depth gauge. Again, note that there is no gasket. Measure to the race surface and record the reading.

4EAT Transmissions

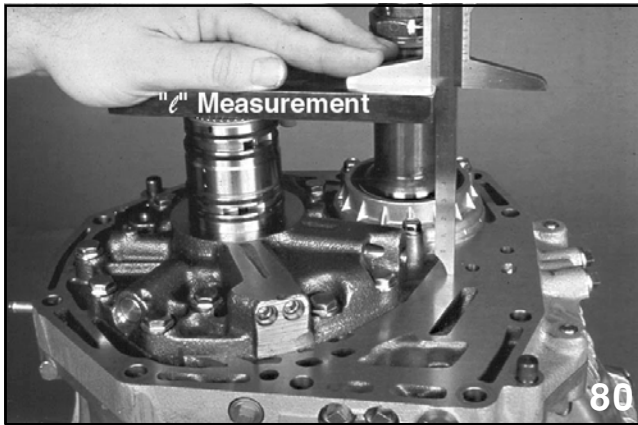

Next, measure “l” using the same measuring block. With the bearing in place, record the reading. Perform the calculations to select “T” (small 3 tanged washer). Refer to sec. 3-2, [W4B2] Subaru Service Manual to determine the correct thrust washer.

Valve Body Precautions

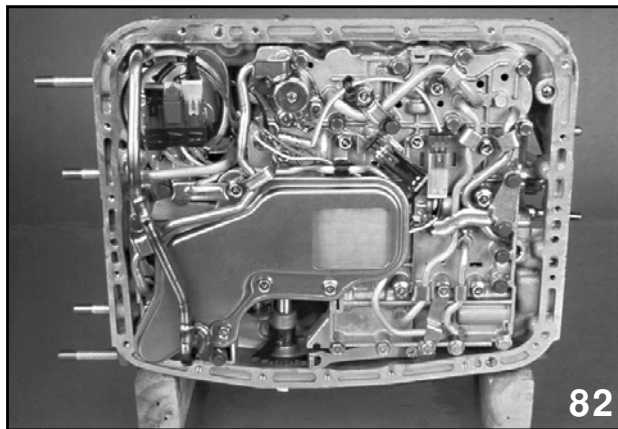

- Route the harness correctly.
- Torque the mounting bolts evenly.
- Use a new O-ring on the strainer.
- Install the oil cooler pipe.
- Make sure the magnet is properly positioned on the pan.
- Torque the pan bolts evenly.

Extension Case

In order to determine the endplay measurement (4WD), measure the distance from the extension case gasket surface to the transfer clutch thrust surface (4WD) using the formula below.

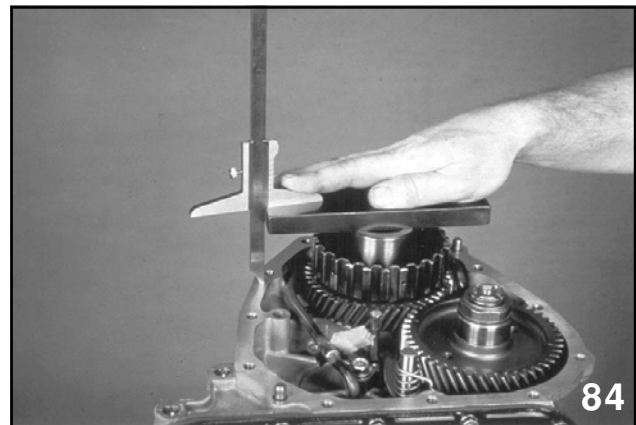
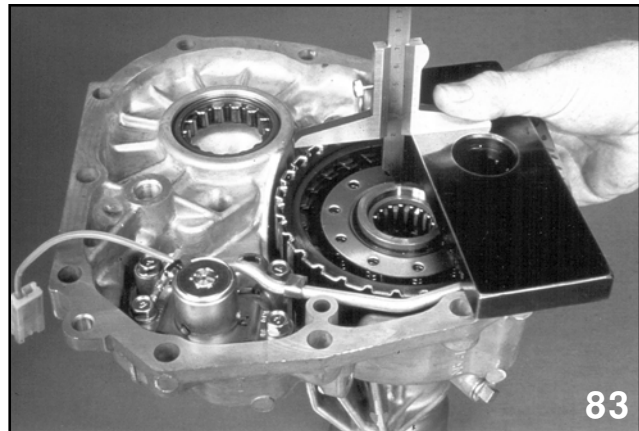

NOTE: HEIGHT OF GAUGE TOOL #499577000 MUST BE SUBTRACTED FROM L.

4EAT Transmission

FORMULA (mm):

- $T = (L + 0.40) - \ell - (0.05 \text{ to } 0.25)$
- T = Thickness of thrust bearing
- L = Distance from extension case gasket surface to transfer clutch thrust surface
- 0.40 = Gasket thickness
- ℓ = Distance from transmission case gasket surface to reduction drive gear thrust surface
- 0.05 to 0.25 = Ideal end-play

Select the proper bearing/washer from the chart in sec. 3-2, [W4B6] pg. 78 Vol. 2 of the 1995 service manual.

In order to determine the endplay measurement for FWD vehicles, use the same procedure as 4WD except:

- T = **Thickness of thrust washer**
- L = Distance from rear cover to reduction drive shaft bearing mounting surface
- ℓ = Distance from transmission case to bearing surface

Transmission Reinstallation

Reverse the order of removal except for the following procedures:

1. Torque the rear cross member bolts to specification.
2. Use new axle spring pins, making sure the chamfered DOJ and stub axle holes align.
3. Torque the transverse link bolts noting that the vehicle must be on the ground.
4. Install the gearshift cable and verify proper gearshift operation.
5. Install the pitching stopper by tightening the body side bolt first.
6. Add differential fluid and ATF.
7. Road test the vehicle.
8. Re-check the fluids for the proper level or leaks.

Whenever performing any service work on the 4EAT Transmission **ALWAYS** use the appropriate Subaru Service Manual.

Electronic Control System

Overview

The electronic control system consists of various inputs (sensors) and outputs (lights and solenoids) in addition to the Transmission Control Unit (TCU).

This is the second generation of Subaru automatic transmission. In addition to being smoother and quieter, it is designed to help maximize fuel economy while providing performance.

It monitors the engine and transmission performance conditions, the driver's demands and the vehicle speed.

Transmission Control Unit

The TCU is a highly sophisticated microprocessor with a self-diagnostic long-term memory. It also has a fail-safe function, which maintains driveability in case of a major electrical component failure.

In a transmission equipped for 4WD the TCU utilizes a program which continually changes the degree of 4WD based upon vehicle operating condition(s).

The TCU controls shifting and line pressure in addition to the lock-up torque converter and the MPT clutch.

TCU Inputs

- Throttle sensor/idle switch
- Vehicle speed sensor #1
- Vehicle speed sensor #2
- Tachometer signal
- Inhibitor switch
- Cruise control signal
- ATF temperature sensor
- Ignition/battery voltage
- 1-HOLD switch
- Forced FWD

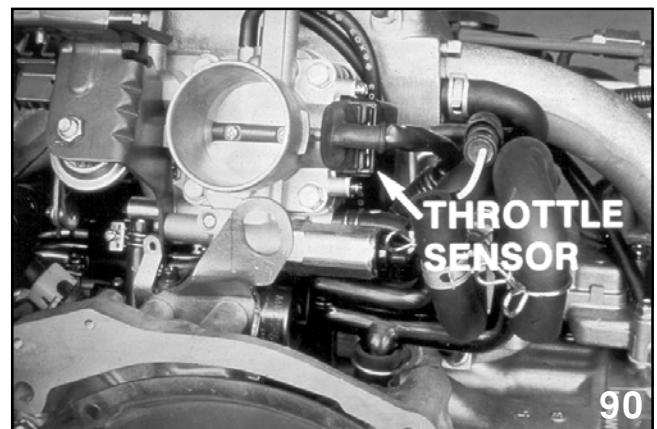

4EAT Transmissions

The throttle sensor/idle switch is basically electrical throttle pressure. The load signal effects: shifting, line pressure and lock-up. The closed throttle input effects the lock-up release mode as well as smooth downshifting into 2nd gear. It also causes a reduction in the pressure.

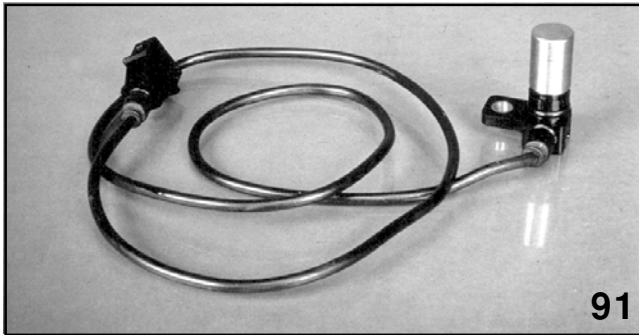

Vehicle speed sensor #1 is mounted to the transmission and is basically electrical governor pressure. It is used to detect vehicle speed and it effects shift points, lock-up, and line pressure.

In FWD transmissions, the speed sensor reads parking gear rotation at the front output shaft. In 4WD transmissions, it senses the transfer clutch drum rotation at the rear output shaft.

Vehicle speed sensor #2 is built into the combination meter. In FWD units, it is used as a back up for speed sensor #1. In 4WD units, it is used as the front output shaft speed sensor.

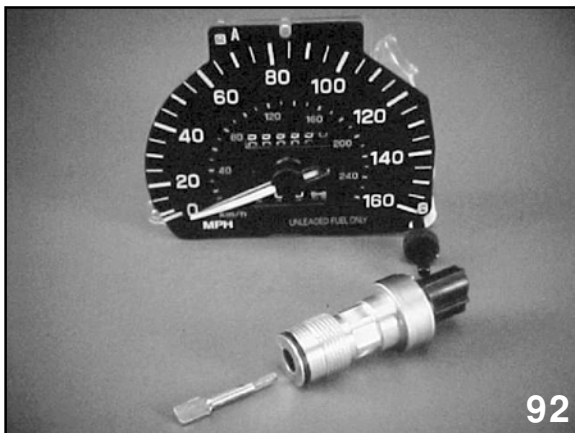

Starting with SVX introduction in 1992, then added to 1995 Legacy, 1996 Impreza, 1998 Forester an electric speedometer system was introduced. The system uses a Magnetic Resistance Effect (MRE) type speed sensor driven by a conventional speedometer drive gear system. The speed sensor, which generates four pulses per revolution, is located on the front differential housing.

The Speedometer Driving Unit (SDU) receiving pulses from the MRE sensor processes the signal sending the information to the transmission control unit.

The TCU compares the speed signal from the front output shaft with the signal from the rear output shaft (sensor #1). The speed differential helps the TCU determine the degree of 4WD (along with other inputs).

The tachometer signal effects the shift points at kick-down. The TCU uses the signal to prevent the engine from over-revving.

NOTE: THE TCU WILL OVERRIDE THE INHIBITOR SWITCH, IF NECESSARY, IN ORDER TO PREVENT THE ENGINE FROM OVER-REVING.

The cruise control signal tells the TCU of cruise control activation. This allows for a wider operating range in 4th gear unless a large speed differential exists from the set speed in which case the transmission may downshift. This improves fuel economy.



The ATF temperature sensor is located on the lower valve body next to duty solenoid "B". When the ATF is cold, the TCU won't allow an up-shift into 4th gear. The object is to warm the engine quickly for lower emissions. It is more sophisticated than the KDLH system and less objectionable for the consumer.

When the ATF is hot (4WD only), the TCU shifts the transmission as if in the POWER mode. This pushes the shift points higher which allows the engine to run faster. The oil pump then circulates ATF through the oil cooler more quickly so as not to overheat the engine coolant.

The TCU also monitors system voltage in order to correctly interpret the inputs and alter the control of the outputs. For example, the system is designed for 12-volt operation. When running, however, most vehicles have other than 12 volts available.

4EAT Transmission

The 1-HOLD switch is located aft of the shift quadrant. When activated, it creates a forced 1st gear.

NOTE: THE TCU WILL SHIFT 2ND TO 3RD IF NECESSARY, IN ORDER TO PREVENT THE ENGINE FROM OVER-REVVING.

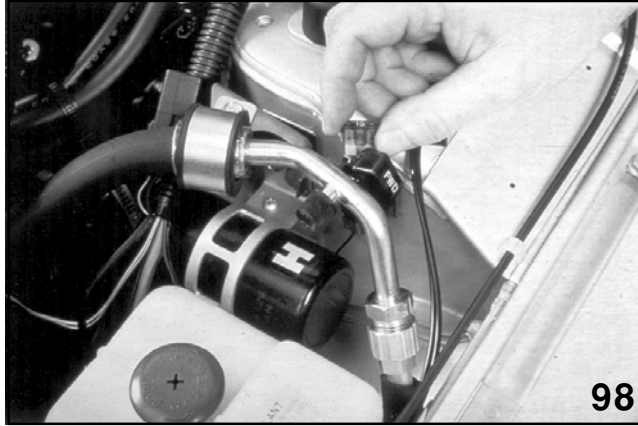

The FWD switch changes the driving mode from 4WD to FWD. The FWD switch is located on the left front shock tower. It is activated by inserting the spare fuse into the under hood connector. The FWD light on the combination meter verifies that the vehicle is in FWD.

Legacy FWD switch is located on the right strut tower. SVX and Forester switch is located in the main fuse box.

Legacy TCU Inputs

The Legacy fuel system ECM, beginning with MY 1990, sends new inputs to the TCU for line pressure control.

It networks the MPFI ECU RPM signal and altitude compensation inputs. This provides additional line pressure control for high altitude compensation to reduce shift shock. ABS system inputs turn "OFF" the over-running clutch when ABS is active and fixes the duty ratio of the MPT to mostly FWD.

Maintenance Precautions

Before jacking up one or two wheels for maintenance with the engine running or before running the vehicle on a chassis dynamometer, the electronic 4WD engagement system MUST be disengaged by installing the spare fuse (15A) of the fuse box into the FWD connector located under the hood. Failure to do so could result in movement of vehicle. (Refer to owner's manual)

TCU Outputs

There are two types of outputs, solenoid controls and light controls. The solenoids control shifting, line pressure, lock-up and 4WD.

The light controls indicate operating conditions to the driver. They indicate the POWER mode, manually selected 1st or 2nd gear, or hot ATF (4WD only).

On the 1990 M.Y. and later Legacy the light controls indicate hot ATF (FWD and 4WD), gears 3 - 2 - 1, MANUAL mode, and POWER mode.

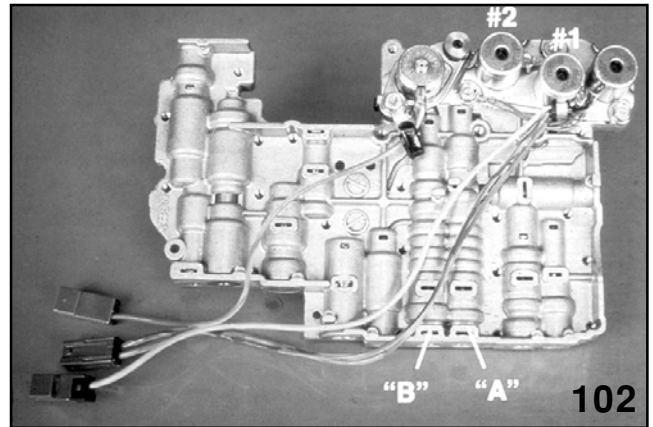

Shift solenoids #1 and #2 are located on the upper valve body. The TCU induces "ON/OFF" conditions, which regulate the shifting of the forward gears.

When a shift solenoid is "ON", it passes pilot pressure to shift valve "A" and/or shift valve "B". The valve(s) will then shift, feeding the appropriate controlling member circuits (high clutch, band, etc.).

NOTE: PILOT PRESSURE IS NOTHING MORE THAN A PRESSURE HELD AT A CONSTANT VALUE.

When a shift solenoid is "OFF", the affected shift valve will move to its static position due to spring pressure. The appropriate controlling member circuit will then be fed (high clutch, band, etc.).

COMPONENT APPLICATION										
	REV./C	B/B	HIGH/C	FWD./C	OWC (3-4)	OVR./C	Lo/REV./B	OWC (1-2)	Sol 1	Sol 2
P/N									X	X
R	●				○		●		X	X
D	1st			●	●			●	●	●
	2nd		●		●				X	
	3rd			●	●				X	X
	4th		●	●	●					X

103

4EAT Transmissions

Shift Modes

Shift solenoid #3 is located on the upper valve body. It is used to control downshifts. It quickly releases the 3-Release pressure during low speed, heavy load situation in order to provide smooth 3-2 downshifts. It operates the overrunning clutch in order to provide engine braking during deceleration. It is also used to cancel the overrunning clutch momentarily during light throttle 3-2 downshifts, or closed throttle 2-1 downshifts. This reduces the shift shock.

Duty Solenoid "A" is located on the upper valve body. It regulates line pressure at 3 levels:

- Basic:
 - Altered with load, vehicle speed, and range signal.
- Shifting:
 - Lower line pressure in between shifts to minimize shift shock.
- Start up:
 - With low ATF temperature or a low tachometer signal [cranking speed], it sets line pressure to a minimum.

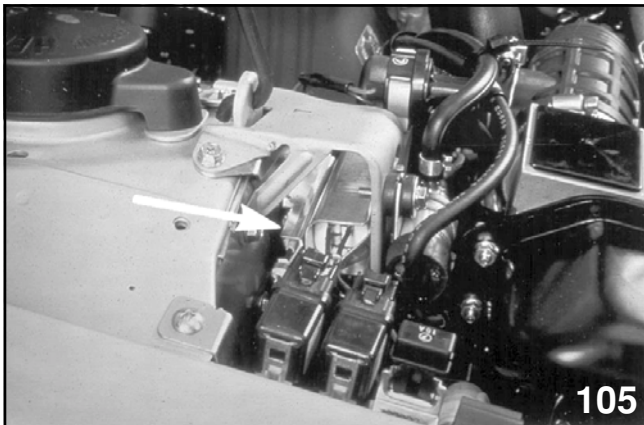

The dropping resistor is wired in parallel with duty solenoid "A", and is used to regulate line pressure. It is located on the right front shock tower behind the MPI fuel system-dropping resistor. It takes over line pressure control during the "OFF" portion of the duty cycle for the duty solenoid. In other words, the duty solenoid is never fully "OFF".

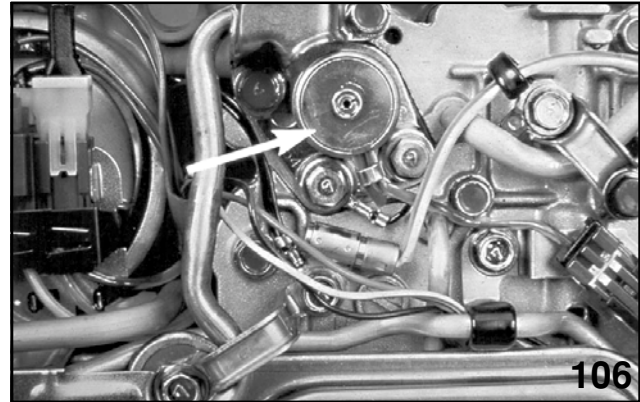

Duty Solenoid "B" is located on the lower valve body next to the ATF temperature sensor. It operates the lock-up clutch in 3 modes: "ON", "OFF", and a gradual "ON/OFF" control of the lock-up clutch during gear shifting in order to reduce shift shock.

Duty Solenoid "C" is located in the extension housing. It is also controlled by the TCU. It varies the degree of 4WD.

Combination Meter Light Operation XT - 6 and L – Series

XT - 6 and L – Series 2nd gear indicator bar is located in the combination meter shift position indicator. Controlled by the TCU, other quadrant indicators are controlled by the inhibitor switch, both providing a path to ground. 2nd indicator bar is affected by the 1 – Hold switch input. With the 1 – Hold button switched "OFF" & the shift selector in the "2nd select" position, the TCU grounds the 2nd indicator light circuit illuminating the 2nd gear indicator.

The 1-HOLD indicator light ("L" and XT only) is located near the shift position indicator. It is activated by the TCU whenever the 1-HOLD button is depressed with the shift lever in "2". It changes the display and cancels the "2" indicator.

The vehicle stays in 1-HOLD unless the TCU determines a potential engine over-rev condition, at which point, the transmission will then up-shift.

NOTE: WHEN 1-HOLD IS ACTIVATED, ALL OTHER SHIFTING INPUTS ARE IGNORED.

ATF temperature warning light was used on AWD vehicles only indicates overheated ATF. See description of TCU inputs for control unit logic in response of hot ATF.

The Power indicator was a frame that illuminates around the word "POWER" on the combination meter. Activation logic of the power mode is the same as later models.

4EAT Transmission

Late Model Combination Meter

Legacy, SVX, Impreza & Forester Lighting

Manual light was activated when the manual button is depressed. On 90 – 91 M.Y. the 3 – 2 – 1 Light box changed color from green to yellow. This feature was discontinued in the 1992 M.Y.

The Manual Light and Switch was discontinued in all models but the SVX in 1995.

The POWER light is activated momentarily whenever the vehicle is started. The computer, monitoring how quickly the gas pedal is depressed selects the POWER mode. This changes the performance characteristics of the transmission. I.E., it delays up-shifts and may downshift if necessary. When selected, the computer turns the POWER light “ON”. The POWER light was eliminated on Legacy beginning with 1995 model year but TCU logic is the same.

NOTE: THERE ARE A NUMBER OF PREDETERMINED RATES BASED ON VEHICLE SPEED VS. THROTTLE ANGLE REALTIONSHIP. THESE DETERMINE EASE OF ACCESS TO THE POWER MODE. AS A GENERAL RULE, IT IS EASIER TO ACTIVATE POWER MODE AT LOWER SPEEDS FROM A LIGHT THROTTLE THAN IT IS AT HIGHER SPEEDS FROM A LIGHT THROTTLE.

Power Pattern Mode increases up and down shift points. It is deactivated by vehicle speed and throttle angle. For example, if speed is equal to or greater than (approximately) 40 MPH with a light throttle deactivation is immediate. Verses, if the speed is less than (approximately) 40 MPH a time lag up to 3 seconds will occur before resuming normal shift pattern.

ATF temperature warning light is provided on both FWD and AWD vehicles. It is activated by the TCU indicating overheated ATF. The TCU logic will shift the transaxle as if in the power mode, moving more ATF volume through the cooler.

In the 1993 Model year the indicator light was discontinued **but** the logic for controlling hot ATF remained.

Starting in the 1995 model year the “HOT ATF” indicator light was reintroduced. Performing the same as in the past. However it has an added function. When the vehicle is started it is light momentarily. If it is flashing when the vehicle is started this indicates the TCU has detected an electrical failure. When the TCU is programmed to do so, it will flash a trouble code to assist in diagnostics.

Fail Safe System

NOTE: THE 4EAT'S ARE A HIGHLY RELIABLE TRANSMISSION. SHOULD AN ELECTRICAL COMPONENT MALFUNCTION, IT WILL ENTER FAIL-SAFE MODE.

Fail Safe Components and Failure Results

If a speed sensor fails, the remaining sensor signal will be used.

In case of throttle sensor failure, the idle contacts will signal the throttle opening. Line pressure will go to maximum at open throttle and it will go to minimum at closed throttle.

Although the inhibitor switch may fail, the manual valve will still be in the correct position for all selected ranges. In “P” and “N” however, it may effect start-up, therefore, there is a potential for a no-start condition. In Reverse, the TCU is passive. Therefore, an inhibitor switch failure has no effect. If multiple signals are seen in the forward ranges the inhibitor switch is ignored and there is no fourth gear.

If the 1-HOLD switch is defective, the system operates in the same manner as an inhibitor switch failure in the forward ranges.

If the MANUAL switch is defective (Legacy only), the transmission will shift normally in D position. It will operate the same as an inhibitor switch failure when the selector position 3 - 2 - 1.

If shift solenoids #1 or #2 malfunction, the TCU deactivates the other. This results in either 3rd gear or Reverse (when selected).

If duty solenoid “A” fails, line pressure goes to maximum.

If duty solenoid “B” fails, the torque converter lock-up will not occur.

If shift solenoid #3 malfunctions, the overrunning clutch is always “ON” and there will be engine braking during deceleration.

If duty solenoid “C” should fail, the 4WD control will be set to maximum and the rear wheels will always be powered.

4EAT Transmissions

Self Diagnostic System

The 4EAT self-diagnostic system has three modes: a user mode and two dealer modes. In the first instance, the user is notified through the POWER light when a malfunction occurs. The failure is communicated after the next ignition "OFF/ON" cycle. For a more detailed description of the user mode, see the appropriate troubleshooting section of the service manual.

NOTE: THE SYSTEM WILL FAIL SAFE FOR "LIMP HOME". WHEN A COMPONENT FAILS, THE LIGHT WILL NOT ILLUMINATE UNTIL THE IGNITION IS SWITCHED "OFF" AND THEN SWITCHED TO "ON" AGAIN.

For specific information on the self-diagnostics dealer modes, see the appropriate trouble shooting section of the service manual.

XT and L-Series Diagnostics

To enter in to the dealer mode to retrieve trouble codes it is necessary to operate the inhibitor switch in a specific sequence as outlined in the service manual. Once this has been performed the Power light will flash a code sequence.

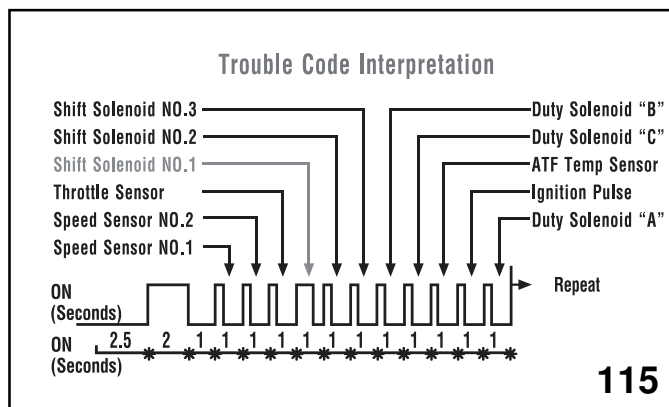

The TCU checks 11 components and displays the codes different than other on board diagnostic functions. When activated, the Power light flashes "OFF" for 2.5 seconds, "ON" for 2.5 seconds then 11 flashes. This sequence will repeat after the 11th flash.

Each component is assigned a position in the sequence (i.e. ignition pulse is position #10 and each position has a duty cycle of one second. Normal functioning components Flash on at a 10% duty, light "ON" for 0.1 second, light "OFF" for 0.9 second. Malfunctioning components flash on at a 60% duty, light "ON" for 0.6 second, light "OFF" for 0.4 second.

EXAMPLE: TCU PROGRAMMED FOR SELF-DIAGNOSTICS, SHIFT SOLENOID #1 DEFECTIVE POSITION #4 IN SEQUENCE. POWER LIGHT "OFF" FOR 2.5 SECONDS LIGHT "ON" FOR 2 SECONDS 3 FLASHES AT 10% DUTY (0.1 SECOND) 4TH FLASH AT 60% DUTY (0.6 SECONDS) 7 FLASHES AT 10% DUTY CYCLE REPEATS.

1990 –1994 Legacy, 1992 – 1995 SVX, 1993 – 1995 Impreza Diagnostics

The procedure to retrieve trouble codes is similar previous years. The manual button replaces the 1 – hold button function. Three modes are available

- Current trouble codes
- Past trouble codes (Long-term memory)
- Clear memory

The codes are communicated on the POWER light. There are 12 codes for the AWD and 11 codes for the FWD vehicles. They are displayed similar to fuel system codes, one long flash = 10 (1.2 seconds), one short flash = 1 (0.3 seconds). For example – one long, two short = code 12.

Select Monitor Analysis

The select monitor is a powerful tool for analysis of an electrical condition.

This form of analysis is the preferred troubleshooting/self-diagnostic method. The select monitor identifies current problems, past problems (through long-term memory), and indicated actual circuit and component performance. Other functions that can be useful diagnostic aids are graphing; LED display of switched components, Max. & Min. readings, and save data and play back.

Also the select monitor Oscilloscope function serves to assist in finding intermittent electrical conditions using the trigger function.

Depending on the model and year vehicle the data list displayed can be extensive. As will be discussed later, OBD-II functions also have freeze frame data on 1995 and newer vehicles.

4EAT Transmission

1995 – 1998 Legacy, 1996 – 1998 Impreza, 1996 – 1997 SVX, 1998 Forester, Diagnostics / OBD – II Vehicles

AT Oil Temperature light operation operates under the following conditions. Ignition switch on / engine off is the bulb check mode, light remains on. Normal - Ignition switch on / Engine on light remains on for 2 seconds from engine start.

NOTE: A FAILURE IS NEVER REPORTED VIA THE AT OIL TEMP LIGHT DURING CURRENT OPERATION. THE TCU WAITS UNTIL THE NEXT IGNITION CYCLE TO DISPLAY THE FOLLOWING AT OIL TEMP LIGHT CONDITION. THEREFORE THE DRIVER MAY DETECT AN ABNORMAL DIRVEABLITY CONDITION (FAIL SAFE OPERATION) WITH NO AT OIL TEMP LIGHT INDICATING A FAILURE.

Abnormal - Ignition switch on / engine on the light remains on for 2 seconds from engine start. Off for 0.25 seconds on for 0.25 seconds 4 times then off for 2 seconds. Cycle repeats 4 times for a total of 16 Blinks

Abnormal ATF Temperature is too high. AT temp light comes on and stays on until ATF temperature returns to normal.

Trouble Codes

The procedure to retrieve trouble codes similar to previous models except, grounding terminal # 5 of connector B82 a 6 pole black, right side of steering column. Trouble codes will be displayed through AT Temp light with the following differences. There are 14 possible trouble codes communicated from the TCU. They are displayed in the same format as old fuel system trouble codes, long Flash = 10, short flash = 1. For example: 2 long and 4 short = code 24, Duty Solenoid "C".

The clear memory procedure is simple and quick, just remove fuse No. 14 for at least one minute.

OBD - II

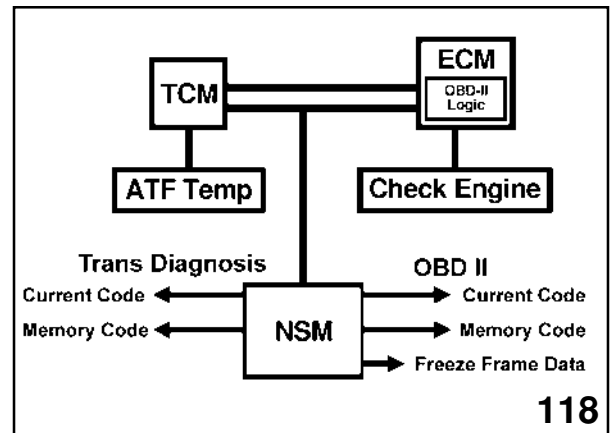

OBD - II Operation Overview

The system monitors components and their operation, conducting continuity and performance checks. The check engine light or MIL illuminates when a code is set into ECU memory. Problems with the 4EAT are communicated from the TCU to the ECU.

There are 2 trouble codes that are generated as soon as a problem occurs, turning on the MIL. With 22 others requiring a fault or error during two consecutive trips, before turning on the MIL. A trip is defined as a driving pattern in which test parameters are reached for a given time. A failed trip will be erased if the next trip is a good one.

Transmission codes generated in OBD-II have freeze frame information available on the select monitor in the fuel system section of data display.

OBD - II purpose

The Society of Automotive Engineers in cooperation with the EPA have in accordance with regulation J2012 of the 1990 Clean Air Act, established DTC's that are to be used by the automobile industry beginning with the 1995 model year. DTC's that use a "PO" prefix are SAE assigned. DTC's that use a "P1" prefix are categorized by SAE but are assigned by a vehicle manufacturer.

OBD-II checks a component and its operation similar to OBD-1, which is used on pre 1995 model vehicles. OBD-I for example, checks the "Torque Converter Clutch System Electrical" by monitoring for minimum and maximum voltage signals. OBD-II also performs this function. For example examine DTC P0743

4EAT Transmissions

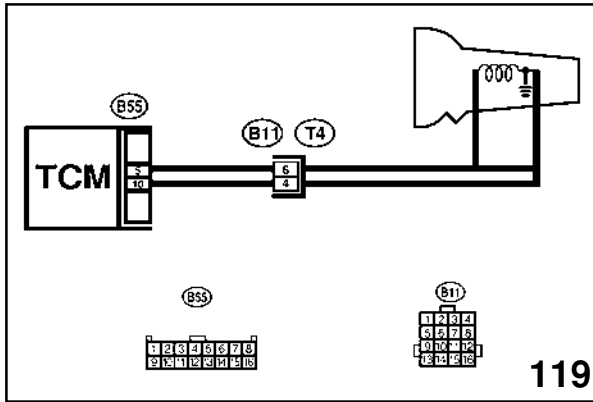

The TCM continuously monitors duty solenoid B Circuit. A fault will register if the following conditions are met:

1. When the TCM supplies an ON signal to the coil of the solenoid, the voltage from the coil is lower than preestablished parameters.
2. When the TCM supplies an OFF signal to the coil of the solenoid, the voltage from the coil is higher than preestablished parameters.

Condition (a) or (b) will cause the DTC to register in the ECM memory on OBD-I or OBD-II systems.

OBD-II in addition to the previous will monitor for performance of the "Torque Converter Clutch System". For example examine DTC P0740.

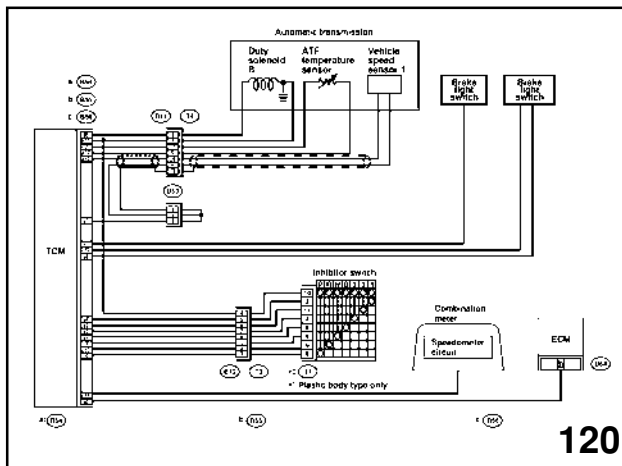

The detecting condition: Slipped wheel RPM (absolute value of difference from transmission input RPM computed from engine speed and vehicle speed) continues greater than $[40 + \text{vehicle speed} / 2]$ for 10.2 seconds. When the lockup duty ratio is greater than 90% in lock up control mode detected by the TCM.

The TCM continuously monitors the torque converter clutch system. A fault will register if the following condition is present:

Engine speed is equal to or greater than output shaft speed (speed sensor 1) multiplied 4th gear ratio multiplied by 9/8.

The following conditions must be met before the test is performed.

1. The transmission is in 4th gear.
2. The duty ratio for lockup duty solenoid is equal to or greater than 90%

The DTC will set and the MIL will illuminate if a fault is registered during two consecutive trips.

Control Unit Networking

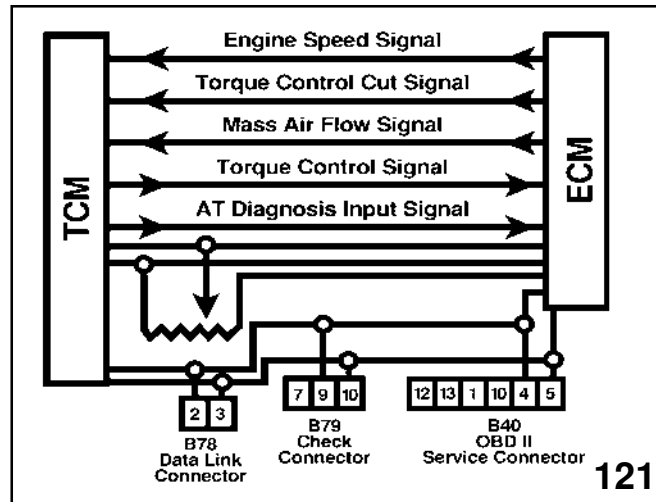

Both the Fuel Injection control unit and the Transmission control unit share processed information and sensor input by shared signals.

Engine speed signal is sent to the TCM from the ECM influencing Torque Converter lock-up.

Torque Control Cut signal is sent to the TCM from the ECM preventing fuel cut under certain conditions. Diagnostics are provided by the TCM as code 16, signal diagnostics are not provided in OBD – II.

Torque control signal (unique from the Torque Control Cut signal) is created in the TCM logic to communicate to the ECM that torque reduction (fuel cut) is required to reduce shift shock during a wide-open throttle up-shift. Diagnostics are provided by the TCM as code 25 and also in OBD – II logic as DTC P1103.

Mass Airflow signal is sent to the TCM from the ECM as a back up for influencing the shift points in the event of a throttle position signal loss. Line pressure is also affected by the Mass Airflow sensor input, lowering the line pressure during up shifts reducing shock. There are no corresponding onboard diagnostic codes for this signal in the TCM.

4EAT Transmission

Automatic Transmission Diagnosis Input Signal represents an electrical check, for the circuit that networks the TCM and ECM communicating diagnostic information to the ECM. This signal has no corresponding 4-EAT code.

Troubleshooting and Adjustments

Preliminary Inspection

Check the following:

1. Fluid level
2. ATF leaks
3. Road Test:
 - Check proper shift points
 - Engine performance
4. Correctly adjusted throttle sensor
5. Gearshift cable adjustment
6. Correct stall test results
7. Inhibitor switch connections
8. Correct pressure test results

Gearshift Cable Adjustment

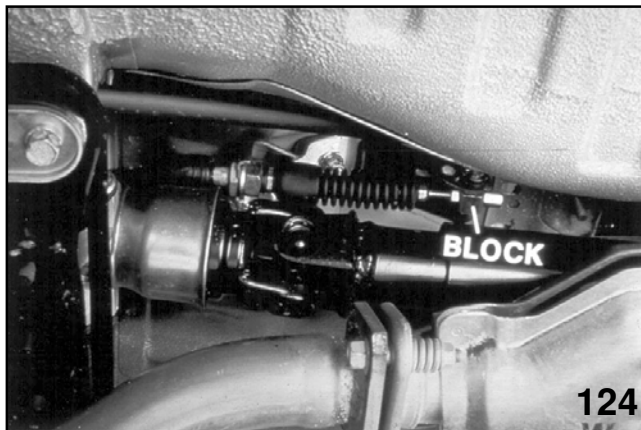

Place the transmission in neutral with the engine "OFF". Then loosen the locking nut and the adjusting nut. Push the shift lever arm rearward and tighten the adjusting nut until it contacts the connecting block. Finally, secure the cable with the locking nut and double check the operation.

After adjusting the gearshift cable, verify the correct inhibitor switch position. Remove the cable from the inhibitor switch in order to perform the adjustment. The switch must be in neutral.

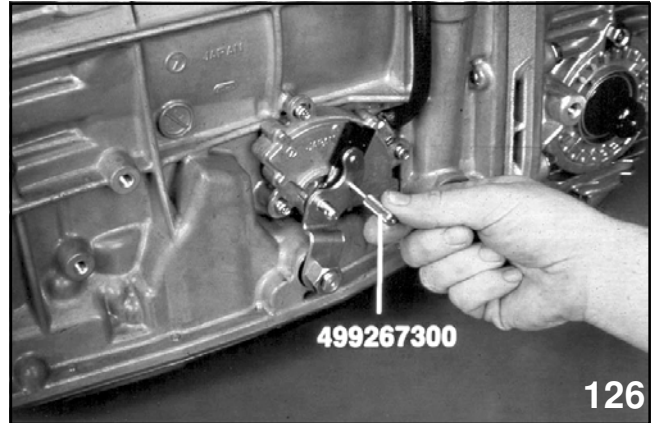

Then insert the special tool #499267300 Stopper Pin through the 2 levers of the switch into the depression in the switch body. Next, loosen the 3 retaining bolts and rotate the inhibitor to adjust. Finally, reinstall the cable and reconfirm the cable adjustment.

Stall Test

The stall test checks the operating condition of the AT clutches the torque converter, and the engine. Perform these checks in "D", "3", "2", and "Reverse".

Stall Test Results

Higher than normal RPM indicates one or more of the following:

- Slippage of the forward clutch
- O.W.C. not holding
- Low/Rev. brake slipping
- Overall low line pressure

Lower than normal RPM indicates one or more of the following:

- Incorrect throttle adjustment
- Poor engine operation
- Torque converter stator slippage

Time Lag Test

The time lag test checks the operation of the forward clutch, the reverse clutch, the low/reverse brake, O.W.C. 3-4, and O.W.C. 1-2.

Perform this test at operating temperature. Idle the engine with the A/C "OFF". Confirm the proper idle speed in "N" and correct if necessary. Then shift into "D" and measure the time (seconds) to full engagement. It should take less than 1.2 seconds. Then shift into "R" and measure the time. It should take less than 1.5 seconds.

4EAT Transmission

Time Lag Results:

If the time takes longer from “N” to “D”, it may indicate one or more of the following:

- Low line pressure
- Worn forward clutch
- O.W.C. problem

If the time takes longer from “N” to “R”, it may indicate one or more of the following:

- Low line pressure
- Worn reverse clutch
- Worn low/rev brake

Pressure Test

Perform a pressure test when all the circuits show evidence of slippage or when the circuits show negative results from the time lag test.

This test should also be performed if there is excessive shift shock, delayed shifting, or if the vehicle is immobile.



Perform this test by connecting the pressure gauge to the “oil pump outlet” test port in order to determine the overall line pressure. Should a particular component be suspected, perform pressure tests at its unique test port.

Refer to the Service Manual, Sec. 3-2, [S1D0] for other ports. Check for minimum and maximum values at each port.

On Car Service/Adjustments

The following can be performed on the vehicle:

- Checking/changing fluids
- Band adjustment
- Valve body servicing
- Shift Linkage adjustment/replacement
- Inhibitor switch adjustment/replacement
- Harness repair/replacement
- Transfer clutch assembly (servicing/replacement)
- Speed sensors replacement

4EAT Transmission

302 Module Lesson Plan Bulletins

The slide numbers are the same as the latest edited version

Bulletin #	Date	Description
16-36-90	2/26/90	Torque converter bleed down, check valve added
16-37-90	3/26/90	Drive line binding on sharp turns PDI
16-39-90	4/9/90	Broken differential dip stick
16-40-90	4/9/90	Correction to part numbers in TSB 16-36-90
16-42-90	8/20/90	Flushing the Transmission oil cooler
16-49-90	12/31/91	Provide copy as hand out (brake band adj.)
16-50-92	3/6/92	Checking O.W.C. 1-2 & 3-4 for proper installation
16-53-92	7/9/92	Cooler hose routing, cooler flushing
16-54-92	11/27/92	Gear reduction drive shaft replacement (Orifice plug separate)
16-55-93	5/3/93	More filter kit information
16-56-93	5/12/93	SVX filter kit installation
16-58-94	3/8/94	Oil pump gasket or case not modified could show up in a failed time lag test. Or stall test in extreme failure. High clutch failure, Bearing change and oil holes
16-59-94	4/20/94	Prevention of repeat planetary gear failures
16-60-94	5/16/94	Installation of Speedo cable adapter
16-61-94	6/1/94	Updated information for TSB 16-58-94
16-62-97	5/16/97	Transfer clutch binding and/or bucking on turns

4EAT Transmission

302 Module Service Help-Line Updates

The slide numbers are the same as the latest edited version

Date Page Subject

04/91	2	Metallic noise on light acceleration / Torque Converter installation
06/91	2	4EAT slow engagement / Torque Converter drain back
06/91	3	Transmission oil cooler flushing
06/91	3	Failure after replacement of reduction shaft
11/91	2	Oil pump cover bolt torque clarification
11/91	4	Loose ground affects / no power light and early up-shift
08/91	2	AWD binding on corners
01/92	2	Thrust bearing identification
06/92	3	Servicing and repairs General info
08/92	4	Auxiliary filter replacement
08/92	4	Auxiliary filter installation caution
10/92	4	Torque bind complaints
11/92	3	Batteries affecting auxiliary filter lines
11/92	3	Tires affecting AWD
12/92	2	Reassembly Cautions
02/93	2	Torque Converter lock up clutch causing engine stall
02/93	3	Auxiliary filter
04/93	2	Modified pump gasket
05/93	2	Low temperature operation
06/93	2	Squeaking noise from Torque Converter
10/93	5	Speedometer cable adapter
10/93	5	Towing cautions
12/93	3	Swapping Duty solenoid "C" for testing purposes
05/94	6	Torque Converter bolt removal
05/94	6	High clutch seizure / failure
06/94	6	Gasket and Seal kit
09/94	4	No movement in any gear
12/94	4 & 5	Shift problem diagnosis
05/95	5	Clicking noise from transmission
09/95	5	Low or erratic line pressure
02/96		ATF cooler hose re-routing
04/96		Change in pinion shaft
05/96		Delayed engagement into drive when warm
07/96		extension case roller bearing removal
07/96		4EAT systems diagnosis
08/96		Binding in turns
09/96		Transfer clutch chatter
04/97		Speed Sensors
08/97		Engine RPM goes to zero when coming to a stop
01/98		Rear axle binding on turns

4EAT Transmission

4EAT Valve Body Bolts

Order of Bolt Assembly

Note: See chart on next page

- 1 bolt at location 1
- 1 bolt at location 2
- 1 bolt at location 3
- 2 bolts at location 4
- 16 bolts at location 5
- 6 bolts at location 6 (keep 4 screen bolts)
- 2 bolts at location 7

INSTALL VALVE BODY IN CASE

- 11 bolts at location 8

INSTALL SCREEN

- 4 bolts at location 6 (4 screen bolts)

INSTALL OIL COOLER PIPE

- 8 bolts at location

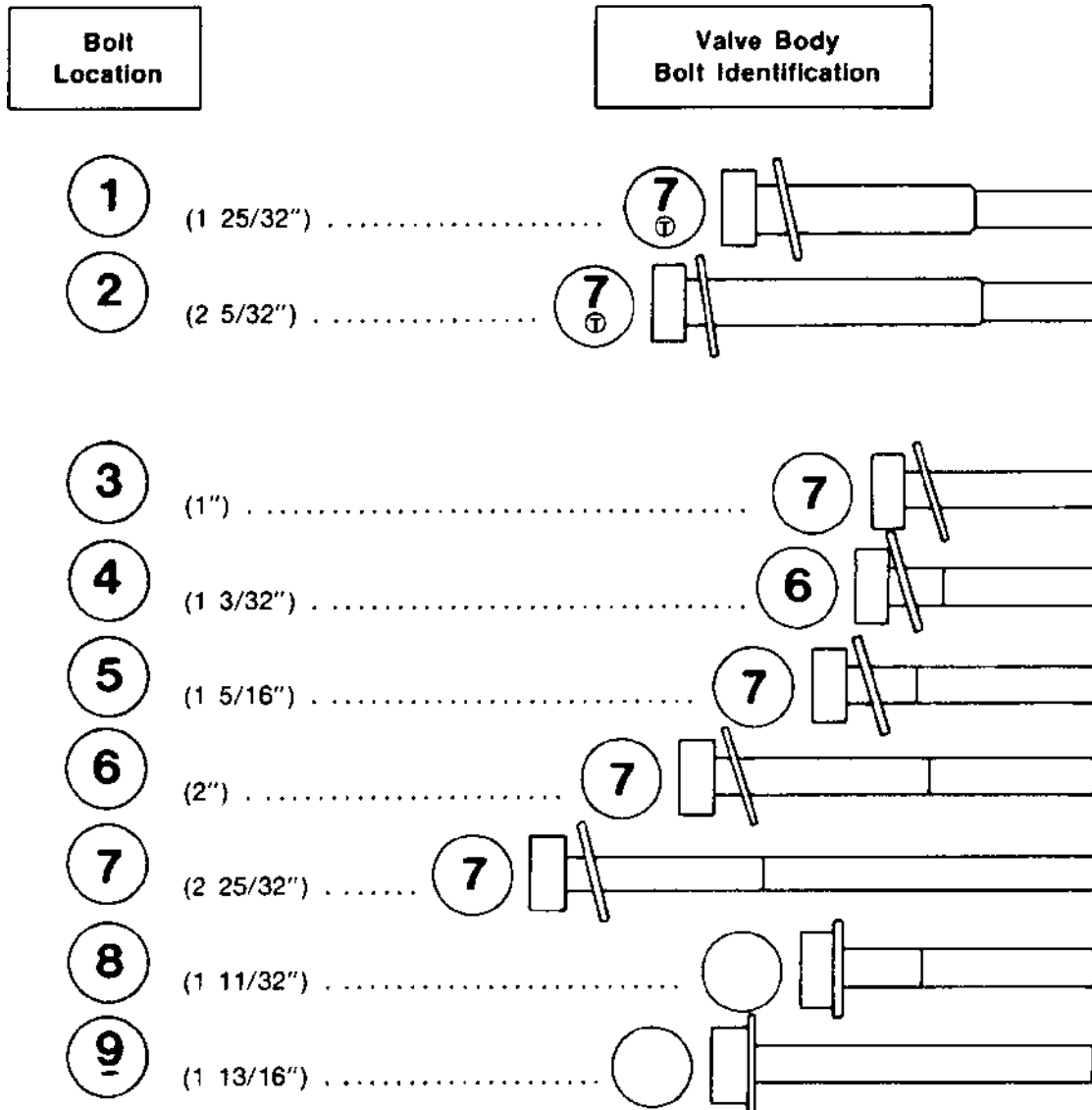

4EAT Transmission

