

2. Pre-road Test Inspection

O: SEAT ADJUSTER AND SEAT BELTS

CHECK POINTS

1. Front and rear seats, and their facing materials
2. Front seat operation
3. Rear seat folding operation
4. Seat belts and their fit
5. Installing procedure for child anchor

● Manual three-point type

The seat belt warning light on the instrument panel comes on for approximately six seconds with the ignition switch "ON".

And the warning chime sounds if the driver's seat belt is not fastened.

Make sure that the warning system works normally.

● Installing procedure for child anchor

When top strap anchor is used for rear seat:

1) For Canada models, the anchor set is inside the glove box. Take it out and check that its components are assembled as shown in figure.

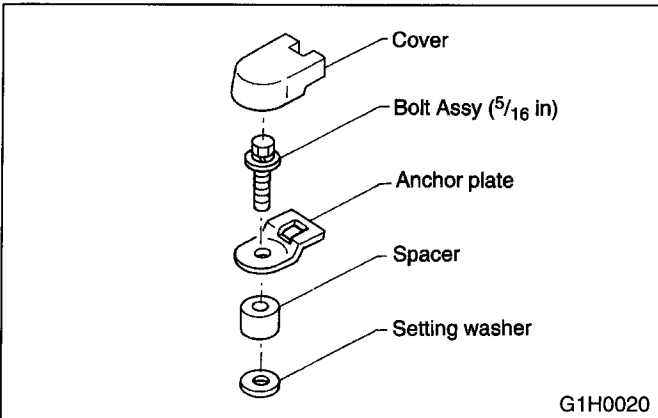

2) The anchor installation points are covered with caps. Remove the cap at the desired anchor installation points.

Sedan and Coupe

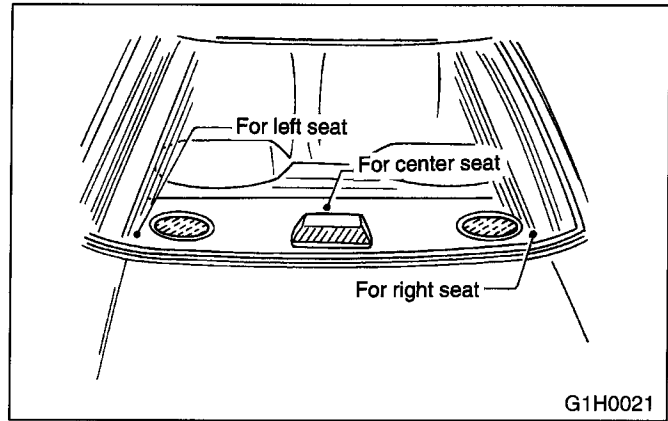

Wagon

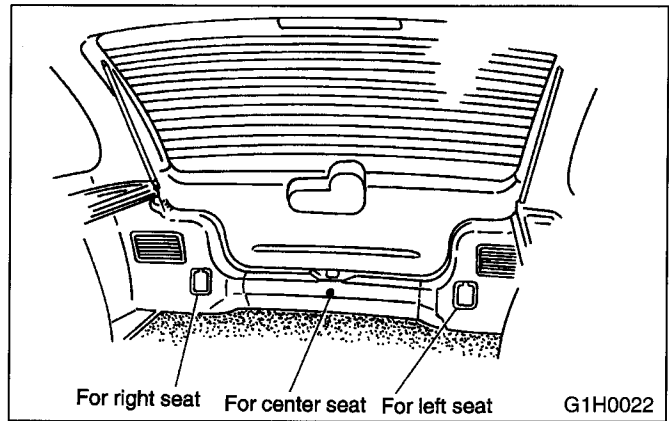

3) Install the anchor at the installation point. Tighten the bolt so that the anchor is completely secured.

4) Attach the cover to the anchor plate.

5) Attach the hook of the top strap to the anchor.

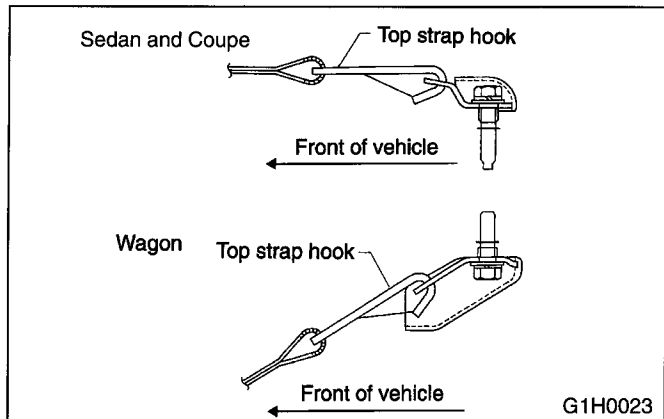

CAUTION:

- Be sure to install the plate anchor set in the correct direction.
- Before tightening the plate anchor set, position the plate in the pawl of the cover. Do not allow the cover base to be caught between the plate anchor and spacer.
- Always use a genuine top strap anchor.