

2. Body Datum Points

1. ENGINE COMPARTMENT AND ROOM

COUPE MODEL

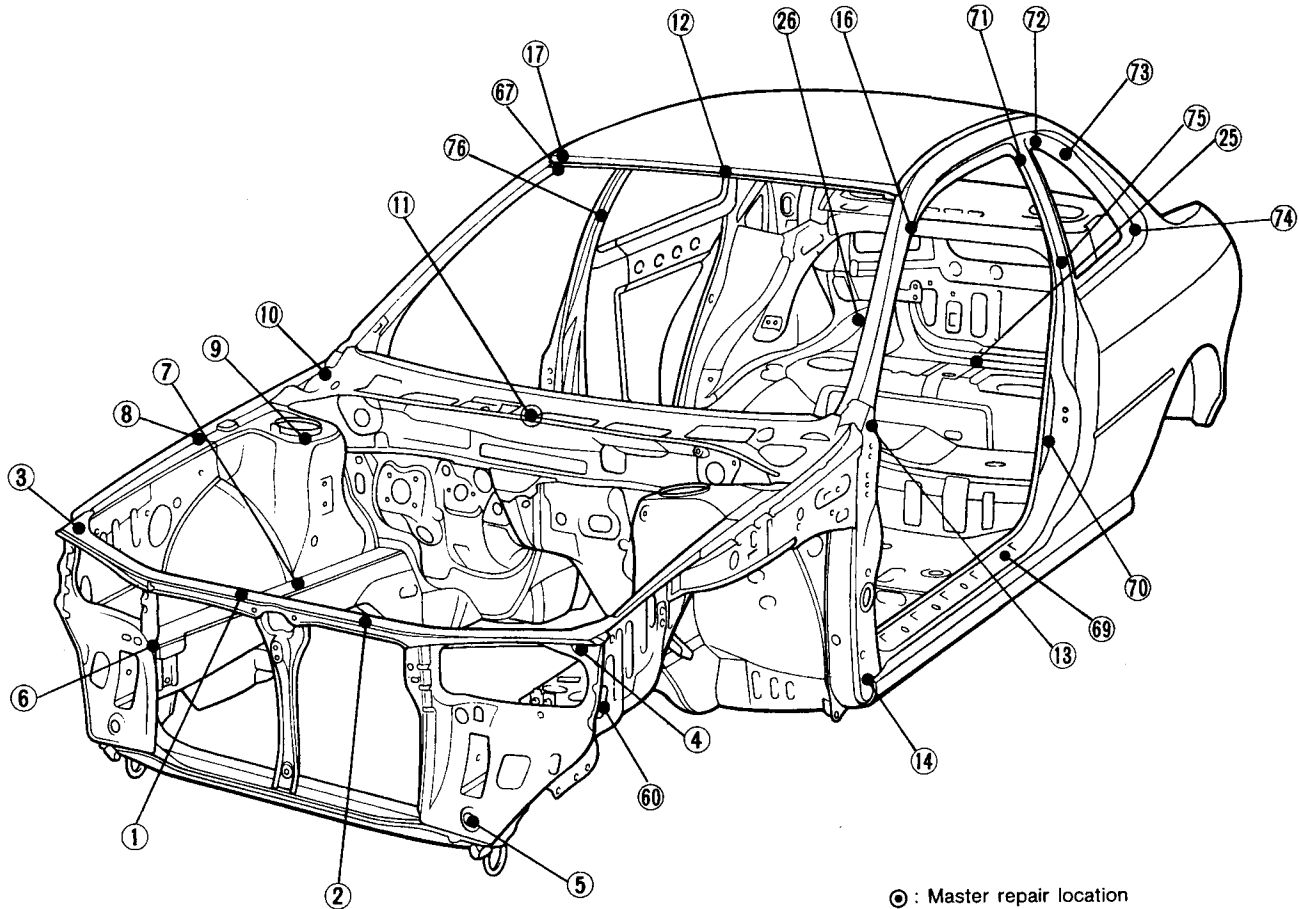

⊙ : Master repair location

G5M0643

- | | |
|---|---|
| ① Radiator panel (UPR) repair bolt hole M8 (Right) | ⑩ Retainer attaching square hole 7 mm (0.28 in) (Symmetrical) |
| ② Radiator panel (UPR) repair bolt hole M8 (Left) | ⑪ Sun visor attaching hole 20 mm (0.79 in) dia. (Symmetrical) |
| ③ Fender attaching bolt hole M6 (Symmetrical) | ⑫ Spare tire attaching bolt hole M8 |
| ④ Headlight attaching bolt hole M6 (Symmetrical) | ⑬ Air draw hole 7 mm (0.28 in) dia. (Symmetrical) |
| ⑤ Radiator panel side gauge hole 24 mm (0.94 in) dia. (Symmetrical) | ⑭ Fender attaching bolt hole M6 (Symmetrical) |
| ⑥ Front bumper mounting hole 14 x 17 mm (0.55 x 0.67 in) dia. (Symmetrical) | ⑮ Front glass attaching hole
Right 6.5 mm (0.256 in) dia.
Left 6.5 x 10 mm (0.256 x 0.39 in) dia. |
| ⑦ Front crossmember attaching bolt hole 12.4 mm (0.488 in) dia. (Symmetrical) | ⑯ Wax coat hole 20 mm (0.79 in) dia. (Symmetrical) |
| ⑧ Fender attaching bolt hole M6 (Symmetrical) | ⑰ Door switch attaching hole 13.5 mm (0.531 in) dia. (Symmetrical) |
| ⑨ Front strut mounting hole 10 mm (0.39 in) dia. (Symmetrical) | ⑱ Retainer attaching square hole 8 mm (0.31 in). (Symmetrical) |
| ⑩ Hood hinge attaching bolt hole M8 (Symmetrical) | ⑲ Rear quarter glass attaching hole 8 mm (0.31 in) dia. (Symmetrical) |
| ⑪ Cowl panel mounting hole 5 mm (0.20 in) dia.
(Located in center of vehicle.) | ⑳ Rear quarter glass attaching hole 7 mm (0.28 in) dia. (Symmetrical) |
| ⑫ Front rail (Inner) mirror attaching bolt hole 8 mm (0.31 in) dia. | ㉑ Rear quarter glass attaching hole 8 x 5.5 mm (0.31 x 0.217 in) dia. (Symmetrical) |
| ⑬ Fender attaching bolt hole M6 (Symmetrical) | ㉒ Retainer attaching square hole 8 mm (0.31 in). (Symmetrical) |
| ⑭ Front pillar gauge hole 20 mm (0.79 in) dia. (Symmetrical) | ㉓ Seat belt anchor attaching bolt hole 16 mm (0.63 in) dia. (Symmetrical) |

2. LUGGAGE COMPARTMENT AND ROOM (SEDAN AND COUPE)

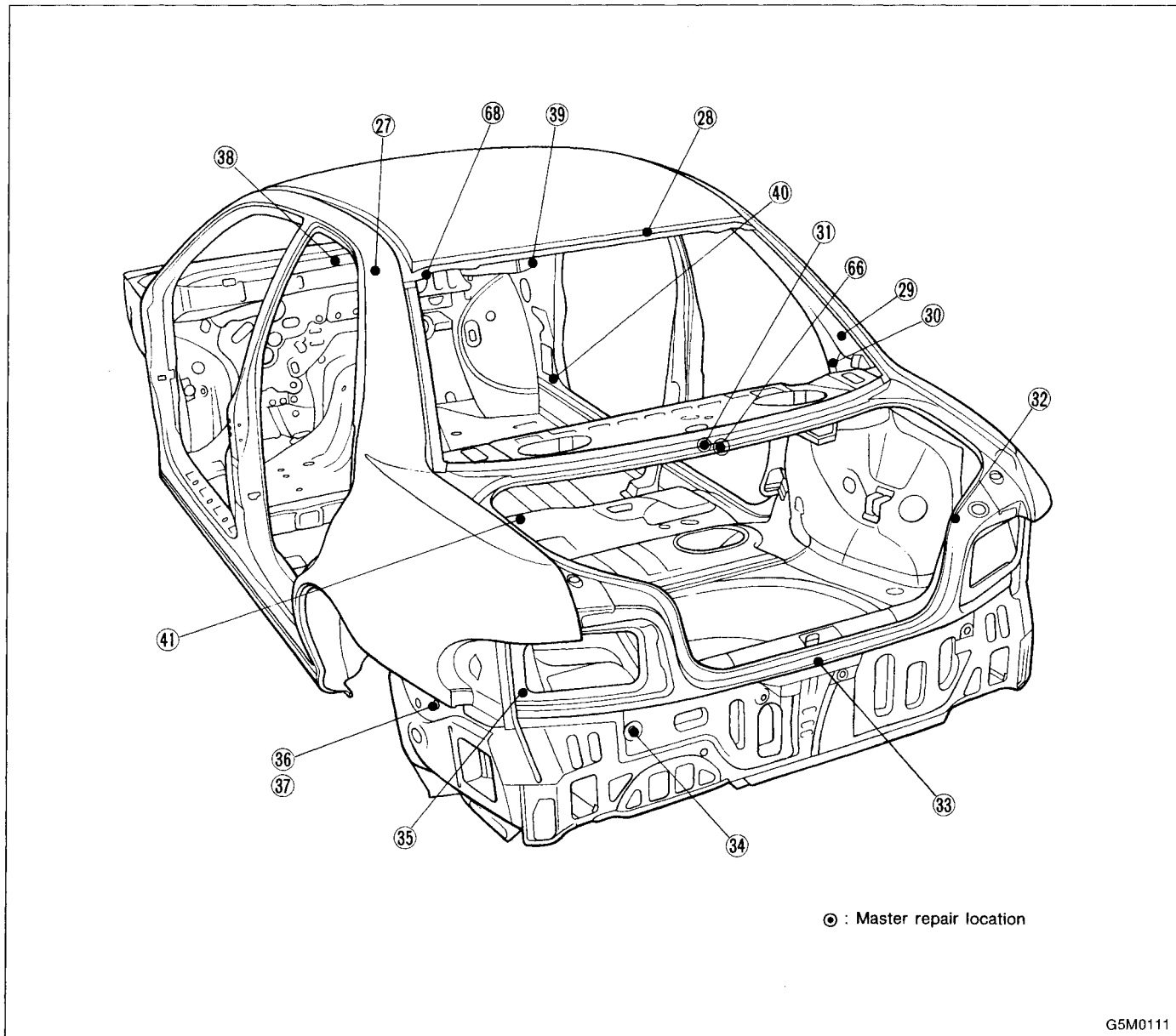

G5M0111

- 27 Rear pillar (Inner) gauge hole 8 mm (0.31 in) dia. (Symmetrical)
- 28 Rear roof trim attaching hole 8 mm (0.31 in) dia. (Symmetrical)
- 29 Rear quarter trim attaching hole 8 mm (0.31 in) dia. (Symmetrical)
- 30 Seat belt anchor attaching bolt hole (Symmetrical)
- 31 Reinforcement (Rear panel rear) repair locator (Located in center of vehicle)
- 32 Rear corner patch at flange (Symmetrical)
- 33 Rear skirt (UPR) cutout (Repair locator)
- 34 Rear skirt gauge hole 20 mm (0.79 in) dia. (Symmetrical)
- 35 Rear combination light mounting hole 9 mm (0.35 in) dia. (Symmetrical)
- 36 Rear quarter bumper side gauge hole 20 mm (0.79 in) dia. (Left)
- 37 Rear quarter bumper side gauge hole 20 mm (0.79 in) dia. (Right)
- 38 Instrument panel attaching square hole 22 x 34.5 mm (0.87 x 1.358 in) (Right)
- 39 Steering support beam attaching bolt hole M8 (Symmetrical)
- 40 Front pillar (Inner) gauge hole 10 mm (0.39 in) dia. (Symmetrical)
- 41 Floor mat attaching clip hole 8 mm (0.31 in) dia. (Symmetrical)
- 66 Rear panel (Center) repair locator (Located in center of vehicle.)
- 68 Rear glass attaching hole
(Right): 6.5 mm (0.256 in) dia.
(Left): 6.5 x 10 mm (0.256 x 0.39 in) dia.

5. DATUM POINT LOCATION

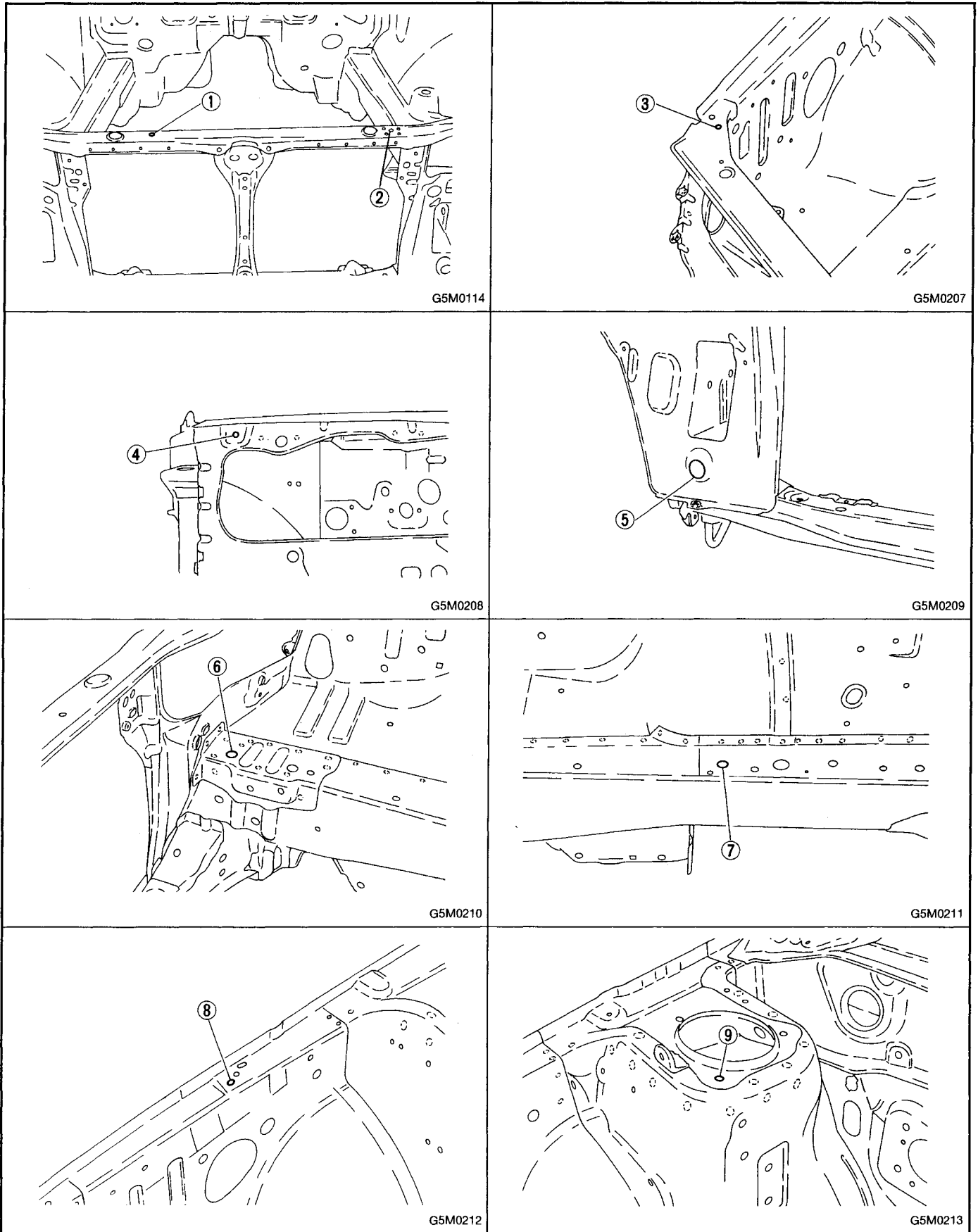

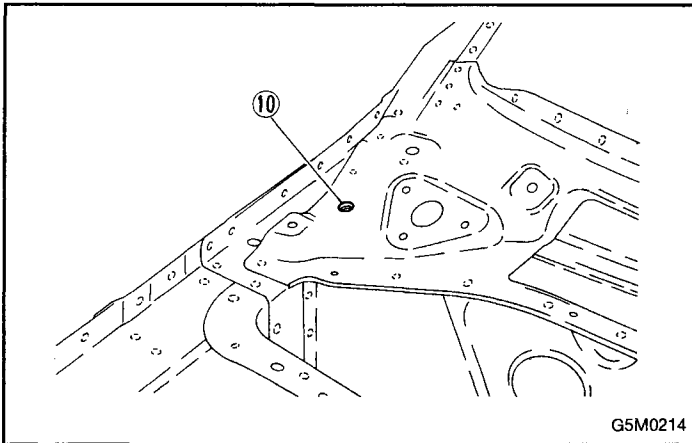

G5M0214

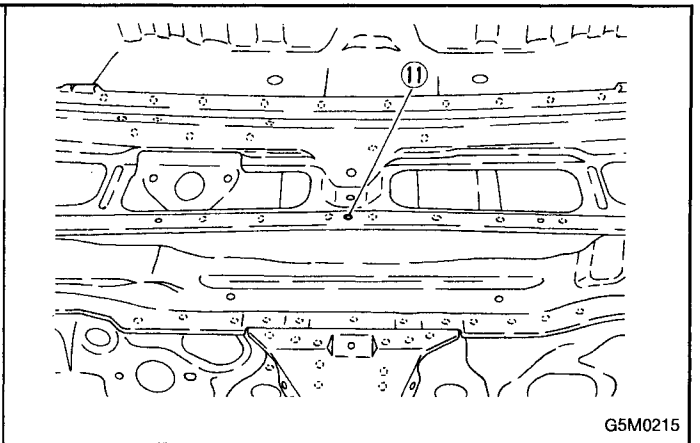

G5M0215

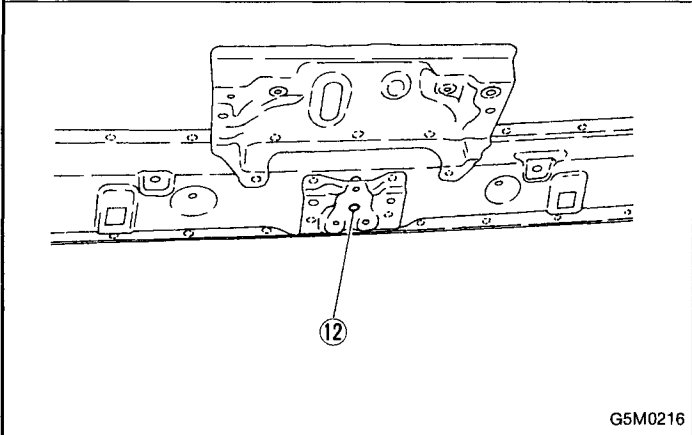

G5M0216

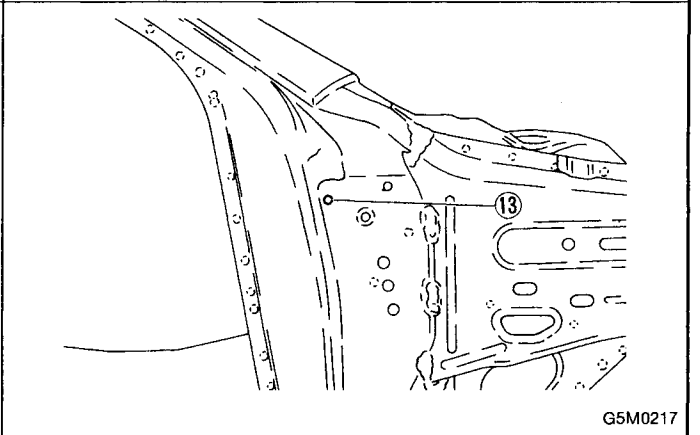

G5M0217

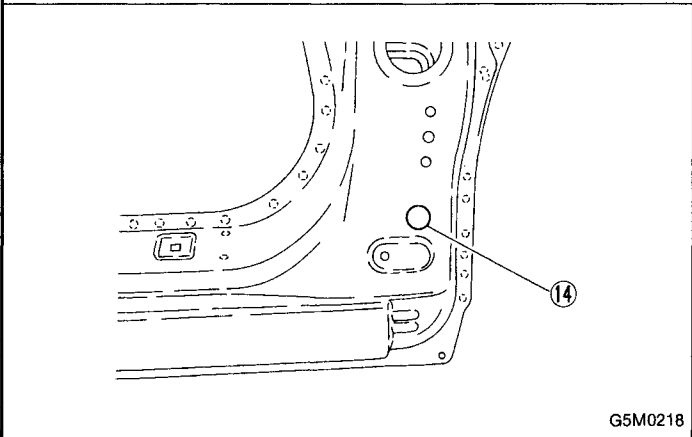

G5M0218

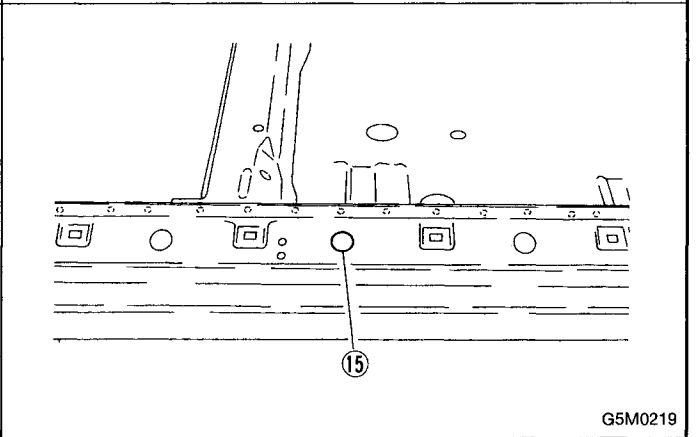

G5M0219

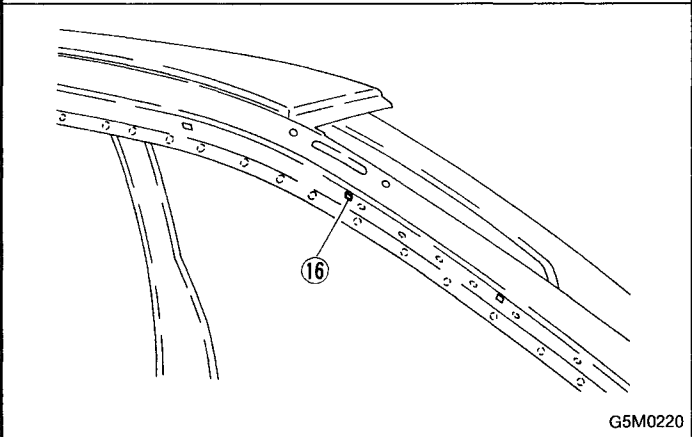

G5M0220

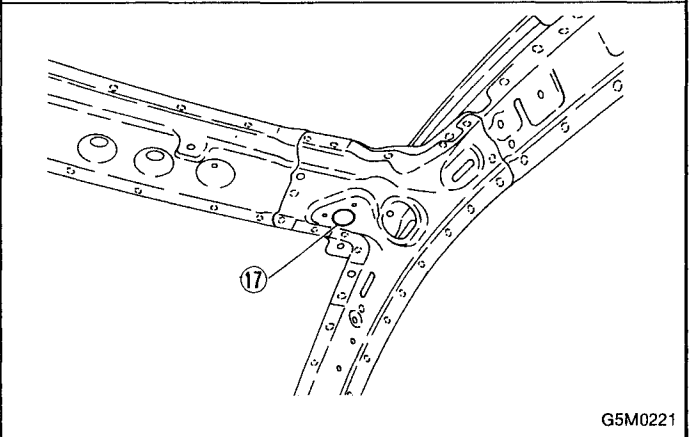

G5M0221

2. Body Datum Points

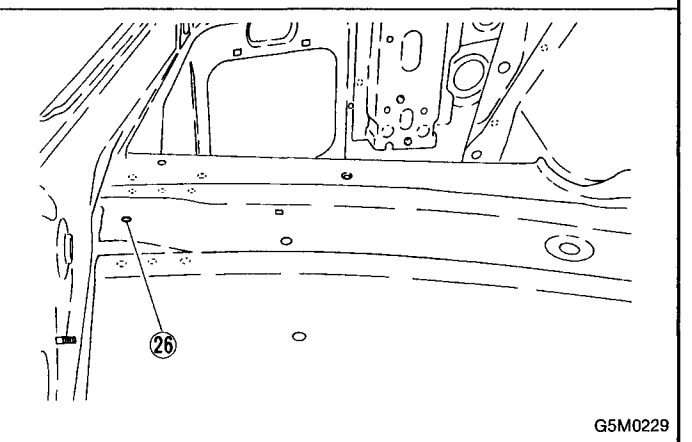
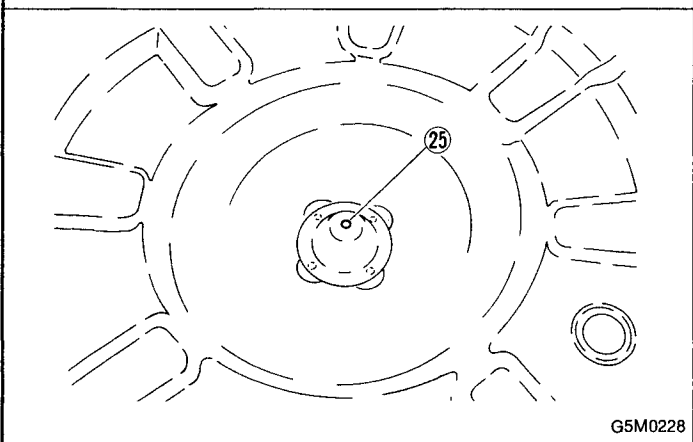
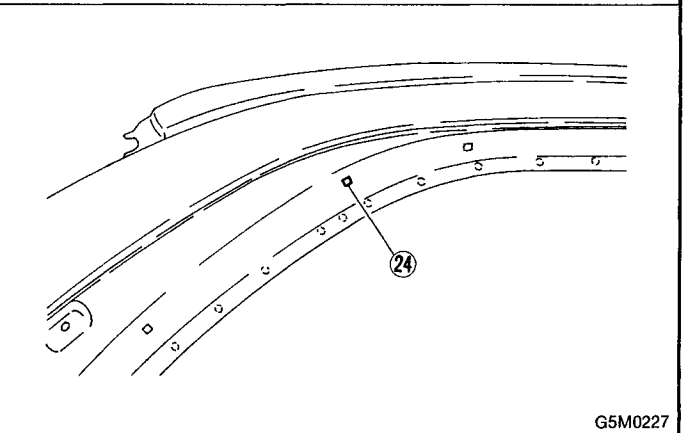
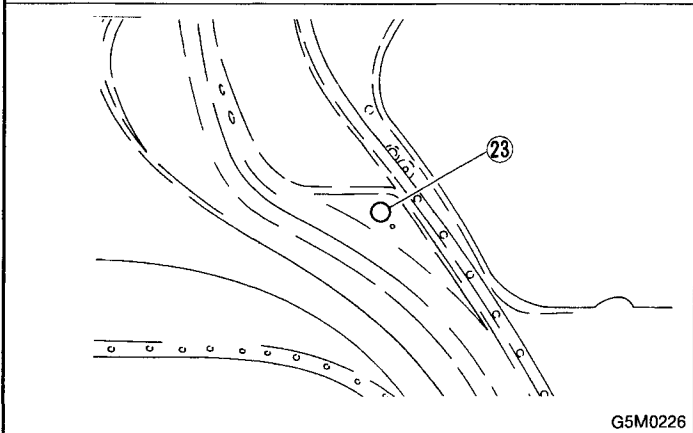
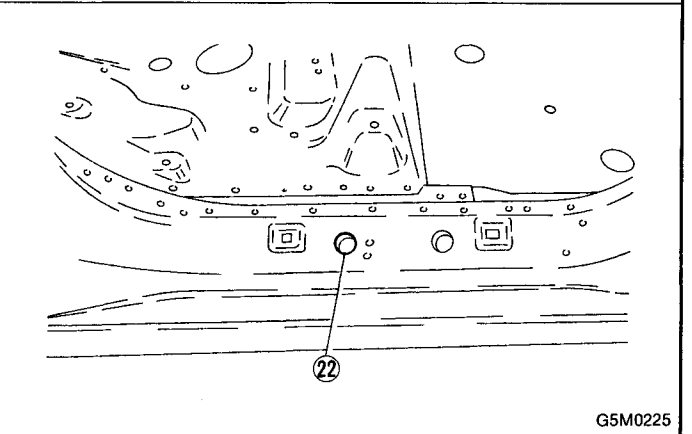
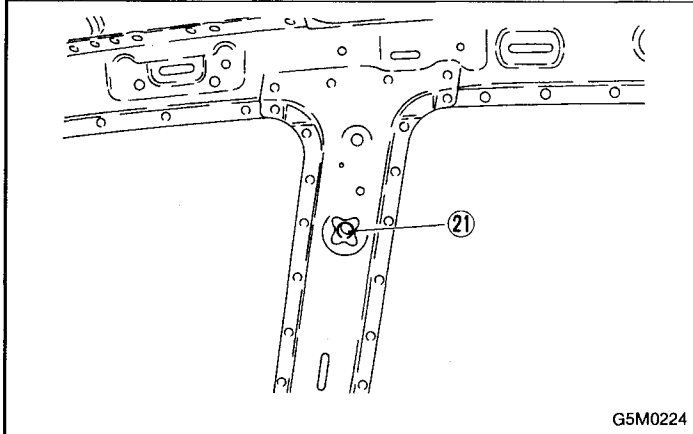
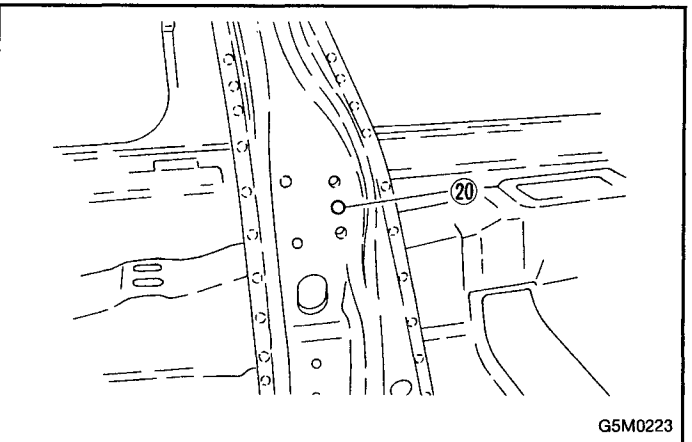
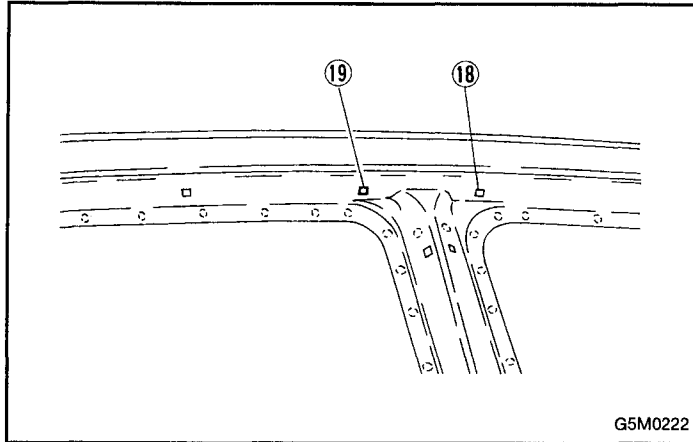

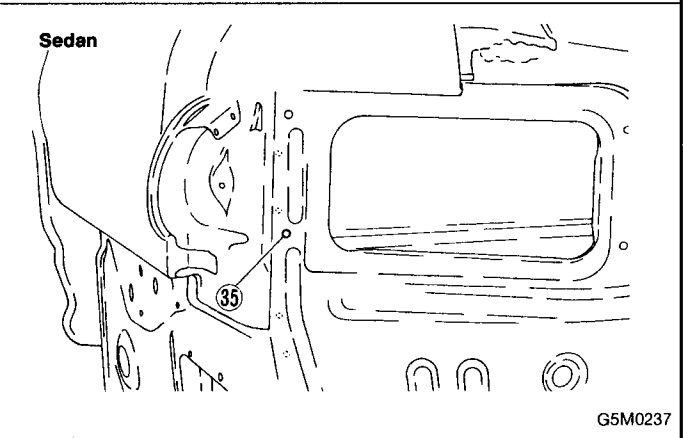
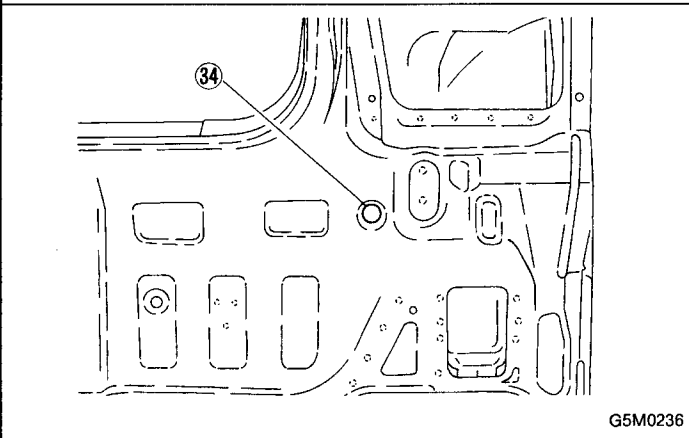
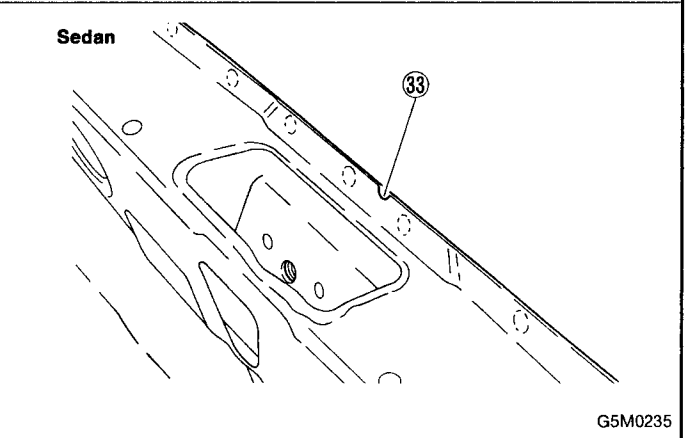
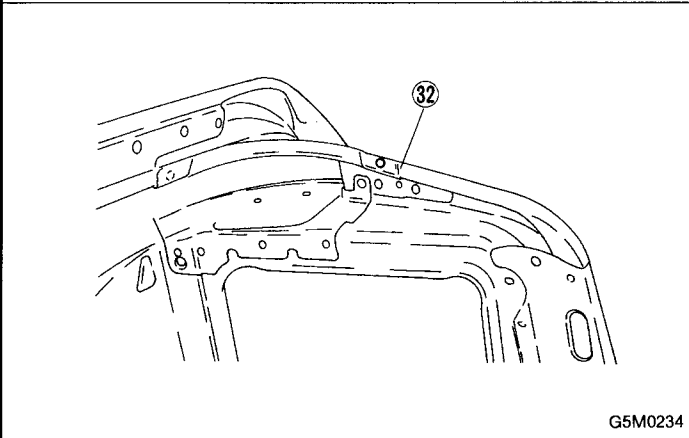
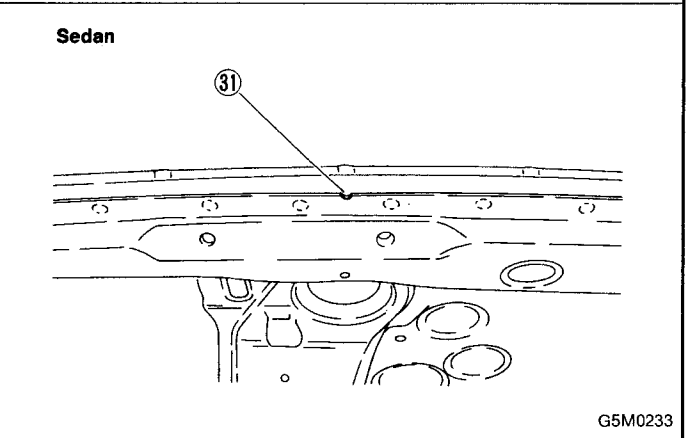
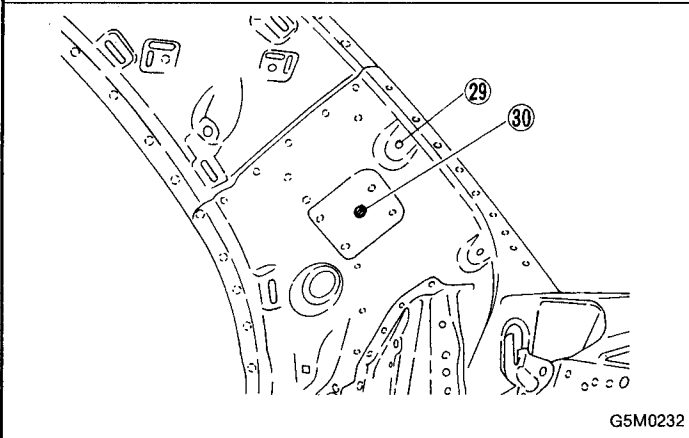
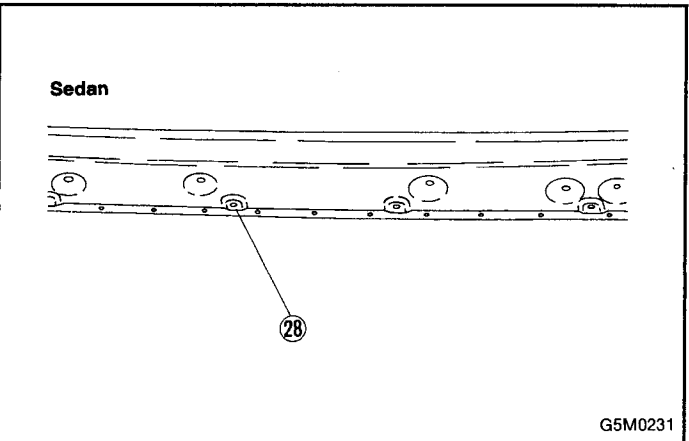
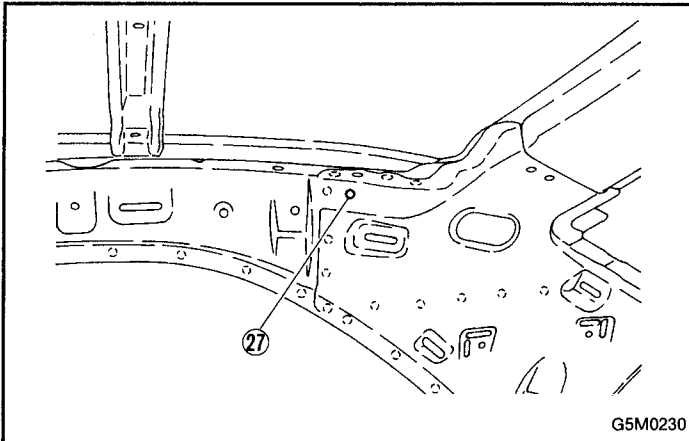

2. Body Datum Points

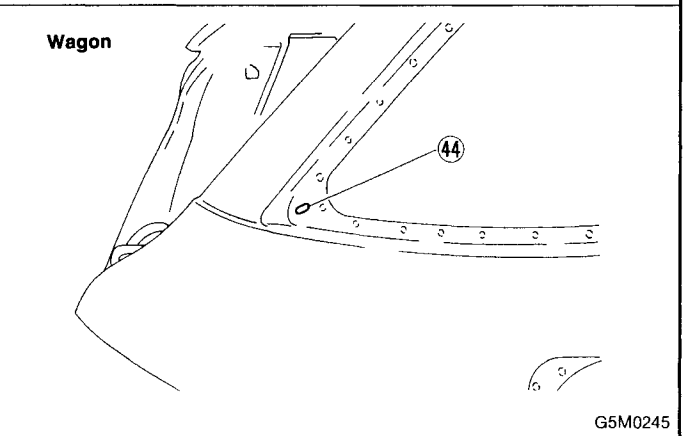
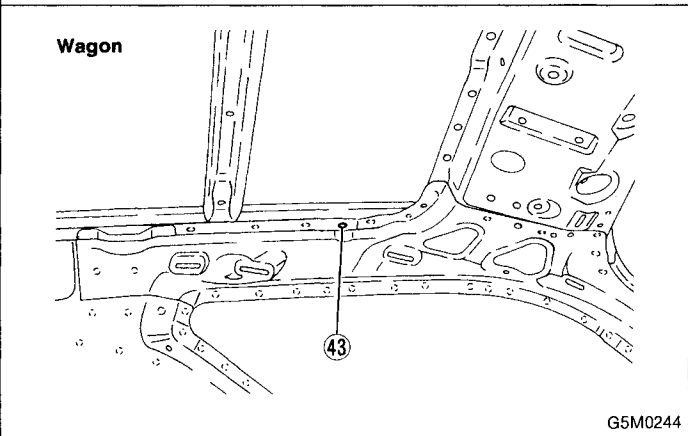
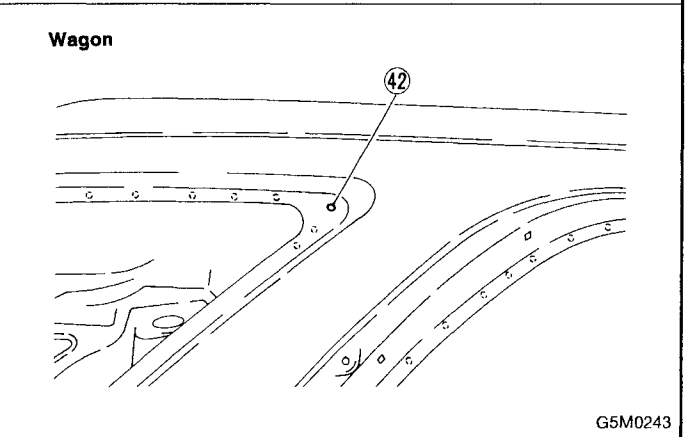
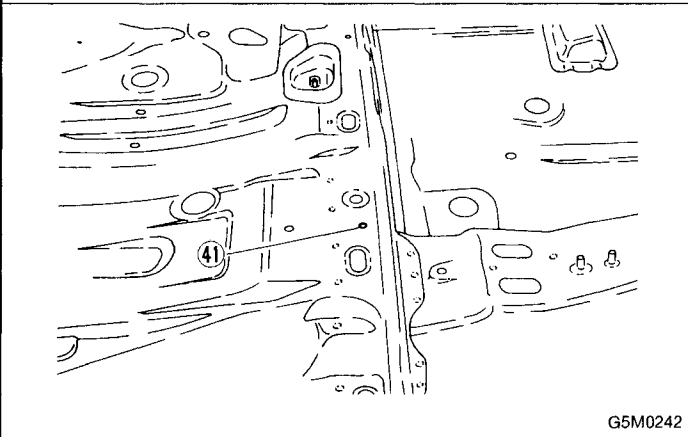
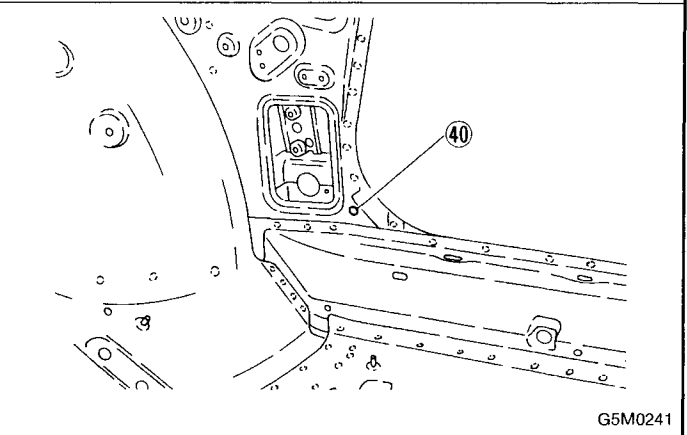
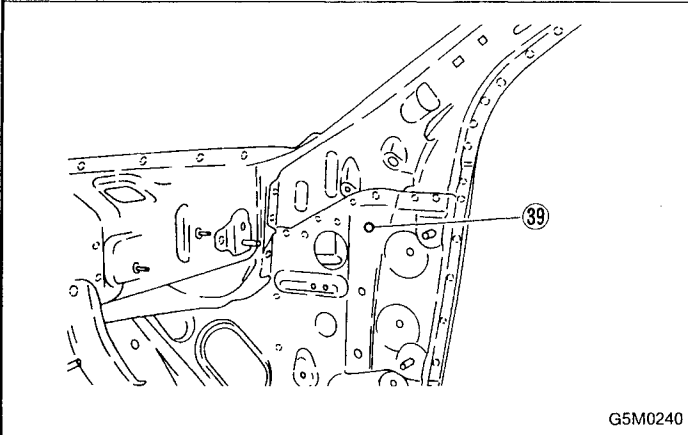
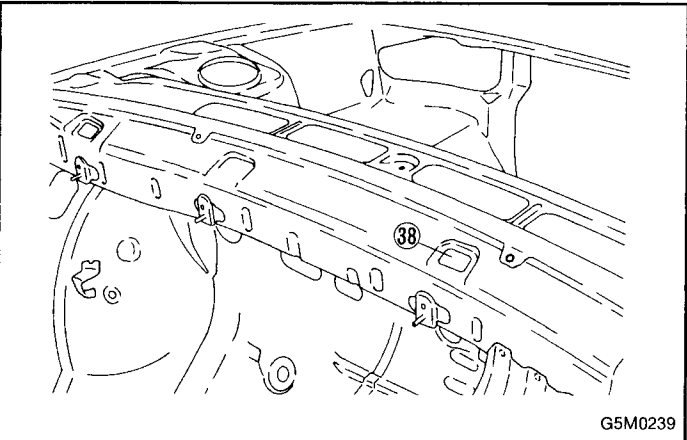
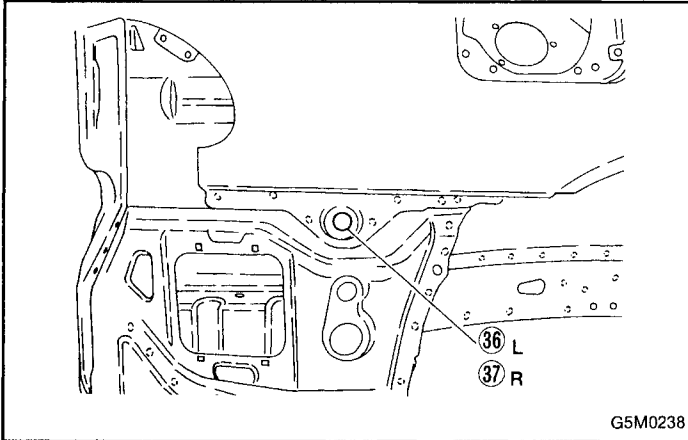

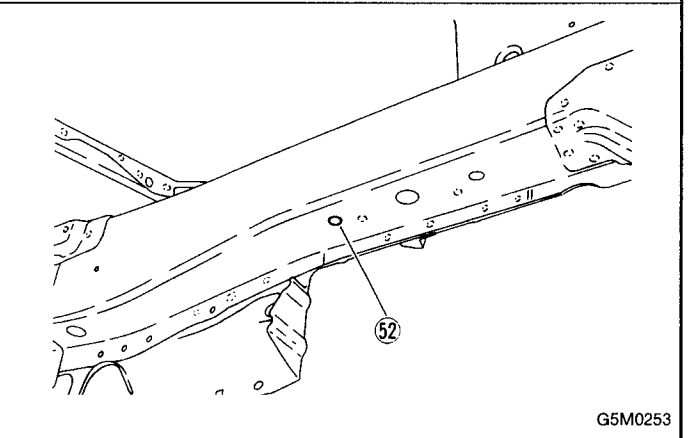
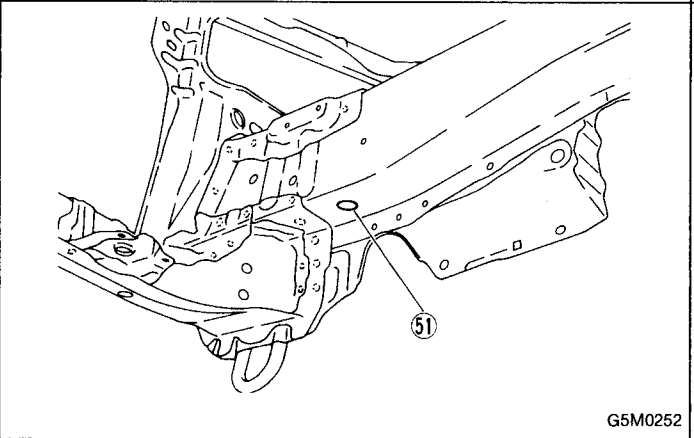
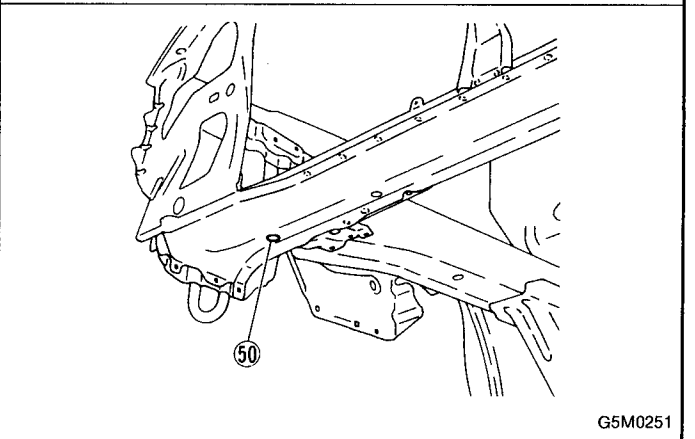
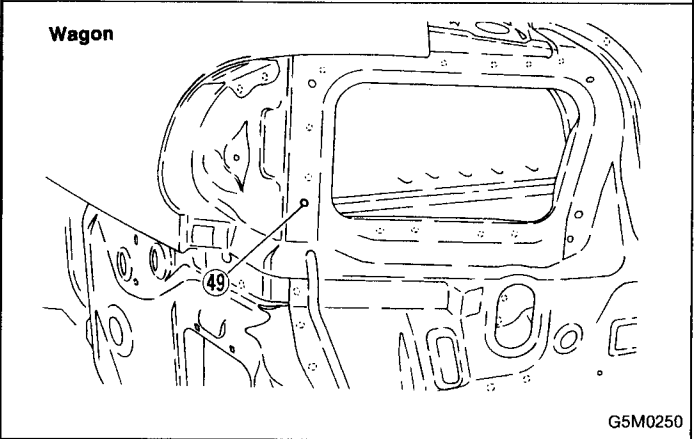
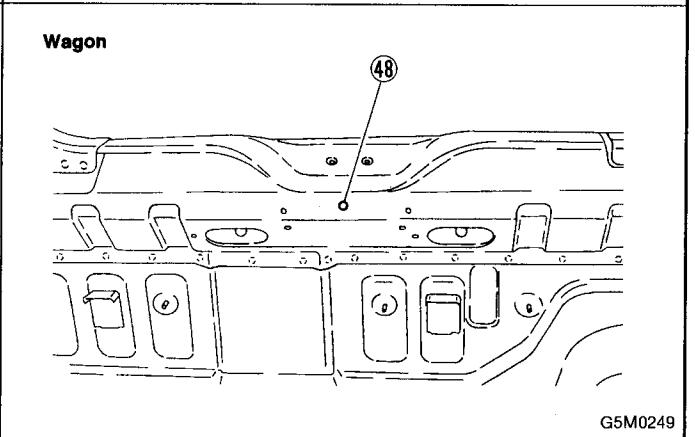
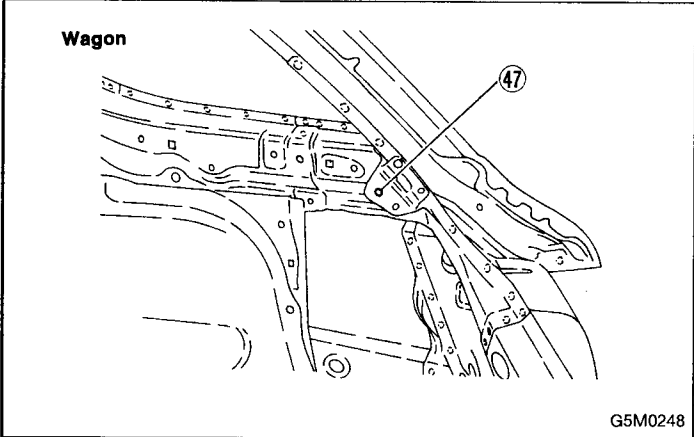
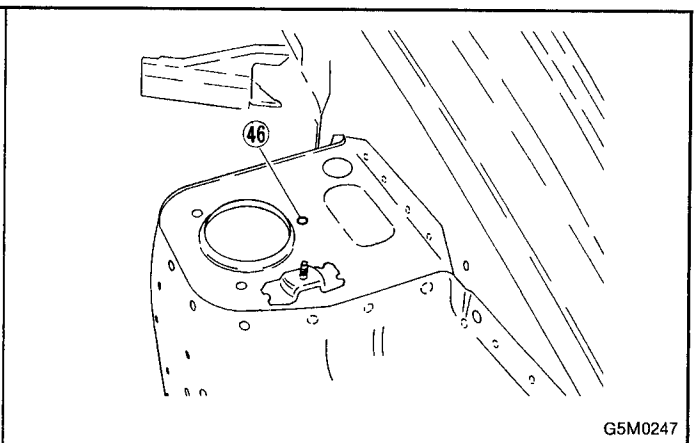
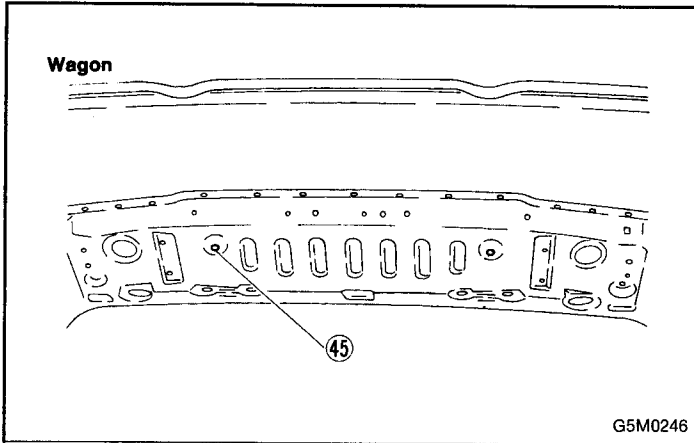

2. Body Datum Points

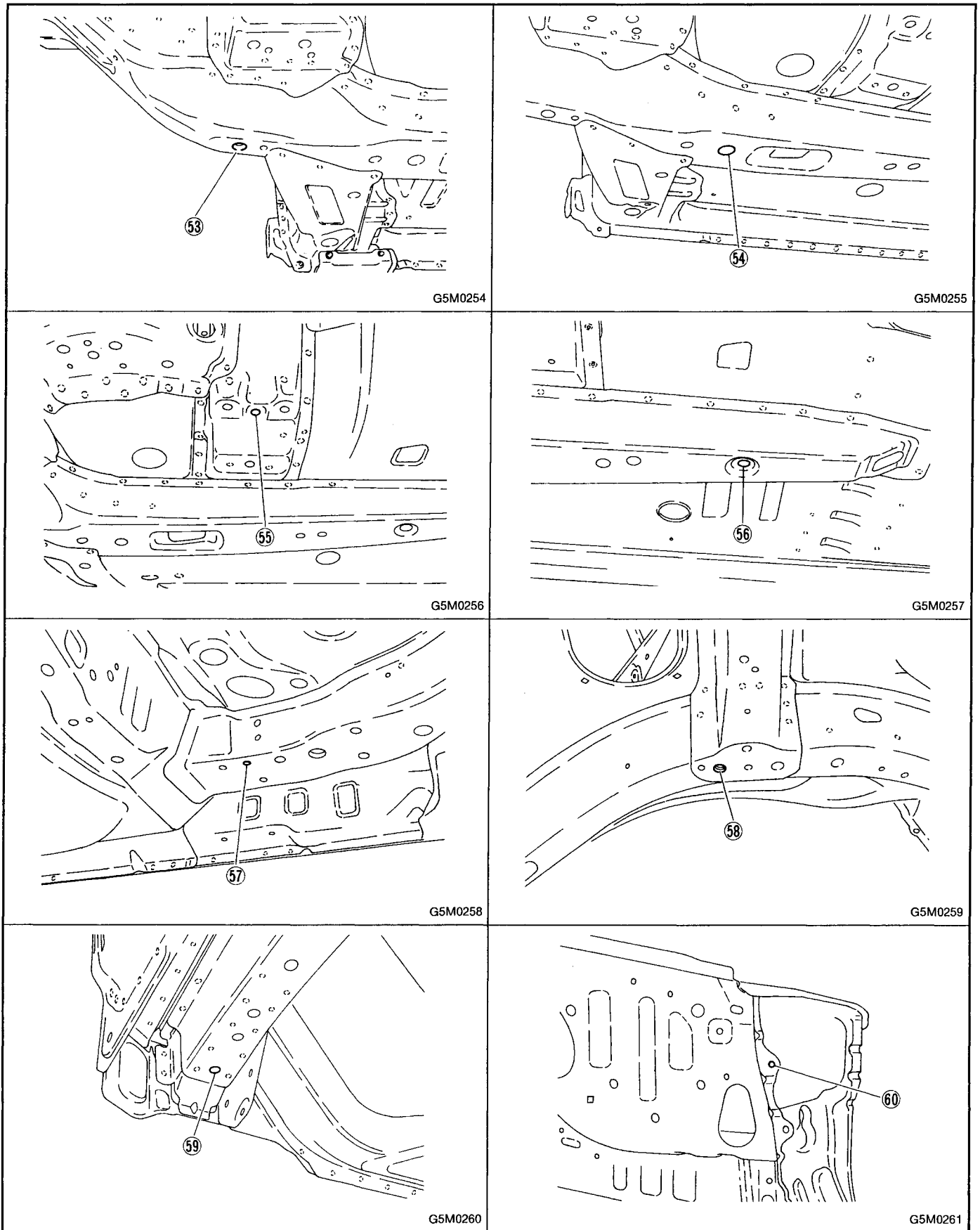

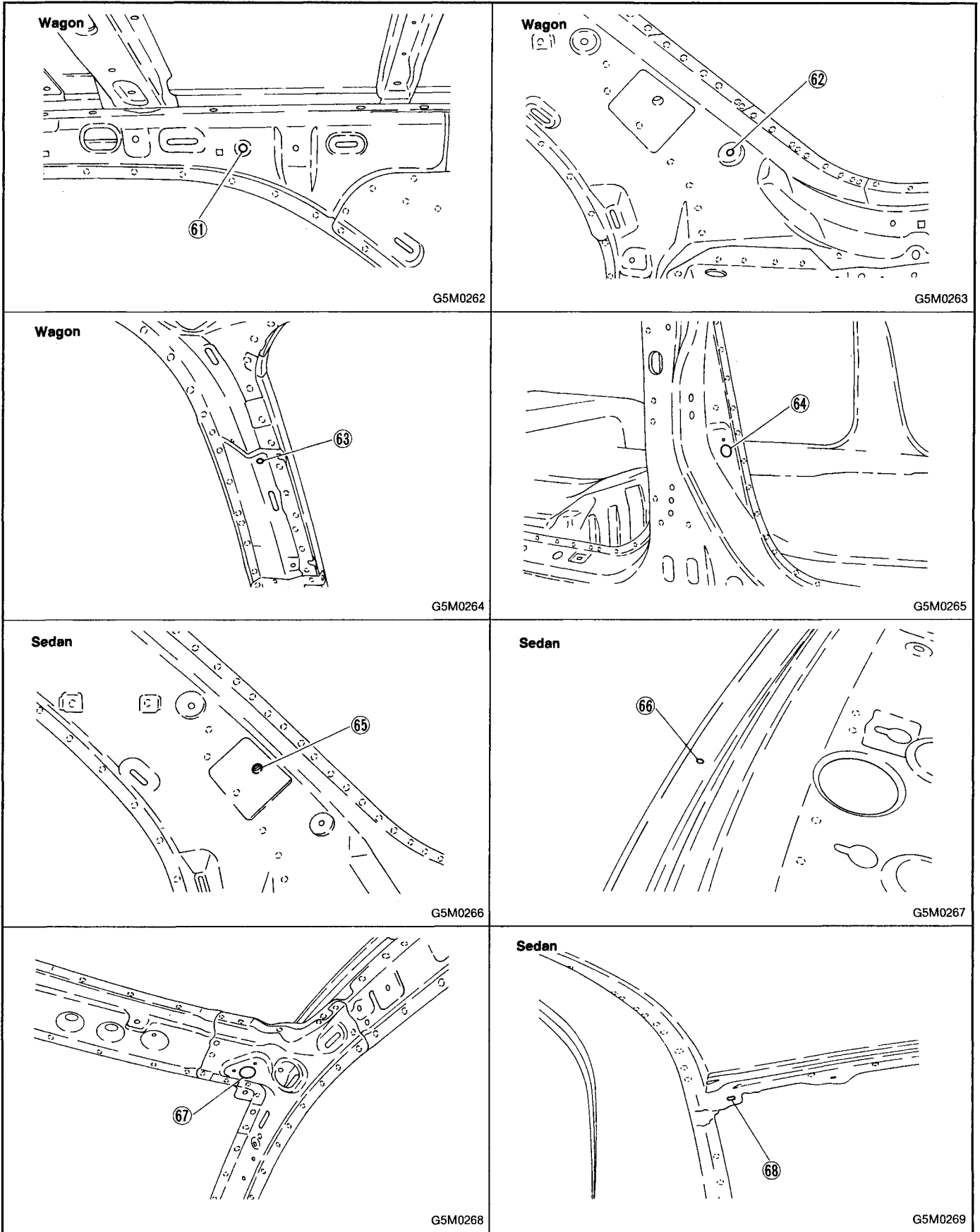

2. Body Datum Points

