

## 16. Rear Quarter Glass

### A: REMOVAL

#### 2. COUPE MODEL

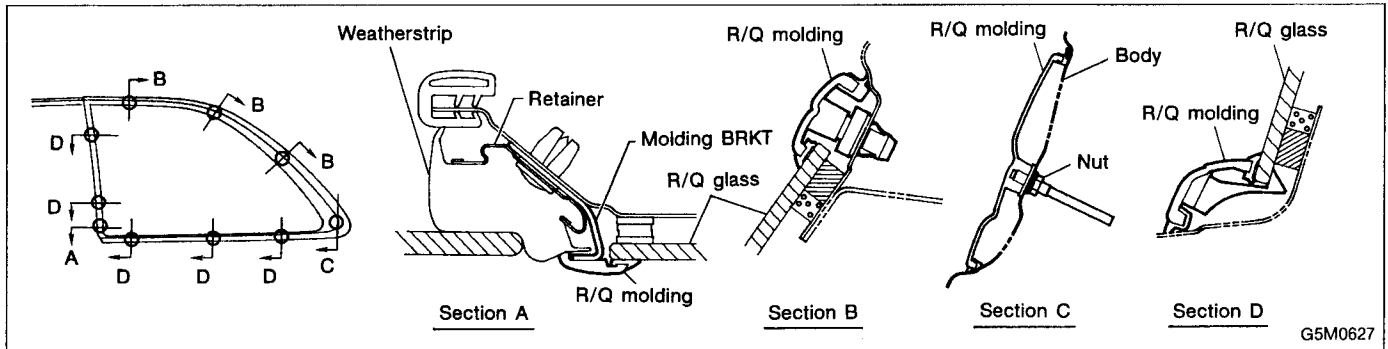

1) Remove rear quarter molding.

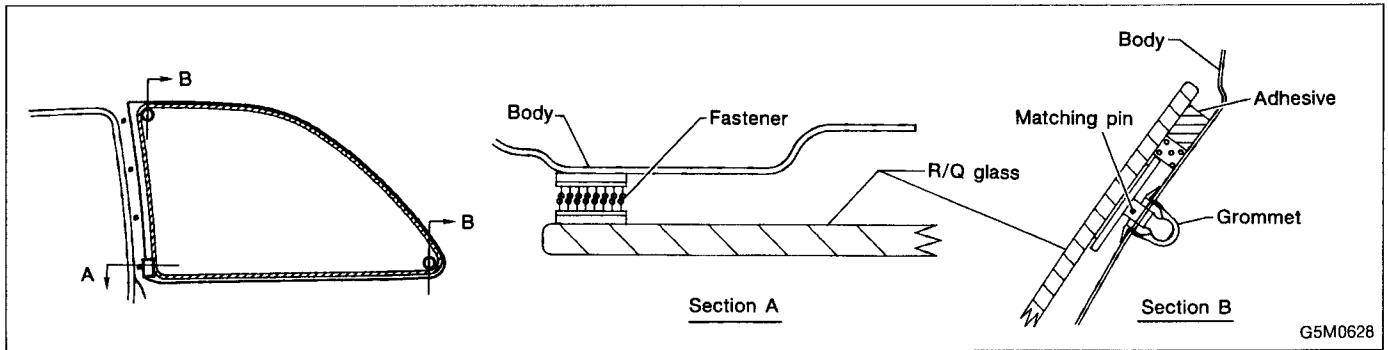

2) Remove glass in same manner as in windshield.

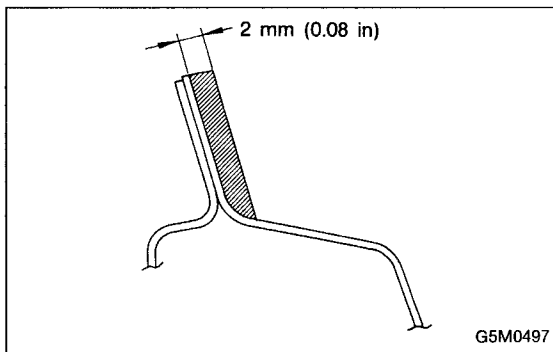

### B: INSTALLATION

#### 2. COUPE MODEL

1) Finish surface of adhesive layer on body.  
Using a putty knife, etc., cut layer of adhesive stick firmly to body and finish it into a smooth surface of about 2 mm (0.08 in) in thickness.

#### CAUTION:

**Be careful not to damage body finish.**

2) Cleaning of body surface

- (1) Remove chips, dirt and dust from body surface.
- (2) Clean body wall surface and upper surface of adhesive layer with a solvent such as alcohol or white gasoline.

3) Cleaning glass

- (1) Remove dirt and dust from surface of glass to be adhered.
- (2) Clean surface of glass to be adhered with alcohol or white gasoline.

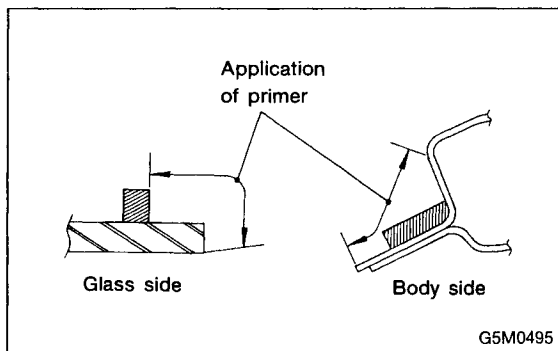

4) Application of primer

- (1) Using a sponge, apply primer to surface of glass to be adhered.
- (2) Apply primer to surface of body to be adhered.

**CAUTION:**

- If primer has dropped on body finish, it is hard to wipe it off. So protect with masking.
- Primer must not project from black frame of glass.
- After applying primer, let it dry spontaneously for about 10 minutes.

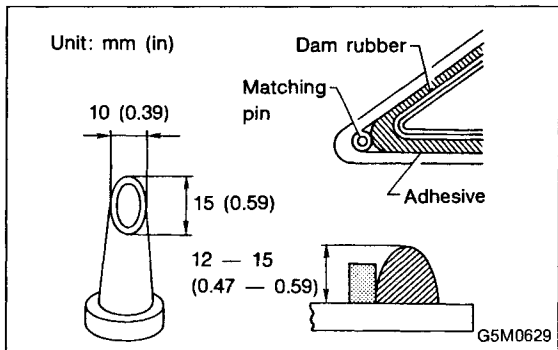

5) Application of adhesive

- (1) Cut nozzle tip as shown in figure.
- (2) Open cartridge and put it into a gun with nozzle attached.
- (3) Apply adhesive uniformly to all sides of adhesion surface while operating gun along glass end face.

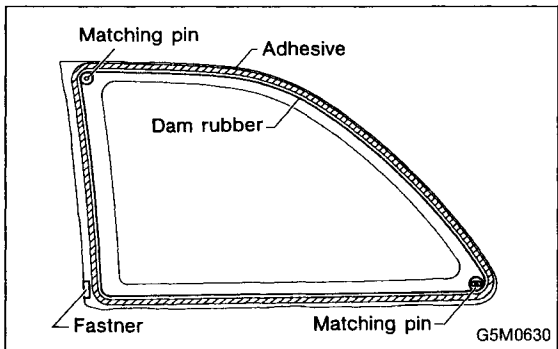

6) Installation of glass

- (1) Hold glass with rubber suction cups.
- (2) Mount glass on body with matching pin aligned.
- (3) Stick them fast by pressing all sides lightly.

7) Water leakage test

After installing glass, test for water leakage after about one hour.

**CAUTION:**

- Move vehicle slowly.
- When opening and closing door, lower door glass and move door gently.
- Do not squirt strong hose stream on vehicle.

8) Spontaneous drying

After completing all operations, leave vehicle alone for 24 hours.

**CAUTION:**

When delivering vehicle to user, tell him that vehicle should not be subjected to heavy shocks for at least three days.