

11. Mud Guard and Arch Protector **AIRBAG**

A: REMOVAL

SUPPLEMENTAL RESTRAINT SYSTEM "AIRBAG"

Airbag system wiring harness is routed near the mud guard.

CAUTION:

- All Airbag system wiring harness and connectors are colored yellow. Do not use electrical test equipment on these circuit.
- Be careful not to damage Airbag system wiring harness when servicing the mud guard.

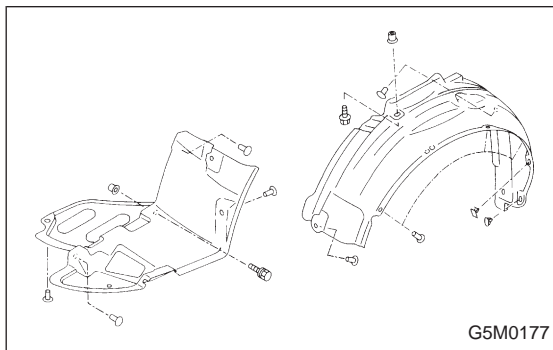

1. MUD GUARD

- 1) Jack-up car to remove tire.
- 2) Remove screws and clips. Move mud guard toward the center of the body and remove mud guard.

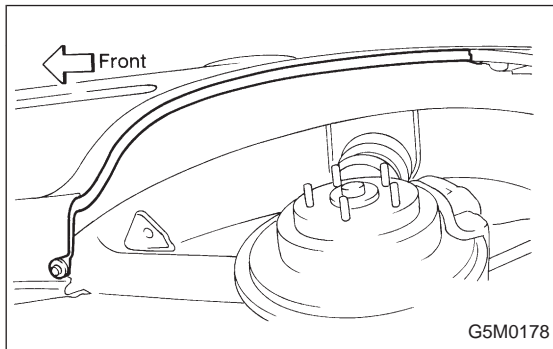

2. REAR ARCH PROTECTOR

- 1) Remove clip and screws.
- 2) Remove arch protectors.

B: INSTALLATION

Installation is in the reverse order of removal.

CAUTION:

Only use new nuts and clips.