

13. Windshield

A: REMOVAL

1. USING WINDSHIELD KNIFE

The following procedure for the front windshield can also be applied to other window glass.

- 1) Remove wiper arm and cowl panel.
- 2) Remove roof molding and front window molding upper.

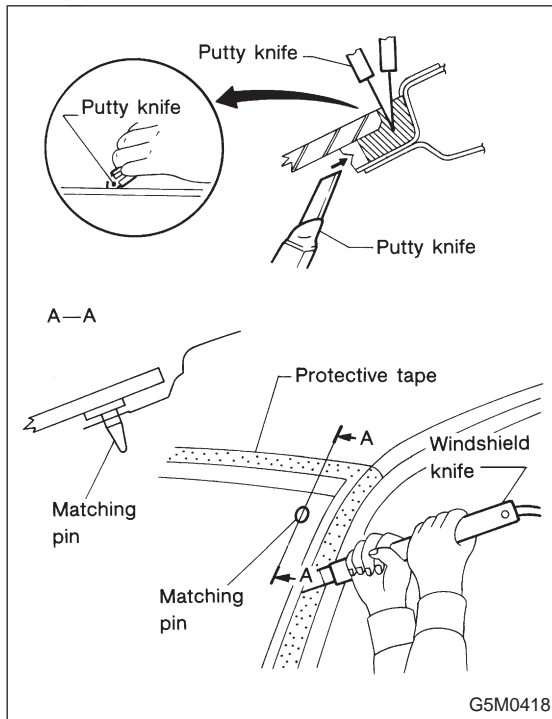

- 3) Remove glass.

- (1) Put protective tape on body to prevent damage.
- (2) Apply soapy water to the surface of the adhesive agent so the knife blade slides smoothly.
- (3) Cut off excess adhesive agent.
- (4) Put windshield knife into layer of adhesive.
- (5) Cut adhesive layer with the windshield knife.

CAUTION:

- Keep knife edge along glass surface and end face.
- When first putting knife into layer of adhesive, select point with wide gap between body and glass.

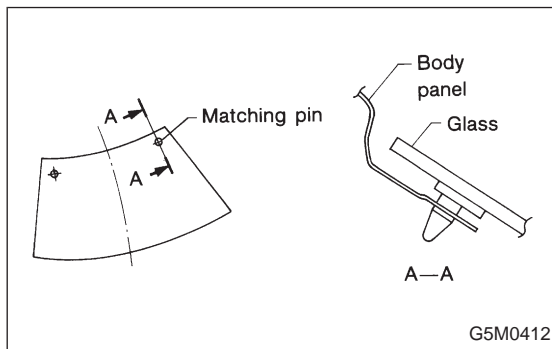

NOTE:

A matching pin is cemented to corners of glass on compartment side.

Use a piano wire when cutting each pin.

2. USING PIANO WIRE

- 1) Remove wiper arm and cowl panel.
- 2) Remove roof molding and front window molding upper.

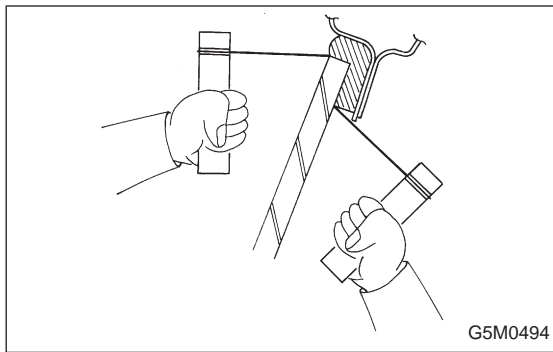

3) Remove glass.

- (1) Put protective tape on body to prevent damage.
- (2) Using drill or putty knife, make through-hole (one place) in adhesive agent.
- (3) Pass piano wire through the hole from inside the compartment, and connect both ends of wire securely to wooden blocks.
- (4) Cut adhesive layer with the wire by pulling it back and forth.

CAUTION:

When making through-hole into adhesive layer and cutting the adhesive, be careful not to damage interior and exterior parts.

B: INSTALLATION

- 1) After cutting layer of adhesive, remove gum rubber remaining on body.

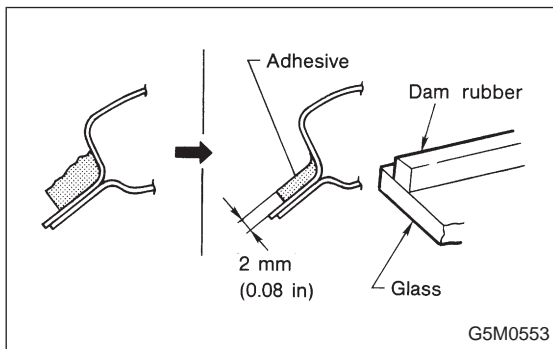

2) Finishing adhesion surface on body side

Using a cutter knife etc., cut layer of adhesive sticking firmly to body, and finish it to a smooth surface of about 2 mm (0.08 in) in thickness.

CAUTION:

Take extra care not to cause damage to body paint.

3) Cleaning body surface

- (1) Thoroughly remove chips, dirt and dust from body surface.
- (2) Clean body wall surface and upper surface of layer of adhesive with a solvent such as alcohol or white gasoline.

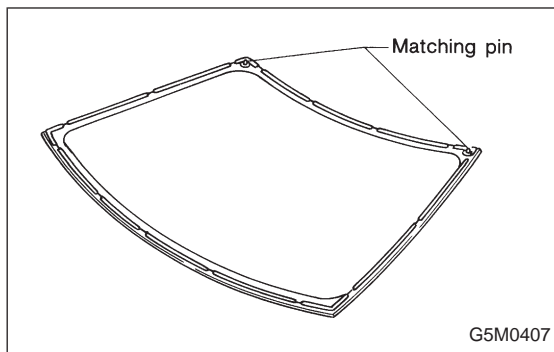

- 4) Positioning glass
- (1) Mount glass on body.
 - (2) Adjust position of glass so that gap between body and glass is uniform on all sides.
 - (3) Put matching pin on body and glass in several places.

- 5) Cleaning glass
- (1) Dismount glass from body.
 - (2) Clean surface of glass to be adhered with alcohol or white gasoline.

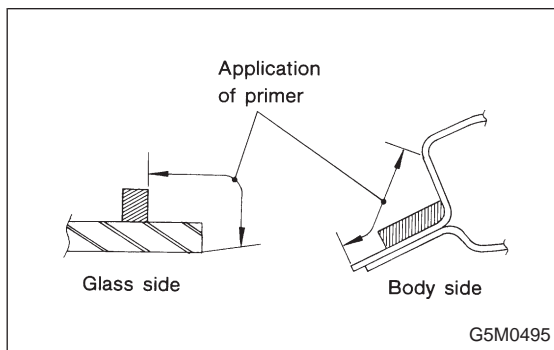

- 6) Application of primer
- (1) Using a sponge, apply primer to part of glass to be adhered.
 - (2) Apply primer to part of body to be adhered.

CAUTION:

- Primer is hard to wipe off of body paint, instrument panel, inner trim, etc. So put masking around these areas for protection.
- After application, let 1st primer dry spontaneously for about 10 minutes.
- Do not touch primer-coated surface under any circumstances.

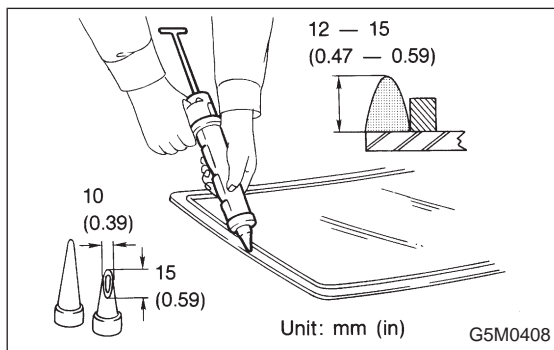

- 7) Application of adhesive
- (1) Cut nozzle tip of cartridge as shown in figure.
 - (2) Open cartridge and put it into a gun with nozzle attached.
 - (3) Apply adhesive uniformly to all sides of adhesion surface while operating gun along glass end face.

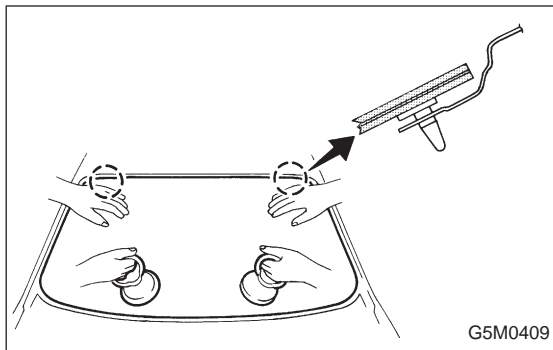

8) Installation of glass

- (1) Hold glass with rubber suction cups.
- (2) Mount glass on body with matching pin aligned.
- (3) Stick them fast by pressing all sides lightly.

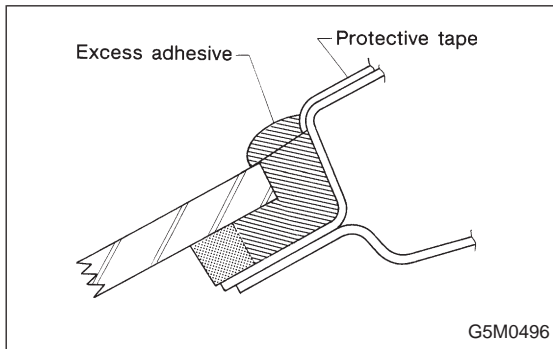

9) Installation of molding

- (1) Remove adhesive overflowing from outside of glass until it becomes level with outer height of glass. Then, add adhesive to portions that need it, and clean with alcohol or white gasoline.
- (2) Firstly, press-fit front window molding upper and lastly, roof molding.

CAUTION:

Do not open and close door after moldings have been installed. When opening and closing door for unavoidable reason, lower door glass and gently move door.

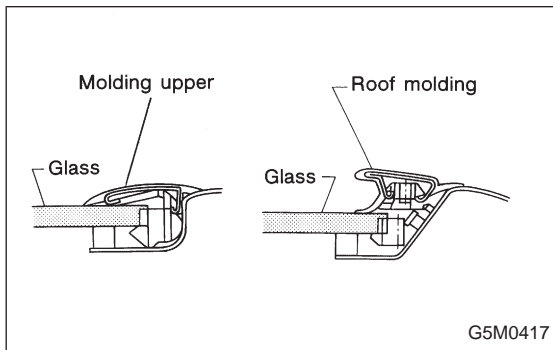

10) Water leakage test

Test for water leakage about one hour after installation.

CAUTION:

- Move vehicle very gently.
- Do not squirt strong hose stream on vehicle.

11) Spontaneous drying

After completing all operations, leave vehicle alone for 24 hours.

CAUTION:

When delivering vehicle to user, tell him that vehicle should not be subjected to heavy shocks for at least three days.

12) Install cowl panel and wiper arm.