

# 18. Front Door Glass Adjustment

## A: ADJUSTMENT

### 1. SEDAN AND WAGON MODEL

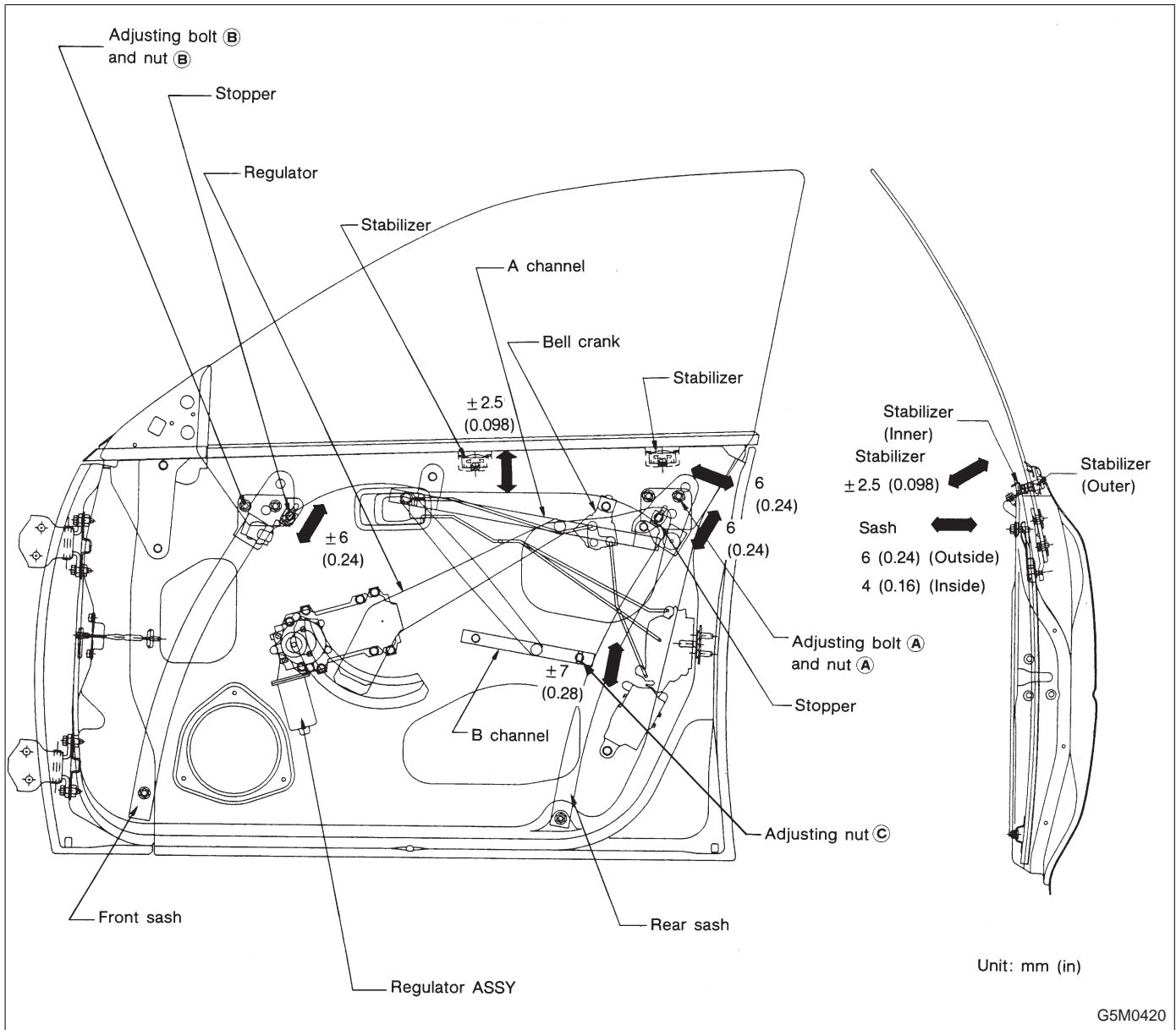

2. COUPE MODEL

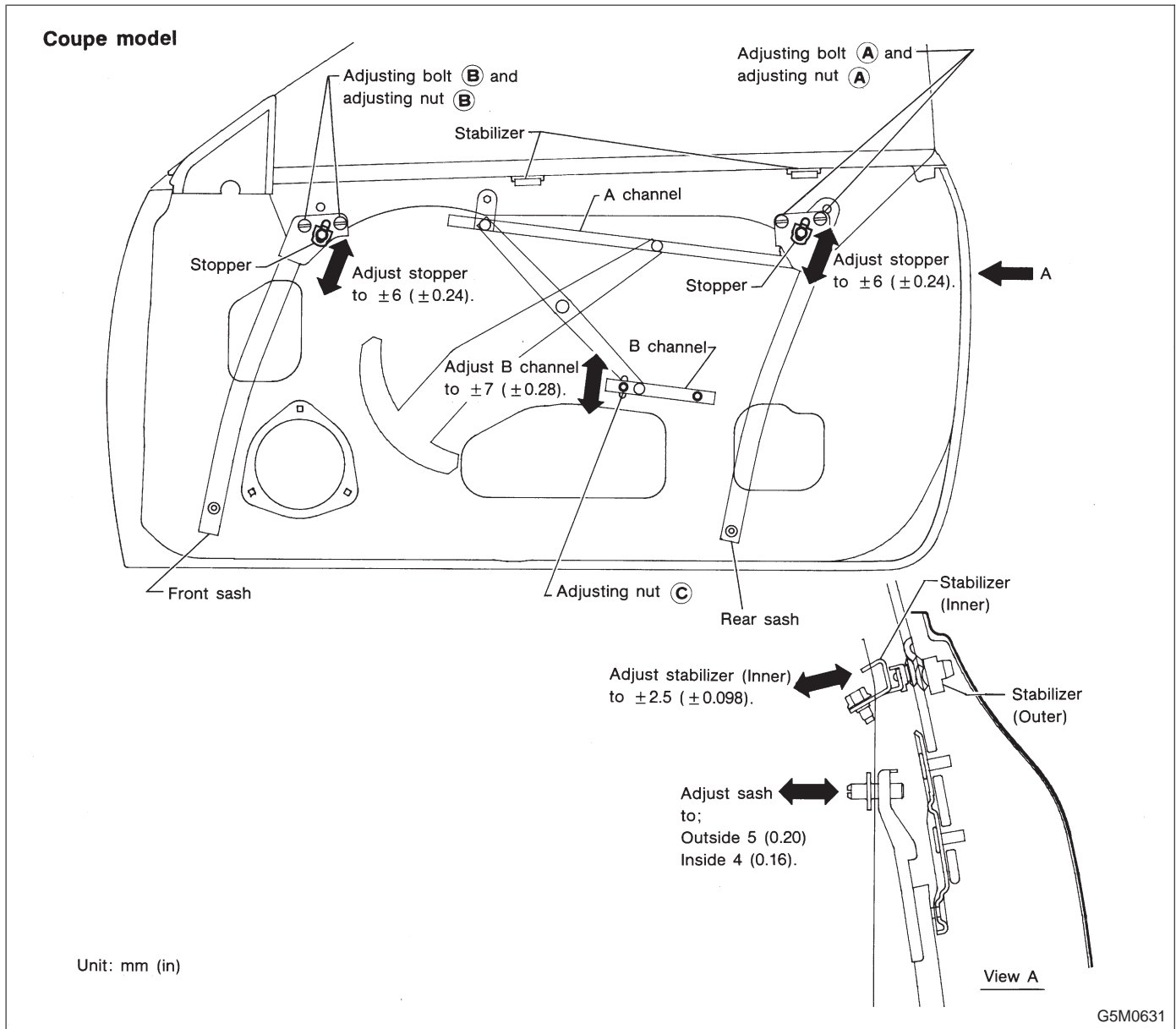

G5M0631

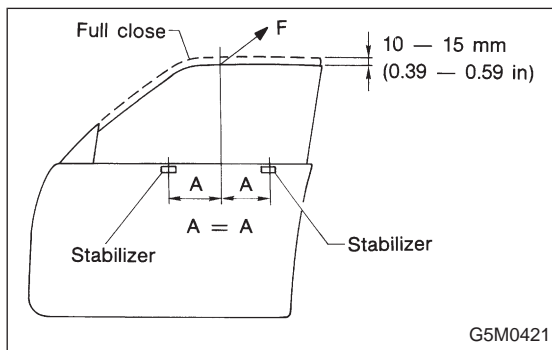

G5M0421

3. DOOR GLASS FIT ADJUSTMENT

Before adjusting door glass alignment, ensure adjusting bolts for stabilizers, upper stoppers and sashes are loose and glass is raised so that it is in contact with upper and side weatherstrip.

- 1) Temporarily tighten one of the two rear sash adjusting bolts, at midpoint of oblong hole on inner panel.
- 2) Temporarily tighten regulator B channel at a position slightly lower than midpoint of oblong hole on inner panel.

3) Lower door glass 10 to 15 mm (0.39 to 0.59 in) from fully closed position. While applying outward pressure (load) to upper edge of glass above midpoint of two outer stabilizers, press inner stabilizer until it just touches the glass, then secure it.

**Load: F**

**Front door glass 39 — 49 N (4 — 5 kg, 9 — 11 lb)**

**Rear door glass 39 — 49 N (4 — 5 kg, 9 — 11 lb)**

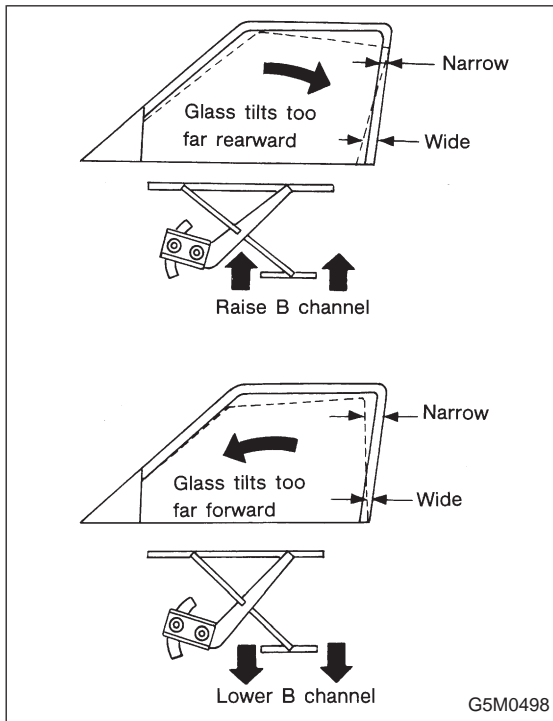

**4. REMEDY FOR UNEQUAL DIMENSIONS, BETWEEN UPPER, LOWER AND CENTER PILLAR SIDES (SEDAN AND WAGON MODEL)**

- 1) Close front door and raise door glass.
- 2) Make sure of unequal dimensions.

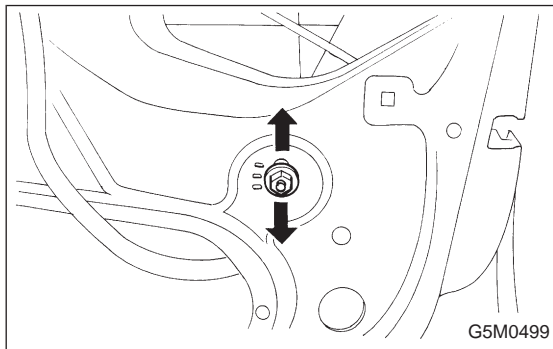

3) If glass tilts to far rearward, loosen adjusting nut © and adjust glass to be parallel with center pillar, then after adjustment, tighten adjusting nut ©.

18. Front Door Glass Adjustment

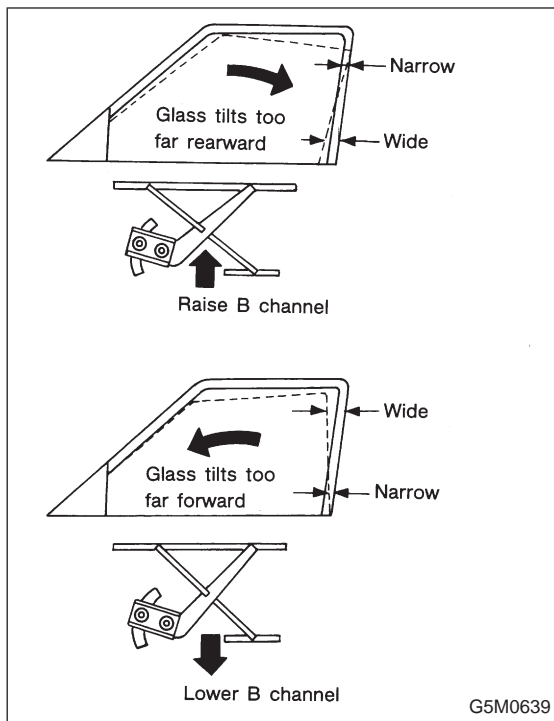

**5. REMEDY FOR UNEQUAL DIMENSIONS, BETWEEN UPPER, LOWER AND CENTER PILLAR SIDES (COUPE MODEL)**

- 1) Close front door and raise door glass.
- 2) Make sure of unequal dimensions.

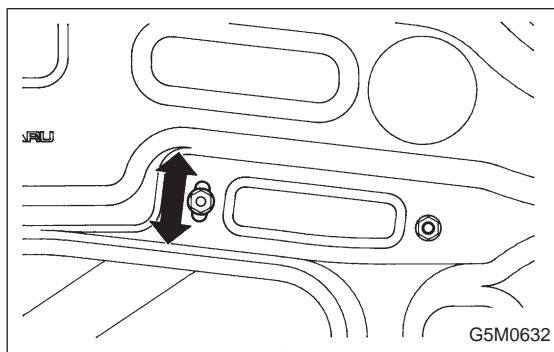

- 3) If glass tilts to far rearward, loosen adjusting nut ③ and adjust glass to be parallel with center pillar, then after adjustment, tighten adjusting nut ③.

**Tightening torque:**

**7.4±2.0 N·m (0.75±0.2 kg-m, 5.4±1.4 ft-lb)**

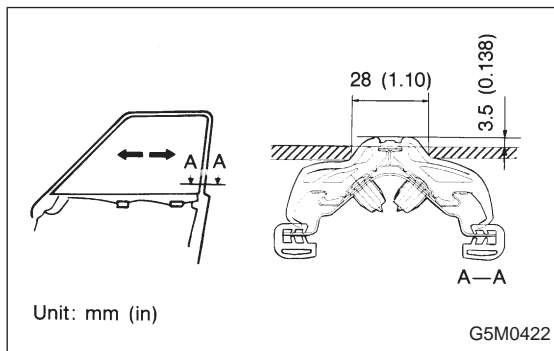

**6. REMEDY FOR IMPROPER GLASS TO CENTER PILLAR CLEARANCE (SEDAN AND WAGON MODEL)**

- 1) Close front door and raise door glass.
- 2) Make sure of improper clearance.

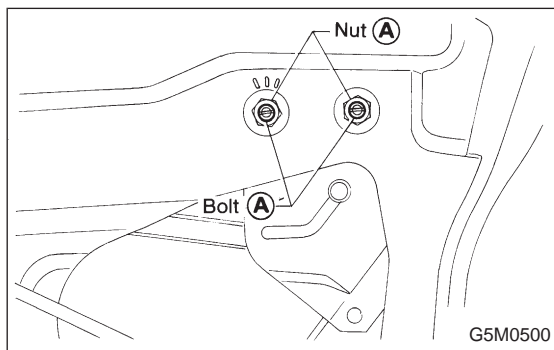

- 3) If clearance is improper, loosen adjusting nut ①, bolt ② and adjust glass to center pillar.

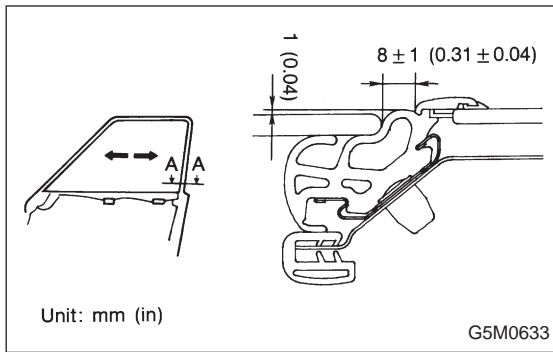

**7. REMEDY FOR IMPROPER GLASS TO CENTER PILLAR CLEARANCE (COUPE MODEL)**

- 1) Close front door and raise door glass.
- 2) Make sure of improper clearance.

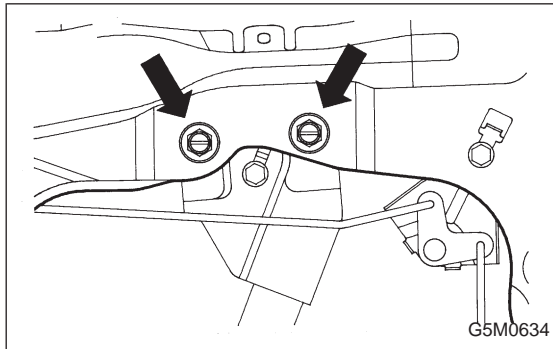

- 3) If clearance is improper, loosen adjusting nut (A), bolt (A) and adjust glass to center pillar.

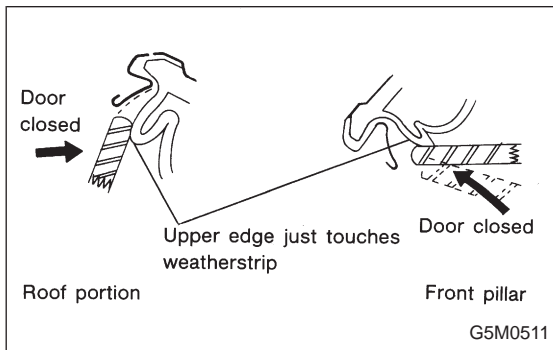

**8. REMEDY FOR IMPROPER UPPER STOP POINT OF DOOR GLASS**

- 1) Loosen front and rear sash stoppers.
- 2) Increase the upward travel of window glass up to the position where upper edge just touches weatherstrip surface with door closed.
- 3) After adjustment, temporarily tighten stoppers.

NOTE:

Make sure that each glass stopper is touched.

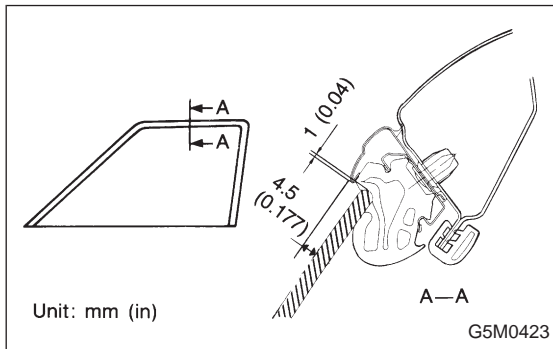

**9. REMEDY FOR INCORRECT CONTACT OF DOOR GLASS TO WEATHERSTRIP (SEDAN AND WAGON MODEL)**

- 1) Close front door and raise door glass.
- 2) If clearance is below specifications, loosen bolt (A) and bolt (B).
- 3) If clearance is over specifications, tighten bolt (A) and bolt (B).

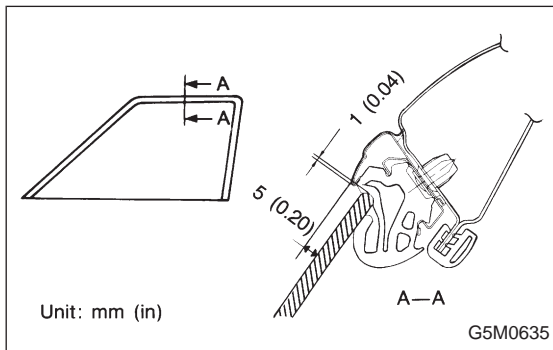

**10. REMEDY FOR INCORRECT CONTACT OF DOOR GLASS TO WEATHERSTRIP (COUPE MODEL)**

- 1) Close front door and raise door glass.
- 2) If clearance is below specifications, loosen bolt (A) and bolt (B).
- 3) If clearance is over specifications, tighten bolt (A) and bolt (B).

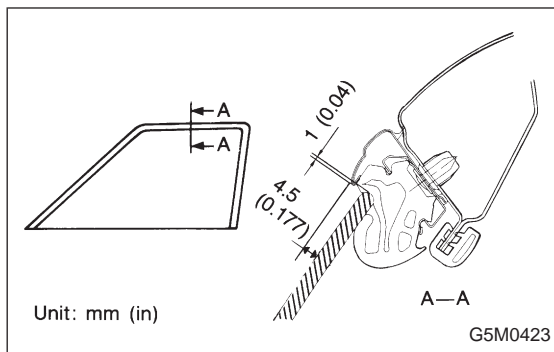

### 11. FIT ADJUSTMENT (SEDAN AND WAGON MODEL)

Door glass fit is adjusted by displacing the glass front edge with a stabilizer.

#### NOTE:

Before adjusting glass fit, visually check to determine relative adjusting positions of retainer and molding (on roof side) and glass surface.

1) Alternately adjust two rear sash adjusting bolts (A) until dimensions (indicated in figure) are obtained.

#### CAUTION:

**Do not loosen two adjusting nuts (A) at the same time, as this moves sash fore and aft, creating unequal glass-to-sash clearance. During adjustment, loosen only one nut and keep the other tightened.**

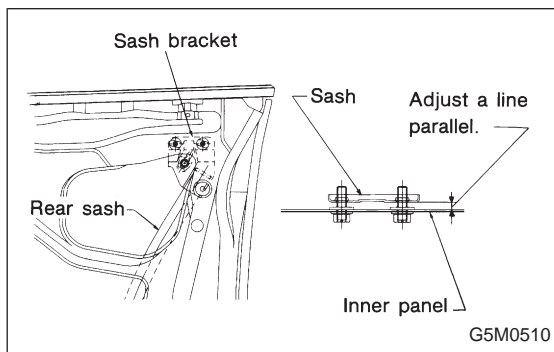

#### NOTE:

Always adjust two rear sash adjusting bolts (A) by the same amount. Do not adjust the adjusting bolts with sash bracket inclined toward inner panel, as this increases effort required to operate regulator.

2) Adjust front sash fit using rear sash adjustment procedure outlined above as a guide. Two adjusting bolts must be adjusted by the same amount.

#### NOTE:

Front and rear sash adjustment procedures are basically the same; however, the amount of adjustment is not always the same due to alignment dispersion of individual doors. Adjust front and rear sash fit, as equally as possible. Otherwise, effort required to operate regulator may increase.

3) After adjusting front sash-to-glass fit, secure front sash.

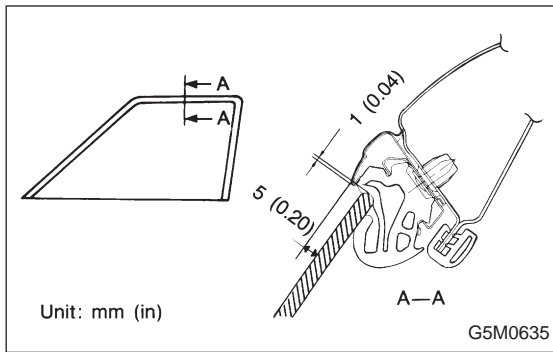

**12. FIT ADJUSTMENT (COUPE MODEL)**

Door glass fit is adjusted by displacing the glass front edge with a stabilizer.

**NOTE:**

Before adjusting glass fit, visually check to determine relative adjusting positions of retainer and molding (on roof side) and glass surface.

1) Alternately adjust two rear sash adjusting bolts (A) until dimensions (indicated in figure) are obtained.

**CAUTION:**

**Do not loosen two adjusting nuts (A) at the same time, as this moves sash fore and aft, creating unequal glass-to-sash clearance. During adjustment, loosen only one nut and keep the other tightened.**

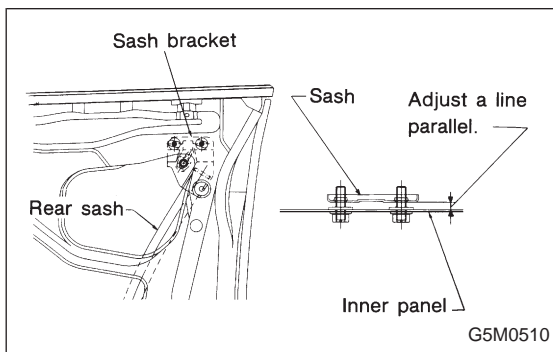

**NOTE:**

Always adjust two rear sash adjusting bolts (A) by the same amount. Do not adjust the adjusting bolts with sash bracket inclined toward inner panel, as this increases effort required to operate regulator.

2) Adjust front sash fit using rear sash adjustment procedure outlined above as a guide. Two adjusting bolts must be adjusted by the same amount.

**NOTE:**

- Front and rear sash adjustment procedures are basically the same; however, the amount of adjustment is not always the same due to alignment dispersion of individual doors.

- Adjust front and rear sash fit, as equally as possible. Otherwise, effort required to operate regulator may increase.

3) After adjusting front sash-to-glass fit, secure front sash.

**B: INSPECTION****1. SEDAN AND WAGON MODEL**

1) Close front door and make sure of all clearances.

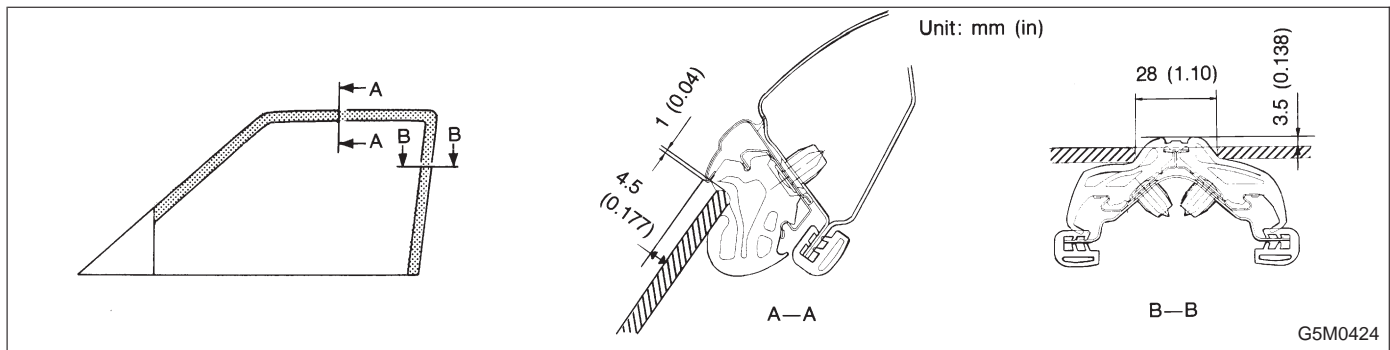

2) If any clearance is not correct, adjust affected parts. Recheck all clearances.

**CAUTION:**

- Repeatedly adjust parts until all clearances are correct.
- After clearance adjustment, make sure that all adjusting bolts and nuts are tightened.

**2. COUPE MODEL**

1) Close front door and make sure of all clearances.

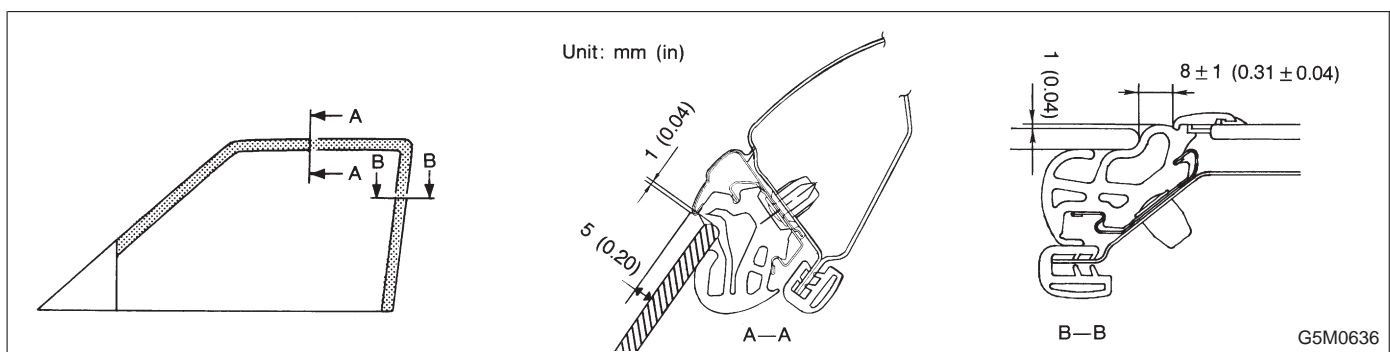

2) If any clearance is not correct, adjust affected parts. Recheck all clearances.

**CAUTION:**

- Repeatedly adjust parts until all clearances are correct.
- After clearance adjustment, make sure that all adjusting bolts and nuts are tightened.