

6. Diagnostics Chart with Trouble Code

Trouble code	Contents of diagnosis		Page
NONE: A [Warning light OFF]	Trouble in warning light drive circuit (Warning light is not on for 1.5 seconds after ignition switch is on.)		12
NONE: B [Warning light ON] or [Abnormal trouble code output]	Trouble in warning light drive circuit		14
11	Start code: ● Trouble code is shown after start code. ● Only start code is shown in normal condition.		—
21	Faulty A.B.S. sensor (Open circuit or input voltage excessive)	Front right wheel sensor	16
23		Front left wheel sensor	16
25		Rear right wheel sensor	16
27		Rear left wheel sensor	16
22	Faulty A.B.S. sensor (When there is no open circuit or speed signal input.)	Front right wheel sensor	20
24		Front left wheel sensor	20
26		Rear right wheel sensor	20
28		Rear left wheel sensor	20
29	Faulty tone wheel, etc.		24
31	Faulty solenoid valve circuit(s) in hydraulic unit	Front right wheel control	28
33		Front left wheel control	28
39		Rear wheels control	28
41	Faulty A.B.S. control module		30
42	Source voltage is low.		30
51	Faulty valve relay		32
52	Faulty hydraulic motor and/or motor relay		36
54	Faulty stop light circuit		39
56	Use of improper A.B.S. control module specification, or faulty G sensor		40

**A: TROUBLE CODE (NONE: A)
— TROUBLE IN WARNING LIGHT DRIVE
CIRCUIT —**

DIAGNOSIS:

- Faulty A.B.S. warning light
- Faulty harness connector
- Faulty A.B.S. control module
- Faulty valve relay

TROUBLE SYMPTOM:

- Warning light does not illuminate.
- Impossible to read trouble code.

NOTE:

When ignition key is on, warning light should turn off after 1.5 seconds if system is normal.

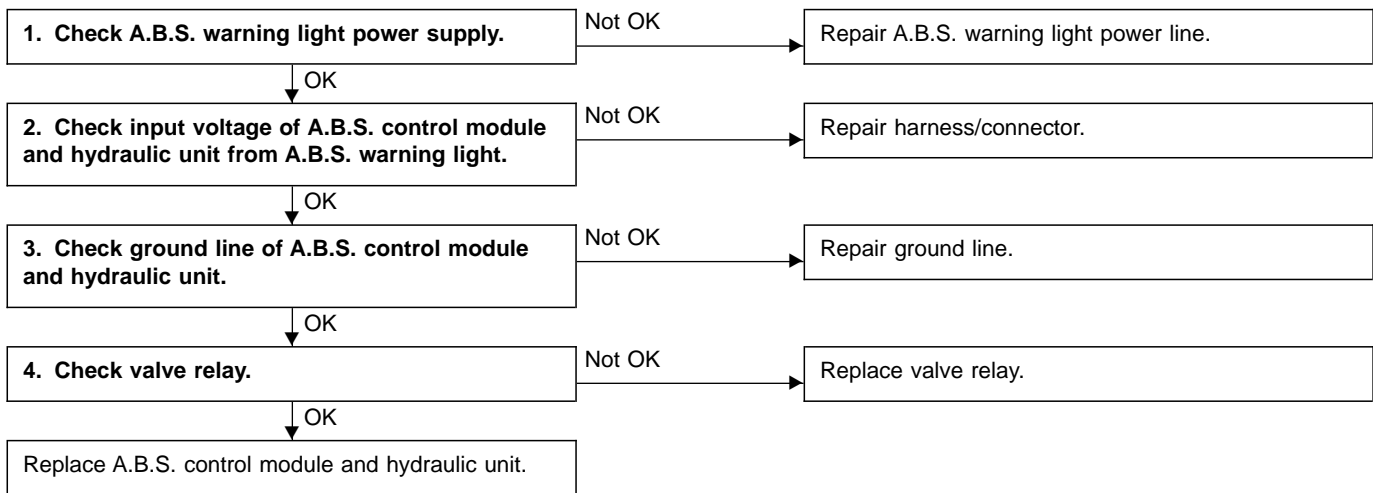

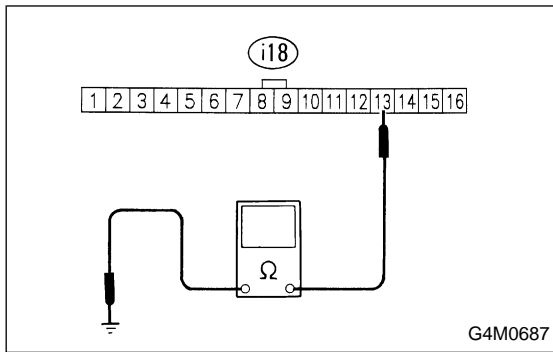

1. CHECK A.B.S. WARNING LIGHT POWER SUPPLY.

- 1) Turn ignition switch OFF.
- 2) Disconnect combination meter.
- 3) Check A.B.S. warning light valve.
- 4) Turn ignition switch ON.
- 5) Measure voltage between combination meter connector and body.

Connector & terminal / Specified voltage:
(i18) No. 13 — Body / 10 — 12 V

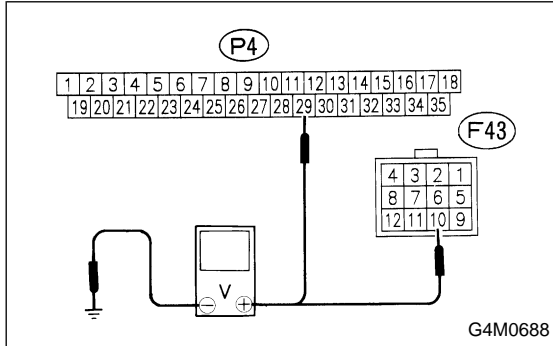

2. CHECK INPUT VOLTAGE OF A.B.S. CONTROL MODULE AND HYDRAULIC UNIT FROM A.B.S. WARNING LIGHT.

- 1) Turn ignition switch OFF and remove combination meter.
- 2) Disconnect connector from A.B.S. control module and hydraulic unit.
- 3) Turn ignition switch ON.
- 4) Measure voltage between A.B.S. control module and body, and between hydraulic unit and body.

Connector & terminal / Specified voltage:
(P4) No. 29 — body / 10 — 12 V
(F43) No. 10 — body / 10 — 12 V

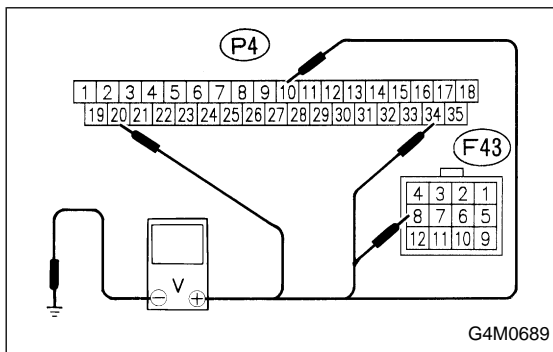

3. CHECK GROUND LINE OF A.B.S. CONTROL MODULE AND HYDRAULIC UNIT.

- 1) Measure resistance between A.B.S. control module and body, and between hydraulic unit and body.

Connector & terminal / Specified resistance:
(P4) No. 10 — body / 0 Ω
(P4) No. 20 — body / 0 Ω
(P4) No. 34 — body / 0 Ω
(F43) No. 8 — body / 0 Ω

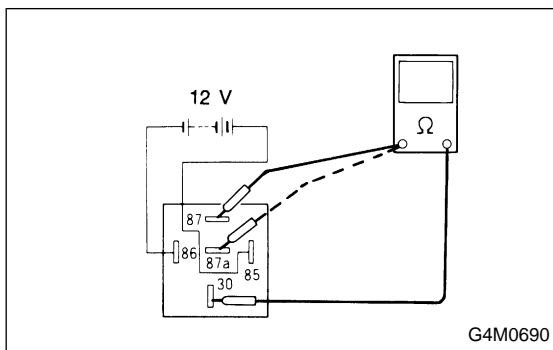

4. CHECK VALVE RELAY.

- 1) Remove valve relay.
- 2) Attach circuit tester probes to terminals, as shown in figure.
- 3) Measure resistance between respective terminals.

Terminal / Specified resistance:
No. 87 — 30 / 0 Ω (when 12 volts applied.)
No. 87 — 30 / 1 MΩ (when no voltage is applied.)
No. 87a — 30 / 1 MΩ (when 12 volts applied.)
No. 87a — 30 / 0 Ω (when no voltage is applied.)

**B: TROUBLE CODE (NONE: B)
— TROUBLE IN WARNING LIGHT DRIVE
CIRCUIT —**

DIAGNOSIS:

- Faulty harness
- Faulty A.B.S. control module

TROUBLE SYMPTOM:

- Warning light remains on.
- Impossible to read trouble code.

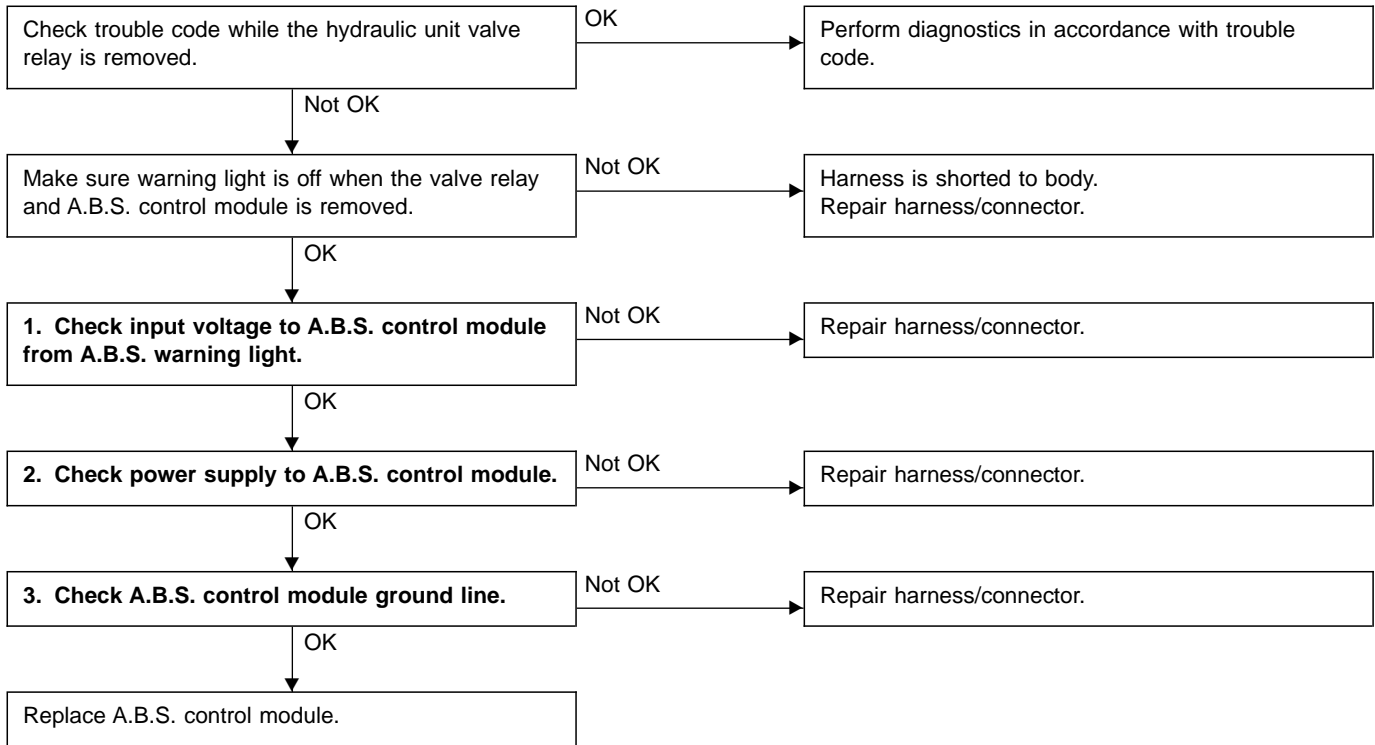

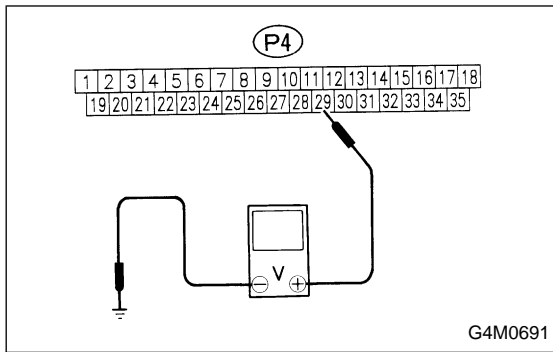

1. CHECK INPUT VOLTAGE TO A.B.S. CONTROL MODULE FROM A.B.S. WARNING LIGHT.

- 1) Turn ignition switch OFF.
- 2) Disconnect connector from A.B.S. control module.
- 3) Turn ignition switch ON.
- 4) Measure voltage between A.B.S. control module connector and body.

Connector & terminal / Specified voltage:
(P4) No. 29 — Body / 10 — 12 V

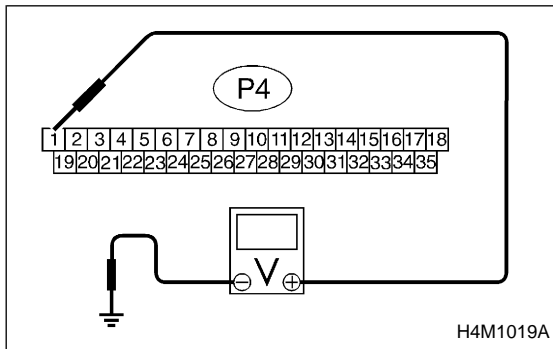

2. CHECK POWER SUPPLY TO A.B.S. CONTROL MODULE.

- 1) Turn ignition switch ON.
- 2) Measure voltage between A.B.S. control module connector and body.

Connector & terminal / Specified voltage:
(P4) No. 1 — Body / 10 — 12 V

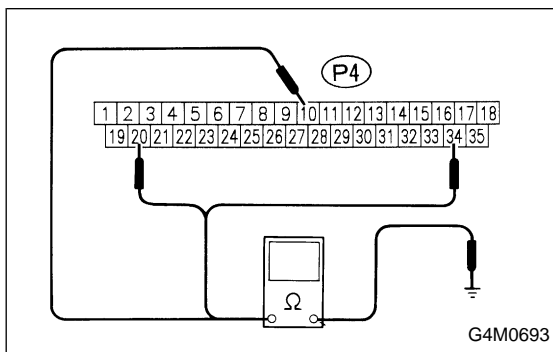

3. CHECK A.B.S. CONTROL MODULE GROUND LINE.

- 1) Measure resistance between A.B.S. control module and body.

Connector & terminal / Specified resistance:
(P4) No. 10 — body / 0 Ω
(P4) No. 20 — body / 0 Ω
(P4) No. 34 — body / 0 Ω

**C: TROUBLE CODE 21, 23, 25 AND 27
— FAULTY A.B.S. SENSOR (OPEN CIRCUIT
OR INPUT VOLTAGE EXCESSIVE) —**

DIAGNOSIS:

- Faulty A.B.S. sensor
- Faulty harness
- Faulty A.B.S. control module

TROUBLE SYMPTOM:

- A.B.S. does not operate.

NOTE:

Trouble codes 21, 23, 25, and 27 will not be stored while vehicle is stationary and can't specify problem location. Drive vehicle first, perform diagnosis and read trouble code.

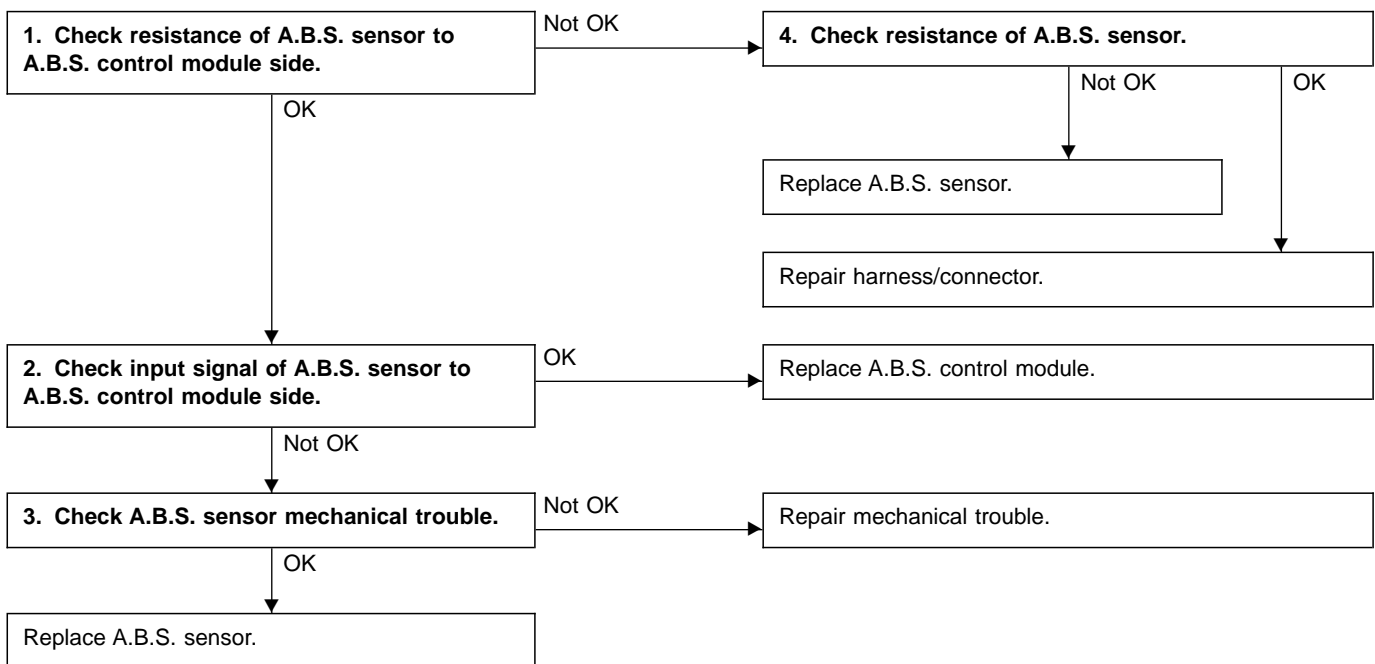

NOTE:

When checking A.B.S. sensor, carefully bend or swing connector and harness to check for improper contacts or open circuits.

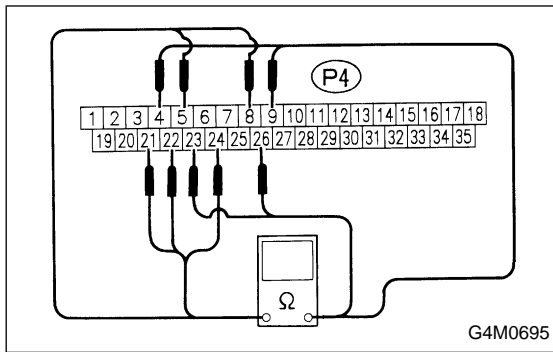

1. CHECK RESISTANCE OF A.B.S. SENSOR TO A.B.S. CONTROL MODULE SIDE.

- 1) Turn ignition switch OFF.
- 2) Disconnect connector from A.B.S. control module.
- 3) Measure resistance between A.B.S. control module connector terminals.

TROUBLE CODE / Connector & terminal:

- 21 / (P4) No. 23 — No. 21
- 23 / (P4) No. 22 — No. 4: AWD
- (P4) No. 5 — No. 4: FWD
- 25 / (P4) No. 24 — No. 26
- 27 / (P4) No. 8 — No. 9
- Specified resistance: 0.8 — 1.3 kΩ**

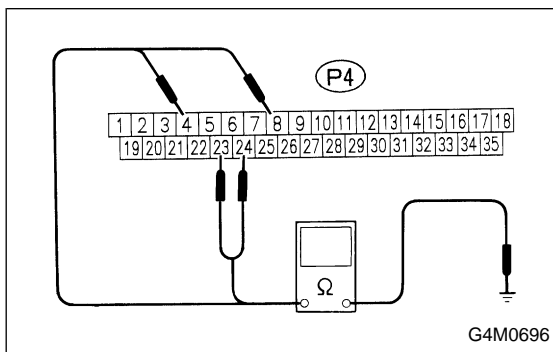

- 4) Measure resistance between A.B.S. control module connector and body.

TROUBLE CODE / Connector & terminal:

- 21 / (P4) No. 23 — body
- 23 / (P4) No. 4 — body
- 25 / (P4) No. 24 — body
- 27 / (P4) No. 8 — body
- Specified resistance: 1 MΩ, min.**

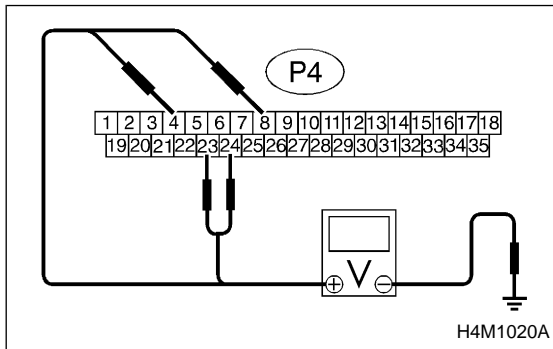

- 5) Turn ignition switch ON.
- 6) Measure voltage between A.B.S. control module connector and body.

TROUBLE CODE / Connector & terminal:

- 21 / (P4) No. 23 — body
- 23 / (P4) No. 4 — body
- 25 / (P4) No. 24 — body
- 27 / (P4) No. 8 — body
- Specified voltage: 0 V**

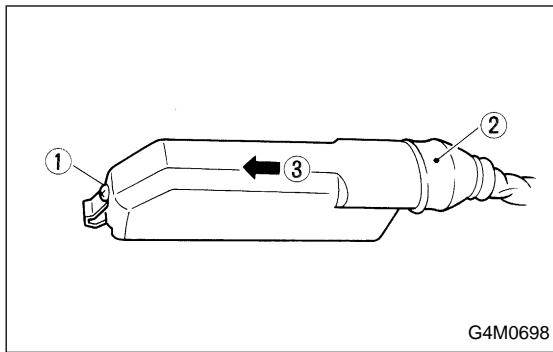

G4M0698

2. CHECK INPUT SIGNAL OF A.B.S. SENSOR TO A.B.S. CONTROL MODULE SIDE.

- 1) Raise all four wheels of ground.
- 2) Turn ignition switch OFF.
- 3) Disconnect connector from A.B.S. control module.
- 4) Disconnect connector cover from connector.
 - (a) Remove screw from portion ①.
 - (b) Move rubber boot ② back (toward harness).
 - (c) Slide cover ③ in direction shown by arrow and remove.
- 5) Connect connector to A.B.S. control module.
- 6) Connect the oscilloscope to the A.B.S. control module connector in accordance with trouble code.
- 7) Turn ignition switch ON.

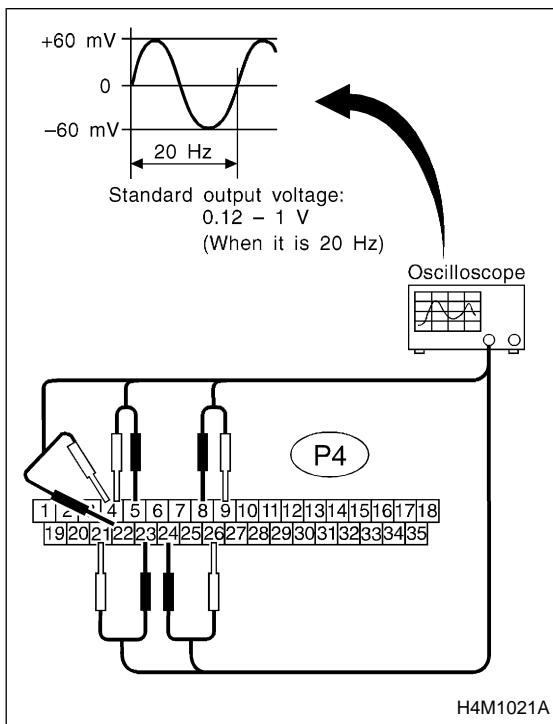

H4M1021A

8) Rotate wheels and measure voltage at specified frequency.

NOTE:

When this inspection is completed, the A.B.S. control module sometimes stores the trouble code 29.

TROUBLE CODE / Connector & terminal:

21 / (P4) No. 23 — No. 21

23 / (P4) No. 22 — No. 4: AWD

(P4) No. 5 — No. 4: FWD

25 / (P4) No. 24 — No. 26

27 / (P4) No. 8 — No. 9

Specified voltage: 0.12 — 1 V (When it is 20 Hz)

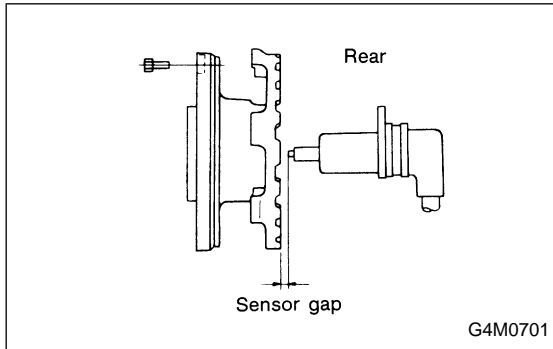
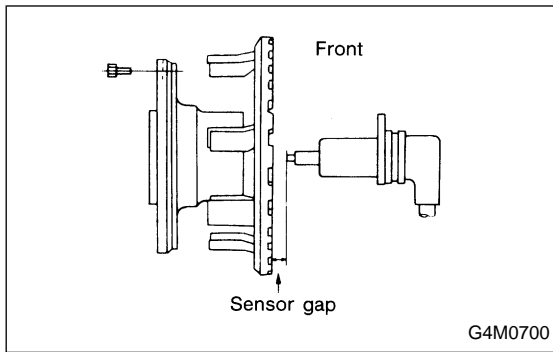

3. CHECK A.B.S. SENSOR MECHANICAL TROUBLE.

- 1) Dismount brake as outlined in manual to gain access to A.B.S. sensor and tone wheel for inspection.
- 2) Check pole piece and tone wheel for accumulation of foreign particles. If necessary, remove foreign particles and clean.
- 3) Check tone wheel teeth for cracks for deformities. If necessary, replace tone wheel (No. of teeth: 44) with a new one.
- 4) Check tone wheel for looseness.

Tightening torque:

10 — 16 N·m (1 — 1.6 kg-m, 7 — 12 ft-lb)

- 5) Measure tone wheel-to-pole piece gap over entire perimeter of the wheel.

Specifications	Front wheel	Rear wheel
	0.9 — 1.4 mm (0.035 — 0.055 in)	0.7 — 1.2 mm (0.028 — 0.047 in)

If measurements check out “Not OK”, adjust the gap using spacers (Part No. 26755AA000). If spacers cannot correct the gap, replace worn sensor or worn tone wheel.

- 6) Check hub runout.

Specifications	0.05 mm (0.0020 in)
----------------	---------------------

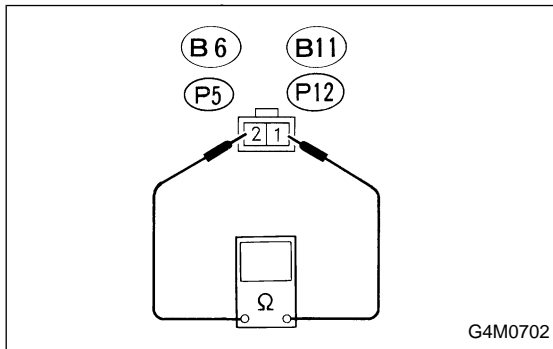

4. CHECK RESISTANCE OF A.B.S. SENSOR.

- 1) Turn ignition switch OFF.
- 2) Disconnect connector from A.B.S. sensor.
- 3) Measure resistance between A.B.S. sensor connector terminals.

TROUBLE CODE / Connector & terminal:

21 / (B6) No. 1 — No. 2

23 / (B11) No. 1 — No. 2

25 / (P5) No. 1 — No. 2

27 / (P12) No. 1 — No. 2

Specified resistance: 0.8 — 1.3 kΩ

**D: TROUBLE CODE 22, 24, 26 AND 28
— FAULTY A.B.S. SENSOR
(WHEN THERE IS NO OPEN CIRCUIT OR
SPEED SIGNAL INPUT.) —**

DIAGNOSIS:

- Faulty A.B.S. sensor/harness
- Faulty tone wheel
- Faulty A.B.S. control module

TROUBLE SYMPTOM:

- A.B.S. does not operate.

NOTE:

The A.B.S. control module will sense that the A.B.S. sensor circuit is “open” due to increased resistance but this trouble code will appear when the speed signal is not present or when it suddenly disappears while driving.

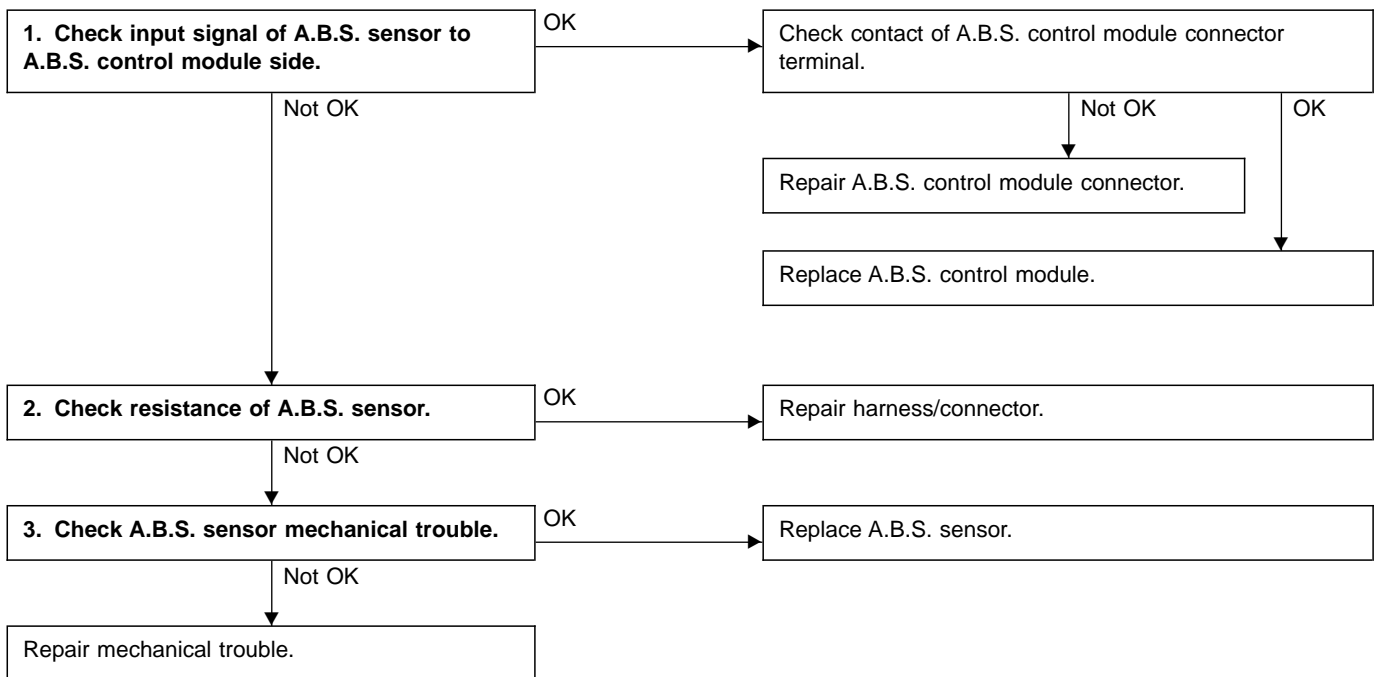

NOTE:

When checking A.B.S. sensor, carefully bend or swing connector and harness to check for improper contact or open circuits.

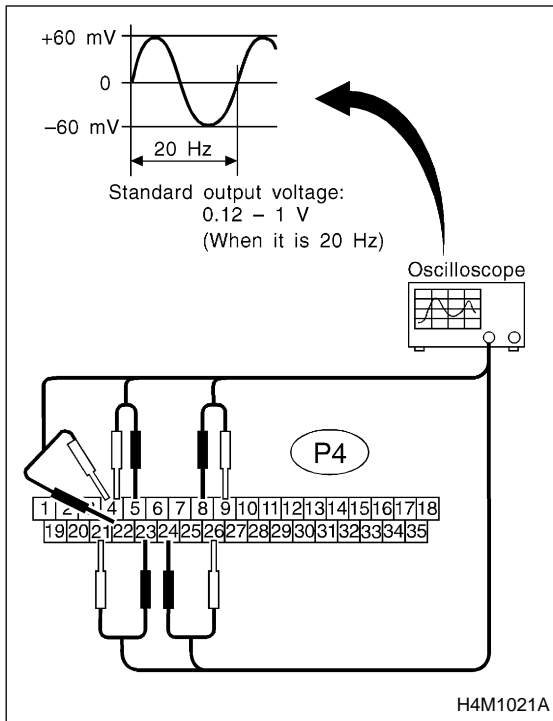

1. CHECK INPUT SIGNAL OF A.B.S. SENSOR TO A.B.S. CONTROL MODULE SIDE.

- 1) Raise all four wheels of ground.
- 2) Turn ignition switch OFF.
- 3) Disconnect connector from A.B.S. control module.
- 4) Disconnect connector cover from connector. <Ref. to 4-4 [T6C2].>
- 5) Connect connector to A.B.S. control module.
- 6) Connect the oscilloscope to the A.B.S. control module connector in accordance with the trouble code.
- 7) Turn ignition switch ON.
- 8) Rotate wheels and measure voltage at specified frequency.

NOTE:

When this inspection is completed, the A.B.S. control module sometimes memorizes the trouble code 29.

TROUBLE CODE / Connector & terminal:

- 21 / (P4) No. 23 — No. 21
- 23 / (P4) No. 22 — No. 4: AWD
- (P4) No. 5 — No. 4: FWD
- 25 / (P4) No. 24 — No. 26
- 27 / (P4) No. 8 — No. 9
- Specified voltage: 0.12 — 1 V (When it is 20 Hz)**

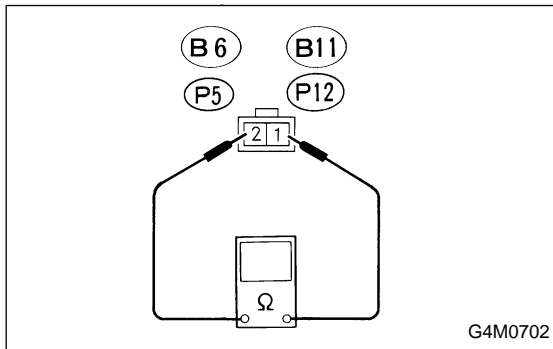

2. CHECK RESISTANCE OF A.B.S. SENSOR.

- 1) Turn ignition switch OFF.
- 2) Disconnect connector from A.B.S. sensor.
- 3) Measure resistance between A.B.S. sensor connector terminals.

TROUBLE CODE / Connector & terminal:

- 21 / (B6) No. 1 — No. 2
- 23 / (B11) No. 1 — No. 2
- 25 / (P5) No. 1 — No. 2
- 27 / (P12) No. 1 — No. 2
- Specified resistance: 0.8 — 1.3 kΩ**

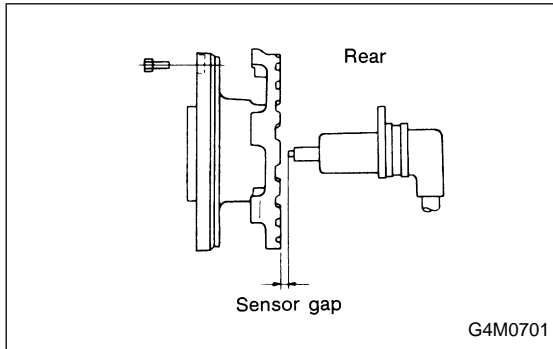
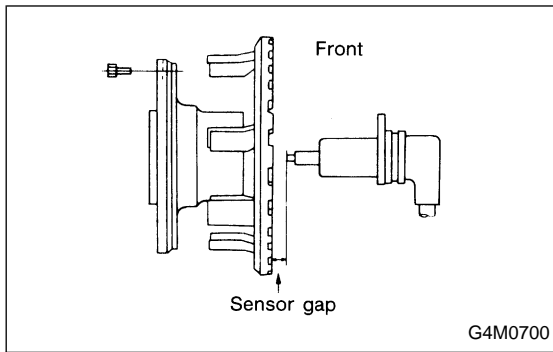

3. CHECK A.B.S. SENSOR MECHANICAL TROUBLE.

- 1) Dismount brake as outlined in manual to gain access to A.B.S. sensor and tone wheel for inspection.
- 2) Check pole piece and tone wheel for accumulation of foreign particles. If necessary, remove foreign particles and clean.
- 3) Check tone wheel teeth for cracks for deformities. If necessary, replace tone wheel (No. of teeth: 44) with a new one.
- 4) Check tone wheel for looseness.

Tightening torque:

10 — 16 N·m (1 — 1.6 kg-m, 7 — 12 ft-lb)

- 5) Measure tone wheel-to-pole piece gap over entire perimeter of the wheel.

	Front wheel	Rear wheel
Specifications	0.9 — 1.4 mm (0.035 — 0.055 in)	0.7 — 1.2 mm (0.028 — 0.047 in)

If measurements check out "Not OK", adjust the gap using spacers (Part No. 26755AA000). If spacers cannot correct the gap, replace worn sensor or worn tone wheel.

- 6) Check hub runout.

Specifications	0.05 mm (0.0020 in)
----------------	---------------------

**E: TROUBLE CODE 29
— FAULTY TONE WHEEL, ETC. —**

DIAGNOSIS:

- Faulty tone wheel
- Faulty A.B.S. control module

TROUBLE SYMPTOM:

- A.B.S. does not operate.

NOTE:

When the wheels turn freely for a long time, such as when the vehicle is towed or jacked-up, or when steering wheel is continuously turned all the way, this trouble code may sometimes occur.

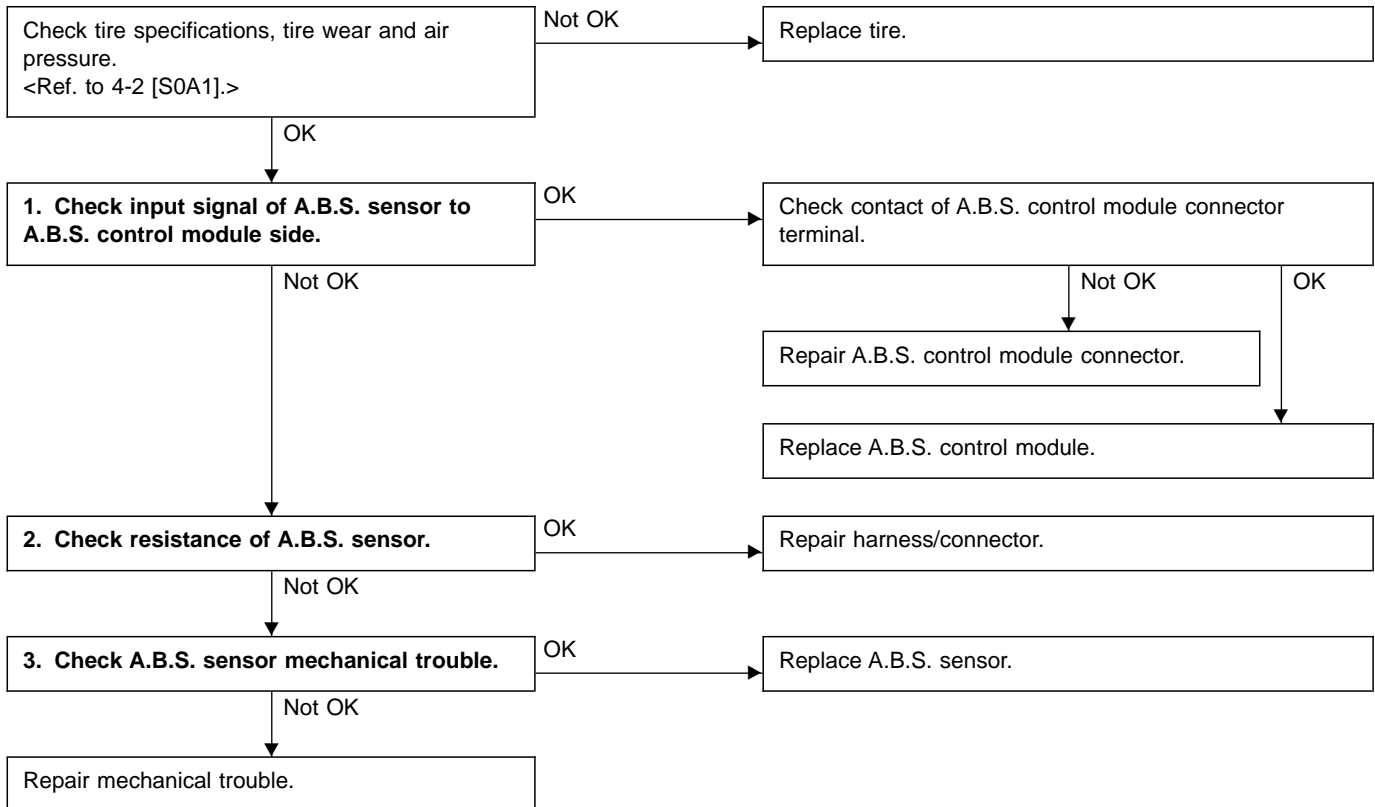

NOTE:

When checking A.B.S. sensor, carefully bend or swing connector and harness to check for improper contact or open circuits.

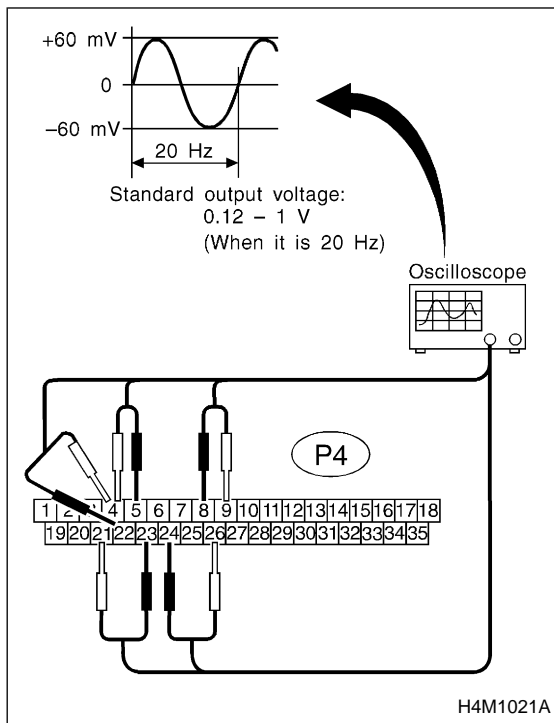

1. CHECK INPUT SIGNAL OF A.B.S. SENSOR TO A.B.S. CONTROL MODULE SIDE.

- 1) Raise all four wheels of ground.
- 2) Turn ignition switch OFF.
- 3) Disconnect connector from A.B.S. control module.
- 4) Disconnect connector cover from connector. <Ref. to 4-4 [T6C2].>
- 5) Connect connector to A.B.S. control module.
- 6) Connect the oscilloscope to the A.B.S. control module connector in accordance with the trouble code.
- 7) Turn ignition switch ON.
- 8) Rotate wheels and measure voltage at specified frequency.

NOTE:

When this inspection is completed, the A.B.S. control module sometimes memorizes the trouble code 29.

TROUBLE CODE / Connector & terminal:

- 21 / (P4) No. 23 — No. 21
- 23 / (P4) No. 22 — No. 4: AWD
- (P4) No. 5 — No. 4: FWD
- 25 / (P4) No. 24 — No. 26
- 27 / (P4) No. 8 — No. 9
- Specified voltage: 0.12 — 1 V (When it is 20 Hz)**

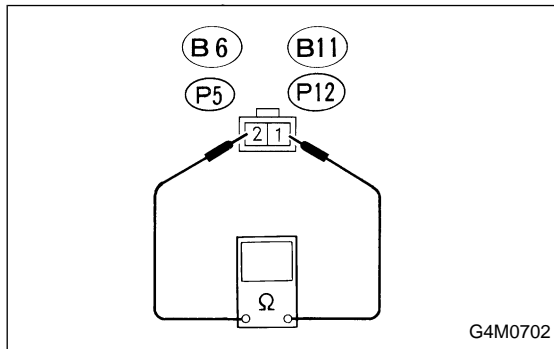

2. CHECK RESISTANCE OF A.B.S. SENSOR.

- 1) Turn ignition switch OFF.
- 2) Disconnect connector from A.B.S. sensor.
- 3) Measure resistance between A.B.S. sensor connector terminals.

TROUBLE CODE / Connector & terminal:

- 21 / (B6) No. 1 — No. 2
- 23 / (B11) No. 1 — No. 2
- 25 / (P5) No. 1 — No. 2
- 27 / (P12) No. 1 — No. 2
- Specified resistance: 0.8 — 1.3 kΩ**

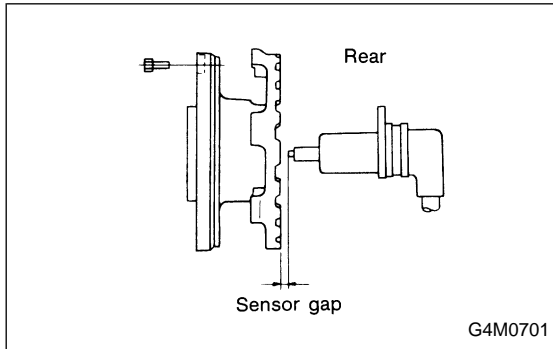
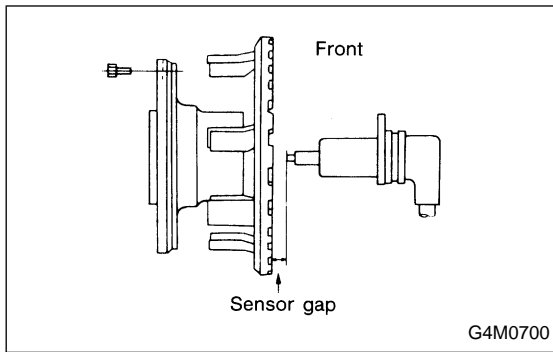

3. CHECK A.B.S. SENSOR MECHANICAL TROUBLE.

- 1) Dismount brake as outlined in manual to gain access to A.B.S. sensor and tone wheel for inspection.
- 2) Check pole piece and tone wheel for accumulation of foreign particles. If necessary, remove foreign particles and clean.
- 3) Check tone wheel teeth for cracks for deformities. If necessary, replace tone wheel (No. of teeth: 44) with a new one.
- 4) Check tone wheel for looseness.

Tightening torque:

10 — 16 N·m (1 — 1.6 kg-m, 7 — 12 ft-lb)

- 5) Measure tone wheel-to-pole piece gap over entire perimeter of the wheel.

Specifications	Front wheel	Rear wheel
	0.9 — 1.4 mm (0.035 — 0.055 in)	0.7 — 1.2 mm (0.028 — 0.047 in)

If measurements check out “Not OK”, adjust the gap using spacers (Part No. 26755AA000). If spacers cannot correct the gap, replace worn sensor or worn tone wheel.

- 6) Check hub runout.

Specifications	0.05 mm (0.0020 in)
----------------	---------------------

**F: TROUBLE CODE 31, 33 AND 39
— FAULTY SOLENOID VALVE CIRCUIT(S) IN
HYDRAULIC UNIT —**

DIAGNOSIS:

- Faulty harness/connector
- Faulty solenoid valve in hydraulic unit
- Faulty A.B.S. control module

TROUBLE SYMPTOM:

- A.B.S. does not operate.

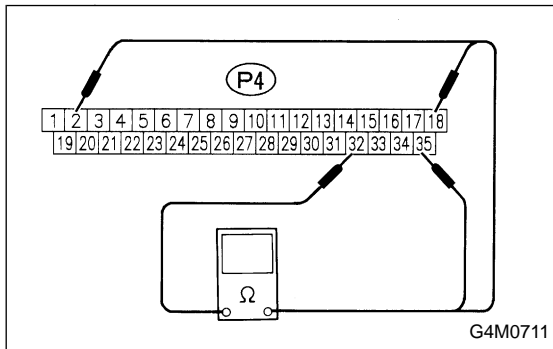
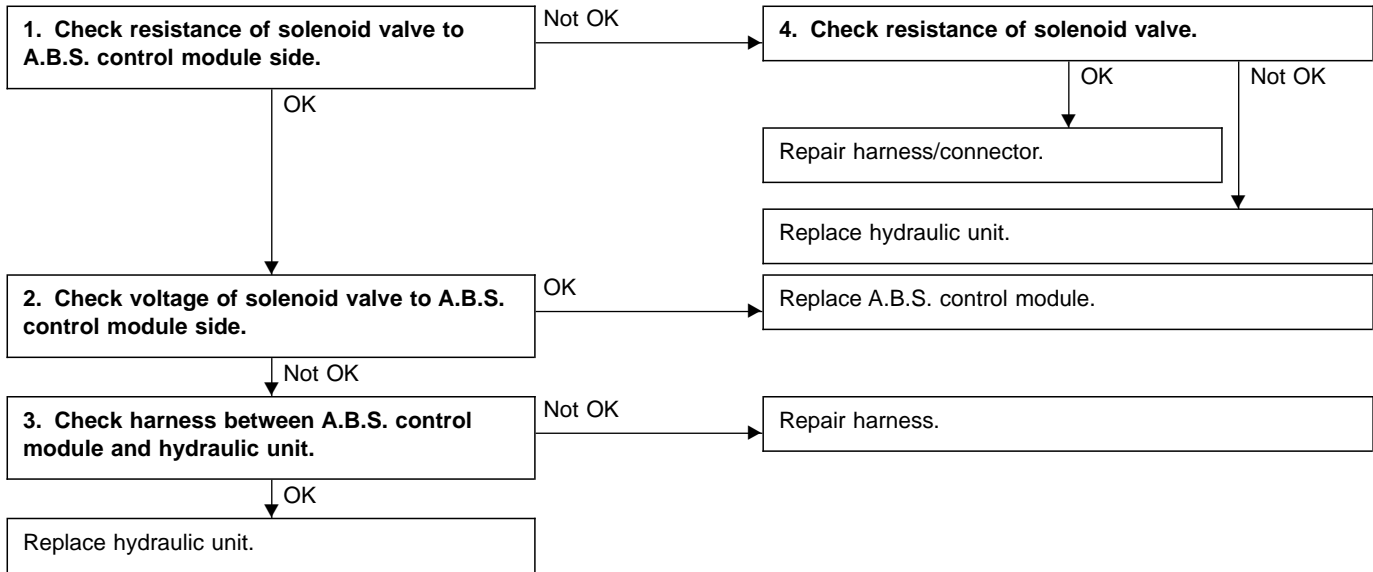

1. CHECK RESISTANCE OF SOLENOID VALVE TO A.B.S. CONTROL MODULE SIDE.

- 1) Turn ignition switch OFF.
- 2) Disconnect connector from A.B.S. control module.
- 3) Measure resistance between A.B.S. control module connector terminals.

TROUBLE CODE / Connector & terminal:

31 / (P4) No. 35 — No. 32

33 / (P4) No. 2 — No. 32

39 / (P4) No. 18 — No. 32

Specified resistance: approx. 1 Ω

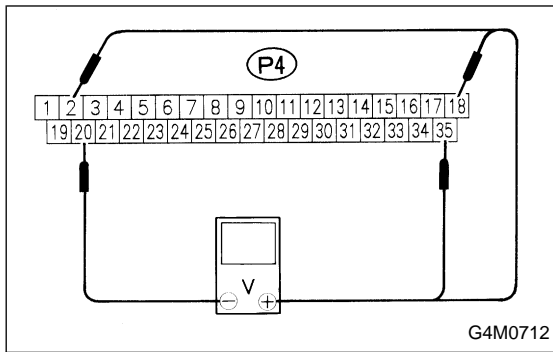

2. CHECK VOLTAGE OF SOLENOID VALVE TO A.B.S. CONTROL MODULE SIDE.

- 1) Turn ignition switch OFF.
- 2) Disconnect valve relay from hydraulic unit.
- 3) Turn ignition switch ON.
- 4) Measure voltage between A.B.S. control module connector terminals.

TROUBLE CODE / Connector & terminal:

- 31 / (P4) No. 35 — No. 20**
- 33 / (P4) No. 2 — No. 20**
- 39 / (P4) No. 18 — No. 20**
- Specified voltage: 0 V**

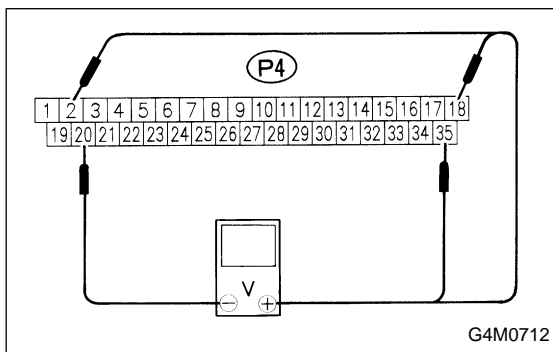

3. CHECK HARNESS BETWEEN A.B.S. CONTROL MODULE AND HYDRAULIC UNIT.

- 1) Turn ignition switch OFF.
- 2) Disconnect connector from hydraulic unit.
- 3) Turn ignition switch ON.
- 4) Measure voltage between A.B.S. control module connector terminals.

TROUBLE CODE / Connector & terminal:

- 31 / (P4) No. 35 — No. 20**
- 33 / (P4) No. 2 — No. 20**
- 39 / (P4) No. 18 — No. 20**
- Specified voltage: 0 V**

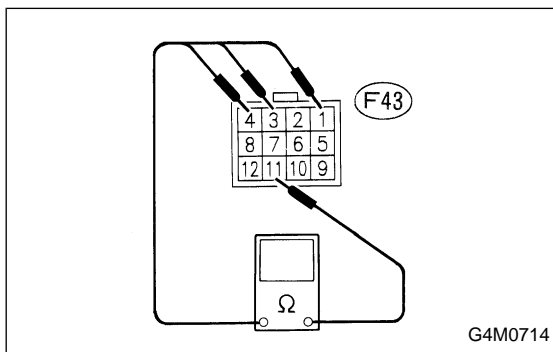

4. CHECK RESISTANCE OF SOLENOID VALVE.

- 1) Turn ignition switch OFF.
- 2) Disconnect connector from hydraulic unit.
- 3) Measure resistance between hydraulic unit terminals.

TROUBLE CODE / Connector & terminal:

- 31 / to (F43) No. 4 — No. 11**
- 33 / to (F43) No. 3 — No. 11**
- 39 / to (F43) No. 1 — No. 11**
- Specified resistance: approx. 1 Ω**

**G: TROUBLE CODE 41
— FAULTY A.B.S. CONTROL MODULE —**

DIAGNOSIS:

- Faulty A.B.S. control module

TROUBLE SYMPTOM:

- A.B.S. does not operate.

Replace A.B.S. control module.

**H: TROUBLE CODE 42
— SOURCE VOLTAGE IS LOW. —**

DIAGNOSIS:

- Faulty battery
- Faulty A.B.S. control module
- Faulty harness
- Faulty valve relay

TROUBLE SYMPTOM:

- A.B.S. does not operate.

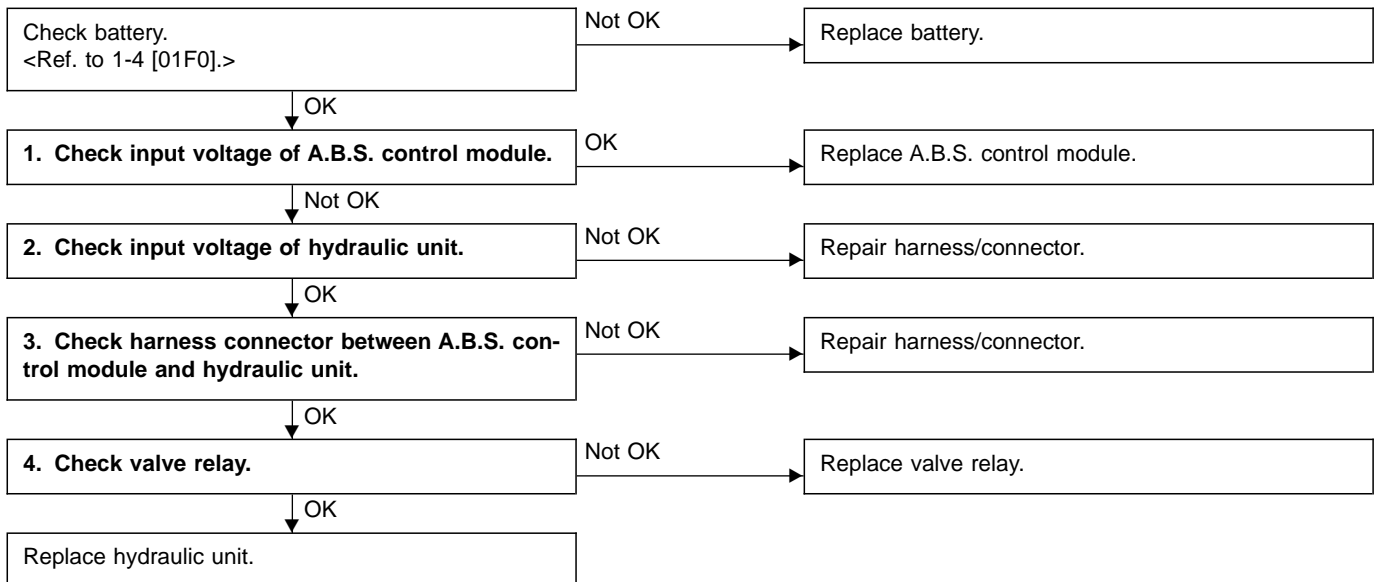

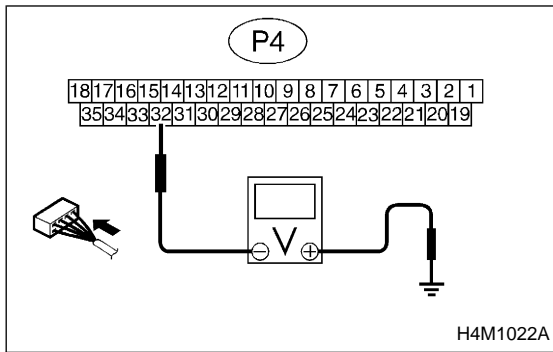

1. CHECK INPUT VOLTAGE OF A.B.S. CONTROL MODULE.

- 1) Turn ignition switch OFF.
- 2) Disconnect connector from A.B.S. control module.
- 3) Disconnect connector cover from connector. <Ref. to 4-4 [T6C2].>
- 4) Connect connector to A.B.S. control module.
- 5) Turn ignition switch ON.
- 6) Measure input voltage between A.B.S. control module connector and body.

Connector & terminal / Specified voltage:

(P4) No. 32 — Body / 9.2 — 12 V

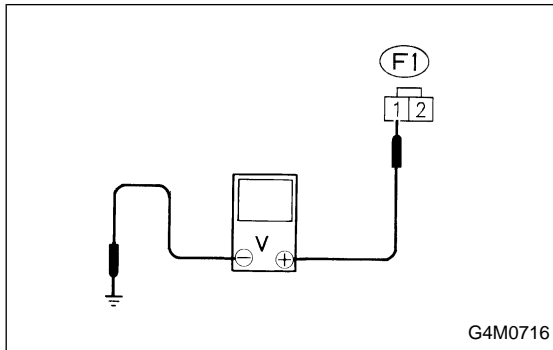

2. CHECK INPUT VOLTAGE OF HYDRAULIC UNIT.

- 1) Turn ignition switch OFF.
- 2) Disconnect connector from hydraulic unit.
- 3) Turn ignition switch ON.
- 4) Measure input voltage between hydraulic unit connector and body.

Connector & terminal / Specified voltage:

(F1) No. 1 — Body / 10 — 12 V

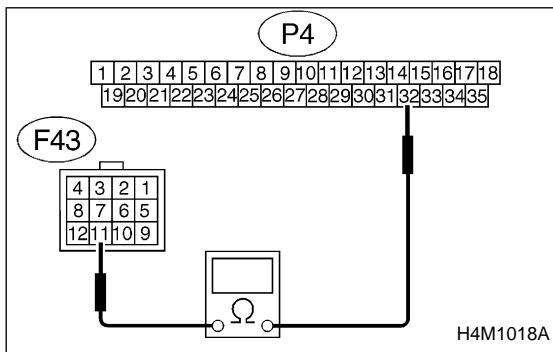

3. CHECK HARNESS CONNECTOR BETWEEN A.B.S. CONTROL MODULE AND HYDRAULIC UNIT.

- 1) Turn ignition switch OFF.
- 2) Disconnect connector from A.B.S. control module and hydraulic unit.
- 3) Measure resistance between A.B.S. control module and hydraulic unit.

Connector & terminal / Specified resistance:

(P4) No. 32 — (F43) No. 11 / 0 Ω

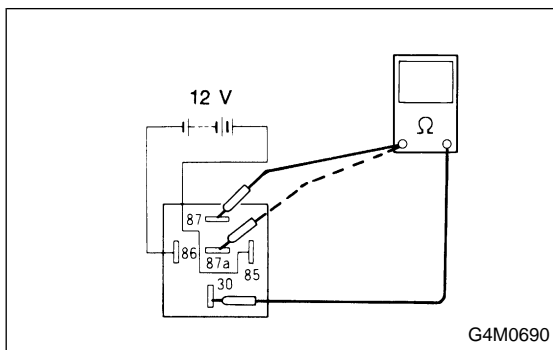

4. CHECK VALVE RELAY.

- 1) Remove valve relay.
- 2) Attach circuit tester probes to terminals, as shown in figure.
- 3) Measure resistance between respective terminals.

Terminal / Specified resistance:

No. 87 — 30 / 0 Ω (when 12 volts applied.)

No. 87 — 30 / 1 MΩ (when no voltage is applied.)

No. 87a — 30 / 1 MΩ (when 12 volts applied.)

No. 87a — 30 / 0 Ω (when no voltage is applied.)

**I: TROUBLE CODE 51
— FAULTY VALVE RELAY —**

DIAGNOSIS:

- Faulty valve relay
- Faulty harness
- Faulty A.B.S. control module

TROUBLE SYMPTOM:

- A.B.S. does not operate.

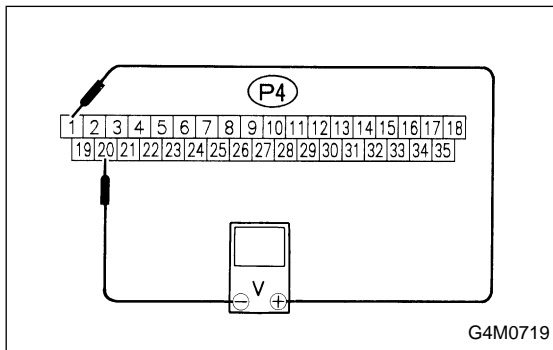
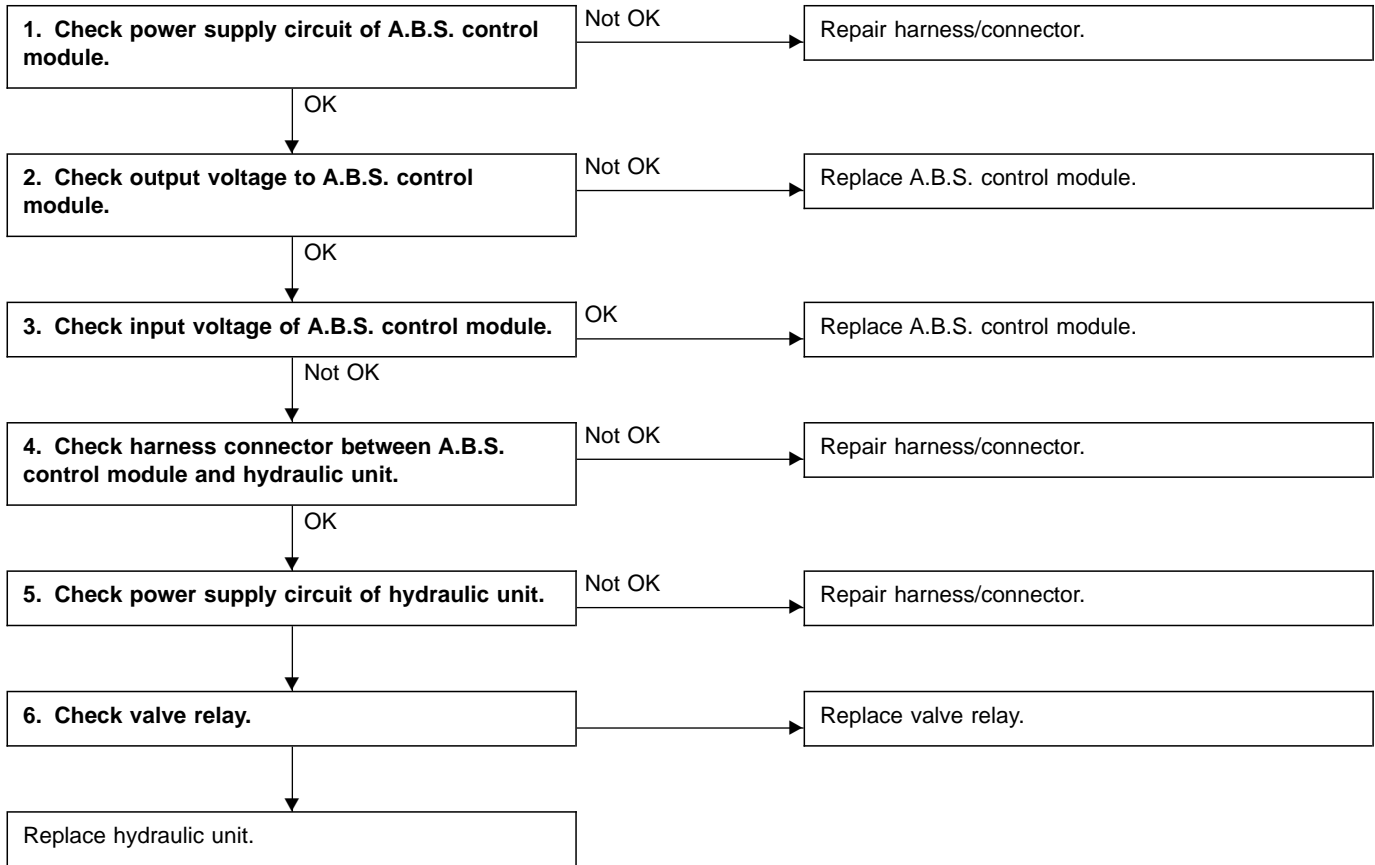

1. CHECK POWER SUPPLY CIRCUIT OF A.B.S. CONTROL MODULE.

- 1) Turn ignition switch OFF.
- 2) Disconnect connector from A.B.S. control module.
- 3) Turn ignition switch ON.
- 4) Measure voltage between A.B.S. control module connector terminals.

Connector & terminal / Specified voltage:
(P4) No. 1 — No. 20 / 10 — 12 V

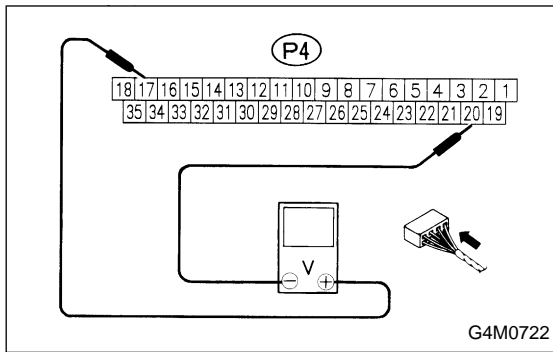

2. CHECK OUTPUT VOLTAGE TO A.B.S. CONTROL MODULE.

- 1) Turn ignition switch OFF.
- 2) Disconnect connector from A.B.S. control module.
- 3) Disconnect connector cover from connector.
- 4) Connect connector to A.B.S. control module.
- 5) Turn ignition switch ON.
- 6) Measure voltage between A.B.S. control module connector terminals.

Connector & terminal / Specified voltage:
(P4) No. 17 — No. 20 / 10 — 12 V

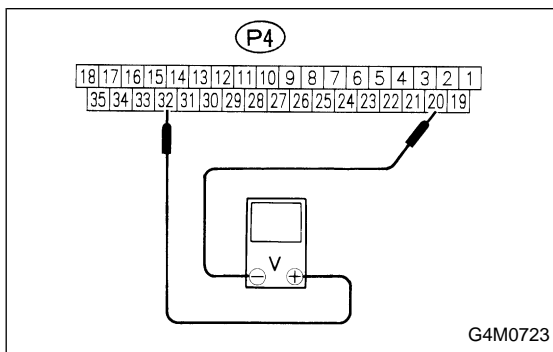

3. CHECK INPUT VOLTAGE OF A.B.S. CONTROL MODULE.

- 1) Turn ignition switch ON.
- 2) Measure voltage between A.B.S. control module connector terminals.

Connector & terminal / Specified voltage:
(P4) No. 32 — No. 20 / 10 — 12 V

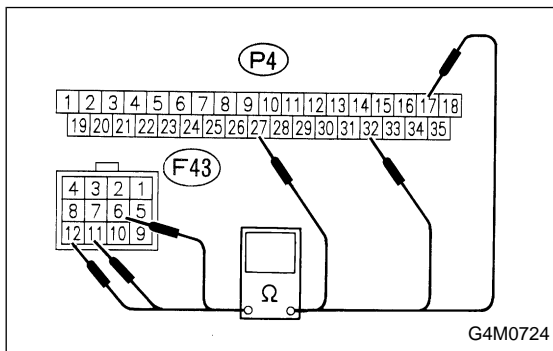

4. CHECK HARNESS CONNECTOR BETWEEN A.B.S. CONTROL MODULE AND HYDRAULIC UNIT.

- 1) Turn ignition switch OFF.
- 2) Disconnect connector from A.B.S. control module and hydraulic unit.
- 3) Measure resistance between A.B.S. control module and hydraulic unit.

Connector & terminal / Specified resistance:
(P4) No. 17 — (F43) No. 6 / 0 Ω
(P4) No. 32 — (F43) No. 11 / 0 Ω
(P4) No. 27 — (F43) No. 12 / 0 Ω

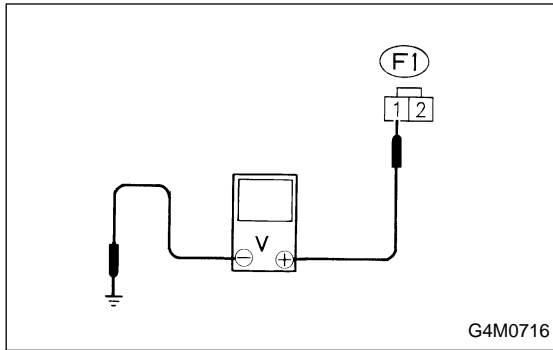

5. CHECK POWER SUPPLY CIRCUIT OF HYDRAULIC UNIT.

- 1) Turn ignition switch OFF.
- 2) Disconnect connector from hydraulic unit.
- 3) Turn ignition switch ON.
- 4) Measure voltage between hydraulic unit and body.

Connector & terminal / Specified voltage:

(F1) No. 1 — Body / 10 — 12 V

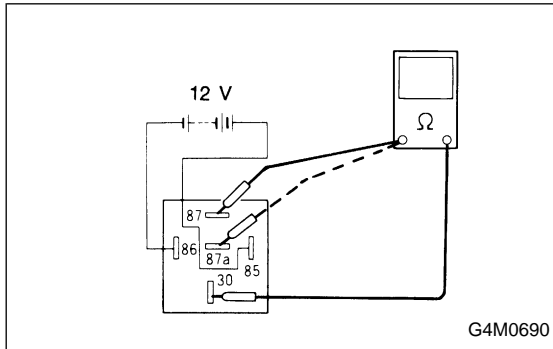

6. CHECK VALVE RELAY.

- 1) Remove valve relay.
- 2) Attach circuit tester probes to terminals, as shown in figure.
- 3) Measure resistance between respective terminals.

Terminal / Specified resistance:

No. 87 — 30 / 0 Ω (when 12 volts applied.)

No. 87 — 30 / 1 M Ω (when no voltage is applied.)

No. 87a — 30 / 1 M Ω (when 12 volts applied.)

No. 87a — 30 / 0 Ω (when no voltage is applied.)

**J: TROUBLE CODE 52
— FAULTY HYDRAULIC MOTOR AND/OR
MOTOR RELAY —**

DIAGNOSIS:

- Faulty motor relay
- Faulty hydraulic unit
- Faulty harness
- Faulty A.B.S. control module

TROUBLE SYMPTOM:

- A.B.S. does not operate.

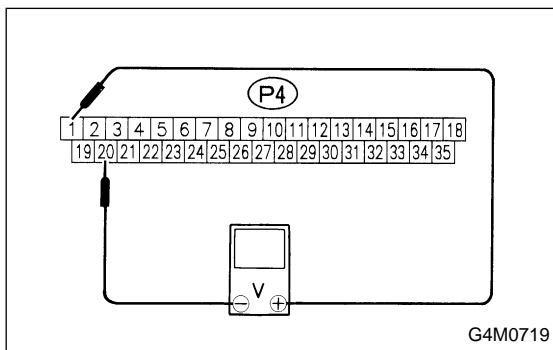
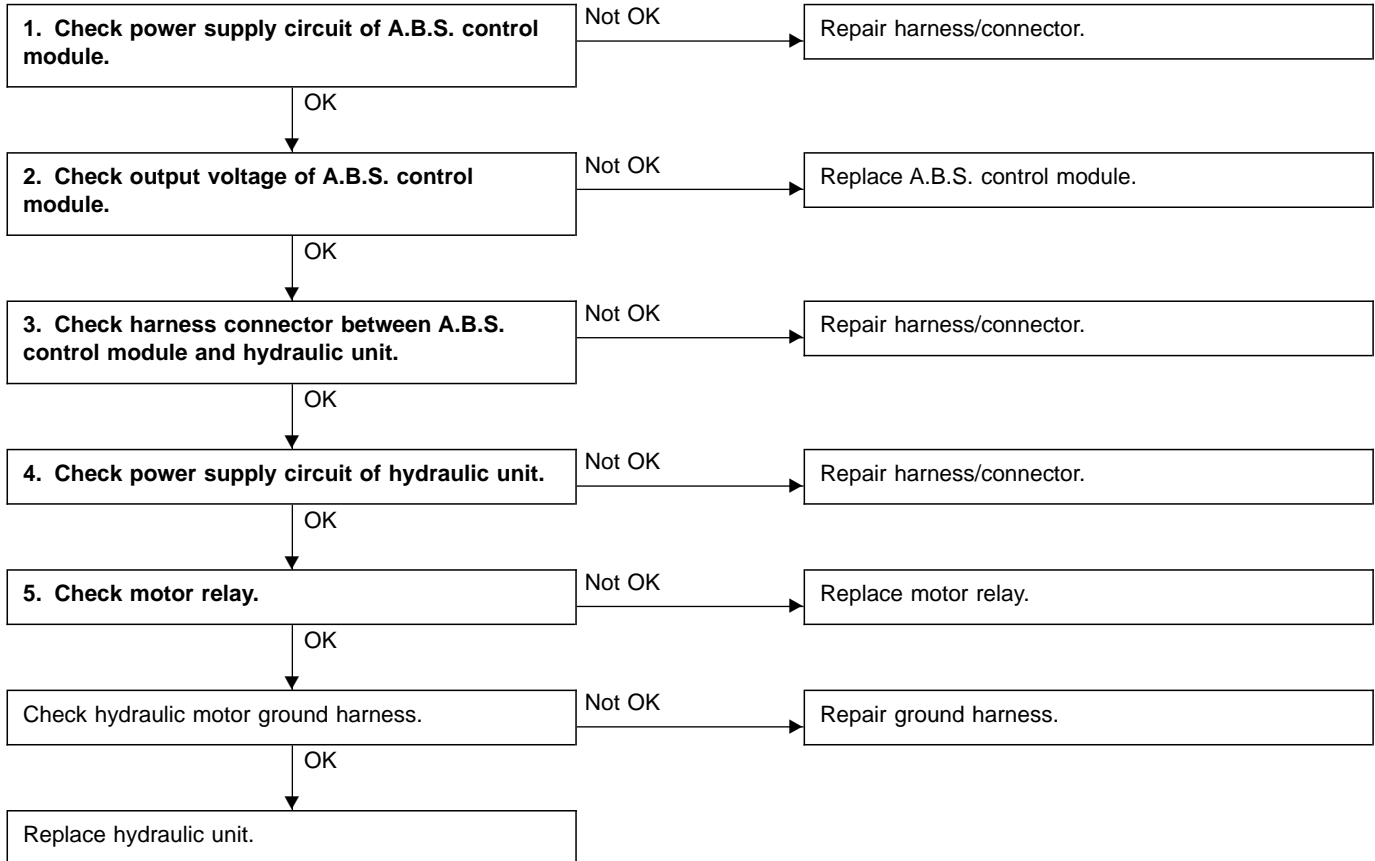

1. CHECK POWER SUPPLY CIRCUIT OF A.B.S. CONTROL MODULE.

- 1) Turn ignition switch OFF.
- 2) Disconnect connector from A.B.S. control module.
- 3) Turn ignition switch ON.
- 4) Measure voltage between A.B.S. control module connector terminals.

Connector & terminal / Specified voltage:
(P4) No. 1 — No. 20 / 10 — 12 V

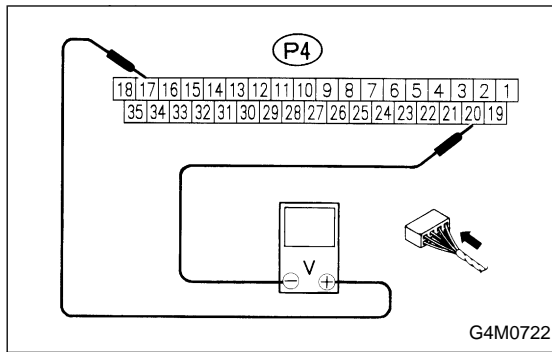

2. CHECK OUTPUT VOLTAGE OF A.B.S. CONTROL MODULE.

- 1) Turn ignition switch OFF.
- 2) Disconnect connector from A.B.S. control module.
- 3) Disconnect connector cover from connector. <Ref. to 4-4 [T6C2].>
- 4) Connect connector to A.B.S. control module.
- 5) Turn ignition switch ON.
- 6) Measure voltage between A.B.S. control module connector terminals.

Connector & terminal / Specified voltage:

(P4) No. 17 — No. 20 / 10 — 12 V

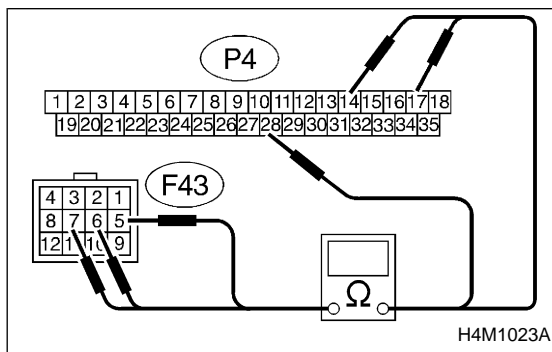

3. CHECK HARNESS CONNECTOR BETWEEN A.B.S. CONTROL MODULE AND HYDRAULIC UNIT.

- 1) Turn ignition switch OFF.
- 2) Disconnect connector from A.B.S. control module.
- 3) Disconnect connector from hydraulic unit.
- 4) Measure resistance between A.B.S. control module connector and hydraulic unit connector.

Connector & terminal / Specified resistance:

(P4) No. 17 — (F43) No. 6 / 0 Ω

(P4) No. 28 — (F43) No. 5 / 0 Ω

(P4) No. 14 — (F43) No. 7 / 0 Ω

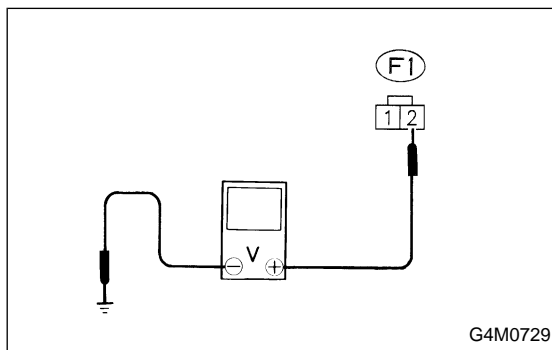

4. CHECK POWER SUPPLY CIRCUIT OF HYDRAULIC UNIT.

- 1) Turn ignition switch OFF.
- 2) Disconnect connector from hydraulic unit.
- 3) Measure voltage between hydraulic unit connector and body.

Connector & terminal / Specified voltage:

(F1) No. 2 — Body / 10 — 12 V

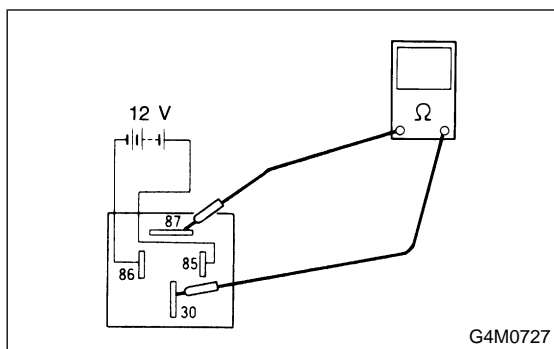
**5. CHECK MOTOR RELAY.**

- 1) Remove motor relay.
- 2) Attach circuit tester probes to terminals, as shown in figure.
- 3) Measure resistance between terminals.

Terminal / Specified resistance:

No. 30 — 87 / 0 Ω (when 12 volts applied.)

No. 30 — 87 / 1 M Ω , min. (when no voltage is applied.)

**K: TROUBLE CODE 54
— FAULTY STOP LIGHT CIRCUIT —**

DIAGNOSIS:

- Faulty stop light circuit.
- Faulty harness
- Faulty A.B.S. control module

TROUBLE SYMPTOM:

- A.B.S. does not operate.

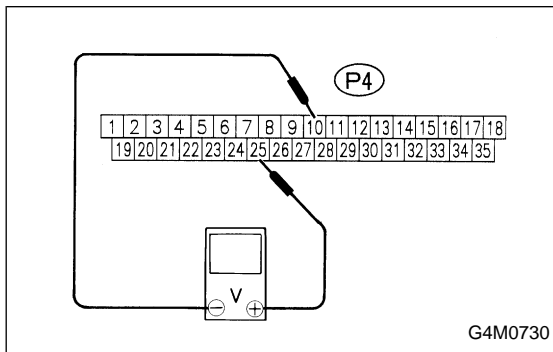
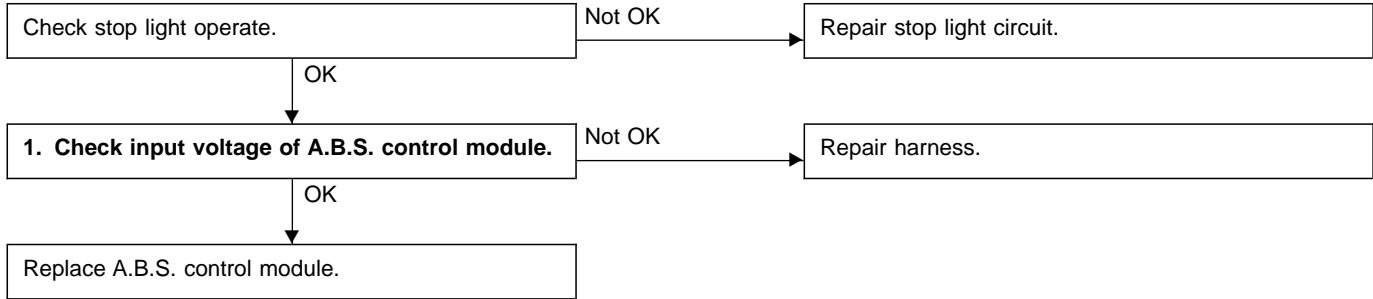

1. CHECK INPUT VOLTAGE OF A.B.S. CONTROL MODULE.

- 1) Turn ignition switch OFF.
- 2) Disconnect connector from A.B.S. control module.
- 3) Measure voltage between A.B.S. control module connector terminals.

Connector & terminal / Specified voltage:
(P4) No. 25 — No. 10 / More than 4 V (when brake pedal is depressed.)

**L: TROUBLE CODE 56
— USE OF IMPROPER A.B.S. CONTROL
MODULE SPECIFICATION, OR FAULTY G
SENSOR —**

DIAGNOSIS:

- Improper A.B.S. control module specification
- Faulty G sensor
- Faulty G sensor harness and connector

TROUBLE SYMPTOM:

- A.B.S. does not operate.
- A.B.S. activates faster than specifications when braking on high “μ” (dry asphalt) road.
- Warning light comes on and trouble code “56” is displayed approximately 20 seconds after vehicle starts.

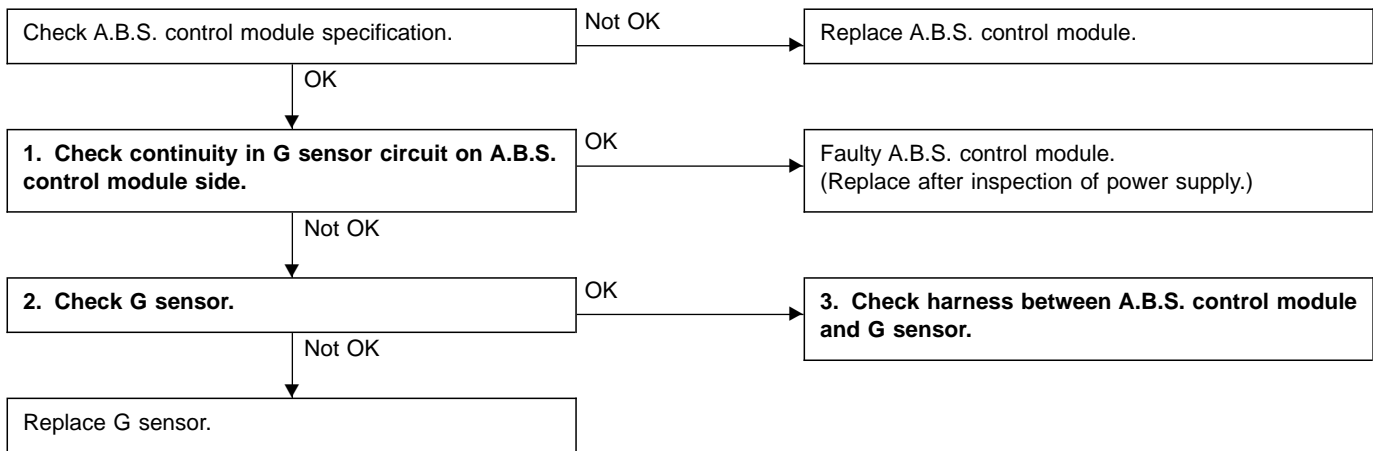

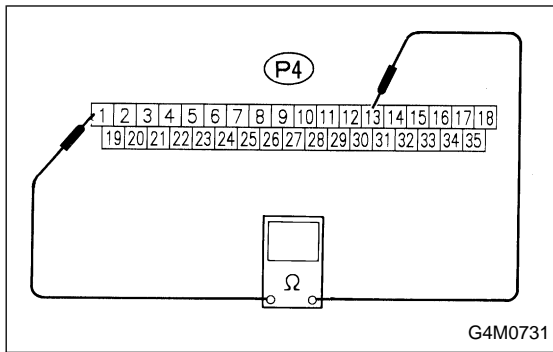

1. CHECK CONTINUITY IN G SENSOR CIRCUIT ON A.B.S. CONTROL MODULE SIDE.

- 1) Position vehicle on a flat surface.
- 2) Disconnect connector from A.B.S. control module.
- 3) Disassemble connector.
- 4) Measure resistance between A.B.S. control module connector terminals.

Connector & terminal / Specified Resistance:
(P4) No. 1 — No. 13 / 550 — 670 Ω

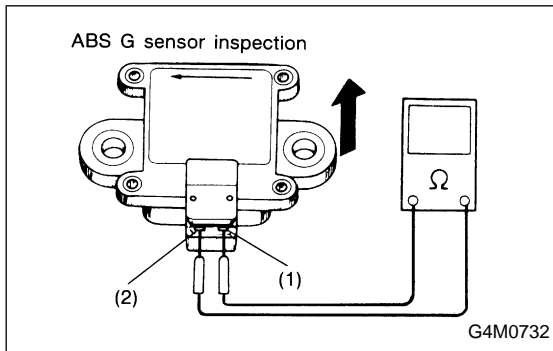

2. CHECK G SENSOR.

- 1) Disconnect G sensor connector.
- 2) Measure resistance between G sensor terminals. (Ensure that G sensor is horizontal during measurement.)

Specified Resistance:
550 — 670 Ω

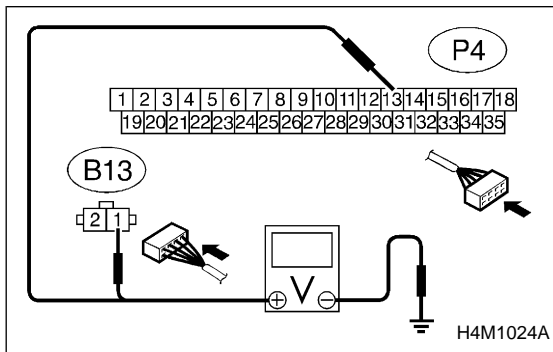

3. CHECK HARNESS BETWEEN A.B.S. CONTROL MODULE AND G SENSOR.

- 1) Turn ignition switch ON.
- 2) Connect G sensor connector.
- 3) Measure voltage between connector and body.

Connector & terminal / Specified Voltage:
(B13) No. 1 — Body / 10 — 12 V
(P4) No. 13 — Body / 10 — 12 V

NOTE:

When voltage checks out "OK", replace A.B.S. control module.