

1. Starter

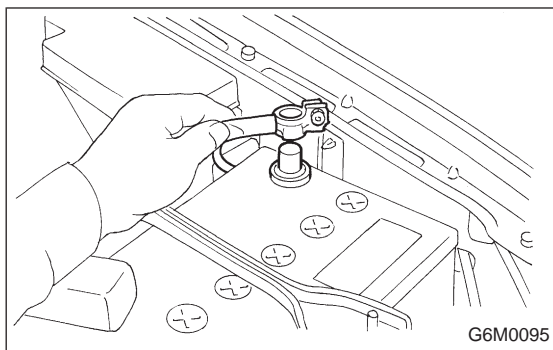

G6M0095

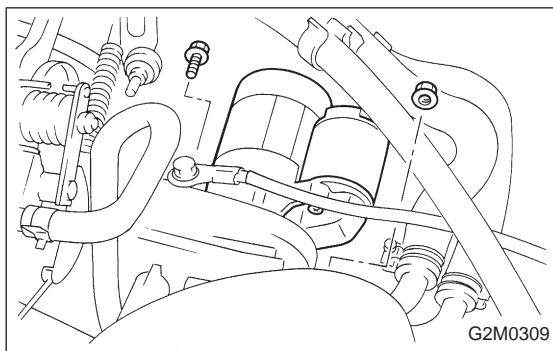

G2M0309

1. Starter

A: REMOVAL AND INSTALLATION

- 1) Disconnect battery ground cable.
- 2) Disconnect connector and terminal from starter.
- 3) Remove starter from transmission.
- 4) Installation is in the reverse order of removal.

Tightening torque:

46 — 54 N·m (4.7 — 5.5 kg·m, 34 — 40 ft-lb)

B: TEST

1. SWITCH ASSEMBLY OPERATION

- 1) Connect terminal S of switch assembly to positive terminal of battery with a lead wire, and starter body to ground terminal of battery. Pinion should be forced endwise on shaft.

CAUTION:

With pinion forced endwise on shaft, starter motor can sometimes rotate because current flows, through pull-in coil, to motor. This is not a problem.

- 2) Disconnect connector from terminal M, and connect positive terminal of battery and terminal M using a lead wire and ground terminal to starter body. In this test set up, pinion should return to its original position even when it is pulled out with a screwdriver.

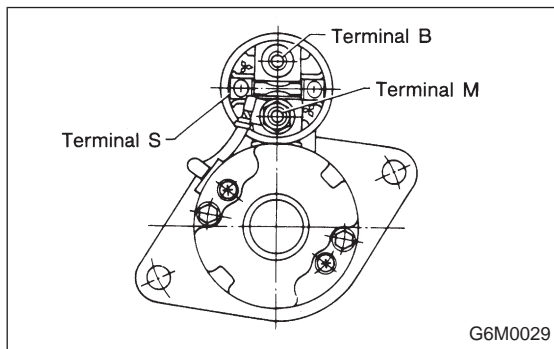

G6M0029

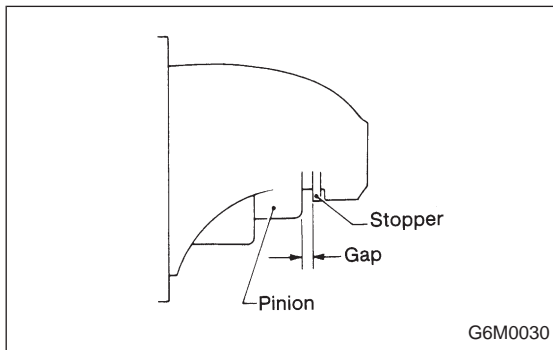

G6M0030

2. PINION GAP

- 1) With pinion forced endwise on shaft, as outlined in step 1) above, measure pinion gap.

Pinion gap:

0.5 — 2.0 mm (0.020 — 0.079 in)

If motor is running with the pinion forced endwise on the shaft, disconnect connector from terminal M of switch assembly and connect terminal M to ground terminal (-) of battery with a lead wire. Next, gently push pinion back with your fingertips and measure pinion gap.

2) If pinion gap is outside specified range, remove or add number of adjustment washers used on the mounting surface of switch assembly until correct pinion gap is obtained.

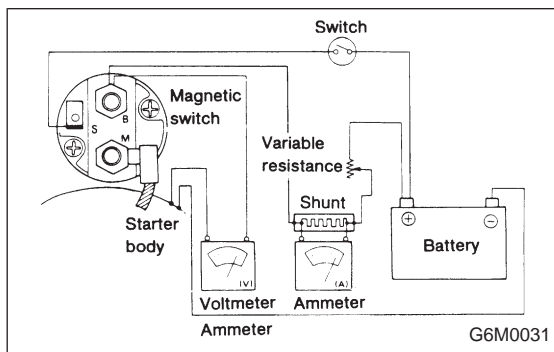

3. PERFORMANCE TEST

The starter should be submitted to performance tests whenever it has been overhauled, to assure its satisfactory performance when installed on the engine.

Three performance tests, no-load test, load test, and lock test, are presented here; however, if the load test and lock test cannot be performed, carry out at least the no-load test.

For these performance tests, use the circuit shown in figure.

1) No-load test

With switch on, adjust the variable resistance to obtain 11 V, take the ammeter reading and measure the starter speed. Compare these values with the specifications.

No-load test (Standard):

Voltage / Current

11 V / 90 A max.

Rotating speed

3,000 rpm / min.

2) Load test

Apply the specified braking torque to starter. The condition is satisfactory if the current draw and starter speed are within specifications.

Load test (Standard):

Voltage / Load

7.7 V / 10 N·m (1.0 kg·m, 7 ft·lb)

Current / Speed

300 A max. / 1,000 rpm / min.

3) Lock test

With starter stalled, or not rotating, measure the torque developed and current draw when the voltage is adjusted to the specified voltage.

Lock test (Standard):

Voltage / Current

4 V / 980 A max.

Torque

23 N·m (2.3 kg-m, 17 ft-lb) min.

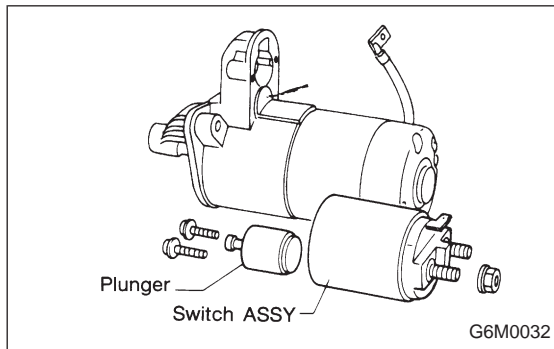
**C: DISASSEMBLY**

1) Loosen nut which holds terminal M of switch assembly, and disconnect connector.

2) Remove bolts which hold switch assembly, and remove switch assembly, plunger and plunger spring from starter as a unit.

CAUTION:

Be careful because pinion gap adjustment washer may sometimes be used on the mounting surface of switch assembly.

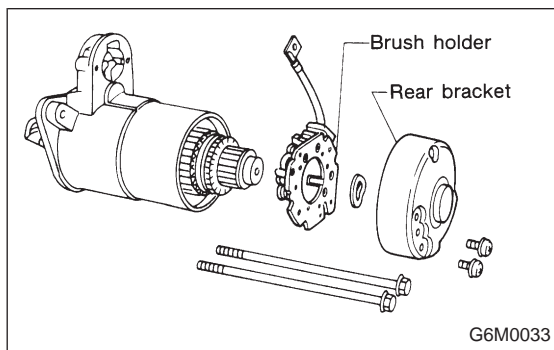

3) Remove both through-bolts and brush holder screws, and detach rear bracket and brush holder.

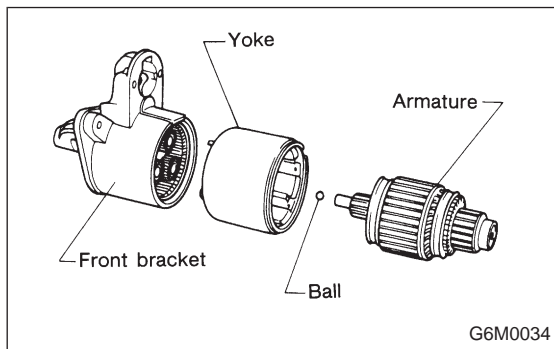

4) Remove armature and yoke. Ball used as a bearing will then be removed from the end of armature.

CAUTION:

Be sure to mark an alignment mark on yoke and front bracket before removing yoke.

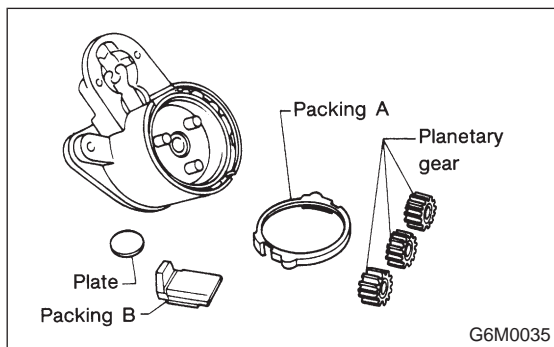

5) Remove packing A, three planetary gears, packing B and plate.

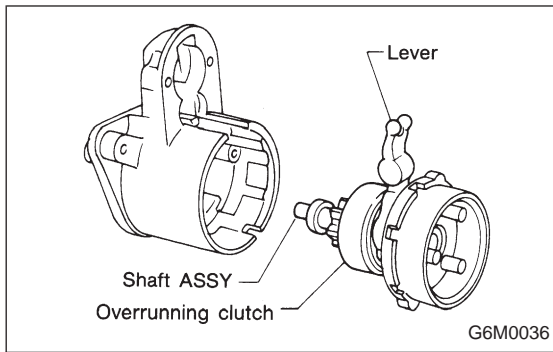

6) Remove shaft assembly and overrunning clutch as a unit.

CAUTION:

Record the direction of lever before removing.

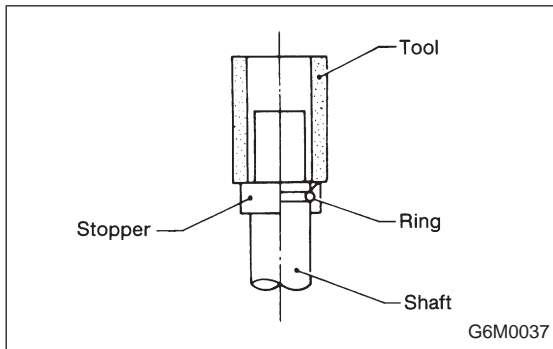

7) Remove overrunning clutch from shaft assembly as follows:

- (1) Remove stopper from ring by lightly tapping a fit tool placed on stopper.
- (2) Remove ring, stopper and clutch from shaft.

D: INSPECTION

1. ARMATURE

1) Check commutator for any sign of burns or rough surfaces or stepped wear. If wear is of a minor nature, correct it by using sand paper.

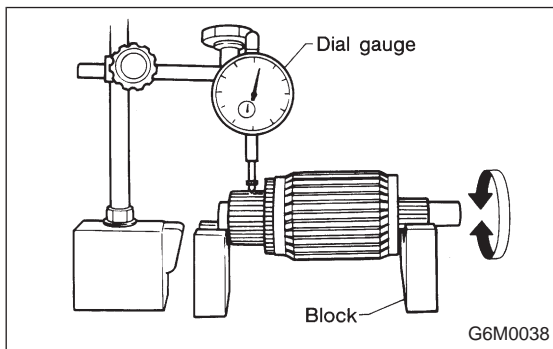

2) Run-out test

Check the commutator run-out and replace if it exceeds the limit.

Commutator run-out:

Standard

0.05 mm (0.0020 in)

Service limit

Less than 0.10 mm (0.0039 in)

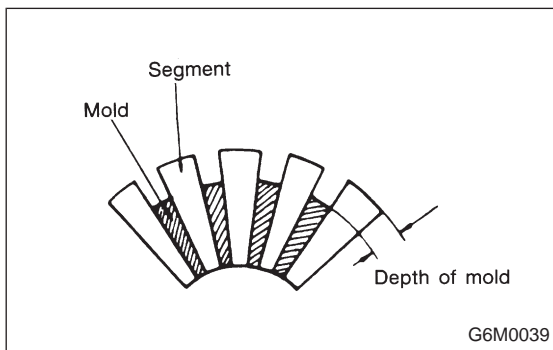

3) Depth of segment mold

Check the depth of segment mold.

Depth of segment mold:

0.5 — 0.8 mm (0.020 — 0.031 in)

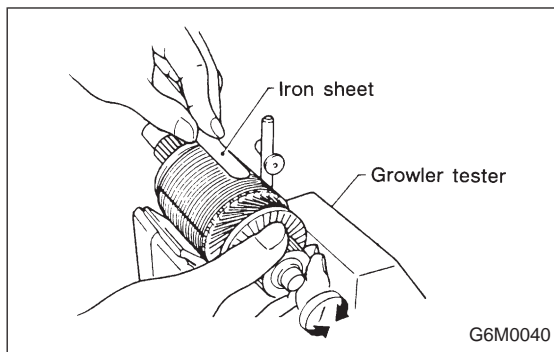

4) Armature short-circuit test

Check armature for short-circuit by placing it on growler tester. Hold a hacksaw blade against armature core while slowly rotating armature. A short-circuited armature will cause the blade to vibrate and to be attracted to core. If the hacksaw blade is attracted or vibrates, the armature, which is short-circuited, must be replaced or repaired.

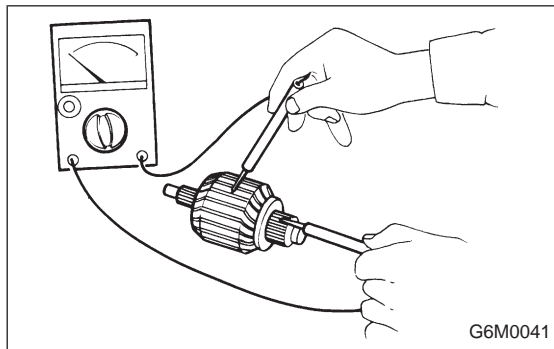

5) Armature ground test

Using circuit tester, touch one probe to the commutator segment and the other to shaft. There should be no continuity. If there is a continuity, armature is grounded. Replace armature if it is grounded.

2. YOKE

Make sure pole is set in position.

3. OVERRUNNING CLUTCH

Inspect teeth of pinion for wear and damage. Replace if it damaged. Rotate pinion in direction of rotation (clockwise). It should rotate smoothly. But in opposite direction, it should be locked.

CAUTION:

Do not clean overrunning clutch with oil to prevent grease from flowing out.

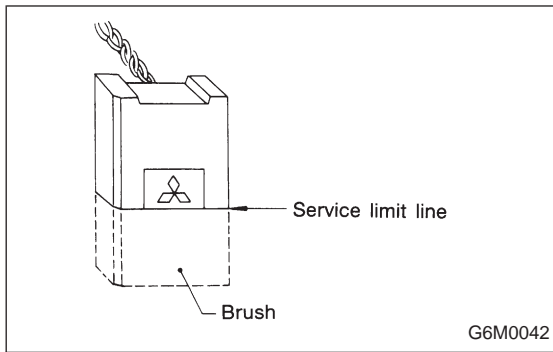

4. BRUSH AND BRUSH HOLDER

1) Brush length

Measure the brush length and replace if it exceeds the service limit.

Replace if abnormal wear or cracks are noticed.

Brush length:

Standard **17.0 mm (0.669 in)**

Service limit **11.5 mm (0.453 in)**

2) Brush movement

Be sure brush moves smoothly inside brush holder.

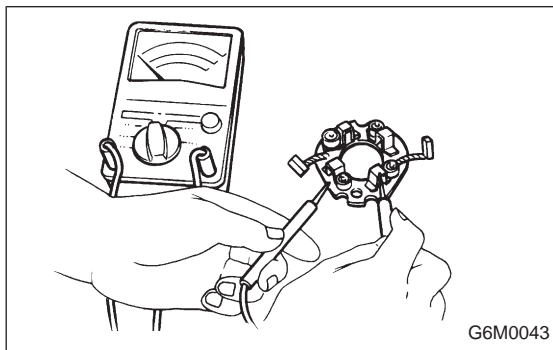

3) Insulation resistance of brush holder

Be sure there is no continuity between brush holder and its plate.

4) Brush spring force

Measure brush spring force with a spring scale. If it is less than the service limit, replace brush spring.

Brush spring force:

Standard

18.6 N (1.9 kg, 4.2 lb) (when new)

Service limit

6.9 N (0.7 kg, 1.5 lb)

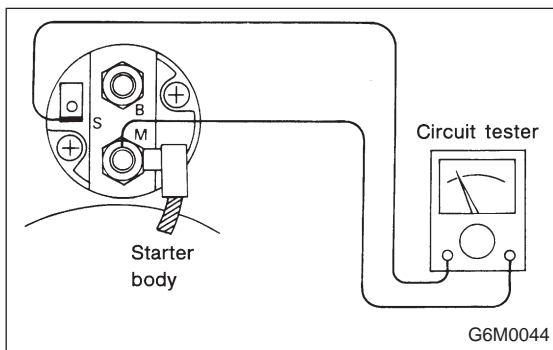

5. SWITCH ASSEMBLY

Be sure there is continuity between terminals S and M, and between terminal S and ground. Use a circuit tester (set in "ohm").

Also check to be sure there is no continuity between terminal M and B.

Terminal / Specified resistance:

S — M / 10 Ω, max.

S — Ground / 10 Ω, max.

M — B / 1 MΩ, min.

E: ASSEMBLY

Assembly is in the reverse order of disassembly procedures. Observe the following:

- 1) Carefully assemble all parts in the order of assembly and occasionally inspect nothing has been overlooked.
- 2) Apply grease to the following parts during assembly.
 - Front bracket sleeve bearing
 - Armature shaft gear
 - Outer periphery of plunger
 - Mating surface of plunger and lever
 - Gear shaft splines
 - Mating surface of lever and clutch
 - Ball at the armature shaft end
 - Internal and planetary gears
- 3) After assembling parts correctly, check to be sure starter operates properly.