

12. Condenser

A: REMOVAL AND INSTALLATION

- 1) Disconnect battery negative terminal.
- 2) Discharge refrigerant from low-pressure side.
- 3) Remove front grille.

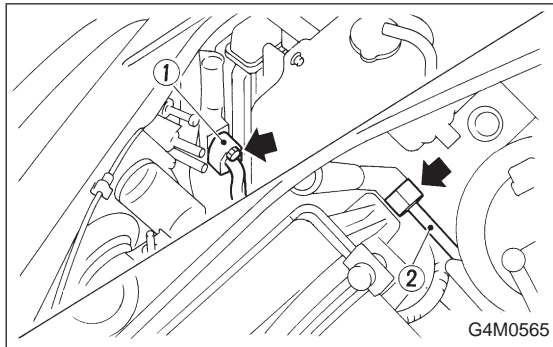

- 4) Remove the radiator bracket.
- 5) Disconnect high-pressure hose ① and high-pressure pipe ② from condenser.

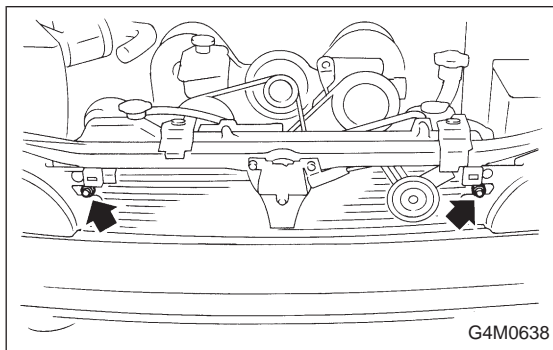

- 6) Remove the two bolts which secure condenser. While lifting condenser, remove it through space between radiator and radiator panel.

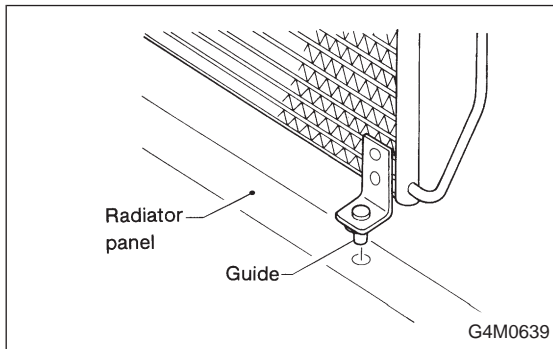

- 7) The condenser should be installed in the reverse order in which it was removed. When installing the condenser, pay attention to the following:

CAUTION:

Before connecting the pipe, be sure to apply oil to the periphery of O-ring.

NOTE:

After installing condenser, ensure that guide on lower side of condenser is inserted into hole in radiator panel. Tighten attaching bolts.

B: INSPECTION

1) Make sure the condenser fins are free from dust and insects. If the fins are clogged, clean by blowing air or water through them.

NOTE:

To prevent dust and water from getting into the condenser, this work must be done when the condenser is installed in an actual vehicle.

2) Check the condenser to see if it shows any sign of oil seepage. Should oil ooze or gas leak from the condenser replace it with a new one.

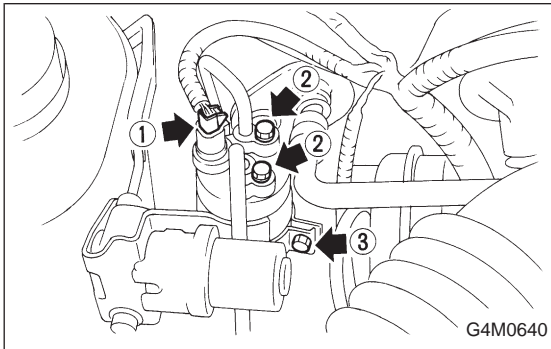
**13. Receiver Drier****A: REMOVAL AND INSTALLATION**

- 1) Disconnect battery negative terminal.
- 2) Discharge refrigerant.
- 3) Disconnect pressure switch harness ①.
- 4) Disconnect pipes ②.
- 5) Remove mounting bolt ③ and remove receiver drier.

CAUTION:

The receiver drier contains a desiccant. Be sure to put a blind plug in the detached receiver drier to protect it from moisture.

- 6) Install the receiver drier in the reverse order of removal.