

1. Front Axle

A: REMOVAL

- 1) Disconnect ground cable from battery.
- 2) Jack-up vehicle, support it with safety stands, and remove front wheels.

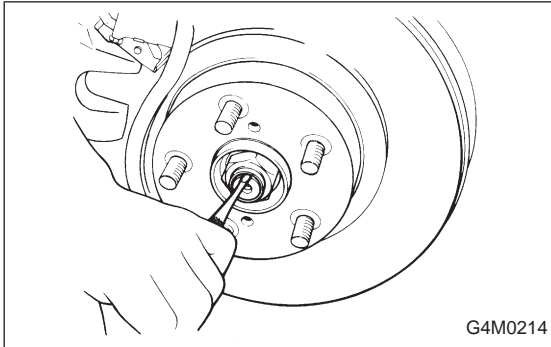

- 3) Unlock axle nut.
- 4) Remove axle nut using a socket wrench.

CAUTION:

Be sure to loose and retighten axle nut after removing wheel from vehicle. Failure to follow this rule may damage wheel bearings.

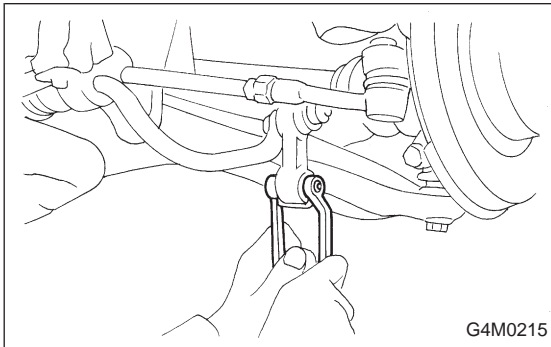

- 5) Remove stabilizer link.

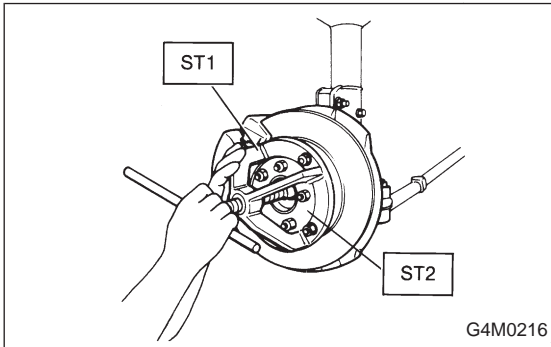

- 6) Remove DOJ from transmission spindle.
- 7) Remove front drive shaft assembly from hub. If it is hard to remove, use STs.

ST1 926470000 AXLE SHAFT PULLER
ST2 927140000 PLATE

CAUTION:

- Be careful not to damage oil seal lip when removing front drive shaft.
- When replacing front drive shaft, also replace inner oil seal.

- 8) Remove disc brake caliper from housing, and suspend it from strut using a wire.

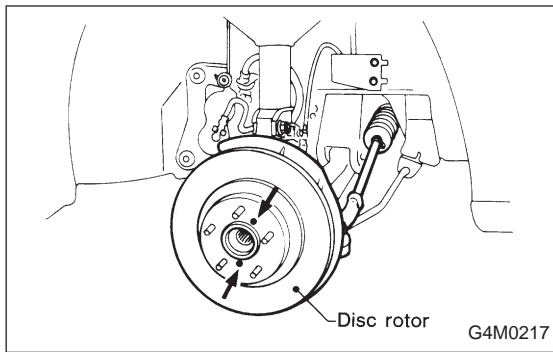

9) Remove disc rotor from hub.
If disc rotor seizes up within hub, drive disc rotor out by installing an 8-mm bolt in screw hole on the rotor.

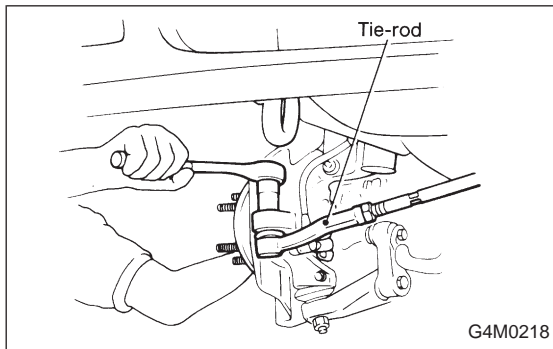

10) Remove cotter pin and castle nut which secure tie-rod end to housing knuckle arm.

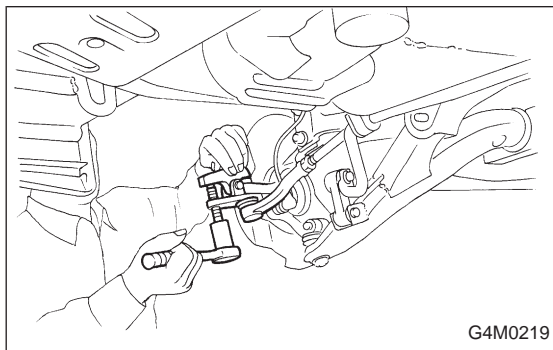

11) Using a puller, remove tie rod ball joint from knuckle arm.

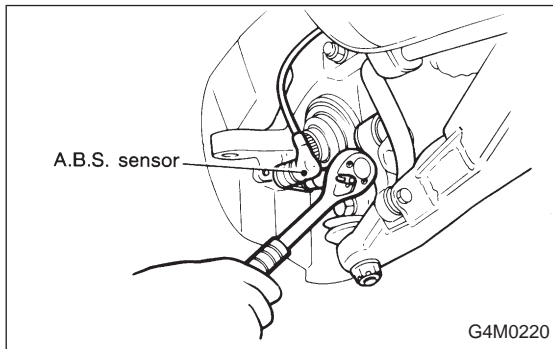

12) On A.B.S. equipped models, remove A.B.S. sensor assembly and harness in advance.

NOTE:

Be sure to use soft jaws (such as aluminum plates) when placing the mating surfaces of housing and strut in a vise.

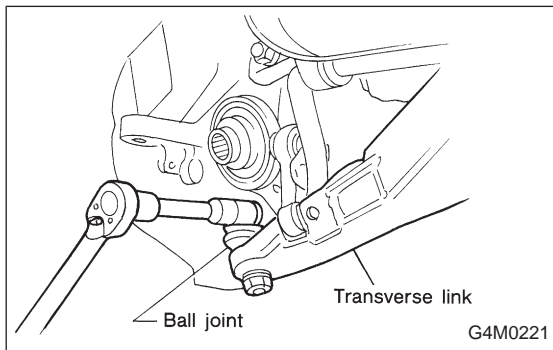

13) Remove transverse link ball joint from housing.

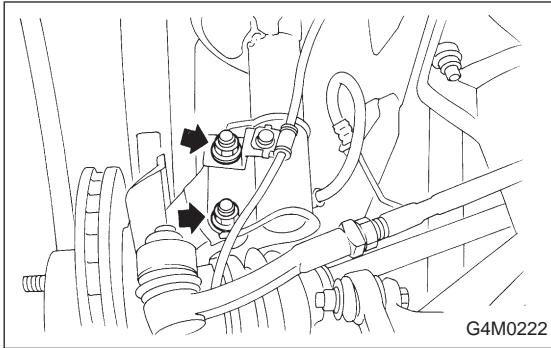

14) After scribing an alignment mark on camber adjusting bolt head, remove bolts which connect housing and strut, and disconnect housing from strut.

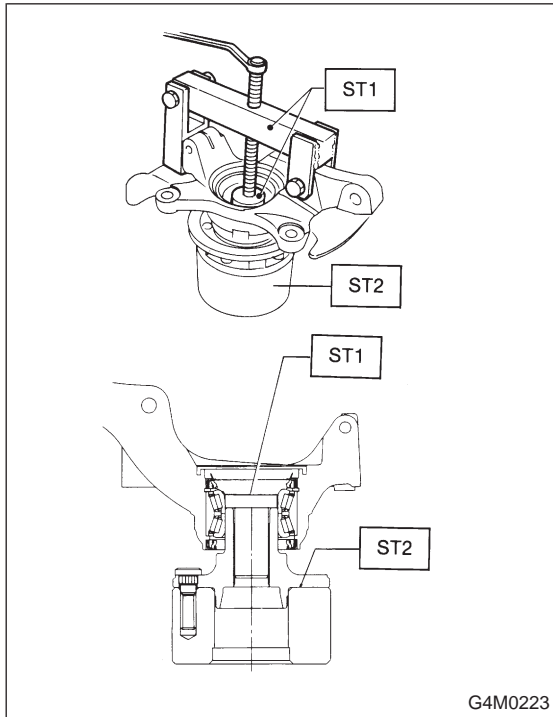

B: DISASSEMBLY

- 1) Using ST1, support housing and hub securely.
- 2) Attach ST2 to housing and drive hub out.

ST1 927080000 HUB STAND
ST2 927060000 HUB REMOVER

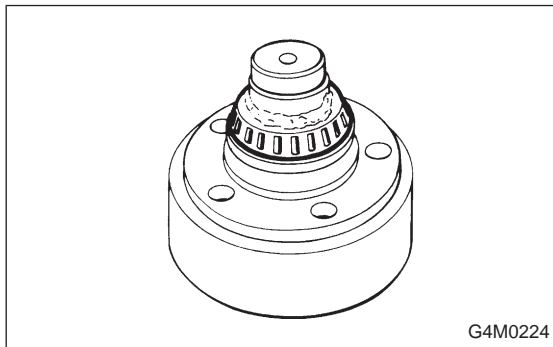

If inner bearing race remains in the hub, remove it with a suitable tool (commercially available).

CAUTION:

- Be careful not to scratch polished area of hub.
- Be sure to install inner race on the side of outer race from which it was removed.

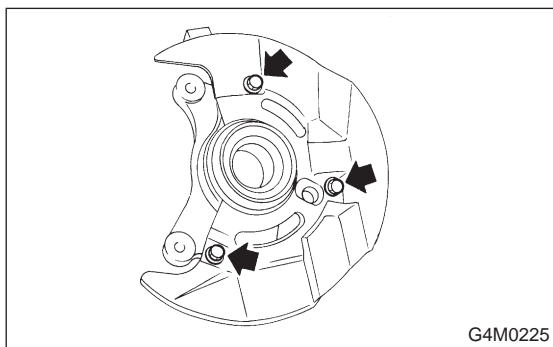

- 3) Remove disc cover from housing.
- 4) Using a standard screwdriver, remove outer and inner oil seals.

CAUTION:

Do not use old oil seals.

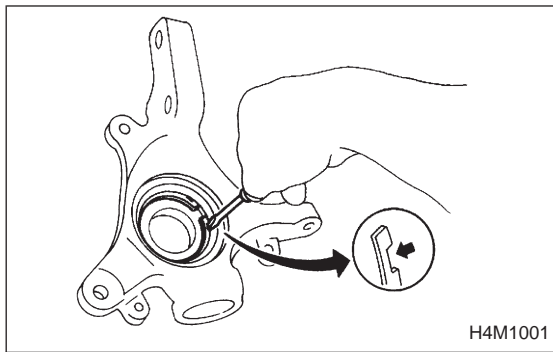

5) Using flat bladed screwdriver, remove snap ring.

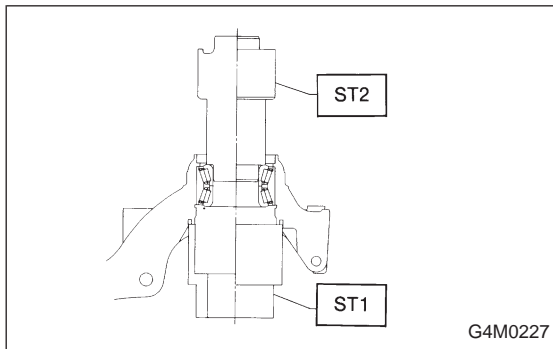

6) Using ST1, support housing securely.

7) Using ST2, press inner race to drive out outer bearing.

ST1 927400000 HOUSING STAND

ST2 927100000 BEARING REMOVER

CAUTION:

- Do not remove outer race unless it is faulty.
- Discard outer race after removal.
- Do not replace inner or outer race separately; always replace as a unit.

8) Loosen bolts which secure tone wheel to hub. Remove tone wheel (only vehicle equipped with A.B.S.).

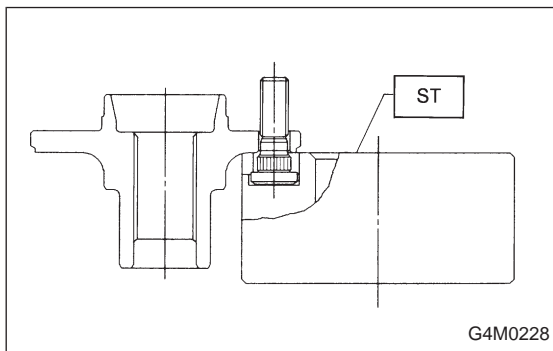

9) Using ST and a hydraulic press, drive hub bolts out.

ST 927080000 HUB STAND

CAUTION:

Be careful not to hammer hub bolts. This may deform hub.

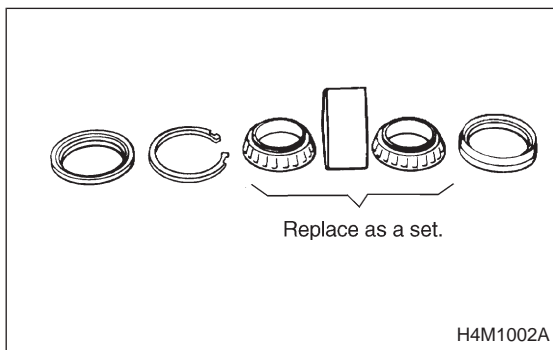

C: INSPECTION

Check the removed parts for wear and damage. If defective, replace with a new one.

CAUTION:

- If bearing is faulty, replace it as the bearing set.
- Be sure to replace oil seal at every overhaul.

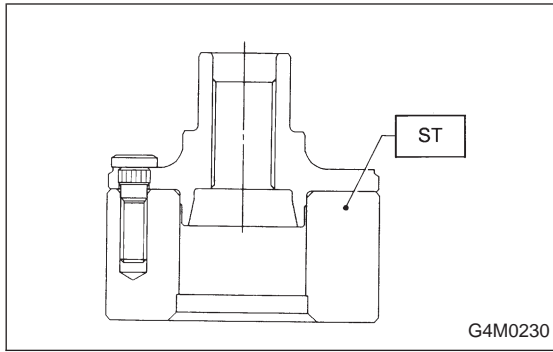
**D: ASSEMBLY**

1) Attach hub to ST securely.

ST 927080000 HUB STAND

2) Using a hydraulic press, press new hub bolts into place.

CAUTION:

Be sure to press hub bolts until their seating surfaces contact the hub.

NOTE:

Use 12 mm (0.47 in) dia. holes in HUB STAND to prevent bolts from tilting.

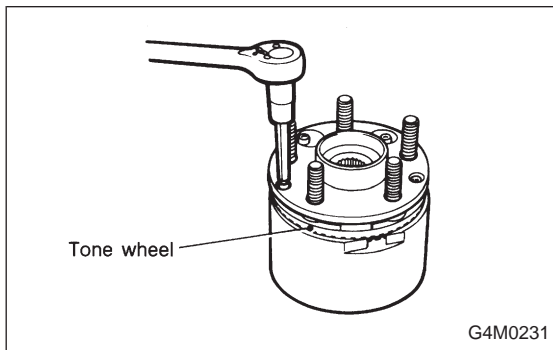

3) Remove foreign particles (dust, rust, etc.) from mating surfaces of hub and tone wheel, and install tone wheel to hub (only vehicle equipped with A.B.S.).

CAUTION:

Be careful not to damage tone wheel teeth.

NOTE:

Ensure tone wheel closely contacts hub.

4) Clean dust or foreign particles from inside the housing.

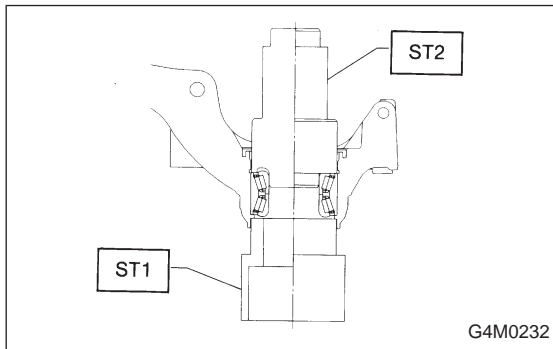

5) Using ST1 and ST2, press a new bearing into place.

ST1 927400000 HOUSING STAND

ST2 927100000 BEARING REMOVER

CAUTION:

- Always press outer race when installing bearing.
- Be careful not to remove plastic lock from inner race when installing bearing.
- Charge bearing with new grease when outer race is not removed.

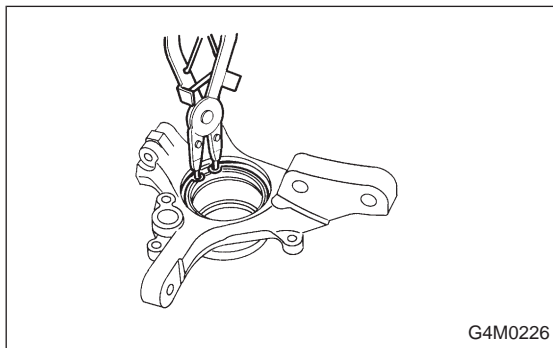

6) Using pliers, install snap ring in its groove.

CAUTION:

Make sure to install it firmly to groove.

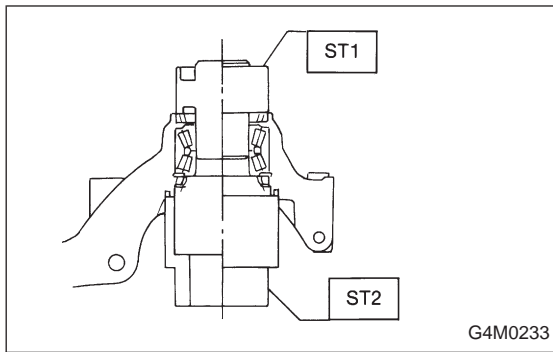

7) Using ST1 and ST2, press outer oil seal until it contacts the bottom of housing.

ST1 927410000 OIL SEAL INSTALLER
ST2 927400000 HOUSING STAND

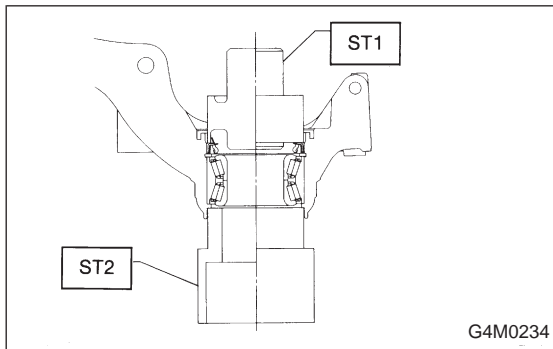

8) Using ST1 and ST2, press inner oil seal until it contacts circlip.

ST1 927410000 OIL SEAL INSTALLER
ST2 927400000 HOUSING STAND

9) Invert ST and housing.

ST 927400000 HOUSING STAND

10) Apply sufficient grease to oil seal lip.

Specified grease

SHELL 6459N

CAUTION:

- If specified grease is not available, remove bearing grease and apply Auto Rex A instead.
- Do not mix different types of grease.

11) Install disc cover to housing the three bolts.

Tightening torque:

14±4 N·m (1.4±0.4 kg·m, 10.1±2.9 ft·lb)

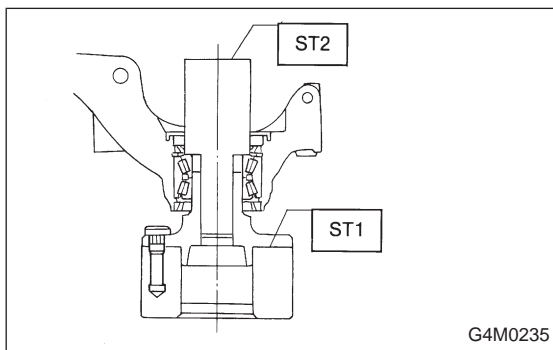

12) Attach hub to ST1 securely.

13) Clean dust or foreign particles from the polished surface of hub.

14) Using ST2, press bearing into hub by driving inner race.

ST1 927080000 HUB STAND
ST2 927120000 HUB INSTALLER

E: INSTALLATION

1) Install transverse link ball joint to housing.

Tightening torque:

44 ± 6 N·m (4.5 ± 0.6 kg·m, 32.5 ± 4.3 ft·lb)

2) While aligning alignment mark on camber adjusting bolt head, connect housing and strut.

CAUTION:

Use a new self-locking nut.

Tightening torque:

147 ± 15 N·m (15 ± 1.5 kg·m, 108 ± 11 ft·lb)

3) Install speed sensor and harness on housing (only vehicle equipped with A.B.S.).

4) Install disc rotor on hub.

5) Install disc brake caliper on housing.

Tightening torque:

59 ± 10 N·m (6 ± 1 kg·m, 43 ± 7 ft·lb)

6) Install front drive shaft. <Ref. to 4-2 [W4E1].>

7) Connect stabilizer link.

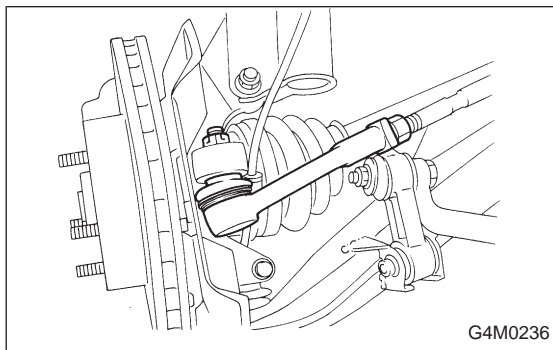

8) Install tie-rod end ball joint on housing knuckle arm.

Tightening torque:

27.0 ± 2.5 N·m (2.75 ± 0.25 kg·m, 19.9 ± 1.8 ft·lb)

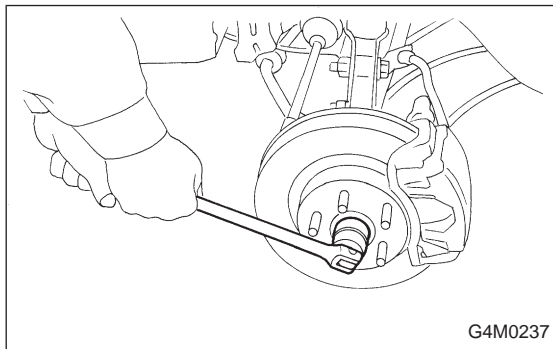

9) While depressing brake pedal, tighten axle nut and lock it securely.

Tightening torque:

186 ± 20 N·m (19 ± 2 kg·m, 137 ± 14 ft·lb)

CAUTION:

- Use a new axle nut.
- Always tighten axle nut before installing wheel on vehicle. If wheel is installed and comes in contact with ground when axle nut is loose, wheel bearings may be damaged.
- Be sure to tighten axle nut to specified torque. Do not overtighten it as this may damage wheel bearing.

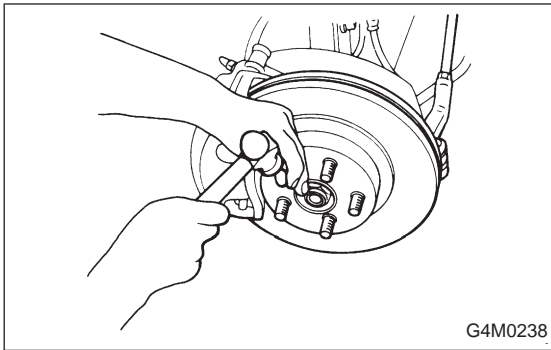

- 10) After tightening axle nut, lock it securely.
- 11) Install wheel and tighten wheel nuts to specified torque.

Tightening torque:

88 ± 10 N·m (9 ± 1 kg-m, 65 ± 7 ft-lb)

2. Rear Axle (AWD Model)

A: REMOVAL

- 1) Disconnect ground cable from battery.
- 2) Jack-up vehicle, and remove rear wheel cap and wheels.

CAUTION:

Be sure to loosen and retighten axle nut after removing wheel from vehicle. Failure to follow this rule may damage wheel bearings.

- 3) Unlock axle nut.
- 4) Remove axle nut using a socket wrench.

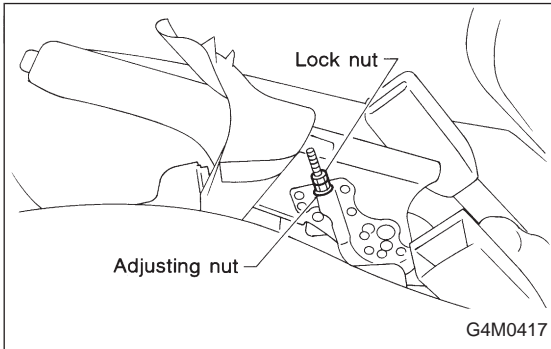

- 5) Return parking brake lever and loosen adjuster.
 - (1) Disc brake: Perform steps 6) and 7).
 - (2) Drum brake: Perform steps 8) and 10).

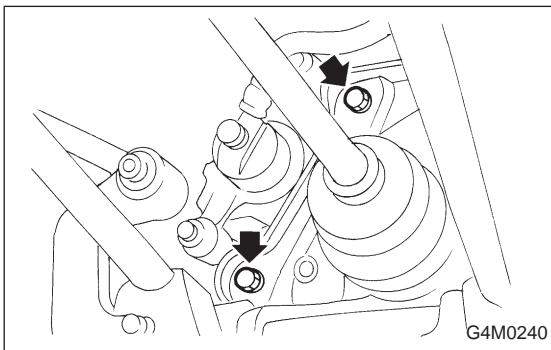

- 6) Remove disc brake caliper from back plate, and suspend it from strut using a piece of wire.
- 7) Remove disc rotor from hub.

NOTE:

If disc rotor seizes up within hub, drive it out by installing an 8-mm bolt into bolt hole in disc rotor.