

Drum brake: Perform steps 9) through 11).

9) Clean brake pipe connection. Using a flare-nut wrench, connect brake pipe to wheel cylinder.

10) Connect parking brake cable to lever.

11) Install brake drum on rear housing assembly.

12) Bleed air from brake system. <Ref. to 4-4 [W11B0].>

13) Adjust parking brake lever stroke by turning adjuster.

14) Move brake lever back to apply brakes. While depressing brake pedal, tighten axle nut using a socket wrench. Lock axle nut after tightening.

Tightening torque:

186±20 N·m (19±2 kg-m, 137±14 ft-lb)

CAUTION:

- Use a new axle nut.
- Always tighten axle nut before installing wheel on vehicle. If wheel is installed and comes in contact with ground when axle nut is loose, wheel bearings may be damaged.

- Be sure to tighten axle nut to specified torque. Do not overtighten it as this may damage wheel bearing.

15) Install wheel and tighten wheel nuts to specified torque.

Tightening torque:

88±10 N·m (9±1 kg-m, 65±7 ft-lb)

3. Rear Axle (FWD Model)

A: REMOVAL

1) Disconnect ground cable from battery.

2) Jack-up vehicle, and remove rear wheel cap and wheels.

CAUTION:

Be sure to loosen and retighten axle nut after removing wheel from vehicle. Failure to follow this rule may damage wheel bearings.

3) Pry hub cap off with a screwdriver placed between it and hub.

4) Unlock axle nut.

5) Remove axle nut using a socket wrench. Remove washer.

CAUTION:

Do not re-use old axle nut. Replace with a new one.

NOTE:

Temporarily tighten axle nut to hold hub in place.

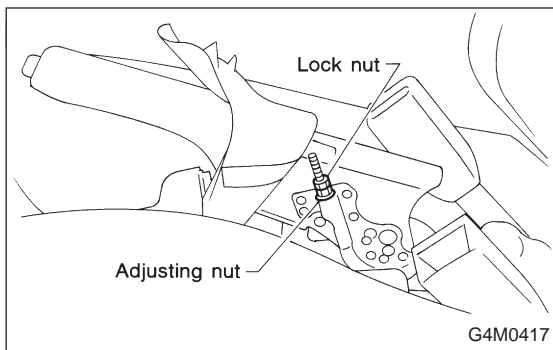

- 6) Return parking brake lever and loosen adjuster.
- (1) Disc brake: Perform steps 7) through 9).
 - (2) Drum brake: Perform steps 10) through 13).

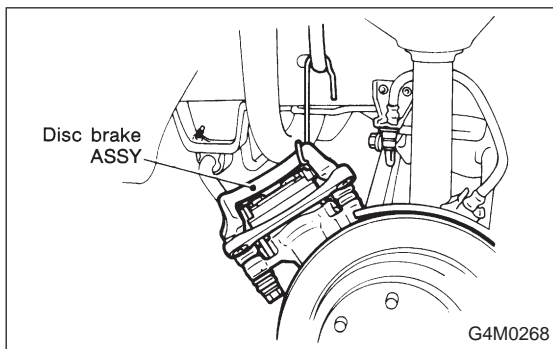

- 7) Remove disc brake assembly from back plate. Suspend disc brake assembly from strut using a wire.

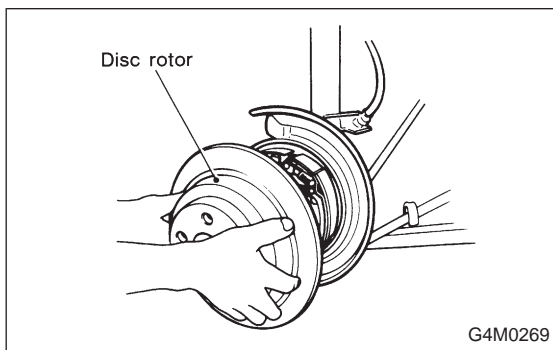

- 8) Remove disc rotor from hub.
If disc rotor seizes up within hub, drive it out by installing an 8-mm bolt in bolt hole on disc rotor.
- 9) Disconnect end of parking brake cable.

- 10) Remove brake drum from hub.

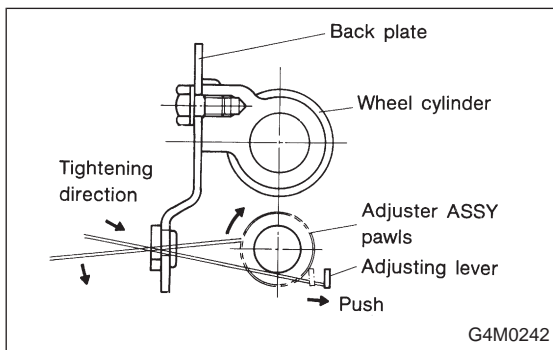

- 11) If it is difficult to remove brake drum, remove adjusting hole cover from back plate, and then turn adjusting screw using a slot-type screwdriver until brake shoe separates from the drum.

3. Rear Axle (FWD Model)

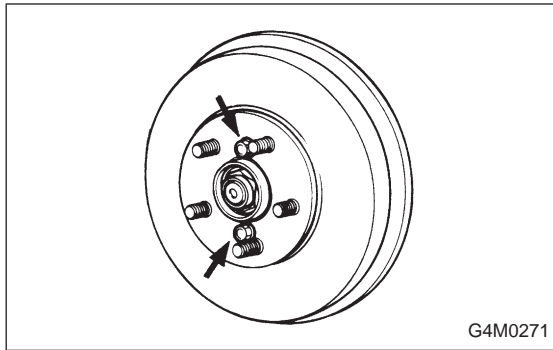
**NOTE:**

If brake drum seizes up within hub, drive it out by installing an 8-mm bolt in bolt hole on brake drum.

12) Disconnect end of parking brake cable.

13) Using a flare-nut wrench, disconnect brake pipe from wheel cylinder.

CAUTION:

Cover brake pipe connection to prevent entry of foreign particles.

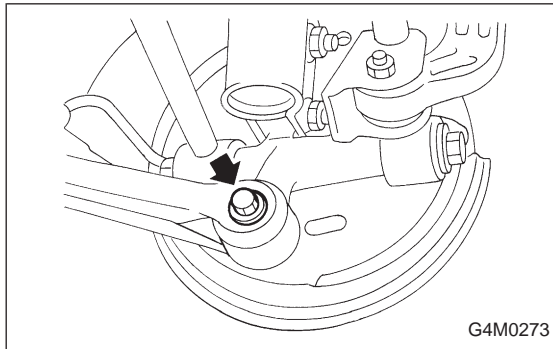

14) Remove bolts which secure trailing link assembly to rear spindle.

CAUTION:

Discard old self-locking nut. Replace with a new one.

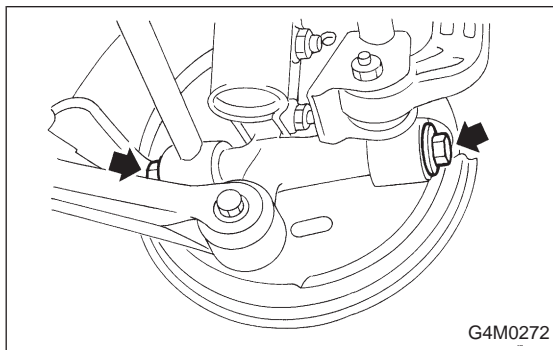

15) Remove bolts which secure lateral link assembly to rear spindle.

CAUTION:

Discard old self-locking nut. Replace with a new one.

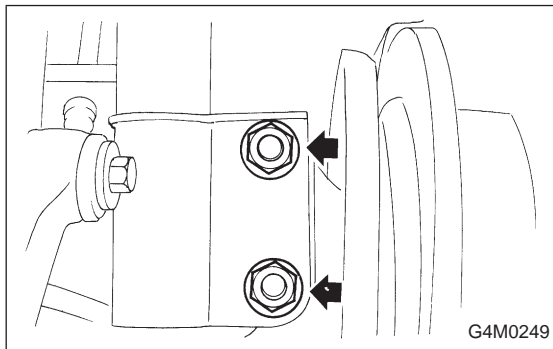

16) Remove bolts which secure strut assembly to rear spindle.

Remove rear spindle, back plate and hub as a unit.

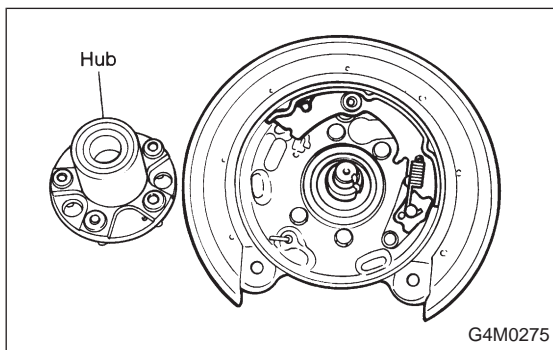
**B: DISASSEMBLY**

1) Remove hub from rear spindle.

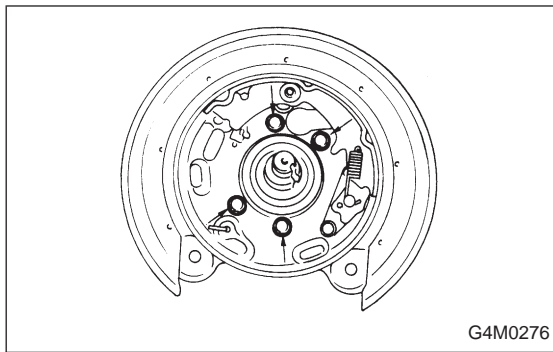

2) Remove back plate from rear spindle.

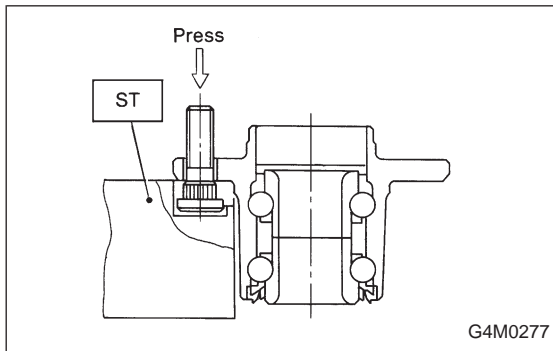

3) Using ST, press hub bolts out.

CAUTION:

Do not hammer hub bolt since this may deform hub.

ST 927080000 HUB STAND

C: INSPECTION

Clean the removed parts and check them for wear, damage and corrosion. If faulty, replace.

CAUTION:

Hub unit cannot be disassembled. If faulty, replace it as a unit.

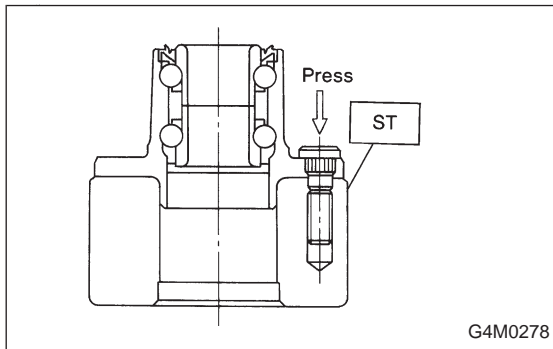

D: ASSEMBLY

1) Using ST, press new hub bolts into place.

NOTE:

- Use a 12 mm (0.47 in) hole in ST to prevent hub bolt from tilting during installation.
- Ensure hub bolt closely contacts hub.

ST 927080000 HUB STAND

2) Completely clean dust or dirt from the mating/polished surface of rear spindle back plate.

3) Install back plate to rear spindle.

Tightening torque:

52±6 N·m (5.3±0.6 kg-m, 38.3±4.3 ft-lb)

4) Charge oil seal located on the rear of hub with grease.

Specified grease:

SHELL 6459N

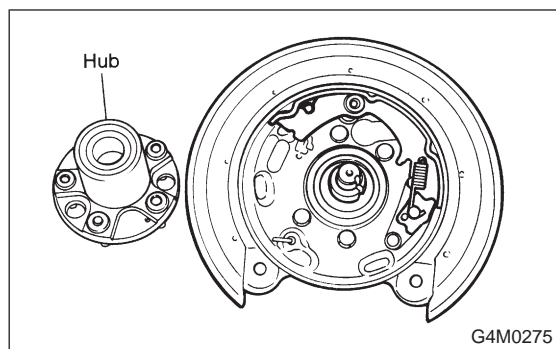

5) Install hub on rear spindle. Temporarily tighten axle nut and washer to hold hub in place.

CAUTION:

Discard old axle nut. Replace with a new one.

E: INSTALLATION

1) Connect rear spindle assembly to strut assembly.

Tightening torque:

147 ± 15 N·m (15 ± 1.5 kg·m, 108 ± 11 ft·lb)

CAUTION:

Use a new self-locking nut.

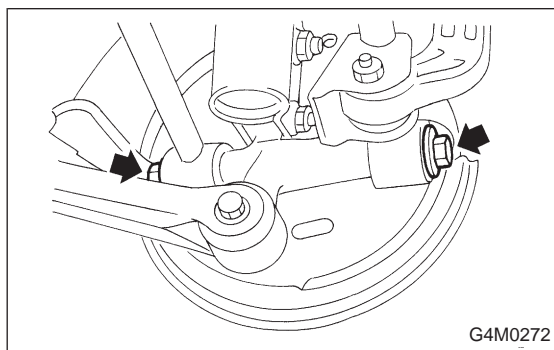

2) Connect rear spindle assembly to lateral link assembly.

Tightening torque:

137 ± 20 N·m (14 ± 2 kg·m, 101 ± 14 ft·lb)

CAUTION:

Use new self-locking nut.

3) Connect rear spindle assembly to trailing link assembly.

Tightening torque:

113 ± 15 N·m (11.5 ± 1.5 kg·m, 83 ± 11 ft·lb)

CAUTION:

Use a new self-locking nut.

Disc brake: Perform steps 4) through 6).

4) Connect end of parking brake cable.

5) Install disc rotor to hub unit.

6) Install disc brake assembly to back plate.

Tightening torque:

52 ± 6 N·m (5.3 ± 0.6 kg·m, 38.3 ± 4.3 ft·lb)

Drum brake: Perform steps 7) through 10).

7) Completely clean brake pipe connection. Using a flare-nut wrench, connect brake pipe to wheel cylinder.

8) Connect parking brake cable to lever.

9) Install brake drum on hub unit.

10) Bleed air from brake system. <Ref. to 4-4 [W11B0].>

11) Tighten axle nut using a socket wrench, and lock securely.

Tightening torque: **186 ± 20 N·m (19 ± 2 kg·m, 137 ± 14 ft·lb)****CAUTION:**

- Use a new axle nut.
 - Always tighten axle nut before installing wheel on vehicle. If wheel is installed and comes in contact with ground when axle nut is loose, wheel bearings may be damaged.
 - Be sure to tighten axle nut to specified torque. Do not overtighten it as this may damage wheel bearing.
- 12) Install O-ring to hub cap flange, and install hub cap by lightly tapping it with a plastic-faced hammer.
- 13) Install wheel and tighten wheel nuts to specified torque.

Tightening torque (Wheel nut): **88 ± 10 N·m (9 ± 1 kg·m, 65 ± 7 ft·lb)****4. Front and Rear Drive Shafts****A: REMOVAL****1. FRONT DRIVE SHAFT**

- 1) Disconnect ground cable from battery.
- 2) Jack-up vehicle, support it with safety stands (rigid rocks), and remove front wheel cap and wheels.
- 3) Unlock axle nut.
- 4) Remove axle nut using a socket wrench.

CAUTION:

Be sure to loosen and retighten axle nut after removing wheel from vehicle. Failure to follow this rule may damage wheel bearings.

- 5) Disconnect transverse link from housing.

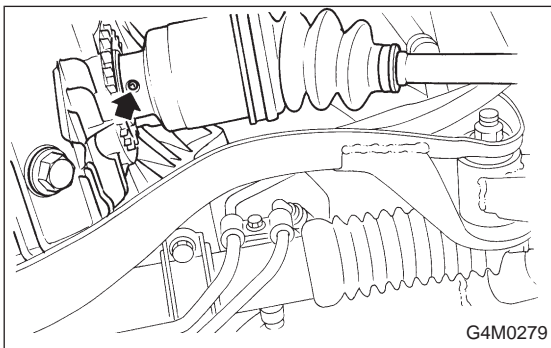

- 6) Remove spring pin which secures transmission spindle to DOJ.

CAUTION:

Use a new spring pin.