

1. Torque Converter Clutch and Case

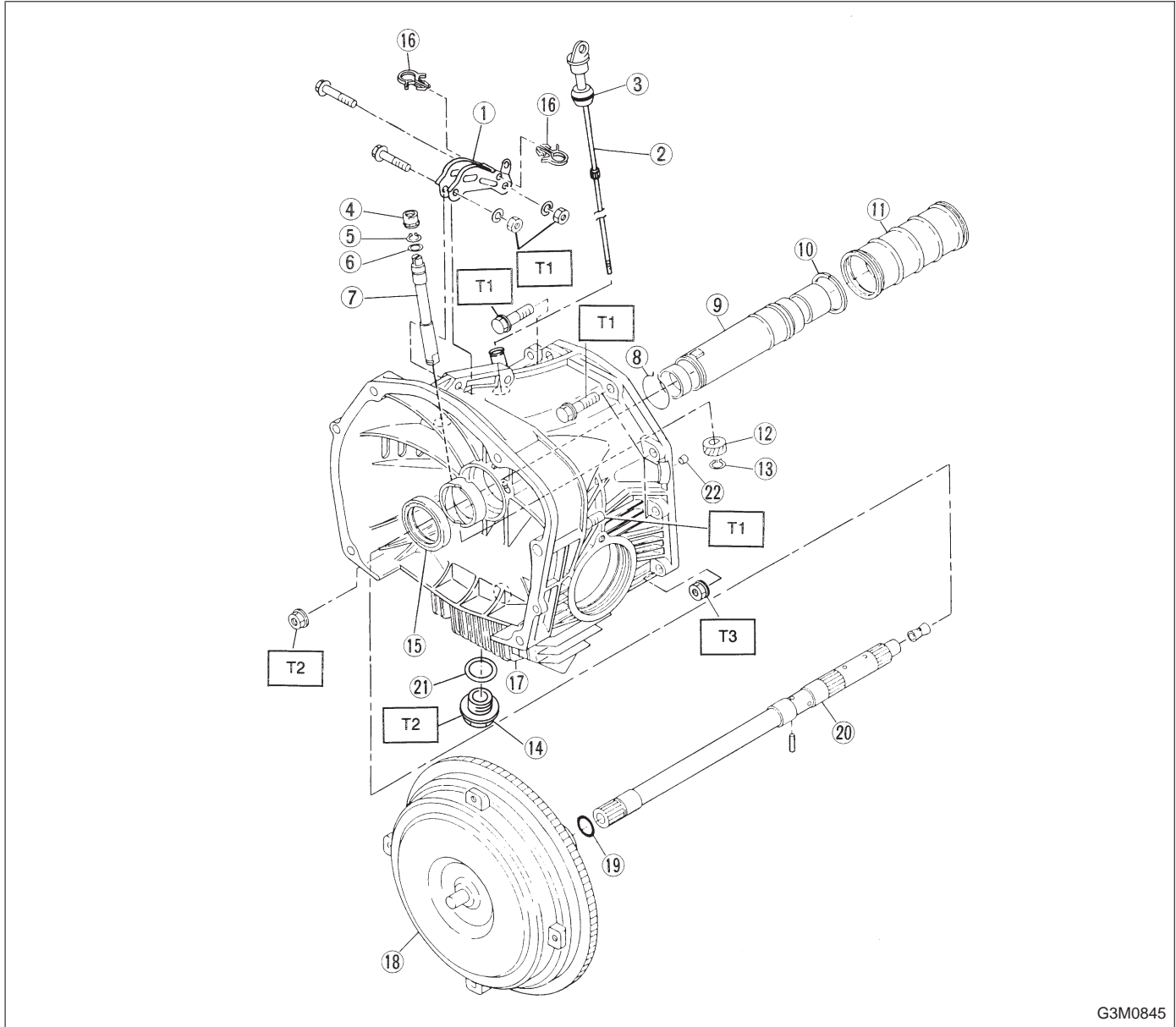

G3M0845

- ① Pitching stopper bracket
- ② Oil level gauge
- ③ O-ring
- ④ Oil seal
- ⑤ Snap ring
- ⑥ Washer
- ⑦ Speedometer shaft
- ⑧ Clip
- ⑨ Oil pump shaft
- ⑩ Seal ring
- ⑪ Seal pipe
- ⑫ Speedometer driven gear
- ⑬ Snap ring
- ⑭ Drain plug

- ⑮ Oil seal
- ⑯ Air breather hose clip
- ⑰ Torque converter clutch case
- ⑱ Torque converter clutch
- ⑲ O-ring
- ⑳ Input shaft
- ㉑ Gasket
- ㉒ Oil drain pipe

Tightening torque: N·m (kg·m, ft·lb)**T1: 18±5 (1.8±0.5, 13.0±3.6)****T2: 41±3 (4.2±0.3, 30.4±2.2)****T3: 44±3 (4.5±0.3, 32.5±2.2)**