

3. Oil Pump

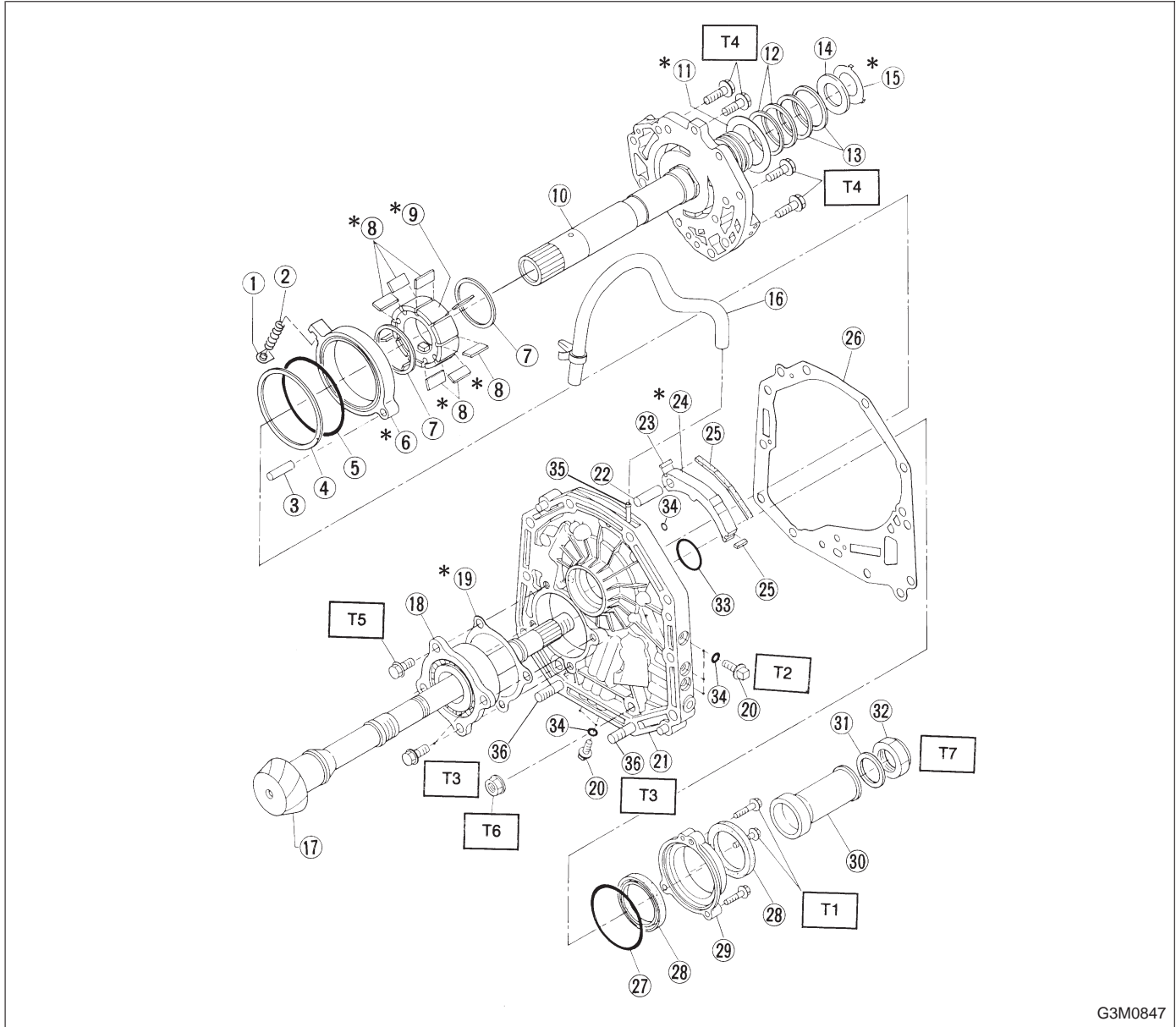

G3M0847

- |                         |                       |
|-------------------------|-----------------------|
| ① Retainer              | ⑳ Oil pump housing    |
| ② Return spring         | ㉑ Pin                 |
| ③ Pin                   | ㉒ Side seal           |
| ④ Friction ring         | ㉓ Control piston      |
| ⑤ O-ring                | ㉔ Plane seal          |
| ⑥ Cam ring              | ㉕ Gasket              |
| ⑦ Vane ring             | ㉖ O-ring              |
| ⑧ Vane                  | ㉗ Oil seal            |
| ⑨ Rotor                 | ㉘ Oil seal retainer   |
| ⑩ Oil pump cover        | ㉙ Drive pinion collar |
| ⑪ Thrust washer         | ㉚ Lock washer         |
| ⑫ Seal ring (R)         | ㉛ Lock nut            |
| ⑬ Seal ring (H)         | ㉜ O-ring              |
| ⑭ Thrust needle bearing | ㉝ O-ring              |
| ⑮ Thrust washer         | ㉞ Nipple              |
| ⑯ Air breather hose     | ㉟ Stud bolt           |
| ⑰ Drive pinion shaft    |                       |
| ⑱ Roller bearing        |                       |
| ㉒ Shim                  |                       |
| ㉓ Test plug             |                       |

**Tightening torque: N·m (kg·m, ft·lb)**

T1: 7±1 (0.7±0.1, 5.1±0.7)

T2: 13±1 (1.3±0.1, 9.4±0.7)

T3: 18±5 (1.8±0.5, 13.0±3.6)

T4: 25±2 (2.5±0.2, 18.1±1.4)

T5: 39±3 (4.0±0.3, 28.9±2.2)

T6: 41±3 (4.2±0.3, 30.4±2.2)

T7: 113±5 (11.5±0.5, 83.2±3.6)