

2. On-Car Service

A: INSPECTION

1. ATF LEVEL

1) Raise ATF temperature to 60 to 80°C (140 to 176°F) from 40 to 60°C (104 to 140°F) (when cold) by driving a distance of 5 to 10 km (3 to 6 miles).

NOTE:

The level of ATF varies with fluid temperature. Pay attention to the fluid temperature when checking oil level.

2) Ensure the vehicle is level. After selecting all positions (P, R, N, D, 3, 2, 1), set the selector lever in "P" range. Measure fluid level with the engine idling.

NOTE:

After running, idle the engine for one or two minutes before measurement.

3) If the fluid level is below the center between upper and lower marks, add the recommended ATF until the fluid level is found within the specified range (above the center between upper and lower marks). When the transmission is hot, the level should be above the center of upper and lower marks, and when it is cold, the level should be found below the center of these two marks.

CAUTION:

- Use care not to exceed the upper limit level.
- ATF level varies with temperature. Remember that the addition of fluid to the upper limit mark when the transmission is cold will result in the overfilling of fluid.

4) Fluid temperature rising speed

- By idling the engine
 - Time for rising temperature to 60°C (140°F) with atmospheric temperature of 0°C (32°F): More than 25 minutes (Reference)

Time for temperature rise to 30°C (86°F) with atmospheric temperature of 0°C (32°F): Approx. 8 minutes

- By running the vehicle
 - Time for temperature rise to 60°C (140°F) with atmospheric temperature of 0°C (32°F): More than 10 minutes

5) Method for checking fluid level upon delivery or at periodic inspection.

Check fluid level after a warm-up run of approx. 10 minutes. During the warm-up period, the automatic transmission functions can also be checked.

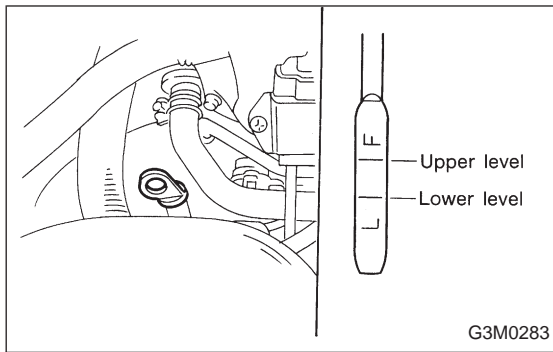

2. DIFFERENTIAL GEAR OIL LEVEL

1) Ensure the vehicle

NOTE:

Do not check the oil level nor add oil to the case with the front end of the vehicle jacked up; this will result in an incorrect reading of the oil level.

2) Check whether the oil level is between the upper (F) and lower (L) marks. If it is below the lower limit mark, add oil until the level reaches the upper mark.

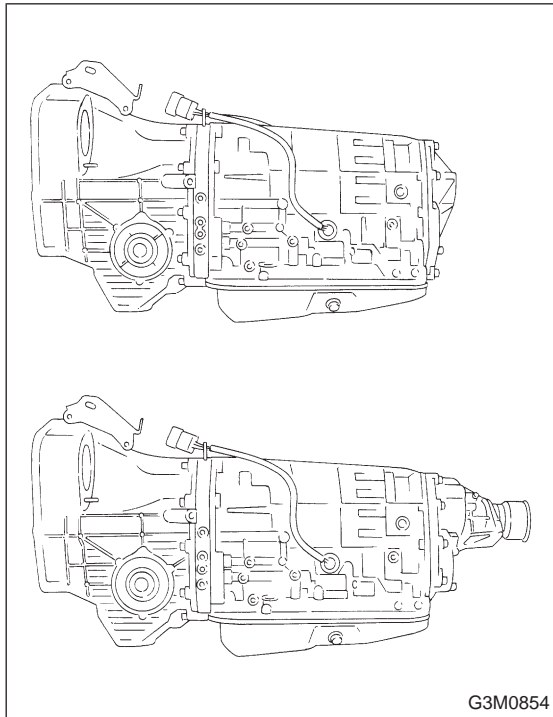

3. OIL LEAKAGE

It is difficult to accurately determine the precise position of a oil leak, since the surrounding area also becomes wet with oil. The places where oil seals and gaskets are used are as follows:

<Jointing portion of the case>

- Transmission case and oil pump housing jointing portion
- Torque converter clutch case and oil pump housing jointing portion
- Transmission case and transmission cover jointing portion (FWD)
- Transmission case and extension case jointing portion (AWD)

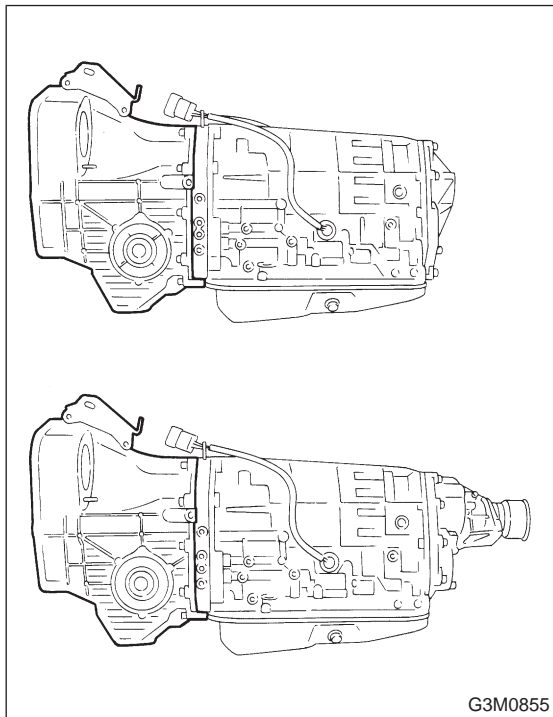

Torque converter clutch case

- Engine crankshaft oil seal
- Torque converter clutch impeller sleeve oil seal
- ATF cooler pipe connector
- Torque converter clutch
- Torque converter clutch case
- Axle shaft oil seal
- O-ring on the outside diameter of axle shaft oil seal holder
- O-ring on the differential oil gauge
- Differential oil drain plug
- Speedometer cable mounting portion
- Location of steel balls

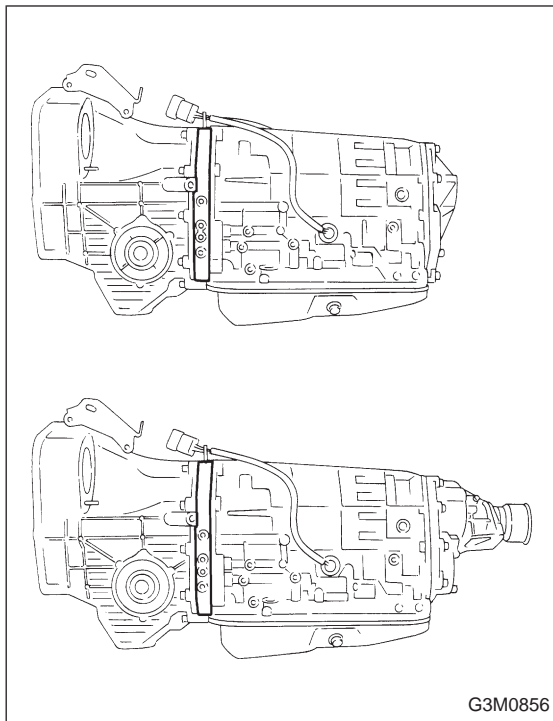

Oil pump housing

- Oil pump housing (Defective casting)
- O-ring on the test plugs
- Checking blind plugs
- Differential gear breather

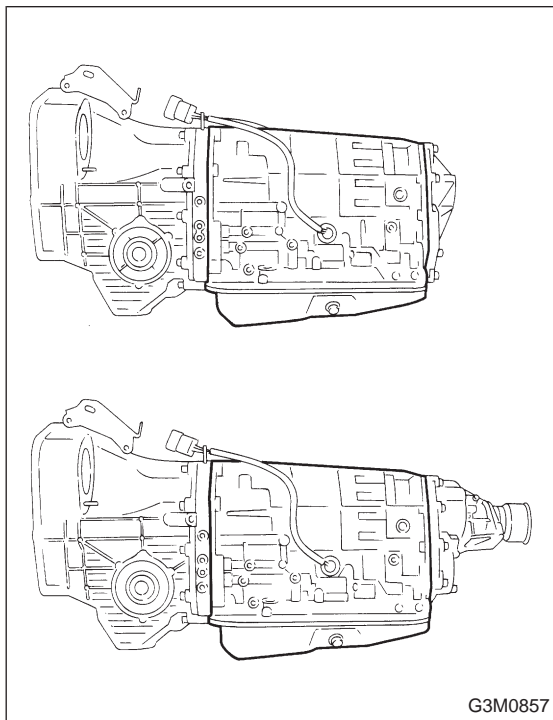

Automatic transmission case

- Transmission case (Defective casting)
- Mating surface of oil pan
- O-ring on the test plugs
- Checking blind plugs (Steel balls)
- Oil supply pipe connector
- ATF cooler pipe connector and gasket
- Oil pan drain plug
- O-ring on the transmission harness holder
- Oil pump plugs
- ATF breather
- Shift lever oil seal

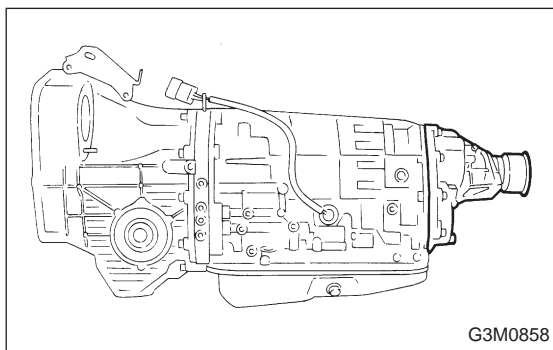

Extension case

- Extension case (Defective casting)
- O-ring on the vehicle speed sensor
- Rear drive shaft oil seal
- Checking blind plugs (Steel ball)
- O-ring on the test plugs

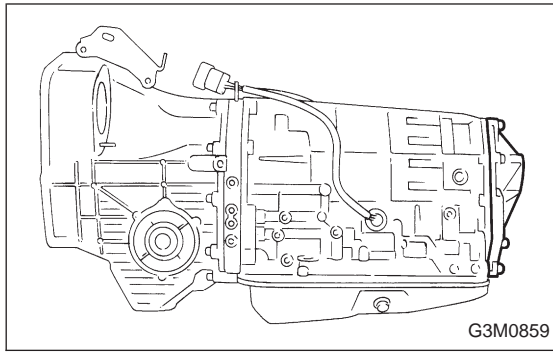

Transmission cover

● Transmission cover (Defective casting)

The point listed above should be checked for fluid leak.

Checking method is as follows:

- (1) Place the vehicle in the pit, and check whether the leaking oil is ATF or not. The ATF is wine red in color, and can be discriminated easily from engine oil and gear oil.
- (2) Wipe clean the leaking oil and dust from a suspectable area, using a nonflammable organic solvent such as carbon tetrachloride.
- (3) Run the engine to raise the fluid temperature, and set the selector lever to “D” in order to increase the fluid pressure and quickly detect a leaking point. Also check for fluid leaks while shifting select lever to “R”, “2”, and “1”.

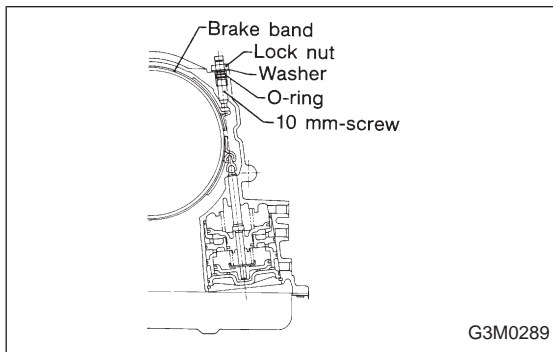

B: ADJUSTMENT

1. BRAKE BAND

If the following abnormal shifting conditions are noted in a road test, the brake band must be adjusted.

Improper brake band clearances and their symptoms	
Clearance	Problem
1. Too wide	Upshift from 1st directly to 3rd gear occurs.
2. Wide	<ul style="list-style-type: none"> ● Engine rpm increases abruptly while upshifting from 1st to 2nd gear or 3rd to 4th gear. ● Time lag of at least one second occurs during kickdown operation from 3rd to 2nd gear.
3. Small	“Braking” symptom occurs while upshifting from 2nd to 3rd gear.
4. Too small	Upshifts from 2nd to 4th gear and downshifts from 4th to 2nd gear occur repeatedly.

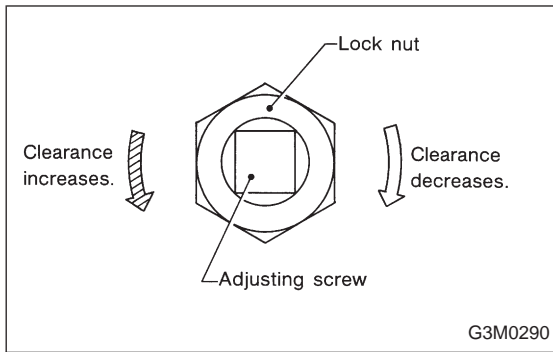

● Adjustment of the adjusting screw

1) Using a ST, immobilize the end of the 10 mm screw projecting on the left side of the transmission case, and loosen the nut with a double-end wrench.

In the case of occurrence of problems 1) and 2) mentioned previously, perform the adjustment by loosening or tightening the nut within a range of 3/4 turn from this state.

ST 398603610 SOCKET WRENCH

CAUTION:

Do not loosen excessively; otherwise, the band strut on the servo piston will drop off.

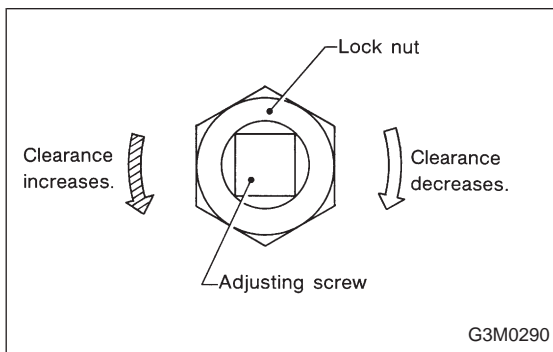

2) In case of the occurrence of problems 1 and 4 mentioned previously, perform the adjustment as follows:

Adjusting procedure: Tighten adjust screw to 9 N·m (0.9 kg-m, 6.5 ft-lb) torque, then back off three turns.

CAUTION:

Do not tighten the adjusting screw with an excessively large torque.

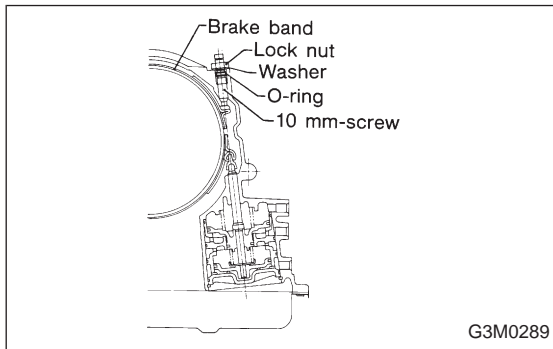

3) With the adjusting screw immobilized, tighten the lock nut.

Tightening torque:

26±2 N·m (2.7±0.2 kg-m, 19.5±1.4 ft-lb)

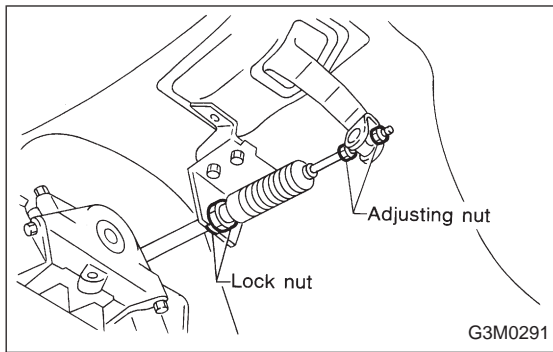

2. INHIBITOR SWITCH

The inhibitor switch allows the back-up lights to turn on when the select lever is in the R range and the starter motor to start when the lever is in the N or P range. It also monitors the input signal electronically controlled for each range and turns on the corresponding range light on the instrument panel.

When light operation, driving condition or starter motor operation is erroneous, first check the shift linkage for improper operation. If the shift linkage is functioning properly, check the inhibitor switch.

<Inspection>

- (1) Disconnect cable end from select lever.
- (2) Disconnect inhibitor switch connector.
- (3) Check continuity in inhibitor switch circuits with select lever moved to each position.

CAUTION:

Also check that continuity in ignition circuit does not exist when selector lever is in R, D, 3, 2 and 1 ranges.

Pin No.	4	3	2	1	8	7	6	5	12	11	10	9
Lead color	B	Y	Br	YG	W	BY	R	GW	BY	BW	BW	RW
Position												
P	○	○							○	○		
R	○		○								○	○
N	○			○					○	○		
D	○				○							
3	○					○						
2	○						○					
1	○							○				
	Signal sent to AT control module								Ignition circuit		Back-up light circuit	

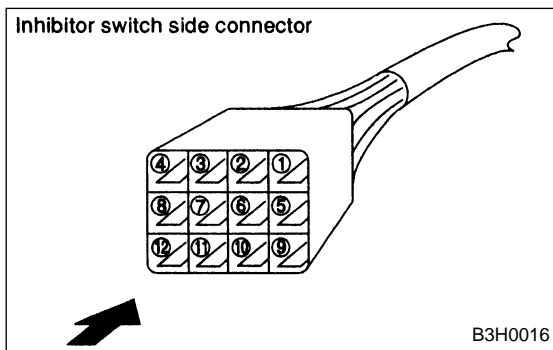

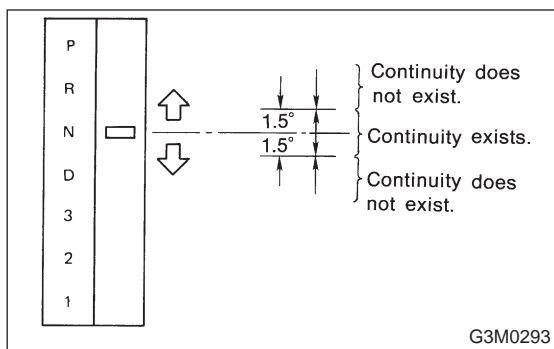

(4) Check if there is continuity at equal points when the select lever is turned 1.5° in both directions from the N range.

If there is continuity in one direction and the continuity in the other or if there is continuity at unequal points, adjust the inhibitor switch.

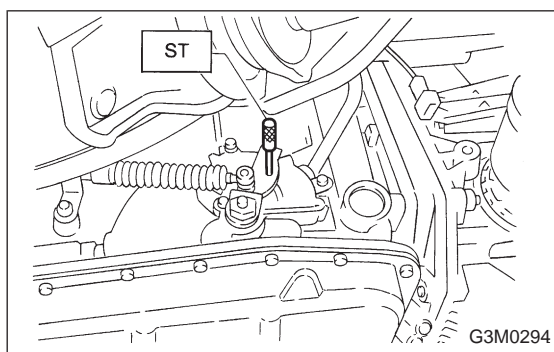

<Adjustment>

- (1) Loosen the three inhibitor switch securing bolts.
- (2) Shift the select lever to the N range.
- (3) Insert ST as vertical as possible into the holes in the inhibitor switch lever and switch body.

ST 499267300 STOPPER PIN

- (4) Tighten the three inhibitor switch bolts.

Tightening torque:

$3.4 \pm 0.5 \text{ N}\cdot\text{m}$ ($0.35 \pm 0.05 \text{ kg}\cdot\text{m}$, $2.5 \pm 0.4 \text{ ft}\cdot\text{lb}$)

- (5) Repeat the above checks. If the inhibitor switch is determined to be "faulty", replace it.

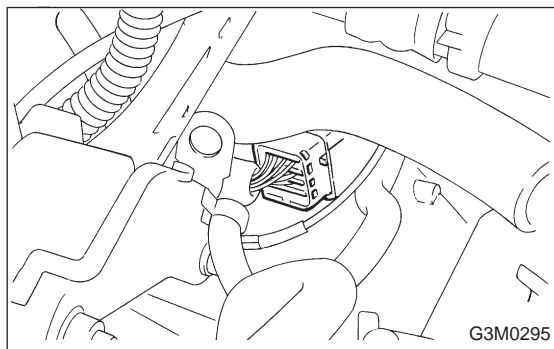

3. SENSOR (IN TRANSMISSION)

- 1) Check each sensor, solenoid and ground system for short circuits.

4. STANDARD VALUES

Part name	Terminal	Resistance (Ω)
Vehicle speed sensor 1	9 — 16	450 — 650
ATF temperature sensor	5 — 12	100 — 6,000 [2,000/20°C (68°F)]
Duty solenoid A (Line pressure solenoid)	7 — 4, 8	2.0 — 4.5
Duty solenoid B (Lock-up solenoid)	6 — 4, 8	10 — 17
Shift solenoid 1	3 — 4, 8	20 — 30
Shift solenoid 2	2 — 4, 8	20 — 30
Shift solenoid 3	1 — 4, 8	20 — 30
Duty solenoid C (AWD only) (Transfer clutch solenoid)	11 — 4, 8	10 — 17

NOTE:

If part is faulty, its resistance value will be different from the standard value indicated above.

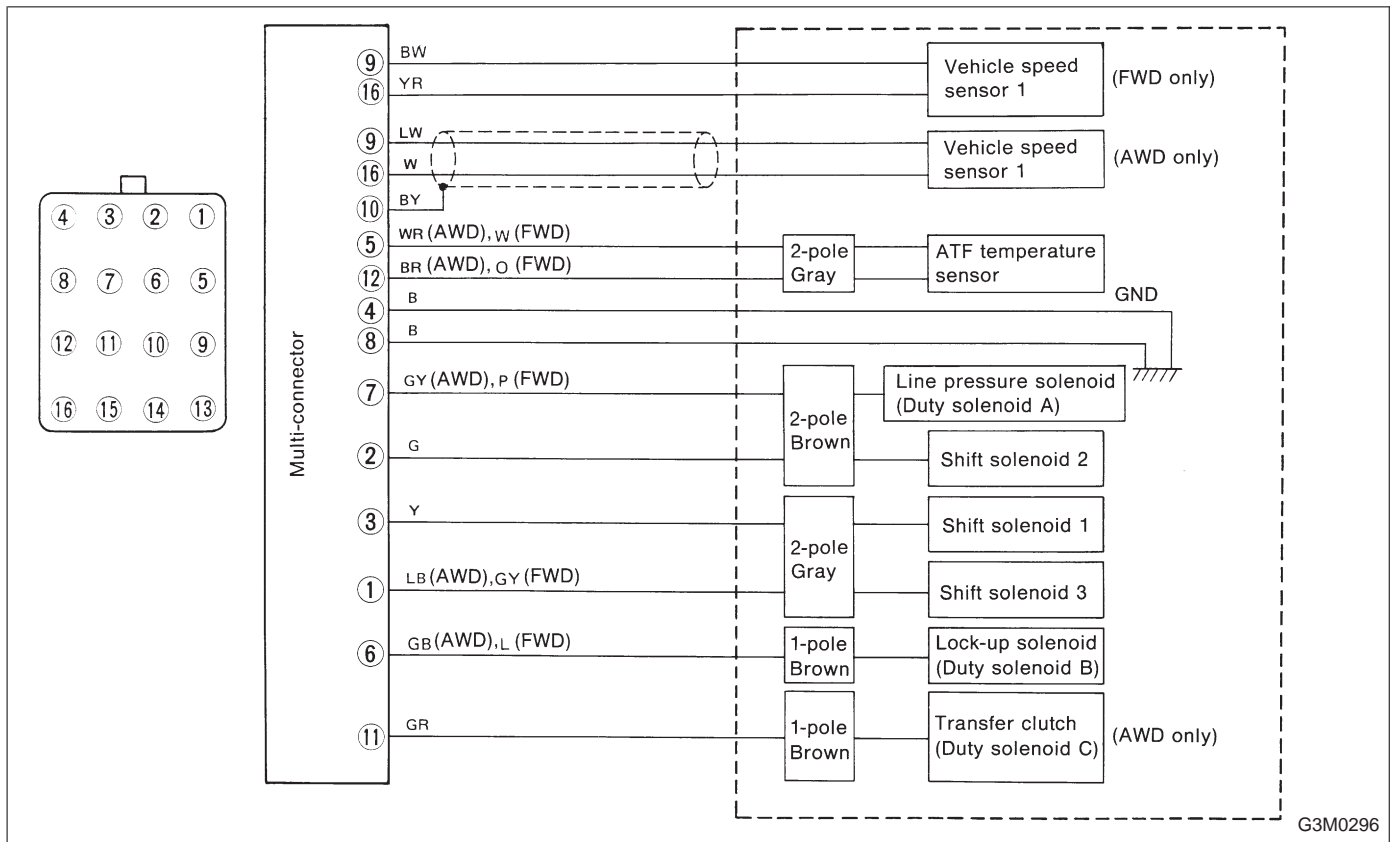

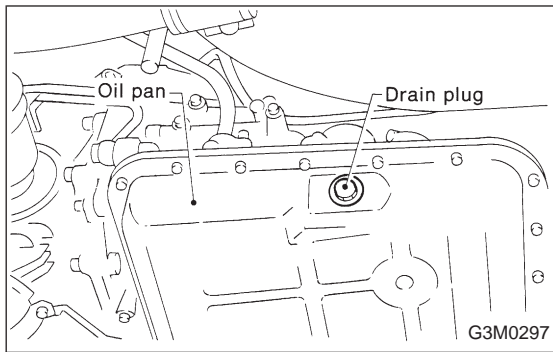

C: REMOVAL AND INSTALLATION

1. SHIFT SOLENOID, DUTY SOLENOID AND VALVE BODY

1) Removal

- (1) Clean transmission exterior.
- (2) Drain ATF completely.

NOTE:

Tighten ATF drain plug after draining ATF.

Tightening torque:

25±2 N·m (2.5±0.2 kg·m, 18.1±1.4 ft·lb)

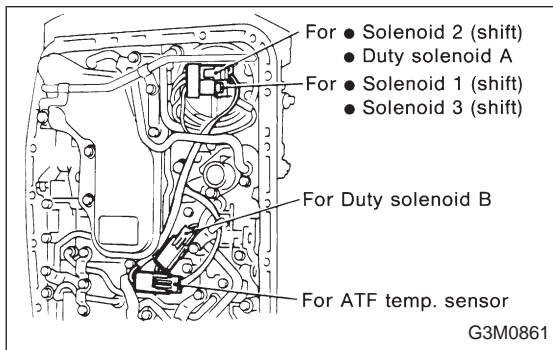

- (3) Remove oil pan and gasket.

NOTE:

Drain oil into a container.

- (4) Disconnect solenoid valve connectors. Remove connectors from clips and disconnect connectors at 4 places.

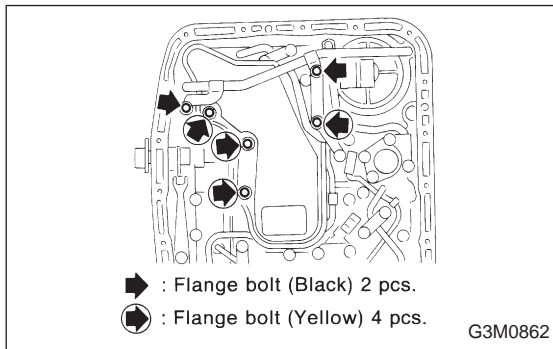

- (5) Remove oil strainer.

Disconnect oil pipe by removing the two bolts, and remove four bolts and oil strainer.

NOTE:

Be careful because oil flows from oil strainer.

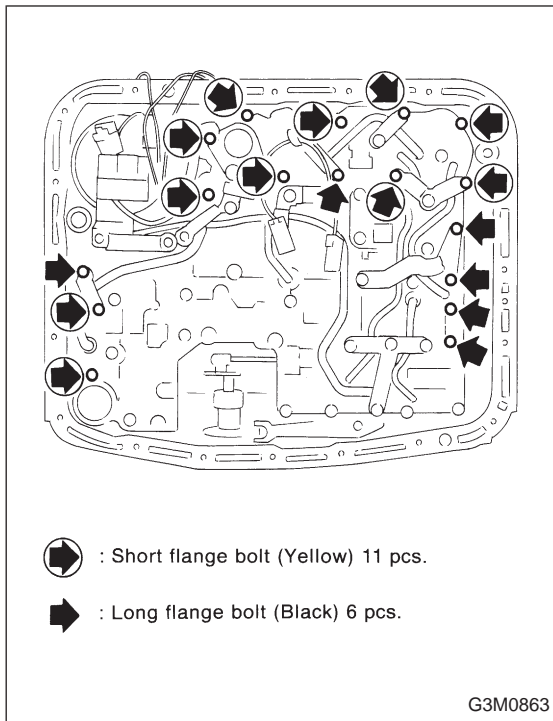

- (6) Remove control valve body and two brackets.
Remove 6 long bolts (Black) and 11 short bolts (Yellow).

NOTE:

- Be careful because oil flows from valve body.
- Be careful not to damage accumulator spring at rear of control valve.

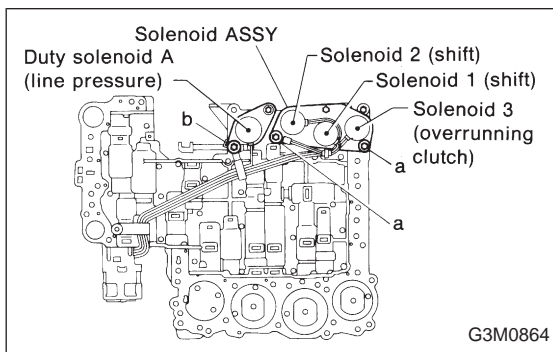

- (7) Remove shift solenoids 1, 2, and 3, and duty solenoid A.

a length: 16 mm (0.63 in)
b length: 27 mm (1.06 in)

- (8) Remove duty solenoid B (lock-up).

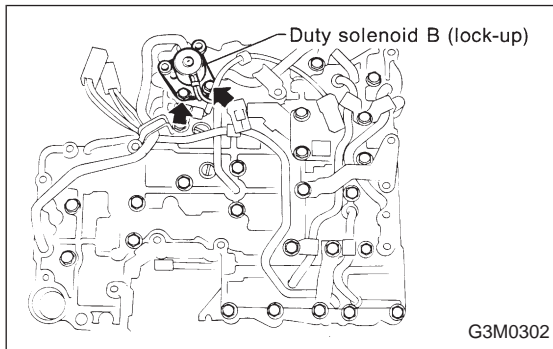

2) Installation

- (1) Install duty solenoid B (lock-up).

Tightening torque:

11.3±1.5 N·m (1.15±0.15 kg-m, 8.3±1.1 ft-lb)

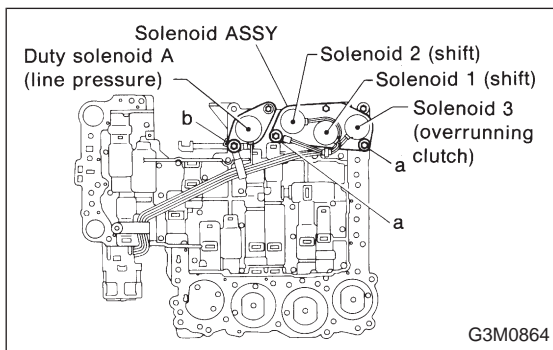

- (2) Install solenoid valves.

Shift solenoids, 1, 2 and 3, and duty solenoid A (line pressure).

Tightening torque:

8.3±1.5 N·m (0.85±0.15 kg-m, 6.1±1.1 ft-lb)

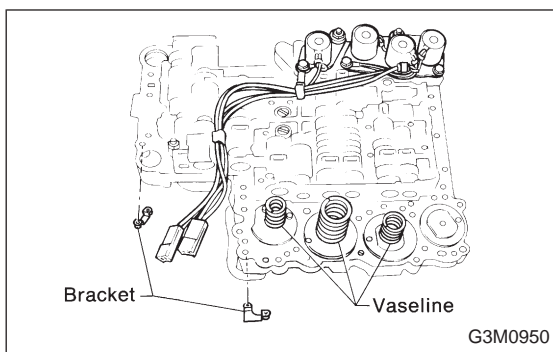

(3) Install valve body and two brackets.

Tightening torque:

8 ± 1 N·m (0.8 ± 0.1 kg·m, 5.8 ± 0.7 ft·lb)

NOTE:

- Secure accumulator springs using vaseline.
- Align manual valve connections.

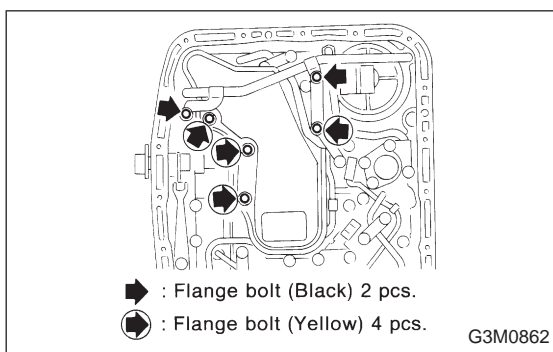

(4) Install oil strainer.

Also install oil pipe and harness connector bracket.

Tightening torque:

8 ± 1 N·m (0.8 ± 0.1 kg·m, 5.8 ± 0.7 ft·lb)

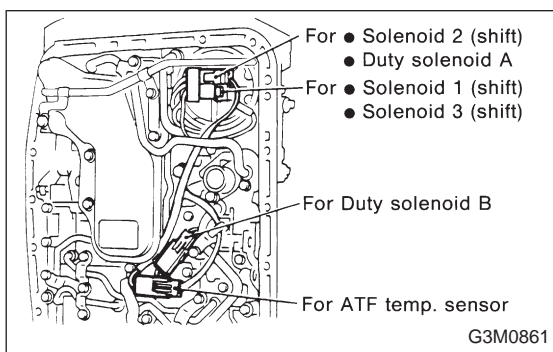

(5) Connect harness connectors at 4 places.

Connect connectors of same color, and secure connectors to valve body using clips.

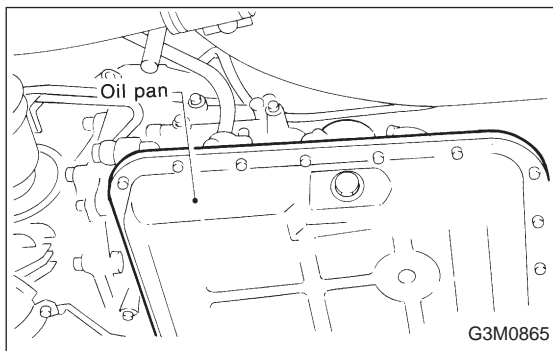

(6) Install oil pan and gasket.

Tightening torque:

4.9 ± 0.5 N·m (0.50 ± 0.05 kg·m, 3.6 ± 0.4 ft·lb)

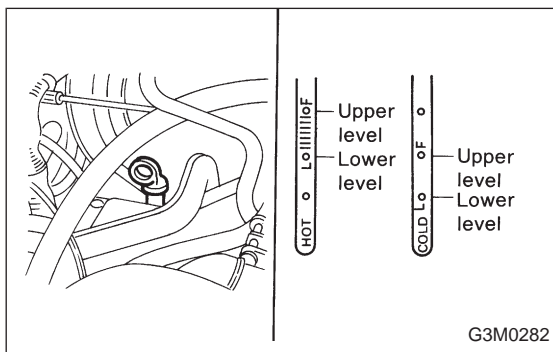

(7) Add and check ATF.

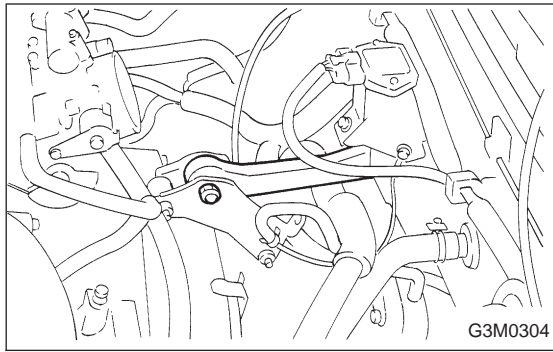

2. DUTY SOLENOID C AND TRANSFER VALVE BODY

1) Removal

(1) Remove pitching stopper.

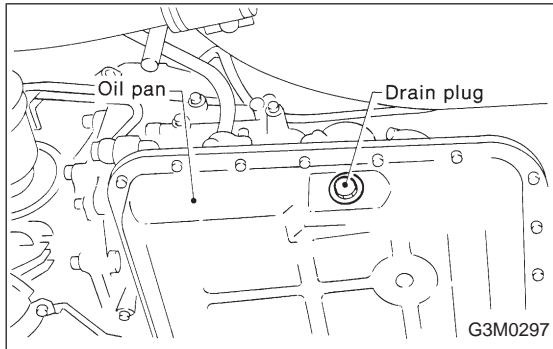

(2) Raise car and drain ATF.

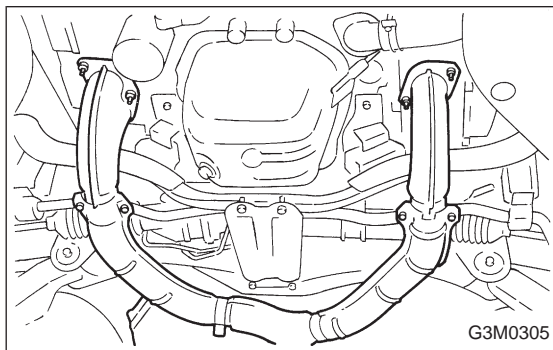

(3) Remove front exhaust pipe.

Disconnect oxygen sensor connector, and remove exhaust pipe.

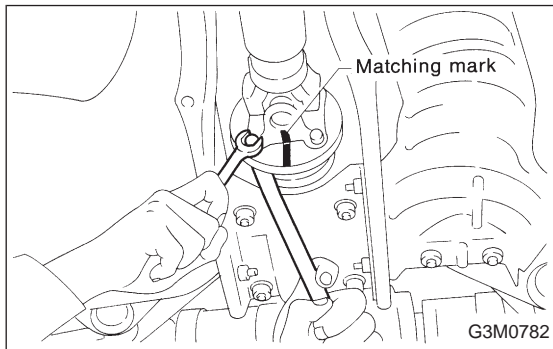

(4) Remove propeller shaft.

NOTE:

Before removing propeller shaft, scribe matching marks on propeller shaft and rear differential coupling.

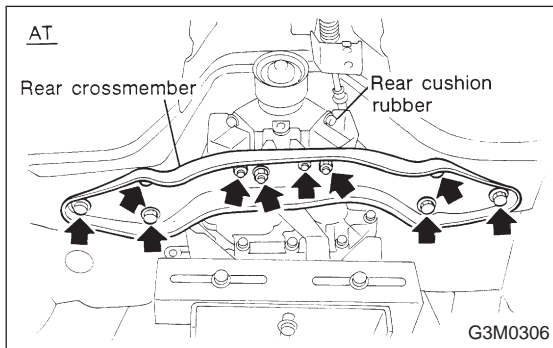

(5) Remove rear crossmember.

- Support transmission using a transmission jack and raise slightly.
- Remove bolts and nuts as shown in Figure.

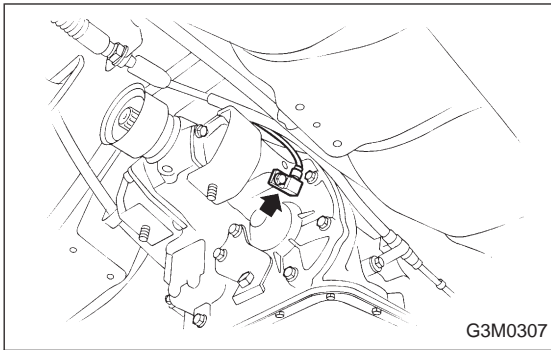

(6) Remove vehicle speed sensor 1.

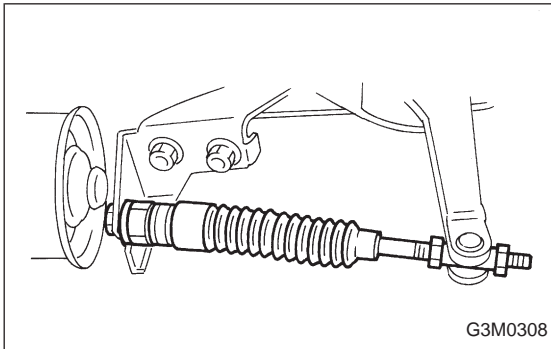

(7) Remove extension and gasket.

- Remove gear select cable nut.
- Move gear select cable so that extension bolts can be removed.

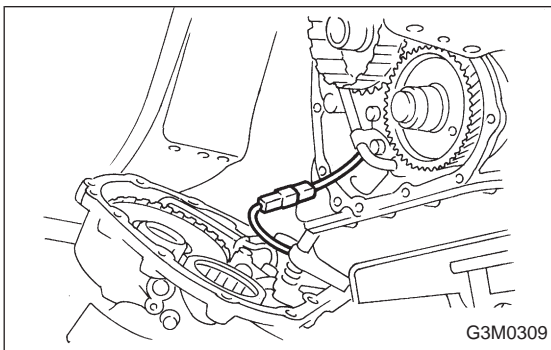

- Remove bolts.
- Remove extension and disconnect duty solenoid C connector.

CAUTION:

Do not force extension back before disconnecting solenoid connector. Otherwise, harness may be damaged.

NOTE:

Use a container to catch oil flowing from extension.

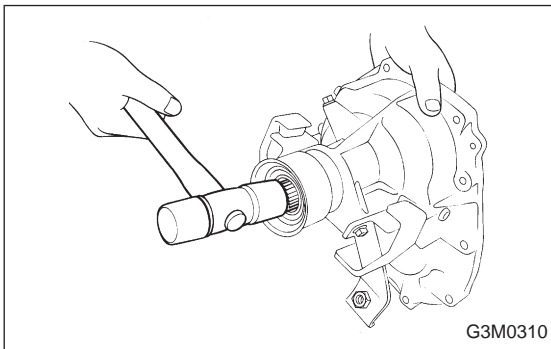

(8) Remove duty solenoid C and transfer valve body from extension.

- Remove transfer clutch drum.

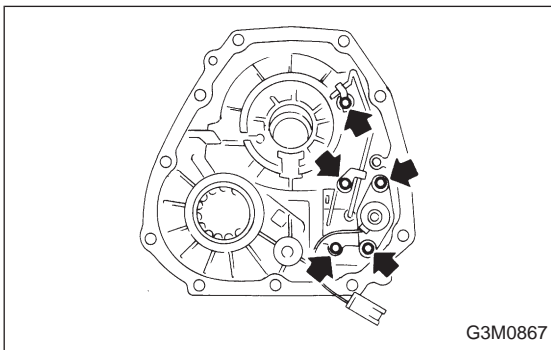

- Remove clamp which secures pipe.
- Remove bolts.

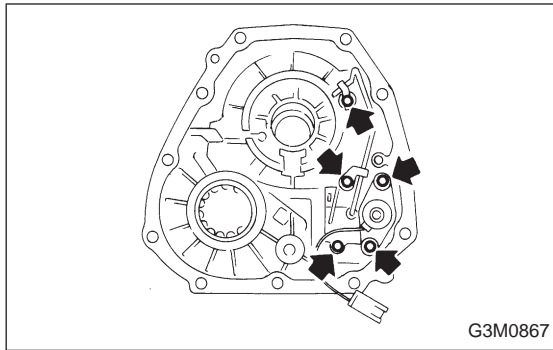

2) Installation

- (1) Install duty solenoid C and transfer valve body.
- Install duty solenoid C and transfer valve body.
 - Install pipe and clamp.

Tightening torque:

$8 \pm 1 \text{ N}\cdot\text{m}$ ($0.8 \pm 0.1 \text{ kg}\cdot\text{m}$, $5.8 \pm 0.7 \text{ ft}\cdot\text{lb}$)

- Install clutch drum.

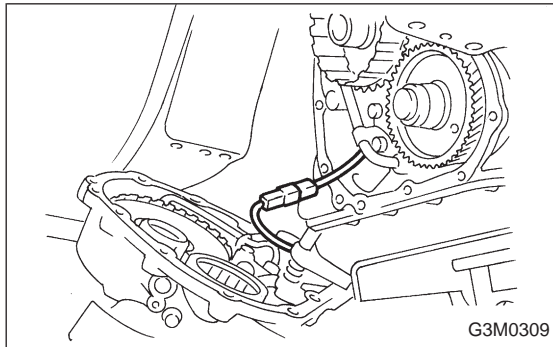

- (2) Install extension.
- Connect connector.
 - Tighten 11 bolts.

Tightening torque:

$25 \pm 1 \text{ N}\cdot\text{m}$ ($2.5 \pm 0.1 \text{ kg}\cdot\text{m}$, $18.1 \pm 0.7 \text{ ft}\cdot\text{lb}$)

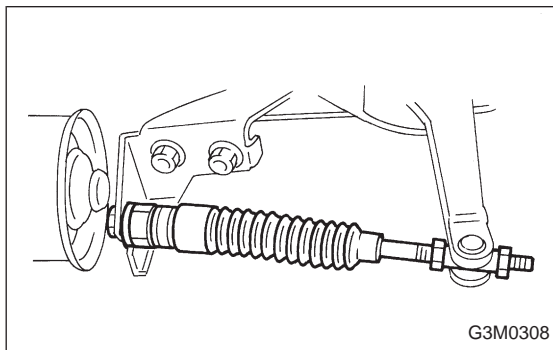

- Install gear select cable.

Tightening torque:

$14 \pm 4 \text{ N}\cdot\text{m}$ ($1.4 \pm 0.4 \text{ kg}\cdot\text{m}$, $10.1 \pm 2.9 \text{ ft}\cdot\text{lb}$)

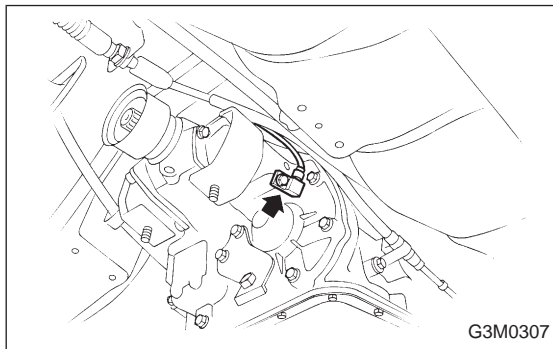

- (3) Install vehicle speed sensor 1.

Tightening torque:

$7 \pm 1 \text{ N}\cdot\text{m}$ ($0.7 \pm 0.1 \text{ kg}\cdot\text{m}$, $5.1 \pm 0.7 \text{ ft}\cdot\text{lb}$)

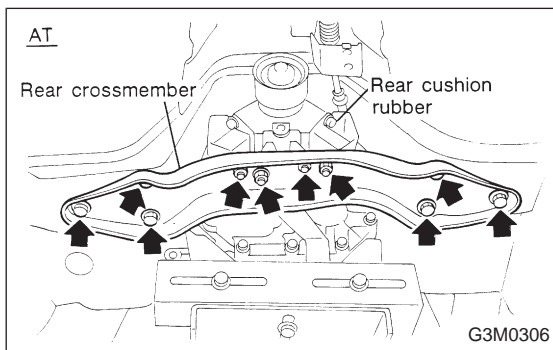

- (4) Install rear crossmember.

- Tighten bolts.

Tightening torque:**Crossmember to body**

$68 \pm 15 \text{ N}\cdot\text{m}$ ($7.0 \pm 1.5 \text{ kg}\cdot\text{m}$, $50.6 \pm 10.8 \text{ ft}\cdot\text{lb}$)

Crossmember to cushion

$18 \pm 5 \text{ N}\cdot\text{m}$ ($1.8 \pm 0.5 \text{ kg}\cdot\text{m}$, $13.0 \pm 3.6 \text{ ft}\cdot\text{lb}$)

- Lower and remove transmission jack.

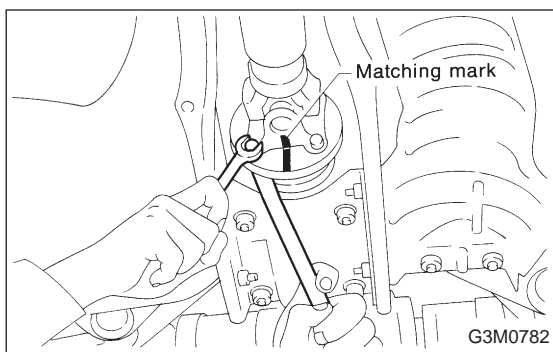

(5) Install propeller shaft.

Tightening torque:

At rear differential

$23 \pm 5 \text{ N}\cdot\text{m}$ ($2.3 \pm 0.5 \text{ kg}\cdot\text{m}$, $16.6 \pm 3.6 \text{ ft}\cdot\text{lb}$)

At center bearing

$39 \pm 5 \text{ N}\cdot\text{m}$ ($4.0 \pm 0.5 \text{ kg}\cdot\text{m}$, $28.9 \pm 3.6 \text{ ft}\cdot\text{lb}$)

NOTE:

Align matching marks on propeller shaft and rear differential coupling.

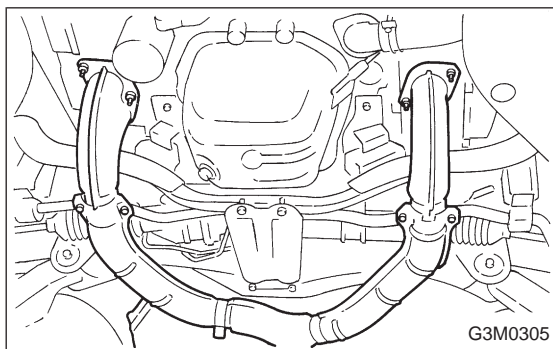

(6) Install front exhaust pipe

Tightening torque:

At engine

$29 \pm 5 \text{ N}\cdot\text{m}$ ($3.0 \pm 0.5 \text{ kg}\cdot\text{m}$, $21.7 \pm 3.6 \text{ ft}\cdot\text{lb}$)

At hanger

$29 \pm 5 \text{ N}\cdot\text{m}$ ($3.0 \pm 0.5 \text{ kg}\cdot\text{m}$, $21.7 \pm 3.6 \text{ ft}\cdot\text{lb}$)

At front and rear connections

$18 \pm 5 \text{ N}\cdot\text{m}$ ($1.8 \pm 0.5 \text{ kg}\cdot\text{m}$, $13.0 \pm 3.6 \text{ ft}\cdot\text{lb}$)

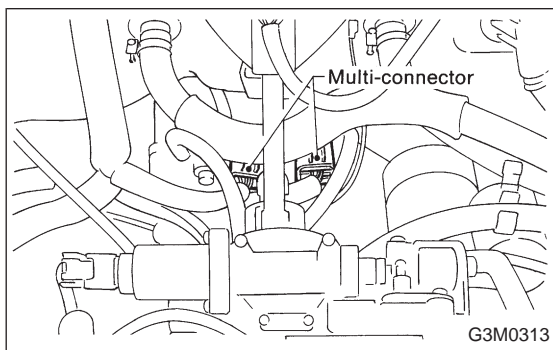

(7) Lower and remove jack.

(8) Connect the following parts:

- Oxygen sensor connector
- Multi-connector

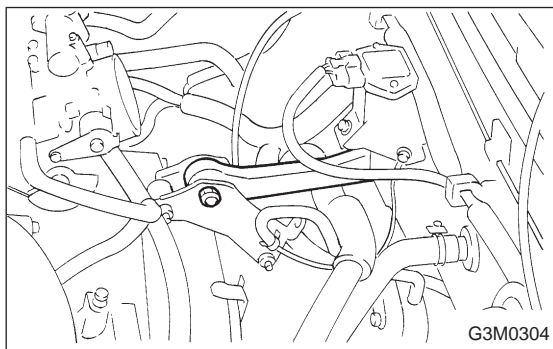

(9) Install pitching stopper.

Tightening torque:

Body side

$57 \pm 10 \text{ N}\cdot\text{m}$ ($5.8 \pm 1.0 \text{ kg}\cdot\text{m}$, $42.0 \pm 7.2 \text{ ft}\cdot\text{lb}$)

Engine side

$49 \pm 5 \text{ N}\cdot\text{m}$ ($5.0 \pm 0.5 \text{ kg}\cdot\text{m}$, $36.2 \pm 3.6 \text{ ft}\cdot\text{lb}$)

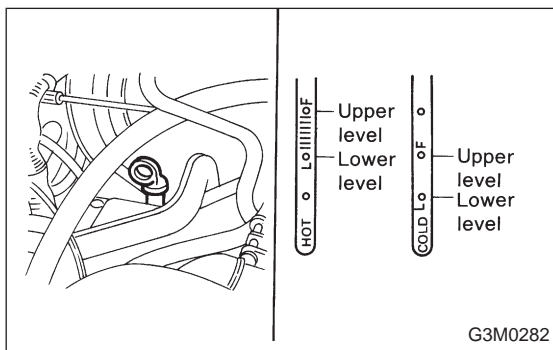

(10) Replenish ATF and check oil level. Check for leaks.