

6. Control Valve Body

The control valve is composed of parts which are accurately machined to a high degree and should be handled carefully during disassembly and assembly. As these parts are similar in shape, they should be arranged in neat order on a table after disassembly so that they can be easily installed to their original positions. Spring loaded parts should be also handled carefully, as springs may jump out of place when the parts are disassembled or removed. Extreme care should be taken so as not to drop valves on the floor. Before assembling, the parts and valves should be dipped in a container filled with the ATF. Make sure that the valves are clean and free from any foreign material before assembly. Torque specifications should also be observed.

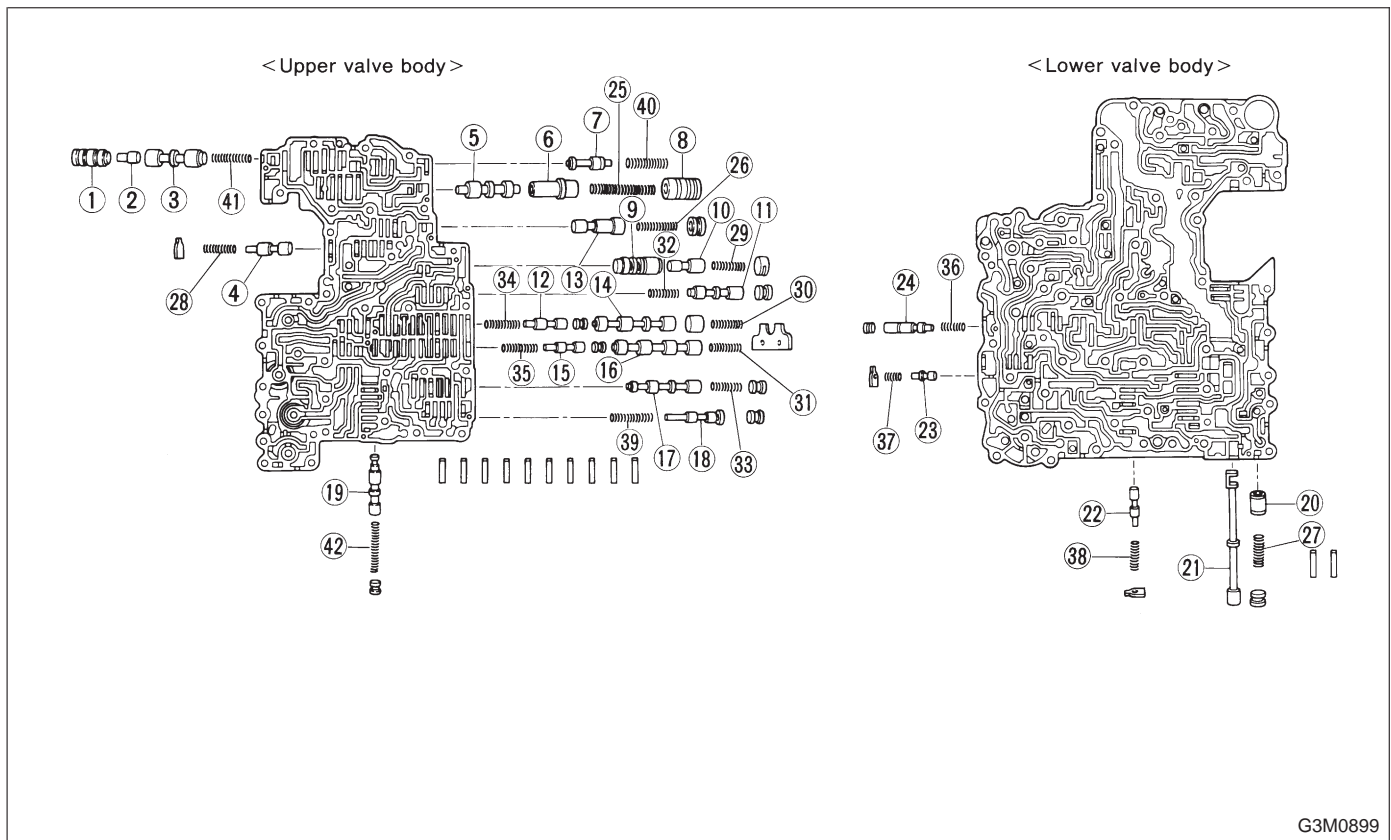

G3M0899

- | | | |
|-------------------------------------|-------------------------------------|--------------------------------------|
| ① Lock-up control sleeve | ⑱ Overrunning clutch reducing valve | ⑳ 4-2 relay spring |
| ② Lock-up control plug | ⑲ Shuttle shift valve | ㉑ Servo charger spring |
| ③ Lock-up control valve | ㉒ Manual valve | ㉒ 3-2 timing spring |
| ④ Pilot valve | ㉓ Forward clutch control valve | ㉓ 1st reducing spring |
| ⑤ Pressure regulator valve | ㉔ 1st reducing valve | ㉔ Overrunning clutch reducing spring |
| ⑥ Pressure regulator plug | ㉕ 3-2 timing valve | ㉕ Torque converter regulator spring |
| ⑦ Torque converter regulation valve | ㉖ Servo charger valve | ㉖ Lock-up control spring |
| ⑧ Pressure regulator sleeve plug | ㉗ Pressure regulator spring | ㉗ Shuttle duty shift spring |
| ⑨ Accumulator control sleeve | ㉘ Pressure modifier spring | |
| ⑩ Accumulator control plug | ㉙ Modifier accumulator spring | |
| ⑪ Shuttle duty shift valve | ㉚ Pilot spring | |
| ⑫ 4-2 sequence valve | ㉛ Accumulator control spring | |
| ⑬ Pressure modifier valve | ㉜ Shift B spring | |
| ⑭ Shift valve B | ㉝ Shift A spring | |
| ⑮ 4-2 relay valve | ㉞ Shuttle shift spring | |
| ⑯ Shift valve A | ㉟ Overrunning clutch control spring | |
| ⑰ Overrunning clutch control valve | ㊱ 4-2 sequence spring | |

Unit: mm (in)

No.	Part name	Wire dia.	Outer dia.	Effective turn	Free length
25	Pressure regulator spring	1.6 (0.063)	14.0 (0.551)	5.6	31.5 (1.240)
26	Pressure modifier spring	0.8 (0.031)	6.8 (0.268)	10.0	31.95 (1.2579)
27	Modifier accumulator spring	1.3 (0.051)	9.8 (0.386)	8.8	30.5 (1.201)
28	Pilot spring	1.1 (0.043)	9.1 (0.358)	8.3	25.7 (1.012)
29	Accumulator control spring	0.4 (0.016)	6.6 (0.260)	11.0	27.5 (1.083)
30	Shift B spring	0.65 (0.0256)	7.0 (0.276)	9.5	25.0 (0.984)
31	Shift A spring	0.5 (0.020)	7.0 (0.276)	9.5	25.0 (0.984)
32	Shuttle shift spring	0.75 (0.0295)	5.65 (0.2224)	27.6	51.0 (2.008)
33	Overrunning clutch control spring	0.6 (0.024)	7.0 (0.276)	7.9	23.6 (0.929)
34	4-2 sequence spring	0.55 (0.0217)	6.95 (0.2736)	11.0	29.1 (1.146)
35	4-2 relay spring	0.55 (0.0217)	6.95 (0.2736)	11.0	29.1 (1.146)
36	Servo charger spring	0.7 (0.028)	6.7 (0.264)	9.0	23.0 (0.906)
37	3-2 timing spring	0.75 (0.0295)	6.75 (0.2657)	7.5	20.55 (0.8091)
38	1st reducing spring	0.75 (0.0295)	6.75 (0.2657)	12.5	25.4 (1.000)
39	Overrunning clutch reducing spring	1.05 (0.0413)	7.05 (0.2776)	15.21	34.7 (1.366)
40	Torque converter regulator spring	1.3 (0.051)	9.0 (0.354)	11.7	38.0 (1.496)
41	Lock-up control spring	0.75 (0.0295)	13.0 (0.512)	3.5	18.5 (0.728)
42	Shuttle duty shift spring	0.7 (0.028)	6.0 (0.236)	12.0	26.5 (1.043)

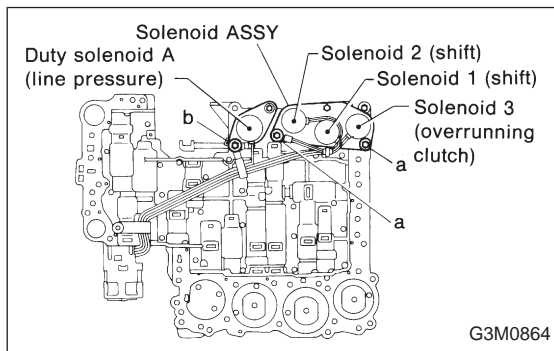

A: DISASSEMBLY

1) Remove the following parts from the upper valve body.

- (1) Solenoid assembly (shift 1-2-3)
- (2) Duty solenoid A (line pressure)

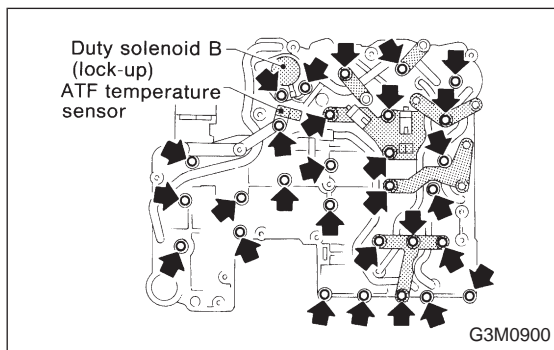

2) Remove the following parts from the lower valve body.

- (1) Duty solenoid B (lock-up)
- (2) ATF temperature sensor
- (3) Bracket

3) Separate the upper valve body and lower valve body.

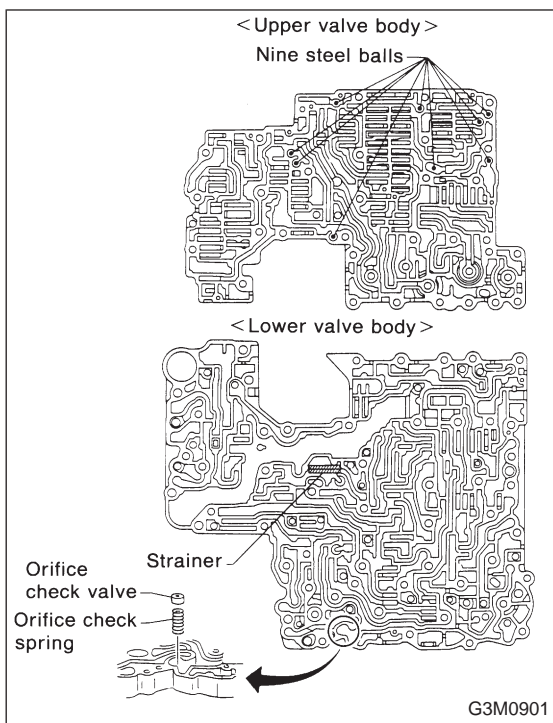

CAUTION:

- Do not lose the nine (9) steel balls contained in the upper valve body.
- Do not lose an orifice and a strainer contained in the lower valve body.

NOTE:

Remove the upper-lower valve body tightening bolts. Then remove two locating bolts. (←)
 During ordinary servicing, clean the control valve bodies in this condition, without further disassembly.
 In the event of a seized clutch or other problem, disassemble the control valve bodies further, and clean the component parts.

B: INSPECTION

Make sure that each component is free of harmful gouges, cuts, or dust.

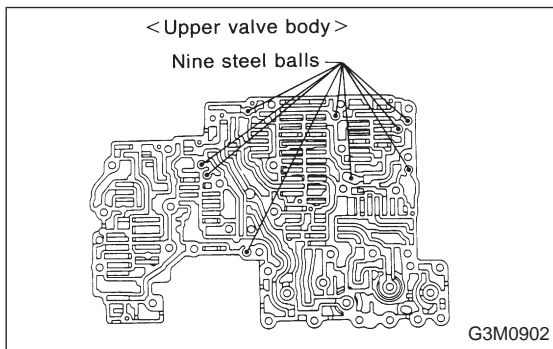

C: ASSEMBLY

1) Install the nine steel balls to the upper valve body.

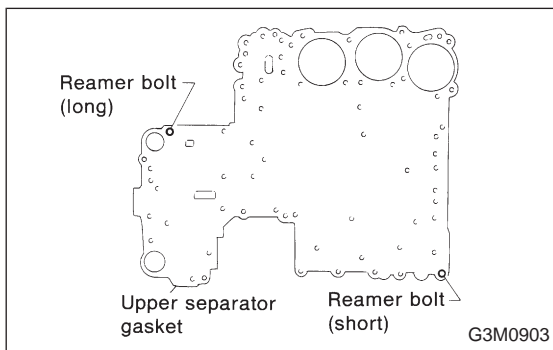

2) From under upper valve body, install two bolts using washers and position upper separator gasket.

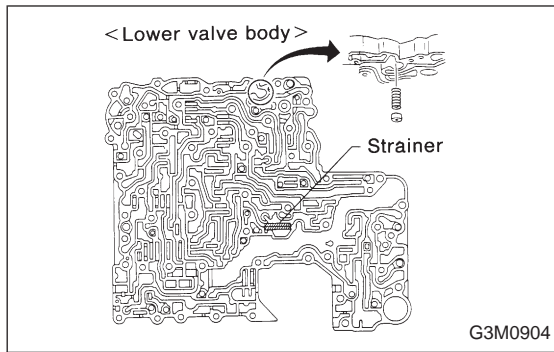

3) Install the orifice check valve, orifice check spring and filter to the lower valve body.

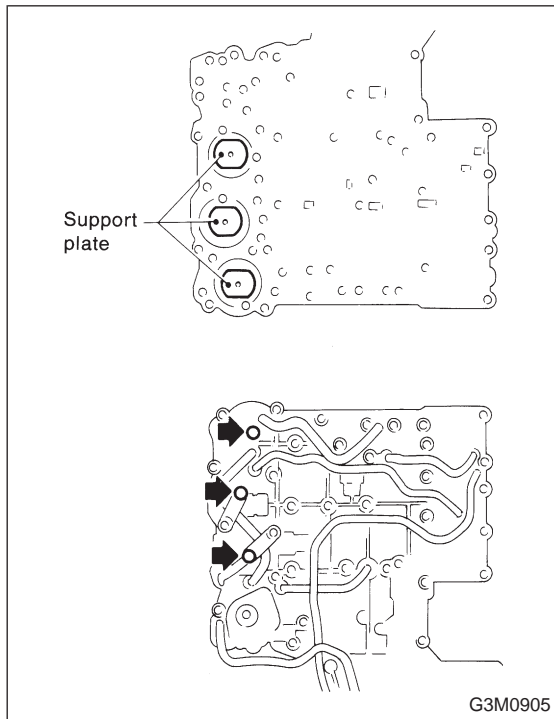

4) Install lower separate gasket and separate plate on lower body in that order, then temporarily tighten three support plates and two brackets.

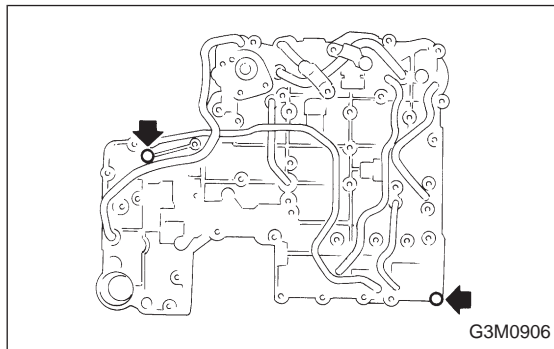

5) Temporarily assemble lower valve body to upper valve body.

CAUTION:

Be careful not to drop the upper body interior steel ball, or the lower body interior filter, orifice check spring, or orifice check valve.

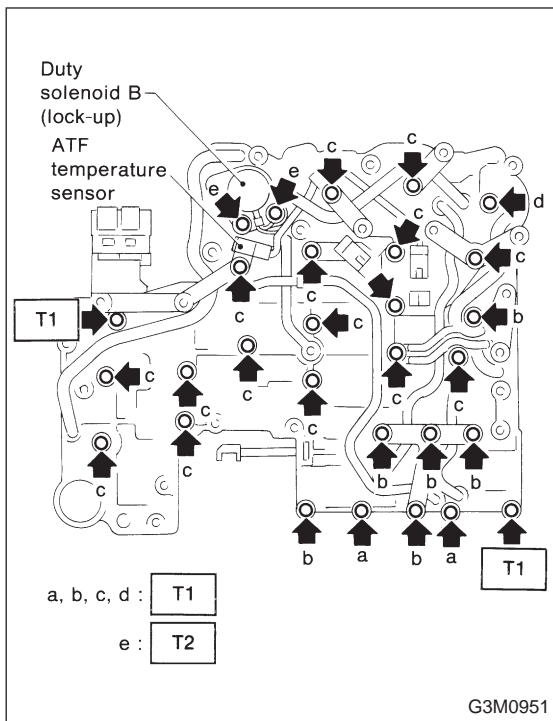

- 6) Install the duty solenoid B, ATF temperature sensor and four bracket.
- 7) Tighten twenty seven bolts & washers and two reamer bolts.

Tightening torque:

T1: $8 \pm 1 \text{ N}\cdot\text{m}$ ($0.8 \pm 0.1 \text{ kg}\cdot\text{m}$, $5.8 \pm 0.7 \text{ ft}\cdot\text{lb}$)

T2: $11.3 \pm 1.5 \text{ N}\cdot\text{m}$ ($1.15 \pm 0.15 \text{ kg}\cdot\text{m}$, $8.3 \pm 1.1 \text{ ft}\cdot\text{lb}$)

Unit: mm (in)

	a	b	c	d	e
Length	70 (2.76)	50 (1.97)	33 (1.30)	27 (1.06)	28 (1.10)
Numbers	2	6	16	1	2

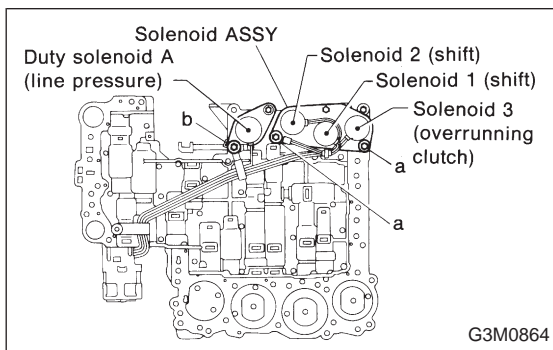

- 8) Install the shift solenoid and duty solenoid A.

a length : 16 mm (0.63 in)

b length : 27 mm (1.06 in)

Tightening torque:

$8.3 \pm 1.5 \text{ N}\cdot\text{m}$ ($0.85 \pm 0.15 \text{ kg}\cdot\text{m}$, $6.1 \pm 1.1 \text{ ft}\cdot\text{lb}$)

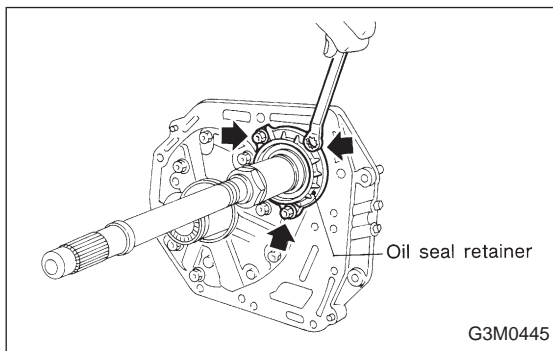

7. Oil Pump Assembly

A: DISASSEMBLY

- 1) Remove the oil seal retainer.
Also remove the O-ring and oil seal (air breather).

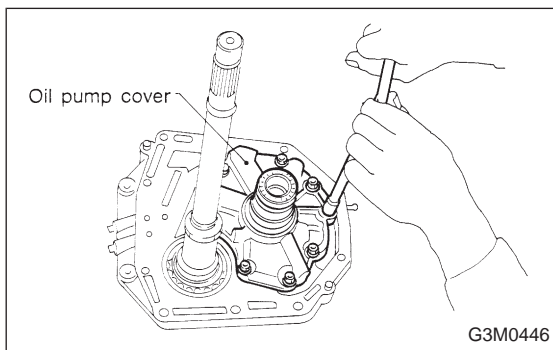

- 2) Remove the oil pump cover.

NOTE:

Lightly tap the end of the stator shaft to remove the cover.