

- 6) Install the duty solenoid B, ATF temperature sensor and four bracket.
- 7) Tighten twenty seven bolts & washers and two reamer bolts.

Tightening torque:

T1: $8 \pm 1 \text{ N}\cdot\text{m}$ ($0.8 \pm 0.1 \text{ kg}\cdot\text{m}$, $5.8 \pm 0.7 \text{ ft}\cdot\text{lb}$)

T2: $11.3 \pm 1.5 \text{ N}\cdot\text{m}$ ($1.15 \pm 0.15 \text{ kg}\cdot\text{m}$, $8.3 \pm 1.1 \text{ ft}\cdot\text{lb}$)

Unit: mm (in)

	a	b	c	d	e
Length	70 (2.76)	50 (1.97)	33 (1.30)	27 (1.06)	28 (1.10)
Numbers	2	6	16	1	2

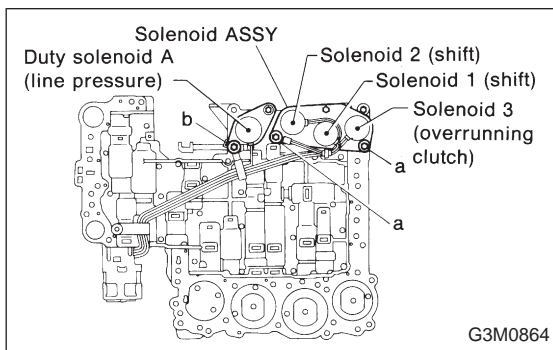

- 8) Install the shift solenoid and duty solenoid A.

a length : 16 mm (0.63 in)

b length : 27 mm (1.06 in)

Tightening torque:

$8.3 \pm 1.5 \text{ N}\cdot\text{m}$ ($0.85 \pm 0.15 \text{ kg}\cdot\text{m}$, $6.1 \pm 1.1 \text{ ft}\cdot\text{lb}$)

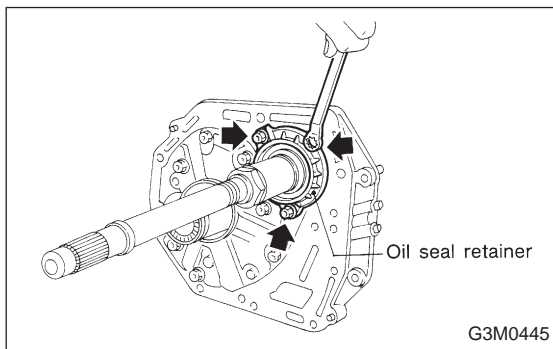

7. Oil Pump Assembly

A: DISASSEMBLY

- 1) Remove the oil seal retainer.
Also remove the O-ring and oil seal (air breather).

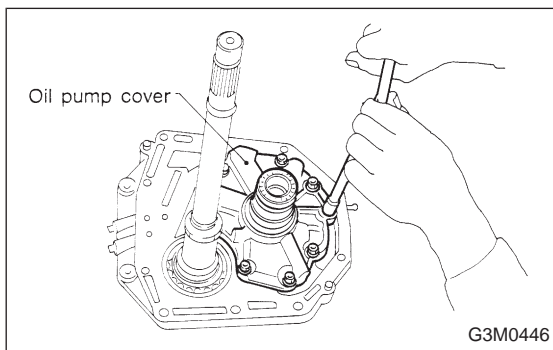

- 2) Remove the oil pump cover.

NOTE:

Lightly tap the end of the stator shaft to remove the cover.

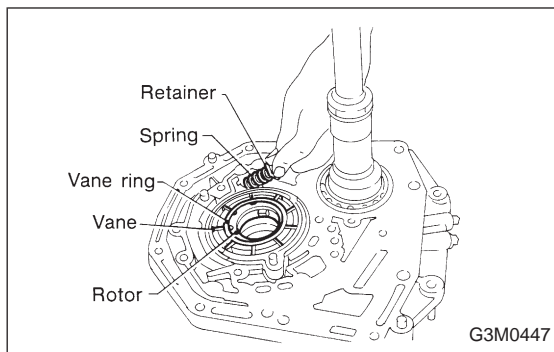

3) Remove the retainer and return spring. Then remove the rotor, two vane rings and nine vanes.

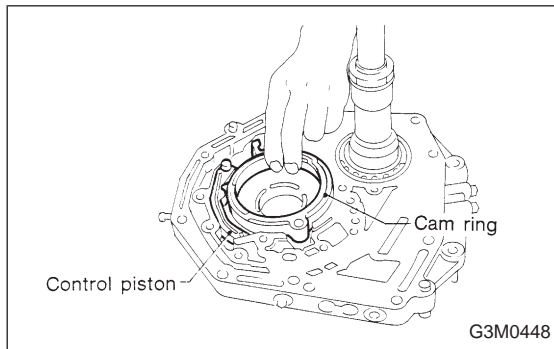

4) Remove the cam ring and control piston. Also remove the O-ring, friction ring, two side seals, and plain seal.

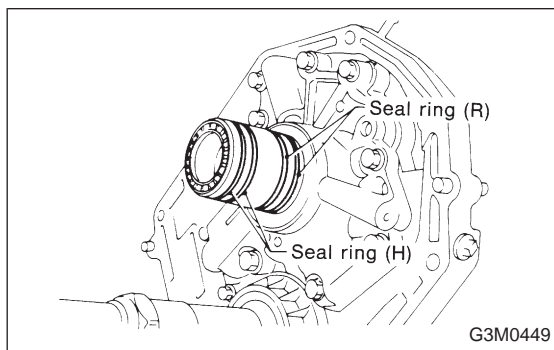

5) Remove two seal rings (R) and two seal rings (H).

B: INSPECTION

1) Make sure that each component is free of harmful gouges, cuts, and dust.

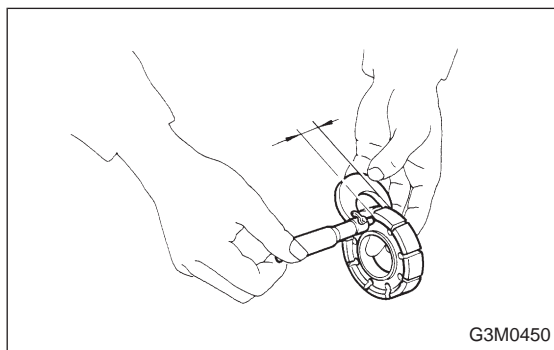

2) Selection of oil pump components (rotor, vanes, control piston and cam ring):

(1) Using a micrometer, measure the height of the rotor, vanes, control piston and cam ring in at least four positions. (Measure the height at one place for each of the nine vanes.)

NOTE:

- Remove the control piston seals when measuring.
- Remove the friction ring from the cam ring when measuring.

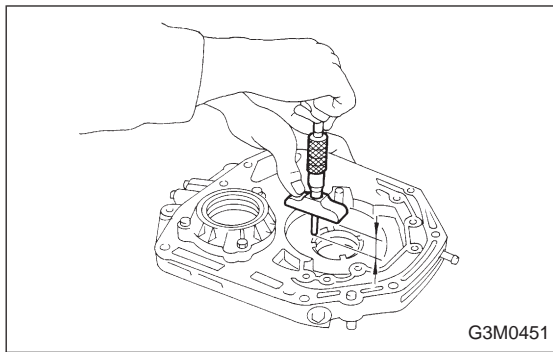

(2) Using a depth gauge, measure the depth of the oil pump housing from the contact/sliding surface of the above mentioned component parts in the same manner as above.

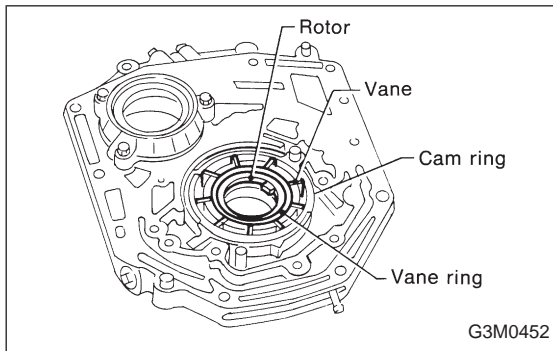

(3) Make sure that the clearances are within the specified wear limits. If the wear limit is exceeded, select pump components so that the standard clearance can be obtained.

Unit: mm (in)

Part name	Wear limit	Standard value
Rotor, control piston, vanes	0.054 (0.0021)	0.030 — 0.044 (0.0012 — 0.0017)
Cam ring	0.034 (0.0013)	0.010 — 0.024 (0.0004 — 0.0009)

NOTE:

Select vanes which are the same height as the rotor.

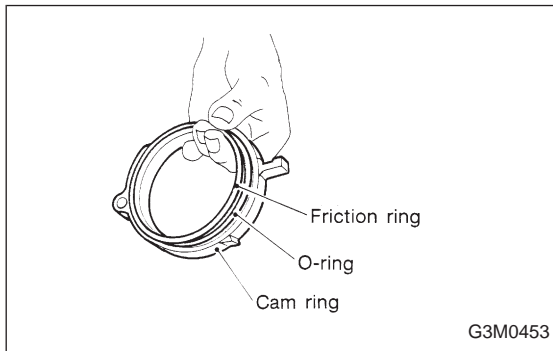

C: ASSEMBLY

1) Coat both the O-ring and friction ring with vaseline and attach to the cam ring. Then fit them into the oil pump housing.

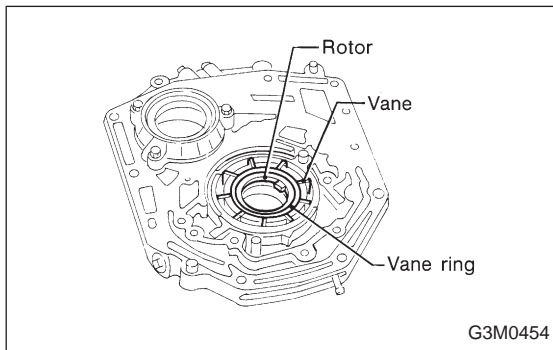

2) Install the vane ring, rotor and vanes into the housing in this sequence.

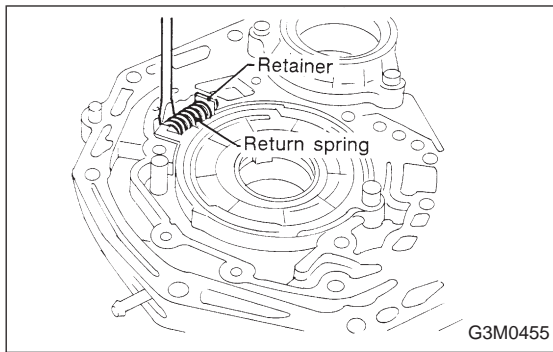

3) Install the return spring and retainer between the housing and cam ring.

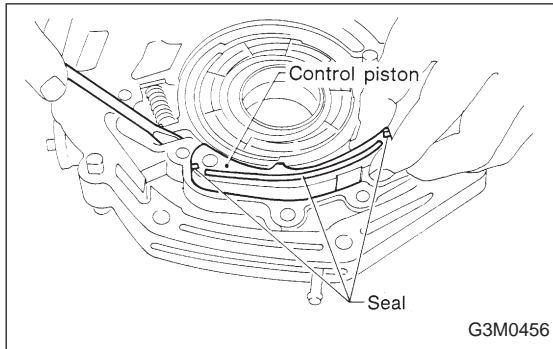

4) Install the control piston to the oil pump housing.

NOTE:

Fit the seal in the piston groove, with the red seals facing the top side. (Two side seals and one plain seal are attached.)

5) Set the rotor at the center of the housing bore. Apply ATF abundantly to each rotary portion.

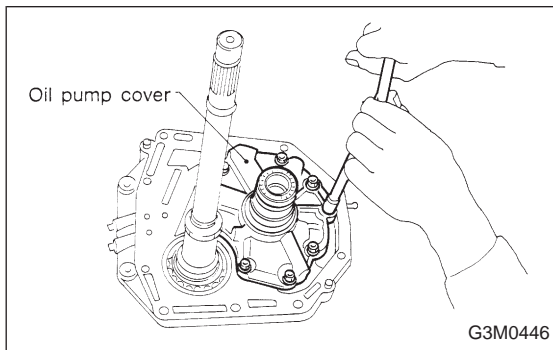

6) Install the oil pump cover.

Tightening torque:

$25 \pm 2 \text{ N}\cdot\text{m}$ ($2.5 \pm 0.2 \text{ kg}\cdot\text{m}$, $18.1 \pm 1.4 \text{ ft}\cdot\text{lb}$)

NOTE:

- Align both pivots with the pivot holes of the cover, and install the cover being careful not to apply undue force to the pivots.
- After assembling, turn the oil pump shaft to check for smooth rotation of the rotor.

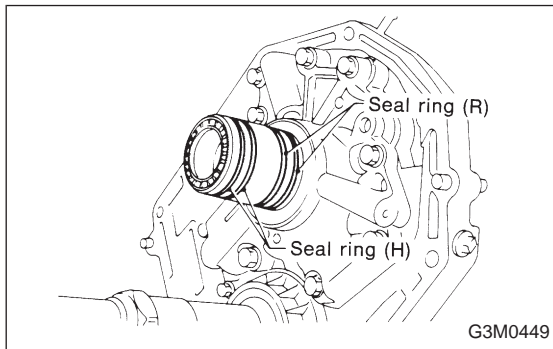

NOTE:

- Install the oil seal retainer and seal rings (R) and (H) after adjusting the drive pinion backlash and tooth contact.