

	Part No.	Thickness mm (in)
	● Available retaining plates	31567AA190
	31567AA200	3.8 (0.150)
	31567AA210	4.0 (0.157)
	31567AA220	4.2 (0.165)
	31567AA230	4.4 (0.173)
	31567AA240	4.6 (0.181)
	31567AA250	4.8 (0.189)
	31567AA260	5.0 (0.197)

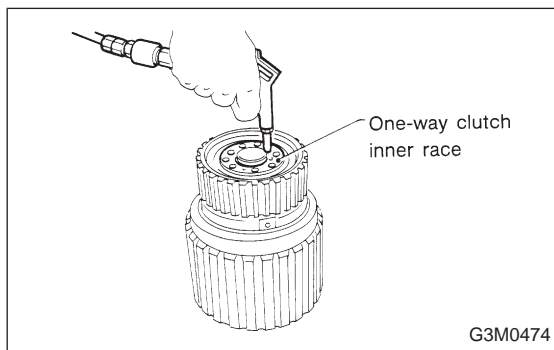
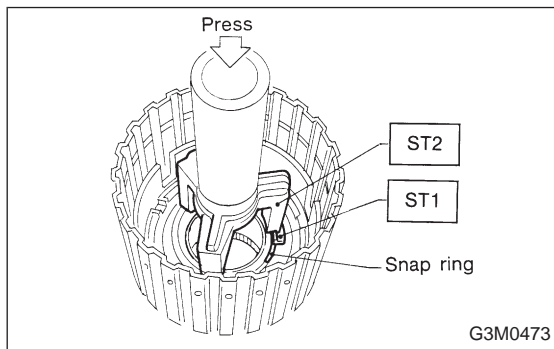
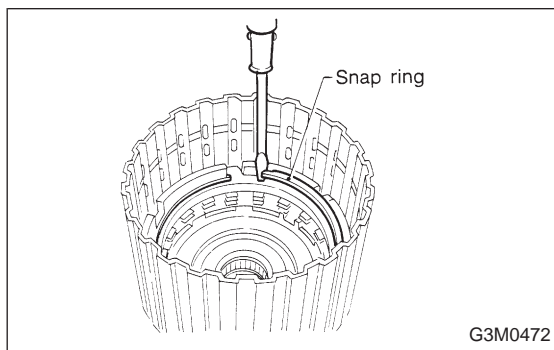
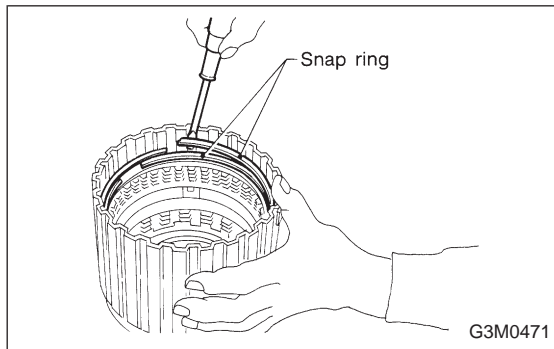

## 11. Forward Clutch Drum

### A: DISASSEMBLY

1) Remove two snap rings from the forward clutch drum.  
2) Remove the retaining plate, drive plates, driven plates and dish plate. (Forward clutch)

3) Remove the snap ring from the forward clutch drum.  
4) Remove the retaining plate, drive plates, driven plates and dish plate. (Overrunning clutch)

5) Compress the spring retainer, and remove the snap ring from the forward clutch, by using ST1 and ST2.

ST1 498627100 SEAT

ST2 398673600 COMPRESSOR

6) Install the one-way clutch inner race to the forward clutch drum, and apply compressed air to remove the overrunning piston and forward piston.

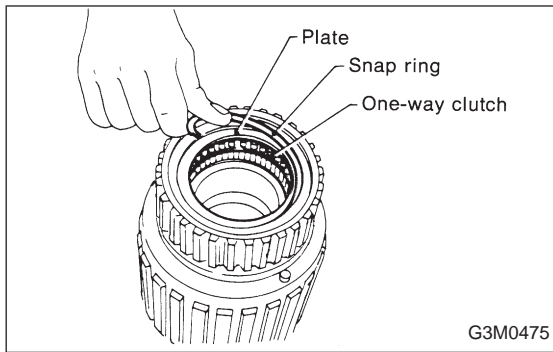

7) Remove the one-way clutch after taking out the snap ring.

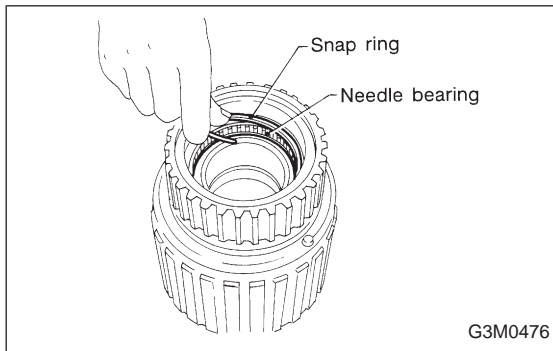

8) Remove the needle bearing after taking out the snap ring.

**B: INSPECTION**

- 1) Drive plate facing for wear and damage
- 2) Snap ring for wear, return spring for setting and breakage, and snap ring retainer for deformation
- 3) Lip seal and lathe cut ring for damage
- 4) Piston and drum check ball for operation

C: ASSEMBLY

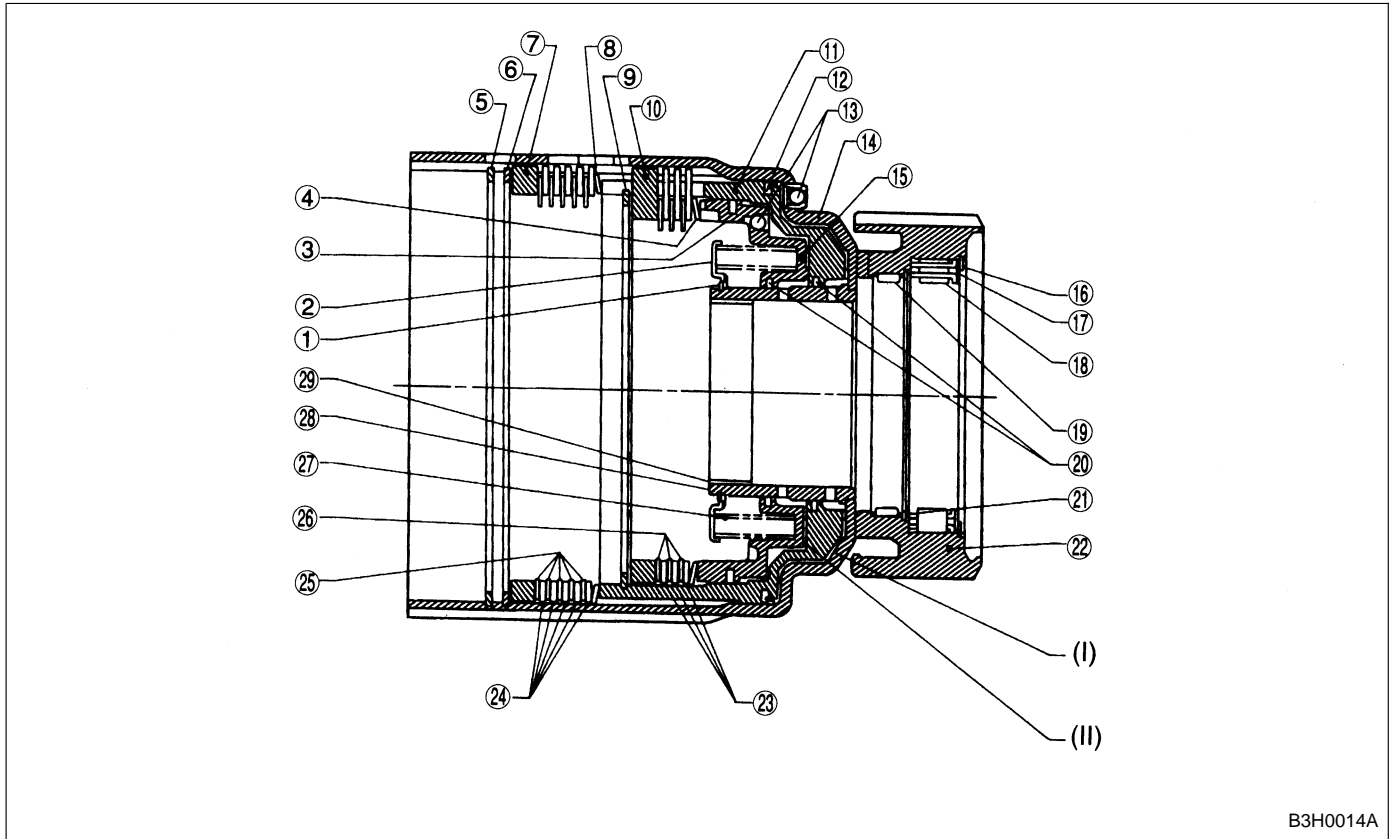

B3H0014A

- |                       |                             |                          |
|-----------------------|-----------------------------|--------------------------|
| ① Snap ring           | ⑪ Forward clutch piston     | ⑳ Snap ring              |
| ② Retainer            | ⑫ Lathe cut seal ring       | ㉑ Outer race             |
| ③ Lathe cut seal ring | ⑬ Drift ball                | ㉒ Driven plate           |
| ④ Dish plate          | ⑭ Forward clutch drum       | ㉓ Driven plate (Thicker) |
| ⑤ Snap ring           | ⑮ Overrunning clutch piston | ㉔ Drive plate (Thinner)  |
| ⑥ Snap ring           | ⑯ Snap ring                 | ㉕ Drive plate            |
| ⑦ Retaining plate     | ⑰ Plate                     | ㉖ Return spring          |
| ⑧ Dish plate          | ⑱ O.W.C. (1-2)              | ㉗ Sleeve                 |
| ⑨ Snap ring           | ㉒ Needle bearing            | ㉘ Bushing                |
| ⑩ Retaining plate     | ㉓ Lathe cut seal ring       |                          |

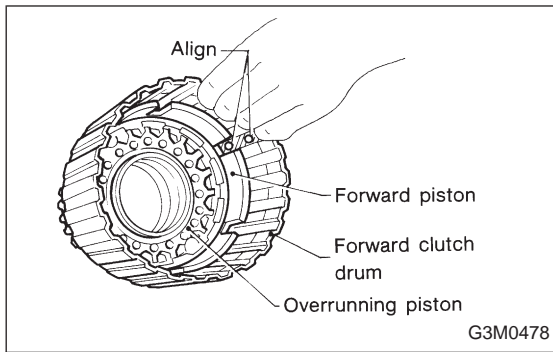

1) Fit the forward piston and overrunning piston to the forward clutch drum.

NOTE:

Align the forward piston cut-out portion with the spline of the drum.

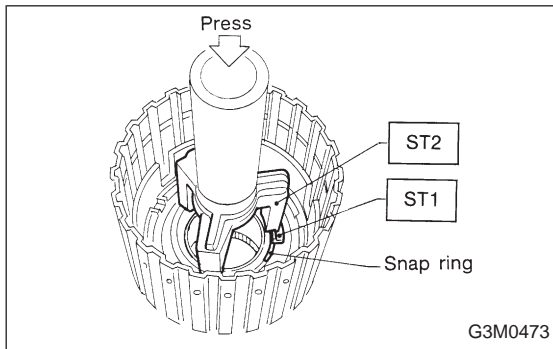

2) Set the retainer on the piston with a press using ST1 and ST2, and attach the snap ring.

ST1 498627000 SEAT  
ST2 398673600 COMPRESSOR

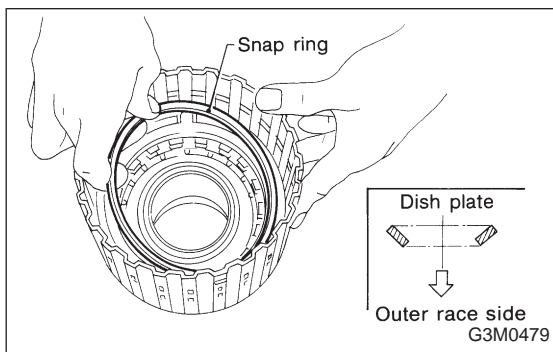

3) Install the dish plate, driven plates, drive plates, and retaining plate, and secure with the snap ring. (Overrunning clutch)

NOTE:

Pay attention to the orientation of the dish plate.

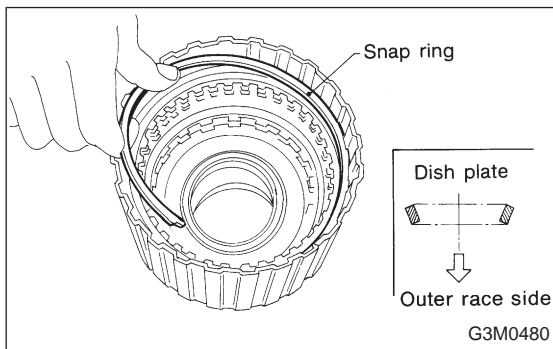

4) Install the dish plates, driven plates (1800 cc / 4 sheets, 2200 cc / 6 sheets), drive plates (1800 cc / 4 sheets, 2200 cc / 6 sheets), and retaining plate, and secure with the snap ring. (Forward clutch)

NOTE:

Pay attention to the orientation of the dish plate.

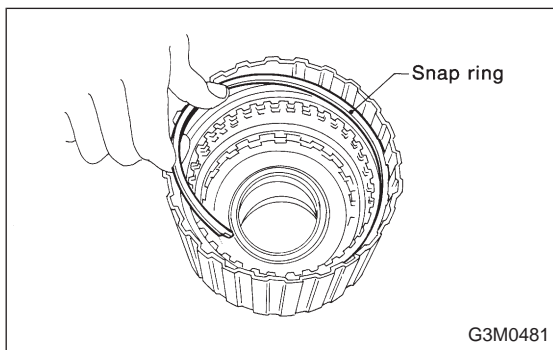

5) Install the snap ring (for front planetary carrier).

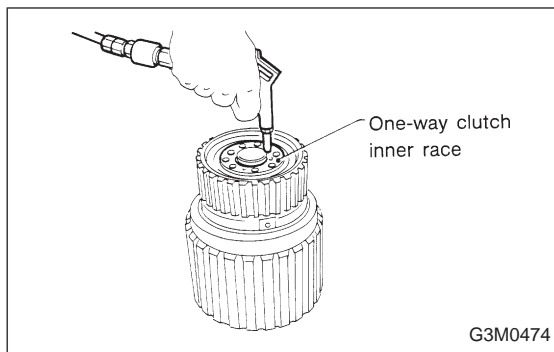

6) Check the forward clutch and overrunning clutch for operation.  
Set the one-way clutch inner race, and apply compressed air for checking.

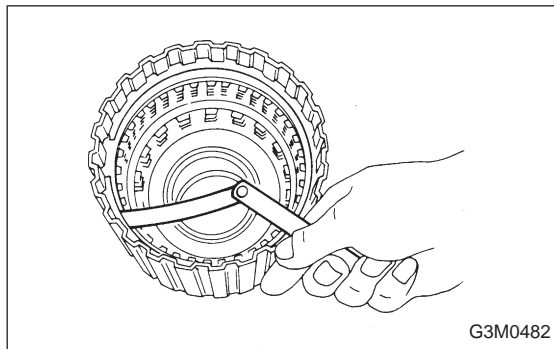

7) Checking clearance

- Forward clutch

**Standard value:**

**0.45 — 0.85 mm (0.0177 — 0.0335 in)**

**Allowable limit:**

**1.6 mm (0.063 in)**

- Overrunning clutch

**Standard value:**

**1.0 — 1.4 mm (0.039 — 0.055 in)**

**Allowable limit:**

**2.0 mm (0.079 in)**

NOTE:

Before measuring clearance, place the same thickness of shim on both sides to prevent retaining plate from tilting.

If the clearance is out of the specified range, select a proper retaining plate so that the standard clearance can be obtained.

	Part No.	Thickness mm (in)
● Forward clutch	31567AA270	4.0 (0.157)
	31567AA280	4.2 (0.165)
	31567AA290	4.4 (0.173)
	31567AA300	4.6 (0.181)
	31567AA310	4.8 (0.189)
	31567AA320	5.0 (0.197)
	31567AA330	5.2 (0.205)

	Part No.	Thickness mm (in)
● Overrunning clutch	31567AA120	8.0 (0.315)
	31567AA130	8.2 (0.323)
	31567AA140	8.4 (0.331)
	31567AA150	8.6 (0.339)
	31567AA160	8.8 (0.346)
	31567AA170	9.0 (0.354)
	31567AA180	9.2 (0.362)

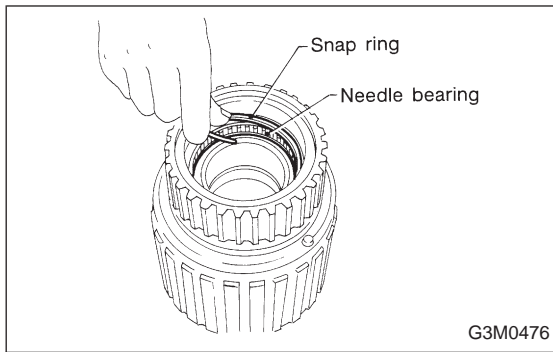

8) Install the needle bearing, and secure with the snap ring.

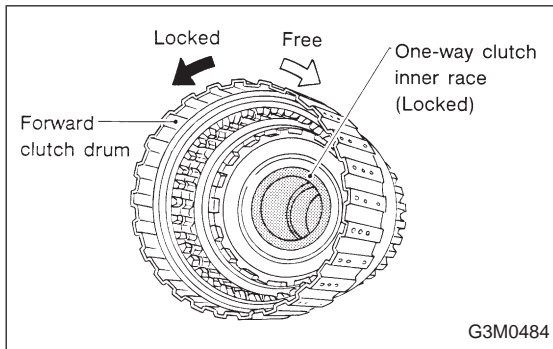

8) Install the one-way clutch (1-2) and plate, and secure with the snap ring.

**NOTE:**

Set the inner race. Make sure that the forward clutch is free in the clockwise direction and locked in the counter-clockwise direction, as viewed from the front of the vehicle.

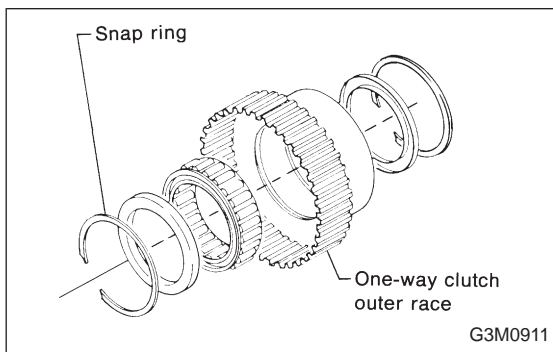

**12. One-way Clutch Outer Race**

**A: DISASSEMBLY**

Remove the snap ring. Then remove the one-way clutch (3-4).

**B: INSPECTION**

Check the sliding surface and one-way clutch (3-4) for any harmful cuts, damage, or other faults.

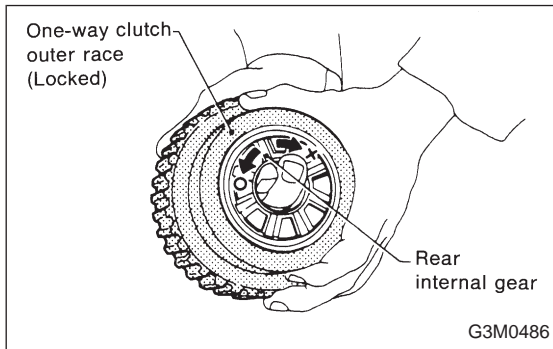

**C: ASSEMBLY**

1) Assemble the one-way clutch (3-4), and secure with the snap ring.

**NOTE:**

Pay attention to the orientation of the one-way clutch (3-4).

2) Assemble the rear internal gear, and secure the outer race. Make sure that the internal gear is locked in the clockwise direction, and free to rotate in the counterclockwise direction.