

14. Differential Case Assembly

A: DISASSEMBLY

- 1) Using a press and ST, remove the tapered roller bearing.
ST 498077000 REMOVER

CAUTION:

Be careful not to damage the speedometer drive gear.

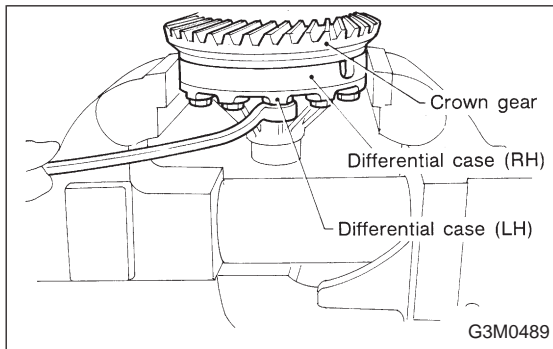

- 2) Secure the case in a vise and remove the crown gear tightening bolts, then separate the crown gear, case (RH) and case (LH).

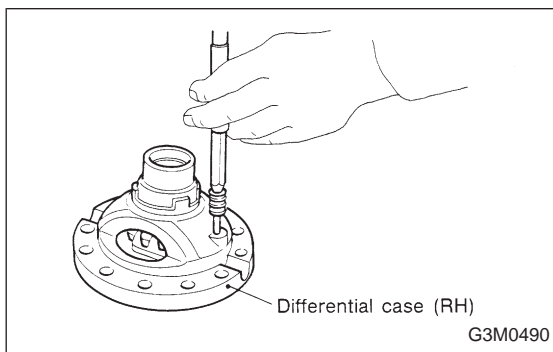

- 3) Pull out the straight pin and shaft, and remove the differential bevel gear, washer, and differential bevel pinion.

B: INSPECTION

Check each component for harmful cuts, damage and other faults.

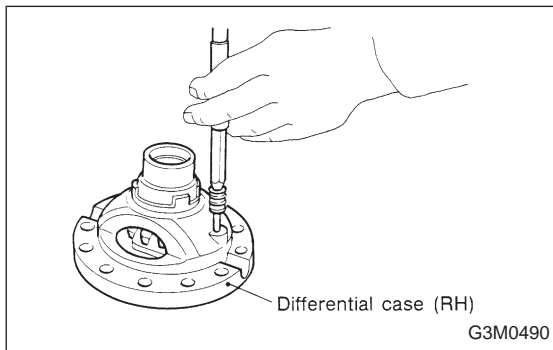

C: ASSEMBLY

- 1) Install the washer, differential bevel gear and differential bevel pinion in the differential case (RH). Insert the pinion shaft, and fit the straight pin.

NOTE:

Install straight pin from reverse direction.

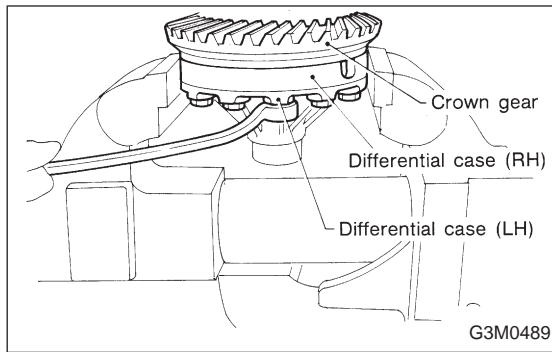

- 2) Install the washer and differential bevel gear to the differential case (LH). Then put the case over the differential case (RH), and connect both cases.
- 3) Install the crown gear and secure by tightening the bolt.

Standard tightening torque:

$62 \pm 3 \text{ N}\cdot\text{m}$ ($6.3 \pm 0.3 \text{ kg}\cdot\text{m}$, $45.6 \pm 2.2 \text{ ft}\cdot\text{lb}$)

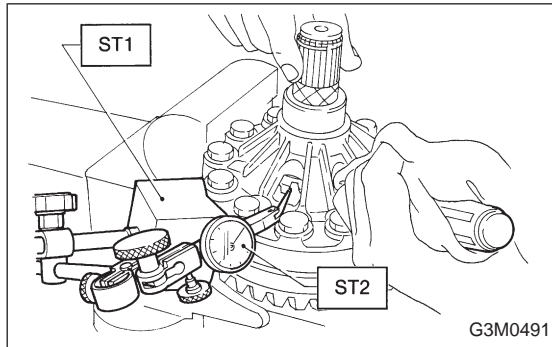

- 4) Measurement of backlash (Selection of washer). Measure the gear backlash with ST1 and ST2, and insert ST2 through the access window of the case.

ST1 498247001 MAGNET BASE

ST2 498247100 DIAL GAUGE

Standard value:

$0.13 - 0.18 \text{ mm}$ ($0.0051 - 0.0071 \text{ in}$)

NOTE:

Measure the backlash by applying a pinion tooth between two bevel gear teeth.

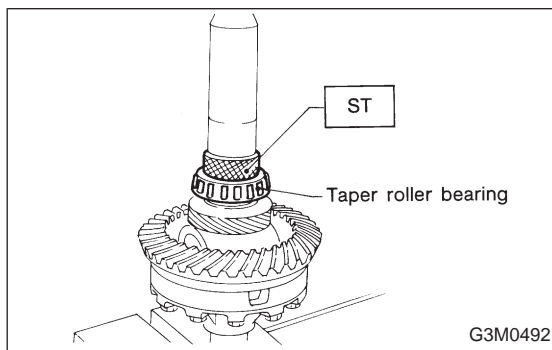

- 5) Install the speedometer drive gear. Then force-fit the taper roller bearing with a press and ST.

ST 398487700 DRIFT

CAUTION:

Be sure to position correctly the locking end of the speedometer drive gear.