

3. Transmission Case

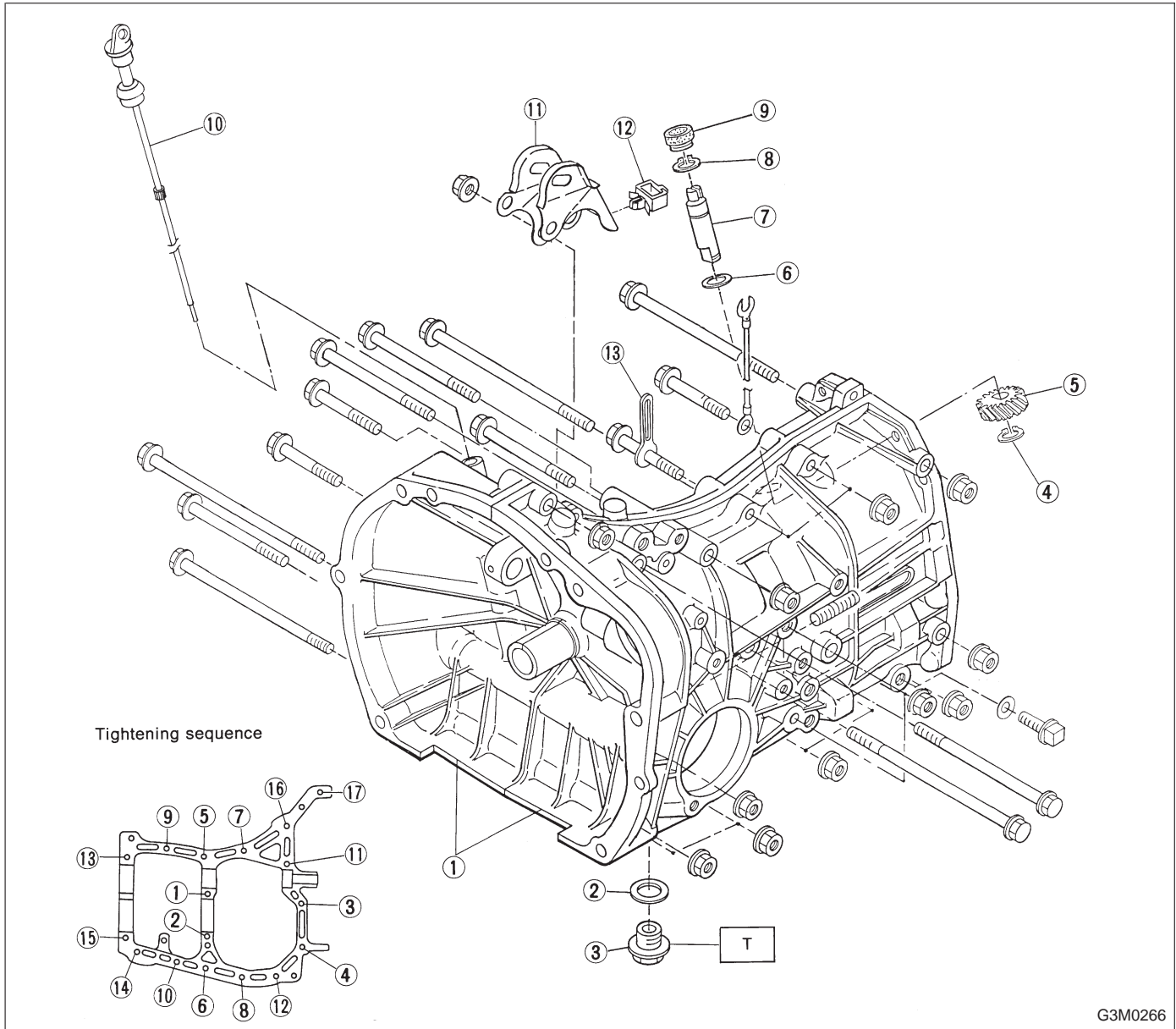

G3M0266

- ① Transmission case ASSY
- ② Gasket
- ③ Drain plug
- ④ Snap ring (Outer)
- ⑤ Speedometer driven gear
- ⑥ Washer
- ⑦ Speedometer shaft
- ⑧ Snap ring (Outer)
- ⑨ Oil seal
- ⑩ Oil level gauge
- ⑪ Pitching stopper bracket
- ⑫ Clamp
- ⑬ Clip

Tightening torque: N·m (kg·m, ft·lb)
T: 41 — 47 (4.2 — 4.8, 30 — 35)

Size	All models	Torque
8 mm bolt	⑤ — ⑮	23 — 26 N·m (2.3 — 2.7 kg·m, 17 — 20 ft·lb)
10 mm bolt	① — ④ ⑯ — ⑰	36 — 42 N·m (3.7 — 4.3 kg·m, 27 — 31 ft·lb)