

11. Front Differential

A: DISASSEMBLY

1) Remove right and left snap rings ① from differential, and then remove two axle drive shafts ②.

NOTE:

During reassembly, reinstall each axle drive shaft in the same place from which it was removed.

2) Loosen twelve bolts ③ and remove hypoid driven gear ④.

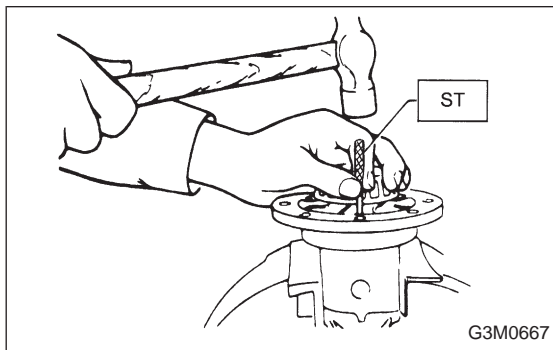
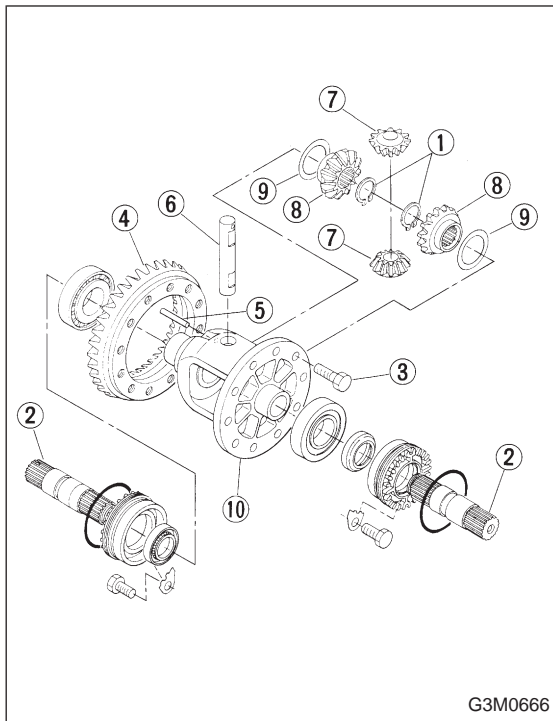

3) Drive out straight pin ⑤ from differential assembly toward hypoid driven gear.

ST 899904100 REMOVER

4) Pull out pinion shaft ⑥, and remove differential bevel pinion ⑦ and gear ⑧ and washer ⑨.

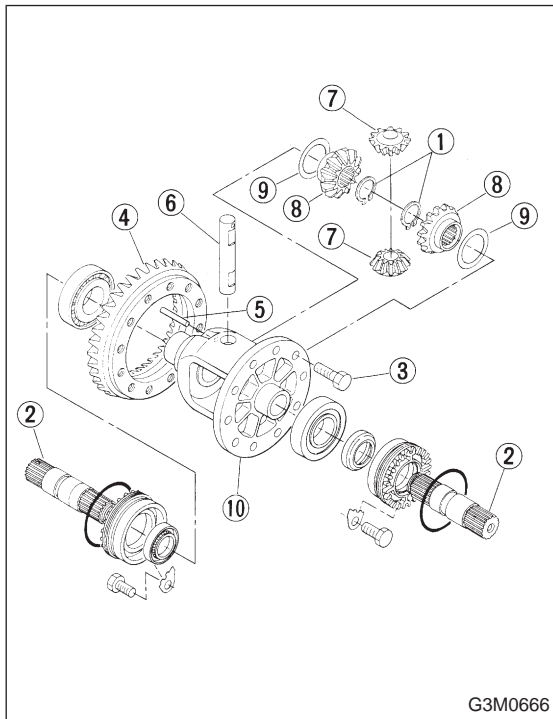

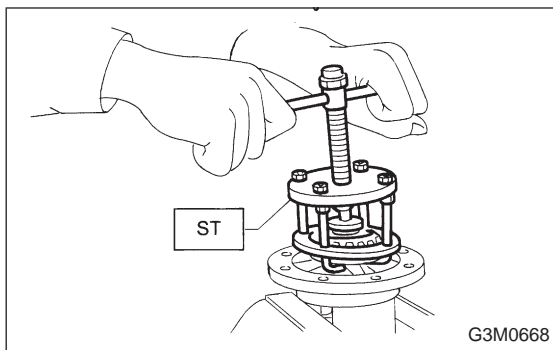

5) Remove roller bearing using ST.
 ST 399527700 PULLER SET

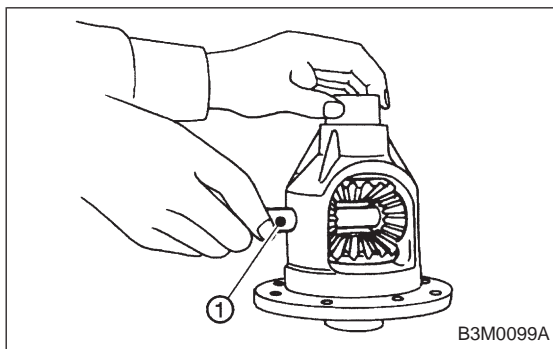

B: ASSEMBLY

1) Install bevel gear and bevel pinion together with washers, and insert pinion shaft ①.

NOTE:
 Face the chamfered side of washer toward gear.

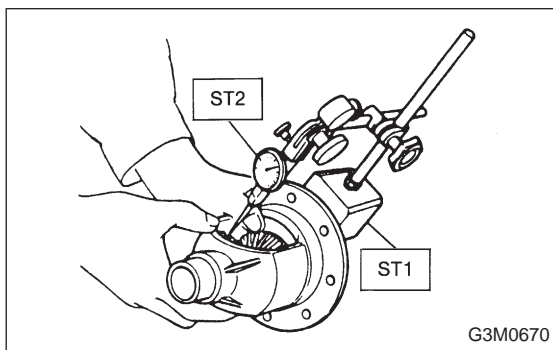

2) Measure backlash between bevel gear and pinion. If it is not within specifications, install a suitable washer to adjust it.

Standard backlash:
 0.13 — 0.18 mm (0.0051 — 0.0071 in)

ST1 498247001 MAGNET BASE
 ST2 498247100 DIAL GAUGE

NOTE:
 Be sure the pinion gear tooth contacts adjacent gear teeth during measurement.

Washer (38.1 x 50 x t)	
Part No.	Thickness mm (in)
803038021	0.925 — 0.950 (0.0364 — 0.0374)
803038022	0.975 — 1.000 (0.0384 — 0.0394)
803038023	1.025 — 1.050 (0.0404 — 0.0413)

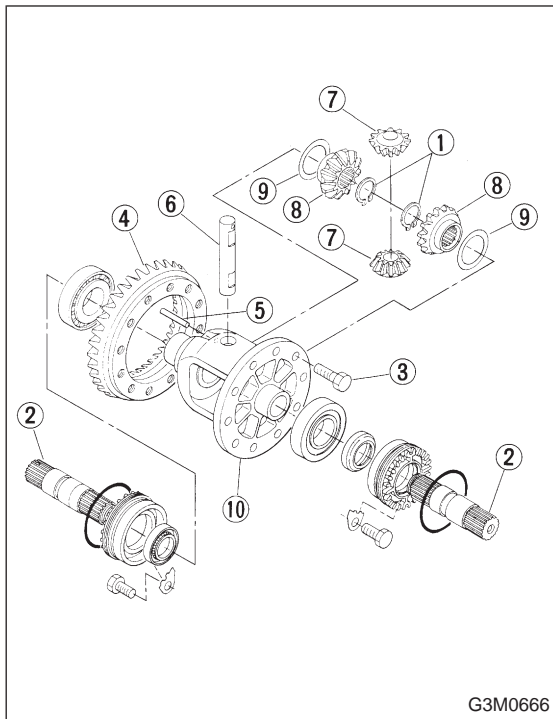

3) Align pinion shaft and differential case at their holes, and drive straight pin ⑤ into holes from the hypoid driven gear side, using ST.

ST 899904100 REMOVER

NOTE:

Lock straight pin after installing.

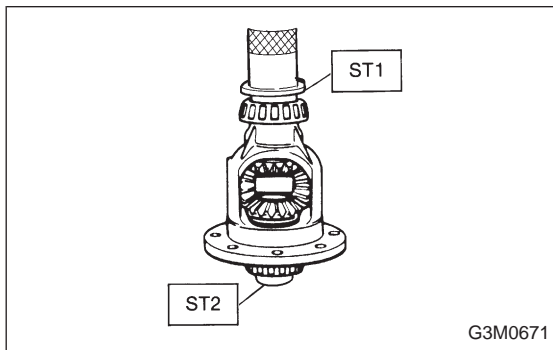

4) Install roller bearing (40 x 80 x 19.75) to differential case.

NOTE:

Be careful because roller bearing outer races are used as a set.

ST1 499277100 BUSH 1-2 INSTALLER

ST2 398497701 ADAPTER

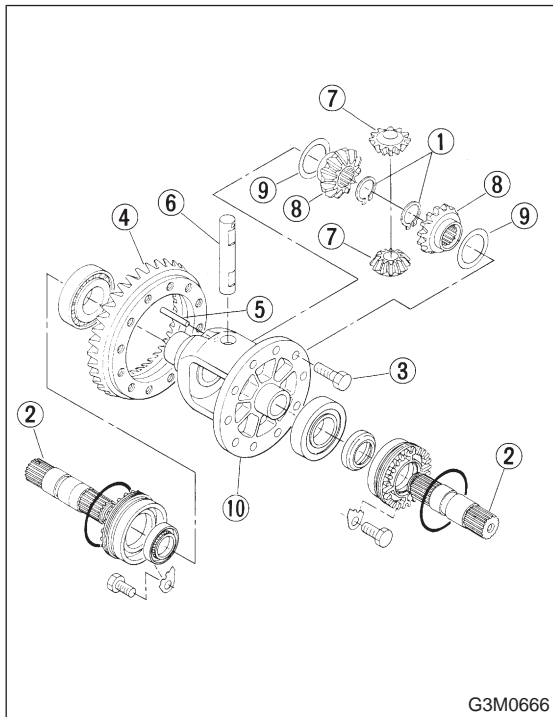

5) Install hypoid driven gear ④ to differential case ⑩ using twelve bolts ③.

Tightening torque:

$62 \pm 5 \text{ N}\cdot\text{m}$ ($6.3 \pm 0.5 \text{ kg}\cdot\text{m}$, $45.6 \pm 3.6 \text{ ft}\cdot\text{lb}$)

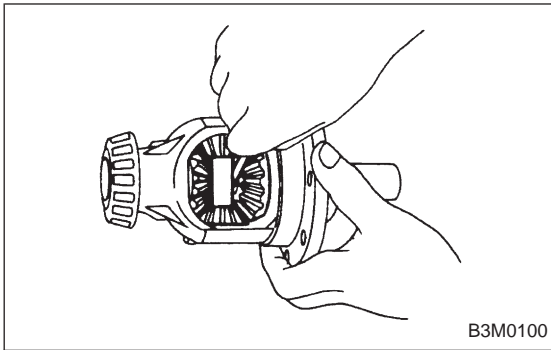

6) Position drive axle shaft in differential case and hold it with outer snap ring (28). Using a thickness gauge, measure clearance between the shaft and case is within specifications.

Clearance:

0 — 0.2 mm (0 — 0.008 in)

If it is not within specifications, replace snap ring with a suitable one.

Snap ring (Outer-28)	
Part No.	Thickness mm (in)
805028011	1.05 (0.0413)
805028012	1.20 (0.0472)