

### 3. Working Precautions

#### 1. PRECAUTIONS WHEN WORKING WITH THE PARTS MOUNTED ON THE VEHICLE

- 1) When working under a vehicle which is jacked-up, always be sure to use safety stands.
- 2) The parking brake must always be applied during working. Also, in automatic transmission vehicles, keep the select lever set to the P (Parking) range.
- 3) Be sure the workshop is properly ventilated when running the engine. Further, be careful not to touch the belt or fan while the engine is operating.
- 4) Be careful not to touch hot metal parts, especially the radiator and exhaust system immediately after the engine has been shut off.

#### 2. PRECAUTIONS IN TROUBLE DIAGNOSIS AND REPAIR OF ELECTRIC PARTS

- 1) The battery cable must be disconnected from the battery's (-) terminal, and the ignition switch must be set to the OFF position, unless otherwise required by the diagnostics.
- 2) Securely fasten the wiring harness with clamps and slips so that the harness does not interfere with the body end parts or edges and bolts or screws.
- 3) When installing parts, be careful not to catch them on the wiring harness.

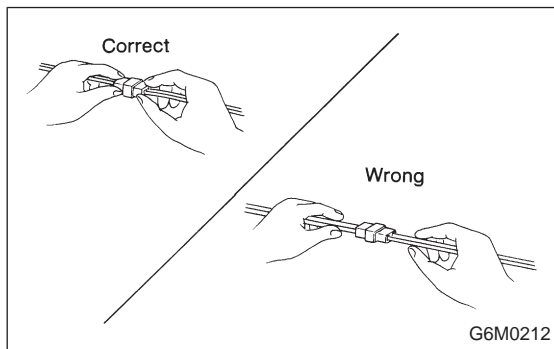

- 4) When disconnecting a connector, do not pull the wires, but pull while holding the connector body.

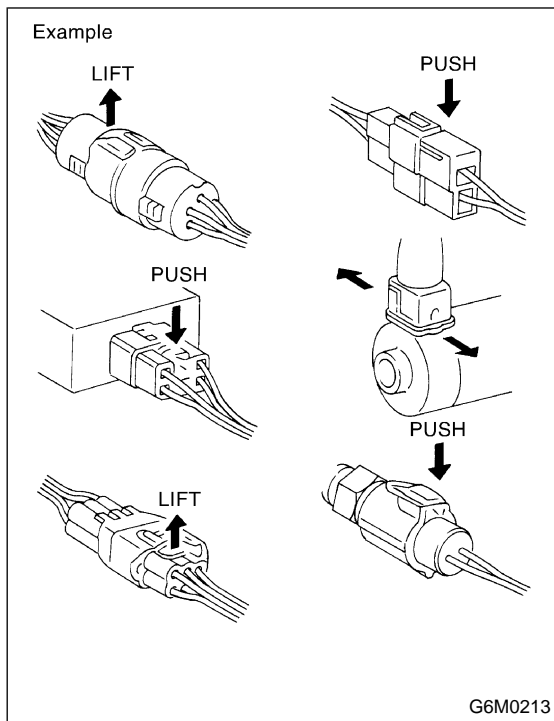

5) Some connectors are provided with a lock. One type of such a connector is disconnected by pushing the lock, and the other, by moving the lock up. In either type the lock shape must be identified before attempting to disconnect the connector.

To connect, insert the connector until it snaps and confirm that it is tightly connected.

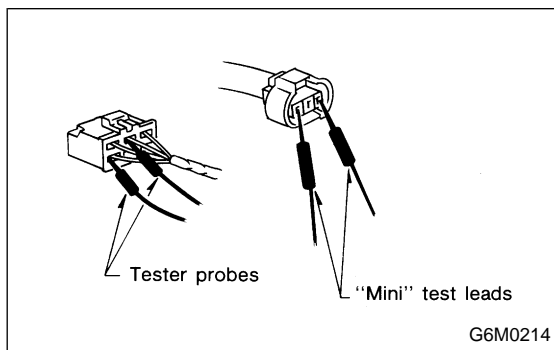

6) When checking continuity between connector terminals, or measuring voltage across the terminal and ground, always contact tester probe(s) on terminals from the wiring connection side. If the probe is too thick to gain access to the terminal, use "mini" test leads.

To check water-proof connectors (which are not accessible from the wiring side), contact test probes on the terminal side being careful not to bend or damage the terminals.

7) Sensors, relays, electrical unit, etc., are sensitive to strong impacts.

Handle them with care so that they are not dropped or mishandled.

**ABBREVIATION LIST**

| Abbr.   | Full name                        |
|---------|----------------------------------|
| A.B.S.  | Antilock Brake System            |
| ACC     | Accessory                        |
| A/C     | Air Conditioning                 |
| AD      | Auto Down                        |
| AT      | Automatic Transmission           |
| AU      | Auto Up                          |
| +B      | Battery                          |
| DN      | Down                             |
| DRL     | Daytime Running Light            |
| E       | Ground                           |
| F/B     | Fuse & Joint Box                 |
| FL1.5   | Fusible link 1.5 mm <sup>2</sup> |
| IG      | Ignition                         |
| Illumi. | Illumination                     |

| Abbr. | Full name                        |
|-------|----------------------------------|
| LH    | Left Hand                        |
| Lo    | Low                              |
| M     | Motor                            |
| M/B   | Main Fuse Box                    |
| MG    | Magnet                           |
| Mi    | Middle                           |
| MPFI  | Multi Point Fuel Injection Model |
| OP    | Optional Parts                   |
| PASS  | Passing                          |
| RH    | Right Hand                       |
| SBF   | Slow Blow Fuse                   |
| ST    | Starter                          |
| SW    | Switch                           |
| UP    | Up                               |
| WASH  | Washer                           |