

5. Wiring Diagram

1. POWER SUPPLY ROUTING

- Battery current
- Current from ignition switch IG terminal
- - - Current from ignition switch ACC terminal
- Other currents

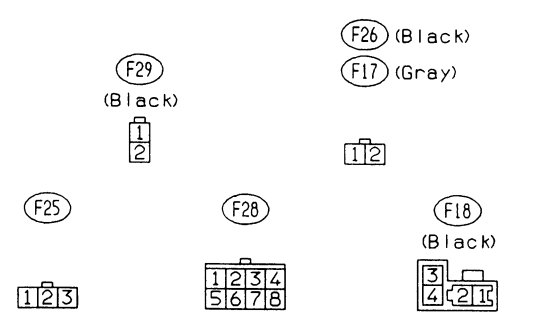

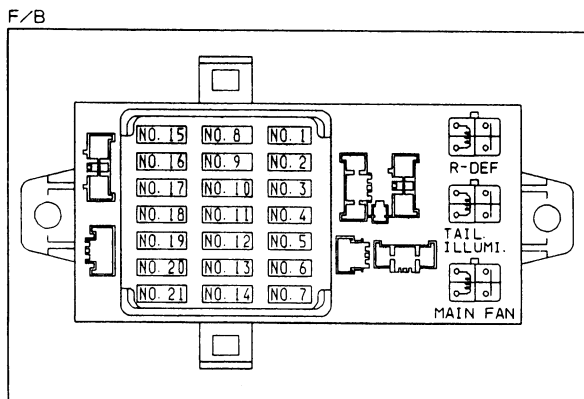
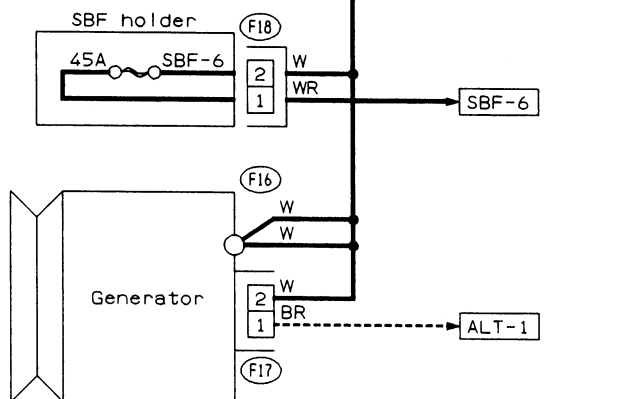
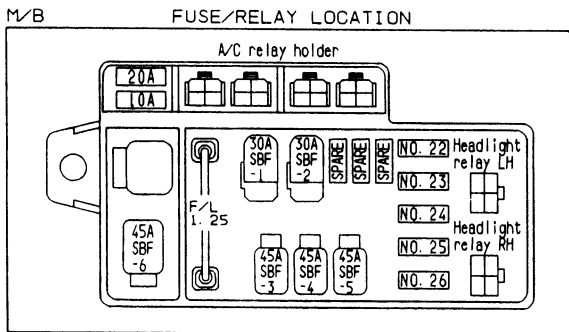
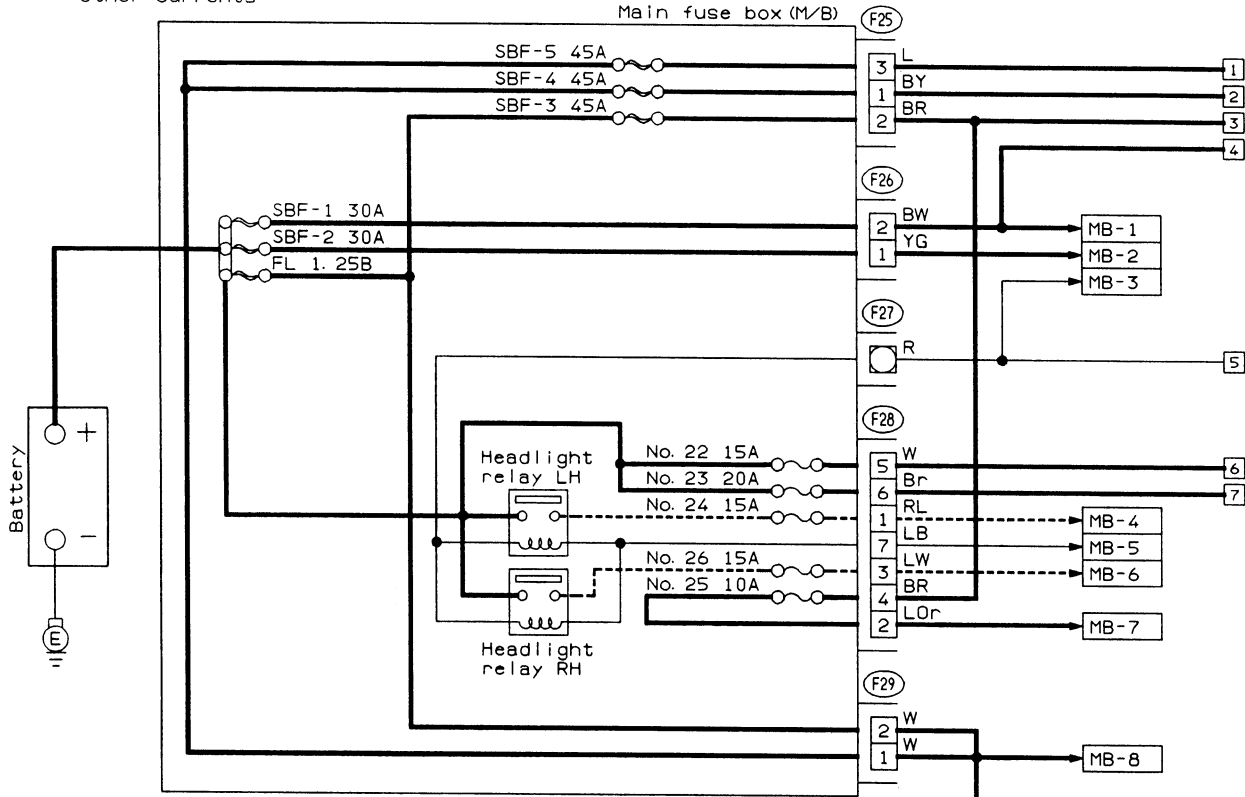
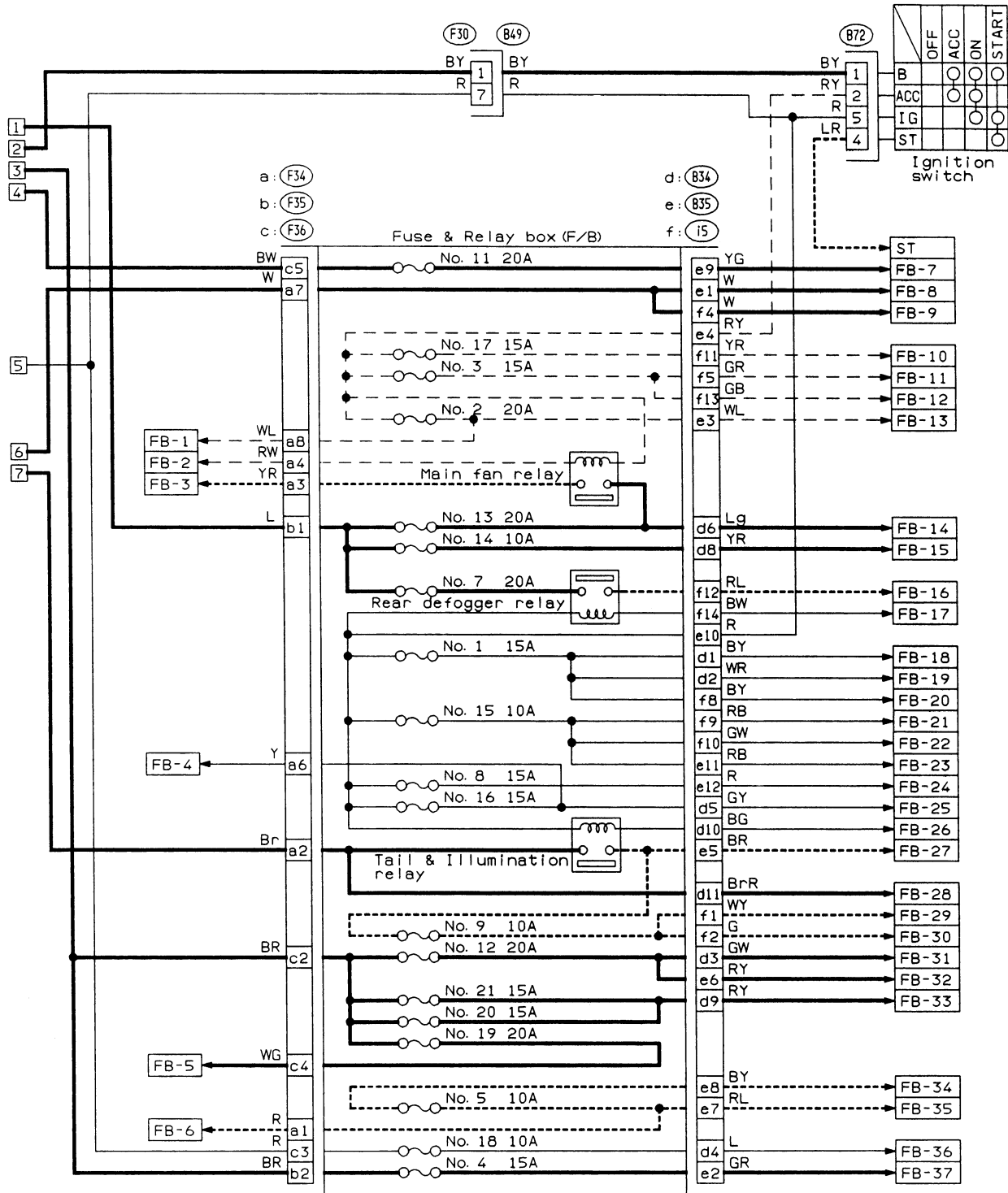

- (F30)
- (B72)
(Black)
- (F34)
(Gray)
- (F35)
(Gray)
- (F36)
(Gray)
- (B34)
(Gray)
- (B35)
(Gray)
- (i5)
(Gray)

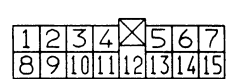
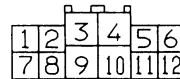
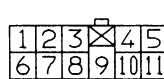
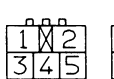
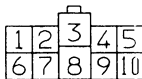
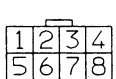

5. Wiring Diagram

No.	LOAD: SYSTEM No.
MB-1	P/W CIRCUIT BREAKER: 21, 31
MB-2	MAIN RELAY: 13 FUEL PUMP RELAY: 13
MB-3	A/C FUSE: 3, 22
MB-4	HEADLIGHT LH: 17
MB-5	DIODE (LIGHTING): 17 LIGHTING SWITCH: 17 DRL CONTROL MODULE: 17
MB-6	HEADLIGHT RH: 17 COMBINATION METER: 17
MB-7	RADIO: 7 SPOT LIGHT: 27 COMBINATION METER: 27 FUSE BOX ILLUMINATION: 27 ROOM LIGHT: 27 LUGGAGE ROOM LIGHT: 27 TRUNK LOOM LIGHT: 27
MB-8	A/C FUSE: 22
SBF-6	HYDRAULIC UNIT: 4
ALT-1	COMBINATION METER: 9, 20 DRL CONTROL MODULE: 17
ST	AT CONTROL MODULE: 5 INHIBITOR SWITCH: 13, 17, 29 ENGINE CONTROL MODULE: 13 STARTER INTERLOCK RELAY: 17, 29
FB-1	FRONT WASHER MOTOR: 14
FB-2	DIODE (A/C): 22
FB-3	MAIN FAN MOTOR: 22
FB-4	AT CONTROL MODULE: 5 FUEL PUMP RELAY: 13 ENGINE CONTROL MODULE: 13 IGNITION COIL: 13
FB-5	HYDRAULIC UNIT: 4 MAIN FAN MOTOR: 22
FB-6	FRONT CLEARANCE LIGHT LH. RH: 18
FB-7	DOOR LOCK TIMER: 12
FB-8	AT SHIFT LOCK CONTROL MODULE: 6 KEY WARNING SWITCH: 6, 26
FB-9	HAZARD SWITCH: 32
FB-10	RADIO: 7
FB-11	CIGARETTE LIGHTER: 16
FB-12	REMOTE CONTROLLED REARVIEW MIRROR SWITCH: 25
FB-13	AT SHIFT LOCK CONTROL MODULE: 6 FRONT WIPER MOTOR: 14 FRONT WIPER SWITCH: 14 REAR WASHER MOTOR: 24 REAR WIPER RELAY: 24 REAR WIPER MOTOR: 24

No.	LOAD: SYSTEM No.
FB-14	MAIN FAN RELAY 2: 22
FB-15	AT CONTROL MODULE: 5 ENGINE CONTROL MODULE: 13
FB-16	REAR DEFOGGER: 23
FB-17	COMBINATION METER: 23 REAR DEFOGGER SWITCH: 23
FB-18	BACK-UP LIGHT SWITCH: 8 INHIBITOR SWITCH: 8
FB-19	AT SHIFT LOCK CONTROL MODULE: 6
FB-20	HAZARD SWITCH: 32
FB-21	MODE CONTROL PANEL: 3 COMBINATION METER: 4, 5, 9, 13, 15, 19, 20, 26 SEAT BELT TIMER: 26
FB-22	COMBINATION METER: 28
FB-23	FRESH/RECIRC ACTUATOR: 3 EVAPORATION THERMOSWITCH: 3 BLOWER MOTOR RELAY: 3 CHECK CONNECTOR: 4, 5, 11, 13, 28 DRL CONTROL MODULE: 17 DRL RELAY: 17 DRL HI-BEAM RELAY: 17 P/W AND SUNROOF RELAY: 21, 31
FB-24	AIRBAG CONTROL MODULE: 28
FB-25	AIRBAG CONTROL MODULE: 28
FB-26	LIGHTING SWITCH: 18
FB-27	PARKING LIGHT SWITCH: 18
FB-28	PARKING LIGHT SWITCH: 18
FB-29	COMBINATION METER: 5, 18 ILLUMINATION LIGHTS: 18
FB-30	ILLUMINATION CONTROL MODULE: 18 ILLUMINATION LIGHTS: 18
FB-31	STOP LIGHT SWITCH: 5, 6, 11, 30
FB-32	HORN RELAY: 11, 16
FB-33	BLOWER MOTOR RELAY: 3
FB-34	PARKING LIGHT SWITCH: 18
FB-35	REAR COMBINATION LIGHT LH. RH: 18 LICENSE PLATE LIGHT LH. RH: 18
FB-36	A.B.S. G SENSOR: 14 A.B.S. CONTROL MODULE: 4 CRUISE CONTROL MODULE: 11 CRUISE CONTROL MAIN SWITCH: 11

2. GROUND DISTRIBUTION

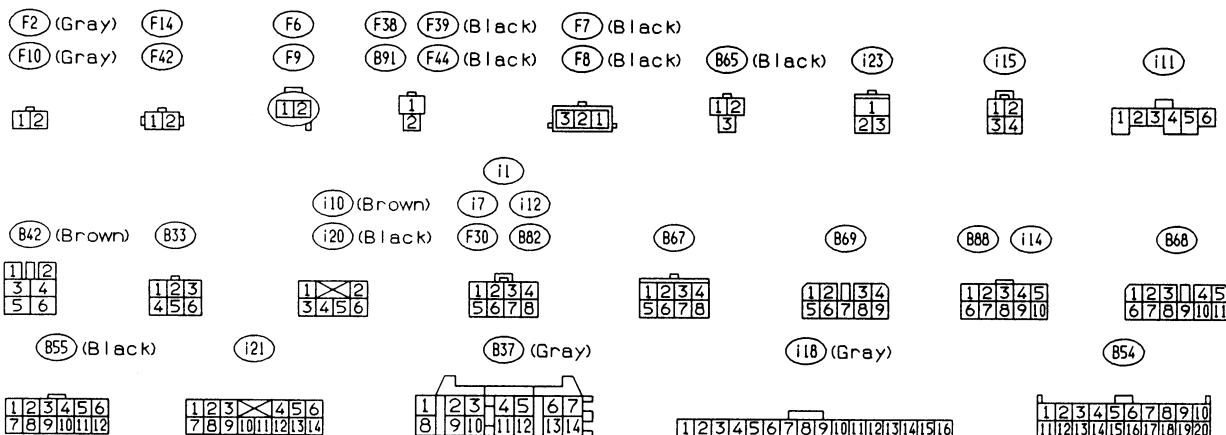
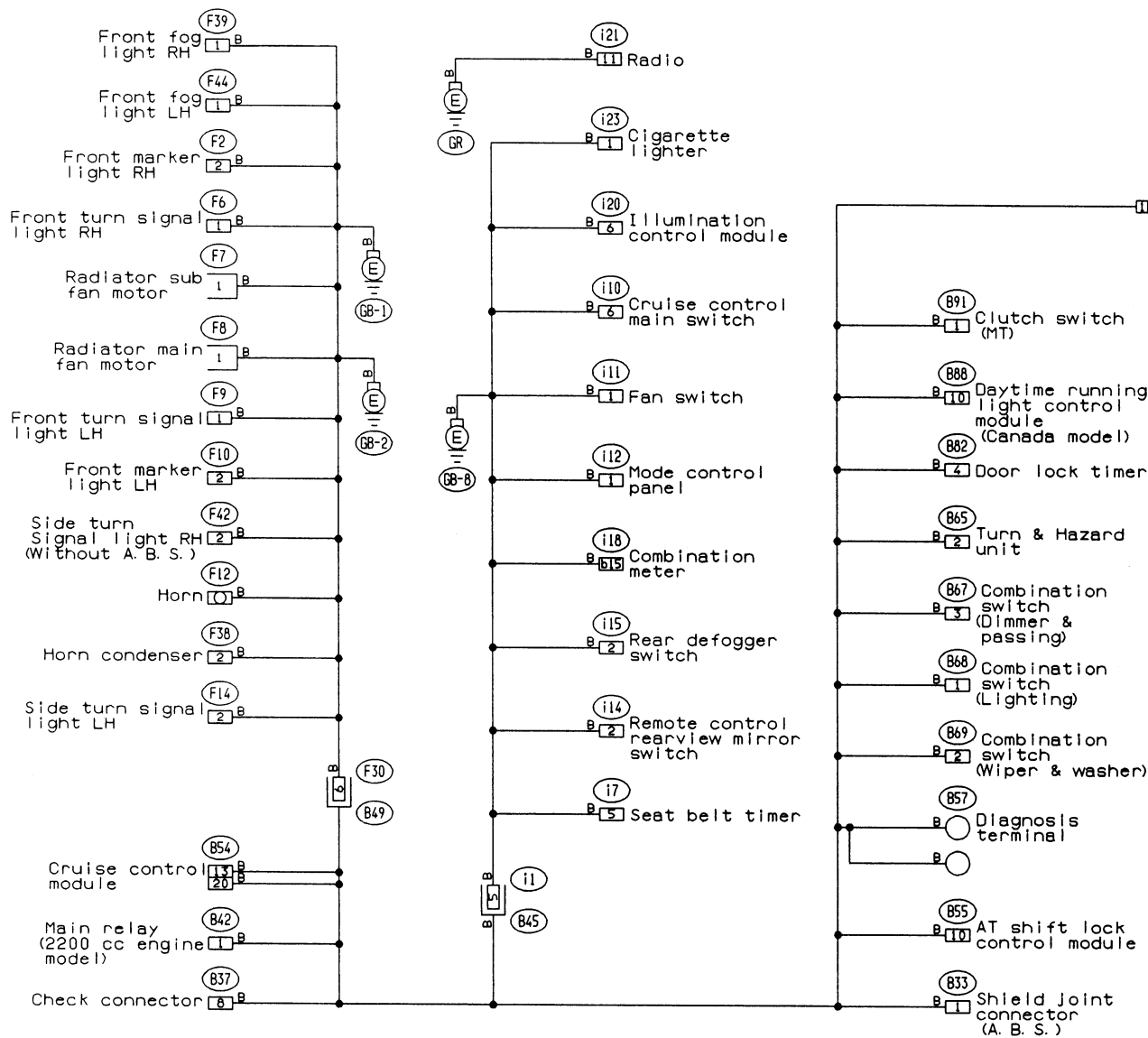

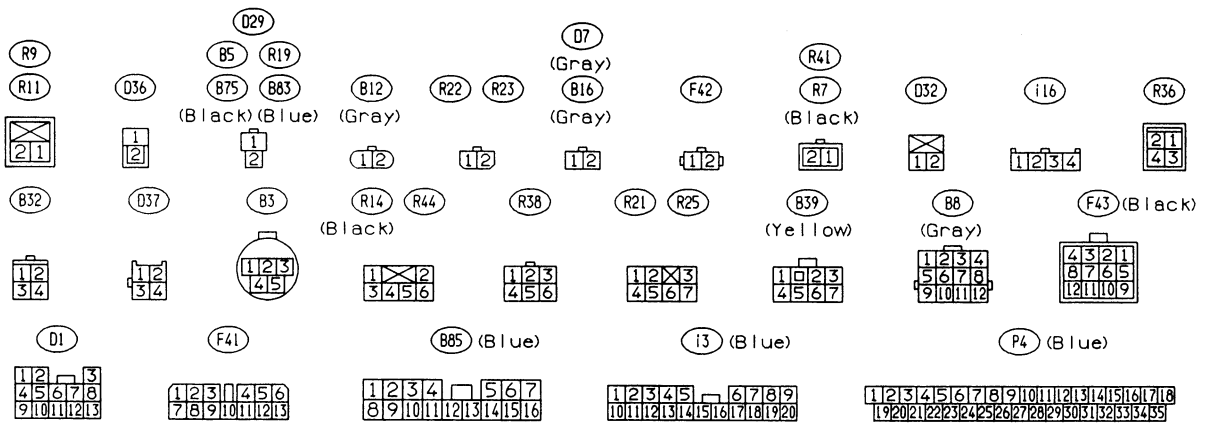
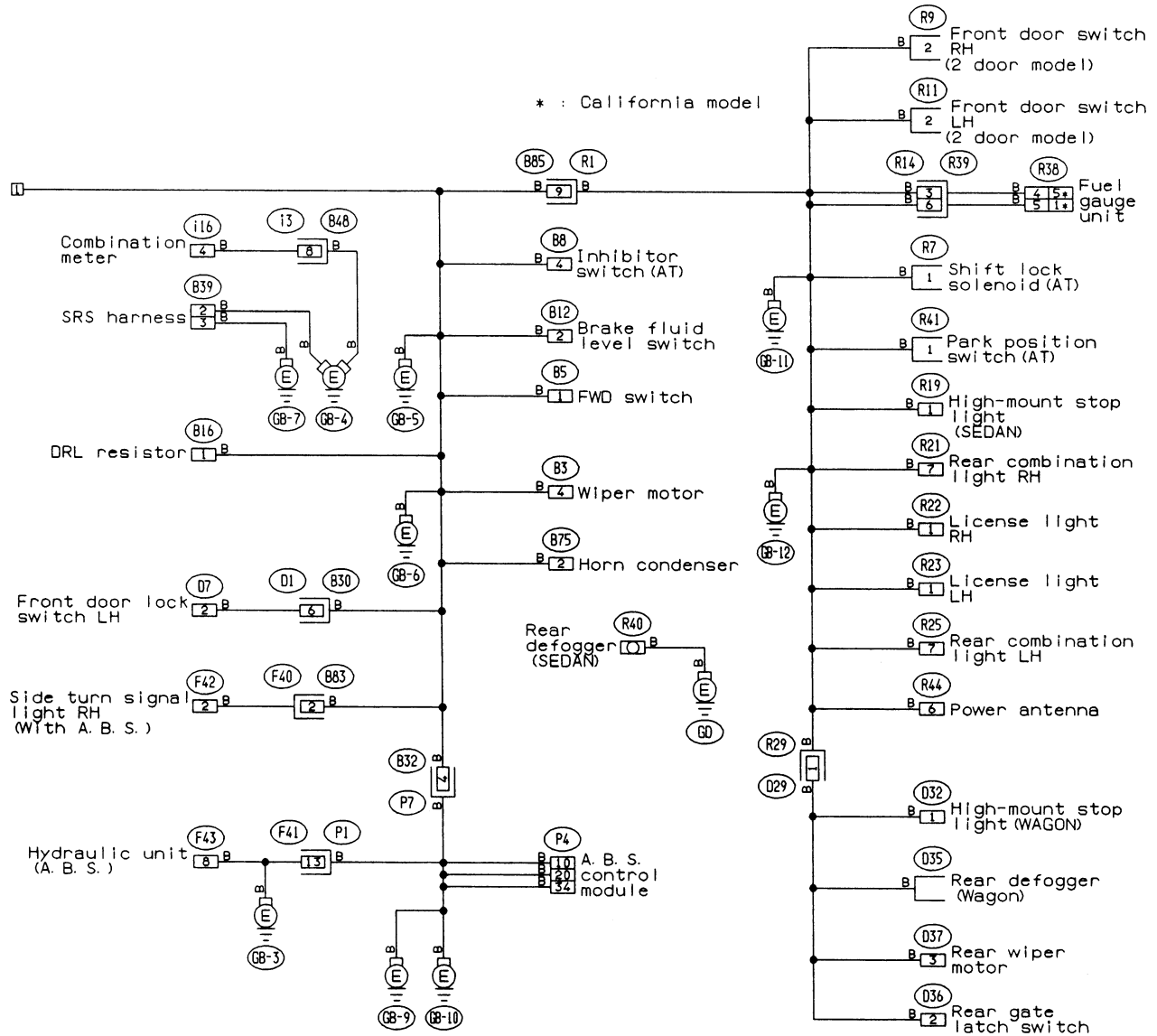

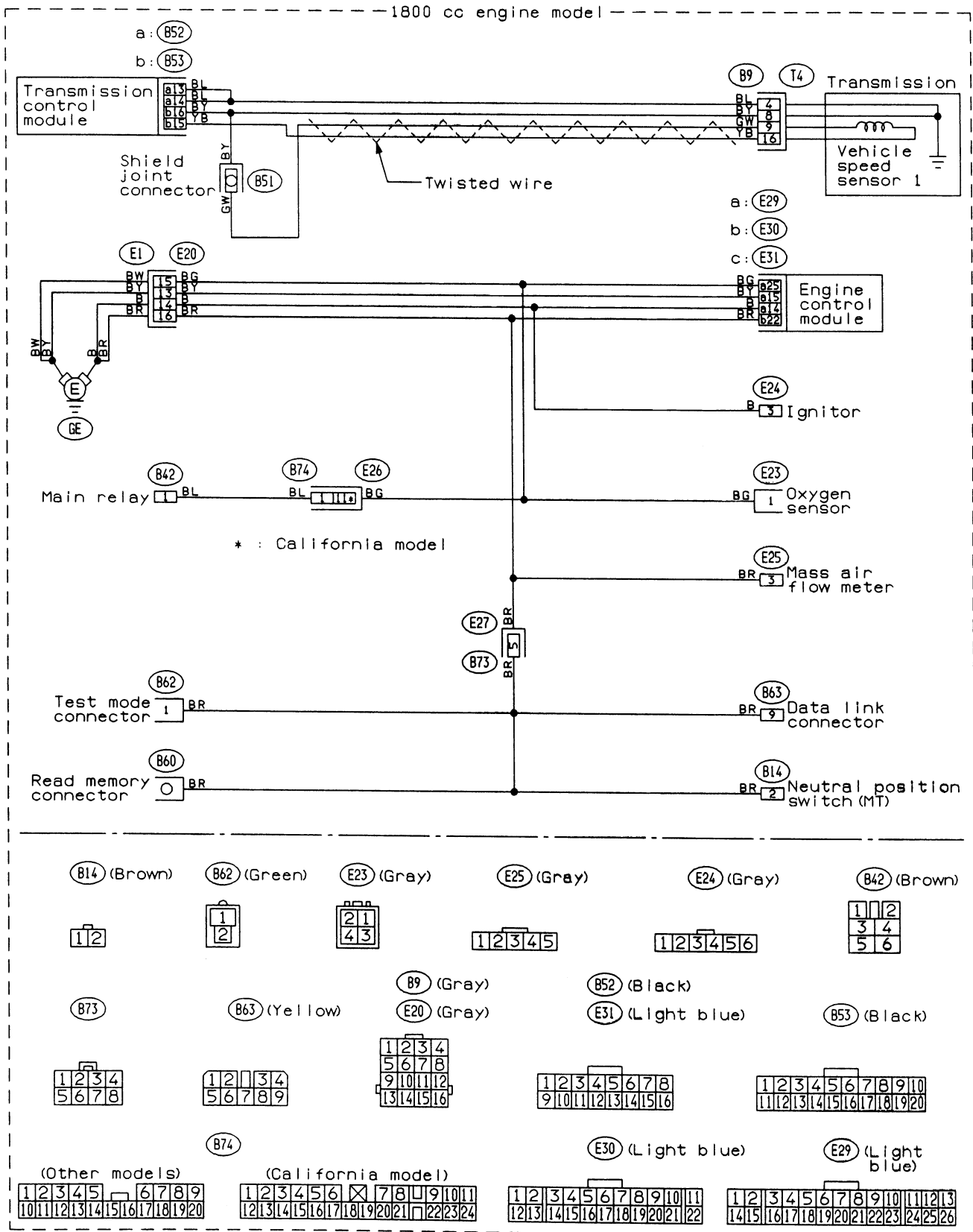

5. Wiring Diagram

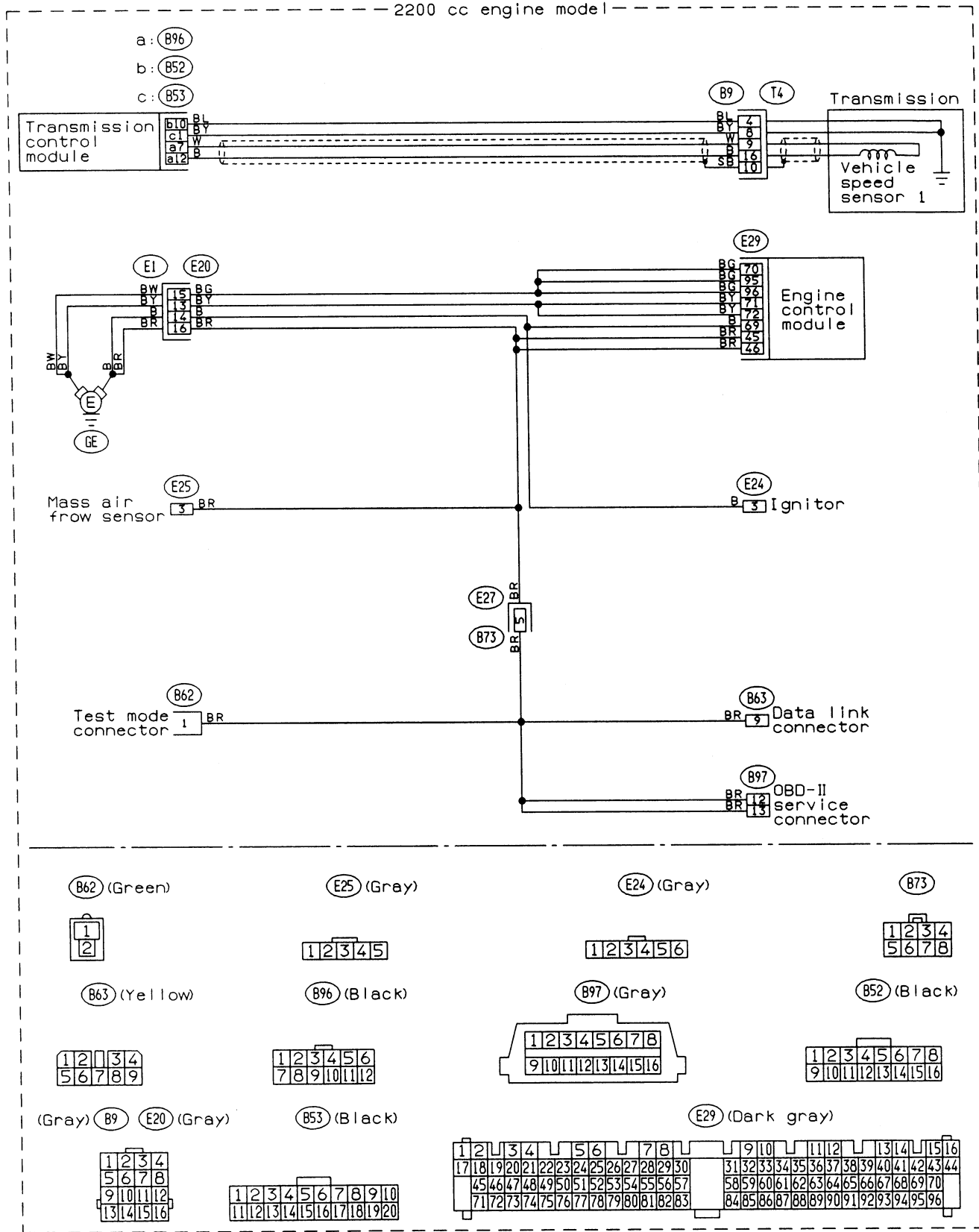

3. AIR CONDITIONING SYSTEM

• With A/C

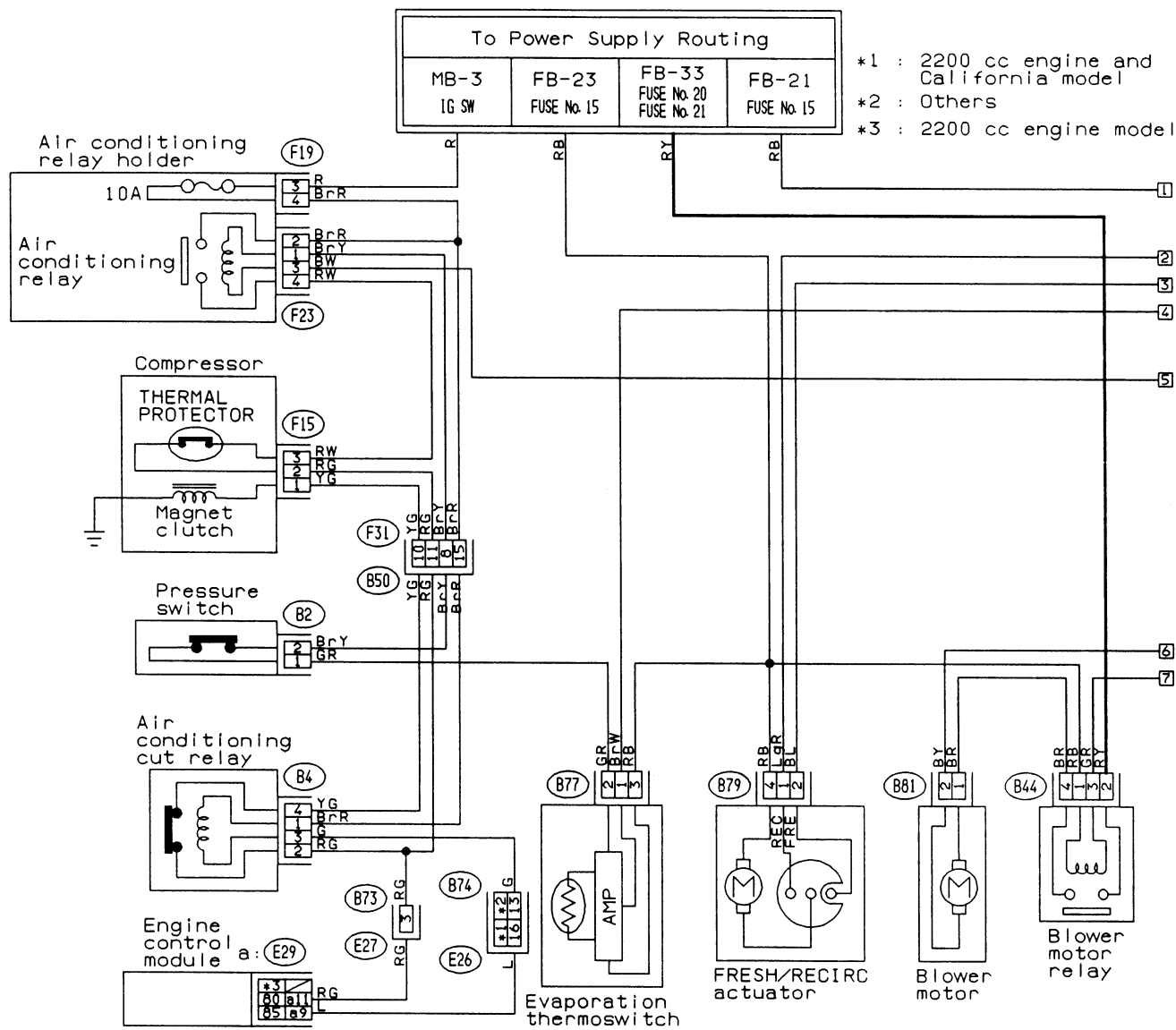

- *1 : 2200 cc engine and California model
- *2 : Others
- *3 : 2200 cc engine model

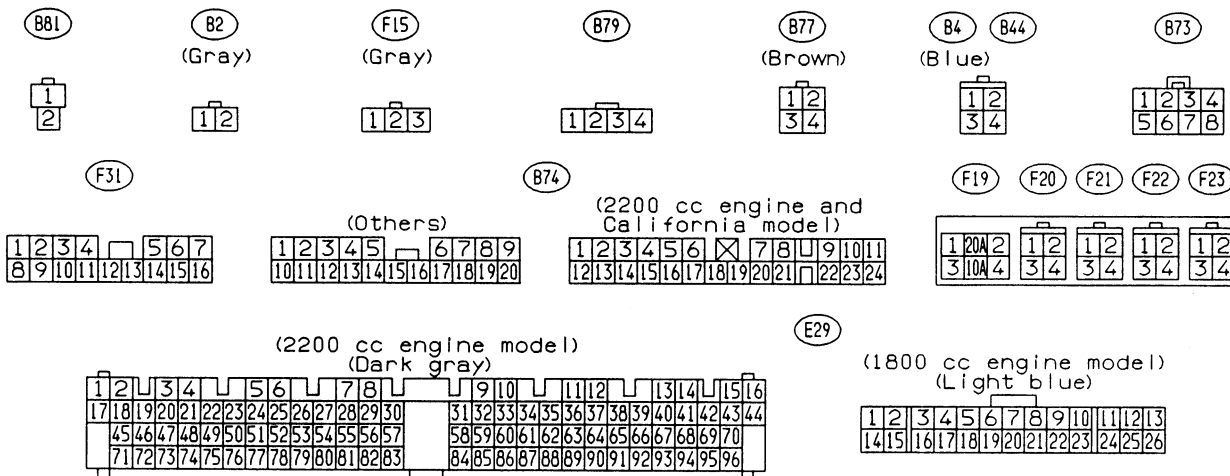

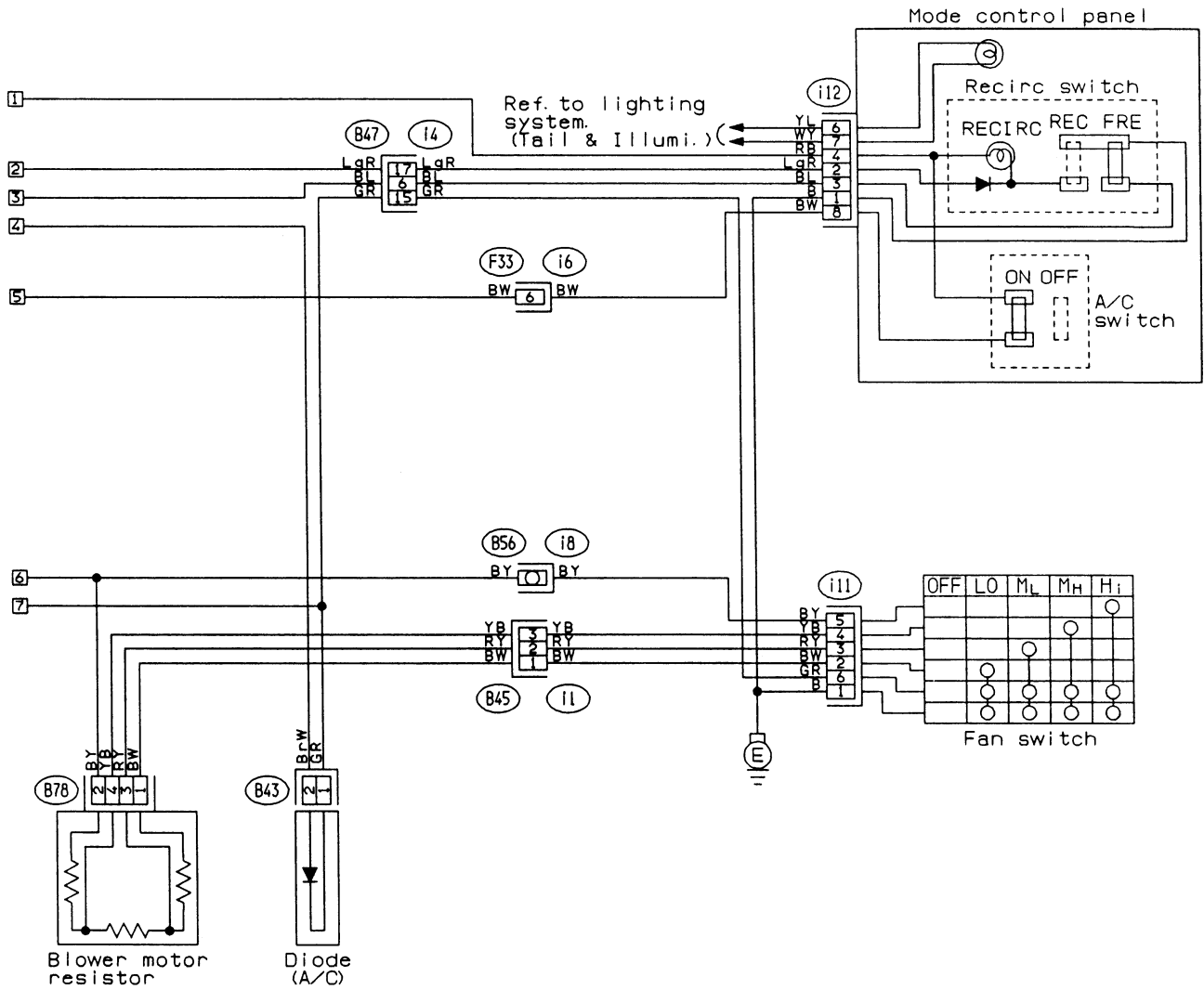

(B43) (Black)



(B78)



(F33) (Black)

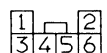

(i11)

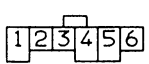

(i1) (i12)



(i4)

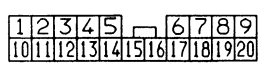

3. AIR CONDITIONING SYSTEM

- Without A/C

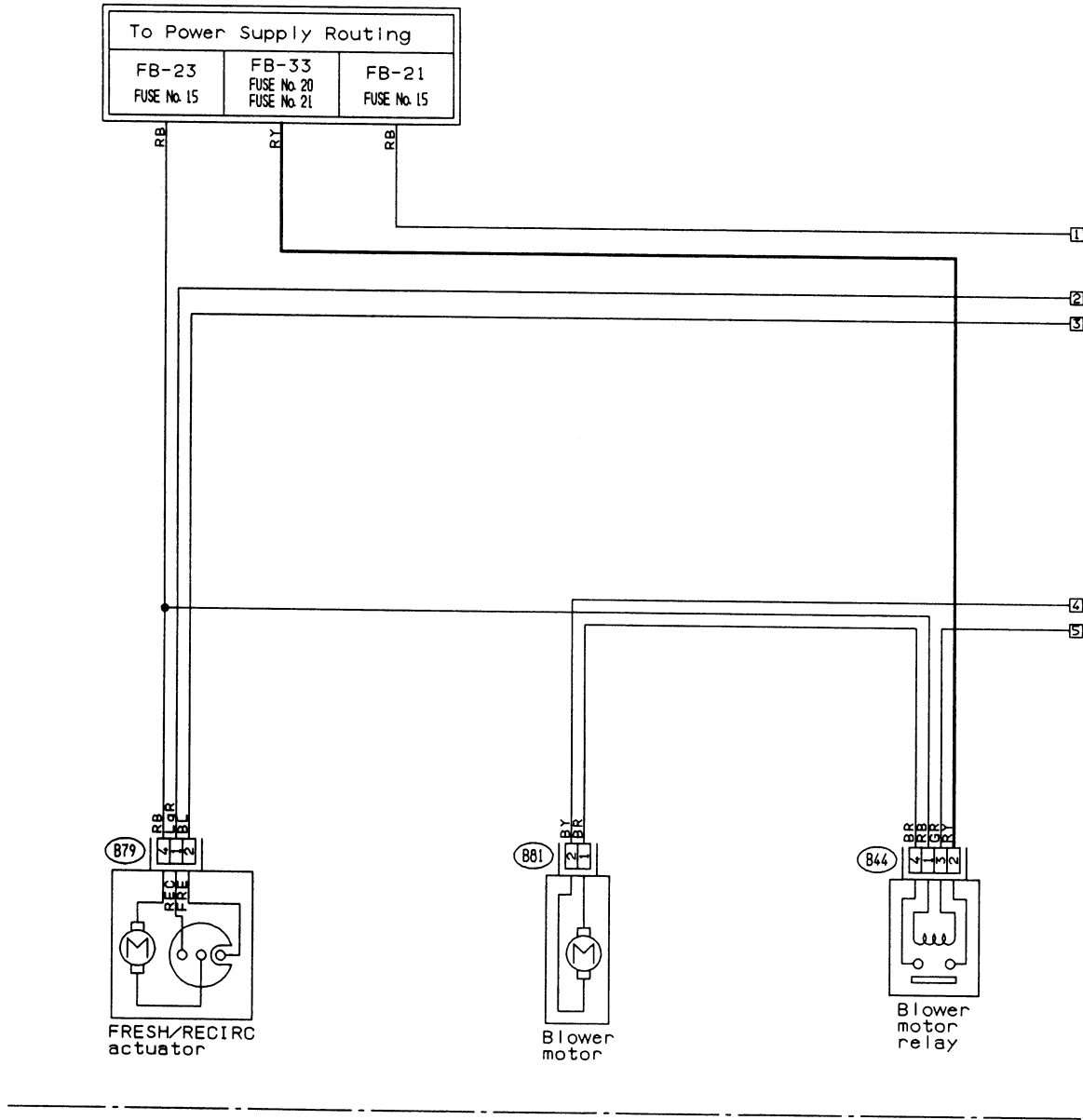

(B81)



(B79)



(B44)



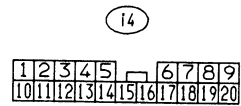
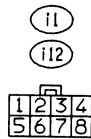
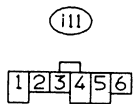
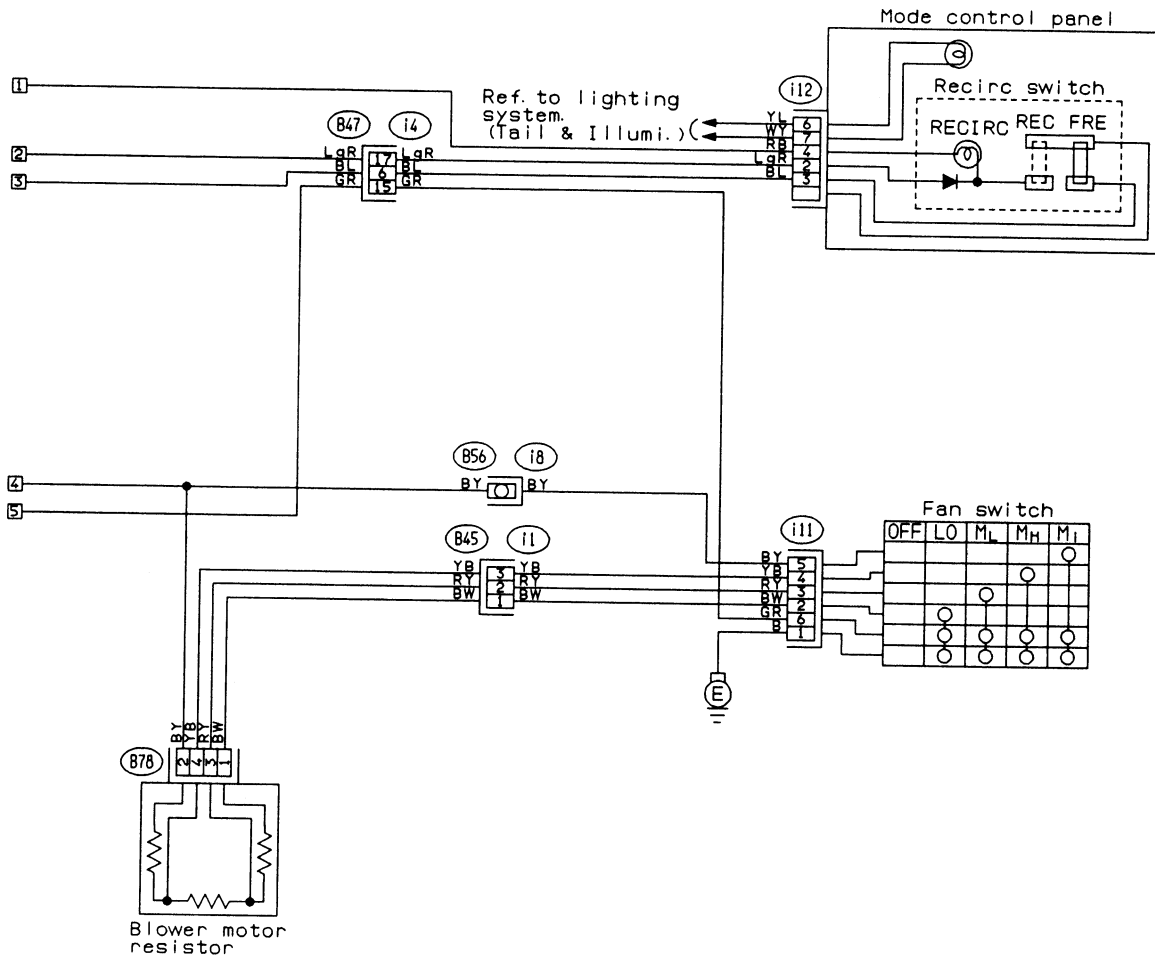

4. ANTI-LOCK BRAKE SYSTEM

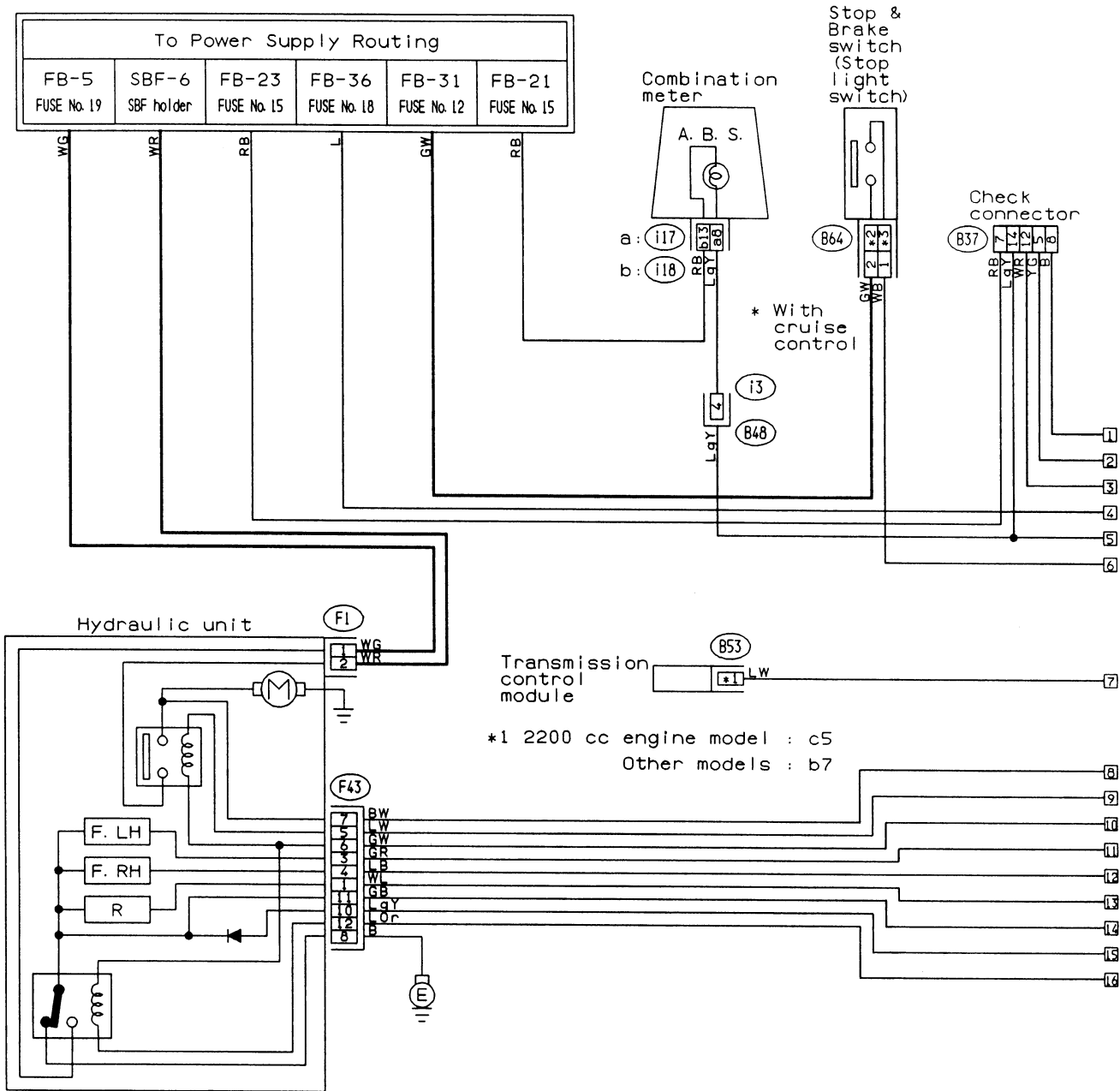

(Gray) (F1) (B94) (Black) (B64) (Black) (F43) (Black) (B53) (Black)

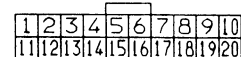
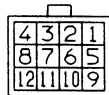
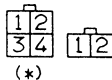

(i3) (Blue)

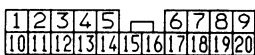

(B37) (Gray)



(Gray) (i17) (i18) (Gray)

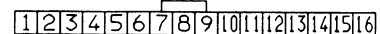

5. Wiring Diagram

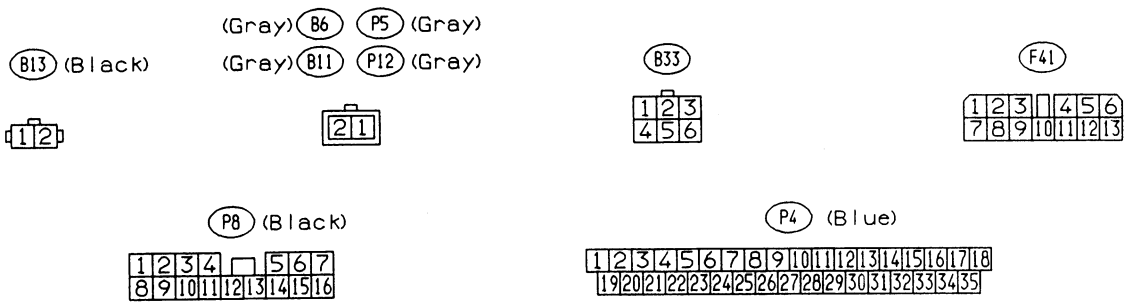
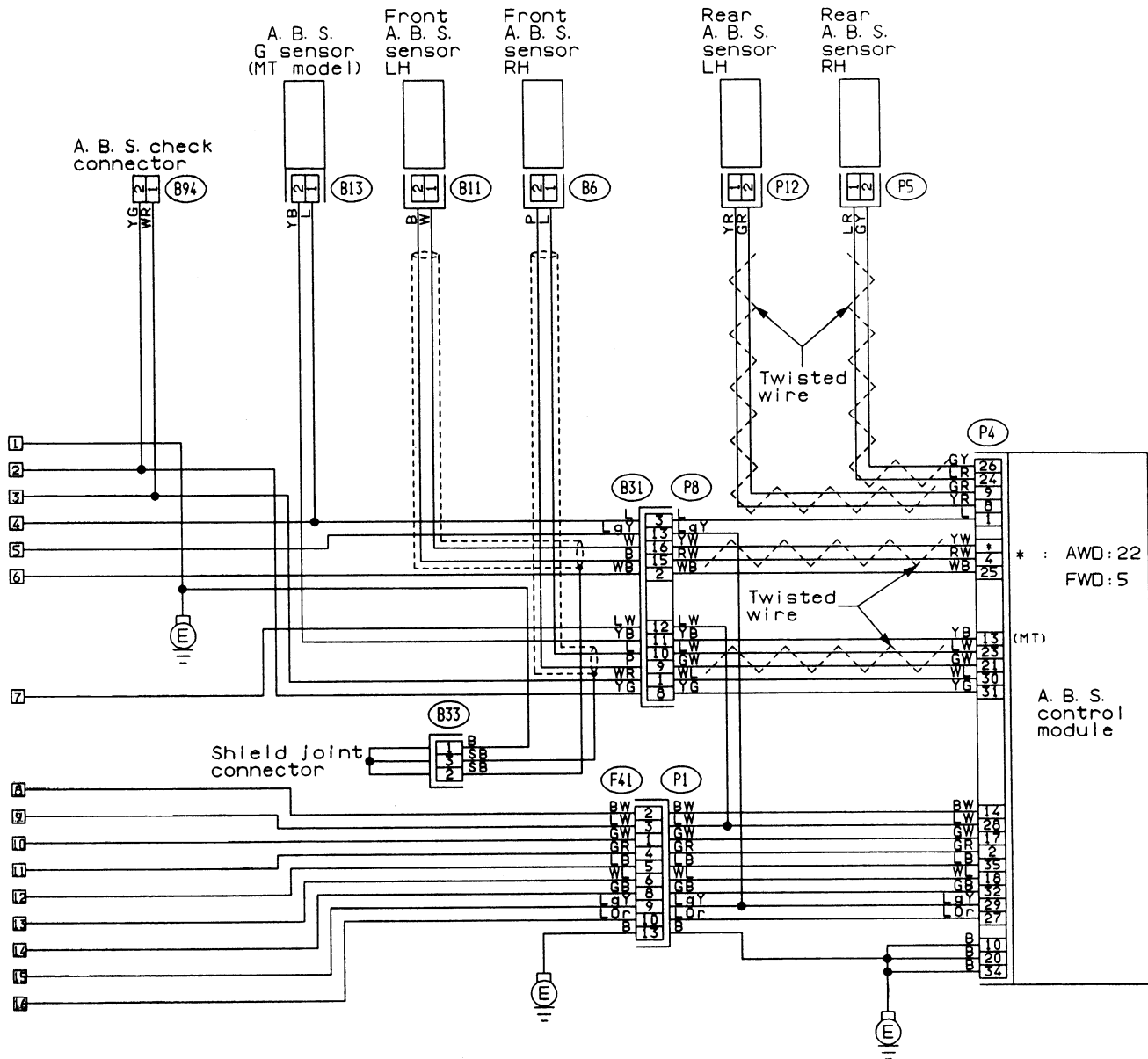

5. Wiring Diagram

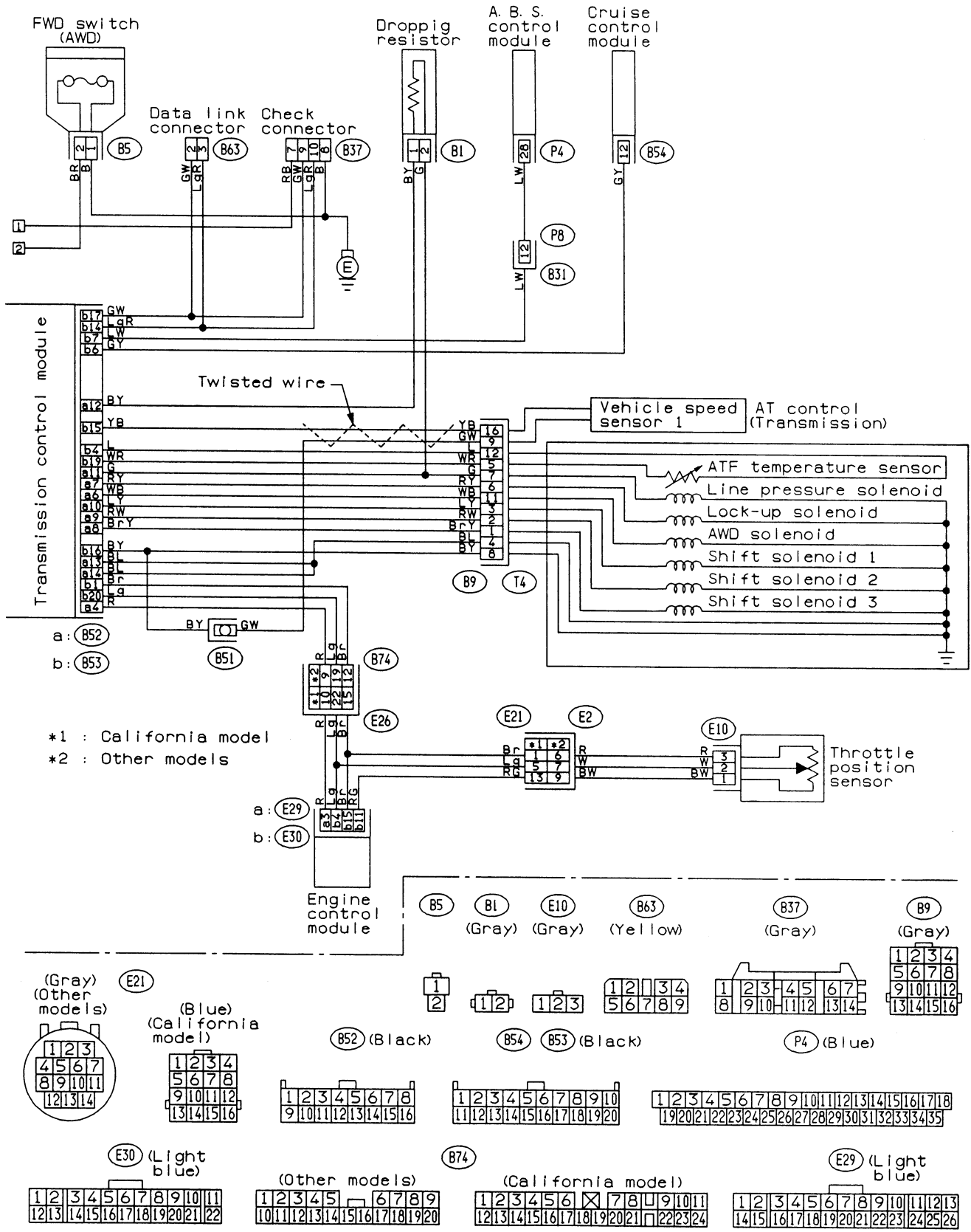

5. A/T CONTROL SYSTEM

● 2200 cc engine model

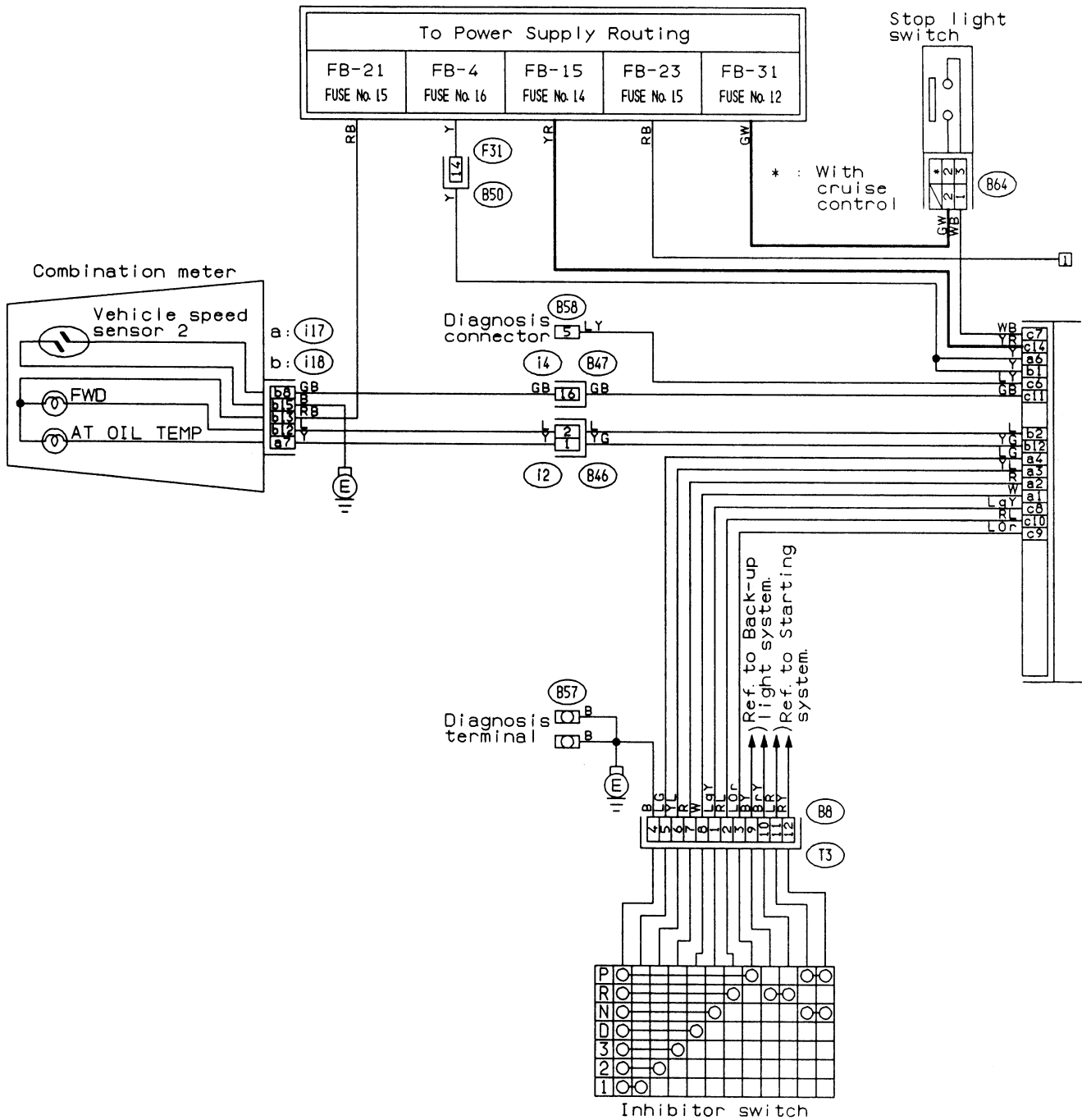

(B64) (Black)

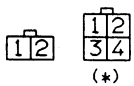

(Gray) (i17) (i18) (Gray)

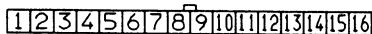

(B58) (Black)



(F31)

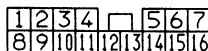

(i2) (Black)

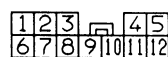

(14)

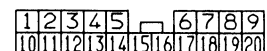

(B8) (Gray)

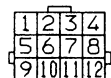



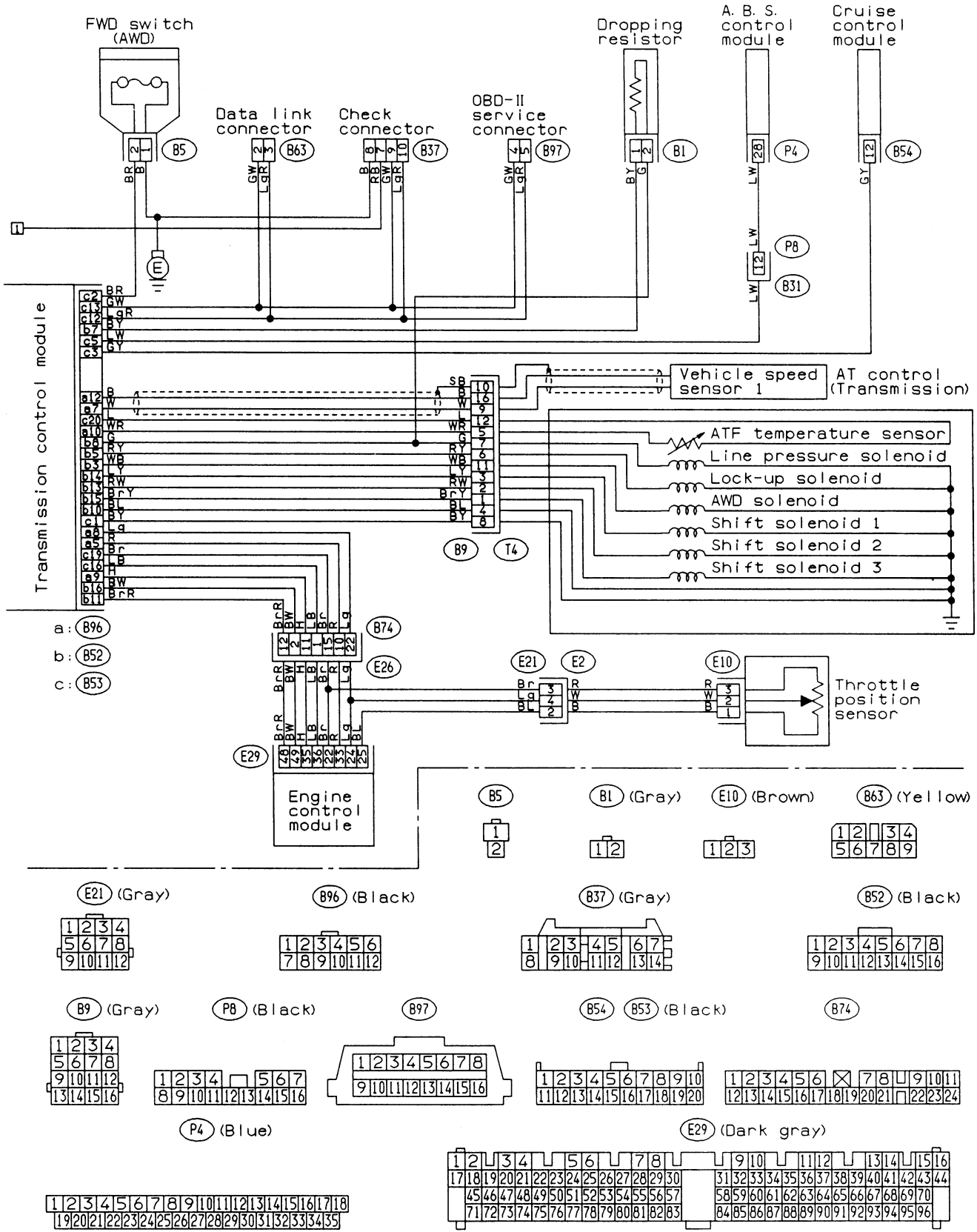

5. Wiring Diagram

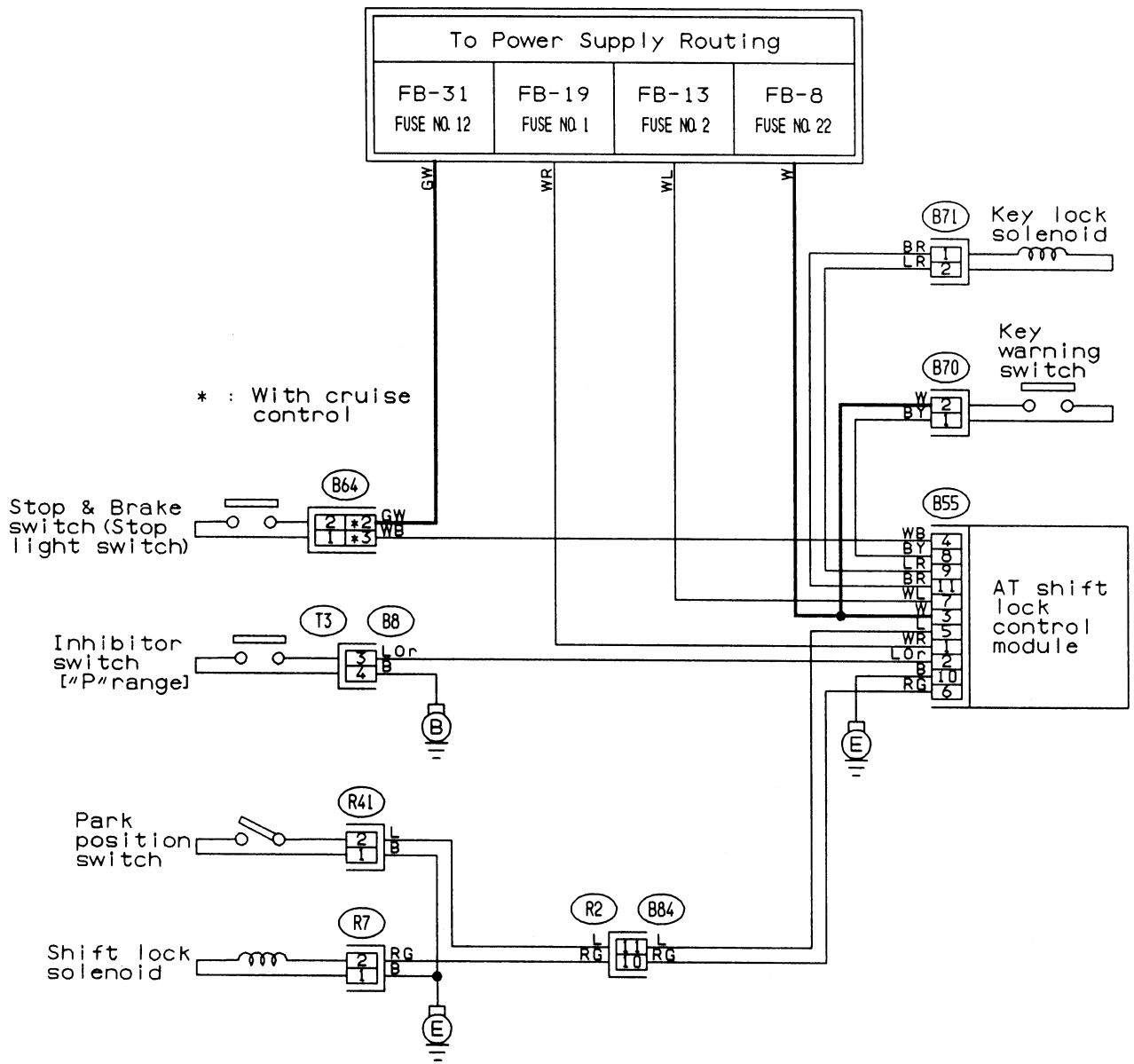

6. A/T SHIFT LOCK SYSTEM

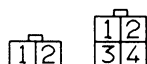

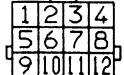
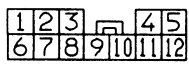
- (B70) (Black) (R41) (R7) (Black) (B71) (Black) (B64) (Black)
-    
- (*)
- (B55) (Black) (B8) (Gray) (B84) (Black)
-   

7. AUDIO SYSTEM

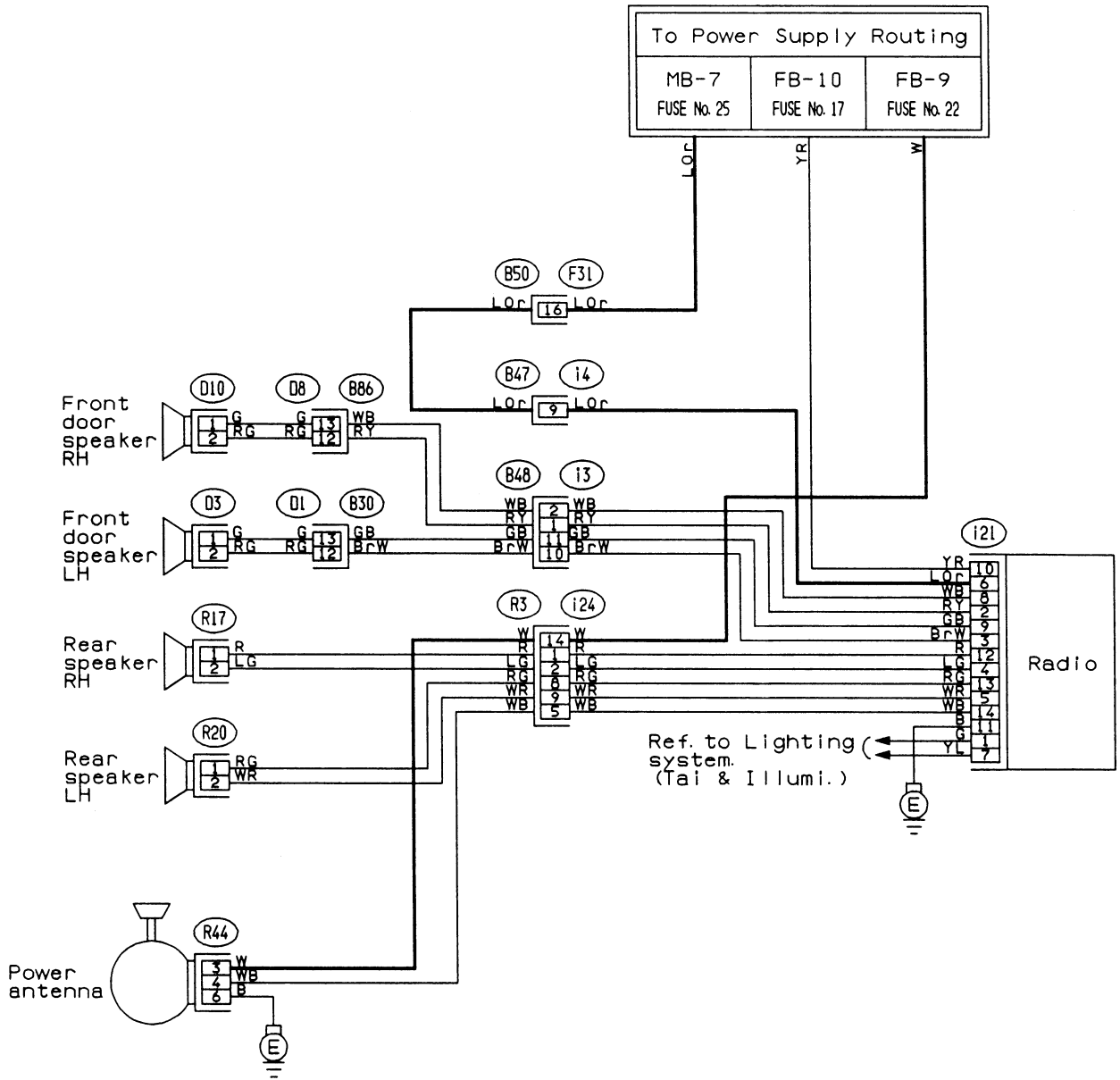

D3 D10



R17 R20



Wagon

Sedan (Black)

R44

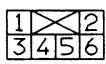

D1 D8

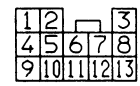

i21

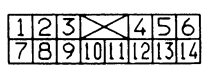

i24 F31

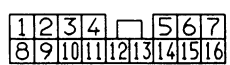

i4 i3 (Blue)

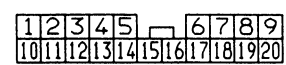

8. BACK-UP LIGHT SYSTEM

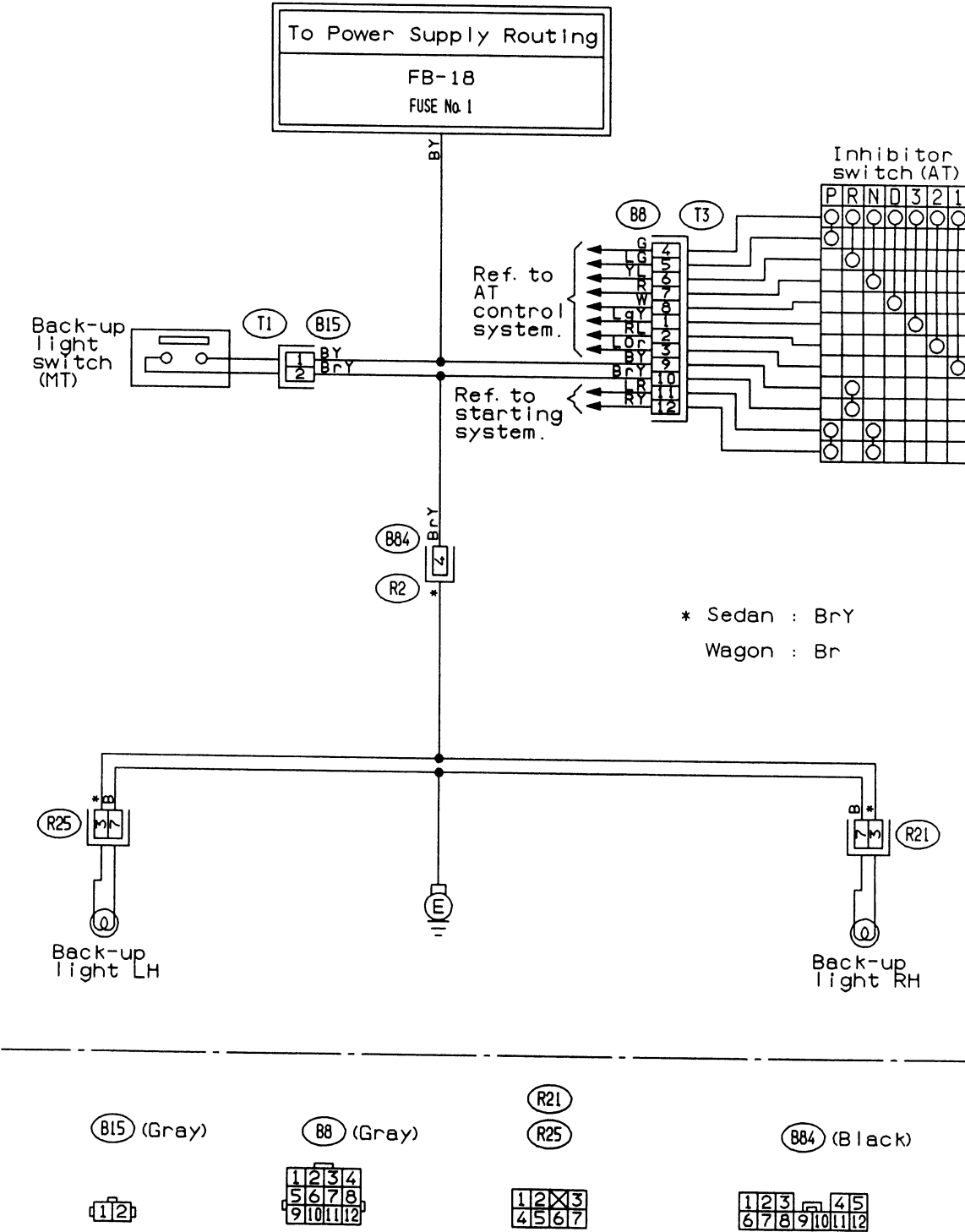

GU29-01

9. CHARGING SYSTEM

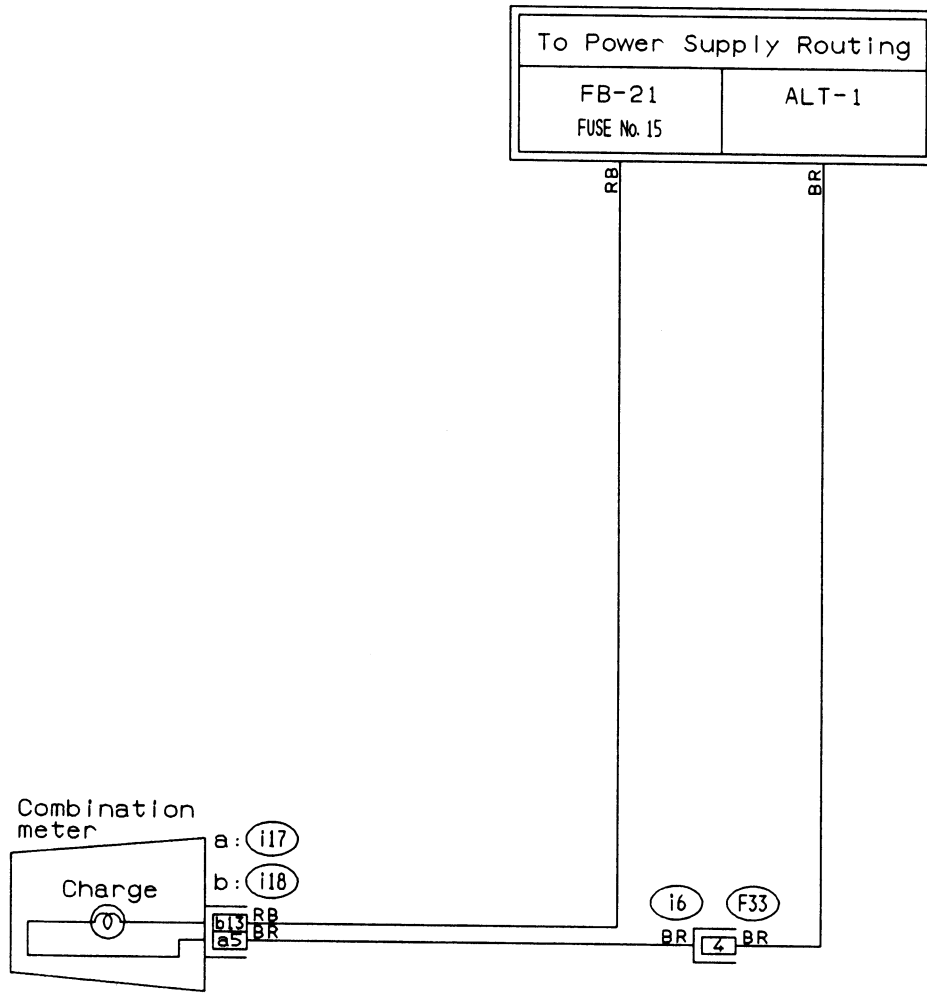

F33 (Black)

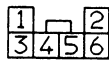

i17 (Gray)

i18 (Gray)

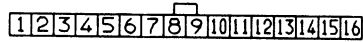

10. COMBINATION METER

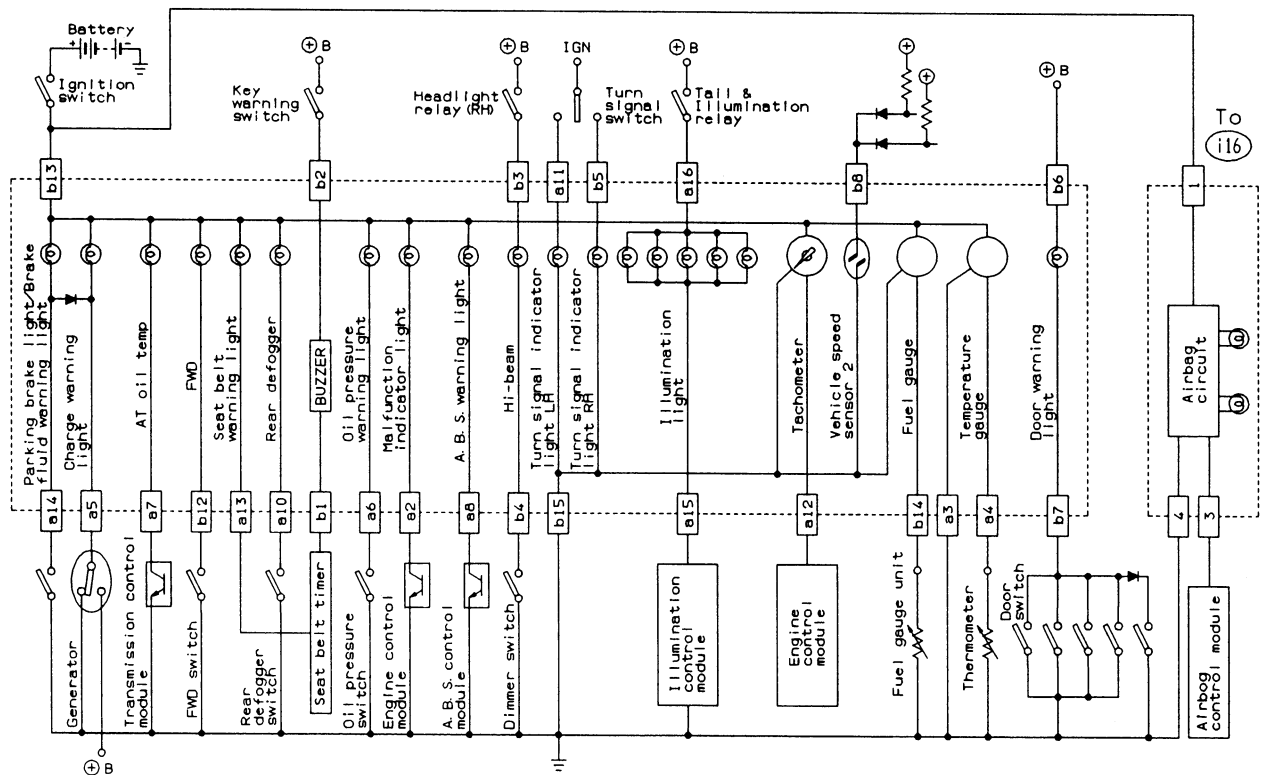
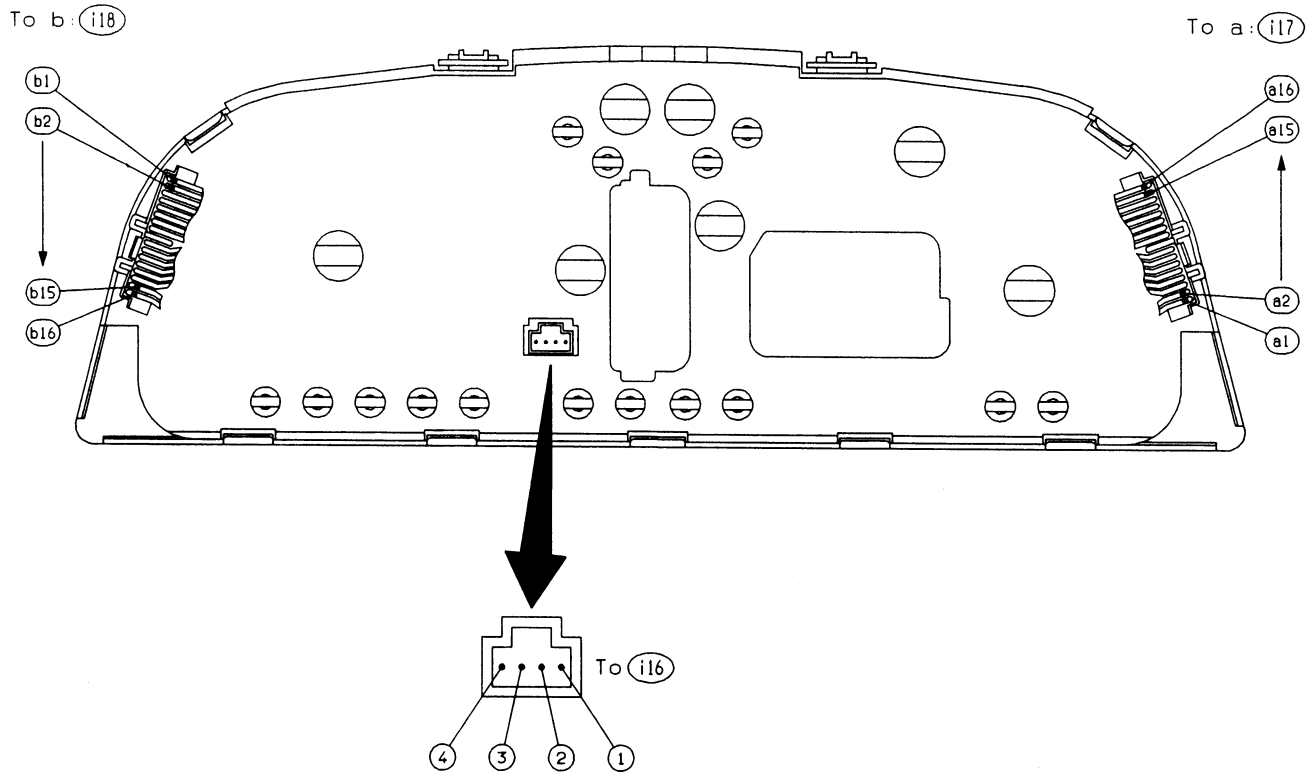

11. CRUISE CONTROL SYSTEM

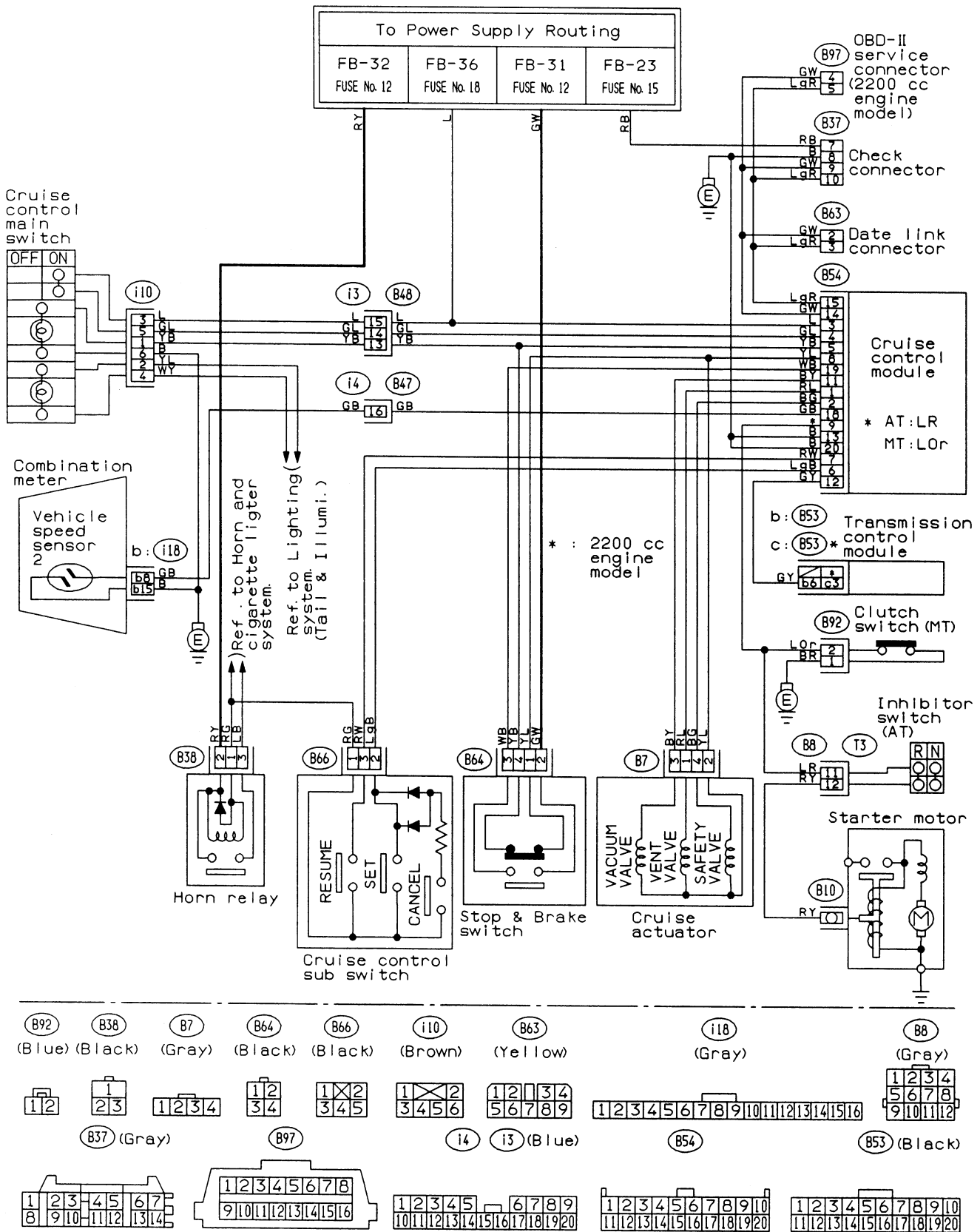

12. DOOR LOCK SYSTEM

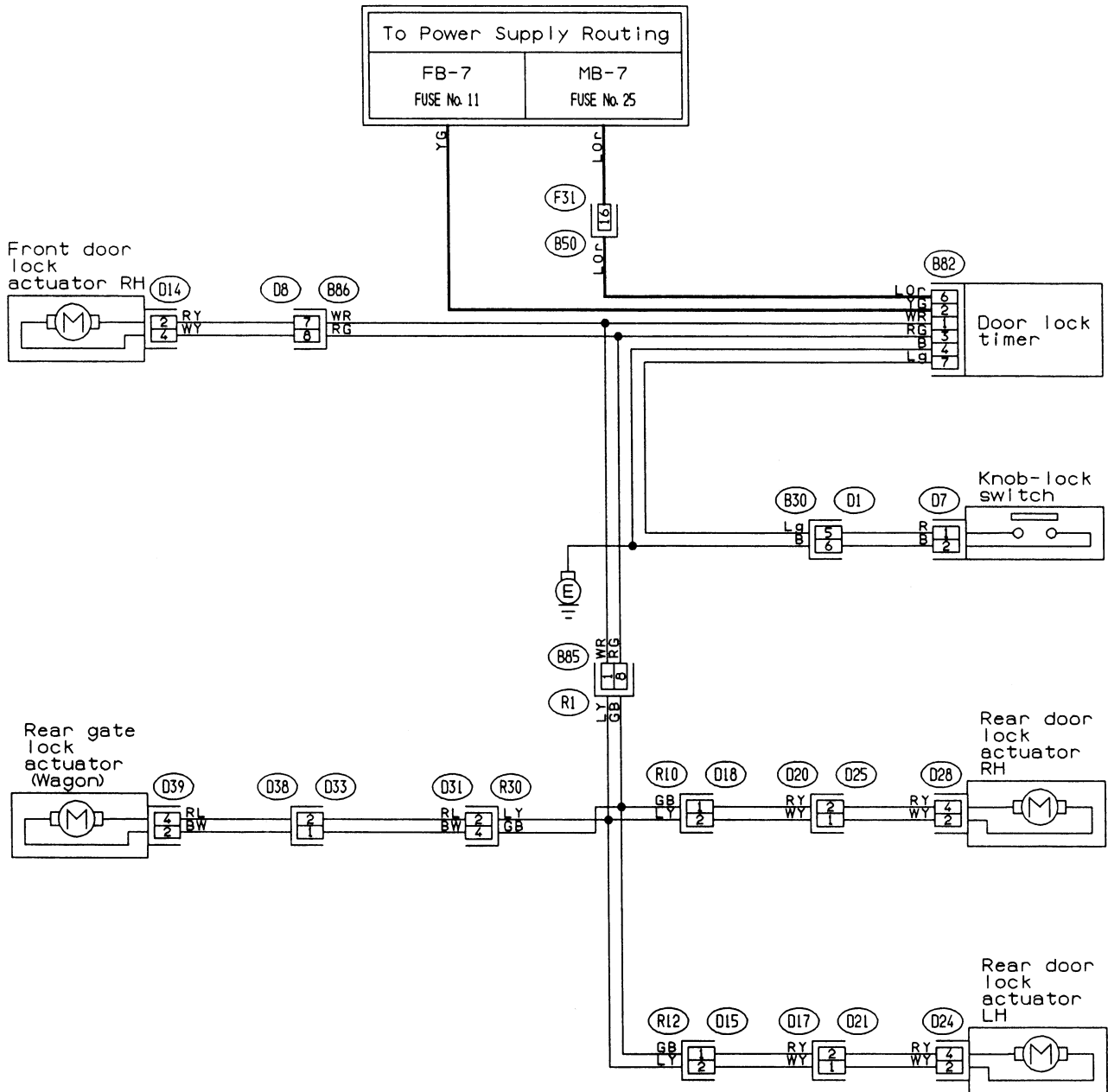

○07 (Gray)

○033

□1 2

○B82

□1 2 3 4
5 6 7 8

○018 (Pink)

○015 (Pink)

□1 2

○031

□1 2
3 4

○01

○08

□1 2 3
4 5 6 7 8
9 10 11 12 13

○014 ○028

○024 ○039

□1 2
3 4

○F31

○B85 (Blue)

□1 2 3 4 □ 5 6 7
8 9 10 11 12 13 14 15 16

13. ENGINE ELECTRICAL SYSTEM

● 1800 cc engine model

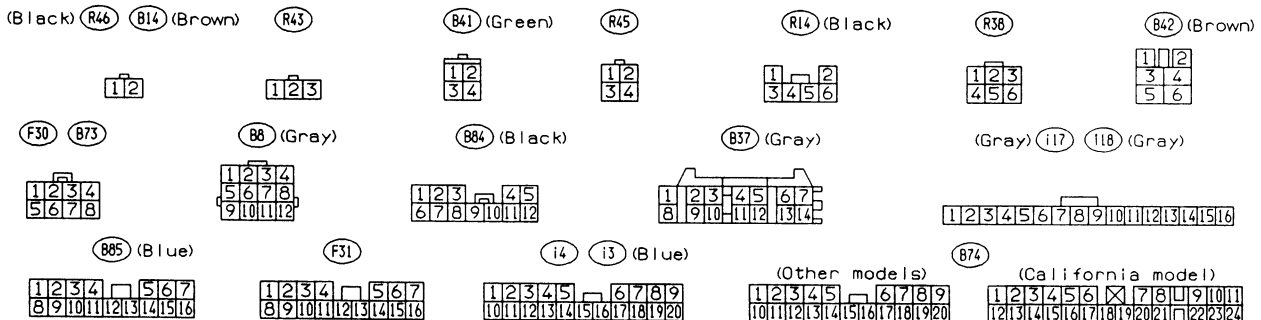
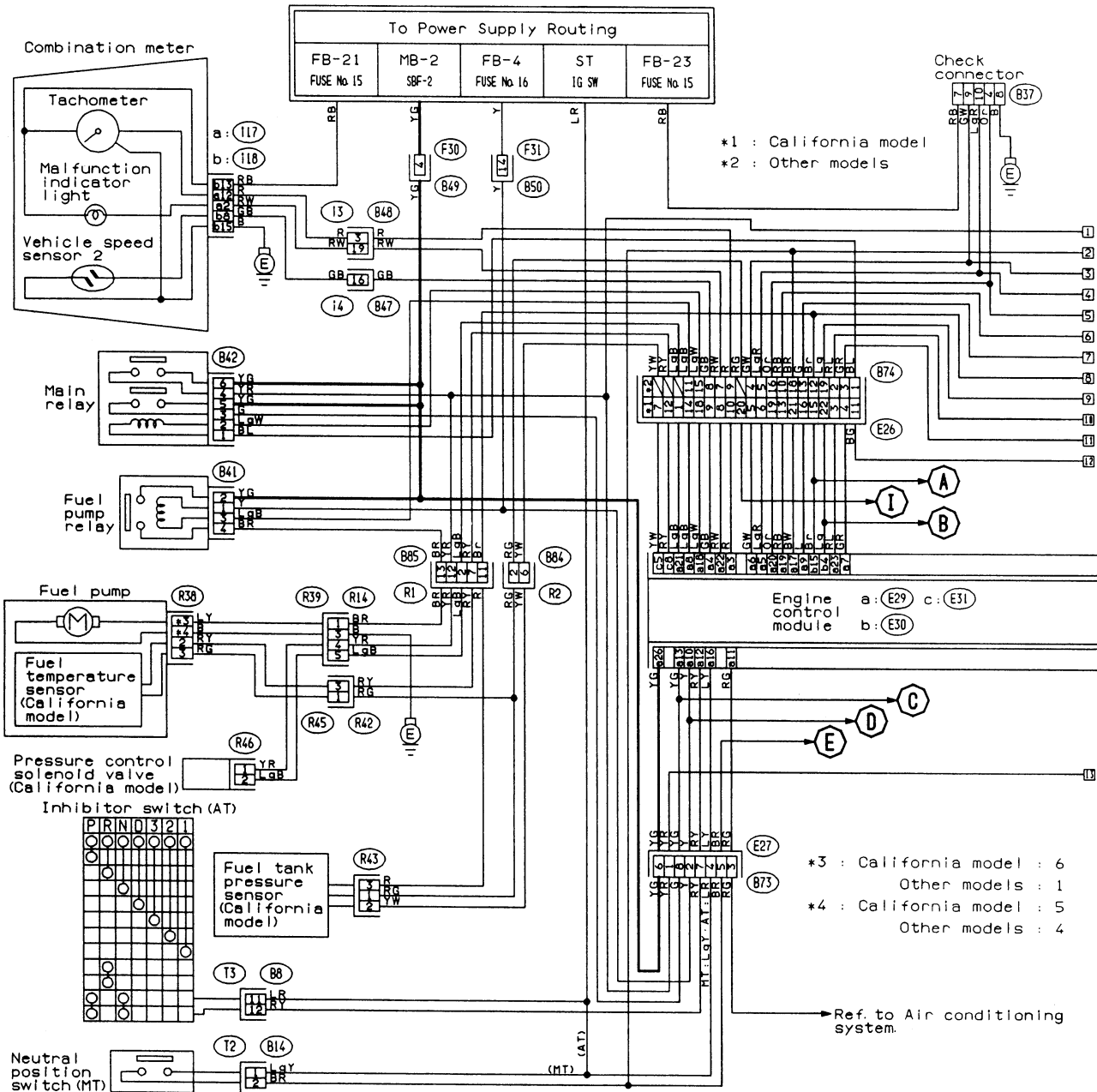

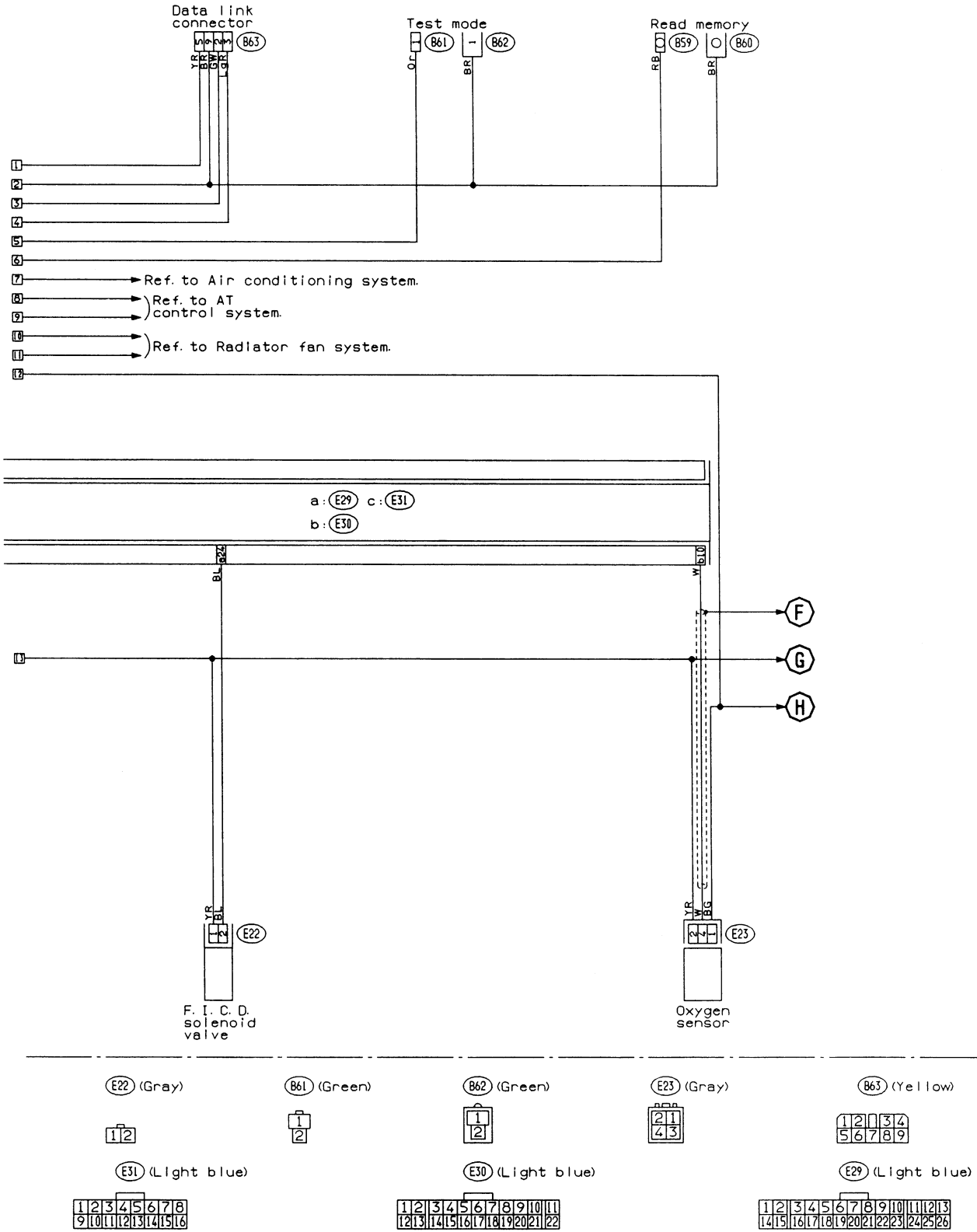

5. Wiring Diagram

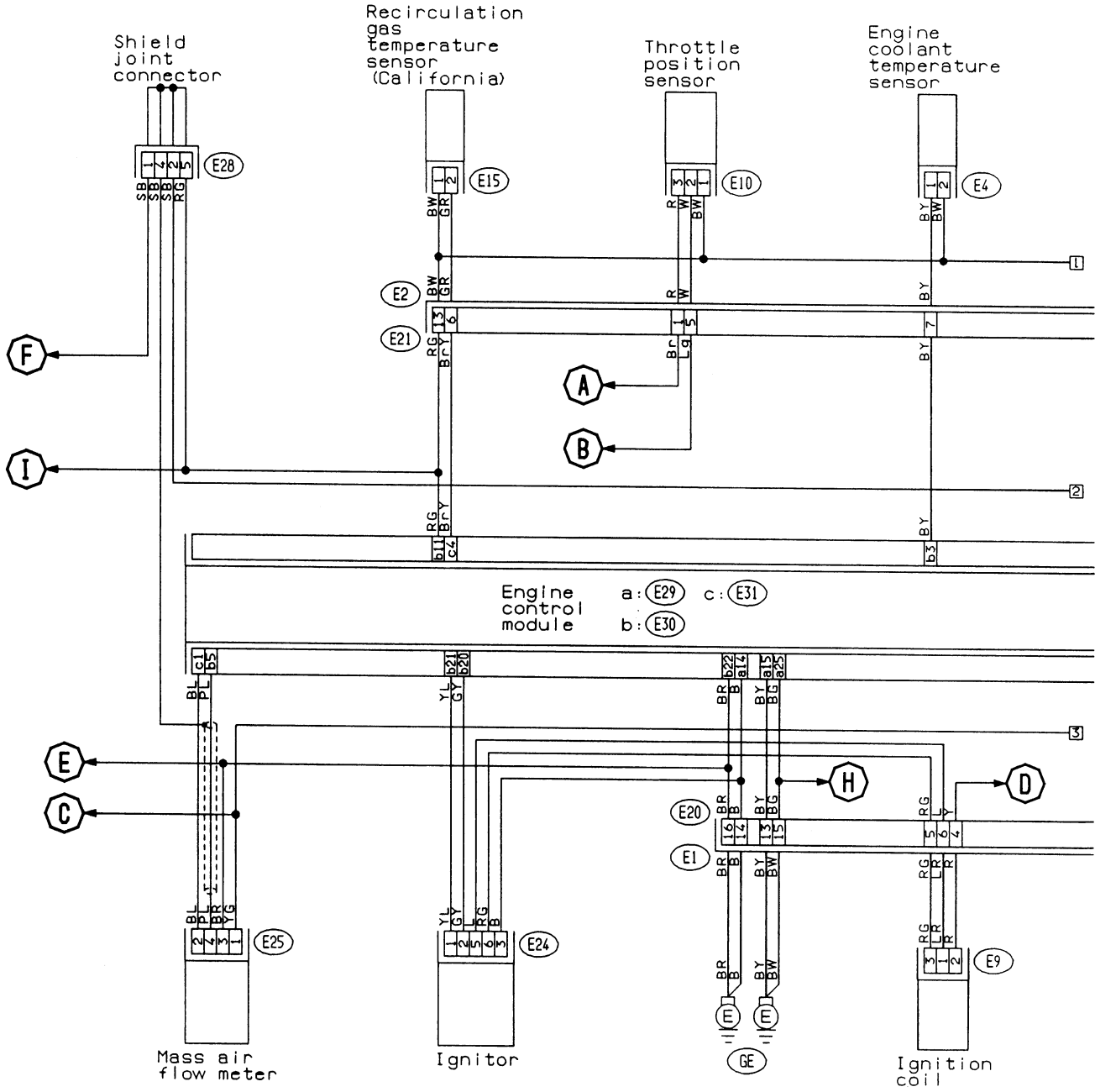

- (E15) (Black) (E4) (Brown) (E10) (Gray) (E9) (Gray) (E25) (Gray) (E28)
- 1 2 1 2 1 2 3 1 2 3 1 2 3 4 5 1 2 3
4 5 6
- (E21) (E20) (Gray) (E31) (Light blue) (E30) (Light blue) (E29) (Light blue)
- 1 2 3 4 1 2 3 4 5 6 7 8 1 2 3 4 5 6 7 8 9 10 11 1 2 3 4 5 6 7 8 9 10 11 12 13
5 6 7 8 9 10 11 12 13 14 15 16 12 13 14 15 16 17 18 19 20 21 22 14 15 16 17 18 19 20 21 22 23 24 25 26

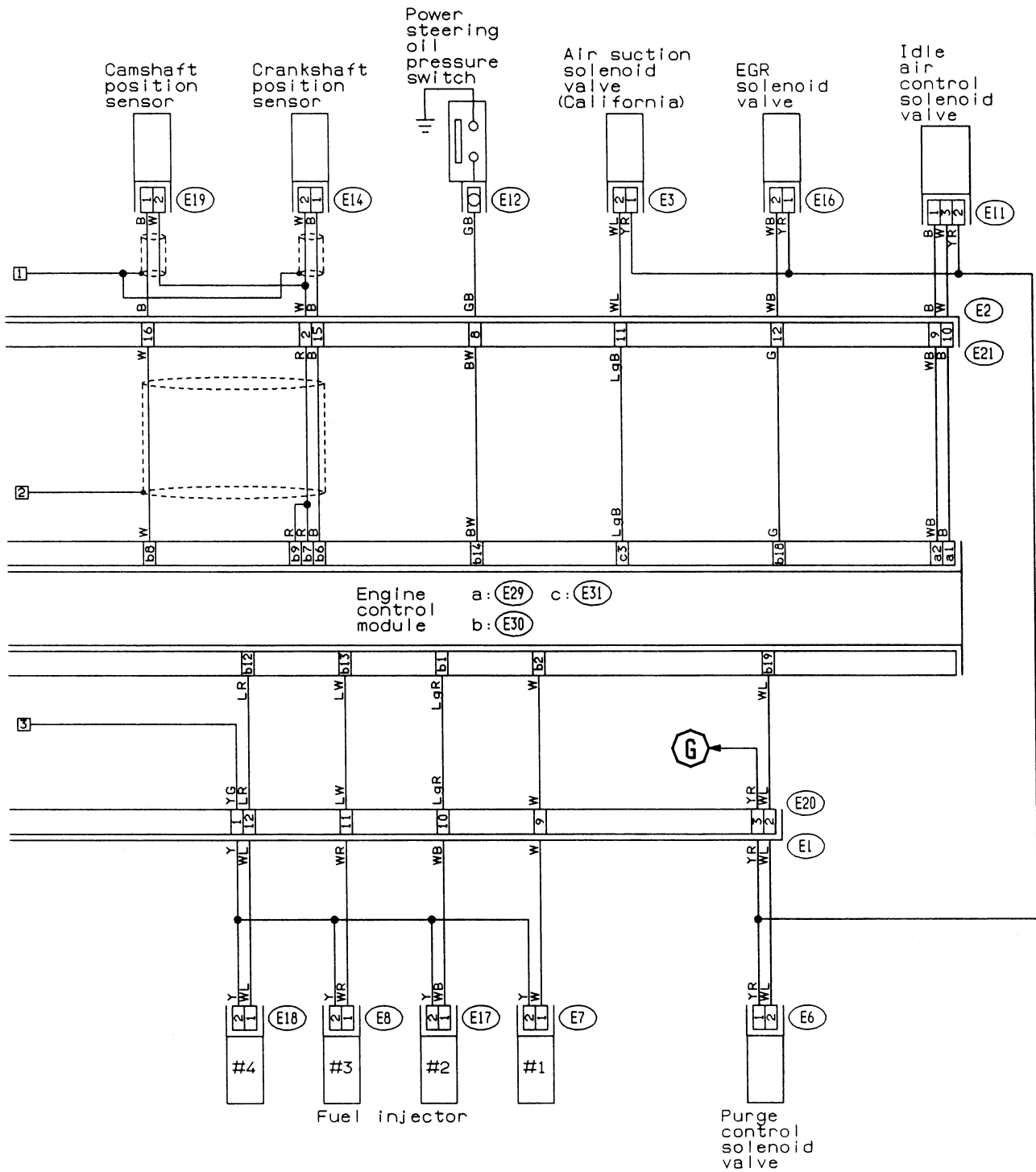

- | | | | |
|--------------|--------|---------------|--------------|
| (E19) (Gray) | (Gray) | (E7) (Gray) | (E17) (Gray) |
| (E14) (Gray) | (Gray) | (E8) (Gray) | (E18) (Gray) |
| | | (E16) (Brown) | (E3) (Gray) |
| | | (E6) (Blue) | (E11) (Gray) |
| (1 2) | (1 2) | (1 2) | (1 2 3) |

13. ENGINE ELECTRICAL SYSTEM

● 2200 cc engine model

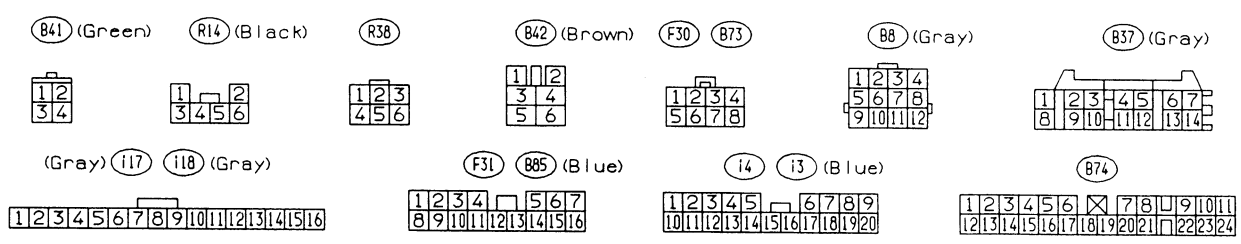
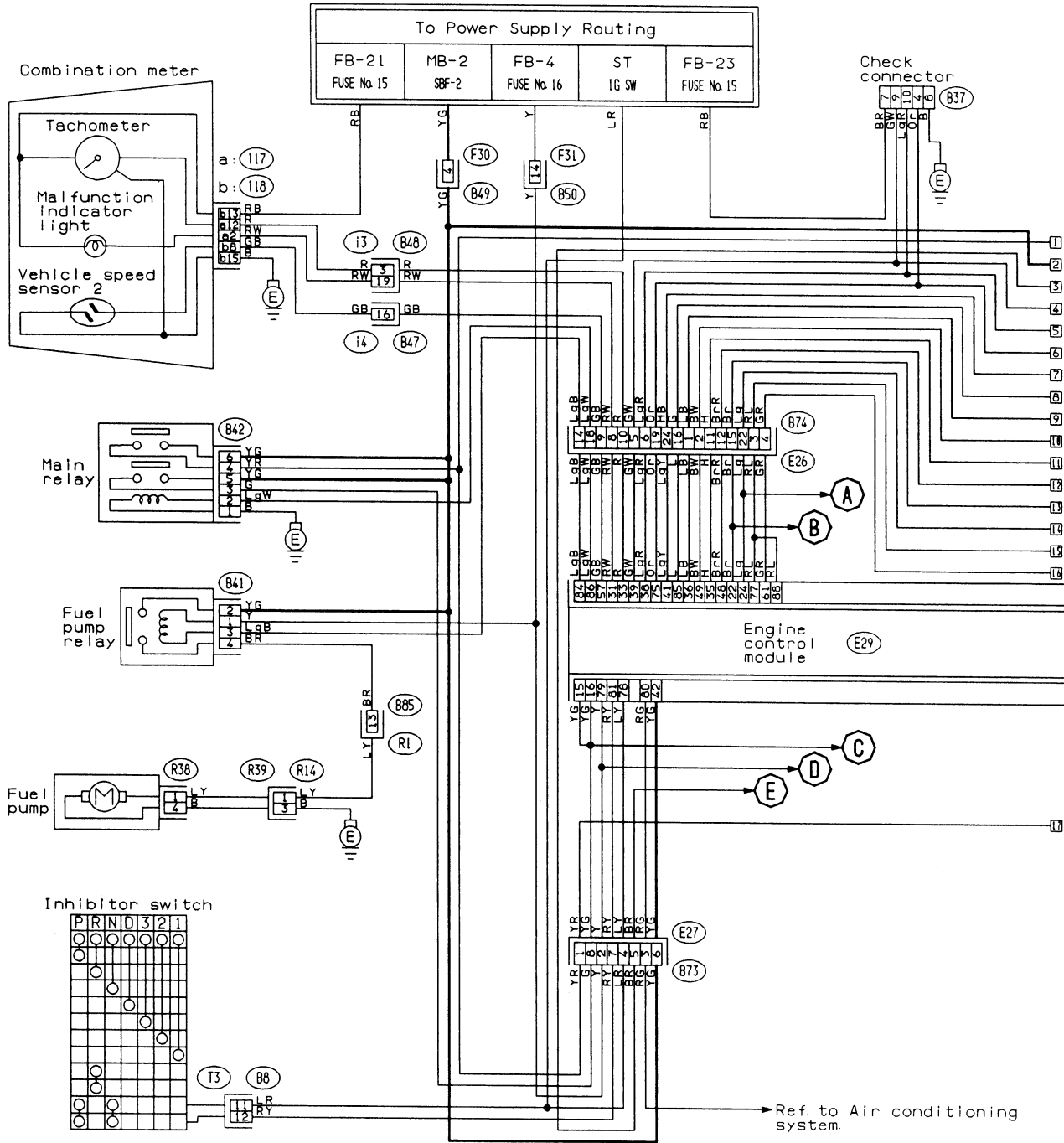

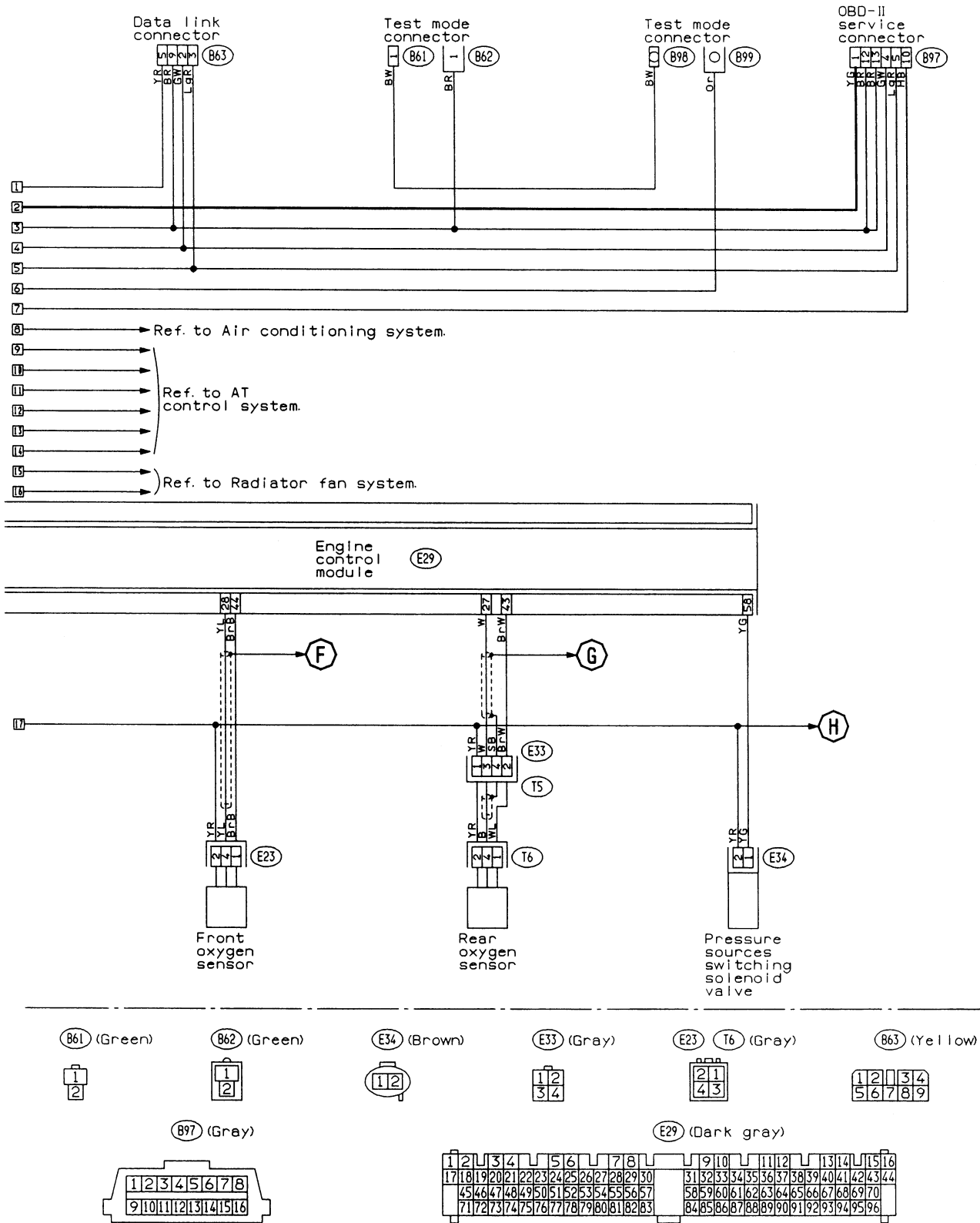

5. Wiring Diagram

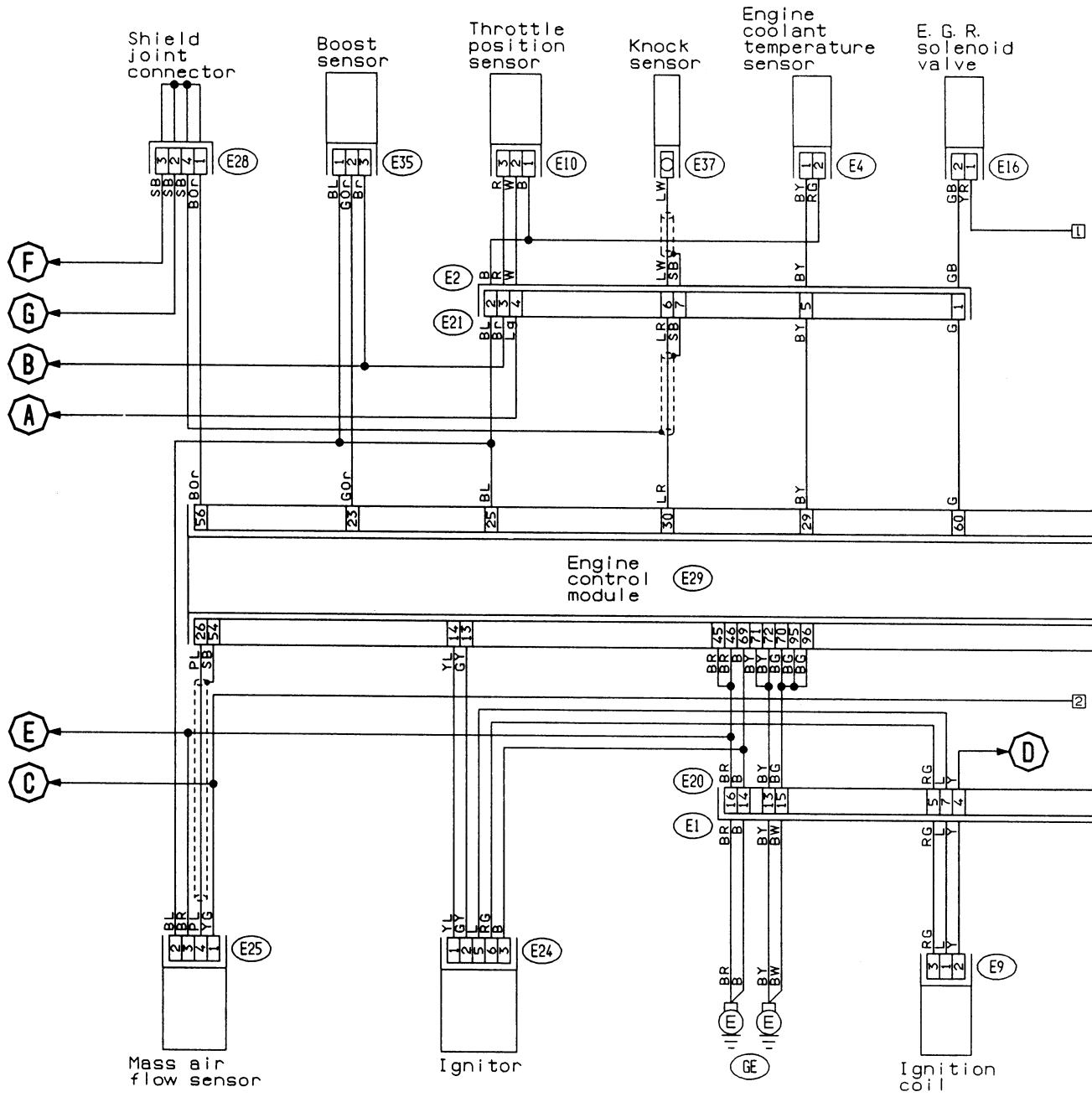

- (Brown) E4 E16 (Brown) (Brown) E10 E35 (Black) E9 (Gray) E25 (Gray)
- 112 123 123 12345
- E24 (Gray) E28 E21 (Gray) E20 (Gray)
- 123456 123 456 1234 5678 9101112 13141516

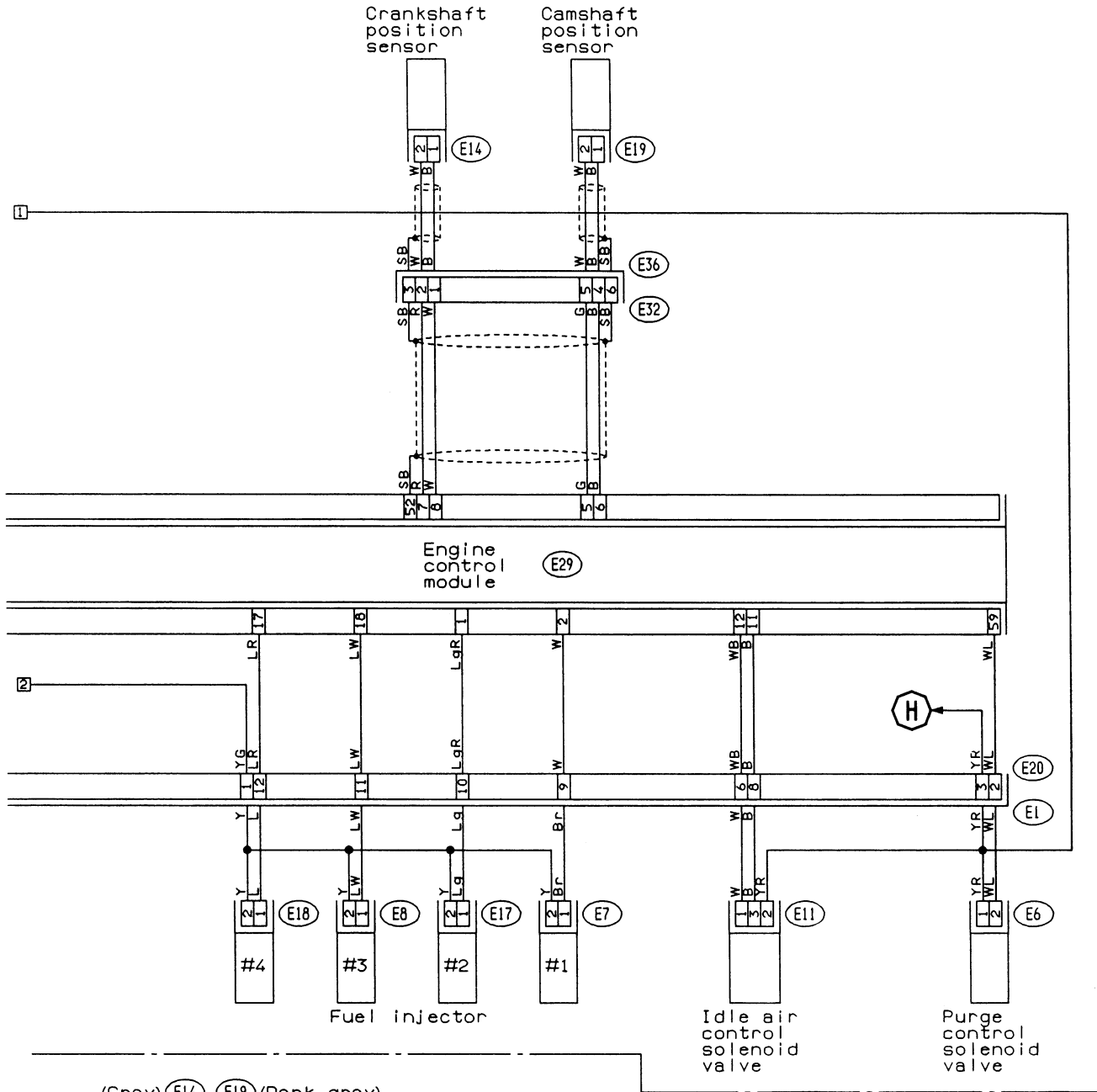

- (Gray) (E14) (E19) (Dark gray)
- (Light gray) (E7) (E17) (Light gray)
- (Dark gray) (E8) (E18) (Dark gray)
- (E6) (Blue)
- (E11) (Gray)
- (E32)

(E29) (Dark gray)

1	2	3	4	5	6	7	8	9	10	11	12	13	14	15	16
17	18	19	20	21	22	23	24	25	26	27	28	29	30	31	32
33	34	35	36	37	38	39	40	41	42	43	44	45	46	47	48
49	50	51	52	53	54	55	56	57	58	59	60	61	62	63	64
65	66	67	68	69	70	71	72	73	74	75	76	77	78	79	80
81	82	83	84	85	86	87	88	89	90	91	92	93	94	95	96

14. FRONT WIPER AND WASHER SYSTEM

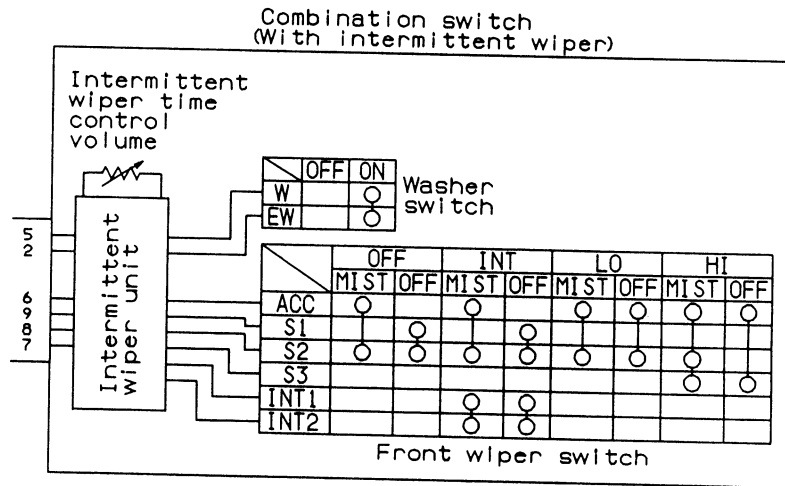
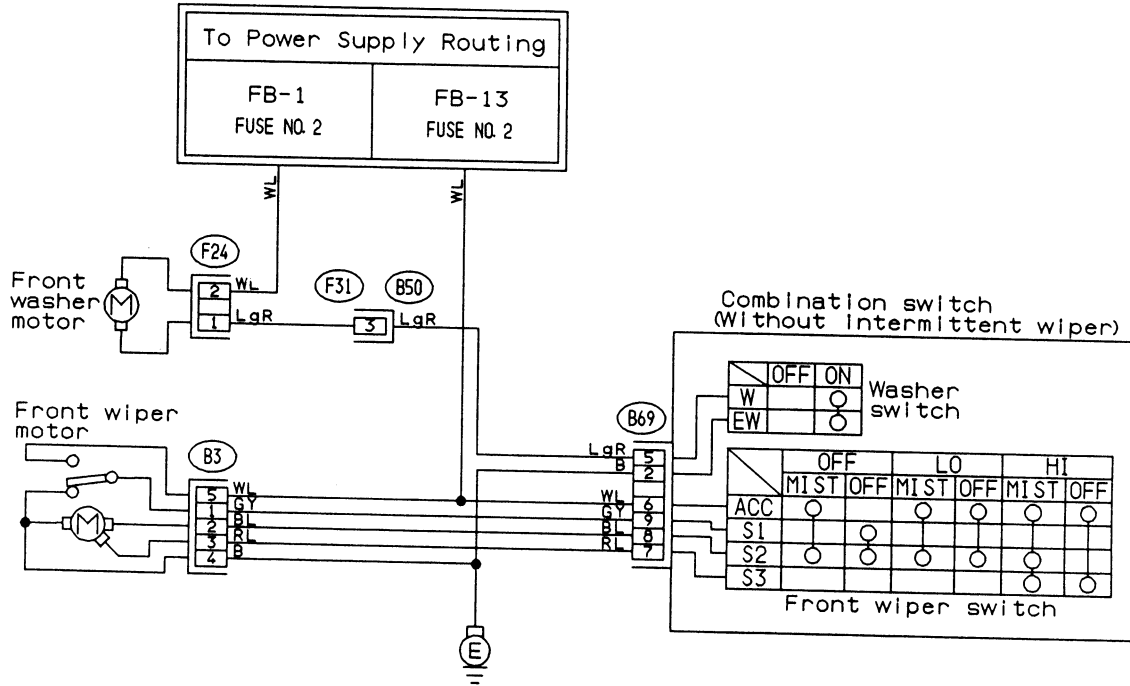

F24
(Green)

F31

B3

B69

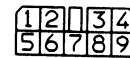
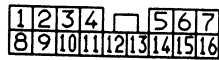

15. FUEL GAUGE SYSTEM

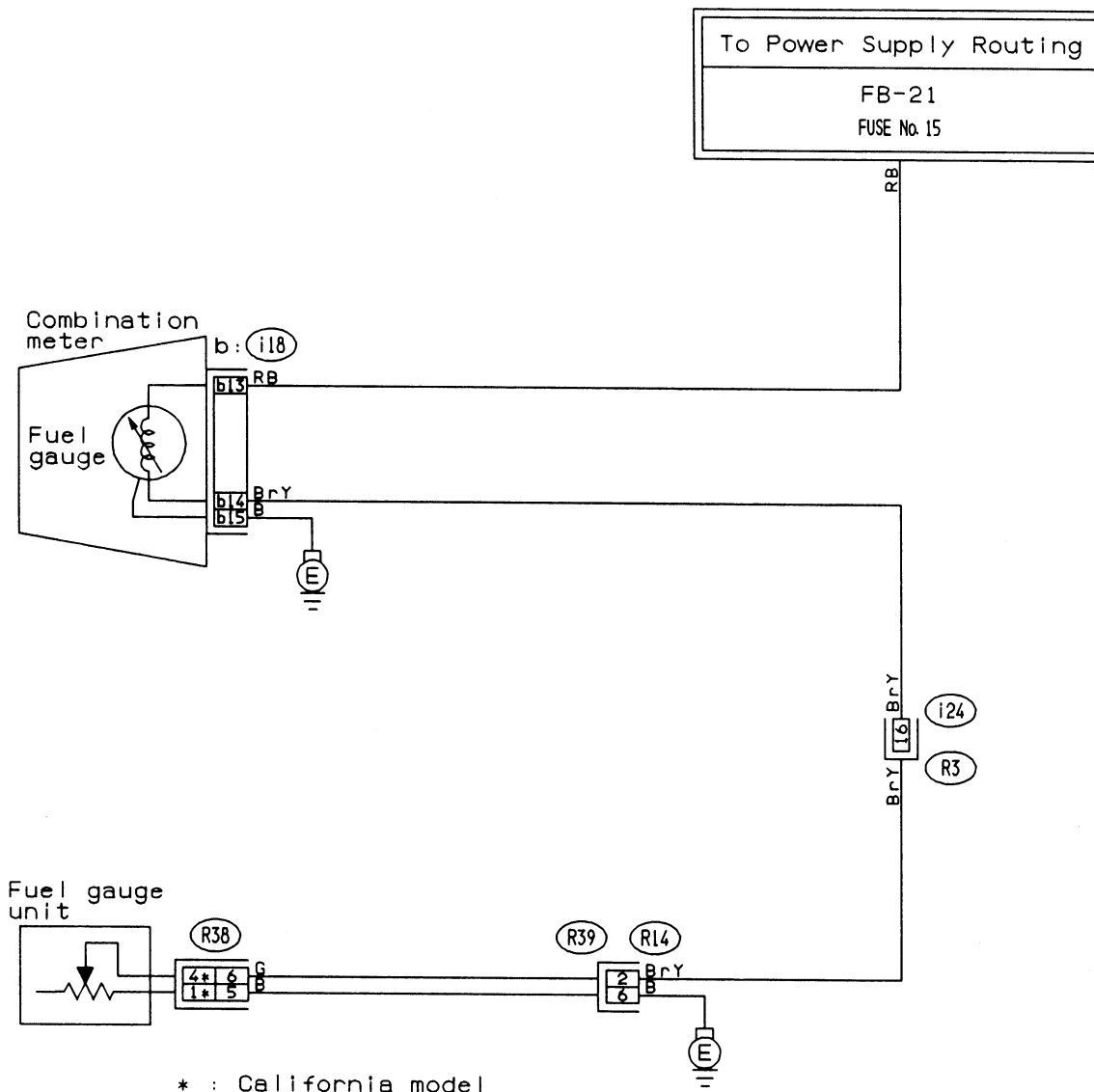

R14 (Black)

R38

i18 (Gray)

i24

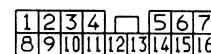
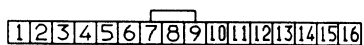

16. HORN AND CIGARETTE LIGHTER SYSTEM

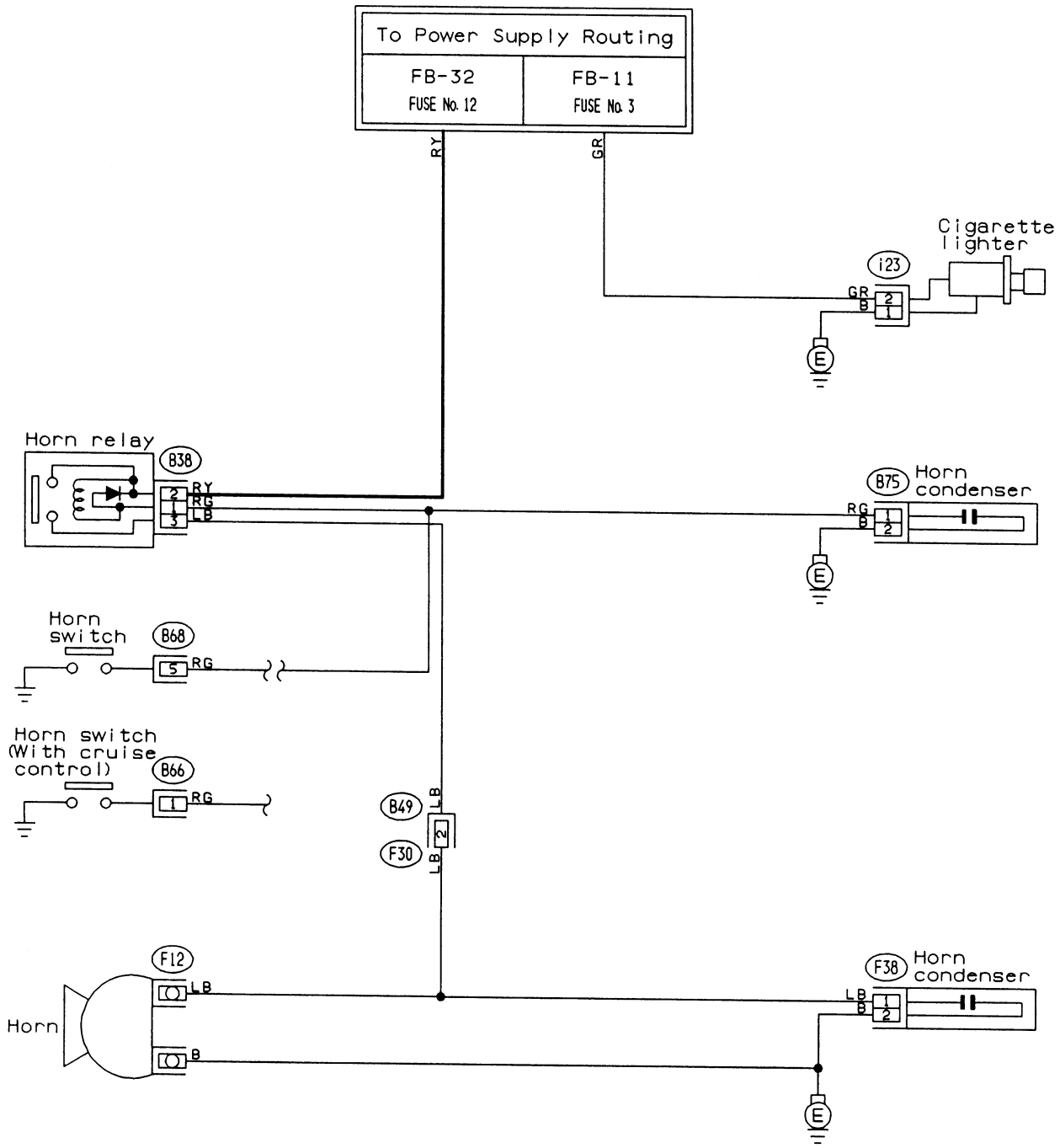

(F38) (Black)

(i23)

(B75) (Black)

(B38) (Black)

(B66) (Black)

(F30)

(B68)

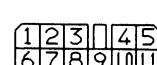

17. LIGHTING (HEADLIGHT) SYSTEM

• U.S.A. model

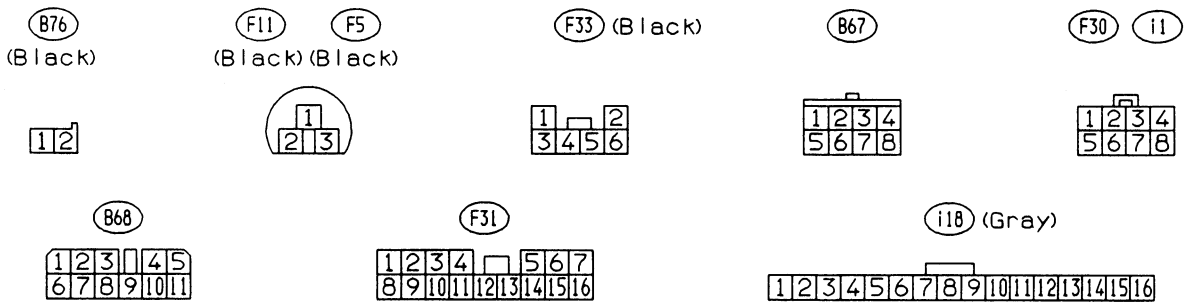
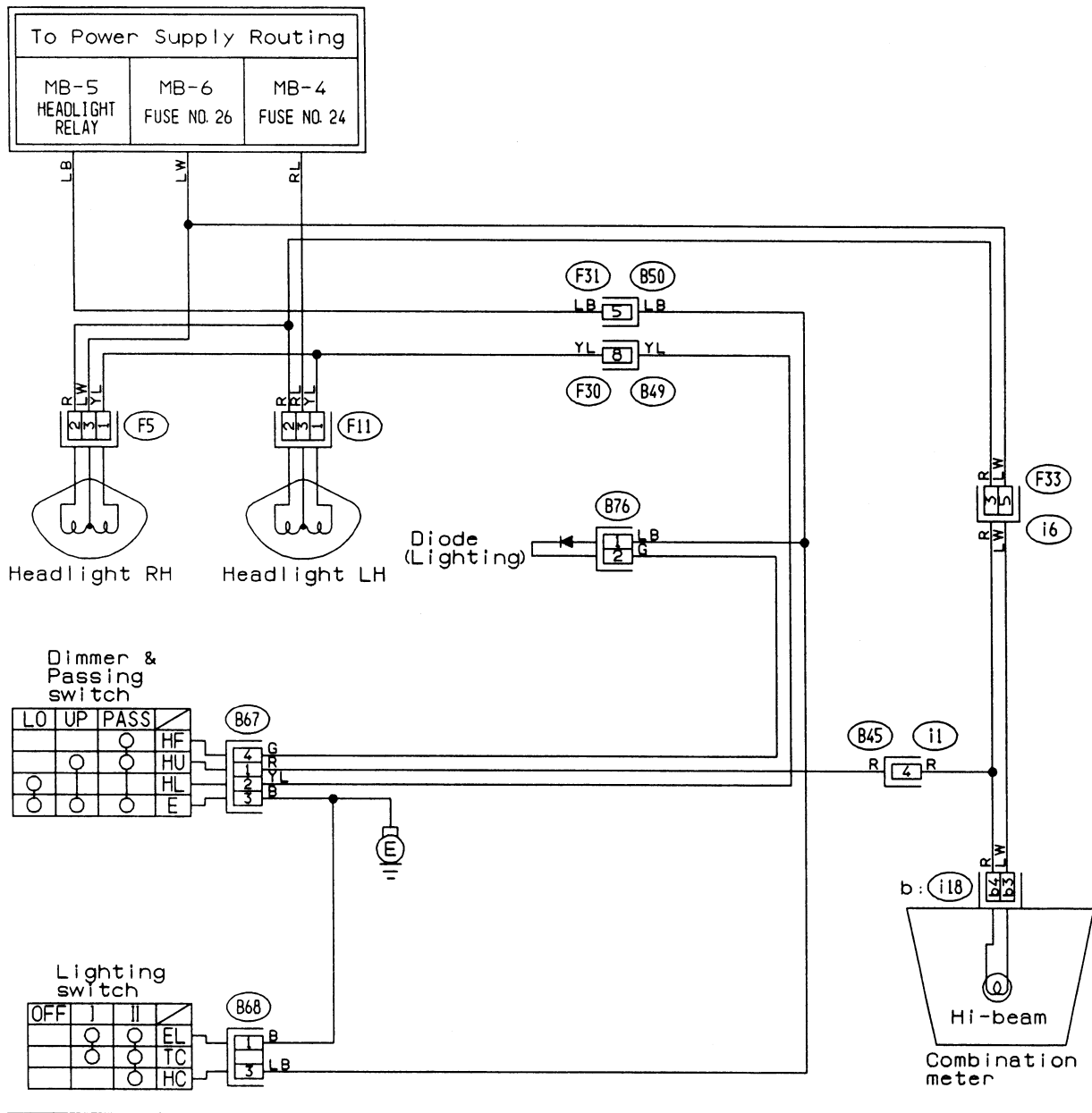

17. LIGHTING (HEADLIGHT) SYSTEM

● Canada model

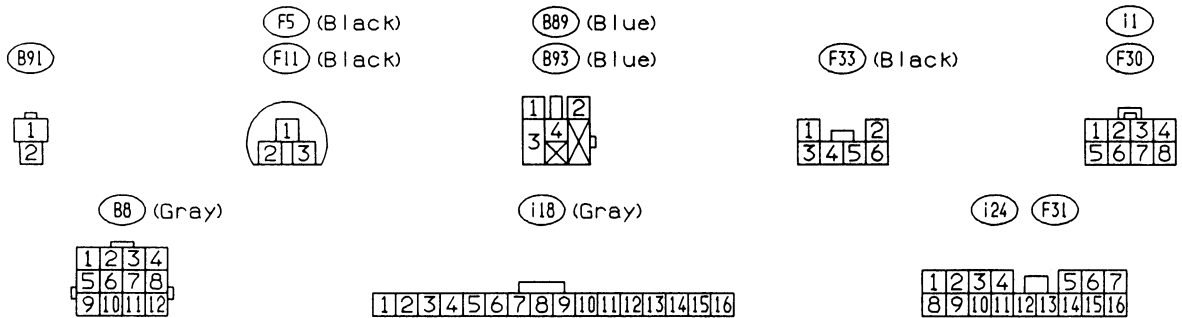
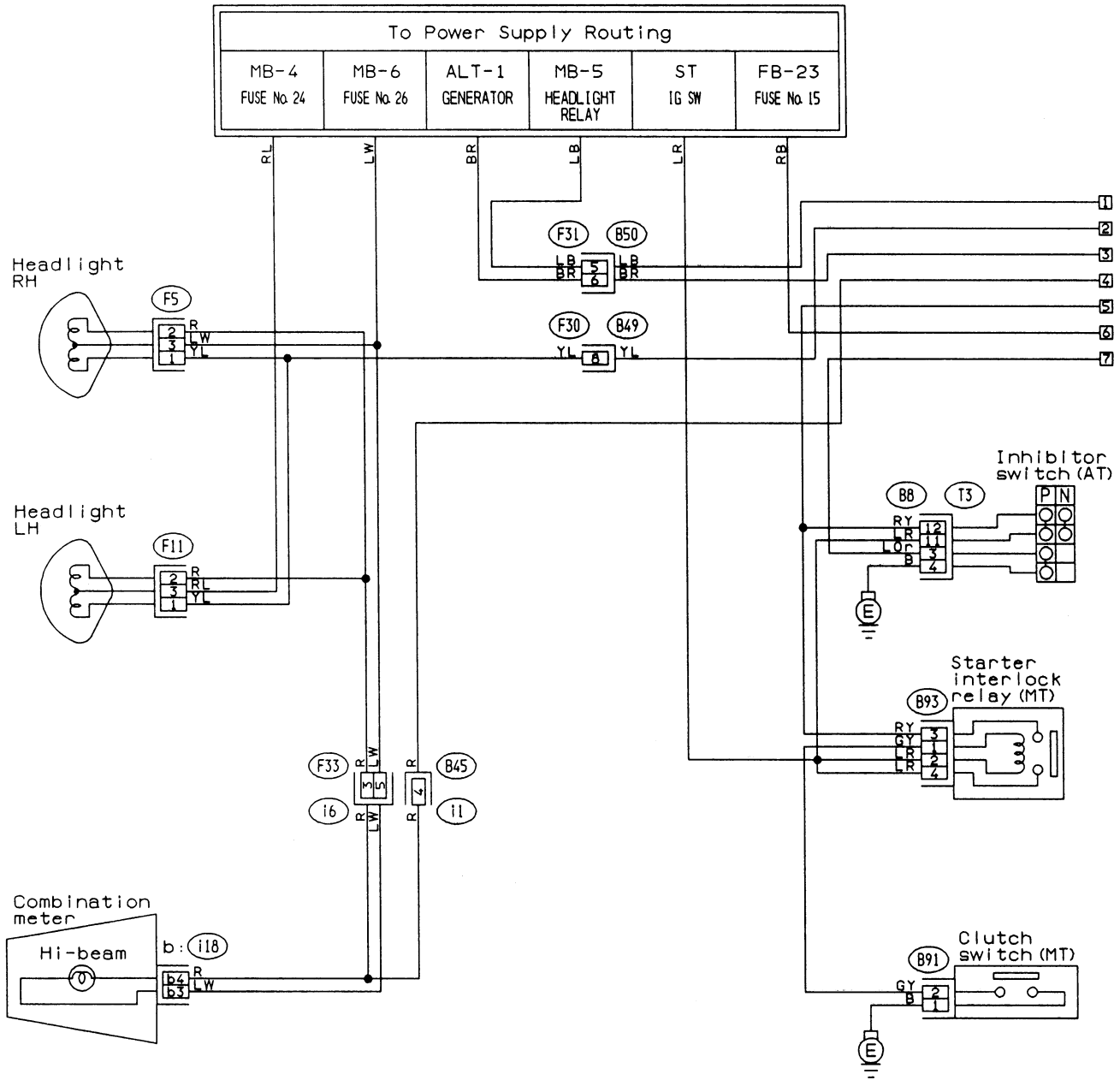

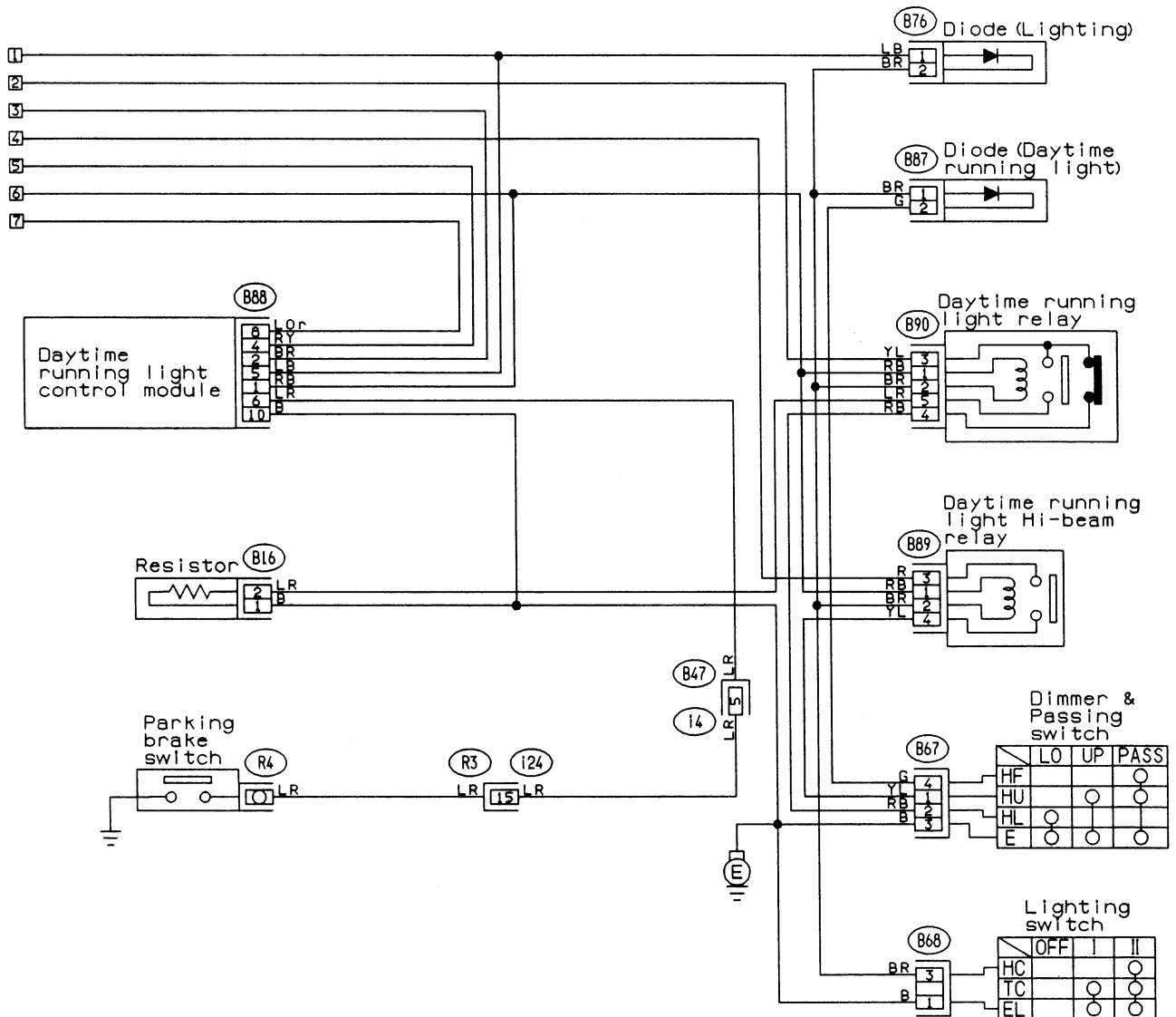

(B76) (Black)

(B87) (Black)

(B16) (Gray)

(B90) (Black)

(B67)

(B88)

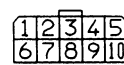

(B68)

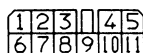

(i4)

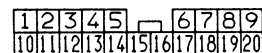

18. LIGHTING
(TAIL LIGHT-ILLUMINATION LIGHT-etc.) SYSTEM

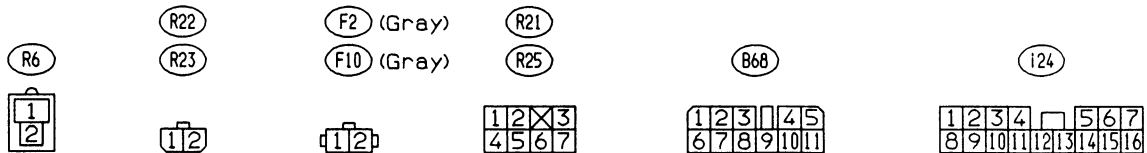
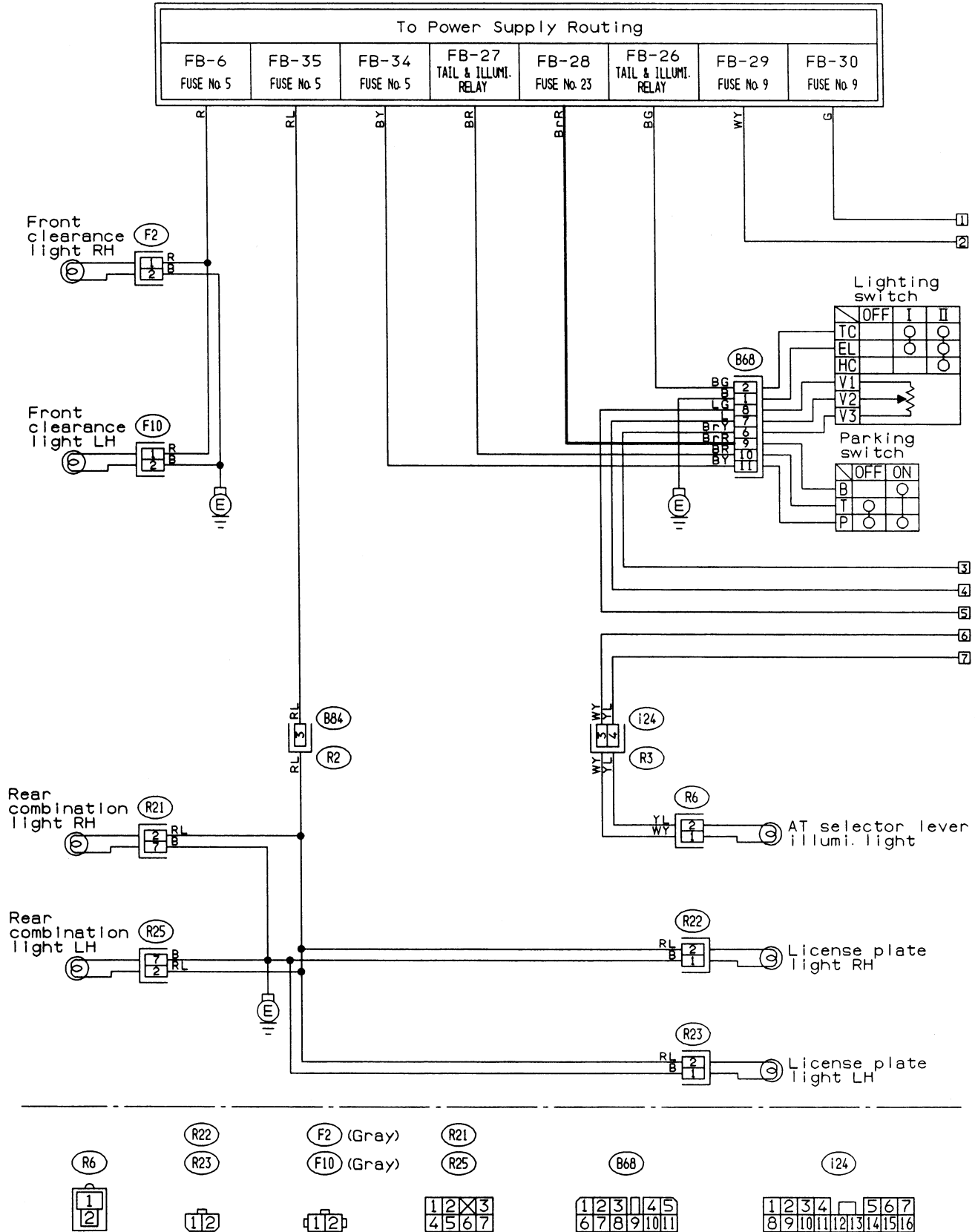

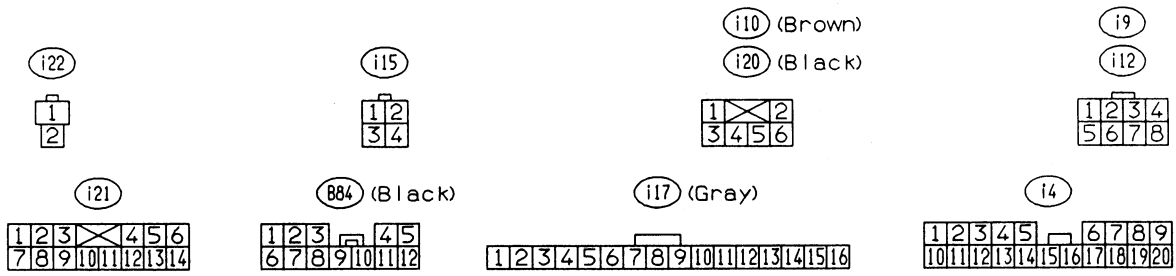
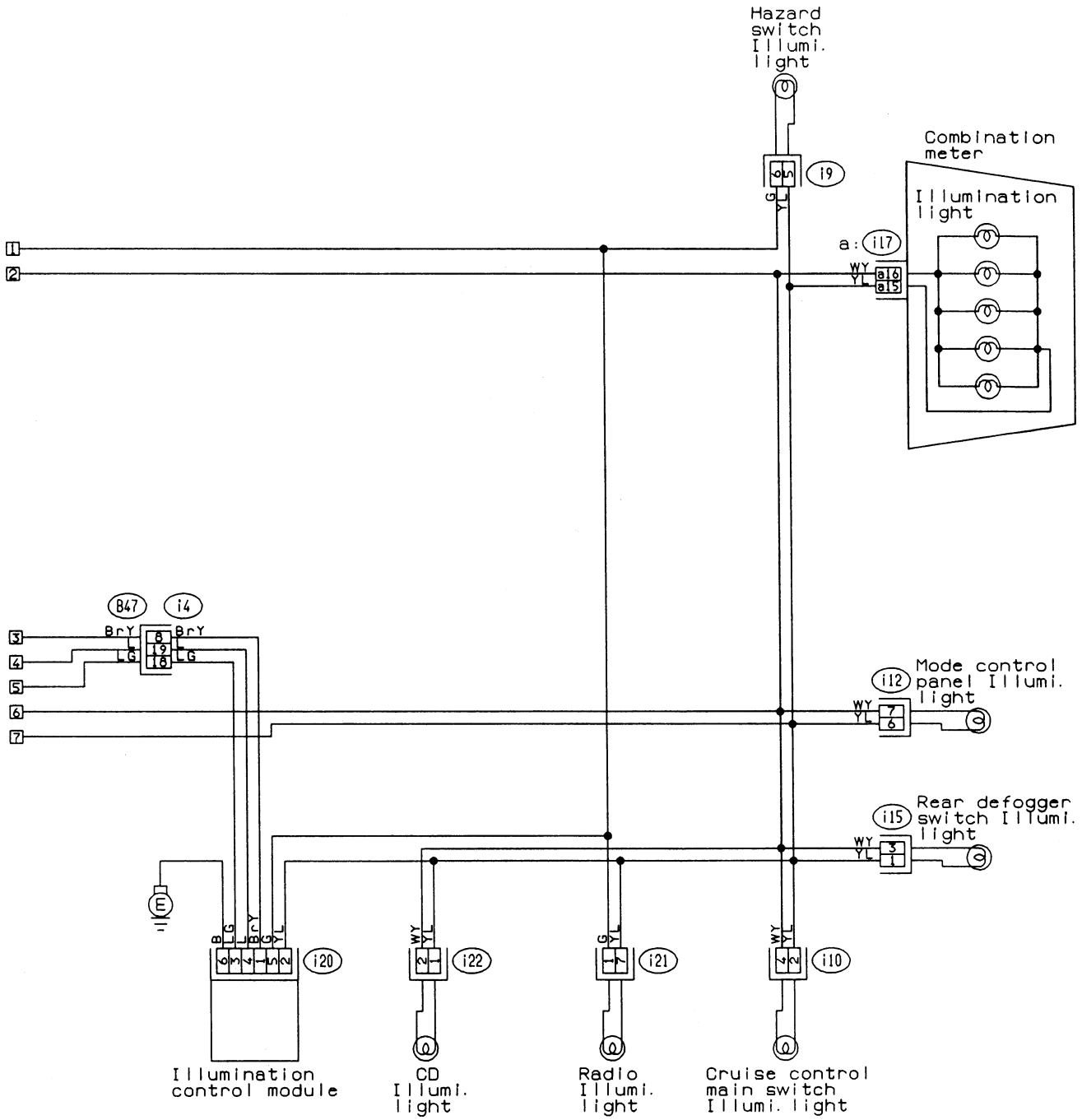

19. OIL PRESSURE AND TEMPERATURE GAUGE SYSTEM

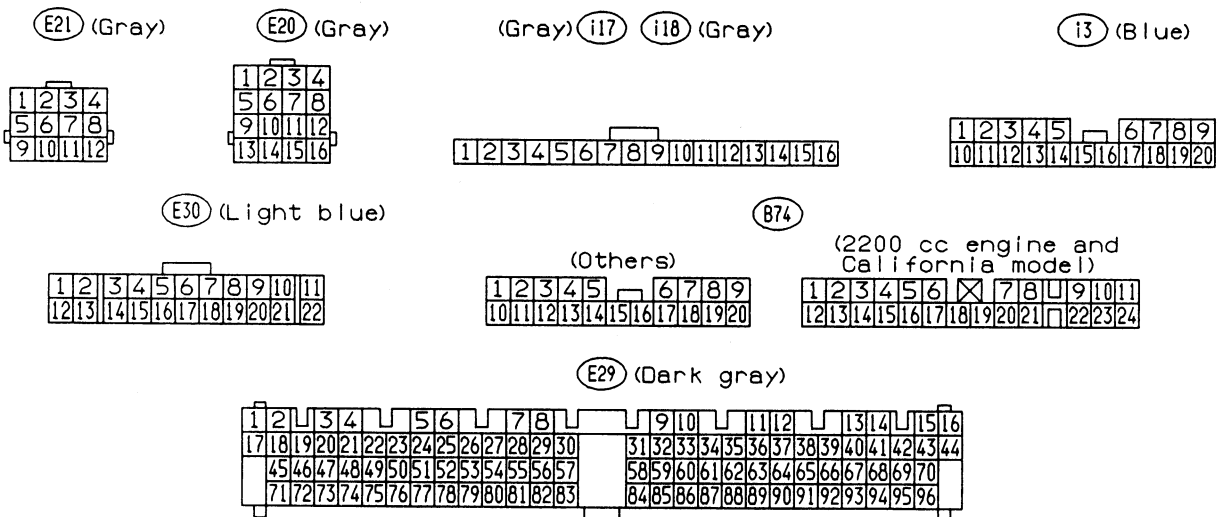
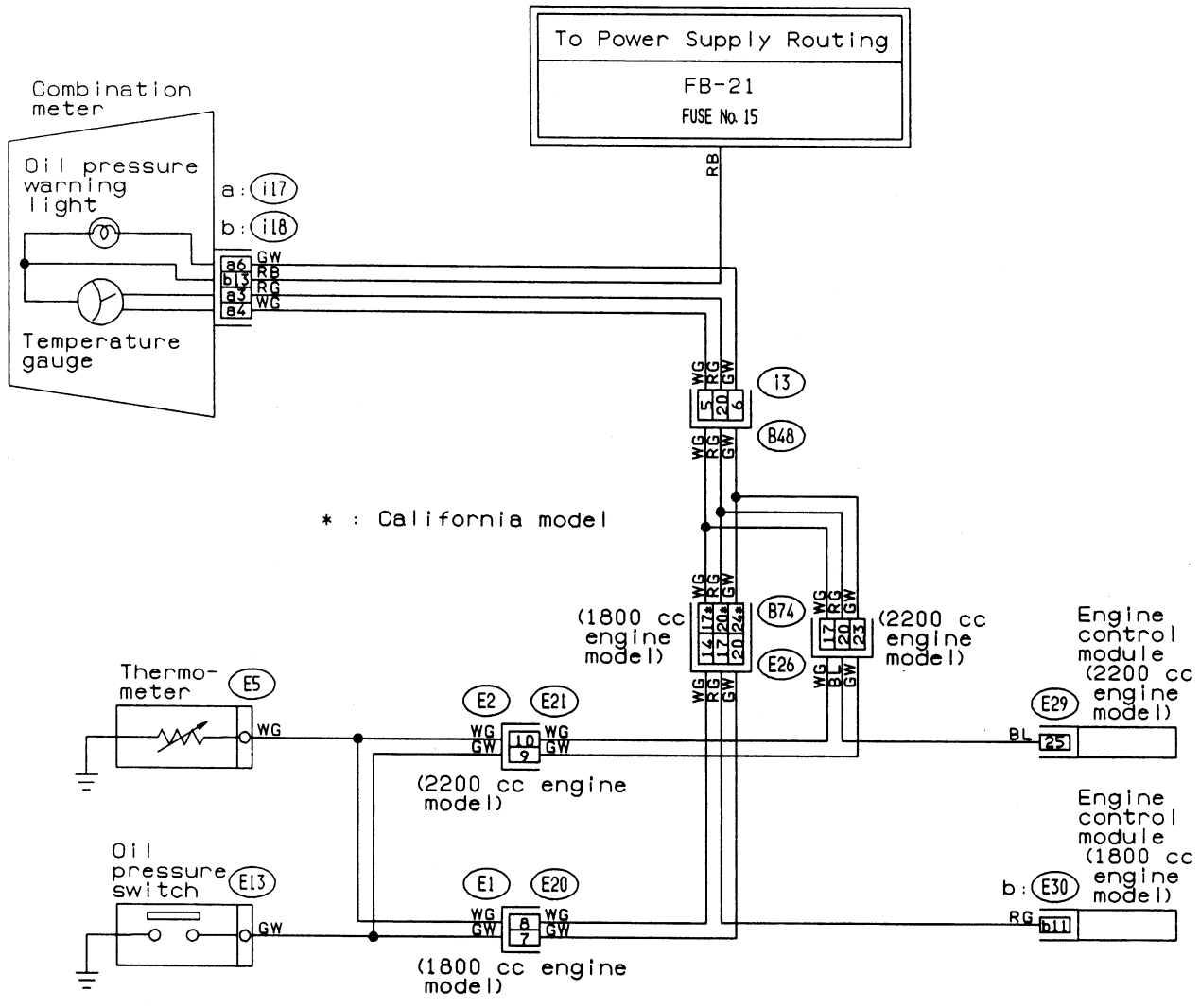

20. PARKING BRAKE AND BRAKE FLUID LEVEL WARNING SYSTEM

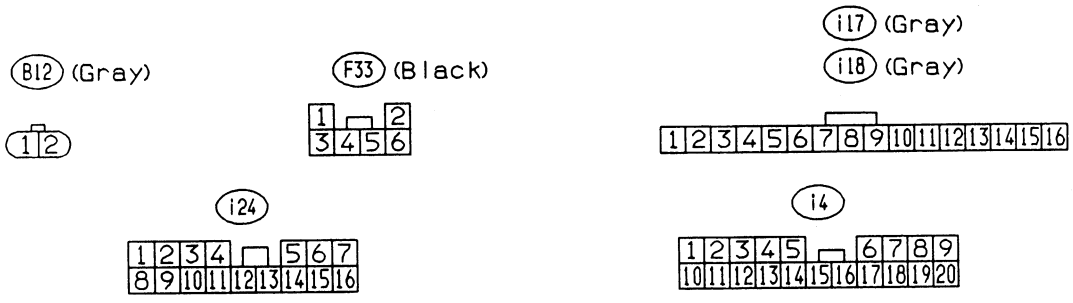
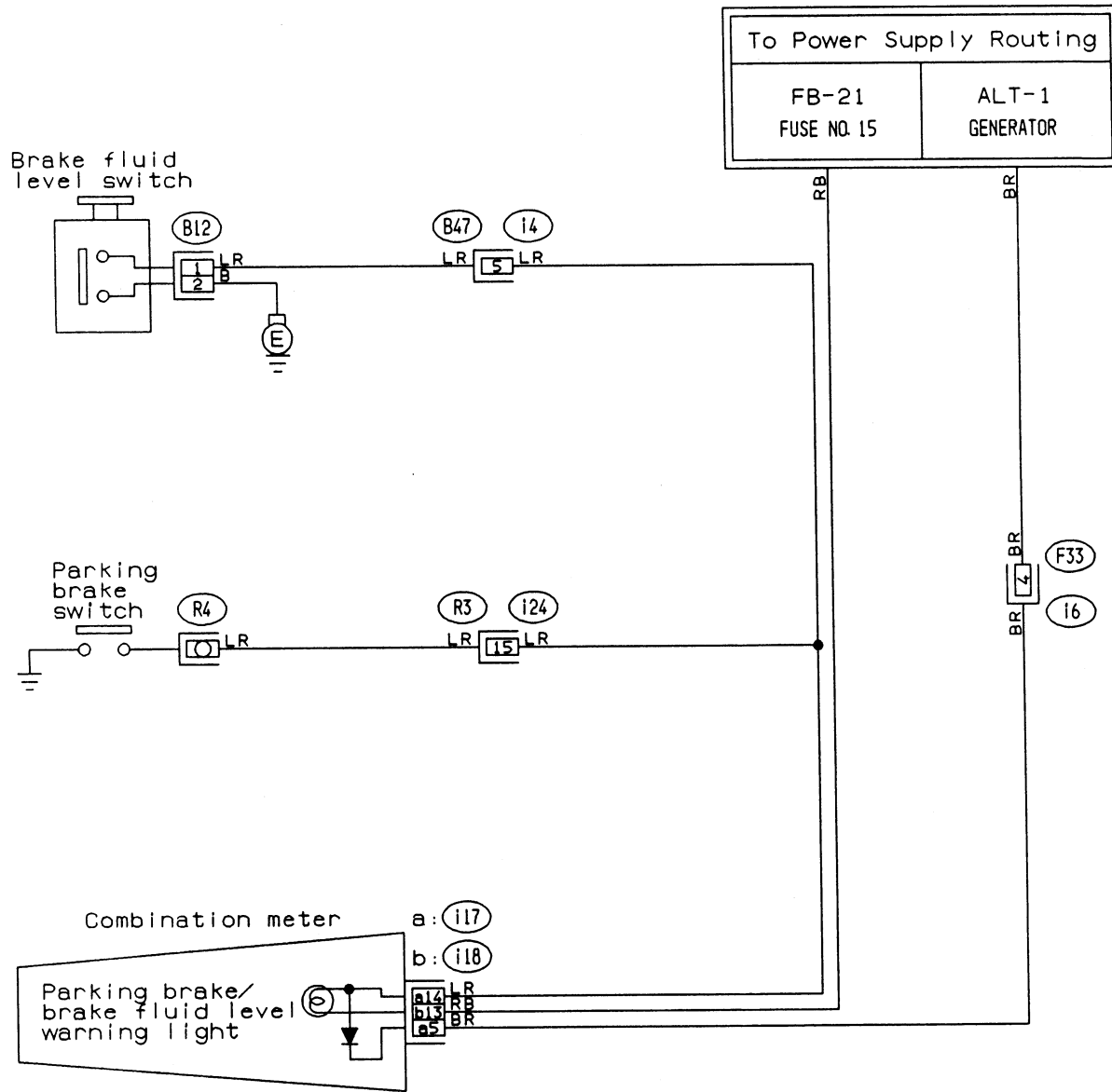

21. POWER WINDOW SYSTEM

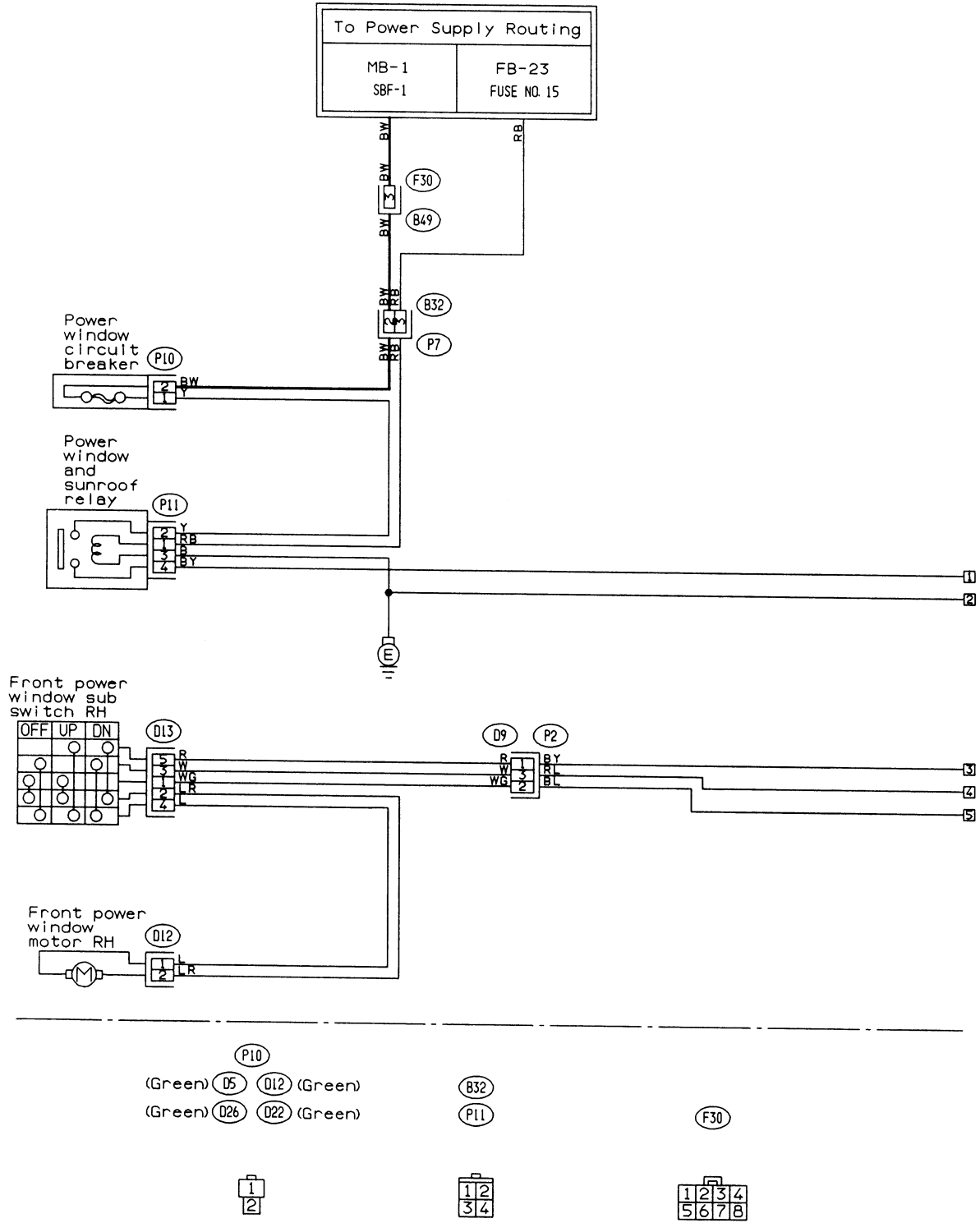

GU70-01A

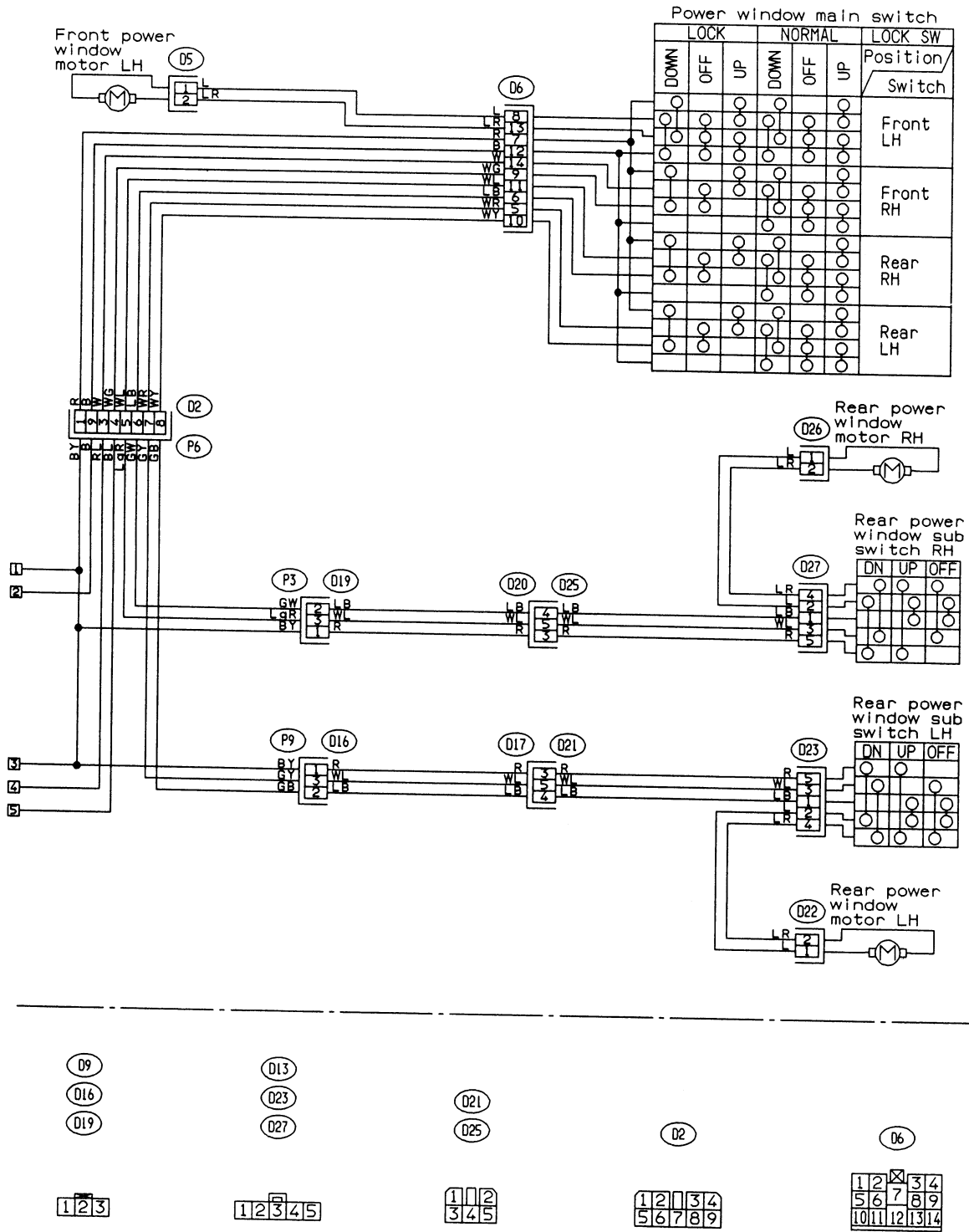

GU70-01B

22. RADIATOR FAN SYSTEM

● With A/C

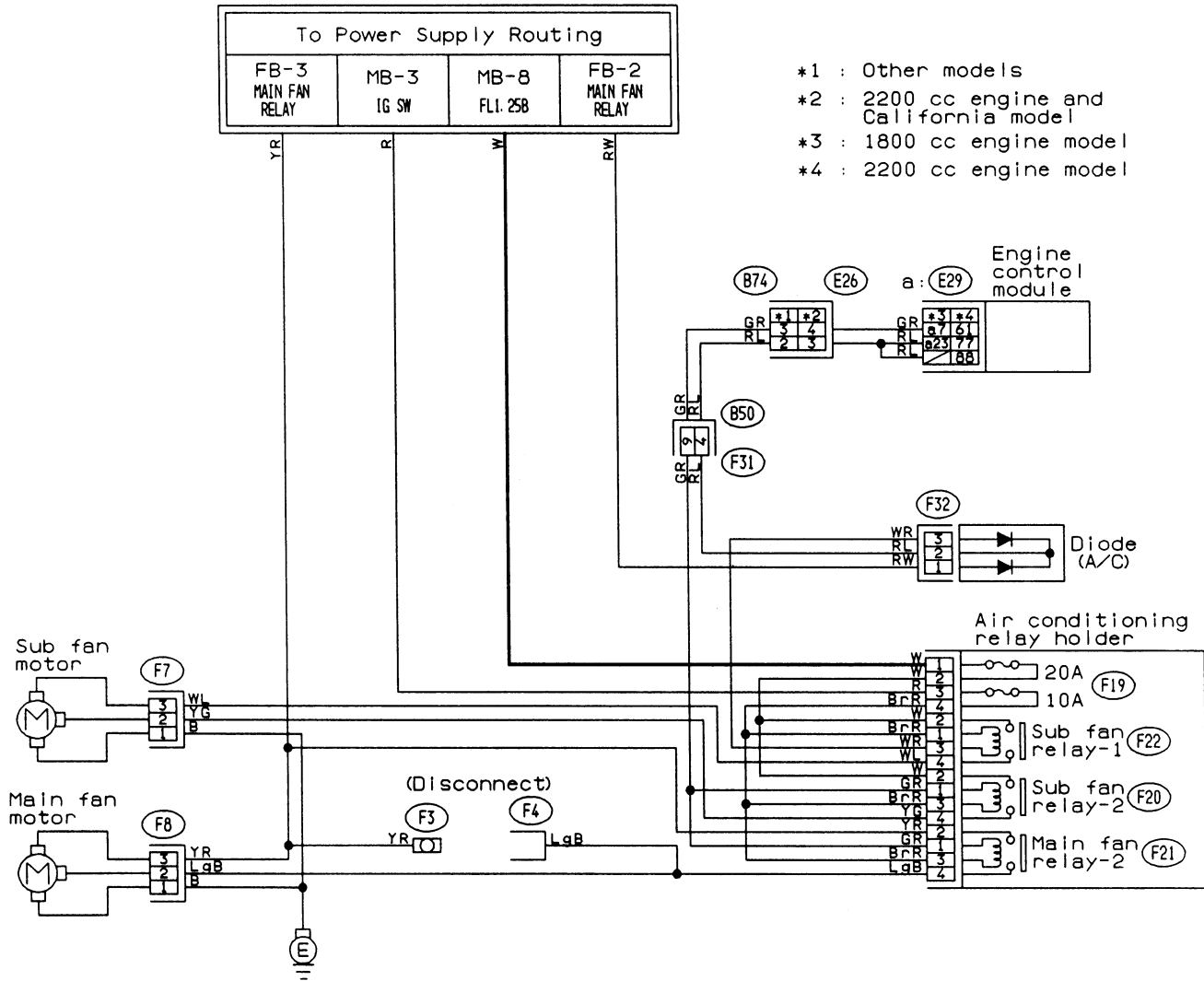

- *1 : Other models
- *2 : 2200 cc engine and California model
- *3 : 1800 cc engine model
- *4 : 2200 cc engine model

(F7) (Black)

(F8) (Black)

(F32) (Orange)

(F31)

(F19) (F20) (F21) (F22) (F23)

A/C relay holder (Black)

(B74)

(Other models)

(2200 cc engine and California model)

(E29)

(1800 cc engine model) (Light blue)

(2200 cc engine model) (Dark gray)

22. RADIATOR FAN SYSTEM

- Without A/C

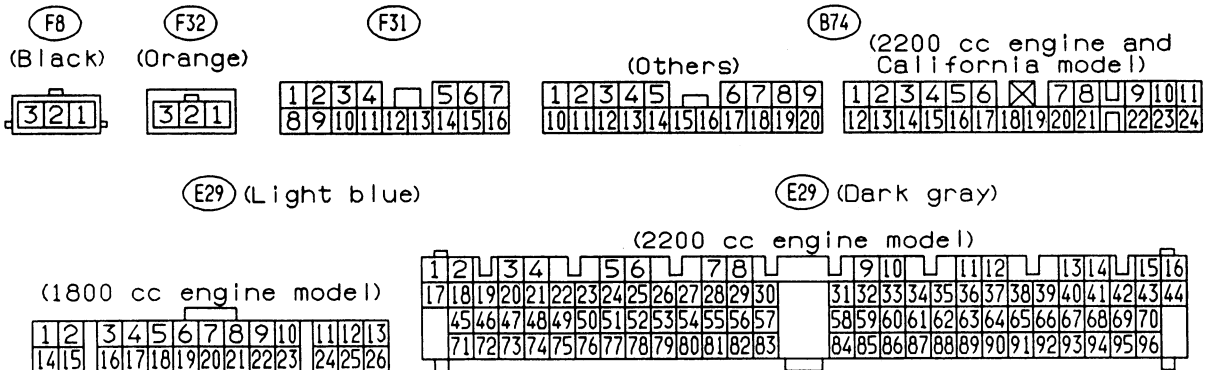
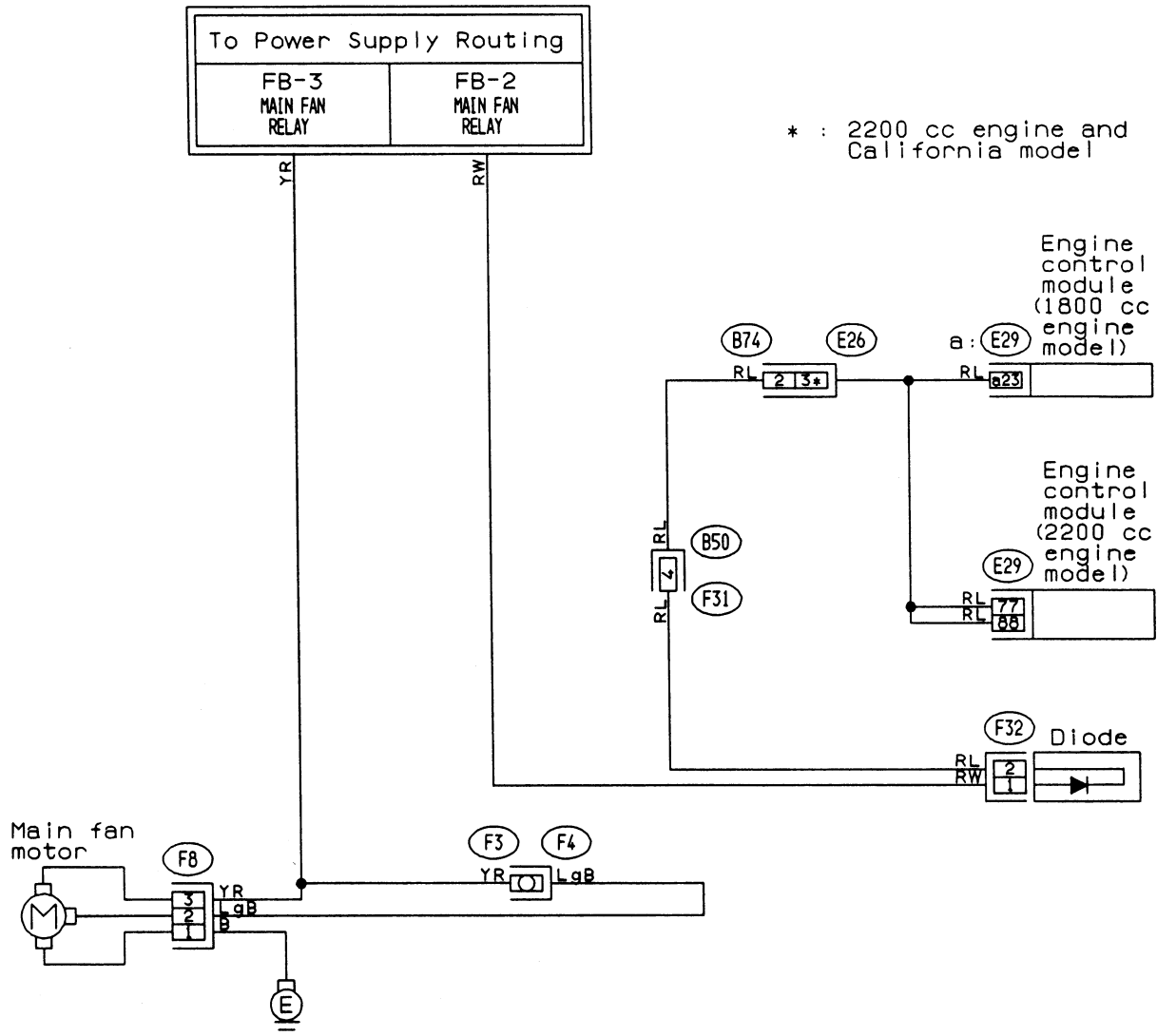

23. REAR WINDOW DEFOGGER SYSTEM

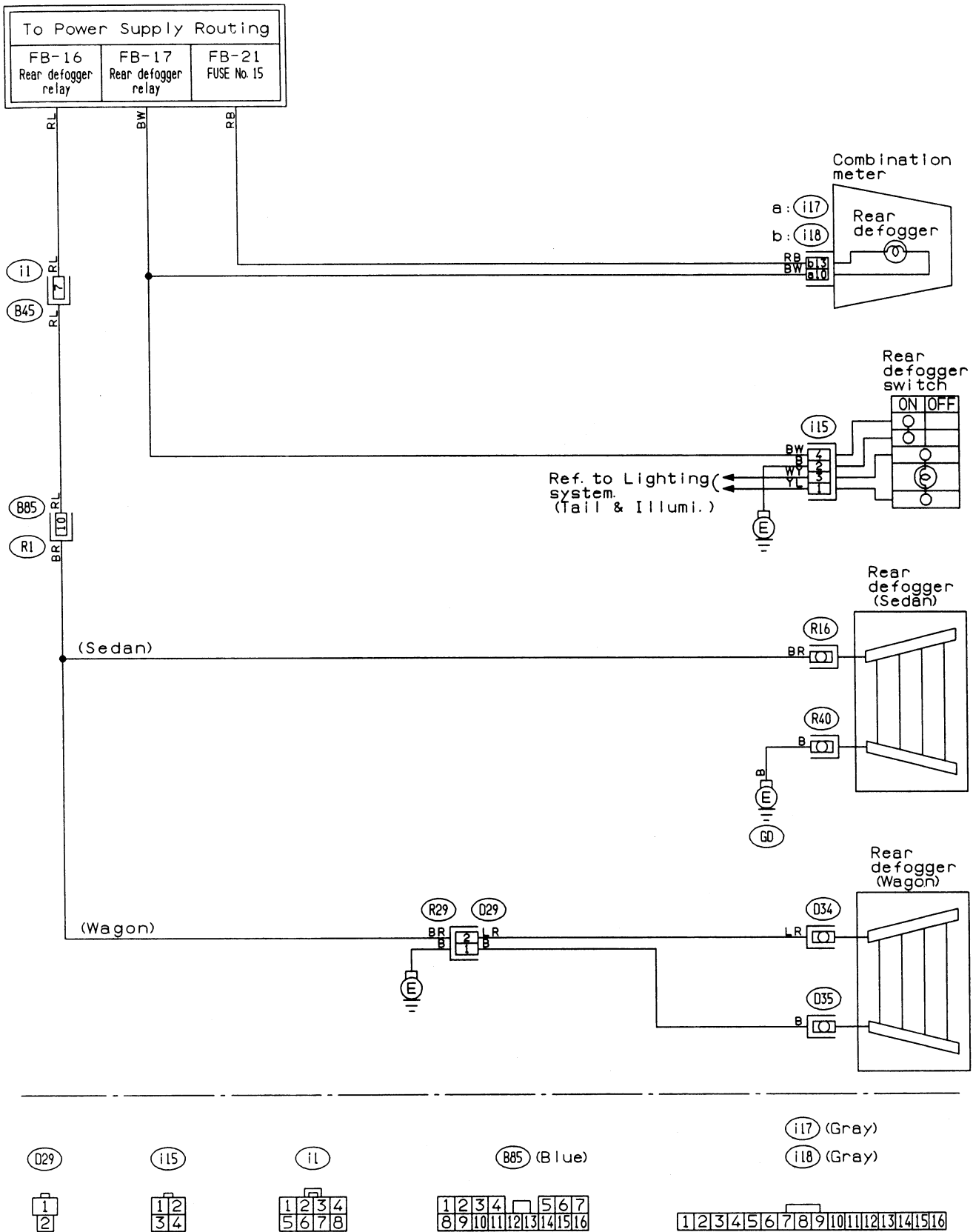

24. REAR WIPER AND WASHER SYSTEM

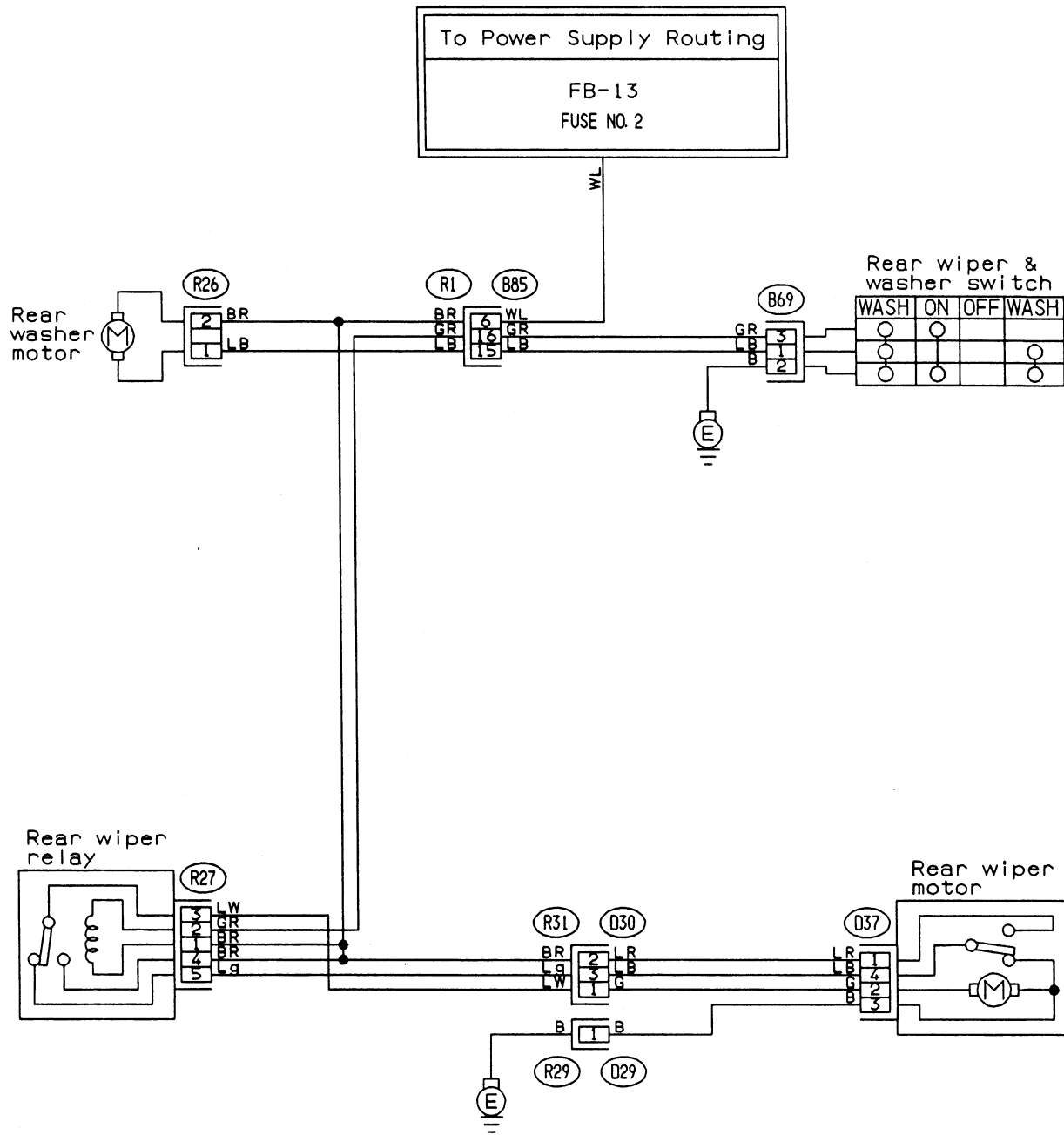

R26 (Green)

D29

D37

D30

R27 (Black)

B69

B85 (Blue)

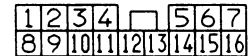
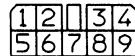

25. REMOTE CONTROL REARVIEW MIRROR SYSTEM

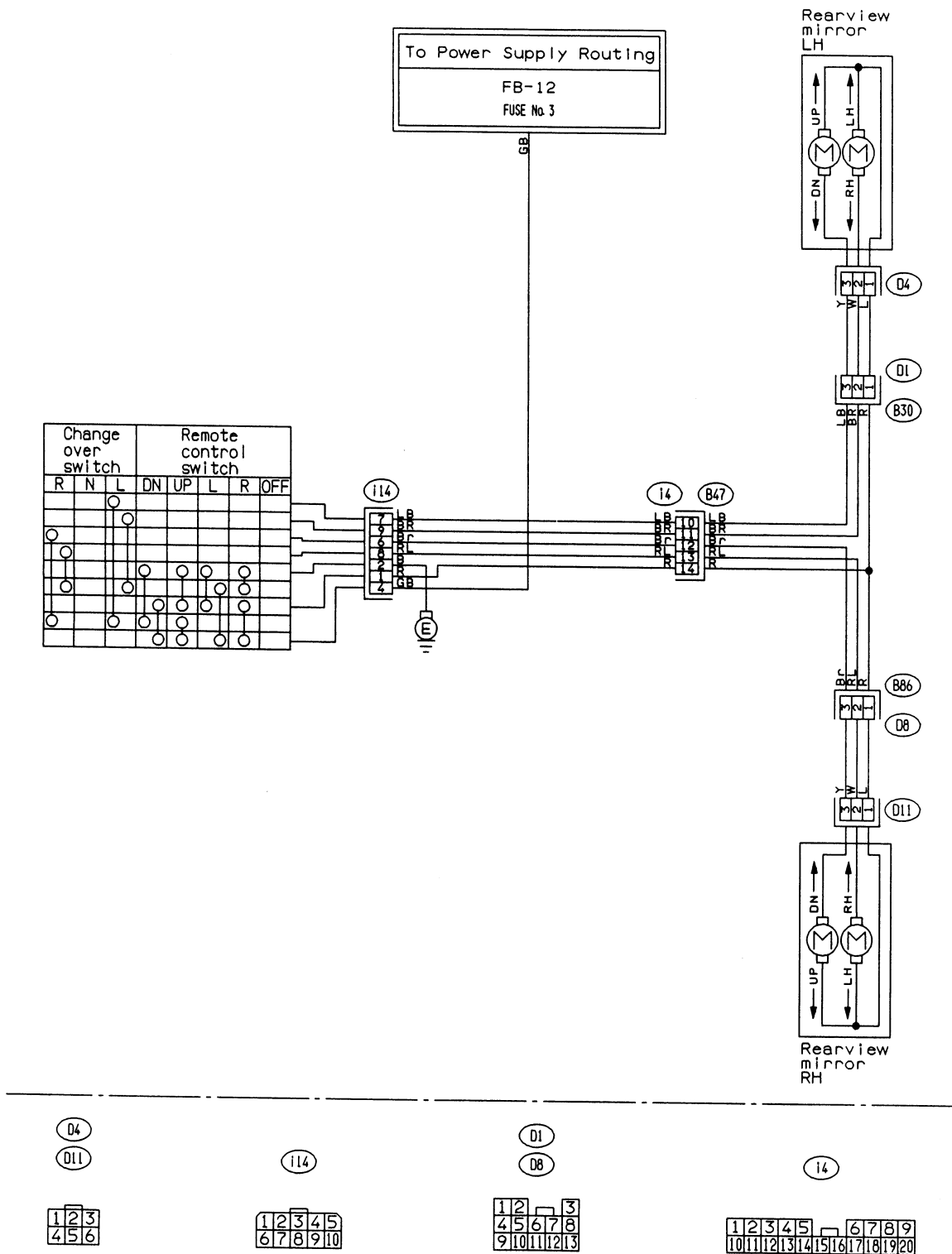

GU79-01

26. SEAT BELT WARNING AND KEY WARNING SYSTEM

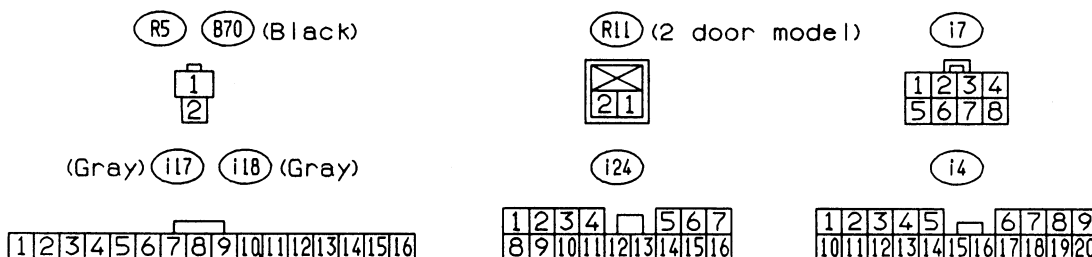
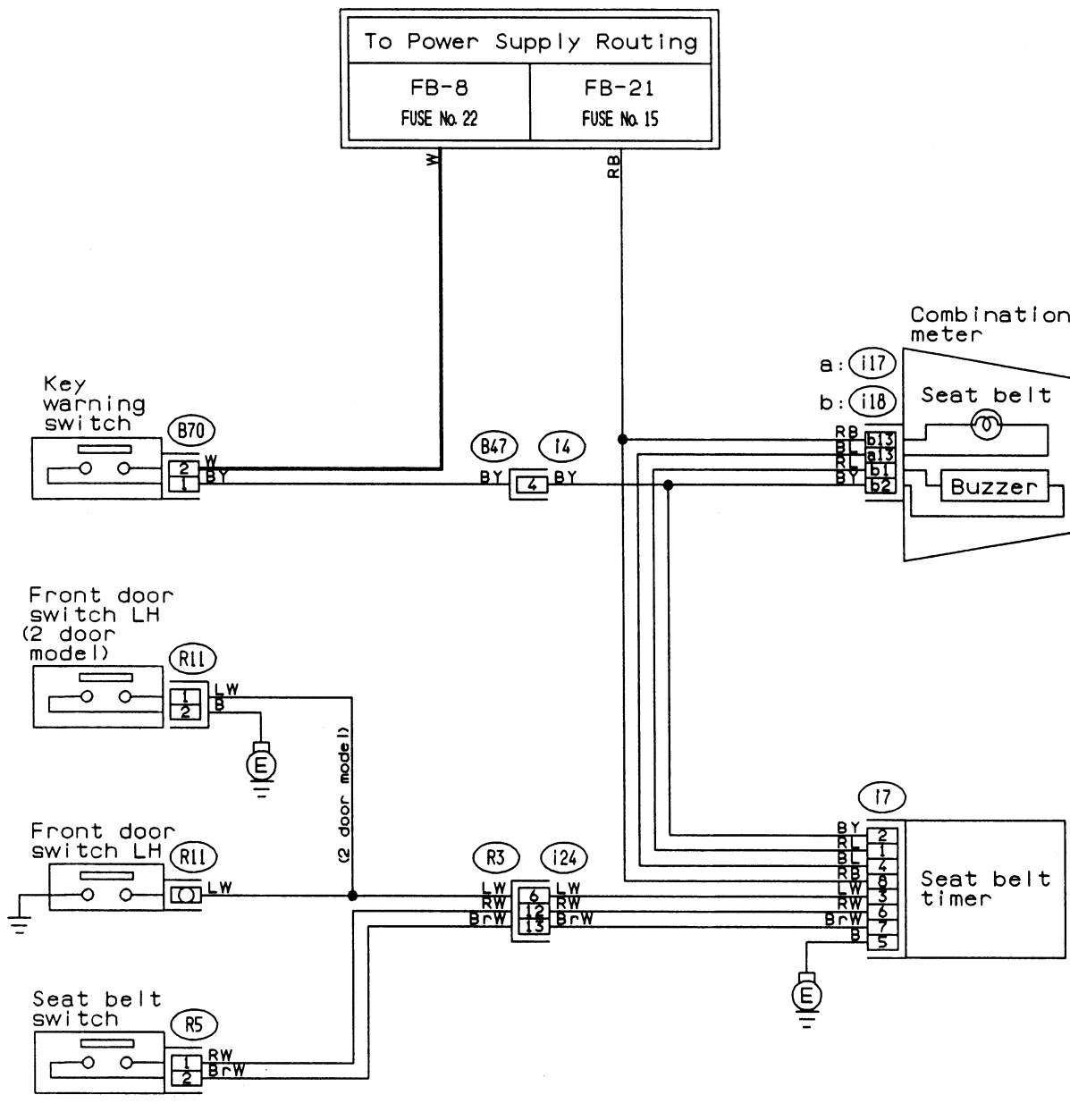

27. SPOT LIGHT, ROOM LIGHT, FUSE BOX LIGHT, LUGGAGE AND TRUNK ROOM LIGHT SYSTEM

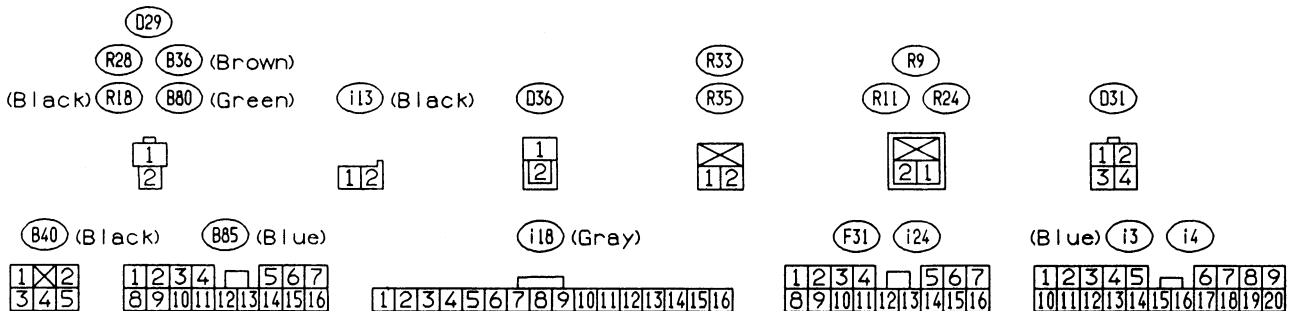
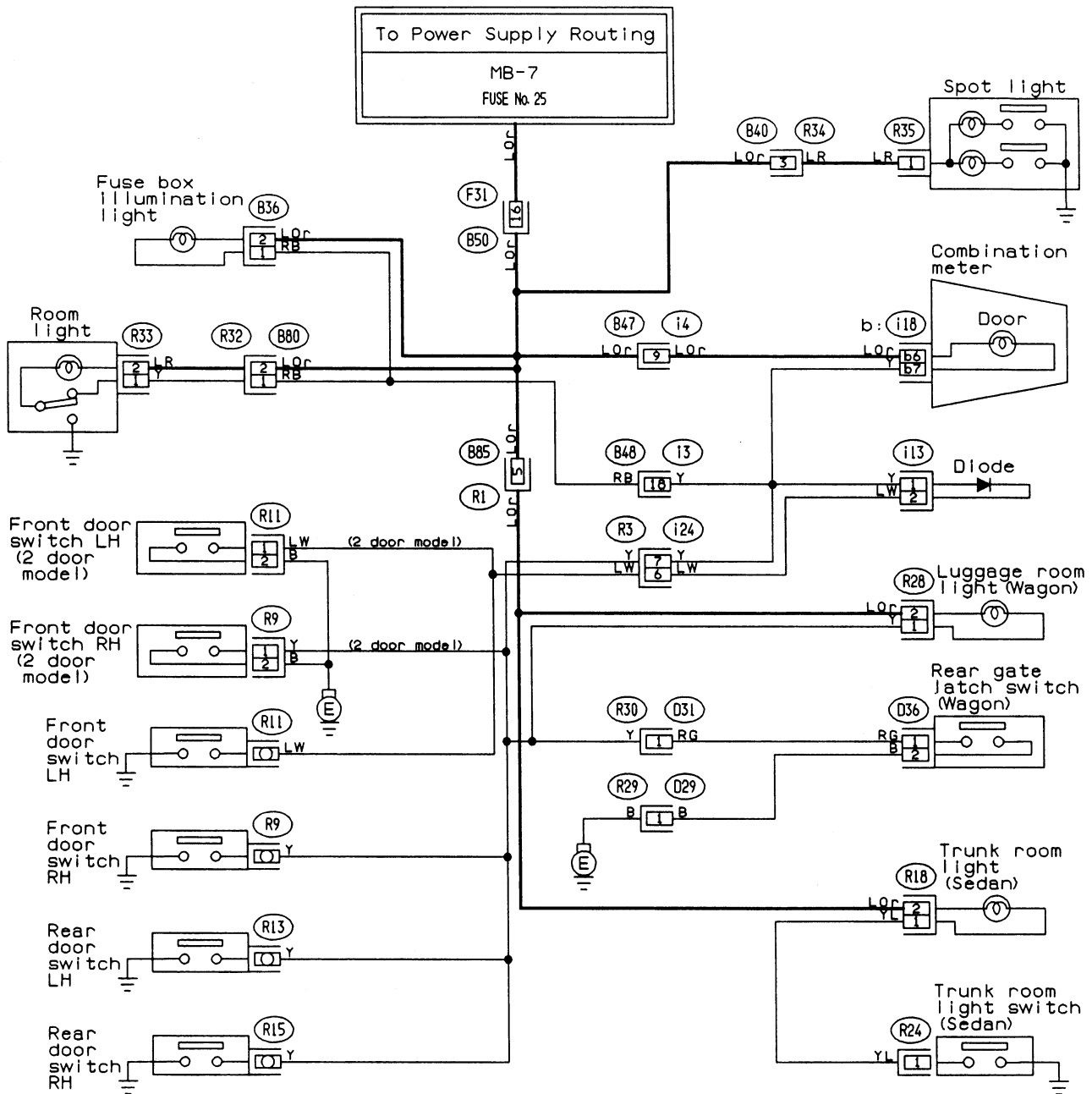

28. SRS (AIRBAG SYSTEM)

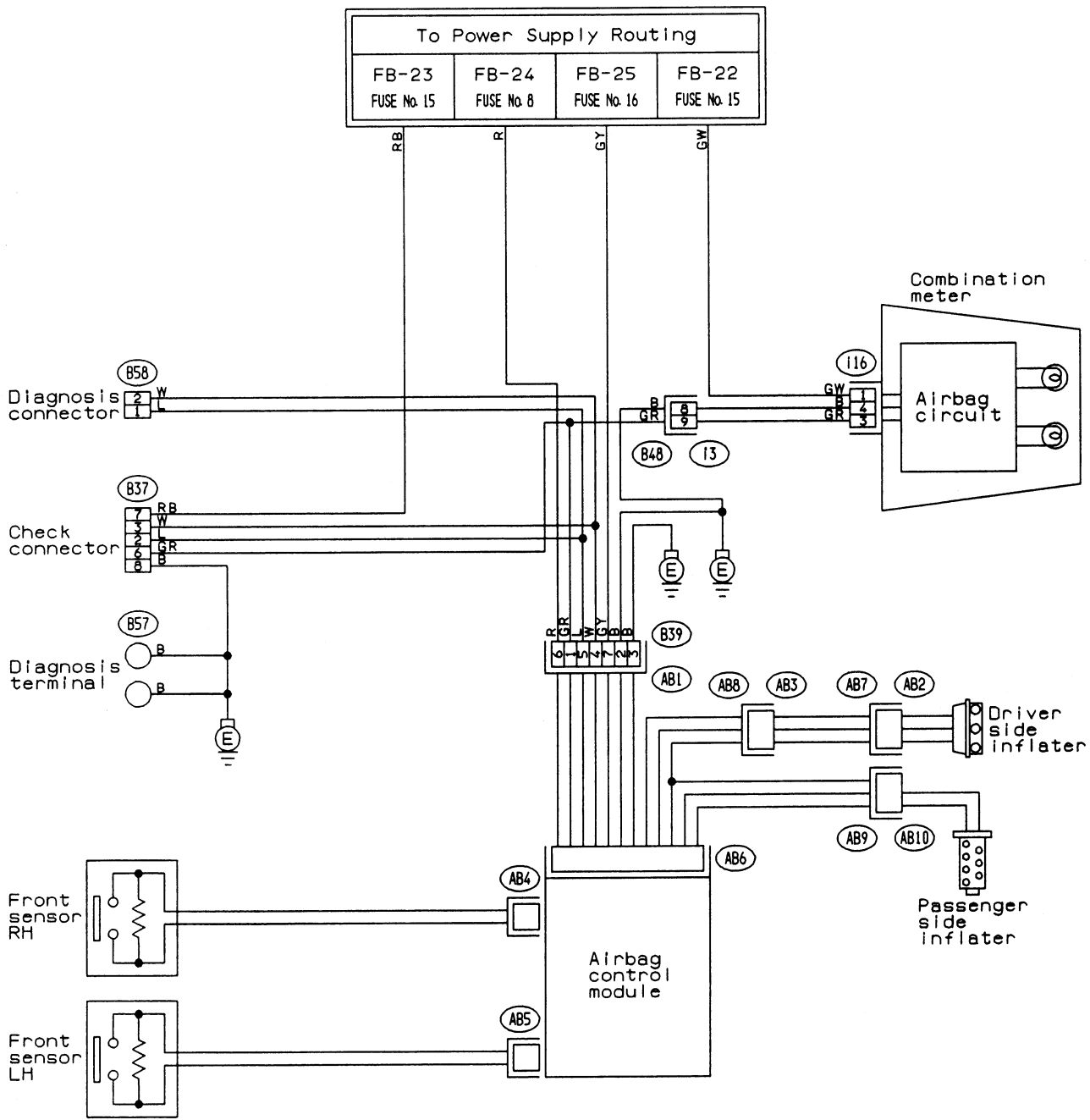

(116)

(B58) (Black)

(B39) (Yellow)



(B37) (Gray)

(13) (Blue)

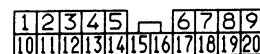

29. STARTING SYSTEM

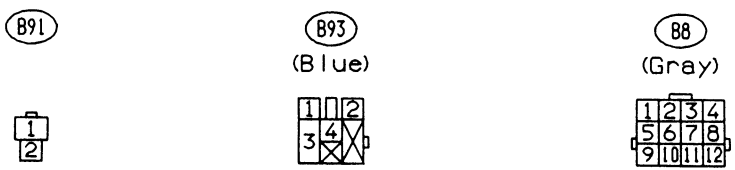
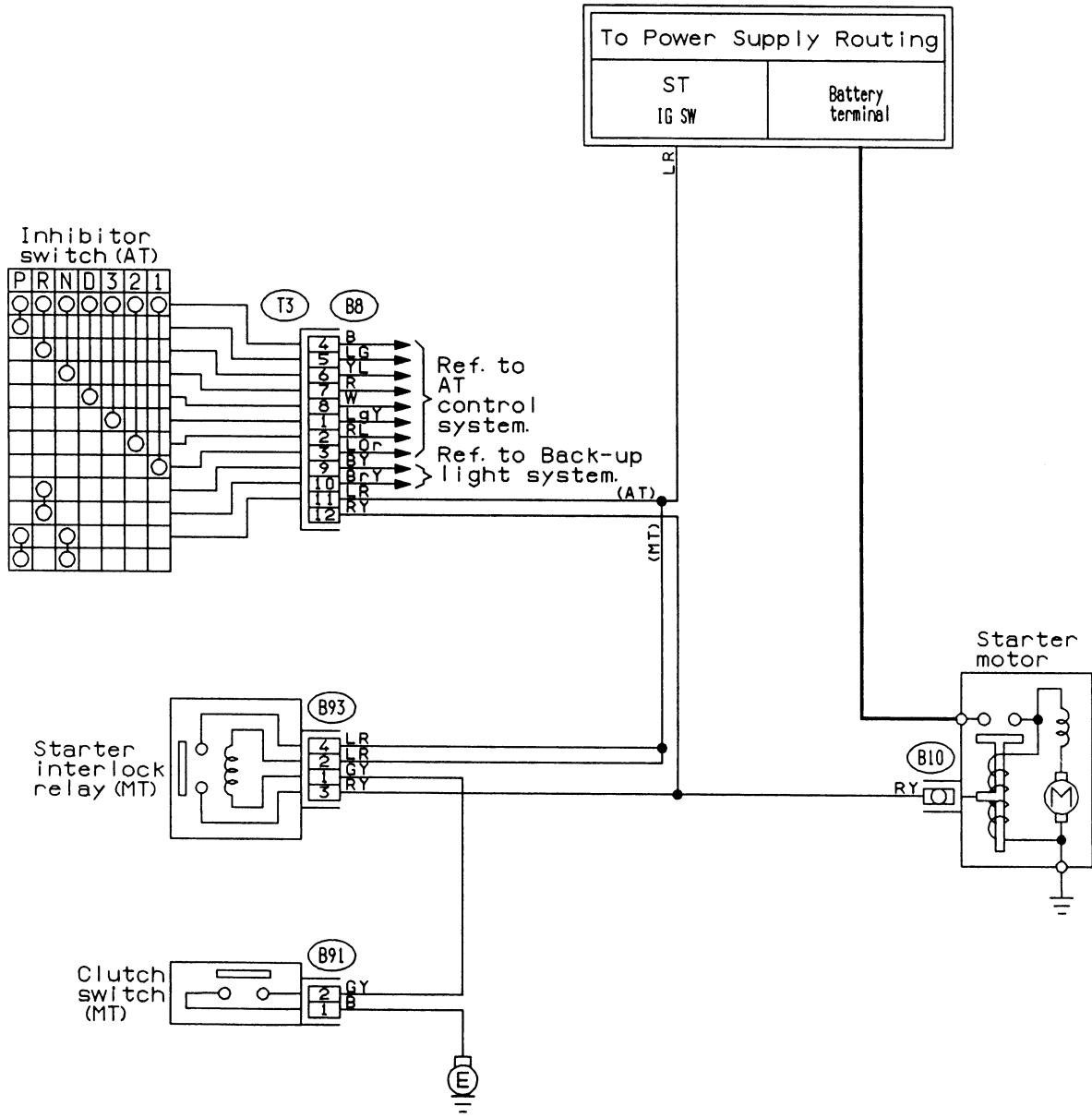

30. STOP LIGHT SYSTEM

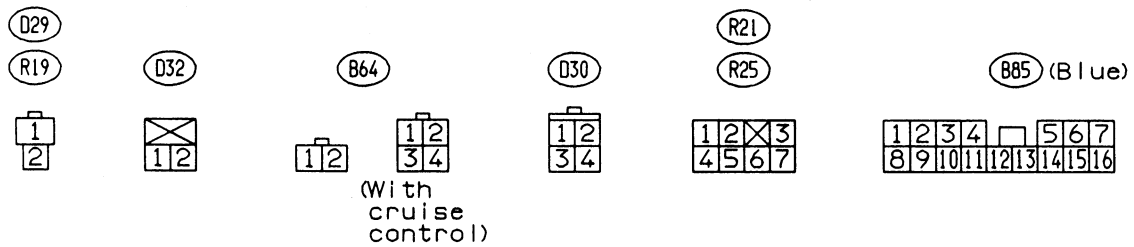
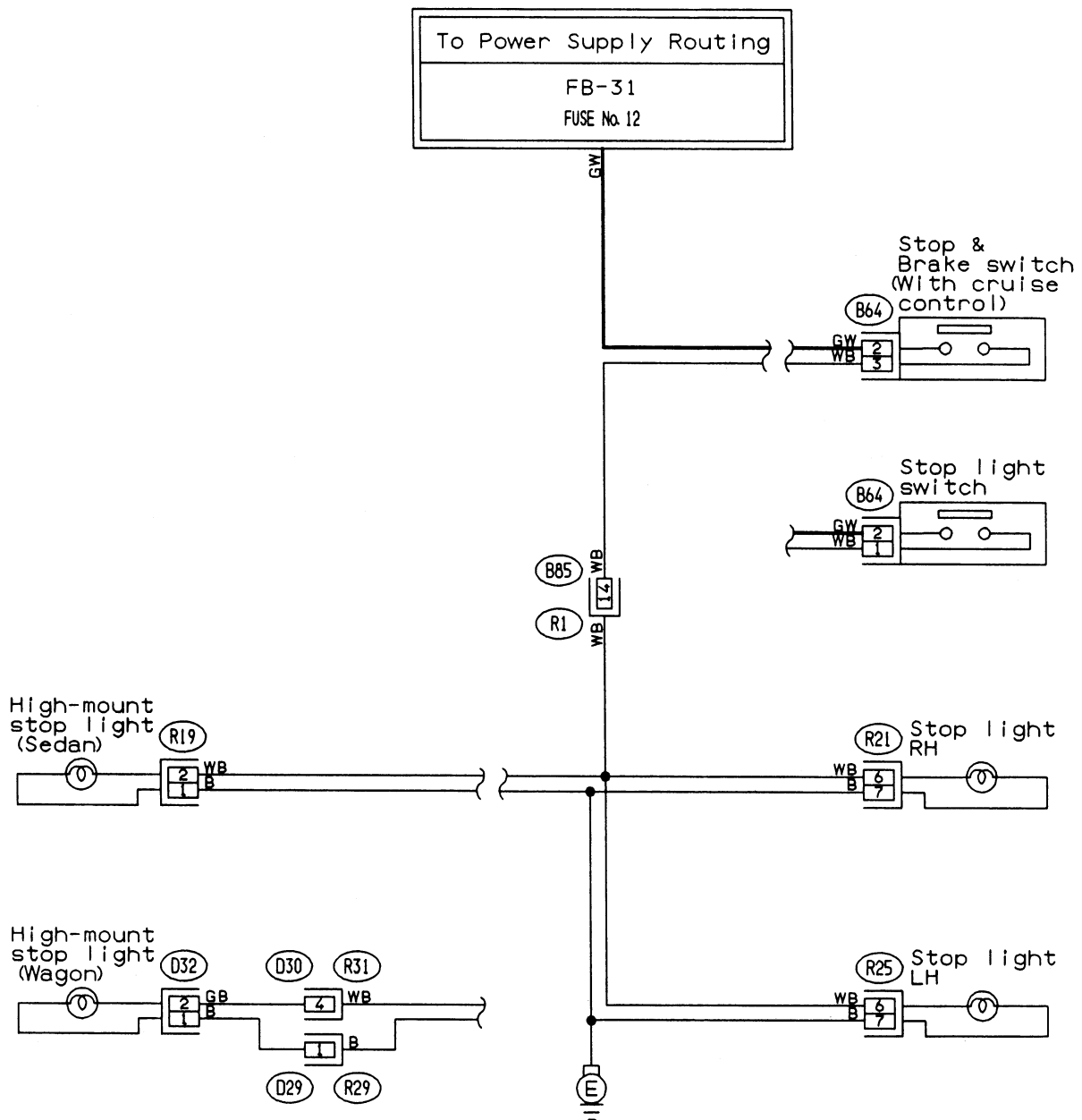

31. SUNROOF SYSTEM

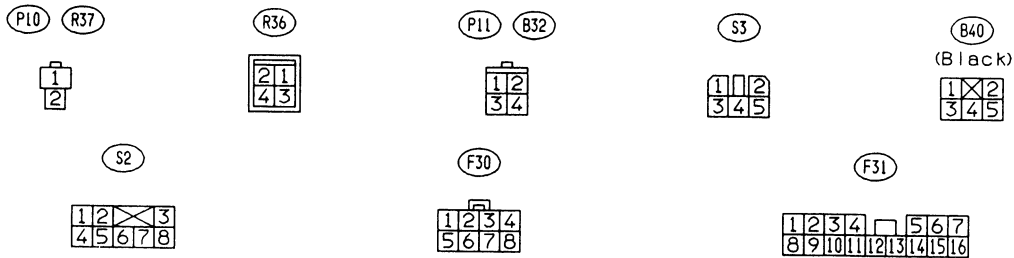
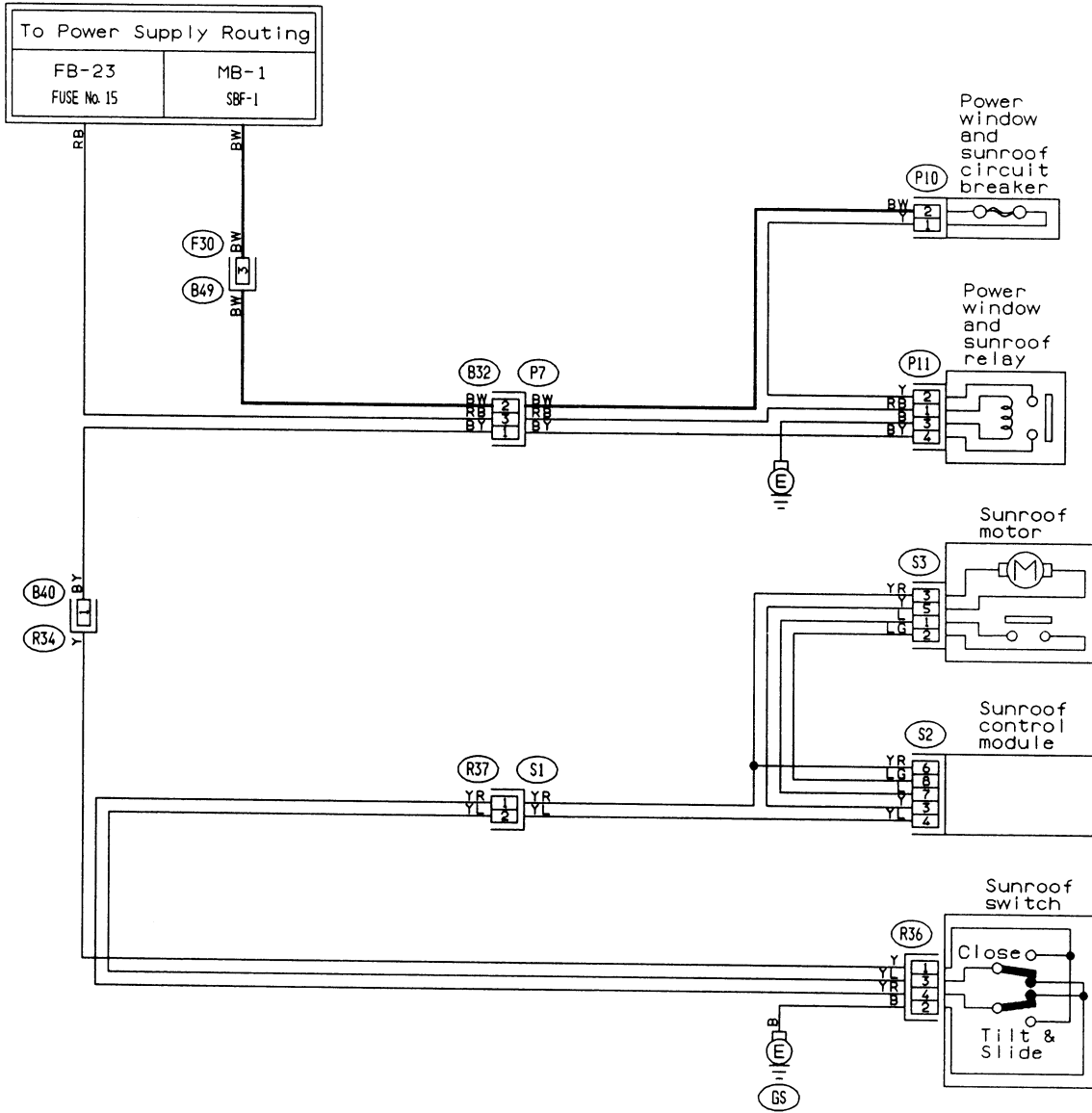

32. TURN SIGNAL AND HAZARD SYSTEM

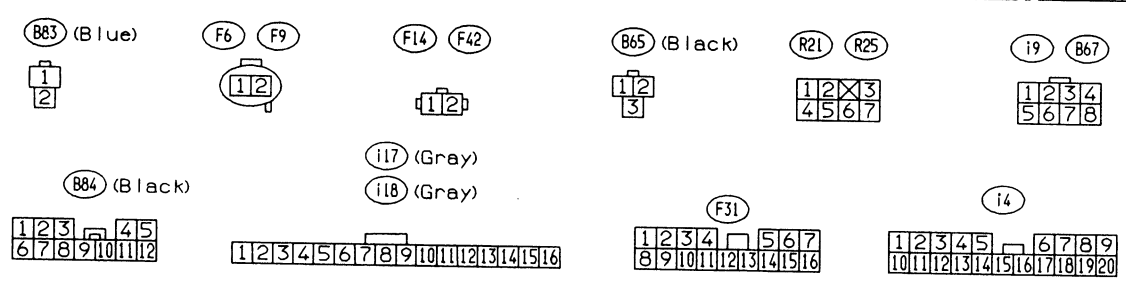
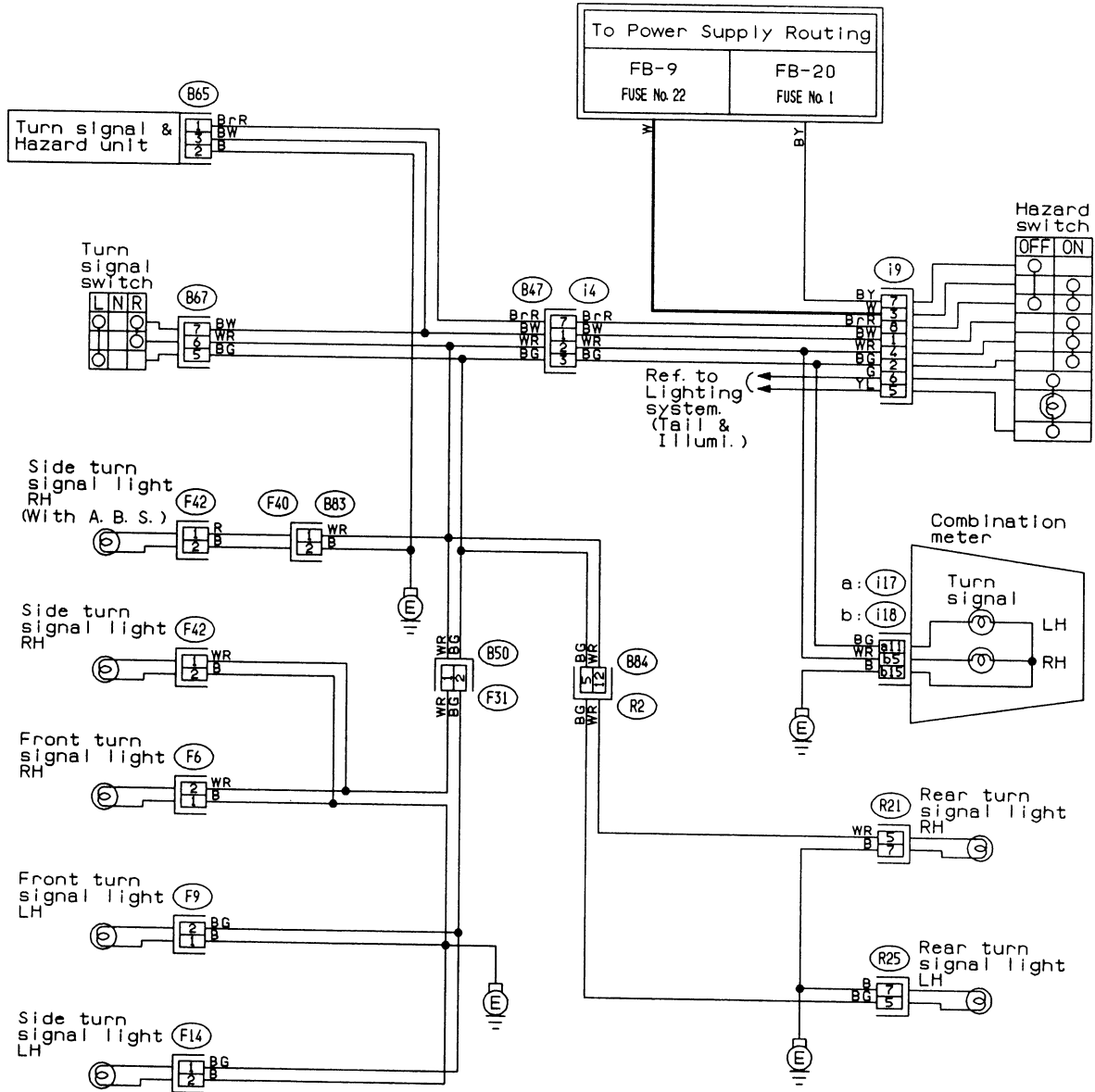

GU26-01

33. FRONT FOG LIGHT SYSTEM

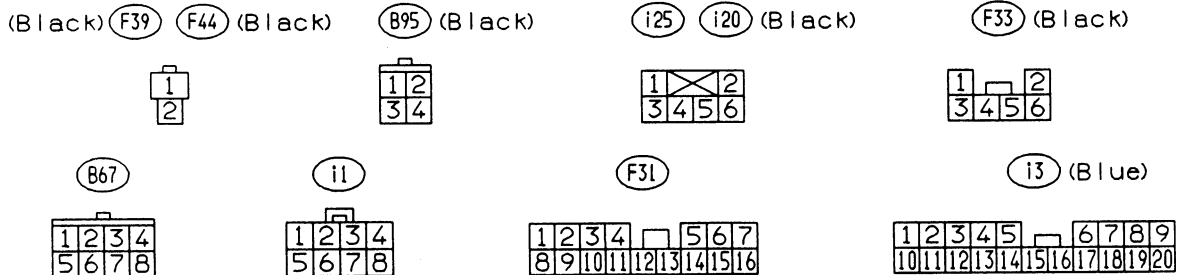
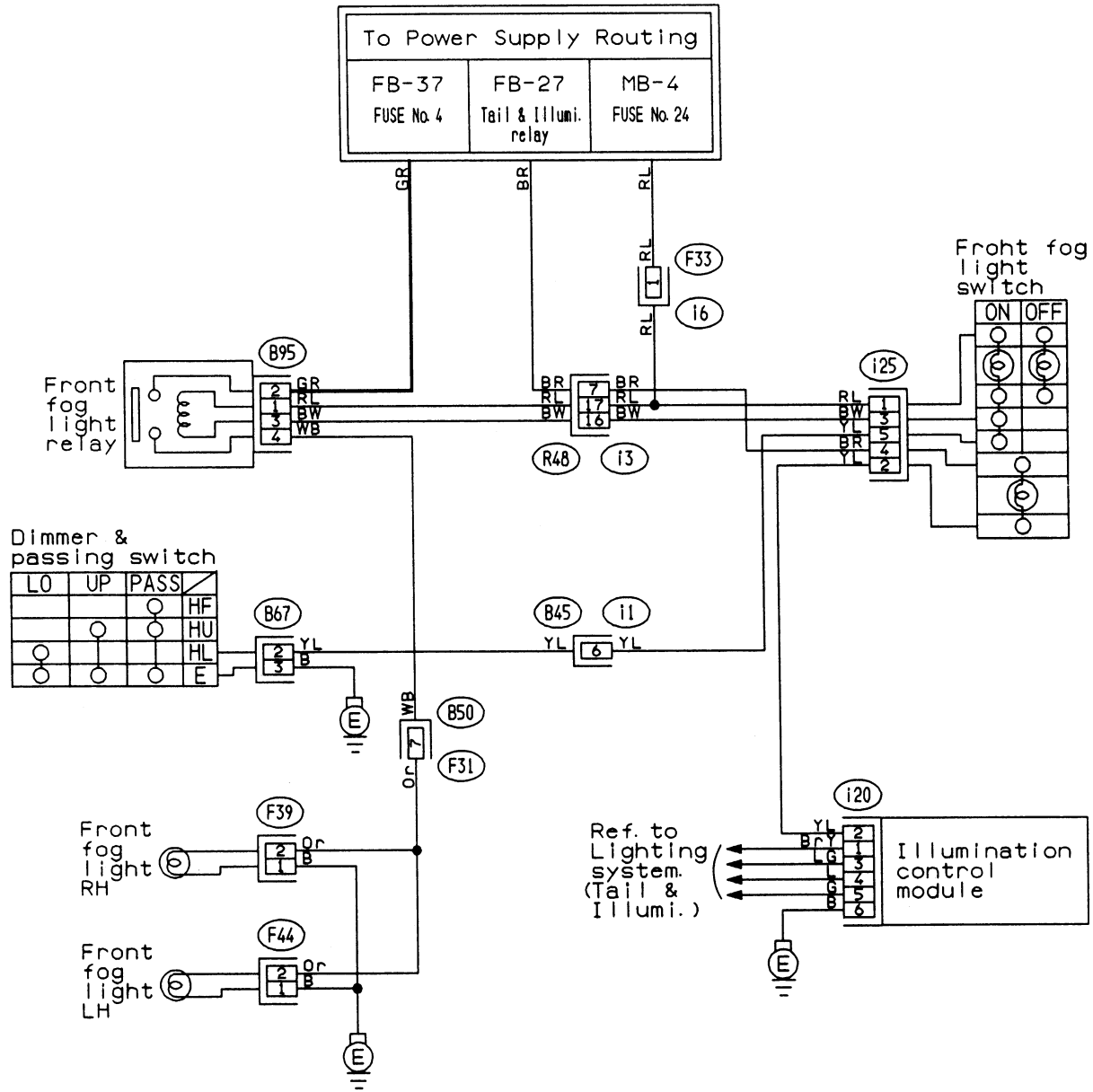

GU22-01