

3-2 [T7A0] AUTOMATIC TRANSMISSION AND DIFFERENTIAL

7. Diagnostics for On-board Diagnostics Failed

7. Diagnostics for On-board Diagnostics Failed

A: AT OIL TEMP INDICATOR LIGHT

DIAGNOSIS:

The AT OIL TEMP indicator light circuit is open or shorted.

TROUBLE SYMPTOM:

- When ignition switch is turned to ON (engine OFF), AT OIL TEMP indicator light does not illuminate.
- When on-board diagnostics is performed, AT OIL TEMP indicator light remains illuminated.

WIRING DIAGRAM:

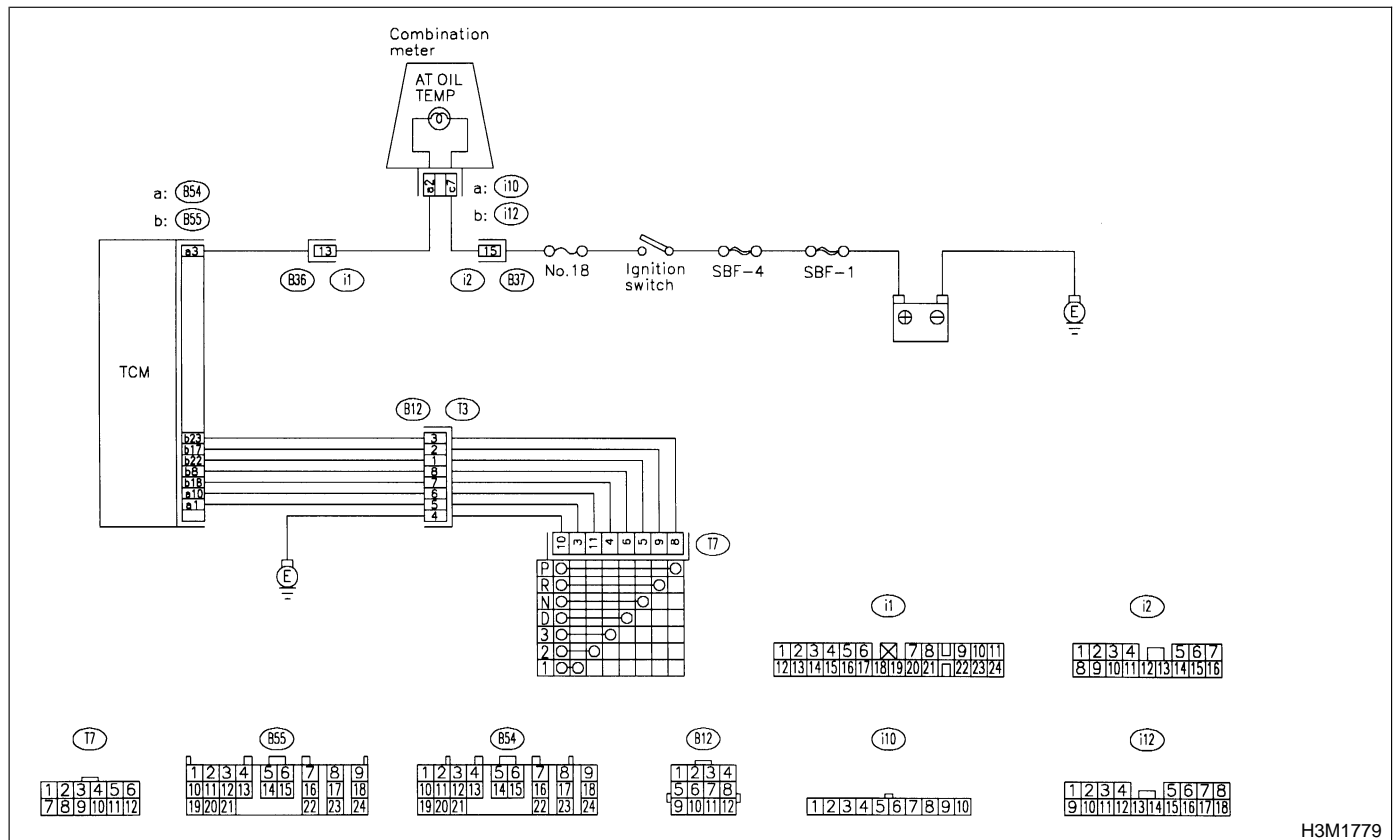

H3M1779

7A1 : CHECK AT OIL TEMP INDICATOR LIGHT.

Turn ignition switch to ON (engine OFF).

CHECK : Does AT OIL TEMP indicator light illuminate?

YES : Go to step 7A2.

NO : Go to step 7A3.

7A2 : CHECK AT OIL TEMP INDICATOR LIGHT.

Perform on-board diagnostics. <Ref. to 3-2 [T6C0].>

CHECK : Does AT OIL TEMP indicator light blink?

YES : A temporary poor contact of the connector or harness may be the cause. Repair harness or connector in TCM, inhibitor switch and combination meter.

NO : Go to step 7A8.

7A3 : CHECK FUSE (NO. 18).

Remove fuse (No. 18).

- CHECK** : *Is the fuse (No. 18) blown out?*
- YES** : Replace fuse (No. 18). If replaced fuse (No. 18) is blown out easily, repair short circuit in harness between fuse (No. 18) and combination meter.
- NO** : Go to step **7A4**.

7A4 : CHECK HARNESS CONNECTOR BETWEEN COMBINATION METER AND IGNITION SWITCH.

- 1) Turn ignition switch to ON (engine OFF).
- 2) Measure voltage between combination meter connector and chassis ground.

Connector & terminal
(i12) No. 7 (+) — Chassis ground (-):

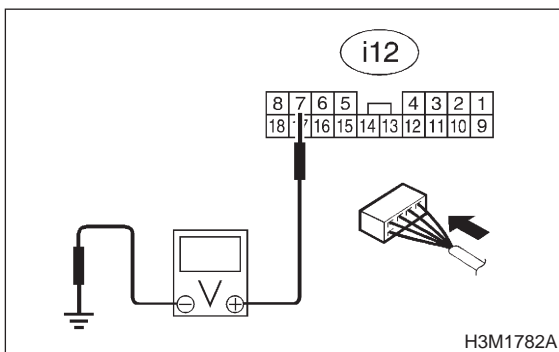

- CHECK** : *Is voltage more than 10 V?*
- YES** : Go to step **7A5**.
- NO** : Repair open circuit in harness between combination meter and fuse, and poor contact in coupling connector.

7A5 : CHECK COMBINATION METER.

Measure voltage between combination meter connector and chassis ground.

Connector & terminal
(i10) No. 2 (+) — Chassis ground (-):

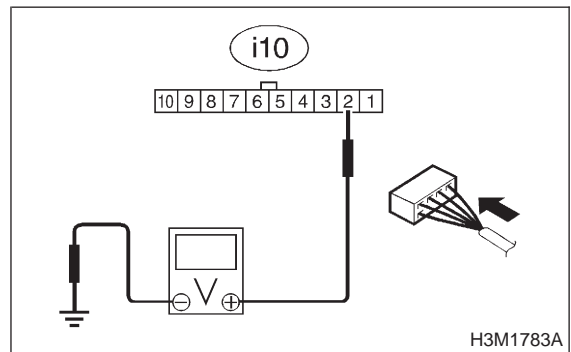

- CHECK** : *Is voltage less than 1 V?*
- YES** : Go to step **7A6**.
- NO** : Replace combination meter. <Ref. to 6-2 [W800].>

7A6 : CHECK OPEN CIRCUIT OF HARNESS.

- 1) Disconnect connector from combination meter connector.
- 2) Measure resistance of harness between combination meter.

Connector & terminal
(B54) No. 3 — (i10) No. 2:

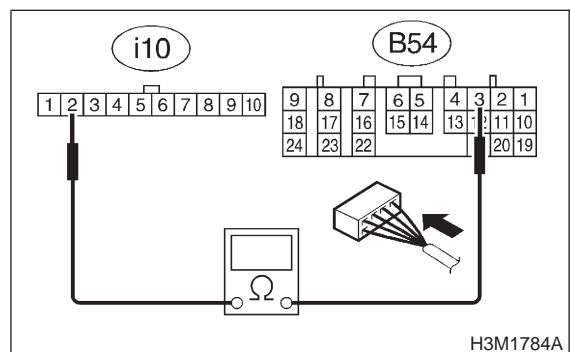

- CHECK** : *Is the resistance less than 1 Ω?*
- YES** : Go to step **7A7**.
- NO** : Repair open circuit in harness between TCM and combination meter, and poor contact in coupling connector.

3-2 [T7A7] AUTOMATIC TRANSMISSION AND DIFFERENTIAL

7. Diagnostics for On-board Diagnostics Failed

7A7 : CHECK INPUT SIGNAL FOR TCM.

- 1) Connect connector to TCM and combination meter.
- 2) Turn ignition switch to ON (engine OFF).
- 3) Measure voltage between TCM connector and chassis ground.

Connector & terminal

(B54) No. 3 (+) — Chassis ground (-):

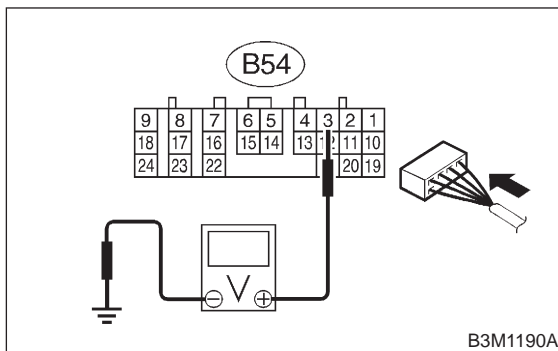

- CHECK** : **Is the voltage less than 1 V?**
- YES** : Even if AT OIL TEMP indicator lights up, the circuit has returned to a normal condition at this time. A temporary poor contact of the connector or harness may be the cause. Repair harness or connector in TCM.
- NO** : Replace TCM. <Ref. to 3-2 [W22A0].>

7A8 : CHECK INHIBITOR SWITCH.

- 1) Connect Subaru Select Monitor to data link connector.
 - 2) Turn ignition switch to ON.
 - 3) Subaru Select Monitor to ON.
 - 4) Read data of range switch using Subaru Select Monitor.
- Range switch is indicated in ON ⇔ OFF.

- CHECK** : **When each range is selected, does LED of Subaru Select Monitor light up?**
- YES** : Go to step **7A9**.
- NO** : Check inhibitor switch circuit. <Ref. to 3-2 [T9T0].>

7A9 : CHECK SHORT CIRCUIT OF HARNESS.

- 1) Disconnect connector from TCM.
- 2) Remove combination meter.
- 3) Disconnect connector from combination meter.
- 4) Measure resistance of harness connector between TCM and combination meter.

Connector & terminal/specified resistance (B54) No. 3 — Chassis ground:

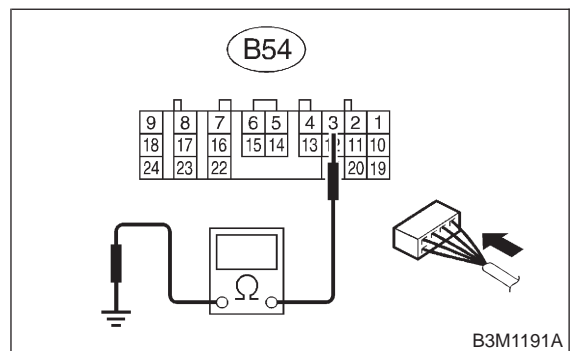

- CHECK** : **Is the resistance less than 1 MΩ?**
- YES** : Replace TCM. <Ref. to 3-2 [W22A0].>
- NO** : Repair short circuit in harness between combination meter connector and TCM connector.

MEMO:

3-2 [T7B0] AUTOMATIC TRANSMISSION AND DIFFERENTIAL

7. Diagnostics for On-board Diagnostics Failed

B: CONTROL MODULE POWER SUPPLY AND GROUND LINE

WIRING DIAGRAM:

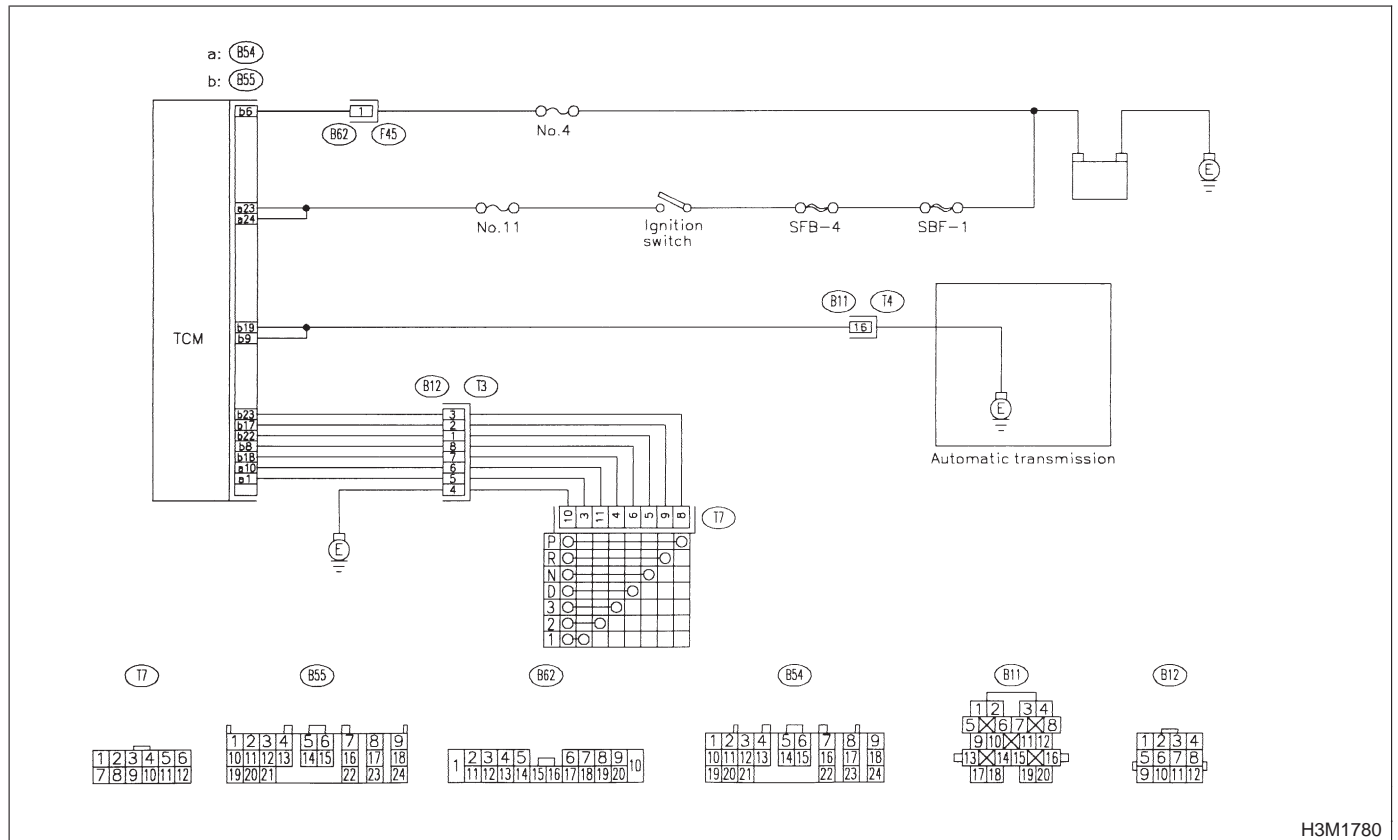

H3M1780

7B1 : CHECK BACK-UP POWER SUPPLY CIRCUIT.

- 1) Turn ignition switch to ON.
- 2) Measure back-up power supply voltage between TCM connector terminal.

Connector & terminal

(B55) No. 6 (+) — No. 19 (-):

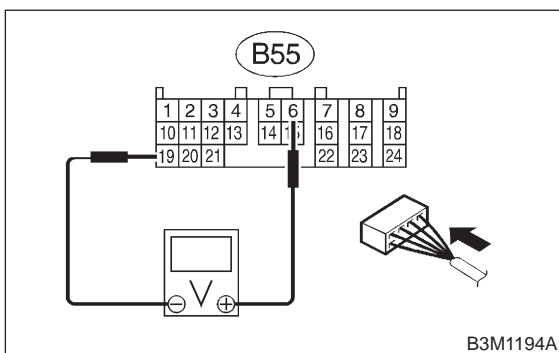

B3M1194A

- CHECK** : Is the voltage more than 10 V?
- YES** : Go to step 7B3.
- NO** : Go to step 7B2.

7B2 : CHECK FUSE (NO. 4).

Remove fuse (No. 4).

- CHECK** : Is the fuse (No. 4) blown out?
- YES** : Replace fuse (No. 4). If replaced fuse (No. 4) has blown out easily, repair short circuit in harness between fuse (No. 4) and TCM.
- NO** : Repair open circuit in harness between fuse (No. 4) and TCM, and poor contact in coupling connector.

7B3 : CHECK IGNITION POWER SUPPLY CIRCUIT.

- 1) Turn ignition switch to ON (engine OFF).
- 2) Measure ignition power supply voltage between TCM connector terminal.

Connector & terminal
(B54) No. 23 (+) — (B55) No. 19 (-):

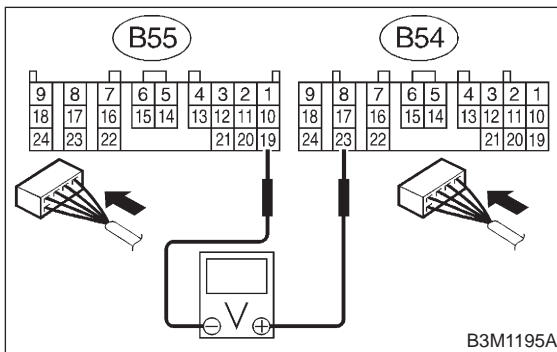

- CHECK** : *Is the voltage more than 10 V?*
YES : Go to step 7B4.
NO : Go to step 7B5.

7B4 : CHECK IGNITION POWER SUPPLY CIRCUIT.

- 1) Turn ignition switch to ON (engine OFF).
- 2) Measure ignition power supply voltage between TCM connector terminal.

Connector & terminal
(B54) No. 24 (+) — (B55) No. 19:

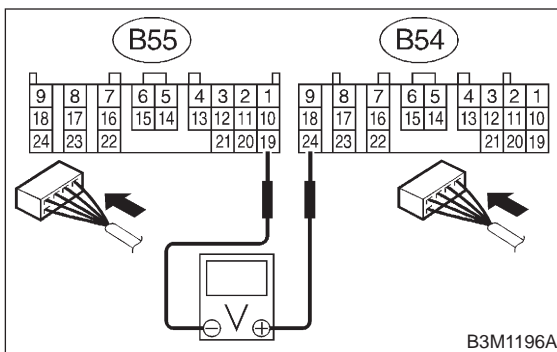

- CHECK** : *Is the voltage more than 10 V?*
YES : Go to step 7B6.
NO : Go to step 7B5.

7B5 : CHECK FUSE (NO. 11).

Remove fuse (No. 11).

- CHECK** : *Is the fuse (No. 11) blown out?*
YES : Replace fuse (No. 11). If replaced fuse (No. 11) has blown out easily, repair short circuit in harness between fuse (No. 11) and TCM.
NO : Repair open circuit in harness between fuse (No. 11) and TCM, and poor contact in coupling connector.

7B6 : CHECK HARNESS CONNECTOR BETWEEN TCM AND TRANSMISSION.

- 1) Turn ignition switch to OFF.
- 2) Disconnect connector from TCM and transmission.
- 3) Measure resistance of harness between TCM and transmission connector.

Connector & terminal
(B55) No. 19 — (B11) No. 16:

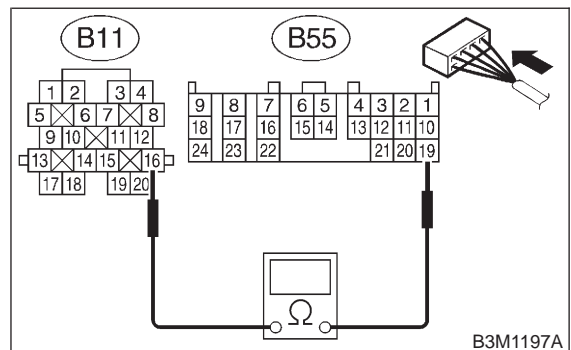

- CHECK** : *Is the resistance less than 1 Ω?*
YES : Go to step 7B7.
NO : Repair open circuit in harness between TCM and transmission harness connector.

3-2 [T7B7] AUTOMATIC TRANSMISSION AND DIFFERENTIAL

7. Diagnostics for On-board Diagnostics Failed

7B7 : CHECK HARNESS CONNECTOR BETWEEN TCM AND INHIBITOR SWITCH.

- 1) Turn ignition switch to OFF.
- 2) Disconnect connector from inhibitor switch.
- 3) Measure resistance of harness between inhibitor switch side connector and chassis ground.

Connector & terminal

(T7) No. 10 — (B55) No. 9:

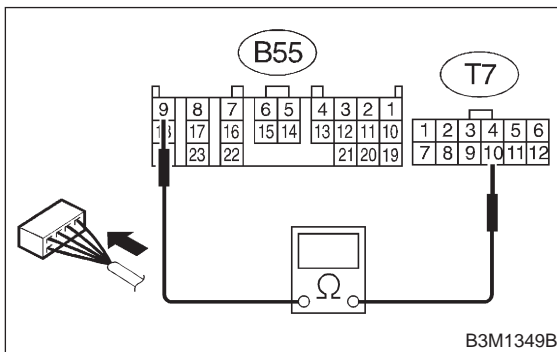

- CHECK** : Is the resistance less than 1 Ω?
- YES** : Go to step 7B8.
- NO** : Repair open circuit in harness between TCM and inhibitor side connector, and poor contact in coupling connector.

7B8 : CHECK HARNESS CONNECTOR BETWEEN TRANSMISSION AND TRANSMISSION GROUND.

Measure resistance of harness between transmission and transmission ground.

Connector & terminal

(T4) No. 16 — Transmission ground:

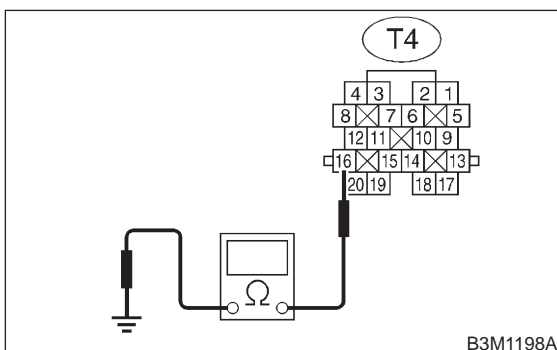

- CHECK** : Is the resistance less than 1 Ω?
- YES** : Go to step 7B9.
- NO** : Repair open circuit in harness between transmission and transmission ground.

7B9 : CHECK POOR CONTACT.

- CHECK** : Is there poor contact in control module power supply and ground line?
- YES** : Repair poor contact and ground terminal.
- NO** : Replace TCM. <Ref. to 3-2 [W22A0].>