

1. Precaution

A: SUPPLEMENTAL RESTRAINT SYSTEM “AIRBAG”

Airbag system wiring harness is routed near the transmission control module (TCM).

CAUTION:

- All Airbag system wiring harness and connectors are colored yellow. Do not use electrical test equipment on these circuit.
- Be careful not to damage Airbag system wiring harness when performing diagnostics and servicing the TCM.

B: MEASUREMENT

When measuring voltage and resistance of the ECM, TCM or each sensor, use a tapered pin with a diameter of less than 0.64 mm (0.025 in) in order to avoid poor contact. Do not insert the pin more than 5 mm (0.20 in).

2. Pre-inspection

A: ATF LEVEL

Make sure that ATF level is in the specification.

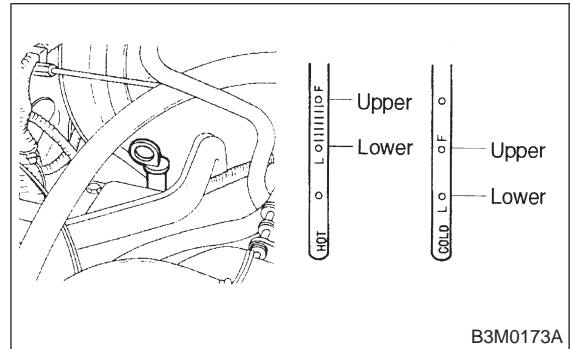

B: FRONT DIFFERENTIAL OIL LEVEL

Make sure that front differential oil level is in the specification.

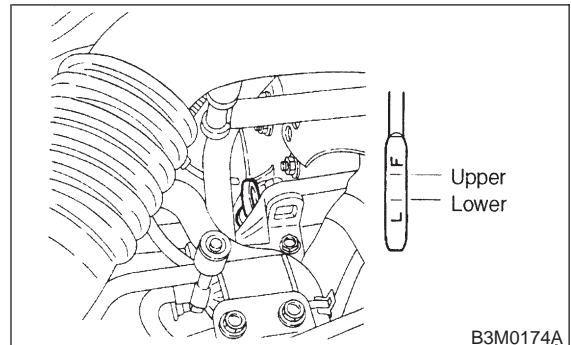

C: OPERATION OF SHIFT SELECTOR LEVER

WARNING:

Stop the engine while checking operation of selector lever.

- 1) Check that selector lever does not move from "N" to "R" without pushing the button.
- 2) Check that selector lever does not move from "R" to "P" without pushing the button.
- 3) Check that selector lever does not move from "P" to "R" without pushing the button.
- 4) Check that selector lever does not move from "3" to "2" without pushing the button.

