

1. Precaution

A: SUPPLEMENTAL RESTRAINT SYSTEM "AIRBAG"

Airbag system wiring harness is routed near the cruise control module and cruise control command switch.

CAUTION:

- All Airbag system wiring harness and connectors are colored yellow. Do not use electrical test equipment on these circuits.
- Be careful not to damage Airbag system wiring harness when servicing the cruise control module and cruise control command switch.

2. Pre-inspection

A: FUNCTION TESTS

Conduct road tests by selecting a smooth, flat road or use free rollers for road test simulation.

1. CRUISE CONTROL MAIN SWITCH

- 1) Turn ignition switch to ON.
- 2) Check that cruise control main switch indicator light comes on when main switch is pressed (ON).
- 3) Check that main switch indicator light goes out when main switch is pressed again (OFF).
- 4) Turn ignition switch to OFF with main switch ON (indicated by illumination). Turn ignition switch ON again to ensure that main switch indicator light remains OFF.

2. CRUISE CONTROL COMMAND SWITCH

- 1) Check that cruise control command switch is properly set in "SET/COAST", "RESUME/ACCEL", or "CANCEL" mode.
- 2) Also check that command switch returns to the original position when released.

3. CONSTANT SPEED TEST

- 1) Turn cruise control main switch to ON.
- 2) Drive the vehicle at a speed greater than 40 km/h (25 MPH).
- 3) Press command switch to set in "SET/COAST" mode.
- 4) Ensure that vehicle is maintained at the speed set when command switch was pressed.

4. ACCELERATION TEST

- 1) Set vehicle speed at a speed greater than 40 km/h (25 MPH).
- 2) Ensure that vehicle continues to accelerate while holding command switch in "RESUME/ACCEL" mode, and that vehicle maintains that optional speed when command switch is released.

5. DECELERATION TEST

- 1) Set vehicle speed at an optional speed greater than 40 km/h (25 MPH).
- 2) Ensure that vehicle continues to decelerate while holding command switch in "SET/COAST" mode, and that it maintains that optional speed when command switch is released.

NOTE:

When vehicle speed reaches the lower speed limit of 30 km/h (19 MPH) during deceleration, cruise control will be released.

B: CRUISE CONTROL CABLE

2B1 : CHECK CRUISE CONTROL CABLE.

Check cruise control cable installation.

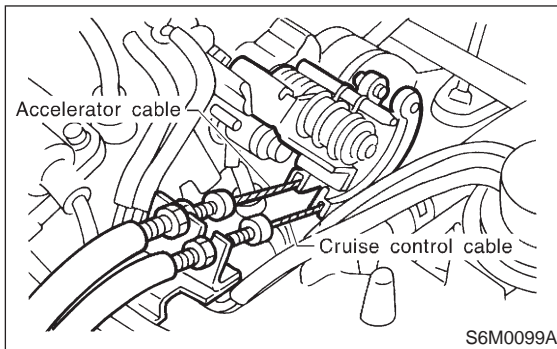

- CHECK** : *Is the cruise control cable securely installed to the left of the accelerator cable?*
- YES** : Go to step **2B2**.
- NO** : Install cruise control cable securely. Go to step **2B2**.

2B2 : CHECK ACCELERATOR CABLE.

Check function of accelerator cable.

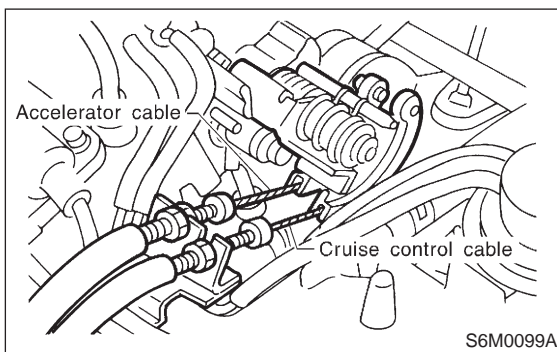

- CHECK** : *Does the accelerator cable throttle cam move when the cruise control throttle is moved by hand?*
- YES** : Repair accelerator cable throttle cam. Go to step **2B3**.
- NO** : Go to step **2B3**.

2B3 : CHECK THROTTLE CAM.

Check function of throttle cam.

- CHECK** : *Does the throttle cam move smoothly?*
- YES** : Go to step **2B4**.
- NO** : Repair throttle cam. Go to step **2B4**.

2B4 : CHECK CABLE FREE PLAY.

Ensure that throttle cam-to-lever clearance is within specifications.

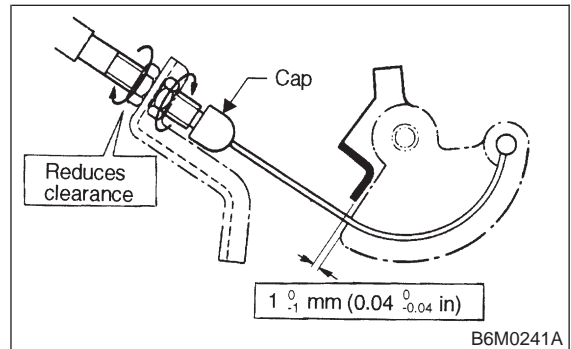

- CHECK** : *Is throttle cam-to-lever clearance between 0 and 1 mm (0 and 0.04 in)?*
- YES** : Go to step **2C1**.
- NO** : Adjust cable end by adjusting nuts. Go to step **2C1**.

NOTE:

Ensure that cap is positioned in groove.

C: VACUUM HOSE

2C1 : CHECK VACUUM HOSE VISUALLY.

Check vacuum hose (which connects actuator and intake manifold).

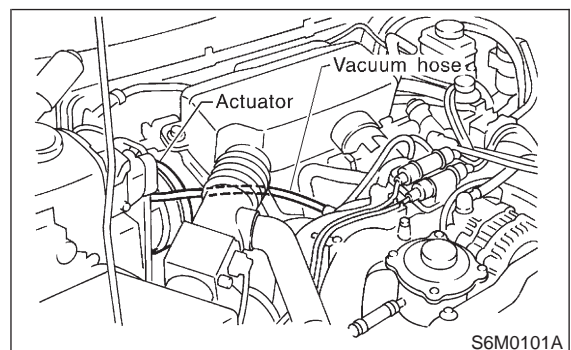

- CHECK** : *Is there disconnection or cracks in vacuum hose?*
- YES** : Replace vacuum hose. Go to step **2D1**.
- NO** : Go to step **2D1**.

6-2 [T2D1] BODY ELECTRICAL SYSTEM (CRUISE CONTROL)

2. Pre-inspection

D: ACTUATOR

2D1 : CHECK FUNCTION OF ACTUATOR.

- 1) Disconnect vacuum hose from actuator.

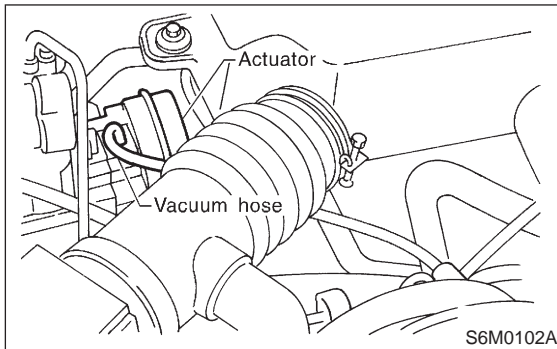

- 2) Connect vacuum pump as shown in figure.

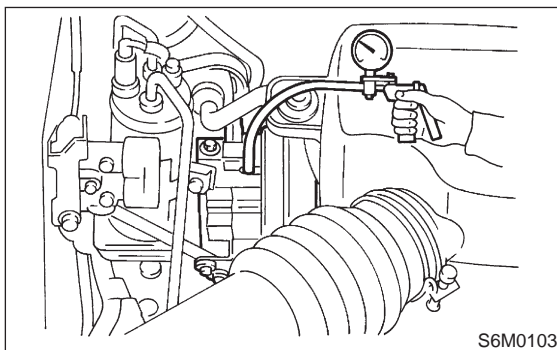

- 3) Make sure that cruise control cable moves smoothly and quickly when a vacuum pressure of 40.0 kPa (300 mmHg, 11.81 inHg) is applied to actuator.

CHECK : Does cruise control cable have a stroke of 35 mm (1.38 in)?

YES : Go to step 2D2.

NO : Replace actuator. <Ref. to 6-2 [W11B1].> Go to step 2D2.

NOTE:

- When vacuum pressure is released from condition 3) above, make sure the cable returns to its original position smoothly and quickly.
- After inspection, disconnect vacuum pump and connect vacuum hose.

2D2 : MEASURE RESISTANCE OF VALVE.

- 1) Disconnect connector from actuator.
- 2) Measure resistance between terminals of actuator.

Terminals

No. 2 — No. 3:

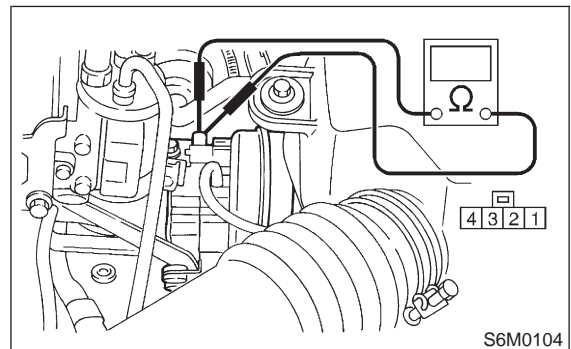

CHECK : Is resistance less than 100 Ω ?

YES : Go to step 2D3.

NO : Replace actuator. <Ref. to 6-2 [W11B1].>

2D3 : MEASURE RESISTANCE OF VALVE.

Measure resistance between terminals of actuator.

Terminals

No. 2 — No. 1:

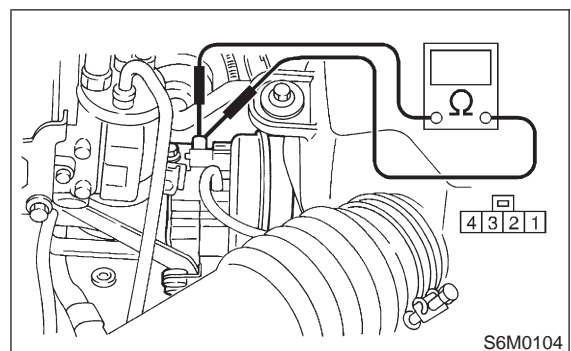

CHECK : Is resistance less than 69 Ω ?

YES : Go to step 2D4.

NO : Replace actuator. <Ref. to 6-2 [W11B1].>

2D4 : MEASURE RESISTANCE OF VALVE.

Measure resistance between terminals of actuator.

Terminals

No. 2 — No. 4:

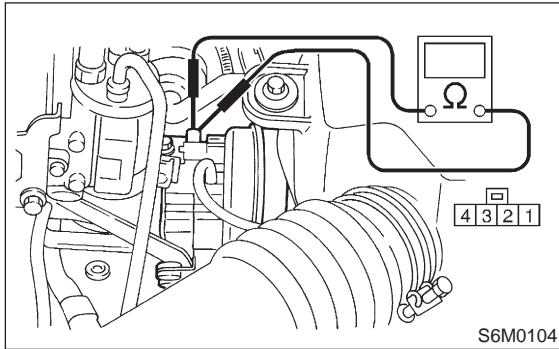

- CHECK** : *Is resistance less than 69 Ω?*
YES : Go to step **2D5**.
NO : Replace actuator. <Ref. to 6-2 [W11B1].>

2D5 : CHECK FOR LEAKAGE AND STICKING OF VALVES.

- 1) Disconnect connector from actuator.
- 2) Make sure that cruise control cable moves smoothly when connecting + (positive) battery cable to terminal No. 2 and – (negative) battery cable to terminals No. 1, 3 and 4 of actuator connector.

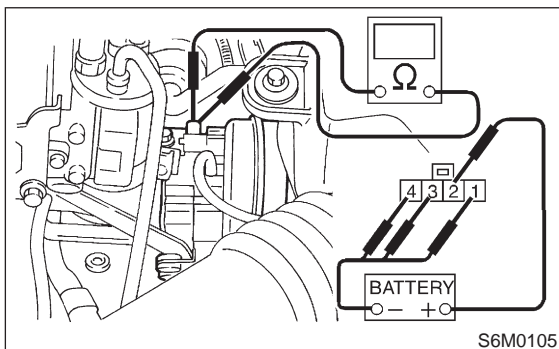

- CHECK** : *Does cruise control cable have a stroke of 35 mm (1.38 in) within 3 seconds?*
YES : Go to step **2D6**.
NO : Replace actuator. <Ref. to 6-2 [W11B1].> Go to step **2D6**.

2D6 : CHECK FOR LEAKAGE AND STICKING OF VALVES.

When the battery cable is disconnected from former condition <Ref. to 6-2 [T2D5].> Step 2), make sure the cable returns to its original position smoothly.

- CHECK** : *Does cruise control cable get back to its original position within 1.5 seconds?*
YES : Go to step **2D7**.
NO : Replace actuator. <Ref. to 6-2 [W11B1].> Go to step **2D7**.

2D7 : CHECK CABLE MOVEMENT.

Connect + (positive) battery cable to terminal No. 2 and – (negative) battery cable to terminals No. 1, 3 and 4 of actuator connector.

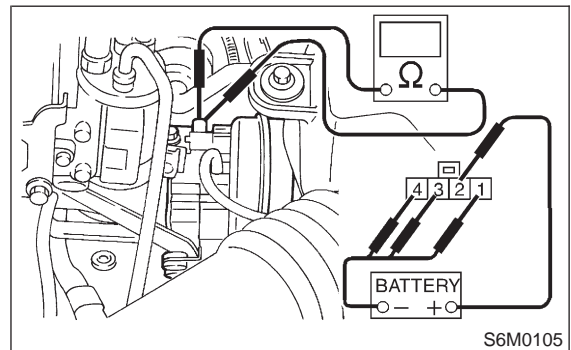

- CHECK** : *Does cruise control perform pull operation?*
YES : Go to step **2D8**.
NO : Replace actuator. <Ref. to 6-2 [W11B1].> Go to step **2D8**.

6-2 [T2D8] BODY ELECTRICAL SYSTEM (CRUISE CONTROL)

2. Pre-inspection

2D8 : CHECK CABLE MOVEMENT.

Connect + (positive) battery cable to terminal No. 2 and – (negative) battery cable to terminals No. 1 and 4 of actuator connector.

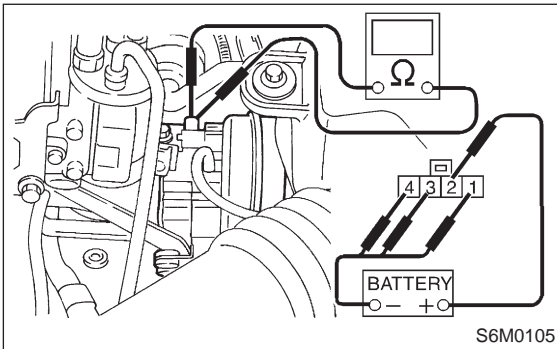

- CHECK** : **Does cruise control perform hold operation?**
- YES** : Go to step 2D9.
- NO** : Replace actuator. <Ref. to 6-2 [W11B1].> Go to step 2D9.

2D9 : CHECK CABLE MOVEMENT.

Connect + (positive) battery cable to terminal No. 2 and – (negative) battery cable to terminal No. 4 of actuator connector.

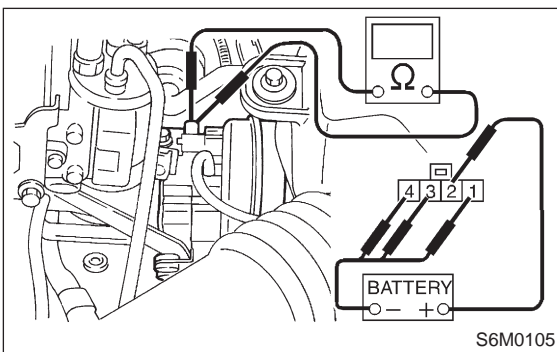

- CHECK** : **Does cruise control perform release operation?**
- YES** : Go to step 2E1.
- NO** : Replace actuator. <Ref. to 6-2 [W11B1].> Go to step 2E1.

E: POWER SUPPLY

2E1 : CHECK BATTERY.

Measure battery specific gravity of electrolyte.

- CHECK** : **Is battery specific gravity more than 1.250?**
- YES** : Go to step 2E2.
- NO** : Charge or replace battery. <Ref. to 6-2 [W2A0].> Go to step 2E2.

2E2 : CHECK FUSES, CONNECTORS AND HARNESSSES.

Check the condition of the main and other fuses, and harnesses and connectors. Also check for proper grounding.

- CHECK** : **Is there anything unusual about the appearance of main fuse, fuse, harness, connector and grounding?**
- YES** : Repair or replace faulty parts. End of pre-inspection.
- NO** : End of pre-inspection.