

11. Diagnostics Chart with Trouble Code for Except 2200 cc California Spec. Vehicles

A: DIAGNOSTIC TROUBLE CODE (DTC) LIST

DTC No.	Item	Index
P0101	Mass air flow sensor circuit range/performance problem (high input)	<Ref. to 2-7 [T11B0].>
P0102	Mass air flow sensor circuit low input	<Ref. to 2-7 [T11C0].>
P0103	Mass air flow sensor circuit high input	<Ref. to 2-7 [T11D0].>
P0106	Pressure sensor circuit range/performance problem	<Ref. to 2-7 [T11E0].>
P0107	Pressure sensor circuit low input	<Ref. to 2-7 [T11F0].>
P0108	Pressure sensor circuit high input	<Ref. to 2-7 [T11G0].>
P0116	Engine coolant temperature sensor circuit low input	<Ref. to 2-7 [T11H0].>
P0117	Engine coolant temperature sensor circuit high input	<Ref. to 2-7 [T11I0].>
P0121	Throttle position sensor circuit range/performance problem (high input)	<Ref. to 2-7 [T11J0].>
P0122	Throttle position sensor circuit low input	<Ref. to 2-7 [T11K0].>
P0123	Throttle position sensor circuit high input	<Ref. to 2-7 [T11L0].>
P0125	Insufficient coolant temperature for closed loop fuel control	<Ref. to 2-7 [T11M0].>
P0130	Front oxygen sensor circuit malfunction	<Ref. to 2-7 [T11N0].>
P0133	Front oxygen sensor circuit slow response	<Ref. to 2-7 [T11O0].>
P0135	Front oxygen sensor heater circuit malfunction	<Ref. to 2-7 [T11P0].>
P0136	Rear oxygen sensor circuit malfunction	<Ref. to 2-7 [T11Q0].>
P0139	Rear oxygen sensor circuit slow response	<Ref. to 2-7 [T11R0].>
P0141	Rear oxygen sensor heater circuit malfunction	<Ref. to 2-7 [T11S0].>
P0170	Fuel trim malfunction	<Ref. to 2-7 [T11T0].>
P0181	Fuel temperature sensor A circuit range/performance problem	<Ref. to 2-7 [T11U0].>
P0182	Fuel temperature sensor A circuit low input	<Ref. to 2-7 [T11V0].>
P0183	Fuel temperature sensor A circuit high input	<Ref. to 2-7 [T11W0].>
P0301	Cylinder 1 misfire detected	<Ref. to 2-7 [T11X0].>
P0302	Cylinder 2 misfire detected	<Ref. to 2-7 [T11Y0].>
P0303	Cylinder 3 misfire detected	<Ref. to 2-7 [T11Z0].>

ON-BOARD DIAGNOSTICS II SYSTEM

[T11A0] 2-7

11. Diagnostics Chart with Trouble Code for Except 2200 cc California Spec. Vehicles

DTC No.	Item	Index
P0304	Cylinder 4 misfire detected	<Ref. to 2-7 [T11AA0].>
P0325	Knock sensor circuit high input	<Ref. to 2-7 [T11AB0].>
P0335	Crankshaft position sensor circuit malfunction	<Ref. to 2-7 [T11AC0].>
P0336	Crankshaft position sensor circuit range/performance problem	<Ref. to 2-7 [T11AD0].>
P0340	Camshaft position sensor circuit malfunction	<Ref. to 2-7 [T11AE0].>
P0341	Camshaft position sensor circuit range/performance problem	<Ref. to 2-7 [T11AF0].>
P0420	Catalyst system efficiency below threshold	<Ref. to 2-7 [T11AG0].>
P0440	Evaporative emission control system malfunction	<Ref. to 2-7 [T11AH0].>
P0443	Evaporative emission control system purge control valve circuit low input	<Ref. to 2-7 [T11AI0].>
P0446	Evaporative emission control system vent control low input	<Ref. to 2-7 [T11AJ0].>
P0451	Evaporative emission control system pressure sensor range/performance problem	<Ref. to 2-7 [T11AK0].>
P0452	Evaporative emission control system pressure sensor low input	<Ref. to 2-7 [T11AL0].>
P0453	Evaporative emission control system pressure sensor high input	<Ref. to 2-7 [T11AM0].>
P0461	Fuel level sensor circuit range/performance problem	<Ref. to 2-7 [T11AN0].>
P0462	Fuel level sensor circuit low input	<Ref. to 2-7 [T11AO0].>
P0463	Fuel level sensor circuit high input	<Ref. to 2-7 [T11AP0].>
P0480	Cooling fan relay 1 circuit low input	<Ref. to 2-7 [T11AQ0].>
P0483	Cooling fan function problem	<Ref. to 2-7 [T11AR0].>
P0500	Vehicle speed sensor malfunction	<Ref. to 2-7 [T11AS0].>
P0506	Idle control system RPM lower than expected	<Ref. to 2-7 [T11AT0].>
P0507	Idle control system RPM higher than expected	<Ref. to 2-7 [T11AU0].>
P0601	Internal control module memory check sum error	<Ref. to 2-7 [T11AV0].>
P0703	Brake switch input malfunction	<Ref. to 2-7 [T11AW0].>
P0705	Transmission range sensor circuit malfunction	<Ref. to 2-7 [T11AX0].>
P0710	Transmission fluid temperature sensor circuit malfunction	<Ref. to 2-7 [T11AY0].>
P0715	Torque converter turbine speed sensor circuit malfunction	<Ref. to 2-7 [T11AZ0].>
P0720	Output speed sensor (vehicle speed sensor 2) circuit malfunction	<Ref. to 2-7 [T11BA0].>

2-7 [T11A0]

ON-BOARD DIAGNOSTICS II SYSTEM

11. Diagnostics Chart with Trouble Code for Except 2200 cc California Spec. Vehicles

DTC No.	Item	Index
P0725	Engine speed input circuit malfunction	<Ref. to 2-7 [T11BB0].>
P0731	Gear 1 incorrect ratio	<Ref. to 2-7 [T11BC0].>
P0732	Gear 2 incorrect ratio	<Ref. to 2-7 [T11BD0].>
P0733	Gear 3 incorrect ratio	<Ref. to 2-7 [T11BE0].>
P0734	Gear 4 incorrect ratio	<Ref. to 2-7 [T11BF0].>
P0740	Torque converter clutch system malfunction	<Ref. to 2-7 [T11BG0].>
P0743	Torque converter clutch system (Solenoid B) electrical	<Ref. to 2-7 [T11BH0].>
P0748	Pressure control solenoid (Duty solenoid A) electrical	<Ref. to 2-7 [T11BI0].>
P0753	Shift solenoid A (Shift solenoid 1) electrical	<Ref. to 2-7 [T11BJ0].>
P0758	Shift solenoid B (Shift solenoid 2) electrical	<Ref. to 2-7 [T11BK0].>
P1100	Starter switch circuit low input	<Ref. to 2-7 [T11BL0].>
P1101	Neutral position switch circuit low input [MT vehicles]	<Ref. to 2-7 [T11BM0].>
P1101	Neutral position switch circuit high input [AT vehicles]	<Ref. to 2-7 [T11BN0].>
P1102	Pressure sources switching solenoid valve circuit low input	<Ref. to 2-7 [T11BO0].>
P1103	Engine torque control signal 1 circuit malfunction	<Ref. to 2-7 [T11BP0].>
P1106	Engine torque control signal 2 circuit malfunction	<Ref. to 2-7 [T11BQ0].>
P1115	Engine torque control cut signal circuit high input	<Ref. to 2-7 [T11BR0].>
P1116	Engine torque control cut signal circuit low input	<Ref. to 2-7 [T11BS0].>
P1120	Starter switch circuit high input	<Ref. to 2-7 [T11BT0].>
P1121	Neutral position switch circuit high input [MT vehicles]	<Ref. to 2-7 [T11BU0].>
P1121	Neutral position switch circuit low input [AT vehicles]	<Ref. to 2-7 [T11BV0].>
P1122	Pressure sources switching solenoid valve circuit high input	<Ref. to 2-7 [T11BW0].>
P1141	Mass air flow sensor circuit range/performance problem (low input)	<Ref. to 2-7 [T11BX0].>
P1142	Throttle position sensor circuit range/performance problem (low input)	<Ref. to 2-7 [T11BY0].>
P1143	Pressure sensor circuit range/performance problem (low input)	<Ref. to 2-7 [T11BZ0].>
P1144	Pressure sensor circuit range/performance problem (high input)	<Ref. to 2-7 [T11CA0].>
P1150	Front oxygen sensor heater circuit high input	<Ref. to 2-7 [T11CB0].>

ON-BOARD DIAGNOSTICS II SYSTEM

[T11A0] 2-7

11. Diagnostics Chart with Trouble Code for Except 2200 cc California Spec. Vehicles

DTC No.	Item	Index
P1151	Rear oxygen sensor heater circuit high input	<Ref. to 2-7 [T11CC0].>
P1325	Knock sensor circuit low input	<Ref. to 2-7 [T11CD0].>
P1400	Fuel tank pressure control solenoid valve circuit low input	<Ref. to 2-7 [T11CE0].>
P1420	Fuel tank pressure control solenoid valve circuit high input	<Ref. to 2-7 [T11CF0].>
P1422	Evaporative emission control system purge control valve circuit high input	<Ref. to 2-7 [T11CG0].>
P1423	Evaporative emission control system vent control high input	<Ref. to 2-7 [T11CH0].>
P1442	Fuel level sensor circuit range/performance problem 2	<Ref. to 2-7 [T11CI0].>
P1443	Evaporative emission control system vent control function problem	<Ref. to 2-7 [T11CJ0].>
P1507	Idle control system malfunction (fail-safe)	<Ref. to 2-7 [T11CK0].>
P1510	Idle air control solenoid valve signal 1 circuit low input	<Ref. to 2-7 [T11CL0].>
P1511	Idle air control solenoid valve signal 1 circuit high input	<Ref. to 2-7 [T11CM0].>
P1512	Idle air control solenoid valve signal 2 circuit low input	<Ref. to 2-7 [T11CN0].>
P1513	Idle air control solenoid valve signal 2 circuit high input	<Ref. to 2-7 [T11CO0].>
P1514	Idle air control solenoid valve signal 3 circuit low input	<Ref. to 2-7 [T11CP0].>
P1515	Idle air control solenoid valve signal 3 circuit high input	<Ref. to 2-7 [T11CQ0].>
P1516	Idle air control solenoid valve signal 4 circuit low input	<Ref. to 2-7 [T11CR0].>
P1517	Idle air control solenoid valve signal 4 circuit high input	<Ref. to 2-7 [T11CS0].>
P1520	Cooling fan relay 1 circuit high input	<Ref. to 2-7 [T11CT0].>
P1540	Vehicle speed sensor malfunction 2	<Ref. to 2-7 [T11CU0].>
P1560	Back-up voltage circuit malfunction	<Ref. to 2-7 [T11CV0].>
P1700	Throttle position sensor circuit malfunction for automatic transmission	<Ref. to 2-7 [T11CW0].>
P1701	Cruise control set signal circuit malfunction for automatic transmission	<Ref. to 2-7 [T11CX0].>
P1702	Automatic transmission diagnosis input signal circuit low input	<Ref. to 2-7 [T11CY0].>
P1703	Low clutch timing control solenoid valve circuit malfunction	<Ref. to 2-7 [T11CZ0].>
P1704	2-4 brake timing control solenoid valve circuit malfunction	<Ref. to 2-7 [T11DA0].>
P1705	2-4 brake pressure control solenoid valve (Duty solenoid D) circuit malfunction	<Ref. to 2-7 [T11DB0].>
P1722	Automatic transmission diagnosis input signal circuit high input	<Ref. to 2-7 [T11DC0].>

2-7 [T11A0]**ON-BOARD DIAGNOSTICS II SYSTEM**11. Diagnostics Chart with Trouble Code for Except 2200 cc California Spec. Vehicles

DTC No.	Item	Index
P1742	Automatic transmission diagnosis input signal circuit malfunction	<Ref. to 2-7 [T11DD0].>

ON-BOARD DIAGNOSTICS II SYSTEM

[T11A0] 2-7

11. Diagnostics Chart with Trouble Code for Except 2200 cc California Spec. Vehicles

MEMO:

B: DTC P0101 — MASS AIR FLOW SENSOR CIRCUIT RANGE/PERFORMANCE PROBLEM (HIGH INPUT) —

- **DTC DETECTING CONDITION:**
 - Two consecutive driving cycles with fault
- **TROUBLE SYMPTOM:**
 - Erroneous idling
 - Engine stalls.
 - Poor driving performance

CAUTION:

After repair or replacement of faulty parts, conduct CLEAR MEMORY MODE <Ref. to 2-7 [T3D0].> and INSPECTION MODE <Ref. to 2-7 [T3E0].>

● **WIRING DIAGRAM:**

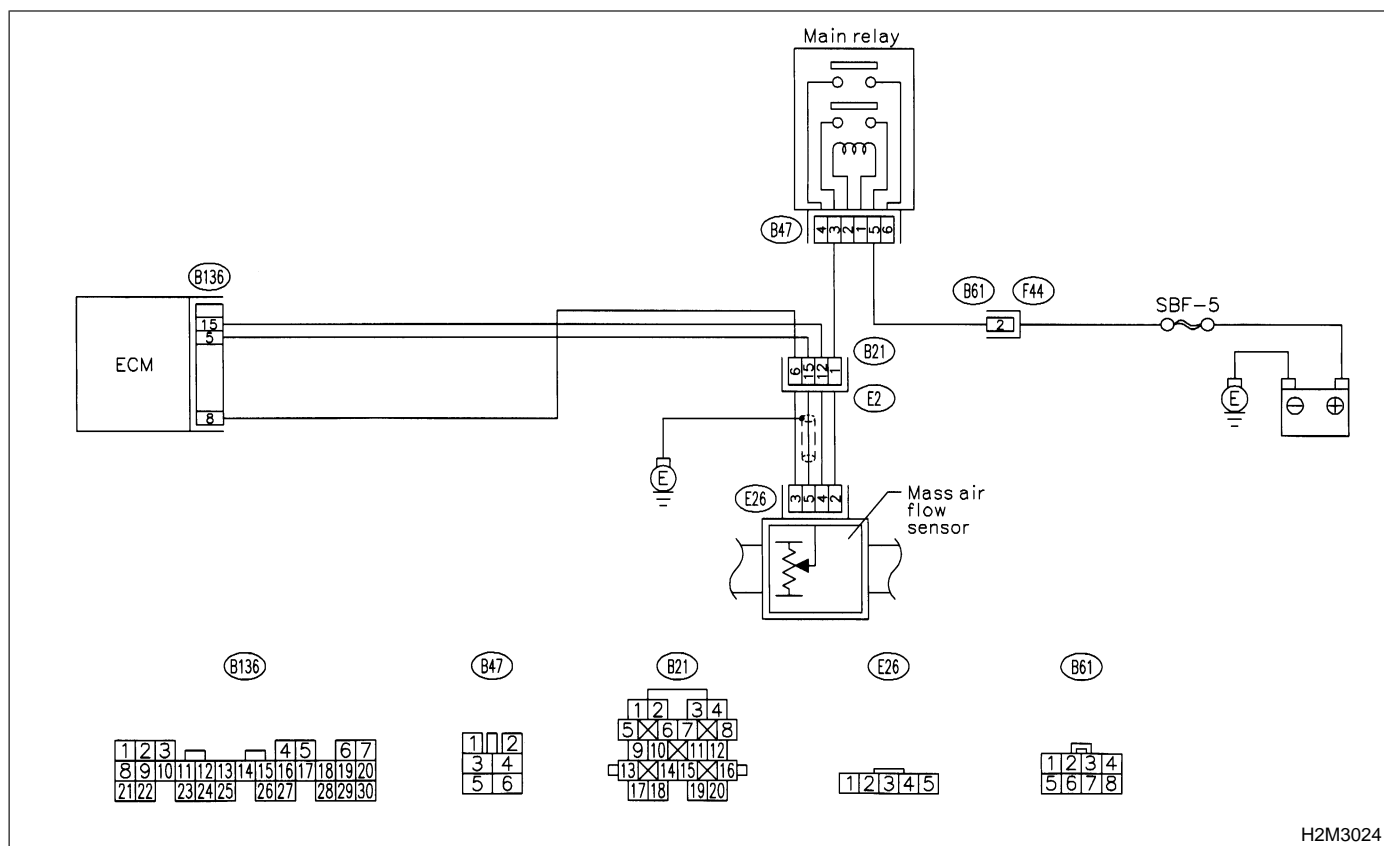

H2M3024

11B1 : CHECK ANY OTHER DTC ON DISPLAY.

- CHECK** : Does the Subaru Select Monitor or OBD-II general scan tool indicate DTC P0102 or P0103?
- YES** : Inspect DTC P0102 or P0103 using "11. Diagnostics Chart with Trouble Code for Except 2200 cc California Spec. Vehicles". <Ref. to 2-7 [T11A0].>

NOTE:

In this case, it is not necessary to inspect DTC P0101.

- NO** : Go to step 11B2.

11B2 : CHECK INPUT SIGNAL FOR ECM.

- 1) Turn ignition switch to ON.
- 2) Measure voltage between ECM connector and chassis ground while throttle valve is fully closed.

Connector & terminal

(B136) No. 17 (+) — Chassis ground (-):

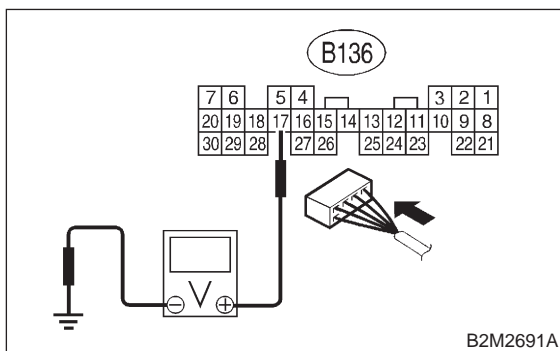

- CHECK** : *Is the voltage between 0.2 V and 1.0 V?*
- YES** : Go to step 11B3.
- NO** : Check throttle position sensor circuit. <Ref. to 2-7 [T11K0].>

11B3 : CHECK INPUT SIGNAL FOR ECM.

Measure voltage between ECM connector and chassis ground while throttle valve is fully opened.

Connector & terminal

(B136) No. 17 (+) — Chassis ground (-):

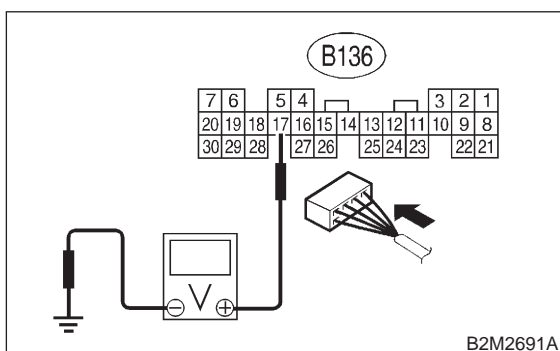

- CHECK** : *Is the voltage between 4.2 V and 4.7 V?*
- YES** : Replace mass air flow sensor. <Ref. to 2-7 [W2A0].>
- NO** : Check throttle position sensor circuit. <Ref. to 2-7 [T11K0].>

C: DTC P0102 — MASS AIR FLOW SENSOR CIRCUIT LOW INPUT —

- **DTC DETECTING CONDITION:**
 - Immediately at fault recognition

- **TROUBLE SYMPTOM:**
 - Erroneous idling
 - Engine stalls.
 - Poor driving performance

CAUTION:

After repair or replacement of faulty parts, conduct **CLEAR MEMORY MODE** <Ref. to 2-7 [T3D0].> and **INSPECTION MODE** <Ref. to 2-7 [T3E0].>

● **WIRING DIAGRAM:**

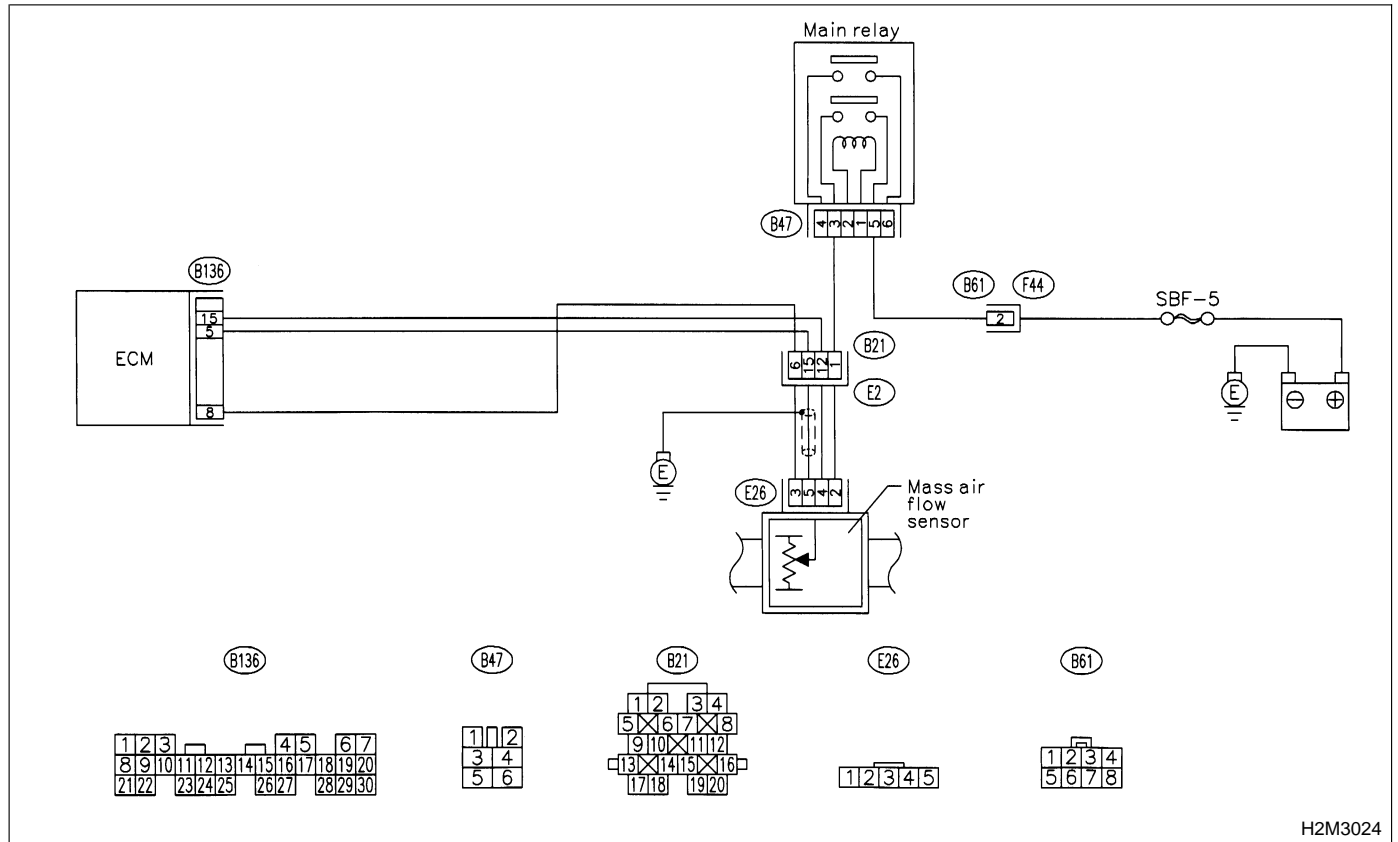

H2M3024

11C1 : CONNECT SUBARU SELECT MONITOR OR THE OBD-II GENERAL SCAN TOOL, AND READ DATA.

- 1) Turn ignition switch to OFF.
- 2) Connect Subaru Select Monitor or the OBD-II general scan tool to data link connector.

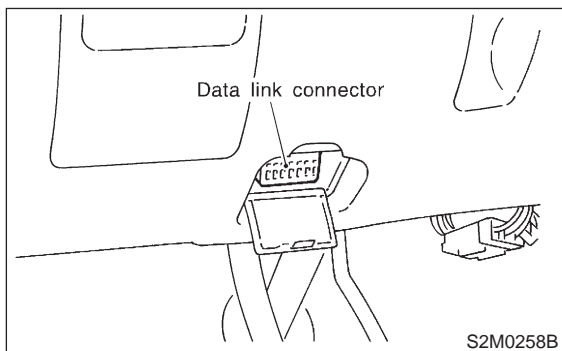

- 3) Turn ignition switch to ON and Subaru Select Monitor or the OBD-II general scan tool switch to ON.
- 4) Start engine.
- 5) Read data of mass air flow sensor signal using Subaru Select Monitor or OBD-II general scan tool.

NOTE:

- Subaru Select Monitor

For detailed operation procedure, refer to the "READ CURRENT DATA SHOWN ON DISPLAY FOR ENGINE". <Ref. to 2-7 [T3C4].>

- OBD-II general scan tool

For detailed operation procedure, refer to the OBD-II General Scan Tool Instruction Manual.

CHECK : *Is the value equal to or more than 0 g/sec (0 lb/min) or 0.3 V and equal to or less than 186 g/sec (25 lb/min) or 5.0 V?*

YES : Even if MIL lights up, the circuit has returned to a normal condition at this time. A temporary poor contact of the connector or harness may be the cause. Repair harness or connector in the mass air flow sensor.

NOTE:

In this case, repair the following:

- Open or ground short circuit in harness between mass air flow sensor and ECM connector
- Poor contact in mass air flow sensor or ECM connector

NO : Go to step **11C2**.

11C2 : CHECK INPUT SIGNAL FOR ECM.

Measure voltage between ECM connector and chassis ground while engine is idling.

Connector & terminal

(B136) No. 5 (+) — Chassis ground (-):

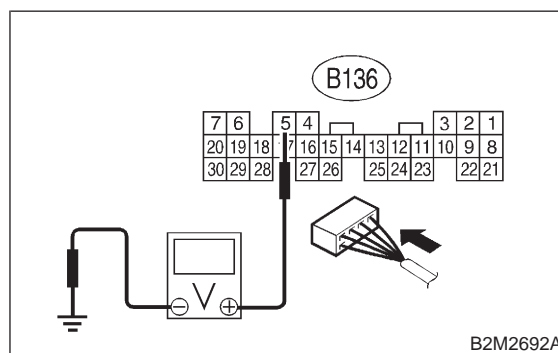

CHECK : *Is the voltage less than 0.3 V?*

YES : Go to step **11C4**.

NO : Go to step **11C3**.

11C3 : CHECK INPUT SIGNAL FOR ECM. (USING SUBARU SELECT MONITOR)

Measure voltage between ECM connector and chassis ground while engine is idling.

CHECK : *Does the voltage change more than 0.3 V by shaking harness and connector of ECM while monitoring the value with Subaru Select Monitor?*

YES : Repair poor contact in ECM connector.

NO : Contact with SOA service.

NOTE:

Inspection by DTM is required, because probable cause is deterioration of multiple parts.

2-7 [T11C4]

ON-BOARD DIAGNOSTICS II SYSTEM

11. Diagnostics Chart with Trouble Code for Except 2200 cc California Spec. Vehicles

11C4 : CHECK POWER SUPPLY TO MASS AIR FLOW SENSOR.

- 1) Turn ignition switch to OFF.
- 2) Disconnect connector from mass air flow sensor.
- 3) Turn ignition switch to ON.
- 4) Measure voltage between mass air flow sensor connector and engine ground.

Connector & terminal

(E26) No. 2 (+) — Engine ground (-):

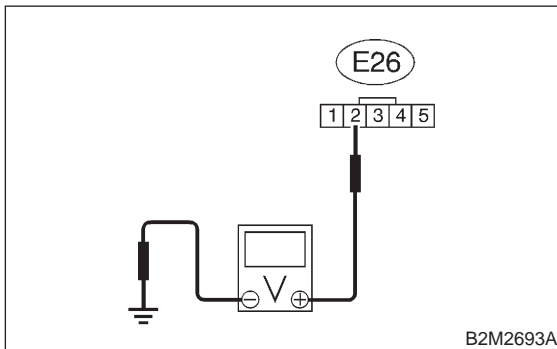

CHECK : *Is the voltage more than 10 V?*

YES : Go to step 11C5.

NO : Repair harness and connector.

NOTE:

In this case, repair the following:

- Open or ground short circuit in harness between main relay and mass air flow sensor connector
- Poor contact in main relay connector
- Poor contact in coupling connector (B21)

11C5 : CHECK POWER SUPPLY TO MASS AIR FLOW SENSOR.

Measure voltage between mass air flow sensor connector and engine ground.

Connector & terminal

(E26) No. 4 (+) — Engine ground (-):

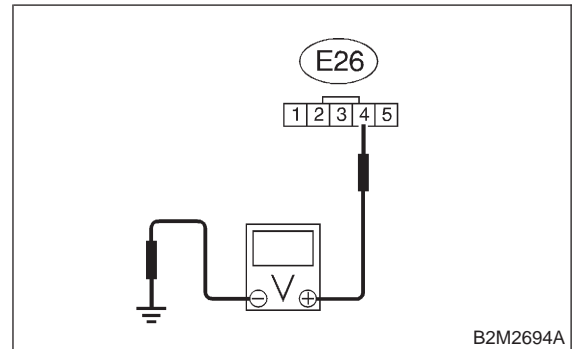

CHECK : *Is the voltage more than 4 V?*

YES : Go to step 11C6.

NO : Repair harness and connector.

NOTE:

In this case, repair the following:

- Open or ground short circuit in harness between ECM and mass air flow sensor connector
- Poor contact in ECM connector
- Poor contact in coupling connector (B21)

ON-BOARD DIAGNOSTICS II SYSTEM

[T11C7] 2-7

11. Diagnostics Chart with Trouble Code for Except 2200 cc California Spec. Vehicles

11C6 : CHECK HARNESS BETWEEN ECM AND MASS AIR FLOW SENSOR CONNECTOR.

- 1) Turn ignition switch to OFF.
- 2) Disconnect connector from ECM.
- 3) Measure resistance of harness between ECM and mass air flow sensor connector.

Connector & terminal

(B136) No. 5 — (E26) No. 5:

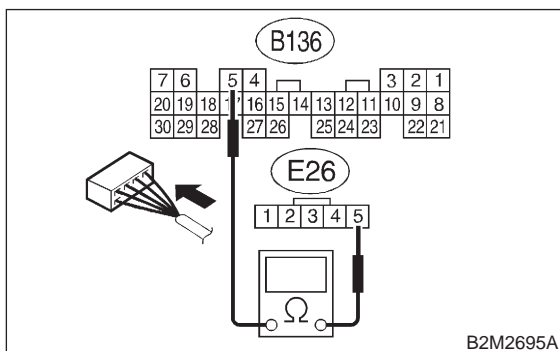

CHECK : Is the resistance less than 1 Ω?

YES : Go to step 11C7.

NO : Repair harness and connector.

NOTE:

In this case, repair the following:

- Open circuit in harness between ECM and mass air flow sensor connector
- Poor contact in mass air flow sensor connector
- Poor contact in ECM connector
- Poor contact in coupling connector (B21)

11C7 : CHECK HARNESS BETWEEN ECM AND MASS AIR FLOW SENSOR CONNECTOR.

Measure resistance of harness between ECM and mass air flow sensor connector.

Connector & terminal

(B136) No. 8 — (E26) No. 3:

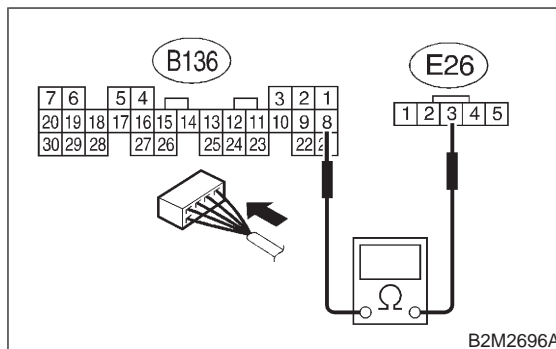

CHECK : Is the resistance less than 1 Ω?

YES : Go to step 11C8.

NO : Repair harness and connector.

NOTE:

In this case, repair the following:

- Open circuit in harness between ECM and mass air flow sensor connector
- Poor contact in mass air flow sensor connector
- Poor contact in ECM connector
- Poor contact in coupling connector (B21)

11C8 : CHECK HARNESS BETWEEN ECM AND MASS AIR FLOW SENSOR CONNECTOR.

Measure resistance of harness between ECM connector and chassis ground.

Connector & terminal

(B136) No. 5 — Chassis ground:

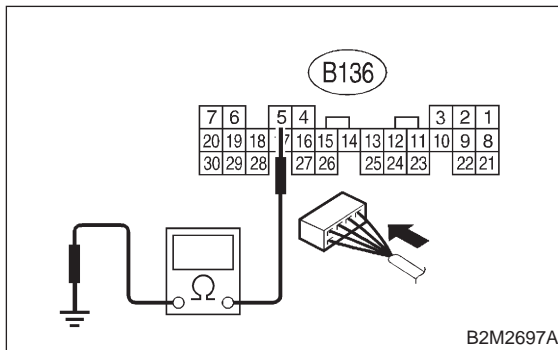

- CHECK** : *Is the resistance more than 1 MΩ?*
- YES** : Replace mass air flow sensor. <Ref. to 2-7 [W2A0].>
- NO** : Repair ground short circuit in harness between ECM and mass air flow sensor connector.

ON-BOARD DIAGNOSTICS II SYSTEM

[T11C8] 2-7

11. Diagnostics Chart with Trouble Code for Except 2200 cc California Spec. Vehicles

MEMO:

D: DTC P0103 — MASS AIR FLOW SENSOR CIRCUIT HIGH INPUT —

- **DTC DETECTING CONDITION:**
 - Immediately at fault recognition

- **TROUBLE SYMPTOM:**
 - Erroneous idling
 - Engine stalls.
 - Poor driving performance

CAUTION:

After repair or replacement of faulty parts, conduct **CLEAR MEMORY MODE** <Ref. to 2-7 [T3D0].> and **INSPECTION MODE** <Ref. to 2-7 [T3E0].>

● **WIRING DIAGRAM:**

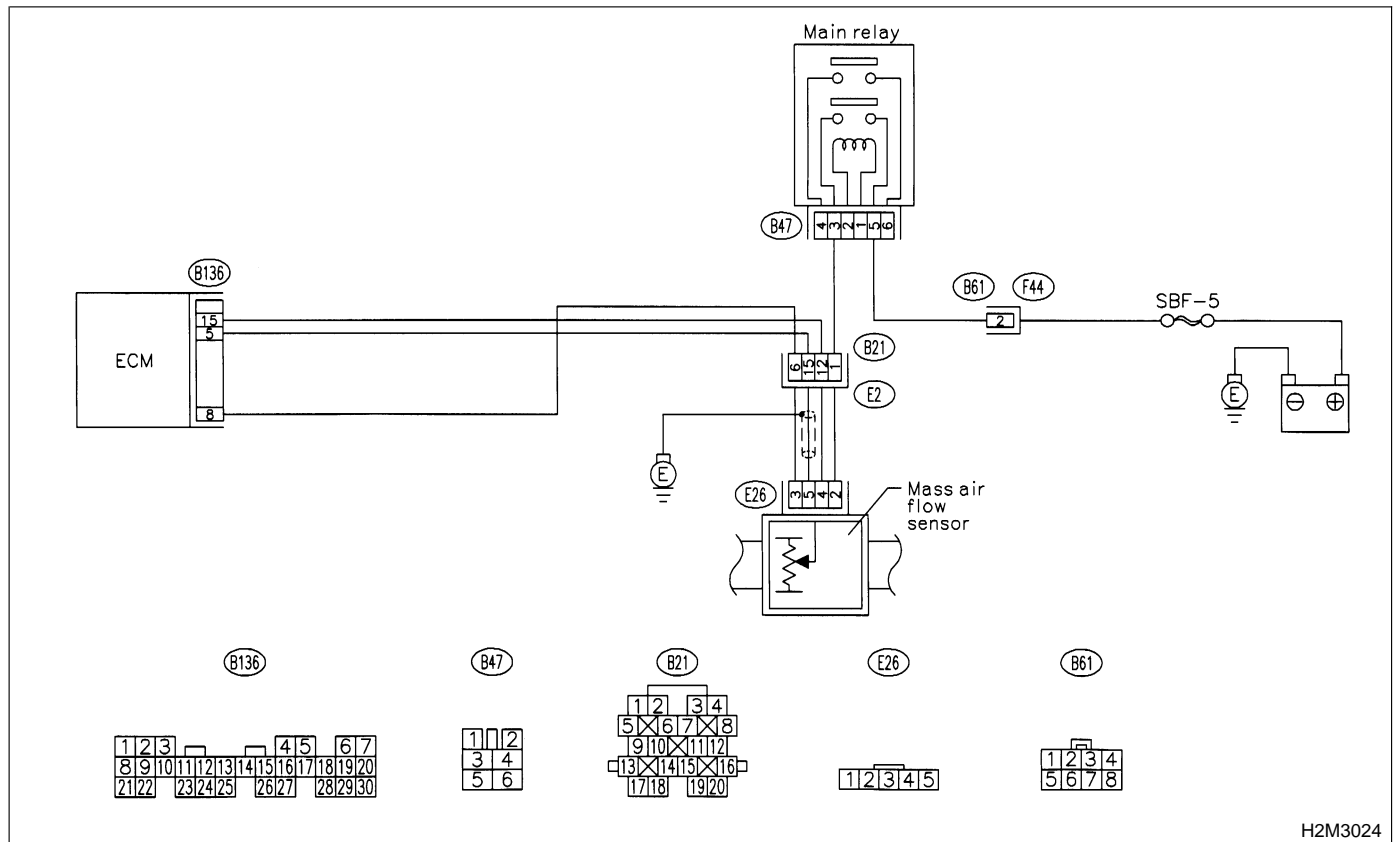

H2M3024

11D1 : CONNECT SUBARU SELECT MONITOR OR THE OBD-II GENERAL SCAN TOOL, AND READ DATA.

- 1) Turn ignition switch to OFF.
- 2) Connect Subaru Select Monitor or the OBD-II general scan tool to data link connector.

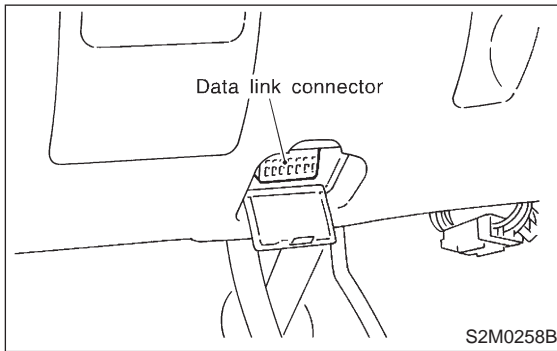

- 3) Turn ignition switch to ON and Subaru Select Monitor or the OBD-II general scan tool switch to ON.
- 4) Start engine.
- 5) Read data of mass air flow sensor signal using Subaru Select Monitor or OBD-II general scan tool.

NOTE:

- Subaru Select Monitor
For detailed operation procedure, refer to the "READ CURRENT DATA SHOWN ON DISPLAY FOR ENGINE". <Ref. to 2-7 [T3C4].>
- OBD-II general scan tool
For detailed operation procedures, refer to the OBD-II General Scan Tool Instruction Manual.

- CHECK** : *Is the value equal to or more than 0 g/sec (0 lb/min) or 0.3 V and equal to or less than 186 g/sec (25 lb/min) or 5.0 V?*
- YES** : Even if MIL lights up, the circuit has returned to a normal condition at this time.
- NO** : Go to step **11D2**.

11D2 : CHECK HARNESS BETWEEN ECM AND MASS AIR FLOW SENSOR CONNECTOR.

- 1) Turn ignition switch to OFF and Subaru Select Monitor or the OBD-II general scan tool switch to OFF.
- 2) Disconnect connector from mass air flow sensor.
- 3) Turn ignition switch to ON and Subaru Select Monitor or the OBD-II general scan tool switch to ON.
- 4) Read data of mass air flow sensor signal using Subaru Select Monitor or OBD-II general scan tool.

NOTE:

- Subaru Select Monitor
For detailed operation procedure, refer to the "READ CURRENT DATA SHOWN ON DISPLAY FOR ENGINE". <Ref. to 2-7 [T3C4].>
- OBD-II general scan tool
For detailed operation procedures, refer to the OBD-II General Scan Tool Instruction Manual.

- CHECK** : *Is the value more than 186 g/sec (25 lb/min) or 5 V?*
- YES** : Repair battery short circuit in harness between mass air flow sensor and ECM connector. After repair, replace ECM. <Ref. to 2-7 [W15A0].>
- NO** : Replace mass air flow sensor. <Ref. to 2-7 [W2A0].>

E: DTC P0106 — PRESSURE SENSOR CIRCUIT RANGE/PERFORMANCE PROBLEM —

- **DTC DETECTING CONDITION:**
 - Two consecutive driving cycles with fault

CAUTION:

After repair or replacement of faulty parts, conduct **CLEAR MEMORY MODE** <Ref. to 2-7 [T3D0].> and **INSPECTION MODE** <Ref. to 2-7 [T3E0].>

● **WIRING DIAGRAM:**

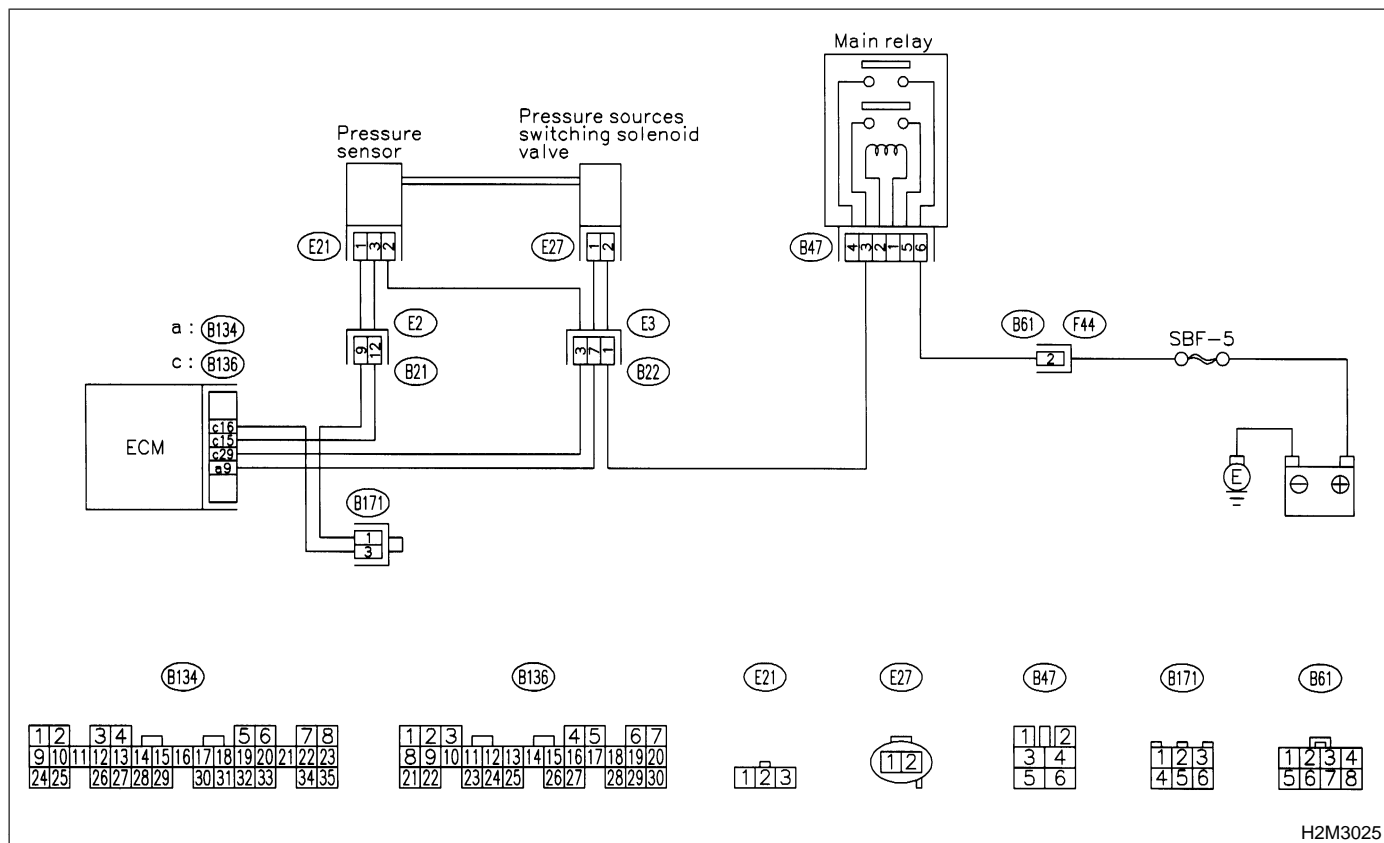

11E1 : CHECK ANY OTHER DTC ON DISPLAY.

NOTE:
In this case, it is not necessary to inspect DTC P0106.

- CHECK** : Does the Subaru Select Monitor or OBD-II general scan tool indicate DTC P0107, P0108, P1102 OR P1122?
- YES** : Inspect DTC P0107, P0108, P1102 OR P1122 using “11. Diagnostics Chart with Trouble Code for Except 2200 cc California Spec. Vehicles”. <Ref. to 2-7 [T11A0].>
- NO** : Go to step **11E2**.

11E2 : CHECK IDLE SWITCH SIGNAL.

- 1) Turn ignition switch to OFF.
- 2) Connect Subaru Select Monitor to data link connector.

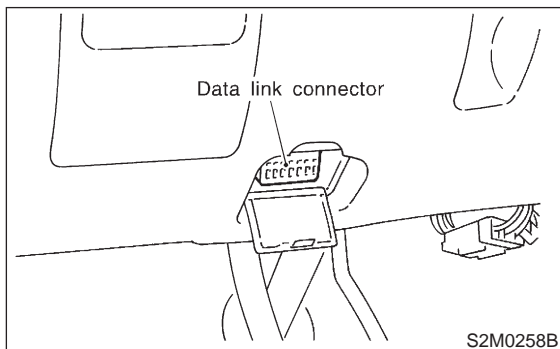

- 3) Turn ignition switch to ON and Subaru Select Monitor switch to ON.
- 4) Operate the LED operation mode for engine using Subaru Select Monitor.

NOTE:

- Subaru Select Monitor

For detailed operation procedure, refer to the "LED OPERATION MODE FOR ENGINE". <Ref. to 2-7 [T3C8].>

CHECK : **Does the LED of {Idle Switch Signal} come on?**

YES : Go to step 11E3.

NO : Check throttle position sensor circuit. <Ref. to 2-7 [T11K0].>

NOTE:

In this case, it is not necessary to inspect DTC P0106.

11E3 : CHECK DATA FOR CONTROL.

- 1) Turn ignition switch to OFF.
- 2) Connect Subaru Select Monitor or the OBD-II general scan tool to data link connector.

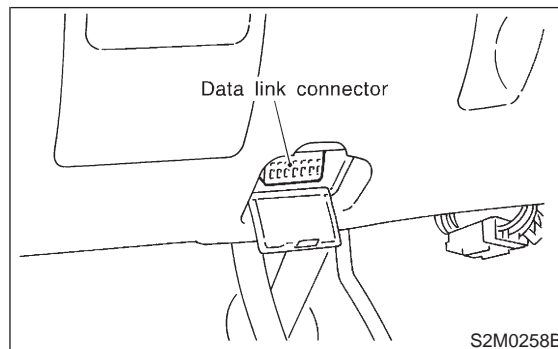

- 3) Turn ignition switch ON and Subaru Select Monitor or the OBD-II general scan tool switch ON.
- 4) Start engine.
- 5) Read data of intake manifold absolute pressure signal using Subaru Select Monitor or OBD-II general scan tool.

NOTE:

- Subaru Select Monitor

For detailed operation procedure, refer to the "READ CURRENT DATA SHOWN ON DISPLAY FOR ENGINE". <Ref. to 2-7 [T3C4].>

- OBD-II general scan tool

For detailed operation procedures, refer to the OBD-II General Scan Tool Instruction Manual.

CHECK : **Is the value more than 85 kPa (638 mmHg, 25.12 inHg)?**

YES : Go to step 11E6.

NO : Go to step 11E4.

11E4 : CHECK DATA FOR CONTROL.

Read data of atmospheric absolute pressure signal using Subaru Select Monitor or OBD-II general scan tool.

CHECK : **Is the value less than 32 kPa (240 mmHg, 9.45 inHg)?**

YES : Go to step 11E7.

NO : Go to step 11E5.

11E5 : CHECK DATA FOR CONTROL.

Read data of atmospheric absolute pressure signal using Subaru Select Monitor or OBD-II general scan tool.

- CHECK** : *Is the value more than 133 kPa (998 mmHg, 39.29 inHg)?*
- YES** : Replace pressure sensor. <Ref. to 2-7 [W11A0].>
- NO** : Repair poor contact in pressure sensor connector, pressure sources switching solenoid valve connector, and ECM connector.

11E6 : CHECK VACUUM HOSES.

Check the following items.

- Disconnection of the vacuum hose from pressure sources switching solenoid valve to intake manifold
- Holes in the vacuum hose between pressure sources switching solenoid valve to intake manifold
- Clogging of the vacuum hose between pressure sources switching solenoid valve to intake manifold
- Disconnection of the vacuum hose from pressure sensor to pressure sources switching solenoid valve
- Holes in the vacuum hose between pressure sensor and pressure sources switching solenoid valve
- Clogging of the vacuum hose between pressure sensor and pressure sources switching solenoid valve
- Clogging of the filter

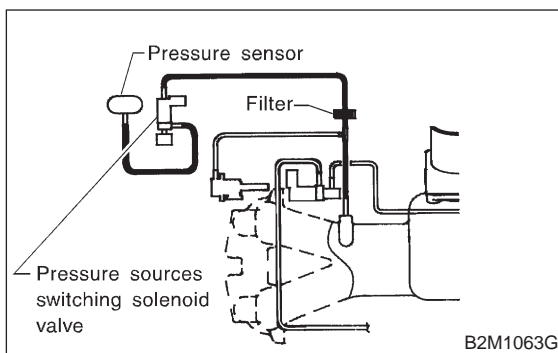

- CHECK** : *Is there a fault in vacuum hose?*
- YES** : Repair or replace hoses or filter.
- NO** : Go to step 11E7.

11E7 : CHECK PRESSURE SOURCES SWITCHING SOLENOID VALVE.

- 1) Turn ignition switch to OFF.
- 2) Connect test mode connector.

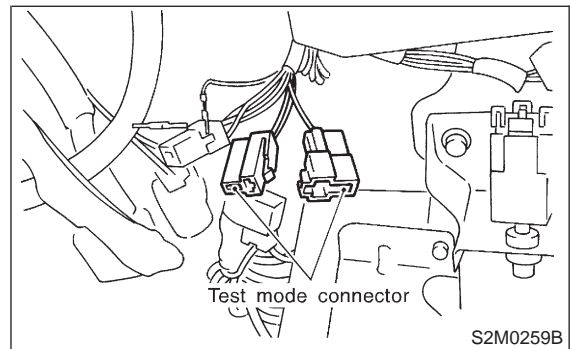

- 3) Turn ignition switch to ON.

NOTE:

Pressure sources switching solenoid valve operation check can also be executed using Subaru Select Monitor. For the procedure, refer to the "COMPULSORY VALVE OPERATION CHECK MODE". <Ref. to 2-7 [T3F0].>

- CHECK** : *Does pressure sources switching solenoid valve produce operating sound? (ON ⇔ OFF each 1.5 sec.)*
- YES** : Replace pressure sensor. <Ref. to 2-7 [W11A0].>
- NO** : Replace pressure sources switching solenoid valve. <Ref. to 2-7 [W13A0].>

ON-BOARD DIAGNOSTICS II SYSTEM

[T11E7] 2-7

11. Diagnostics Chart with Trouble Code for Except 2200 cc California Spec. Vehicles

MEMO:

F: DTC P0107 — PRESSURE SENSOR CIRCUIT LOW INPUT —

- DTC DETECTING CONDITION:
 - Immediately at fault recognition

CAUTION:

After repair or replacement of faulty parts, conduct CLEAR MEMORY MODE <Ref. to 2-7 [T3D0].> and INSPECTION MODE <Ref. to 2-7 [T3E0].>

● WIRING DIAGRAM:

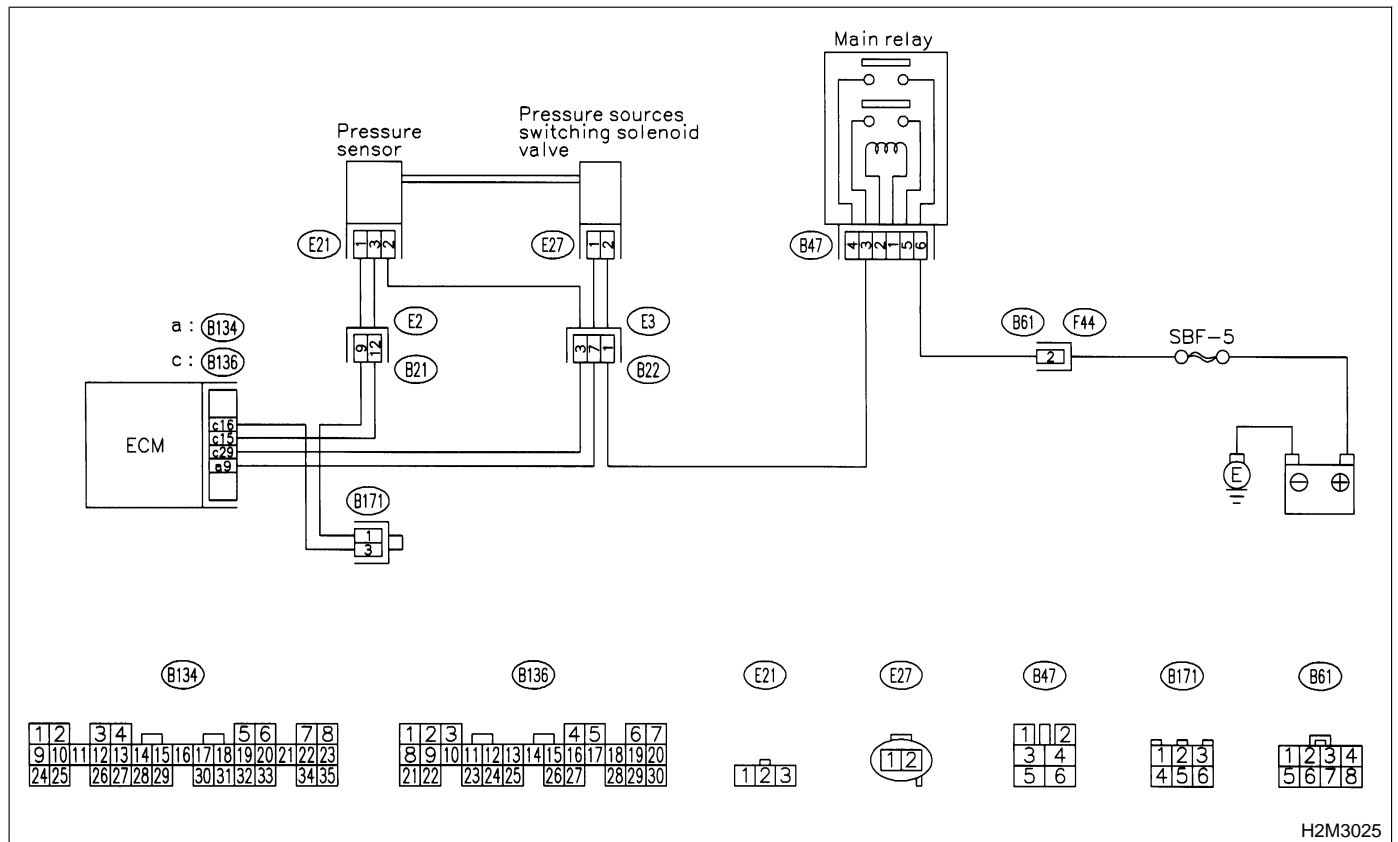

H2M3025

11F1 : CONNECT SUBARU SELECT MONITOR OR THE OBD-II GENERAL SCAN TOOL, AND READ DATA.

- 1) Turn ignition switch to OFF.
- 2) Connect Subaru Select Monitor or the OBD-II general scan tool to data link connector.

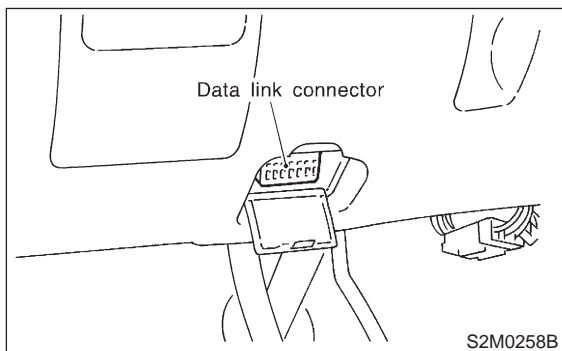

- 3) Turn ignition switch to ON and Subaru Select Monitor or the OBD-II general scan tool switch to ON.
- 4) Start engine.
- 5) Read the data of intake manifold absolute pressure signal using Subaru Select Monitor or OBD-II general scan tool.

NOTE:

- Subaru Select Monitor

For detailed operation procedure, refer to the "READ CURRENT DATA SHOWN ON DISPLAY FOR ENGINE". <Ref. to 2-7 [T3C4].>

- OBD-II general scan tool

For detailed operation procedures, refer to the OBD-II General Scan Tool Instruction Manual.

CHECK : *Is the value less than 0 kPa (0 mmHg, 0 inHg)?*

YES : Go to step 11F3.

NO : Go to step 11F2.

11F2 : CHECK POOR CONTACT.

Check poor contact in ECM and pressure sensor connector. <Ref. to FOREWORD [T3C1].>

CHECK : *Is there poor contact in ECM or pressure sensor connector?*

YES : Repair poor contact in ECM or pressure sensor connector.

NO : Even if MIL lights up, the circuit has returned to a normal condition at this time.

11F3 : CHECK INPUT SIGNAL FOR ECM.

Measure voltage between ECM connector and chassis ground.

Connector & terminal

(B136) No. 15 (+) — Chassis ground (-):

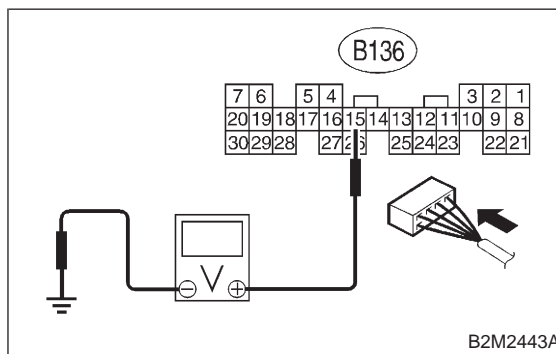

CHECK : *Is the voltage more than 4.5 V?*

YES : Go to step 11F5.

NO : Go to step 11F4.

11F4 : CHECK INPUT SIGNAL FOR ECM.

Measure voltage between ECM connector and chassis ground.

Connector & terminal

(B136) No. 15 (+) — Chassis ground (-):

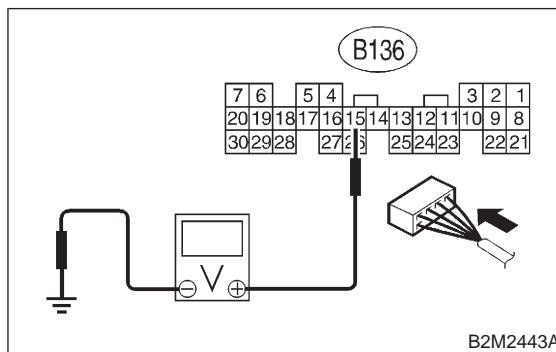

CHECK : *Does the voltage change more than 4.5 V by shaking harness and connector of ECM while monitoring the value with voltage meter?*

YES : Repair poor contact in ECM connector.

NO : Contact with SOA service.

NOTE:

Inspection by DTM is required, because probable cause is deterioration of multiple parts.

2-7 [T11F5]

ON-BOARD DIAGNOSTICS II SYSTEM

11. Diagnostics Chart with Trouble Code for Except 2200 cc California Spec. Vehicles

11F5 : CHECK INPUT SIGNAL FOR ECM.

Measure voltage between ECM and chassis ground.

Connector & terminal

(B136) No. 29 (+) — Chassis ground (-):

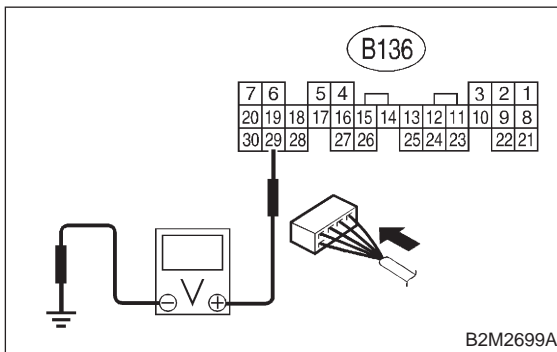

- CHECK** : Is the voltage less than 0.2 V?
YES : Go to step 11F7.
NO : Go to step 11F6.

11F6 : CHECK INPUT SIGNAL FOR ECM. (USING SUBARU SELECT MONITOR.)

Read data of atmospheric absolute pressure signal using Subaru Select Monitor.

NOTE:

- Subaru Select Monitor

For detailed operation procedure, refer to the "READ CURRENT DATA SHOWN ON DISPLAY FOR ENGINE". <Ref. to 2-7 [T3C4].>

- CHECK** : Does the value change more than 0 kPa (0 mmHg, 0 inHg) by shaking harness and connector of ECM while monitoring the value with Subaru select monitor?
YES : Repair poor contact in ECM connector.
NO : Go to step 11F7.

11F7 : CHECK HARNESS BETWEEN ECM AND PRESSURE SENSOR CONNECTOR.

- Turn ignition switch to OFF.
- Disconnect connector from pressure sensor.
- Turn ignition switch to ON.
- Measure voltage between pressure sensor connector and engine ground.

Connector & terminal

(E21) No. 3 (+) — Engine ground (-):

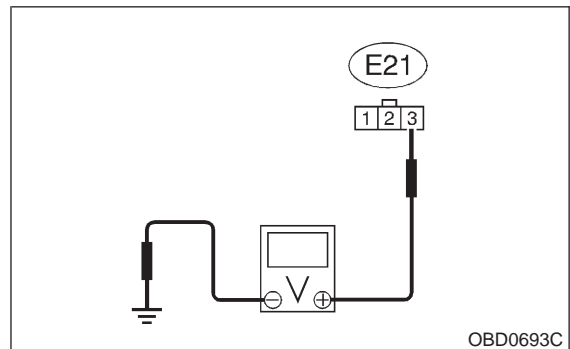

- CHECK** : Is the voltage more than 4.5 V?
YES : Go to step 11F8.
NO : Repair harness and connector.

NOTE:

In this case, repair the following:

- Open circuit in harness between ECM and pressure sensor connector
- Poor contact in coupling connector (B21)

11F8 : CHECK HARNESS BETWEEN ECM AND PRESSURE SENSOR CONNECTOR.

- 1) Turn ignition switch to OFF.
- 2) Disconnect connector from ECM.
- 3) Measure resistance of harness between ECM and pressure sensor connector.

Connector & terminal

(B136) No. 16 — (E21) No. 1:

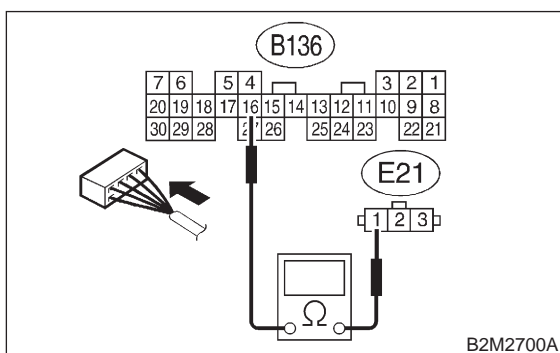

- CHECK** : *Is the resistance less than 1 Ω?*
- YES** : Go to step 11F9.
- NO** : Repair harness and connector.

NOTE:

In this case, repair the following:

- Open circuit in harness between ECM and pressure sensor connector
- Poor contact in coupling connector (B21)

11F9 : CHECK HARNESS BETWEEN ECM AND PRESSURE SENSOR CONNECTOR.

Measure resistance of harness between pressure sensor connector and engine ground.

Connector & terminal

(E21) No. 2 — Engine ground:

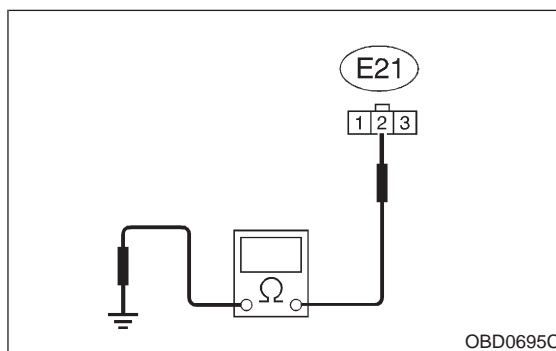

- CHECK** : *Is the resistance more than 500 kΩ?*
- YES** : Go to step 11F10.
- NO** : Repair ground short circuit in harness between ECM and pressure sensor connector.

11F10 : CHECK POOR CONTACT.

Check poor contact in pressure sensor connector. <Ref. to FOREWORD [T3C1].>

- CHECK** : *Is there poor contact in pressure sensor connector?*
- YES** : Repair poor contact in pressure sensor connector.
- NO** : Replace pressure sensor. <Ref. to 2-7 [W11A0].>

G: DTC P0108 — PRESSURE SENSOR CIRCUIT HIGH INPUT —

- DTC DETECTING CONDITION:
 - Immediately at fault recognition

CAUTION:

After repair or replacement of faulty parts, conduct CLEAR MEMORY MODE <Ref. to 2-7 [T3D0].> and INSPECTION MODE <Ref. to 2-7 [T3E0].>

● WIRING DIAGRAM:

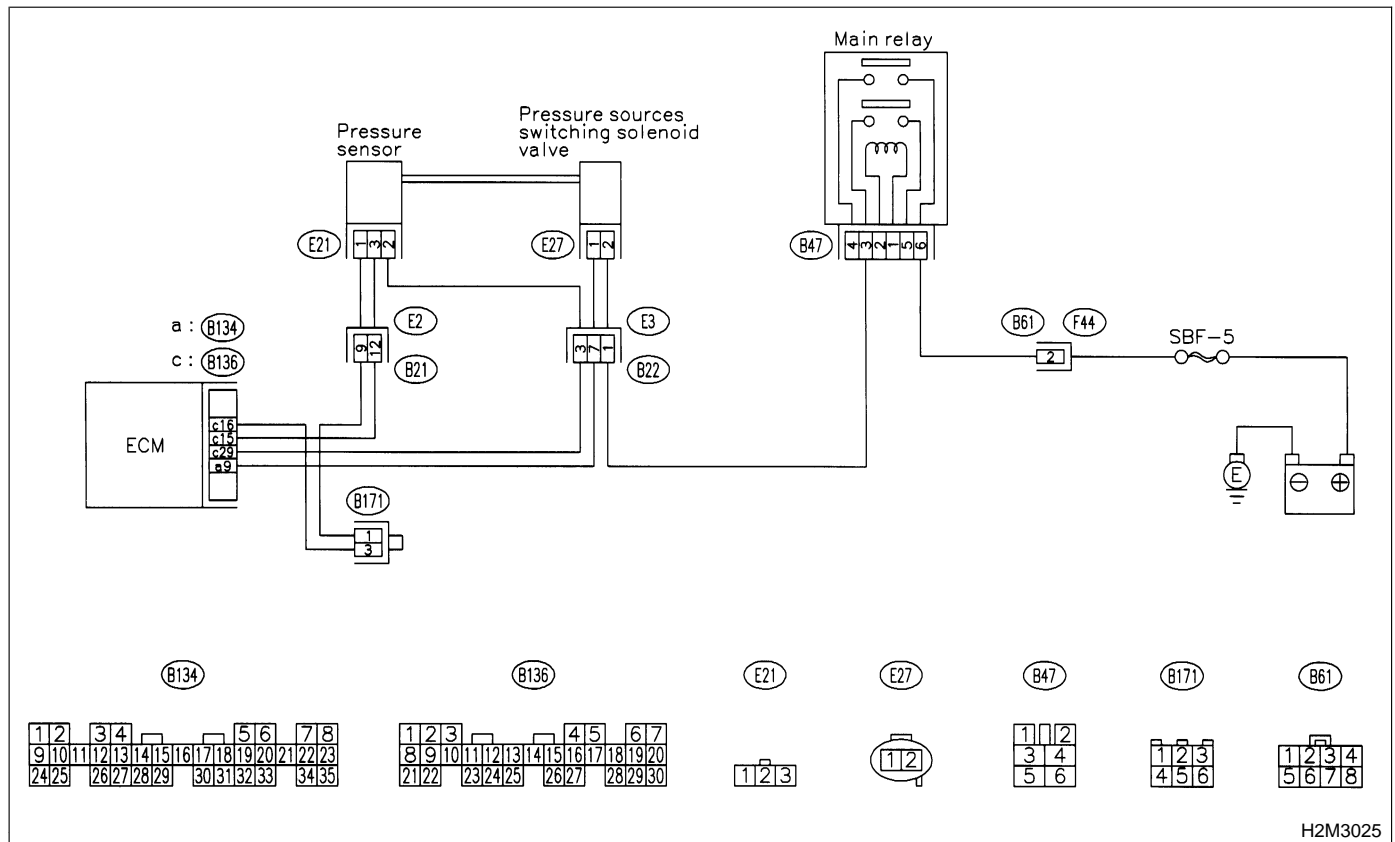

H2M3025

11G1 : CONNECT SUBARU SELECT MONITOR OR THE OBD-II GENERAL SCAN TOOL, AND READ DATA.

- 1) Turn ignition switch to OFF.
- 2) Connect Subaru Select Monitor or the OBD-II general scan tool to data link connector.

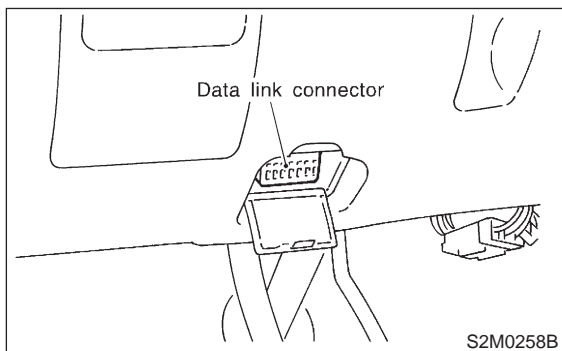

- 3) Turn ignition switch to ON and Subaru Select Monitor or the OBD-II general scan tool switch to ON.
- 4) Start engine.
- 5) Read the data of intake manifold absolute pressure signal using Subaru Select Monitor or OBD-II general scan tool.

NOTE:

- Subaru Select Monitor

For detailed operation procedure, refer to the "READ CURRENT DATA SHOWN ON DISPLAY FOR ENGINE". <Ref. to 2-7 [T3C4].>

- OBD-II general scan tool

For detailed operation procedures, refer to the OBD-II General Scan Tool Instruction Manual.

CHECK : *Is the value more than 140 kPa (1,050 mmHg, 41.34 inHg)?*

YES : Go to step 11G10.

NO : Go to step 11G2.

11G2 : CHECK INPUT SIGNAL FOR ECM.

Measure voltage between ECM connector and chassis ground.

Connector & terminal

(B136) No. 15 (+) — Chassis ground (-):

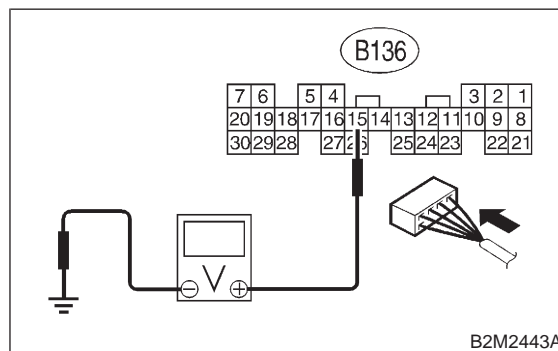

CHECK : *Is the voltage more than 4.5 V?*

YES : Go to step 11G4.

NO : Go to step 11G3.

11G3 : CHECK INPUT SIGNAL FOR ECM.

Measure voltage between ECM connector and chassis ground.

Connector & terminal

(B136) No. 15 (+) — Chassis ground (-):

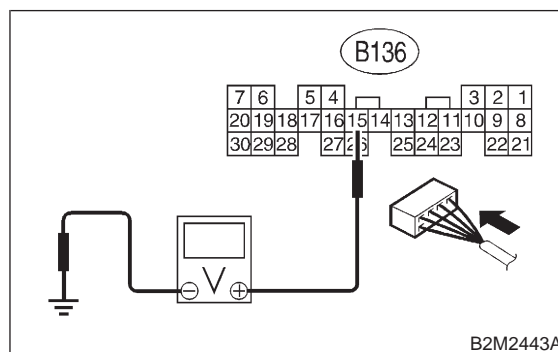

CHECK : *Does the voltage change more than 4.5 V by shaking harness and connector of ECM while monitoring the value with voltage meter?*

YES : Repair poor contact in ECM connector.

NO : Contact with SOA service.

NOTE:

Inspection by DTM is required, because probable cause is deterioration of multiple parts.

2-7 [T11G4]

ON-BOARD DIAGNOSTICS II SYSTEM

11. Diagnostics Chart with Trouble Code for Except 2200 cc California Spec. Vehicles

11G4 : CHECK INPUT SIGNAL FOR ECM.

Measure voltage between ECM connector and chassis ground.

Connector & terminal
(B136) No. 29 (+) — Chassis ground (-):

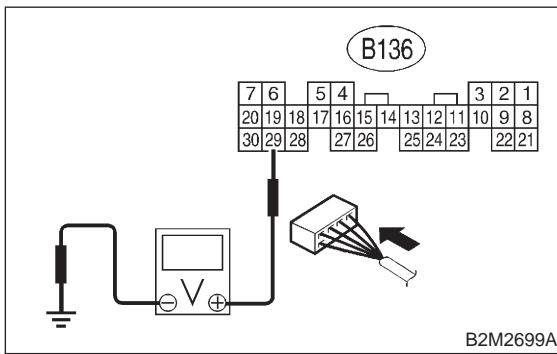

- CHECK** : Is the voltage less than 0.2 V?
YES : Go to step 11G6.
NO : Go to step 11G5.

11G5 : CHECK INPUT SIGNAL FOR ECM. (USING SUBARU SELECT MONITOR.)

Read data of atmospheric absolute pressure signal using Subaru Select Monitor.

NOTE:

- Subaru Select Monitor

For detailed operation procedure, refer to the "READ CURRENT DATA SHOWN ON DISPLAY FOR ENGINE". <Ref. to 2-7 [T3C4].>

- CHECK** : Does the value change more than 0 kPa (0 mmHg, 0 inHg) by shaking harness and connector of ECM while monitoring the value with Subaru select monitor?
YES : Repair poor contact in ECM connector.
NO : Go to step 11G6.

11G6 : CHECK HARNESS BETWEEN ECM AND PRESSURE SENSOR CONNECTOR.

- Turn ignition switch to OFF.
- Disconnect connector from pressure sensor.
- Turn ignition switch to ON.
- Measure voltage between pressure sensor connector and engine ground.

Connector & terminal
(E21) No. 3 (+) — Engine ground (-):

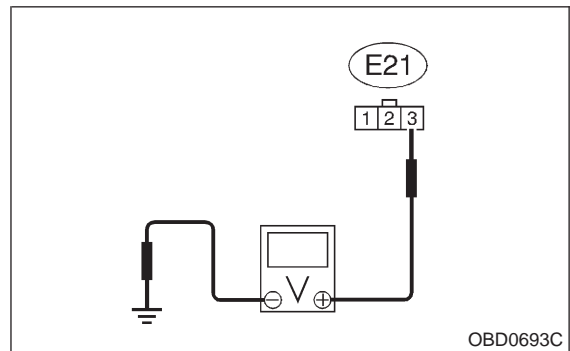

- CHECK** : Is the voltage more than 4.5 V?
YES : Go to step 11G7.
NO : Repair harness and connector.

NOTE:

In this case, repair the following:

- Open circuit in harness between ECM and pressure sensor connector
- Poor contact in coupling connector (B21)

11G7 : CHECK HARNESS BETWEEN ECM AND PRESSURE SENSOR CONNECTOR.

- 1) Turn ignition switch to OFF.
- 2) Disconnect connector from ECM.
- 3) Measure resistance of harness between ECM and pressure sensor connector.

Connector & terminal
(B136) No. 29 — (E21) No. 2:

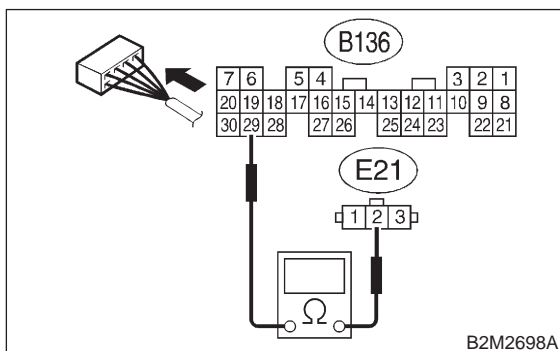

- CHECK** : *Is the resistance less than 1 Ω?*
YES : Go to step 11G8.
NO : Repair harness and connector.

NOTE:

In this case, repair the following:

- Open circuit in harness between ECM and pressure sensor connector
- Poor contact in coupling connector (B22)

11G8 : CHECK HARNESS BETWEEN ECM AND PRESSURE SENSOR CONNECTOR.

Measure resistance of harness between ECM and pressure sensor connector.

Connector & terminal
(B136) No. 16 — (E21) No. 1:

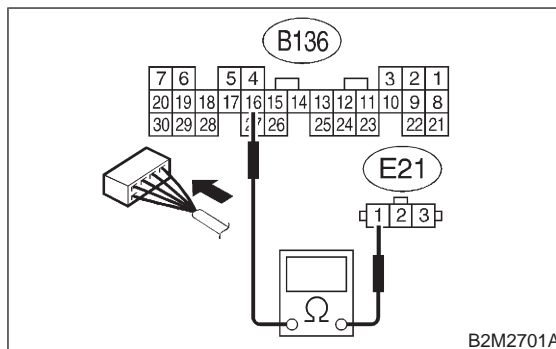

- CHECK** : *Is the resistance less than 1 Ω?*
YES : Go to step 11G9.
NO : Repair harness and connector.

NOTE:

In this case, repair the following:

- Open circuit in harness between ECM and pressure sensor connector
- Poor contact in coupling connector (B21)

11G9 : CHECK POOR CONTACT.

Check poor contact in pressure sensor connector.
<Ref. to FOREWORD [T3C1].>

- CHECK** : *Is there poor contact in pressure sensor connector?*
YES : Repair poor contact in pressure sensor connector.
NO : Replace pressure sensor. <Ref. to 2-7 [W11A0].>

11G10 : CHECK HARNESS BETWEEN ECM AND PRESSURE SENSOR CONNECTOR.

- 1) Turn ignition switch to OFF and Subaru Select Monitor or the OBD-II general scan tool switch to OFF.
- 2) Disconnect connector from pressure sensor.
- 3) Turn ignition switch to ON and Subaru Select Monitor or the OBD-II general scan tool switch to ON.
- 4) Read data of intake manifold absolute pressure signal using Subaru select monitor or OBD-II general scan tool.

NOTE:

- Subaru Select Monitor

For detailed operation procedure, refer to the "READ CURRENT DATA SHOWN ON DISPLAY FOR ENGINE". <Ref. to 2-7 [T3C4].>

- OBD-II general scan tool

For detailed operation procedures, refer to the OBD-II General Scan Tool Instruction Manual.

CHECK : ***Is the value more than 140 kPa (1,050 mmHg, 41.34 inHg)?***

YES : Repair battery short circuit in harness between ECM and pressure sensor connector.

NO : Replace pressure sensor. <Ref. to 2-7 [W11A0].>

ON-BOARD DIAGNOSTICS II SYSTEM

[T11G10] 2-7

11. Diagnostics Chart with Trouble Code for Except 2200 cc California Spec. Vehicles

MEMO:

H: DTC P0116 — ENGINE COOLANT TEMPERATURE SENSOR CIRCUIT LOW INPUT —

- **DTC DETECTING CONDITION:**
 - Immediately at fault recognition
- **TROUBLE SYMPTOM:**
 - Hard to start
 - Erroneous idling
 - Poor driving performance

CAUTION:

After repair or replacement of faulty parts, conduct CLEAR MEMORY MODE <Ref. to 2-7 [T3D0].> and INSPECTION MODE <Ref. to 2-7 [T3E0].>

● **WIRING DIAGRAM:**

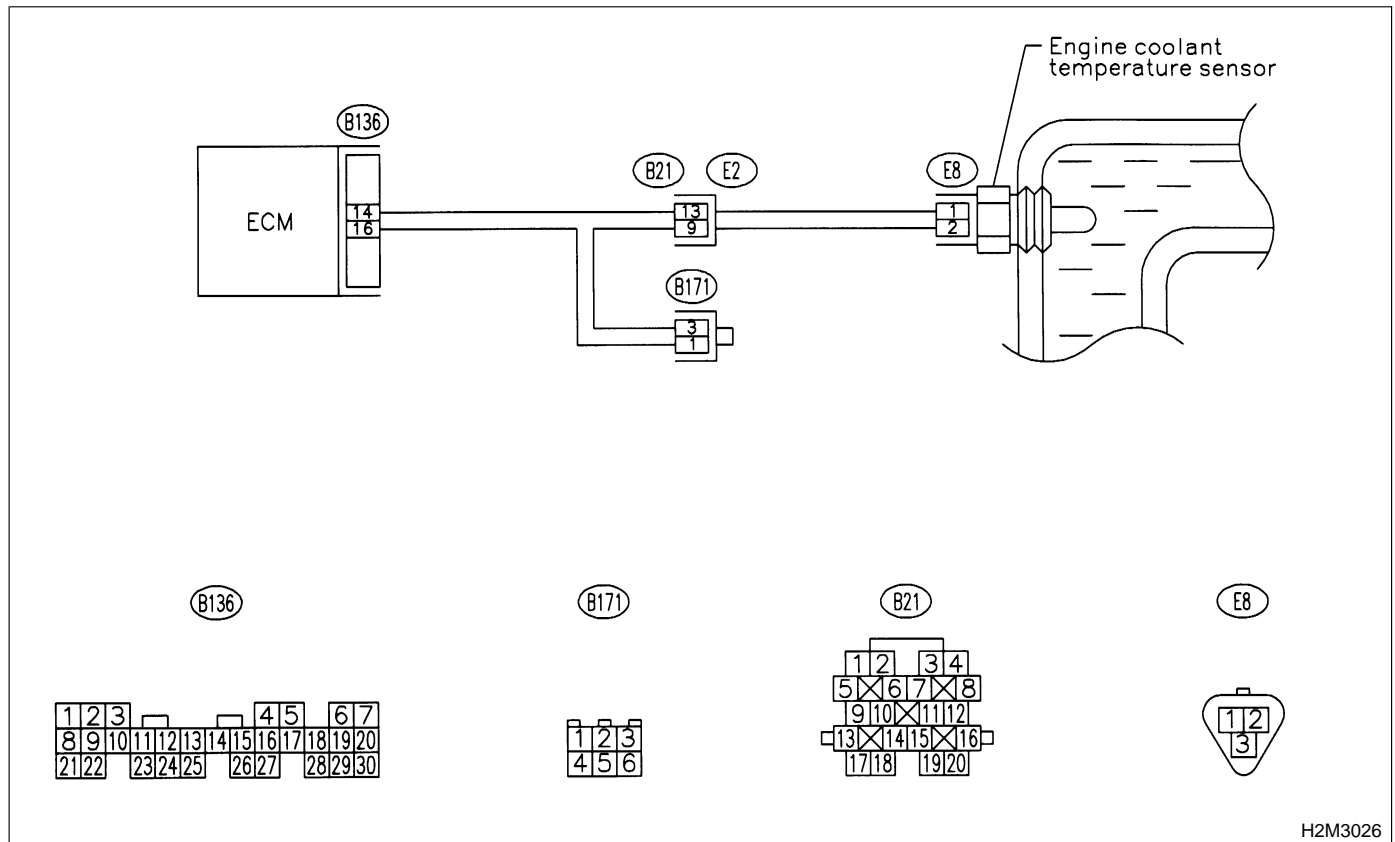

H2M3026

11H1 : CONNECT SUBARU SELECT MONITOR OR THE OBD-II GENERAL SCAN TOOL, AND READ DATA.

- 1) Turn ignition switch to OFF.
- 2) Connect Subaru Select Monitor or the OBD-II general scan tool to data link connector.

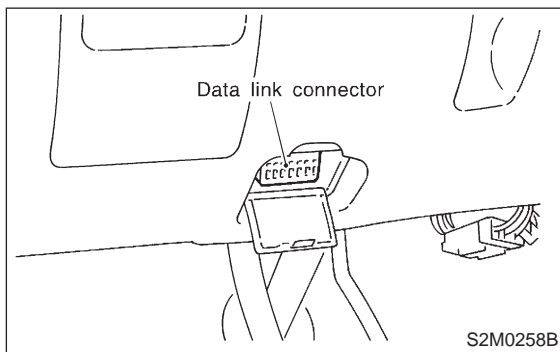

- 3) Turn ignition switch to ON and Subaru Select Monitor or OBD-II general scan tool switch to ON.
- 4) Start engine.
- 5) Read data of engine coolant temperature sensor signal using Subaru Select Monitor or OBD-II general scan tool.

NOTE:

- Subaru Select Monitor
For detailed operation procedure, refer to the "READ CURRENT DATA SHOWN ON DISPLAY FOR ENGINE". <Ref. to 2-7 [T3C4].>
- OBD-II general scan tool
For detailed operation procedures, refer to the OBD-II General Scan Tool Instruction Manual.

CHECK : *Is the value greater than 150°C (300°F)?*

YES : Go to step 11H2.

NO : Repair poor contact.

NOTE:

In this case, repair the following:

- Poor contact in engine coolant temperature sensor
- Poor contact in ECM
- Poor contact in coupling connector (B21)

11H2 : CHECK HARNESS BETWEEN ENGINE COOLANT TEMPERATURE SENSOR AND ECM CONNECTOR.

- 1) Turn ignition switch to OFF.
- 2) Remove air intake duct and air intake chamber assembly as a unit.

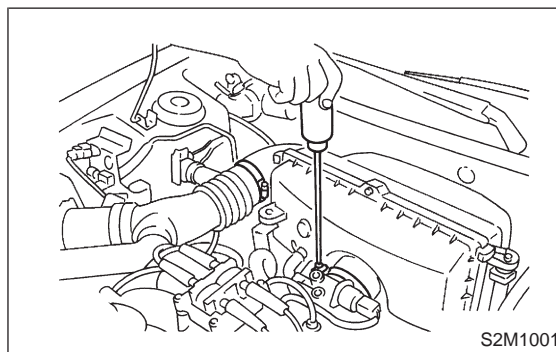

- 3) Remove engine harness connector bracket from cylinder block.

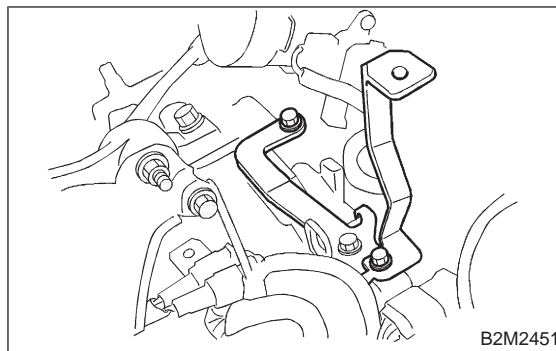

- 4) Remove blow-by hoses.



- 5) Disconnect connector from engine coolant temperature sensor.
- 6) Turn ignition switch and Subaru Select Monitor or OBD-II general scan tool switch to ON.
- 7) Read data of engine coolant temperature sensor signal using Subaru Select Monitor or OBD-II general scan tool.

NOTE:

- Subaru Select Monitor

For detailed operation procedure, refer to the "READ CURRENT DATA SHOWN ON DISPLAY FOR ENGINE". <Ref. to 2-7 [T3C4].>

- OBD-II general scan tool

For detailed operation procedures, refer to the OBD-II General Scan Tool Instruction Manual.

- CHECK** : ***Is the value less than -40°C (-40°F)?***
- YES** : Replace engine coolant temperature sensor. <Ref. to 2-7 [W5A2].>
- NO** : Repair ground short circuit in harness between engine coolant temperature sensor and ECM connector.

ON-BOARD DIAGNOSTICS II SYSTEM

[T11H2] 2-7

11. Diagnostics Chart with Trouble Code for Except 2200 cc California Spec. Vehicles

MEMO:

I: DTC P0117 — ENGINE COOLANT TEMPERATURE SENSOR CIRCUIT HIGH INPUT —

- **DTC DETECTING CONDITION:**
 - Immediately at fault recognition
- **TROUBLE SYMPTOM:**
 - Hard to start
 - Erroneous idling
 - Poor driving performance

CAUTION:

After repair or replacement of faulty parts, conduct CLEAR MEMORY MODE <Ref. to 2-7 [T3D0].> and INSPECTION MODE <Ref. to 2-7 [T3E0].>

● **WIRING DIAGRAM:**

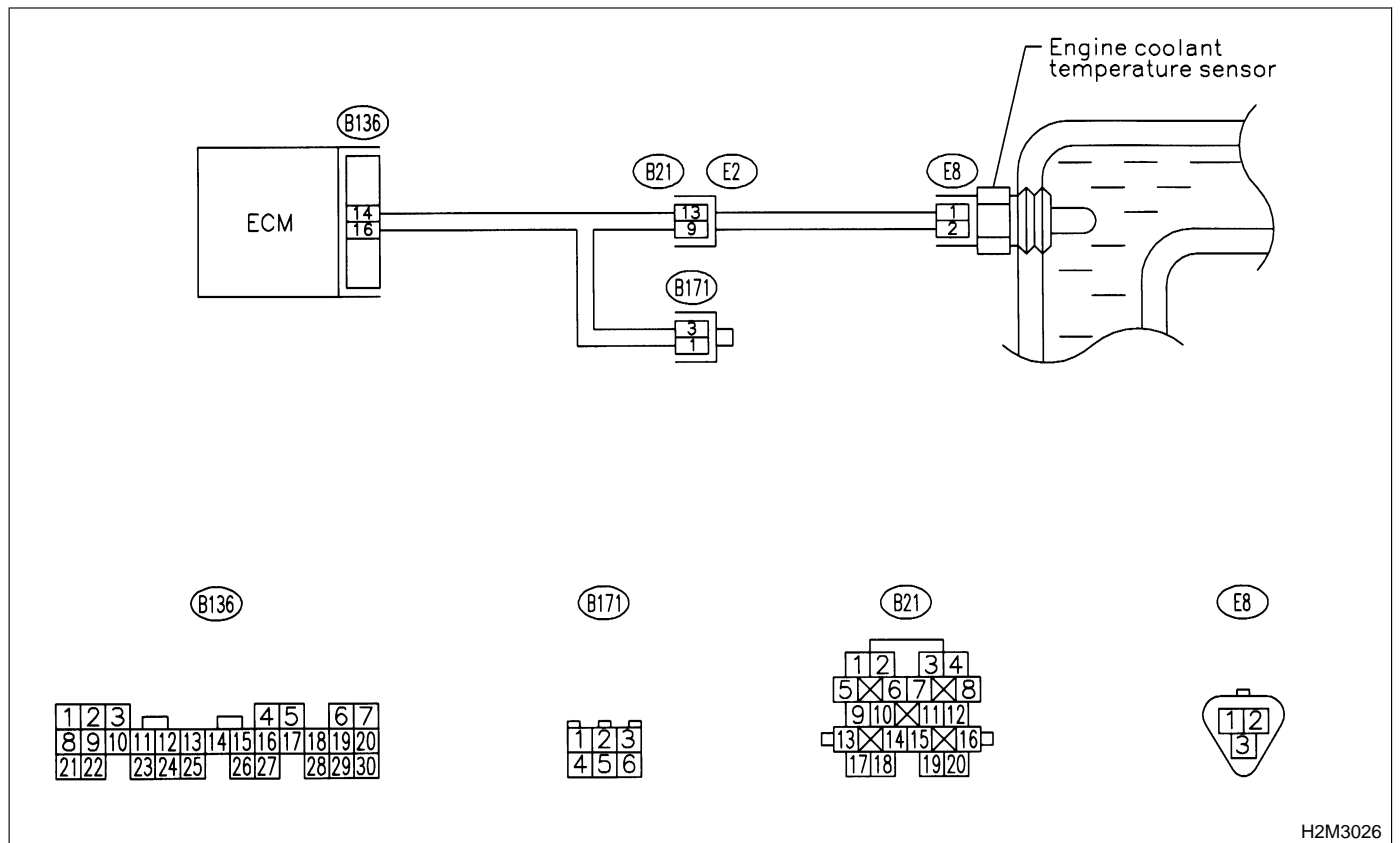

H2M3026

11I1 : CONNECT SUBARU SELECT MONITOR OR THE OBD-II GENERAL SCAN TOOL, AND READ DATA.

- 1) Turn ignition switch to OFF.
- 2) Connect Subaru Select Monitor or the OBD-II general scan tool to data link connector.

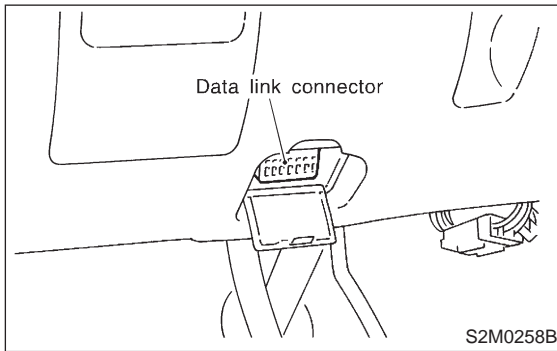

- 3) Turn ignition switch to ON and Subaru Select Monitor or OBD-II general scan tool switch to ON.
- 4) Start engine.
- 5) Read data of engine coolant temperature sensor signal using Subaru Select Monitor or OBD-II general scan tool.

NOTE:

- Subaru Select Monitor
For detailed operation procedure, refer to the "READ CURRENT DATA SHOWN ON DISPLAY FOR ENGINE". <Ref. to 2-7 [T3C4].>
- OBD-II general scan tool
For detailed operation procedures, refer to the OBD-II General Scan Tool Instruction Manual.

- CHECK** : *Is the value less than -40°C (-40°F)?*
- YES** : Go to step 11I2.
- NO** : Repair poor contact.

NOTE:

- In this case, repair the following:
- Poor contact in engine coolant temperature sensor
 - Poor contact in ECM
 - Poor contact in coupling connector (B21)

11I2 : CHECK HARNESS BETWEEN ENGINE COOLANT TEMPERATURE SENSOR AND ECM CONNECTOR.

- 1) Turn ignition switch to OFF.
- 2) Remove air intake duct and air intake chamber assembly as a unit.

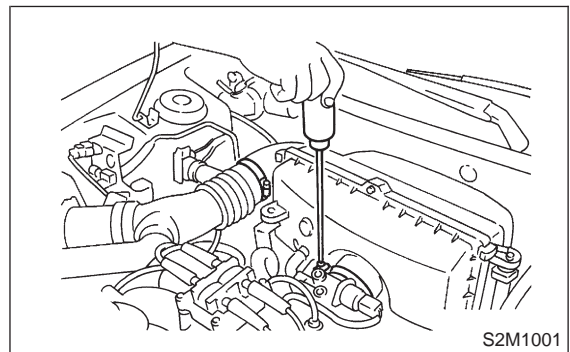

- 3) Remove engine harness connector bracket from cylinder block.

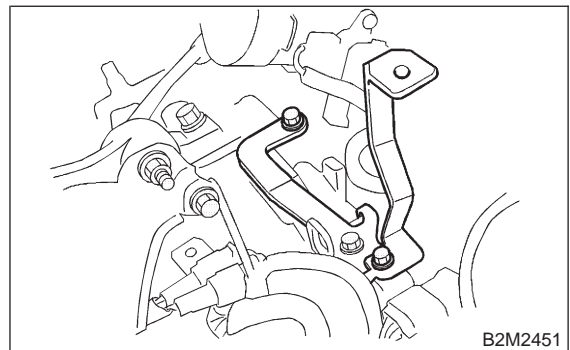

- 4) Remove blow-by hoses.



- 5) Disconnect connector from engine coolant temperature sensor.

6) Measure voltage between engine coolant temperature sensor connector and engine ground.

Connector & terminal

(E8) No. 1 (+) — Engine ground (-):

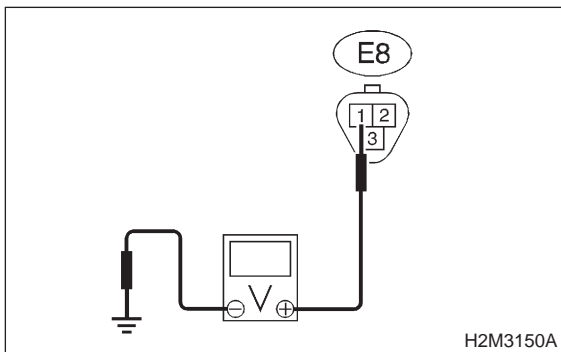

- CHECK** : **Is the voltage more than 10 V?**
- YES** : Repair battery short circuit in harness between ECM and engine coolant temperature sensor connector.
- NO** : Go to step 1113.

1113 : CHECK HARNESS BETWEEN ENGINE COOLANT TEMPERATURE SENSOR AND ECM CONNECTOR.

- 1) Turn ignition switch to ON.
- 2) Measure voltage between engine coolant temperature sensor connector and engine ground.

Connector & terminal

(E8) No. 1 (+) — Engine ground (-):

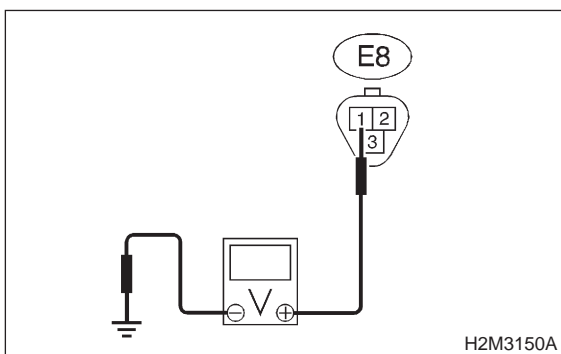

- CHECK** : **Is the voltage more than 10 V?**
- YES** : Repair battery short circuit in harness between ECM and engine coolant temperature sensor connector.
- NO** : Go to step 1114.

1114 : CHECK HARNESS BETWEEN ENGINE COOLANT TEMPERATURE SENSOR AND ECM CONNECTOR.

Measure voltage between engine coolant temperature sensor connector and engine ground.

Connector & terminal

(E8) No. 1 (+) — Engine ground (-):

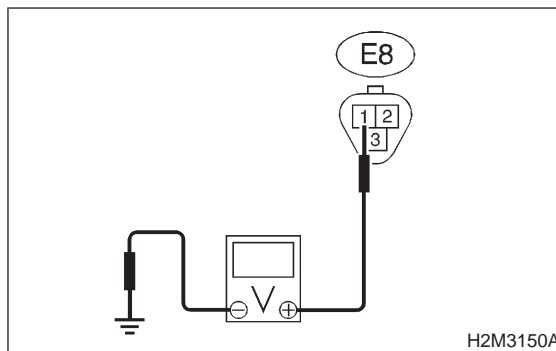

- CHECK** : **Is the voltage more than 4 V?**
- YES** : Go to step 1115.
- NO** : Repair harness and connector.

NOTE:

In this case, repair the following:

- Open circuit in harness between ECM and engine coolant temperature sensor connector
- Poor contact in engine coolant temperature sensor connector
- Poor contact in ECM connector
- Poor contact in coupling connector (B21)

1115 : CHECK HARNESS BETWEEN ENGINE COOLANT TEMPERATURE SENSOR AND ECM CONNECTOR.

- 1) Turn ignition switch to OFF.
- 2) Measure resistance of harness between engine coolant temperature sensor connector and engine ground.

Connector & terminal

(E8) No. 2 — Engine ground:

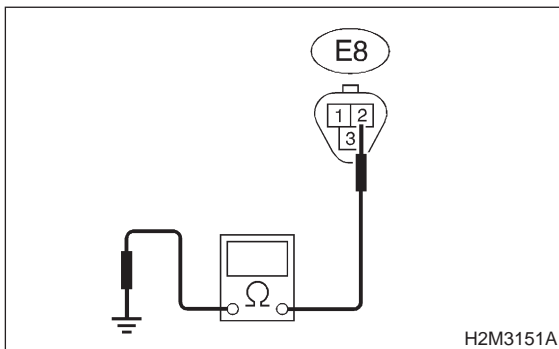

CHECK : **Is the resistance less than 5 Ω?**

YES : Replace engine coolant temperature sensor. <Ref. to 2-7 [W5A2].>

NO : Repair harness and connector.

NOTE:

In this case, repair the following:

- Open circuit in harness between ECM and engine coolant temperature sensor connector
- Poor contact in engine coolant temperature sensor connector
- Poor contact in ECM connector
- Poor contact in coupling connector (B21)

J: DTC P0121 — THROTTLE POSITION SENSOR CIRCUIT RANGE/PERFORMANCE PROBLEM (HIGH INPUT) —

- **DTC DETECTING CONDITION:**
 - Two consecutive driving cycles with fault
- **TROUBLE SYMPTOM:**
 - Erroneous idling
 - Engine stalls.
 - Poor driving performance

CAUTION:

After repair or replacement of faulty parts, conduct CLEAR MEMORY MODE <Ref. to 2-7 [T3D0].> and INSPECTION MODE <Ref. to 2-7 [T3E0].>.

● **WIRING DIAGRAM:**

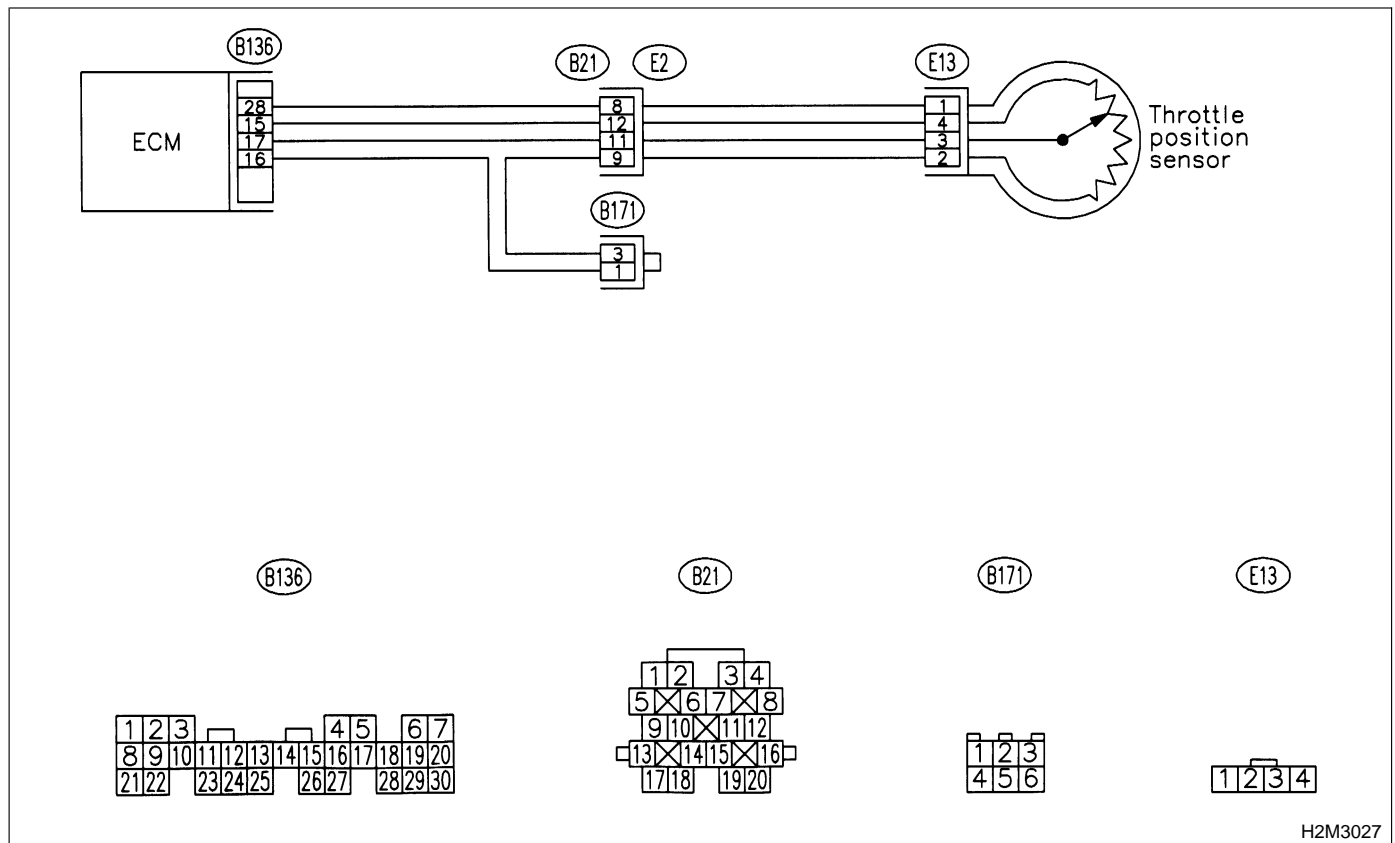

H2M3027

ON-BOARD DIAGNOSTICS II SYSTEM

[T11J1] 2-7

11. Diagnostics Chart with Trouble Code for Except 2200 cc California Spec. Vehicles

11J1 : CHECK ANY OTHER DTC ON DISPLAY.

CHECK : *Does the Subaru Select Monitor or OBD-II general scan tool indicate DTC P0122 or P0123?*

YES : Inspect DTC P0122 or P0123 using "11. Diagnostics Chart with Trouble Code for Except 2200 cc California Spec. Vehicles". <Ref. to 2-7 [T11A0].>

NOTE:

In this case, it is not necessary to inspect DTC P0121.

NO : Replace throttle position sensor. <Ref. to 2-7 [W9A2].>

K: DTC P0122 — THROTTLE POSITION SENSOR CIRCUIT LOW INPUT —

- **DTC DETECTING CONDITION:**
 - Immediately at fault recognition

- **TROUBLE SYMPTOM:**
 - Erroneous idling
 - Engine stalls.
 - Poor driving performance

CAUTION:

After repair or replacement of faulty parts, conduct CLEAR MEMORY MODE <Ref. to 2-7 [T3D0].> and INSPECTION MODE <Ref. to 2-7 [T3E0].>

● **WIRING DIAGRAM:**

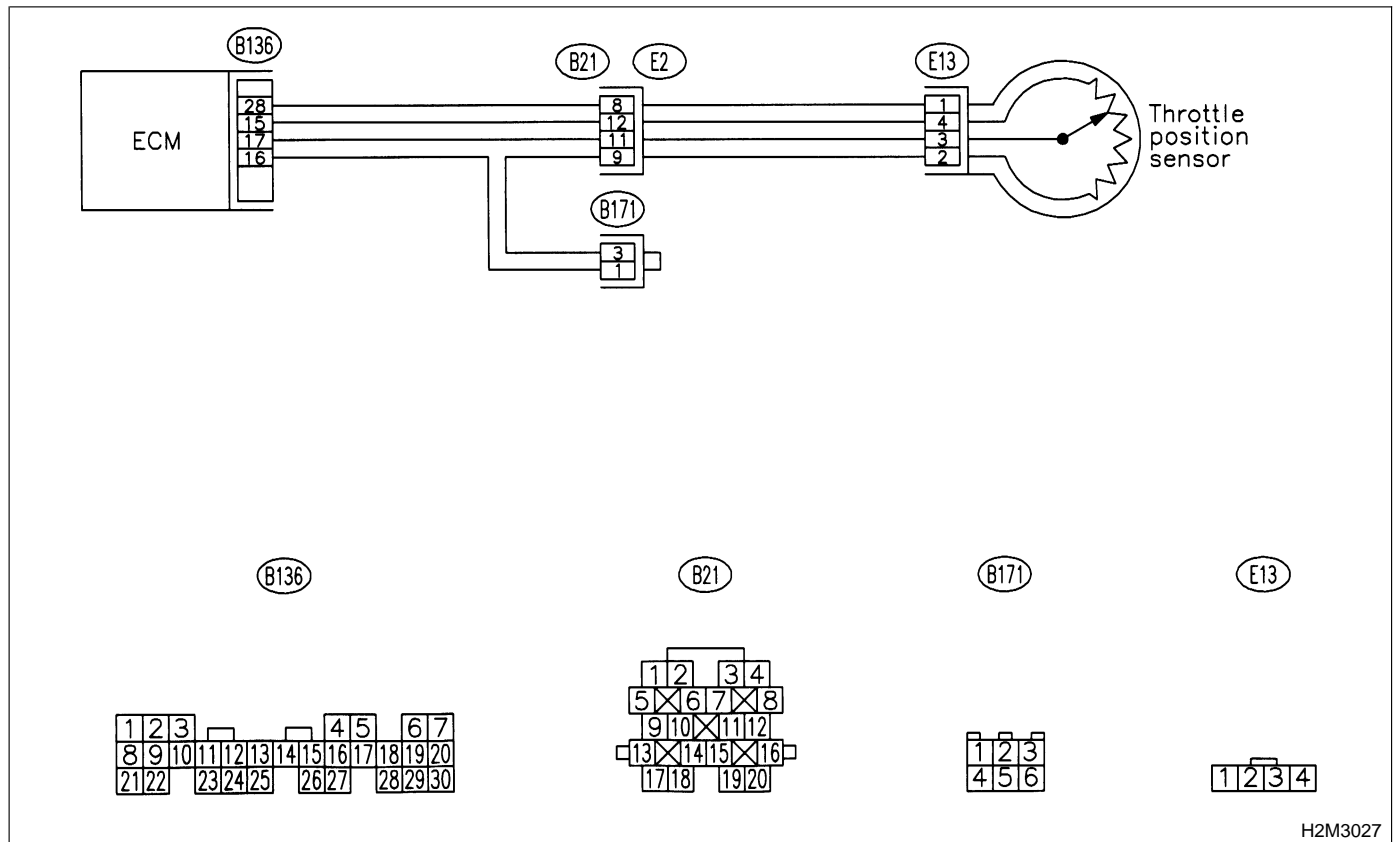

H2M3027

11K1 : CONNECT SUBARU SELECT MONITOR OR THE OBD-II GENERAL SCAN TOOL, AND READ DATA.

- 1) Turn ignition switch to OFF.
- 2) Connect Subaru Select Monitor or the OBD-II general scan tool to data link connector.

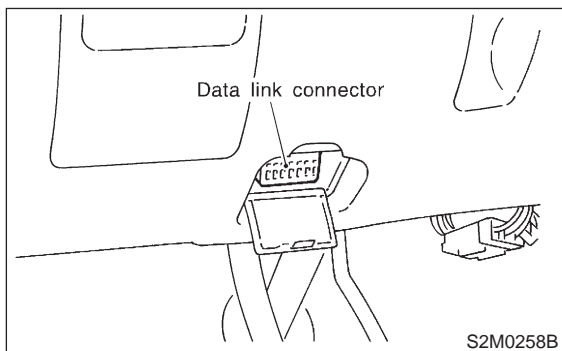

- 3) Turn ignition switch to ON and Subaru Select Monitor or OBD-II general scan tool switch to ON.
- 4) Start engine.
- 5) Read data of throttle position sensor signal using Subaru Select Monitor or OBD-II general scan tool.

NOTE:

- Subaru Select Monitor
For detailed operation procedure, refer to the "READ CURRENT DATA SHOWN ON DISPLAY FOR ENGINE". <Ref. to 2-7 [T3C4].>
- OBD-II general scan tool
For detailed operation procedures, refer to the OBD-II General Scan Tool Instruction Manual.

CHECK : *Is the value less than 0.1 V?*

YES : Go to step 11K2.

NO : Even if MIL lights up, the circuit has returned to a normal condition at this time. A temporary poor contact of the connector may be the cause.

NOTE:

In this case, repair the following:

- Poor contact in throttle position sensor connector
- Poor contact in ECM connector
- Poor contact in coupling connector (B21)

11K2 : CHECK INPUT SIGNAL FOR ECM.

Measure voltage between ECM connector and chassis ground while throttle valve is fully closed.

Connector & terminal

(B136) No. 15 (+) — Chassis ground (-):

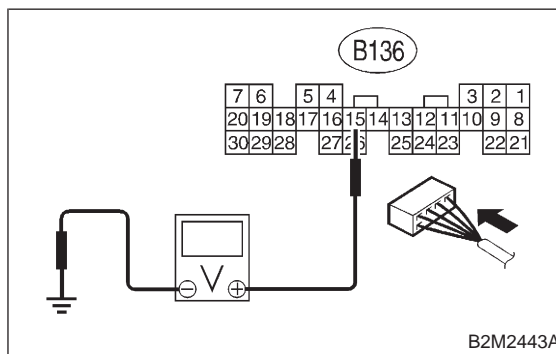

CHECK : *Is the voltage more than 4.5 V?*

YES : Go to step 11K4.

NO : Go to step 11K3.

11K3 : CHECK INPUT SIGNAL FOR ECM.

Measure voltage between ECM connector and chassis ground.

Connector & terminal

(B136) No. 15 (+) — Chassis ground (-):

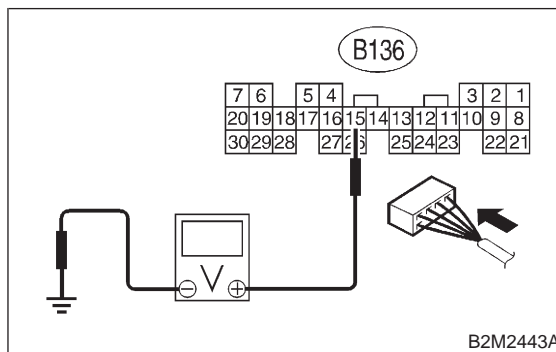

CHECK : *Does the voltage change more than 4.5 V by shaking harness and connector of ECM while monitoring the value with voltage meter?*

YES : Repair poor contact in ECM connector.

NO : Contact with SOA service.

NOTE:

Inspection by DTM is required, because probable cause is deterioration of multiple parts.

2-7 [T11K4]

ON-BOARD DIAGNOSTICS II SYSTEM

11. Diagnostics Chart with Trouble Code for Except 2200 cc California Spec. Vehicles

11K4 : CHECK INPUT SIGNAL FOR ECM.

Measure voltage between ECM connector and chassis ground.

Connector & terminal
(B136) No. 17 (+) — Chassis ground (-):

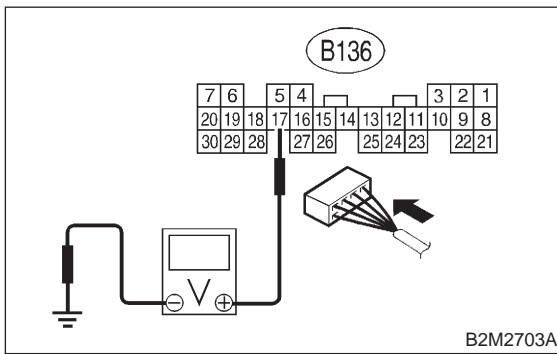

- CHECK** : Is the voltage less than 0.1 V?
YES : Go to step 11K6.
NO : Go to step 11K5.

11K5 : CHECK INPUT SIGNAL FOR ECM. (USING SUBARU SELECT MONITOR.)

Measure voltage between ECM connector and chassis ground.

- CHECK** : Does the voltage change more than 0.1 V by shaking harness and connector of ECM while monitoring the value with Subaru Select Monitor?
YES : Repair poor contact in ECM connector.
NO : Go to step 11K6.

11K6 : CHECK HARNESS BETWEEN ECM AND THROTTLE POSITION SENSOR CONNECTOR.

- 1) Turn ignition switch to OFF.
- 2) Disconnect connectors from throttle position sensor.
- 3) Turn ignition switch to ON.
- 4) Measure voltage between throttle position sensor connector and engine ground.

Connector & terminal
(E13) No. 4 (+) — Engine ground (-):

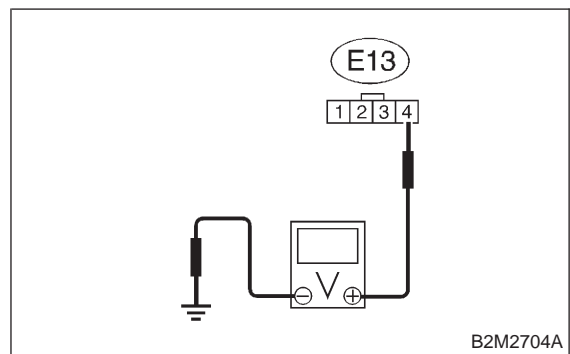

- CHECK** : Is the voltage more than 4.5 V?
YES : Go to step 11K7.
NO : Repair harness and connector.

NOTE:

In this case, repair the following:

- Open circuit in harness between throttle position sensor and ECM connector
- Poor contact in throttle position sensor connector
- Poor contact in ECM connector
- Poor contact in coupling connector (B21)

11K7 : CHECK HARNESS BETWEEN ECM AND THROTTLE POSITION SENSOR CONNECTOR.

- 1) Turn ignition switch to OFF.
- 2) Measure resistance of harness between ECM connector and throttle position sensor connector.

Connector & terminal

(B136) No. 17 — (E13) No. 3:

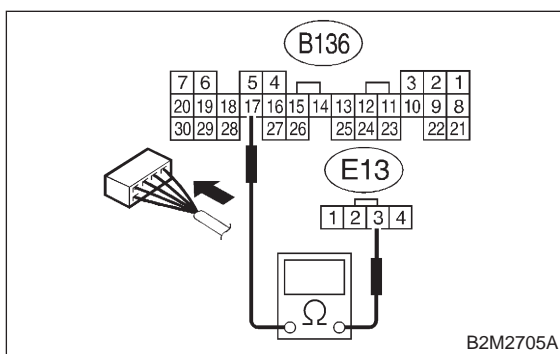

CHECK : *Is the resistance less than 1 Ω?*

YES : Go to step 11K8.

NO : Repair harness and connector.

NOTE:

In this case, repair the following:

- Open circuit in harness between throttle position sensor and ECM connector
- Poor contact in ECM connector
- Poor contact in throttle position sensor connector
- Poor contact in coupling connector (B21)

11K8 : CHECK HARNESS BETWEEN ECM AND THROTTLE POSITION SENSOR CONNECTOR.

Measure resistance of harness between throttle position sensor connector and engine ground.

Connector & terminal

(E13) No. 3 — Engine ground:

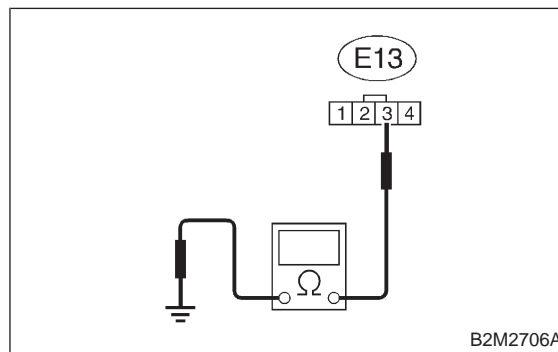

CHECK : *Is the resistance less than 10 Ω?*

YES : Repair ground short circuit in harness between throttle position sensor and ECM connector.

NO : Go to step 11K9.

11K9 : CHECK POOR CONTACT.

Check poor contact in throttle position sensor connector. <Ref. to FOREWORD [T3C1].>

CHECK : *Is there poor contact in throttle position sensor connector?*

YES : Repair poor contact in throttle position sensor connector.

NO : Replace throttle position sensor. <Ref. to 2-7 [W9A2].>

L: DTC P0123 — THROTTLE POSITION SENSOR CIRCUIT HIGH INPUT —

- **DTC DETECTING CONDITION:**
 - Immediately at fault recognition

- **TROUBLE SYMPTOM:**
 - Erroneous idling
 - Engine stalls.
 - Poor driving performance

CAUTION:

After repair or replacement of faulty parts, conduct CLEAR MEMORY MODE <Ref. to 2-7 [T3D0].> and INSPECTION MODE <Ref. to 2-7 [T3E0].>

● **WIRING DIAGRAM:**

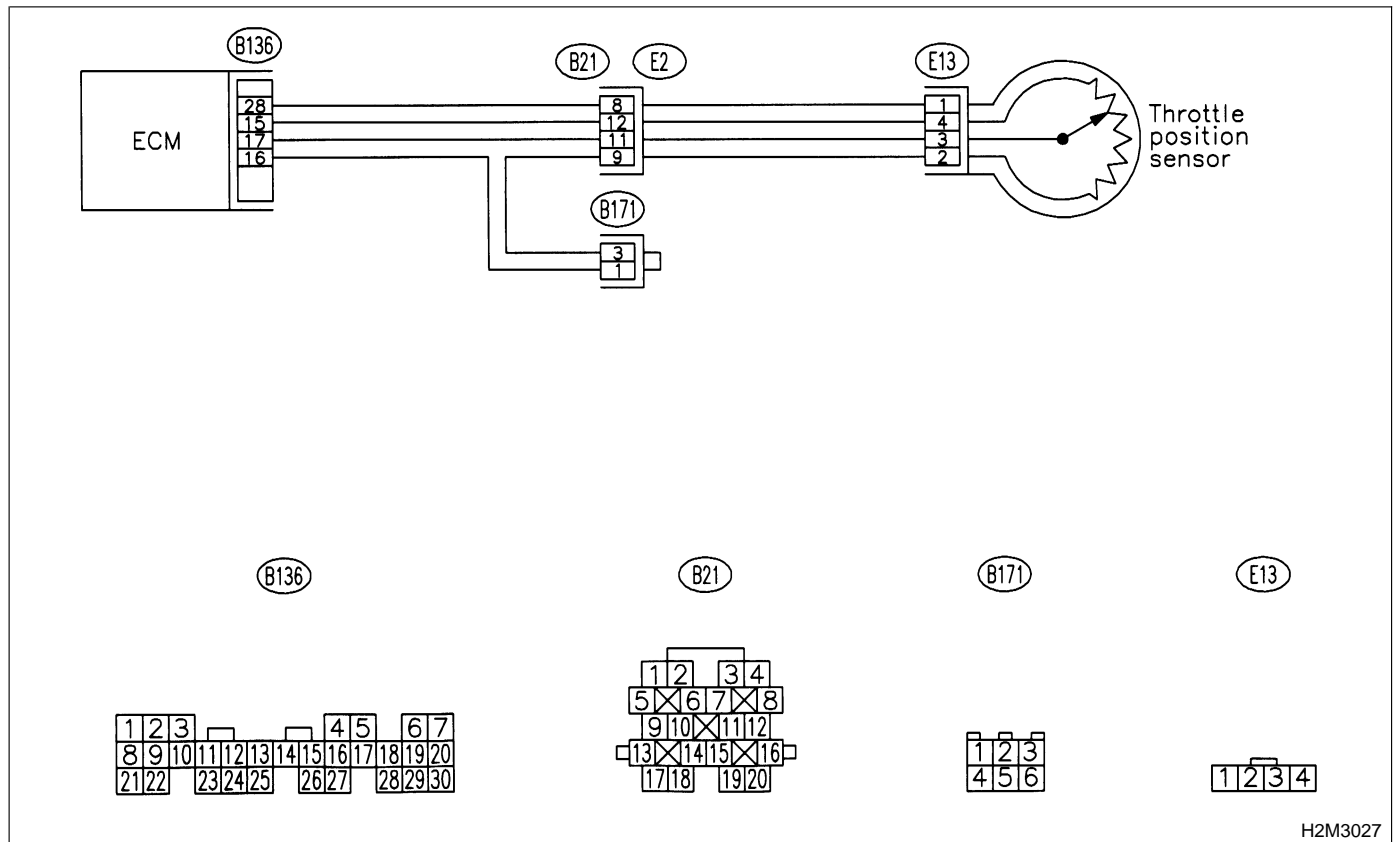

11L1 : CONNECT SUBARU SELECT MONITOR OR THE OBD-II GENERAL SCAN TOOL, AND READ DATA.

- 1) Turn ignition switch to OFF.
- 2) Connect Subaru Select Monitor or the OBD-II general scan tool to data link connector.

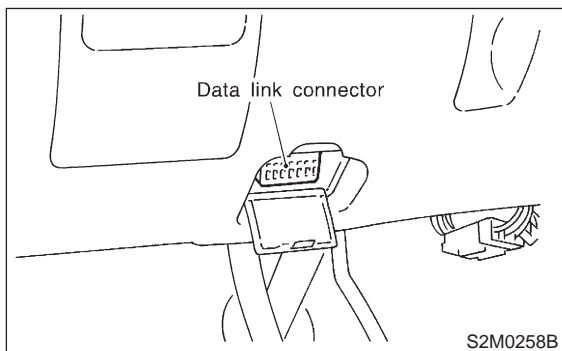

- 3) Turn ignition switch to ON and Subaru Select Monitor or OBD-II general scan tool switch to ON.
- 4) Start engine.
- 5) Read data of throttle position sensor signal using Subaru Select Monitor or OBD-II general scan tool.

NOTE:

- Subaru Select Monitor
For detailed operation procedure, refer to the "READ CURRENT DATA SHOWN ON DISPLAY FOR ENGINE". <Ref. to 2-7 [T3C4].>
- OBD-II general scan tool
For detailed operation procedures, refer to the OBD-II General Scan Tool Instruction Manual.

- CHECK** : *Is the value more than 4.9 V?*
- YES** : Go to step 11L2.
- NO** : Even if MIL lights up, the circuit has returned to a normal condition at this time. A temporary poor contact of the connector may be the cause.

NOTE:

- In this case, repair the following:
- Poor contact in throttle position sensor connector
 - Poor contact in ECM connector
 - Poor contact in coupling connector (B21)
 - Poor contact in joint connector (B171)

11L2 : CHECK HARNESS BETWEEN THROTTLE POSITION SENSOR AND ECM CONNECTOR.

- 1) Turn ignition switch to OFF.
- 2) Disconnect connector from throttle position sensor.
- 3) Measure resistance of harness between throttle position sensor connector and engine ground.

Connector & terminal
(E13) No. 2 — Engine ground:

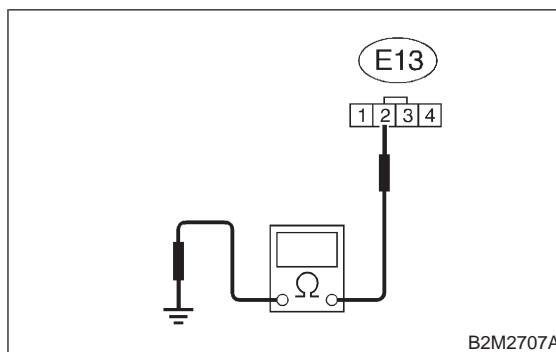

- CHECK** : *Is the resistance less than 5 Ω?*
- YES** : Go to step 11L3.
- NO** : Repair harness and connector.

NOTE:

- In this case, repair the following:
- Open circuit in harness between throttle position sensor and ECM connector
 - Poor contact in coupling connector (B21)
 - Poor contact in joint connector (B171)

11L3 : CHECK HARNESS BETWEEN THROTTLE POSITION SENSOR AND ECM CONNECTOR.

- 1) Turn ignition switch to ON.
- 2) Measure voltage between throttle position sensor connector and engine ground.

Connector & terminal

(E13) No. 3 (+) — Engine ground (-):

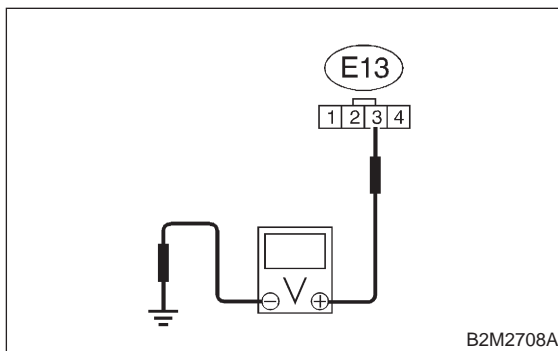

- CHECK** : **Is the voltage more than 4.9 V?**
- YES** : Repair battery short circuit in harness between throttle position sensor and ECM connector. After repair, replace ECM. <Ref. to 2-7 [W15A0].>
- NO** : Replace throttle position sensor. <Ref. to 2-7 [W9A2].>

M: DTC P0125 — INSUFFICIENT COOLANT TEMPERATURE FOR CLOSED LOOP FUEL CONTROL —

- **DTC DETECTING CONDITION:**
 - Two consecutive driving cycles with fault
- **TROUBLE SYMPTOM:**
 - Engine would not return to idling.

CAUTION:

After repair or replacement of faulty parts, conduct **CLEAR MEMORY MODE** <Ref. to 2-7 [T3D0].> and **INSPECTION MODE** <Ref. to 2-7 [T3E0].>

● **WIRING DIAGRAM:**

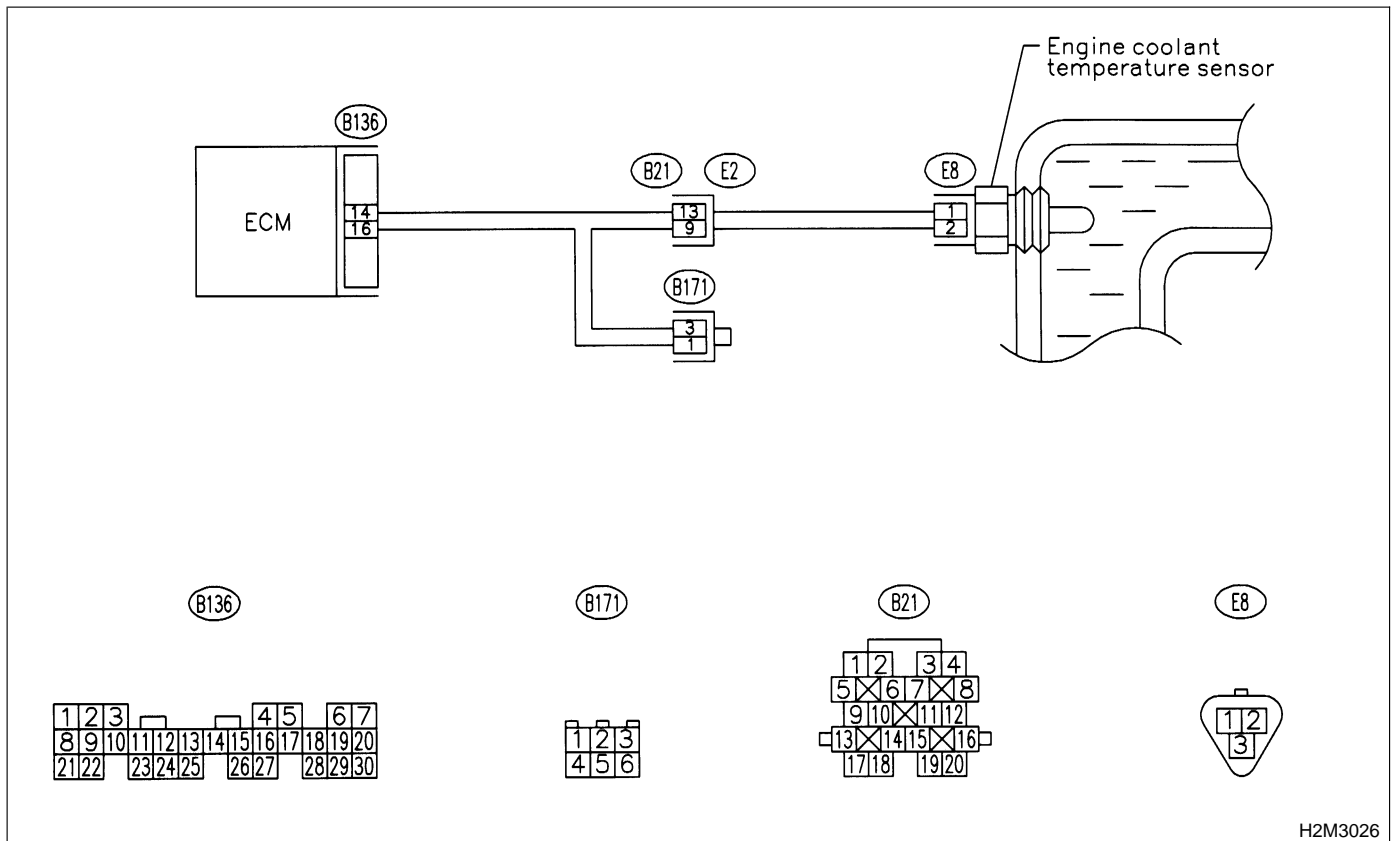

H2M3026

11M1 : CHECK ANY OTHER DTC ON DISPLAY.

- CHECK** : Does the Subaru Select Monitor or OBD-II general scan tool indicate DTC P0116 or P0117?
- YES** : Inspect DTC P0116 or P0117 using "11. Diagnostics Chart with Trouble Code for Except 2200 cc California Spec. Vehicles". <Ref. to 2-7 [T11A0].>

NOTE:

In this case, it is not necessary to inspect DTC P0125.

- NO** : Replace engine coolant temperature sensor. <Ref. to 2-7 [W5A2].>

N: DTC P0130 — FRONT OXYGEN SENSOR CIRCUIT MALFUNCTION —

- **DTC DETECTING CONDITION:**
 - Two consecutive driving cycles with fault

CAUTION:

After repair or replacement of faulty parts, conduct CLEAR MEMORY MODE <Ref. to 2-7 [T3D0].> and INSPECTION MODE <Ref. to 2-7 [T3E0].>

● **WIRING DIAGRAM:**

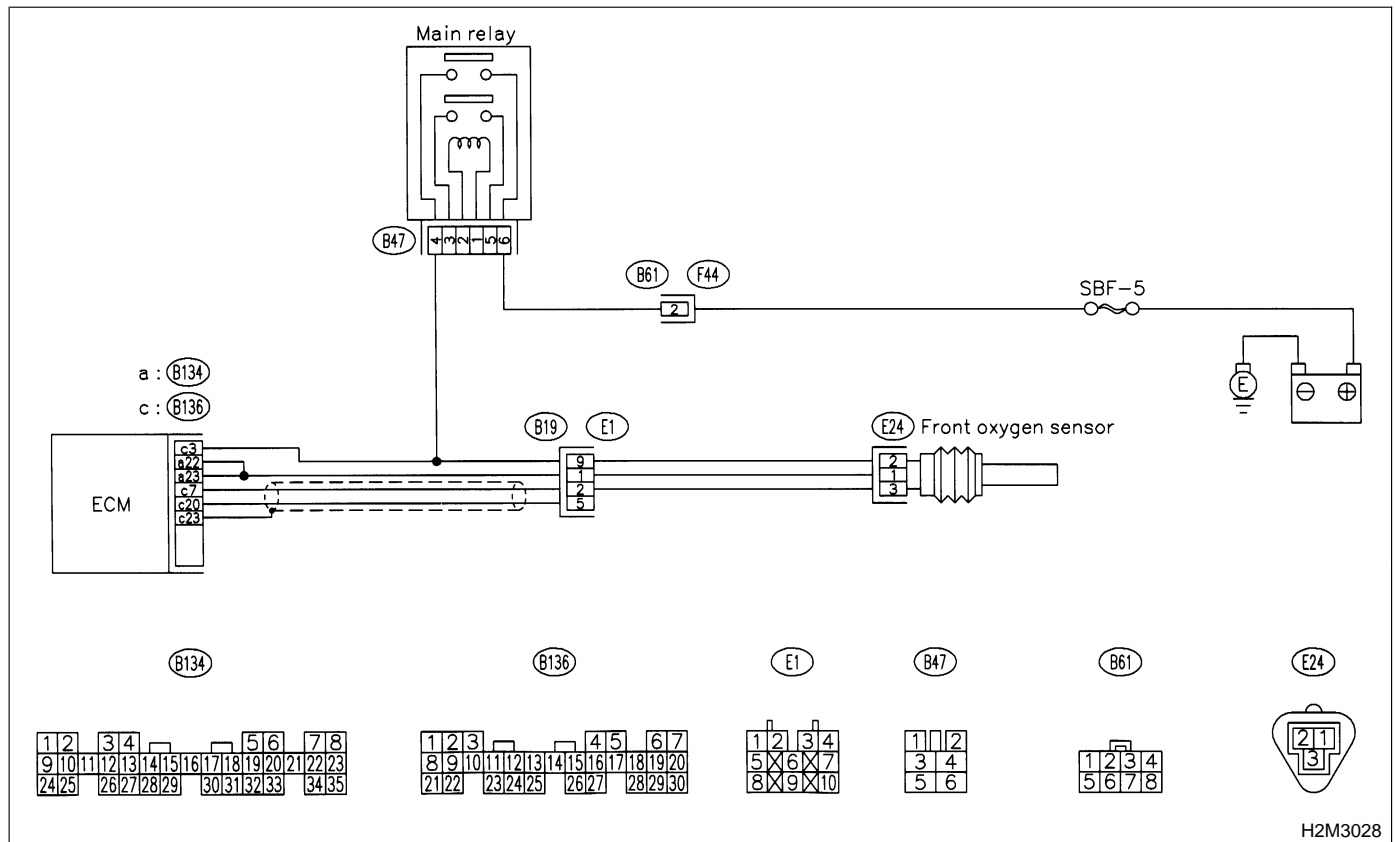

11N1 : CHECK FOR OTHER CAUSES AFFECTING EXHAUST GAS.

NOTE:

- Check for use of improper fuel.
- Check if engine oil or coolant level is extremely low.

CHECK : *Is CO % more than 2 % after engine warm-up?*

YES : Check fuel system.

NO : Go to step 11N2.

11N2 : CHECK FRONT OXYGEN SENSOR DATA.

- 1) Turn ignition switch to OFF.
- 2) Connect the Subaru Select Monitor or the OBD-II general scan tool to data link connector.

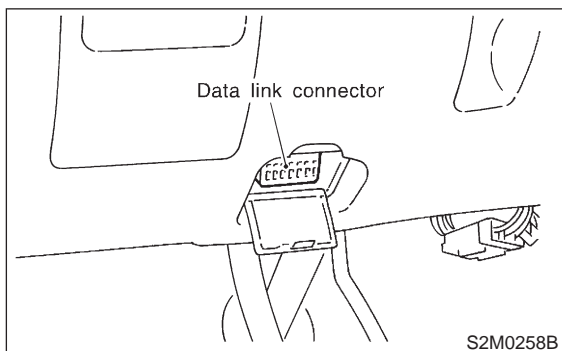

- 3) Start engine and Turn the Subaru Select Monitor and the OBD-II general scan tool switch to ON.
- 4) Warm-up the engine until coolant temperature is above 70°C (160°F) and keep the engine speed at 2,000 rpm to 3,000 rpm for one minute.
- 5) Read data of front oxygen sensor signal using Subaru Select Monitor or OBD-II general scan tool.

NOTE:

- Subaru Select Monitor

For detailed operation procedure, refer to the "READ OXYGEN SENSOR MONITORING TEST RESULTS DATA SHOWN ON DISPLAY FOR ENGINE". <Ref. to 2-7 [T3C7].>

- OBD-II general scan tool

For detailed operation procedures, refer to the OBD-II General Scan Tool Instruction Manual.

CHECK : *Is the difference of voltage less than 0.1 V between the value of max. output and min. output?*

YES : Go to step 11N3.

NO : Replace front oxygen sensor. <Ref. to 2-7 [W7A0].>

11N3 : CHECK HARNESS BETWEEN FRONT OXYGEN SENSOR AND ECM CONNECTOR.

- 1) Turn ignition switch to OFF.
- 2) Disconnect connector from front oxygen sensor.
- 3) Turn ignition switch to ON.
- 4) Measure voltage between front oxygen sensor harness connector and engine ground.

Connector & terminal

(E24) No. 3 (+) — Engine ground (-):

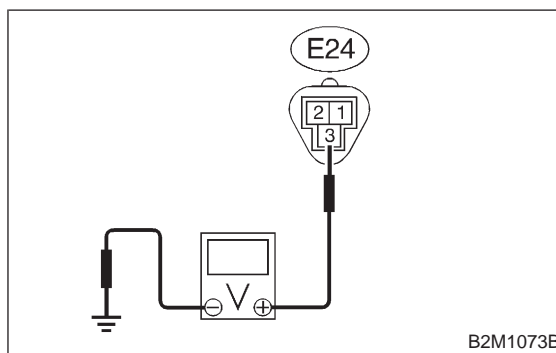

CHECK : *Is the voltage more than 0.2 V?*

YES : Go to step 11N4.

NO : Repair harness and connector.

NOTE:

In this case, repair the following:

- Open circuit in harness between ECM and front oxygen sensor connector
- Poor contact in the ECM connector

11N4 : CHECK POOR CONTACT.

Check poor contact in front oxygen sensor connector. <Ref. to FOREWORD [T3C1].>

CHECK : *Is there poor contact in front oxygen sensor connector?*

YES : Repair poor contact in front oxygen sensor connector.

NO : Replace front oxygen sensor. <Ref. to 2-7 [W7A0].>

O: DTC P0133 — FRONT OXYGEN SENSOR CIRCUIT SLOW RESPONSE —

- **DTC DETECTING CONDITION:**
 - Two consecutive driving cycles with fault

CAUTION:

After repair or replacement of faulty parts, conduct CLEAR MEMORY MODE <Ref. to 2-7 [T3D0].> and INSPECTION MODE <Ref. to 2-7 [T3E0].>

● **WIRING DIAGRAM:**

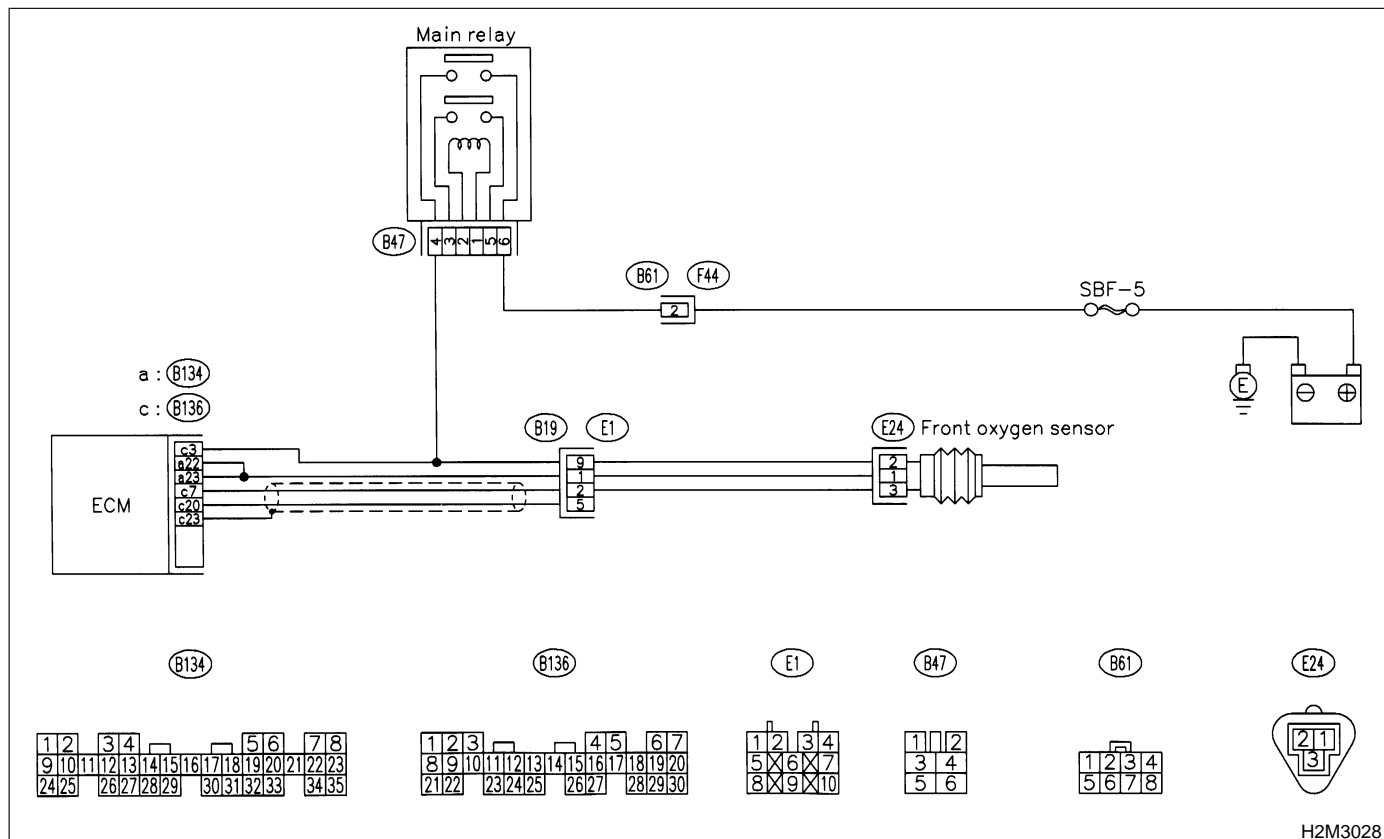

1101 : CHECK ANY OTHER DTC ON DISPLAY.

CHECK : Does the Subaru Select Monitor or OBD-II general scan tool indicate DTC P0130?

YES : Inspect DTC P0130 using "11. Diagnostics Chart with Trouble Code for Except 2200 cc California Spec. Vehicles". <Ref. to 2-7 [T11A0].>

NOTE:

In this case, it is not necessary to inspect DTC P0133.

NO : Go to step 1102.

1102 : CHECK EXHAUST SYSTEM.

NOTE:

Check the following items.

- Loose installation of front portion of exhaust pipe onto cylinder heads
- Loose connection between front exhaust pipe and front catalytic converter
- Damage of exhaust pipe resulting in a hole

CHECK : Is there a fault in exhaust system?

YES : Repair exhaust system.

NO : Replace front oxygen sensor. <Ref. to 2-7 [W7A0].>

ON-BOARD DIAGNOSTICS II SYSTEM

[T1102] 2-7

11. Diagnostics Chart with Trouble Code for Except 2200 cc California Spec. Vehicles

MEMO:

P: DTC P0135 — FRONT OXYGEN SENSOR HEATER CIRCUIT MALFUNCTION —

- **DTC DETECTING CONDITION:**
 - Two consecutive driving cycles with fault

CAUTION:

After repair or replacement of faulty parts, conduct **CLEAR MEMORY MODE** <Ref. to 2-7 [T3D0].> and **INSPECTION MODE** <Ref. to 2-7 [T3E0].>

● **WIRING DIAGRAM:**

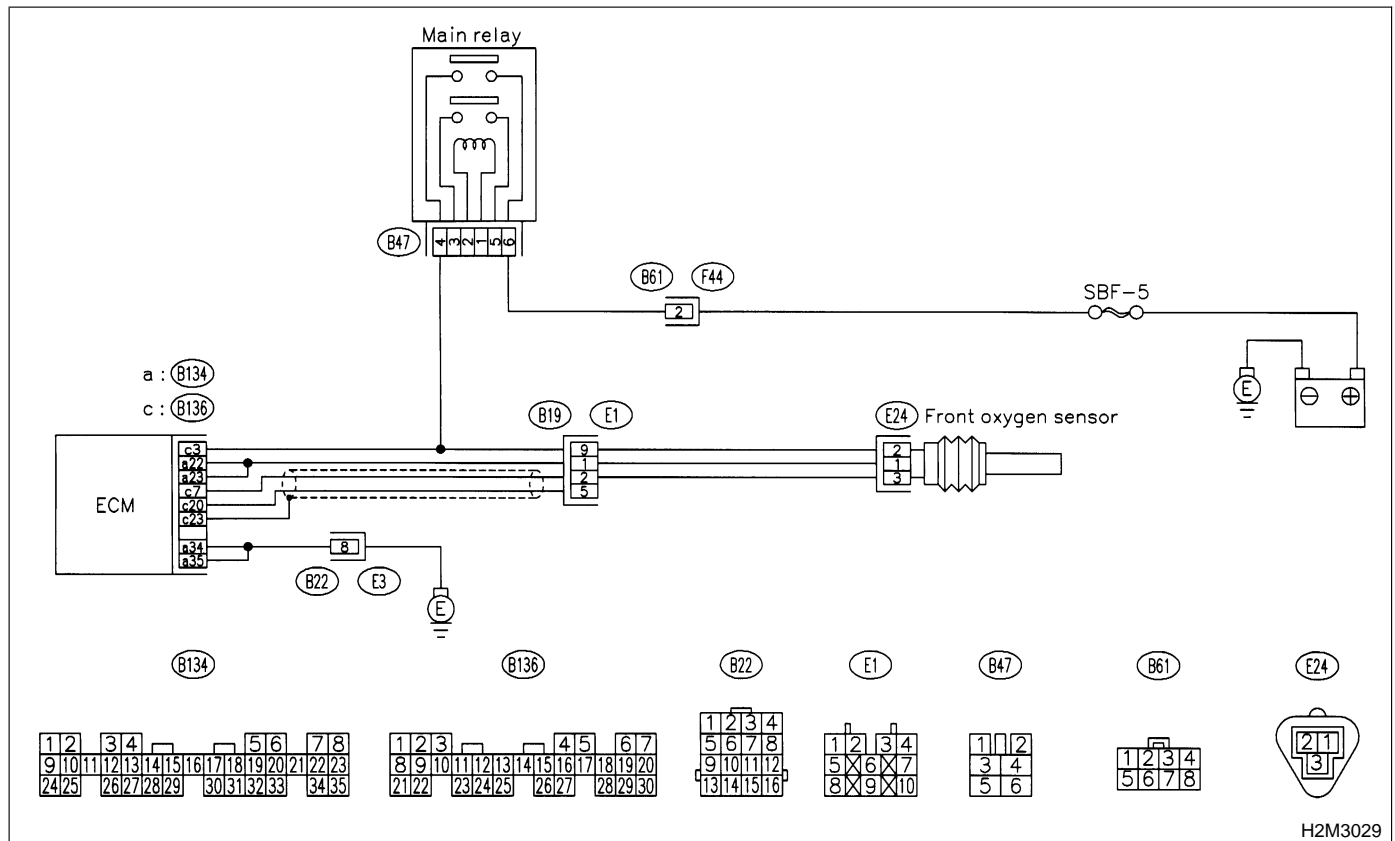

11P1 : CHECK ANY OTHER DTC ON DISPLAY.

- CHECK** : Does the Subaru Select Monitor or OBD-II general scan tool indicate DTC P0135 and P0141 at the same time?
- YES** : Go to step 11P2.
- NO** : Go to step 11P4.

11P2 : CHECK GROUND CIRCUIT OF ECM.

- 1) Turn ignition switch to OFF.
- 2) Disconnect connector from ECM.
- 3) Measure resistance of harness between ECM connector and chassis ground.

Connector & terminal
(B134) No. 35 — Chassis ground:

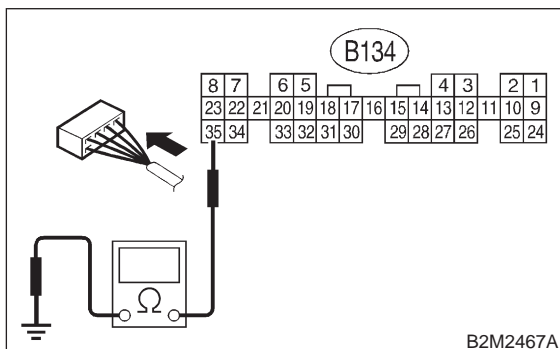

- CHECK** : Is the resistance less than 5 Ω?
- YES** : Go to step 11P4.
- NO** : Go to step 11P3.

11P3 : CHECK GROUND CIRCUIT OF ECM.

- 1) Repair harness and connector.

NOTE:

In this case, repair the following:

- Open circuit in harness between ECM and engine ground terminal
- Poor contact in ECM connector
- Poor contact in coupling connector (B22)

- 2) Measure resistance of harness between ECM connector and chassis ground.

Connector & terminal
(B134) No. 34 — Chassis ground:

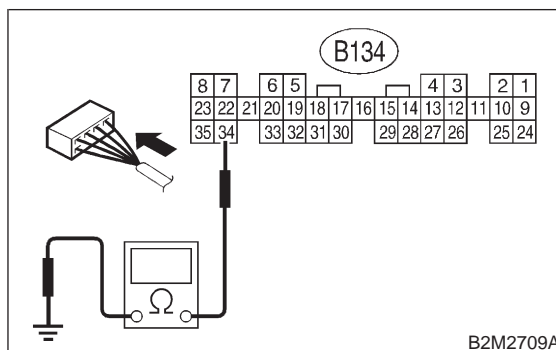

- CHECK** : Is the resistance less than 5 Ω?
- YES** : Go to step 11P4.
- NO** : Repair harness and connector.

NOTE:

In this case, repair the following:

- Open circuit in harness between ECM and engine ground terminal
- Poor contact in ECM connector
- Poor contact in coupling connector (B22)

2-7 [T11P4]

ON-BOARD DIAGNOSTICS II SYSTEM

11. Diagnostics Chart with Trouble Code for Except 2200 cc California Spec. Vehicles

11P4 : CONNECT SUBARU SELECT MONITOR OR THE OBD-II GENERAL SCAN TOOL, AND READ DATA.

- 1) Turn ignition switch to OFF.
- 2) Connect Subaru Select Monitor or the OBD-II general scan tool to data link connector.

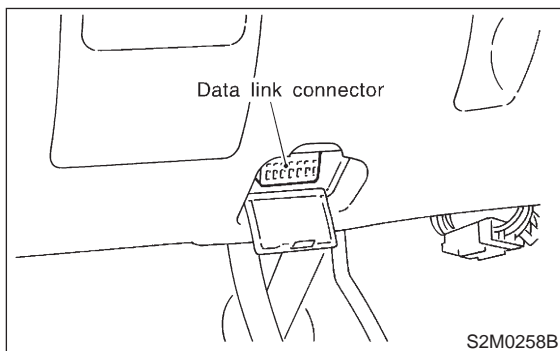

- 3) Turn ignition switch to ON and Subaru Select Monitor or OBD-II general scan tool switch to ON.
- 4) Start engine
- 5) Read data of front oxygen sensor heater current using Subaru Select Monitor or OBD-II general scan tool.

NOTE:

- Subaru Select Monitor
For detailed operation procedure, refer to the "READ CURRENT DATA SHOWN ON DISPLAY FOR ENGINE". <Ref. to 2-7 [T3C4].>

- OBD-II scan tool
For detailed operation procedures, refer to the OBD-II General Scan Tool Instruction Manual.

CHECK : *Is the value more than 0.2 A?*

YES : Repair connector.

NOTE:

In this case, repair the following:

- Poor contact in front oxygen sensor connector
- Poor contact in ECM connector

NO : Go to step 11P5.

11P5 : CHECK OUTPUT SIGNAL FROM ECM.

- 1) Start and idle the engine.
- 2) Measure voltage between ECM connector and chassis ground.

Connector & terminal

(B134) No. 22 (+) — Chassis ground (-):

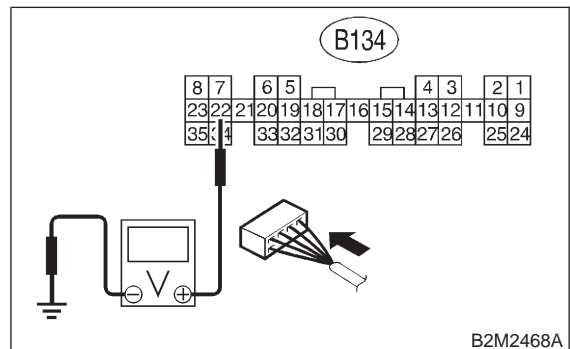

CHECK : *Is the voltage less than 1.0 V?*

YES : Go to step 11P11.

NO : Go to step 11P6.

11P6 : CHECK OUTPUT SIGNAL FROM ECM.

Measure voltage between ECM connector and chassis ground.

Connector & terminal

(B134) No. 22 (+) — Chassis ground (-):

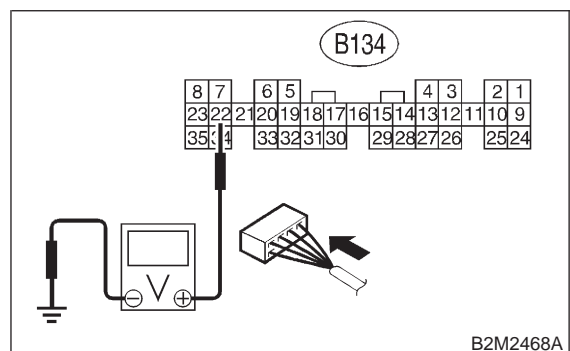

CHECK : *Does the voltage change less than 1.0 V by shaking harness and connector of ECM while monitoring the value with voltage meter?*

YES : Repair poor contact in ECM connector.

NO : Go to step 11P7.

11P7 : CHECK OUTPUT SIGNAL FROM ECM.

Measure voltage between ECM connector and chassis ground.

Connector & terminal
(B134) No. 23 (+) — Chassis ground (-):

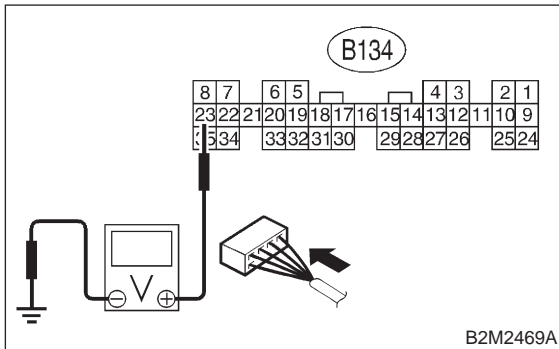

- CHECK** : *Is the voltage less than 1.0 V?*
- YES** : Go to step 11P11.
- NO** : Go to step 11P8.

11P8 : CHECK OUTPUT SIGNAL FROM ECM.

Measure voltage between ECM connector and chassis ground.

Connector & terminal
(B134) No. 23 (+) — Chassis ground (-):

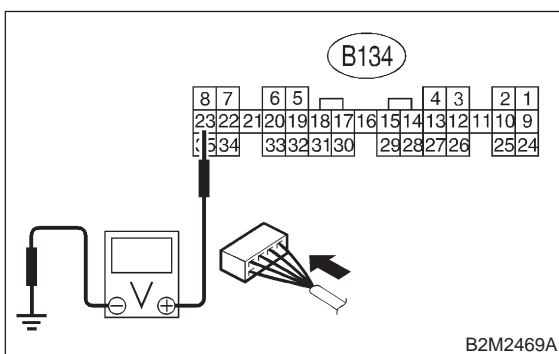

- CHECK** : *Does the voltage change less than 1.0 V by shaking harness and connector of ECM while monitoring the value with voltage meter?*
- YES** : Repair poor contact in ECM connector.
- NO** : Go to step 11P9.

11P9 : CHECK OUTPUT SIGNAL FROM ECM.

- 1) Disconnect connector from front oxygen sensor.
- 2) Measure voltage between ECM connector and chassis ground.

Connector & terminal
(B134) No. 22 (+) — Chassis ground (-):

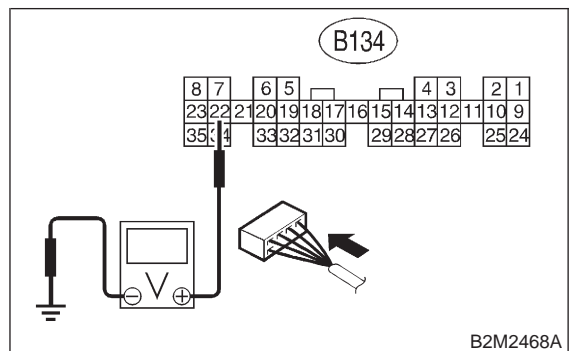

- CHECK** : *Is the voltage less than 1.0 V?*
- YES** : Go to step 11P10.
- NO** : Repair battery short circuit in harness between ECM and front oxygen sensor connector. After repair, replace ECM. <Ref. to 2-7 [W15A0].>

11P10 : CHECK OUTPUT SIGNAL FROM ECM.

Measure voltage between ECM connector and chassis ground.

Connector & terminal
(B134) No. 23 (+) — Chassis ground (-):

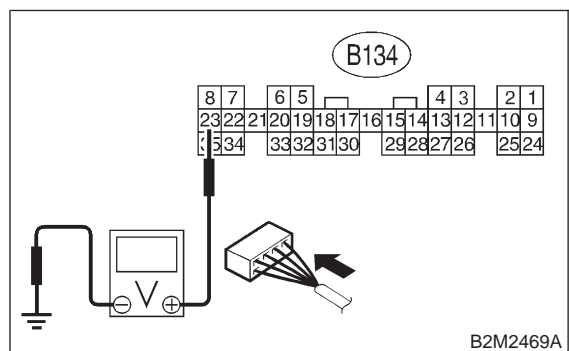

- CHECK** : *Is the voltage less than 1.0 V?*
- YES** : Replace ECM. <Ref. to 2-7 [W15A0].>
- NO** : Repair battery short circuit in harness between ECM and front oxygen sensor connector. After repair, replace ECM. <Ref. to 2-7 [W15A0].>

2-7 [T11P11]

ON-BOARD DIAGNOSTICS II SYSTEM

11. Diagnostics Chart with Trouble Code for Except 2200 cc California Spec. Vehicles

11P11 : CHECK POWER SUPPLY TO FRONT OXYGEN SENSOR.

- 1) Turn ignition switch to OFF.
- 2) Disconnect connector from front oxygen sensor.
- 3) Turn ignition switch to ON.
- 4) Measure voltage between front oxygen sensor connector and engine ground.

Connector & terminal

(E24) No. 2 (+) — Engine ground (-):

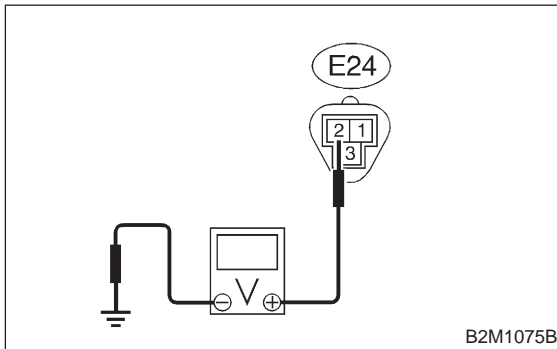

CHECK : Is the voltage more than 10 V?

YES : Go to step 11P12.

NO : Repair power supply line.

NOTE:

In this case, repair the following:

- Open circuit in harness between main relay and front oxygen sensor connector
- Poor contact in front oxygen sensor connector
- Poor contact in main relay connector

11P12 : CHECK FRONT OXYGEN SENSOR.

- 1) Turn ignition switch to OFF.
- 2) Measure resistance between front oxygen sensor connector terminals.

Terminals

No. 1 — No. 2:

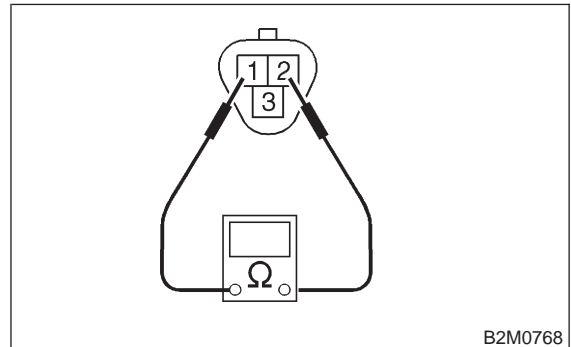

CHECK : Is the resistance less than 30 Ω ?

YES : Repair harness and connector.

NOTE:

In this case, repair the following:

- Open circuit in harness between front oxygen sensor and ECM connector
- Poor contact in front oxygen sensor connector
- Poor contact in ECM connector

NO : Replace front oxygen sensor. <Ref. to 2-7 [W7A0].>

Q: DTC P0136 — REAR OXYGEN SENSOR CIRCUIT MALFUNCTION —

- **DTC DETECTING CONDITION:**
 - Two consecutive driving cycles with fault

CAUTION:

After repair or replacement of faulty parts, conduct CLEAR MEMORY MODE <Ref. to 2-7 [T3D0].> and INSPECTION MODE <Ref. to 2-7 [T3E0].>

● **WIRING DIAGRAM:**

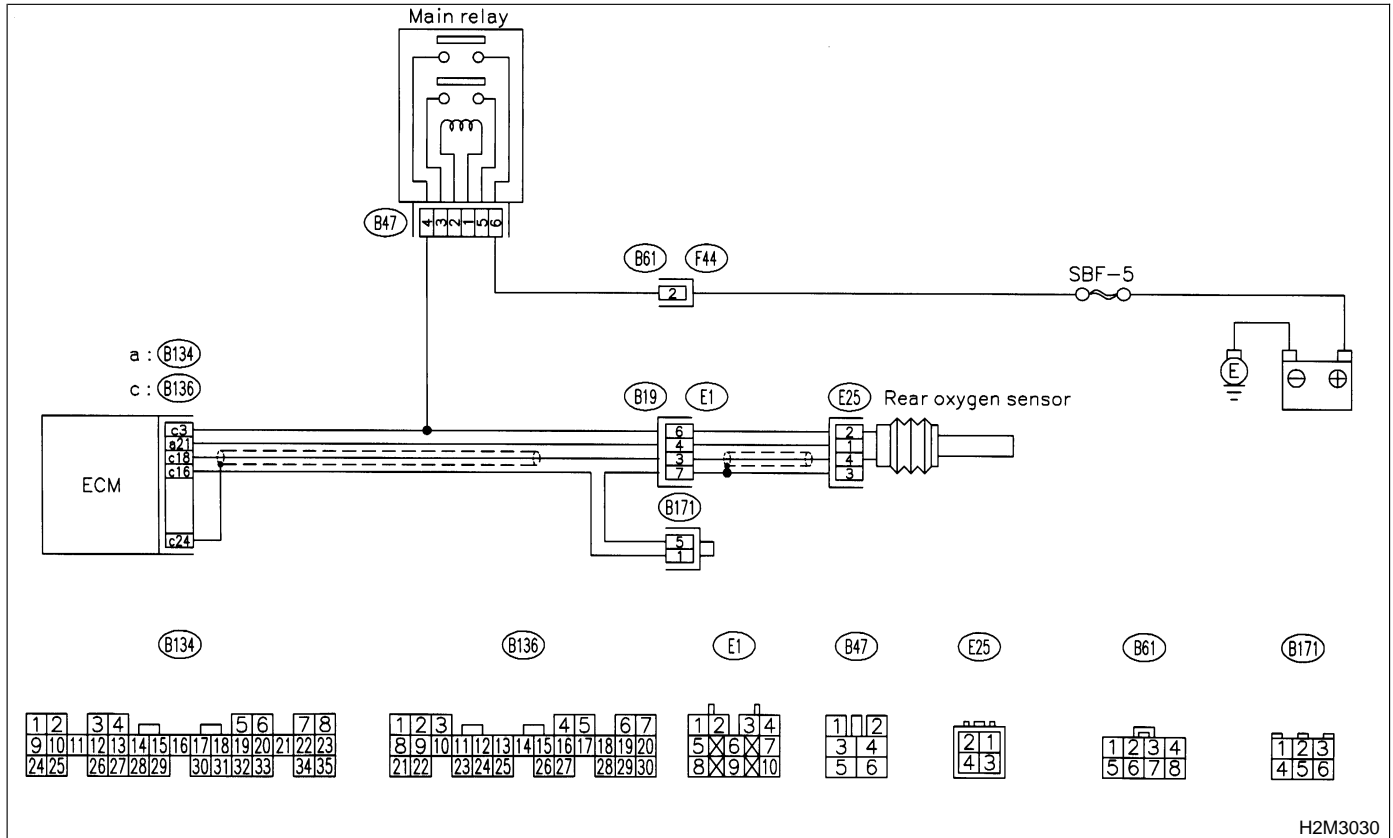

H2M3030

11Q1 : CHECK ANY OTHER DTC ON DISPLAY.

- CHECK** : Does the Subaru Select Monitor or OBD-II general scan tool indicate DTC P0130?
- YES** : Go to step 11Q2.
- NO** : Go to step 11Q3.

11Q2 : CHECK FAILURE CAUSE OF P0130.

Inspect DTC P0130 using "11. Diagnostics Chart with Trouble Code for Except 2200 cc California Spec. Vehicles". <Ref. to 2-7 [T11A0].>

- CHECK** : Is the failure cause of P0130 in the fuel system?
- YES** : Check fuel system.

NOTE:
In this case, it is not necessary to inspect DTC P0136.

- NO** : Go to step 11Q3.

11Q3 : CHECK REAR OXYGEN SENSOR DATA.

- 1) Turn ignition switch to OFF.
- 2) Connect Subaru Select Monitor or OBD-II general scan tool to data link connector.

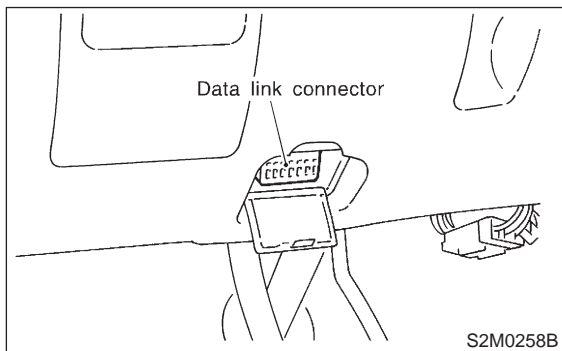

- 3) Start the engine, and turn Subaru Select Monitor or OBD-II general scan tool switch to ON.
- 4) Warm-up the engine until engine coolant temperature is above 70°C (160°F), and keep the engine speed at 2,000 rpm to 3,000 rpm for two minutes.
- 5) Read data of rear oxygen sensor signal using Subaru Select Monitor or OBD-II general scan tool.

NOTE:

- Subaru Select Monitor
For detailed operation procedure, refer to the "READ CURRENT DATA SHOWN ON DISPLAY FOR ENGINE". <Ref. to 2-7 [T3C4].>
- OBD-II general scan tool
For detailed operation procedures, refer to the OBD-II General Scan Tool Instruction Manual.

- CHECK** : **Does the value fluctuate?**
YES : Go to step 11Q7.
NO : Go to step 11Q4.

11Q4 : CHECK REAR OXYGEN SENSOR DATA.

Read data of rear oxygen sensor signal using Subaru Select Monitor or OBD-II General Scan Tool.

- CHECK** : **Is the value fixed between 0.2 and 0.4 V?**
YES : Go to step 11Q5.
NO : Replace rear oxygen sensor. <Ref. to 2-7 [W8A0].>

11Q5 : CHECK HARNESS BETWEEN ECM AND REAR OXYGEN SENSOR CONNECTOR.

- 1) Turn ignition switch to OFF.
- 2) Disconnect connectors from ECM and rear oxygen sensor.
- 3) Measure resistance of harness between ECM and rear oxygen sensor connector.

Connector & terminal

(B136) No. 16 — (E25) No. 3:

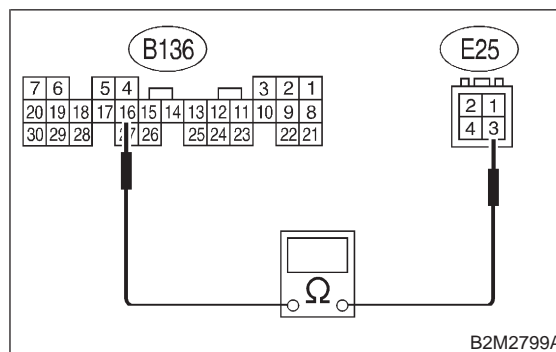

- CHECK** : **Is the resistance more than 3 Ω?**
YES : Repair open circuit in harness between ECM and rear oxygen sensor connector.
NO : Go to step 11Q6.

11Q6 : CHECK HARNESS BETWEEN REAR OXYGEN SENSOR AND ECM CONNECTOR.

- 1) Turn ignition switch to OFF.
- 2) Disconnect connector from rear oxygen sensor.
- 3) Turn ignition switch to ON.
- 4) Measure voltage between rear oxygen sensor harness connector and engine ground or chassis ground.

Connector & terminal

(E25) No. 4 (+) — Engine ground (-):

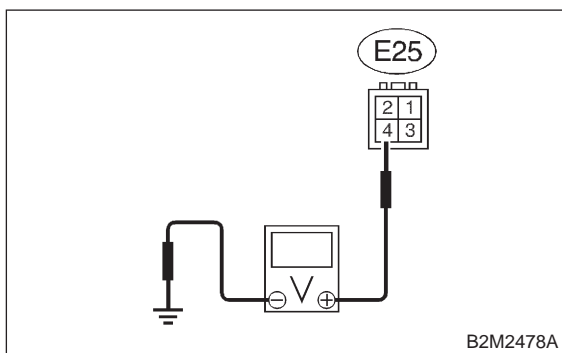

- CHECK** : *Is the voltage more than 0.2 V?*
- YES** : Replace rear oxygen sensor. <Ref. to 2-7 [W8A0].>
- NO** : Repair harness and connector.

NOTE:

In this case, repair the following:

- Open circuit in harness between rear oxygen sensor and ECM connector
- Poor contact in rear oxygen sensor connector
- Poor contact in ECM connector

11Q7 : CHECK EXHAUST SYSTEM.

Check exhaust system parts.

NOTE:

Check the following items.

- Loose installation of portions
- Damage (crack, hole etc.) of parts
- Looseness and ill fitting of parts between front oxygen sensor and rear oxygen sensor

- CHECK** : *Is there a fault in exhaust system?*
- YES** : Repair or replace faulty parts.
- NO** : Replace rear oxygen sensor. <Ref. to 2-7 [W8A0].>

R: DTC P0139 — REAR OXYGEN SENSOR CIRCUIT SLOW RESPONSE —

- **DTC DETECTING CONDITION:**
 - Two consecutive driving cycles with fault

CAUTION:

After repair or replacement of faulty parts, conduct CLEAR MEMORY MODE <Ref. to 2-7 [T3D0].> and INSPECTION MODE <Ref. to 2-7 [T3E0].>

● **WIRING DIAGRAM:**

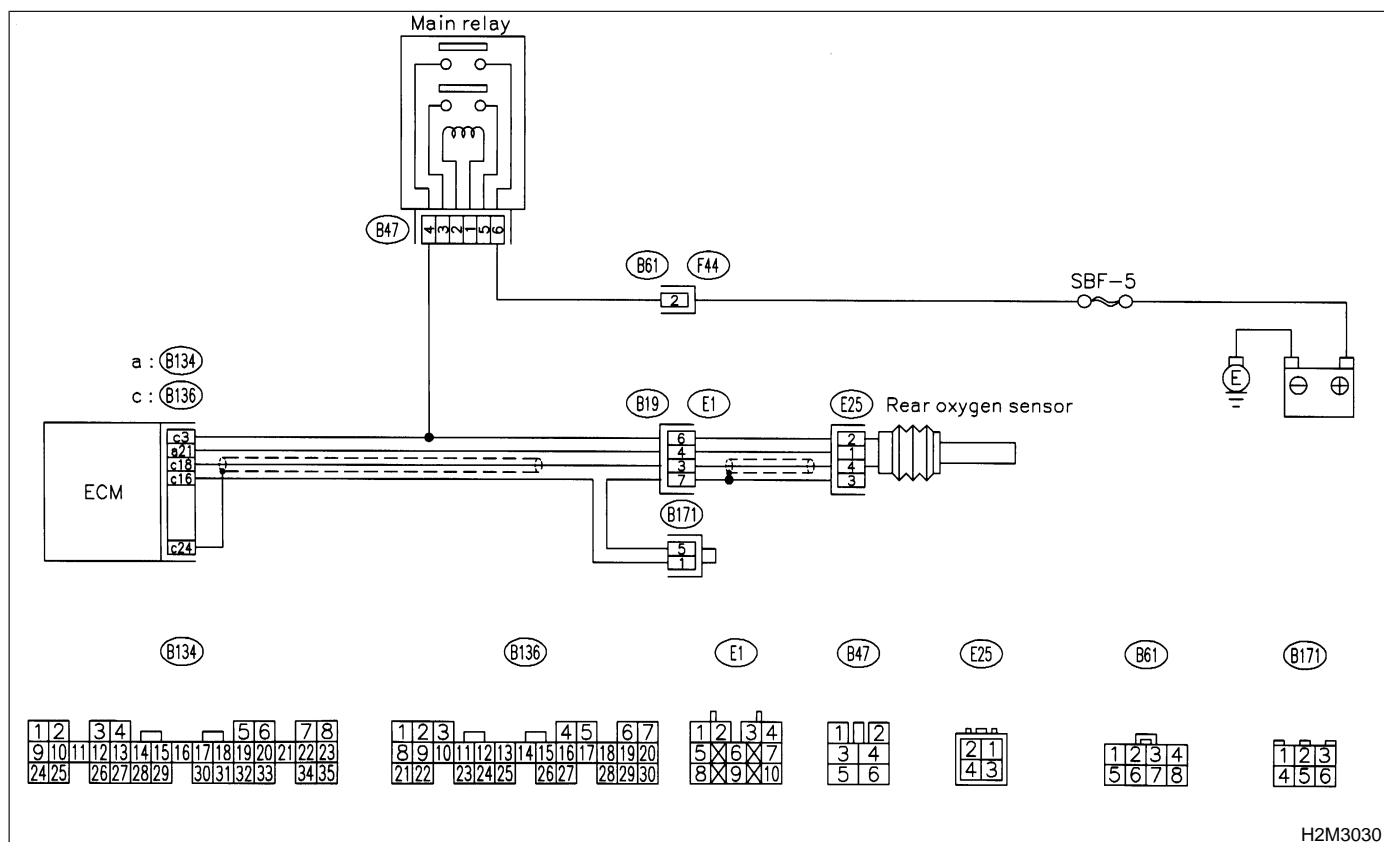

H2M3030

11R1 : CHECK ANY OTHER DTC ON DISPLAY.

CHECK : Does the Subaru Select Monitor or OBD-II general scan tool indicate DTC P0136?

YES : Inspect DTC P0136 using "11. Diagnostics Chart with Trouble Code for Except 2200 cc California Spec. Vehicles". <Ref. to 2-7 [T11A0].>

NOTE:
In this case, it is not necessary to inspect DTC P0139.

NO : Replace rear oxygen sensor. <Ref. to 2-7 [W8A0].>

S: DTC P0141 — REAR OXYGEN SENSOR HEATER CIRCUIT MALFUNCTION

- **DTC DETECTING CONDITION:**
 - Two consecutive driving cycles with fault

CAUTION:

After repair or replacement of faulty parts, conduct CLEAR MEMORY MODE <Ref. to 2-7 [T3D0].> and INSPECTION MODE <Ref. to 2-7 [T3E0].>

● **WIRING DIAGRAM:**

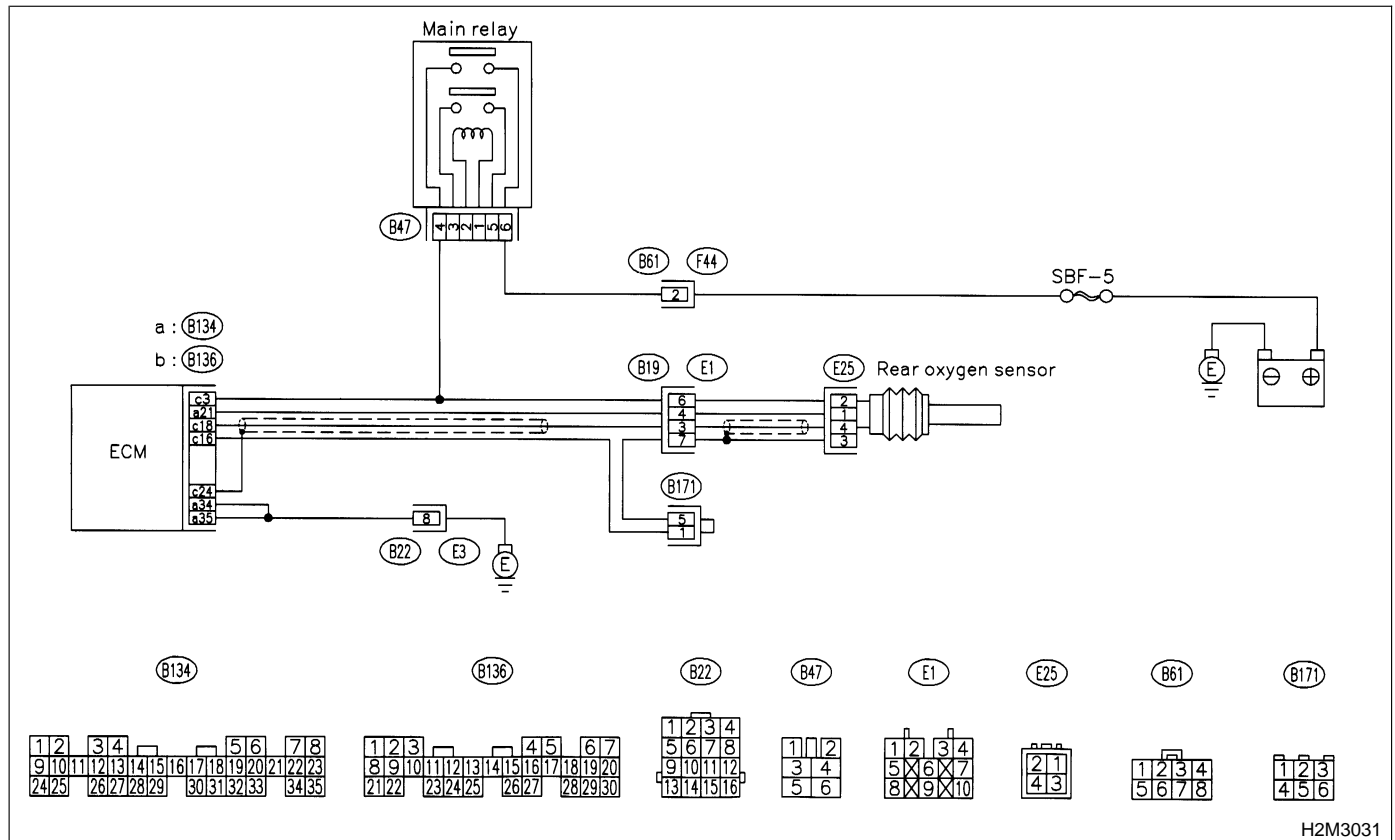

11S1 : CHECK ANY OTHER DTC ON DISPLAY.

- CHECK** : Does the Subaru Select Monitor or OBD-II general scan tool indicate DTC P0141 and P0135 at the same time?
- YES** : Go to step 11S2.
- NO** : Go to step 11S3.

2-7 [T11S2]

ON-BOARD DIAGNOSTICS II SYSTEM

11. Diagnostics Chart with Trouble Code for Except 2200 cc California Spec. Vehicles

11S2 : CHECK GROUND CIRCUIT OF ECM.

- 1) Turn ignition switch to OFF.
- 2) Disconnect connector from ECM.
- 3) Measure resistance of harness between ECM connector and chassis ground.

Connector & terminal

(B134) No. 35 — Chassis ground:

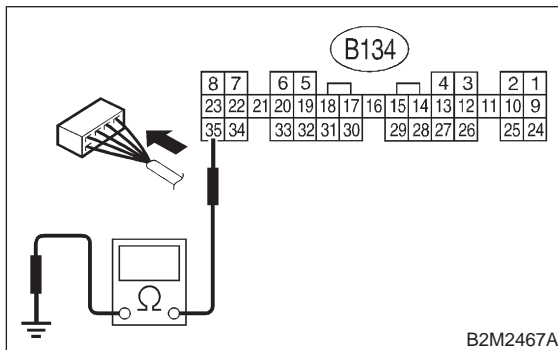

- CHECK** : Is the resistance less than 5 Ω?
- YES** : Go to step 11S4.
- NO** : Go to step 11S3.

11S3 : CHECK GROUND CIRCUIT OF ECM.

- 1) Repair harness and connector.

NOTE:

In this case, repair the following:

- Open circuit in harness between ECM and engine ground terminal
- Poor contact in ECM connector
- Poor contact in coupling connector (B22)

- 2) Measure resistance of harness between ECM connector and chassis ground.

Connector & terminal

(B134) No. 34 — Chassis ground:

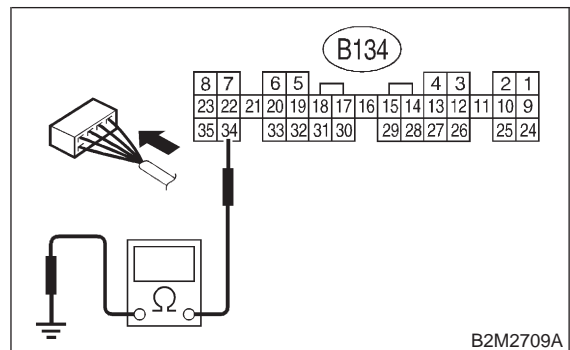

- CHECK** : Is the resistance less than 5 Ω?
- YES** : Go to step 11S4.
- NO** : Repair harness and connector.

NOTE:

In this case, repair the following:

- Open circuit in harness between ECM and engine ground terminal
- Poor contact in ECM connector
- Poor contact in coupling connector (B22)

11S4 : CONNECT SUBARU SELECT MONITOR OR THE OBD-II GENERAL SCAN TOOL, AND READ DATA.

- 1) Turn ignition switch to OFF.
- 2) Connect Subaru Select Monitor or the OBD-II general scan tool to data link connector.

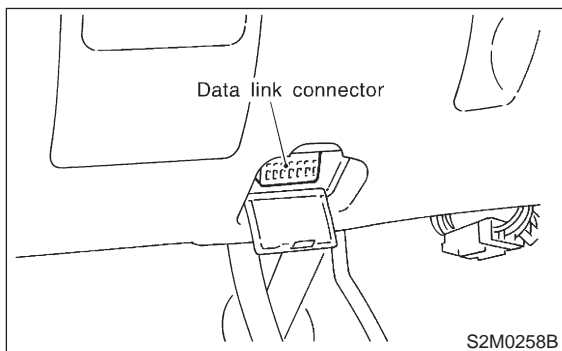

- 3) Turn ignition switch to ON and Subaru Select Monitor or OBD-II general scan tool switch to ON.
- 4) Start engine.
- 5) Read data of rear oxygen sensor heater current using Subaru Select Monitor or OBD-II general scan tool.

NOTE:

- Subaru Select Monitor
For detailed operation procedure, refer to the "READ CURRENT DATA SHOWN ON DISPLAY FOR ENGINE". <Ref. to 2-7 [T3C4].>
- OBD-II scan tool
For detailed operation procedures, refer to the OBD-II General Scan Tool Instruction Manual.

CHECK : *Is the value more than 0.2 A?*

YES : Repair connector.

NOTE:

In this case, repair the following:

- Poor contact in rear oxygen sensor connector
- Poor contact in rear oxygen sensor connecting harness connector
- Poor contact in ECM connector

NO : Go to step 11S5.

11S5 : CHECK OUTPUT SIGNAL FROM ECM.

- 1) Start and idle the engine.
- 2) Measure voltage between ECM connector and chassis ground.

Connector & terminal

(B134) No. 21 (+) — Chassis ground (-):

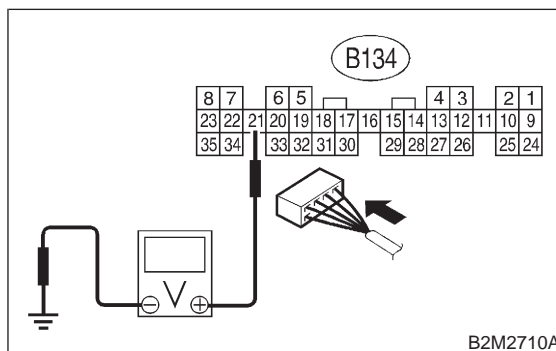

CHECK : *Is the voltage less than 1.0 V?*

YES : Go to step 11S8.

NO : Go to step 11S6.

11S6 : CHECK OUTPUT SIGNAL FROM ECM.

Measure voltage between ECM connector and chassis ground.

Connector & terminal

(B134) No. 21 (+) — Chassis ground (-):

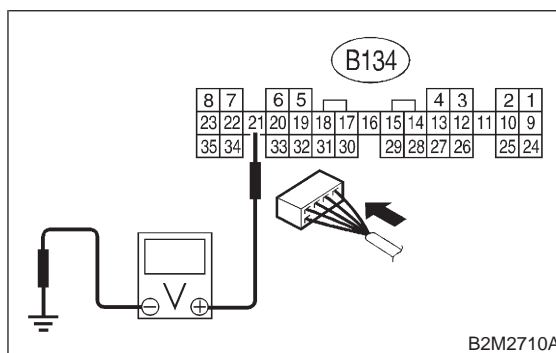

CHECK : *Does the voltage change less than 1.0 V by shaking harness and connector of ECM while monitoring the value with voltage meter?*

YES : Repair poor contact in ECM connector.

NO : Go to step 11S7.

2-7 [T11S7]

ON-BOARD DIAGNOSTICS II SYSTEM

11. Diagnostics Chart with Trouble Code for Except 2200 cc California Spec. Vehicles

11S7 : CHECK OUTPUT SIGNAL FROM ECM.

- 1) Disconnect connector from rear oxygen sensor.
- 2) Measure voltage between ECM connector and chassis ground.

Connector & terminal

(B134) No. 21 (+) — Chassis ground (-):

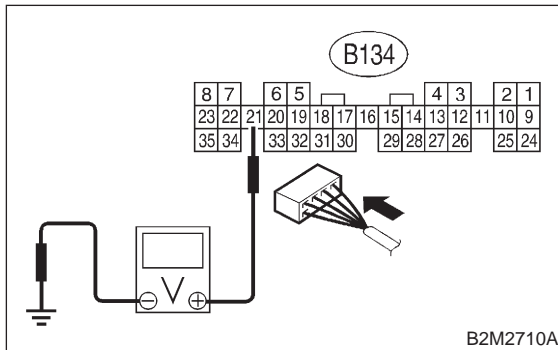

- CHECK** : *Is the voltage less than 1.0 V?*
- YES** : Replace ECM. <Ref. to 2-7 [W15A0].>
- NO** : Repair battery short circuit in harness between ECM and rear oxygen sensor connector. After repair, replace ECM. <Ref. to 2-7 [W15A0].>

11S8 : CHECK POWER SUPPLY TO REAR OXYGEN SENSOR.

- 1) Turn ignition switch to OFF.
- 2) Disconnect connector from rear oxygen sensor.
- 3) Turn ignition switch to ON.
- 4) Measure voltage between rear oxygen sensor connector and engine ground or chassis ground.

Connector & terminal

(E25) No. 2 (+) — Chassis ground (-):

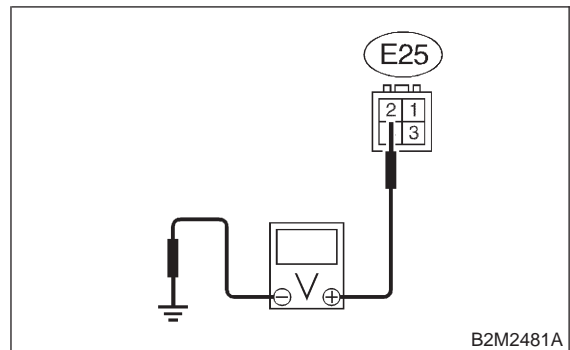

- CHECK** : *Is the voltage more than 10 V?*
- YES** : Go to step 11S9.
- NO** : Repair power supply line.

NOTE:

In this case, repair the following:

- Open circuit in harness between main relay and rear oxygen sensor connector
- Poor contact in rear oxygen sensor connector
- Poor contact in coupling connector (E1)

11S9 : CHECK REAR OXYGEN SENSOR.

- 1) Turn ignition switch to OFF.
- 2) Measure resistance between rear oxygen sensor connector terminals.

Terminals

No. 1 — No. 2:

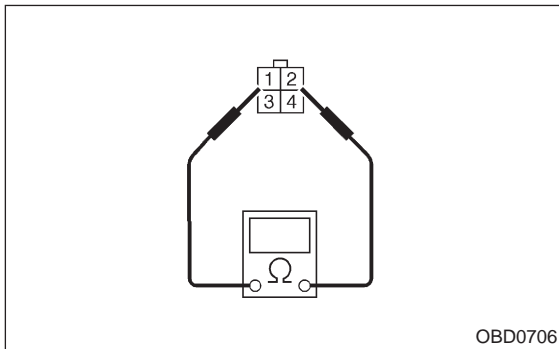

CHECK : *Is the resistance less than 30 Ω?*

YES : Repair harness and connector.

NOTE:

In this case, repair the following:

- Open circuit in harness between rear oxygen sensor and ECM connector
- Poor contact in rear oxygen sensor connector
- Poor contact in ECM connector
- Poor contact in coupling connector (E1)

NO : Replace rear oxygen sensor. <Ref. to 2-7 [W8A0].>

MEMO:

T: DTC P0170 — FUEL TRIM MALFUNCTION —

- **DTC DETECTING CONDITION:**
 - Two consecutive driving cycles with fault
- **TROUBLE SYMPTOM:**
 - Erroneous idling
 - Engine stalls.
 - Poor driving performance

CAUTION:

After repair or replacement of faulty parts, conduct **CLEAR MEMORY MODE** <Ref. to 2-7 [T3D0].> and **INSPECTION MODE** <Ref. to 2-7 [T3E0].>

11T1 : CHECK EXHAUST SYSTEM.

- CHECK** : Are there holes or loose bolts on exhaust system?
- YES** : Repair exhaust system.
- NO** : Go to step 11T2.

11T2 : CHECK AIR INTAKE SYSTEM.

- CHECK** : Are there holes, loose bolts or disconnection of hose on air intake system?
- YES** : Repair air intake system.
- NO** : Go to step 11T3.

11T3 : CHECK FUEL PRESSURE.

- 1) Release fuel pressure.
- (1) Remove fuel pump access hole lid located on the right rear of trunk compartment floor (Sedan) or luggage compartment floor (Wagon).

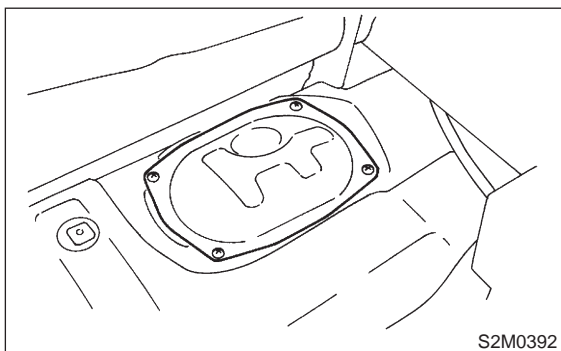

- (2) Disconnect connector from fuel tank.

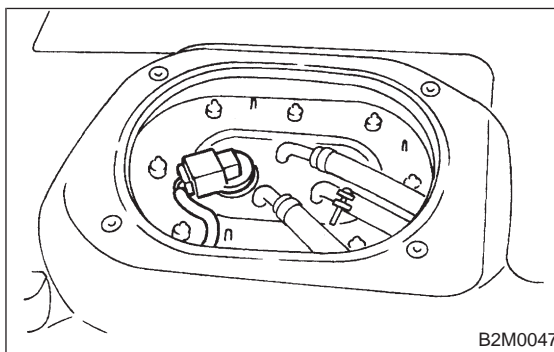

- (3) Start the engine, and run it until it stalls.
- (4) After stopping the engine, crank the engine for 5 to 7 seconds to reduce fuel pressure.
- (5) Turn ignition switch to OFF.
- (6) Remove fuel filler cap.
- 2) Connect connector to fuel tank.

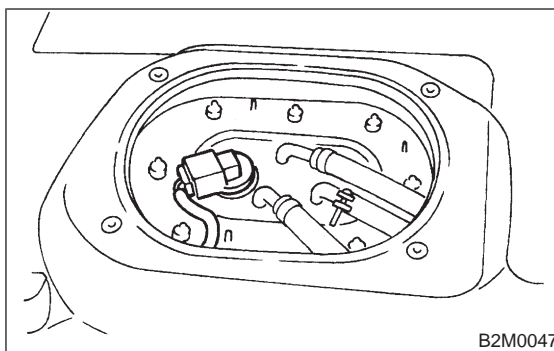

- 3) Disconnect fuel delivery hose from fuel filter, and connect fuel pressure gauge.

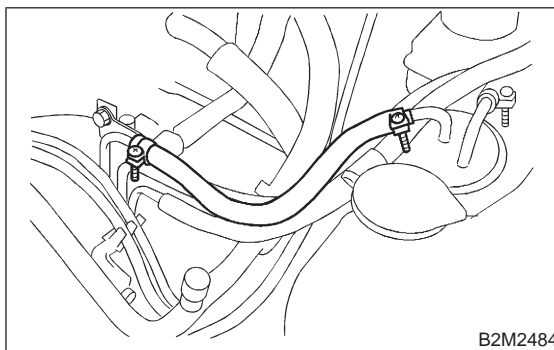

- 4) Install fuel filler cap.

2-7 [T11T4]

ON-BOARD DIAGNOSTICS II SYSTEM

11. Diagnostics Chart with Trouble Code for Except 2200 cc California Spec. Vehicles

5) Start the engine and idle while gear position is neutral.

6) Measure fuel pressure while disconnecting pressure regulator vacuum hose from intake manifold.

WARNING:

Before removing fuel pressure gauge, release fuel pressure.

NOTE:

If fuel pressure does not increase, squeeze fuel return hose 2 to 3 times, then measure fuel pressure again.

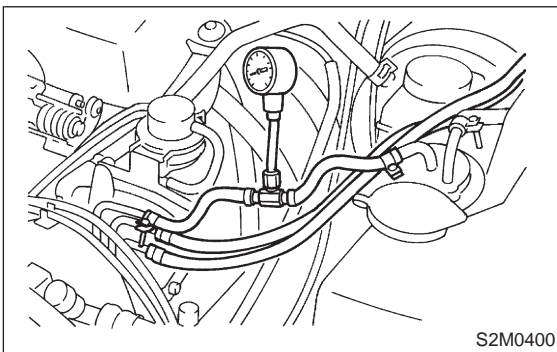

CHECK : *Is fuel pressure between 284 and 314 kPa (2.9 — 3.2 kg/cm², 41 — 46 psi)?*

YES : Go to step 11T4.

NO : Repair the following items.

Fuel pressure too high	<ul style="list-style-type: none"> ● Clogged fuel return line or bent hose
Fuel pressure too low	<ul style="list-style-type: none"> ● Improper fuel pump discharge ● Clogged fuel supply line

11T4 : CHECK FUEL PRESSURE.

After connecting pressure regulator vacuum hose, measure fuel pressure.

WARNING:

Before removing fuel pressure gauge, release fuel pressure.

NOTE:

● If fuel pressure does not increase, squeeze fuel return hose 2 to 3 times, then measure fuel pressure again.

● If out of specification as measured at this step, check or replace pressure regulator and pressure regulator vacuum hose.

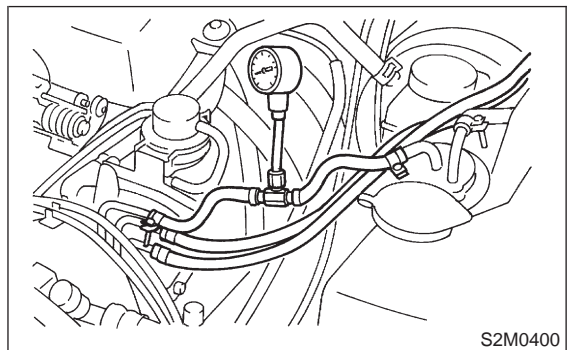

CHECK : *Is fuel pressure between 206 and 235 kPa (2.1 — 2.4 kg/cm², 30 — 34 psi)?*

YES : Go to step 11T5.

NO : Repair the following items.

Fuel pressure too high	<ul style="list-style-type: none"> ● Faulty pressure regulator ● Clogged fuel return line or bent hose
Fuel pressure too low	<ul style="list-style-type: none"> ● Faulty pressure regulator ● Improper fuel pump discharge ● Clogged fuel supply line

NOTE:

The fuel pressure gauge registers 10 to 20 kPa (0.1 to 0.2 kg/cm², 1.4 to 2.8 psi) higher than standard values during high-altitude operations.

11T5 : CHECK ENGINE COOLANT TEMPERATURE SENSOR. < REF. TO 2-7 [T11H0].> OR <REF. TO 2-7 [T11I0].>

- 1) Turn ignition switch to OFF.
- 2) Connect the Subaru Select Monitor or the OBD-II general scan tool to data link connector.

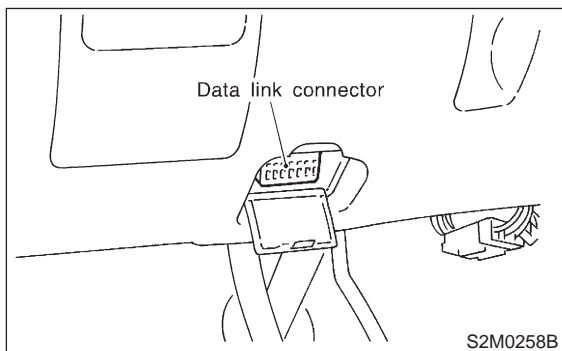

- 3) Start the engine and warm-up completely.
- 4) Read data of engine coolant temperature sensor signal using Subaru Select Monitor or OBD-II general scan tool.

NOTE:

- Subaru Select Monitor
For detailed operation procedure, refer to the "READ CURRENT DATA SHOWN ON DISPLAY FOR ENGINE". <Ref. to 2-7 [T3C4].>
- OBD-II general scan tool
For detailed operation procedures, refer to the OBD-II General Scan Tool Instruction Manual.

- CHECK** : *Is temperature greater than 60°C (140°F)?*
- YES** : Go to step 11T6.
- NO** : Replace engine coolant temperature sensor. <Ref. to 2-7 [W5A2].>

11T6 : CHECK MASS AIR FLOW SENSOR.

- 1) Start the engine and warm-up engine until coolant temperature is greater than 60°C (140°F).
- 2) Place the selector lever in "N" or "P" position.
- 3) Turn A/C switch to OFF.
- 4) Turn all accessory switches to OFF.
- 5) Read data of mass flow sensor signal using Subaru Select Monitor or OBD-II general scan tool.

NOTE:

- Subaru Select Monitor
For detailed operation procedure, refer to the "READ CURRENT DATA SHOWN ON DISPLAY FOR ENGINE". <Ref. to 2-7 [T3C4].>
- OBD-II general scan tool
For detailed operation procedures, refer to the OBD-II General Scan Tool Instruction Manual.

Specification:

Engine speed	Specified value
Idling	2.2 — 4.2 (g/sec)
2,500 rpm	8.6 — 14.5 (g/sec)

- CHECK** : *Is the voltage within the specifications?*
- YES** : Contact with SOA service.
- NOTE:**
Inspection by DTM is required, because probable cause is deterioration of multiple parts.
- NO** : Replace mass air flow sensor. <Ref. to 2-7 [W2A0].>

U: DTC P0181 — FUEL TEMPERATURE SENSOR A CIRCUIT RANGE/PERFORMANCE PROBLEM —

- **DTC DETECTING CONDITION:**
 - Two consecutive driving cycles with fault

CAUTION:

After repair or replacement of faulty parts, conduct **CLEAR MEMORY MODE** <Ref. to 2-7 [T3D0].> and **INSPECTION MODE** <Ref. to 2-7 [T3E0].>

- **WIRING DIAGRAM:**

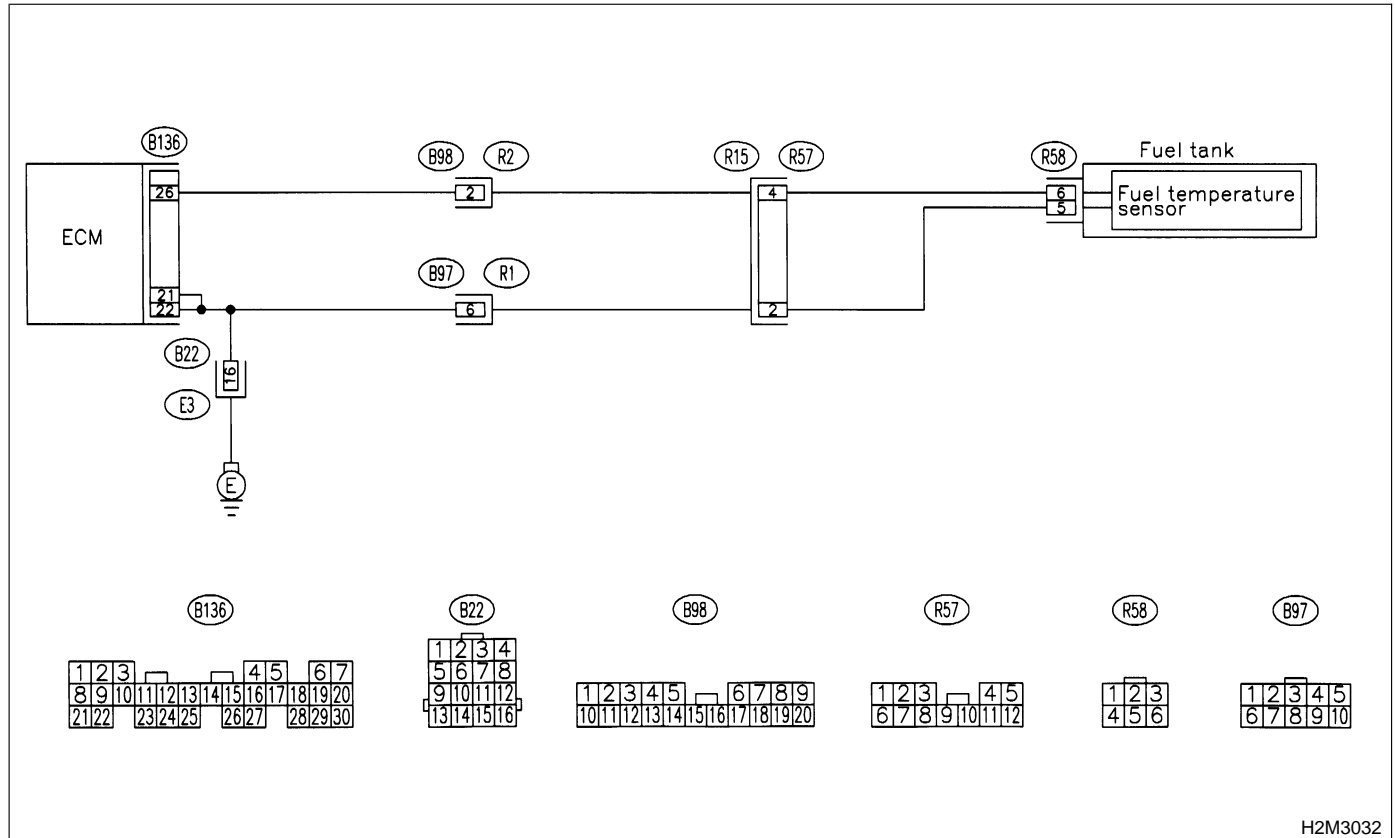

H2M3032

11U1 : CHECK ANY OTHER DTC ON DISPLAY.

- CHECK** : Does the Subaru Select Monitor or OBD-II general scan tool indicate DTC P0182 or P0183?
- YES** : Inspect DTC P0182 or P0183 using "11. Diagnostics Chart with Trouble Code for Except 2200 cc California Spec. Vehicles". <Ref. to 2-7 [T11A0].>

NOTE:

In this case, it is not necessary to inspect DTC P0181.

- NO** : Replace fuel temperature sensor. <Ref. to 2-1 [W5A0].>

V: DTC P0182 — FUEL TEMPERATURE SENSOR A CIRCUIT LOW INPUT —

- DTC DETECTING CONDITION:
 - Immediately at fault recognition

CAUTION:

After repair or replacement of faulty parts, conduct CLEAR MEMORY MODE <Ref. to 2-7 [T3D0].> and INSPECTION MODE <Ref. to 2-7 [T3E0].>

- WIRING DIAGRAM:

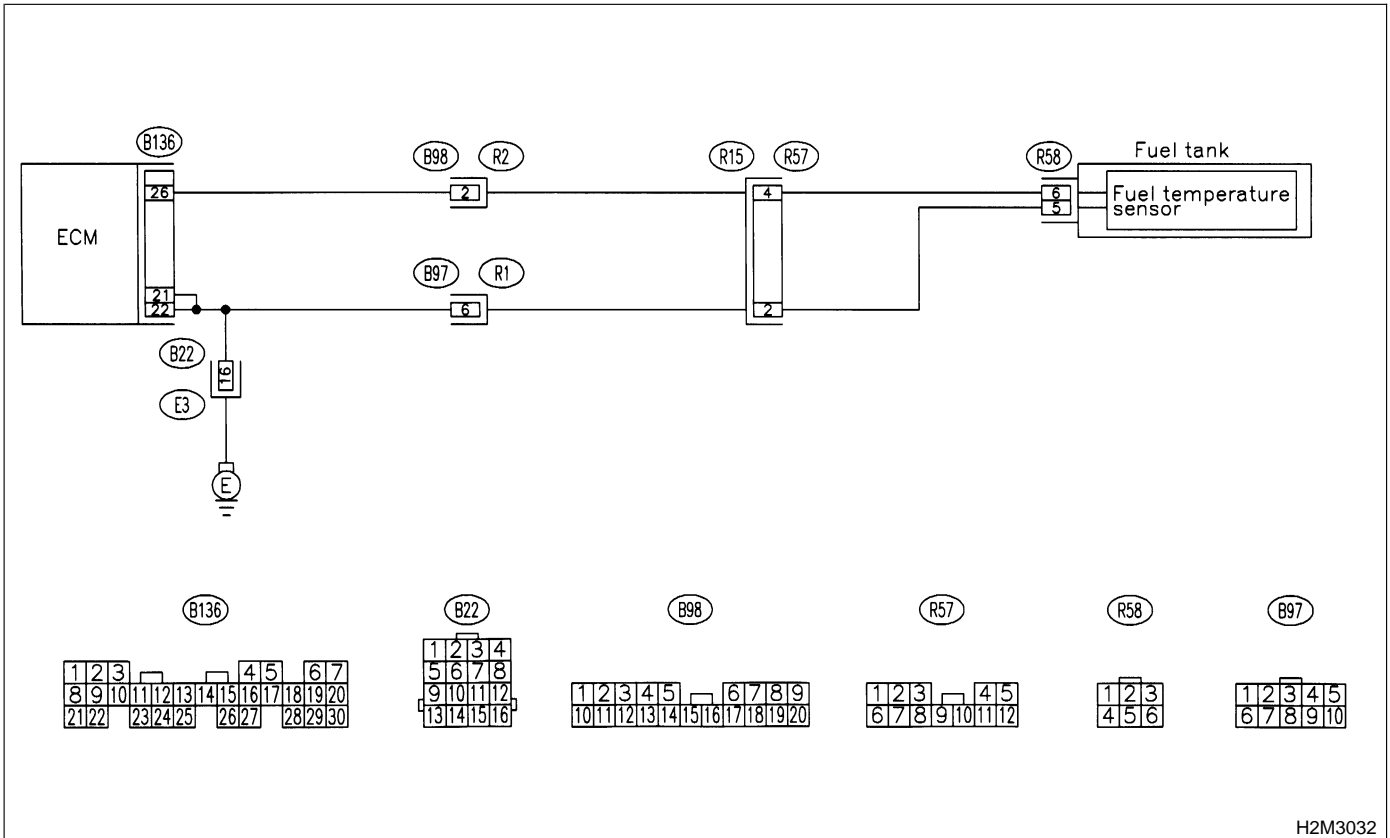

H2M3032

11V1 : CONNECT SUBARU SELECT MONITOR OR THE OBD-II GENERAL SCAN TOOL, AND READ DATA.

- 1) Turn ignition switch to OFF.
- 2) Connect Subaru Select Monitor or the OBD-II general scan tool to data link connector.

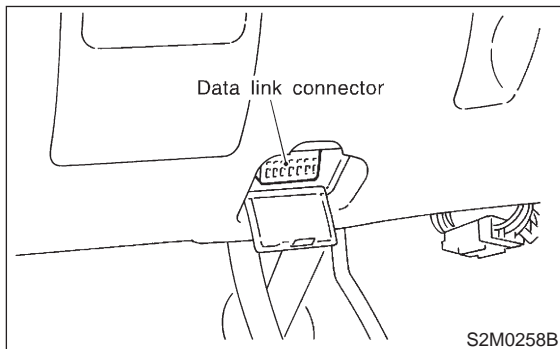

- 3) Turn ignition switch to ON and Subaru Select Monitor or OBD-II general scan tool switch to ON.
- 4) Start engine.
- 5) Read data of fuel temperature sensor signal using Subaru Select Monitor or OBD-II general scan tool.

NOTE:

● Subaru Select Monitor

For detailed operation procedure, refer to the "READ CURRENT DATA SHOWN ON DISPLAY FOR ENGINE". <Ref. to 2-7 [T3C4].>

● OBD-II general scan tool

For detailed operation procedures, refer to the OBD-II General Scan Tool Instruction Manual.

CHECK : *Is the value greater than 150°C (300°F)?*

YES : Go to step 11V2.

NO : Even if MIL lights up, the circuit has returned to a normal condition at this time.

11V2 : CHECK HARNESS BETWEEN FUEL TEMPERATURE SENSOR AND ECM CONNECTOR.

- 1) Turn ignition switch to OFF.
- 2) Remove access hole lid.

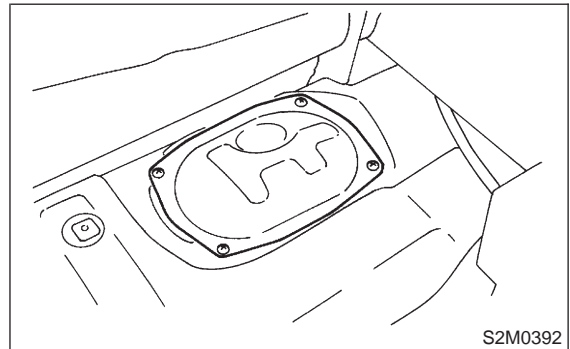

- 3) Disconnect connector from fuel pump.
- 4) Connect Subaru Select Monitor or the OBD-II general scan tool to data link connector.

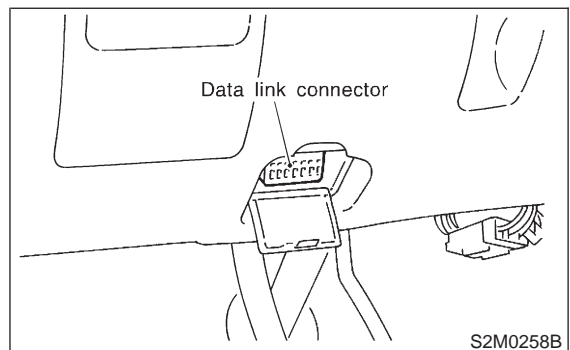

- 5) Turn ignition switch and Subaru Select Monitor or OBD-II general scan tool switch to ON.
- 6) Read data of fuel temperature sensor signal using Subaru Select Monitor or the OBD-II general scan tool.

NOTE:

● Subaru Select Monitor

For detailed operation procedure, refer to the "READ CURRENT DATA SHOWN ON DISPLAY FOR ENGINE". <Ref. to 2-7 [T3C4].>

● OBD-II general scan tool

For detailed operation procedures, refer to the OBD-II General Scan Tool Instruction Manual.

CHECK : *Is the value less than -40°C (-40°F)?*

YES : Replace fuel temperature sensor. <Ref. to 2-1 [W5A0].>

NO : Repair ground short circuit in harness between fuel pump and ECM connector.

W: DTC P0183 — FUEL TEMPERATURE SENSOR A CIRCUIT HIGH INPUT —

- **DTC DETECTING CONDITION:**
 - Immediately at fault recognition

CAUTION:

After repair or replacement of faulty parts, conduct CLEAR MEMORY MODE <Ref. to 2-7 [T3D0].> and INSPECTION MODE <Ref. to 2-7 [T3E0].>

● **WIRING DIAGRAM:**

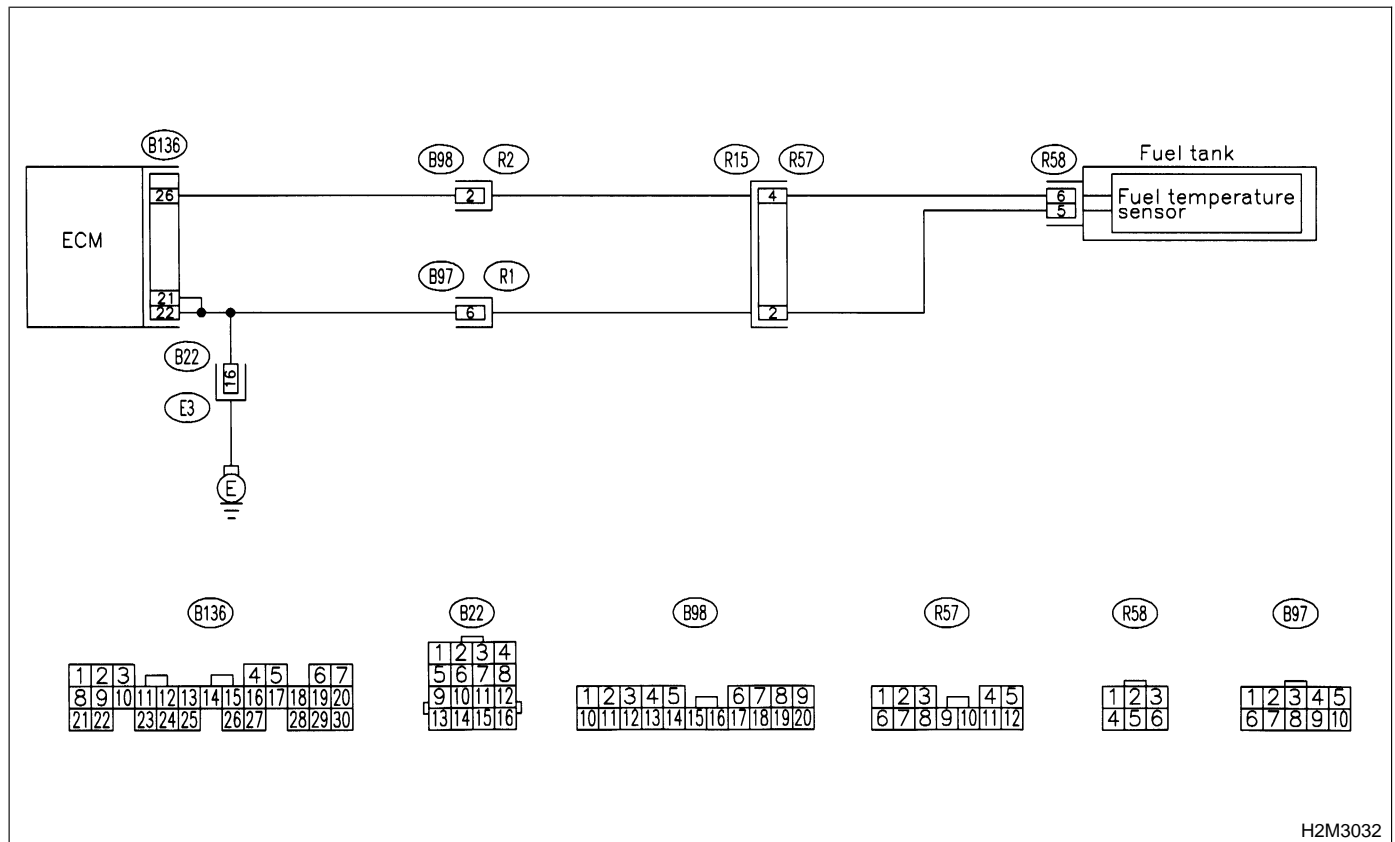

H2M3032

2-7 [T11W1]

ON-BOARD DIAGNOSTICS II SYSTEM

11. Diagnostics Chart with Trouble Code for Except 2200 cc California Spec. Vehicles

11W1 : CONNECT SUBARU SELECT MONITOR OR THE OBD-II GENERAL SCAN TOOL, AND READ DATA.

- 1) Turn ignition switch to OFF.
- 2) Connect Subaru Select Monitor or the OBD-II general scan tool to data link connector.

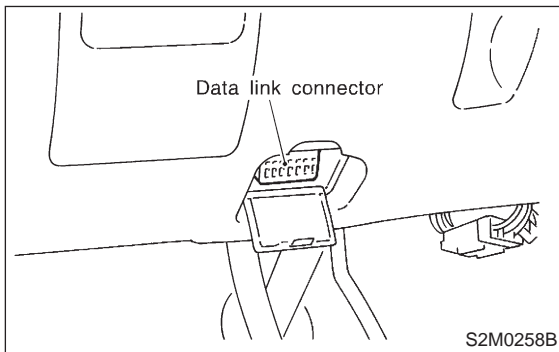

- 3) Turn ignition switch to ON and Subaru Select Monitor or OBD-II general scan tool switch to ON.
- 4) Start engine.
- 5) Read data of fuel temperature sensor signal using Subaru Select Monitor or OBD-II general scan tool.

NOTE:

- Subaru Select Monitor
For detailed operation procedure, refer to the "READ CURRENT DATA SHOWN ON DISPLAY FOR ENGINE". <Ref. to 2-7 [T3C4].>
- OBD-II general scan tool
For detailed operation procedures, refer to the OBD-II General Scan Tool Instruction Manual.

CHECK : *Is the value less than -40°C (-40°F)?*

YES : Go to step 11W2.

NO : Repair poor contact.

NOTE:

In this case, repair the following:

- Poor contact in fuel pump connector
- Poor contact in ECM connector
- Poor contact in coupling connectors (B22), (B98), (B97) and (R57)

11W2 : CHECK HARNESS BETWEEN FUEL TEMPERATURE SENSOR AND ECM CONNECTOR.

- 1) Turn ignition switch to OFF.
- 2) Remove access hole lid.

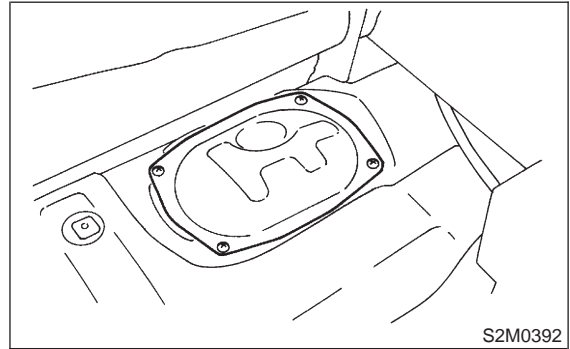

- 3) Disconnect connector from fuel pump.
- 4) Measure voltage between fuel pump connector and chassis ground.

Connector & terminal

(R58) No. 6 (+) — Chassis ground (-):

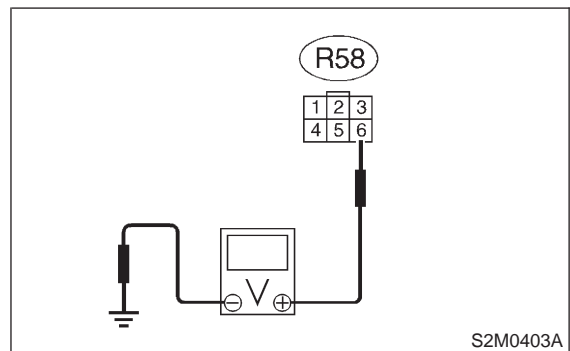

CHECK : *Is the voltage more than 10 V?*

YES : Repair battery short circuit in harness between ECM and fuel pump connector.

NO : Go to step 11W3.

11W3 : CHECK HARNESS BETWEEN FUEL TEMPERATURE SENSOR AND ECM CONNECTOR.

- 1) Turn ignition switch to ON.
- 2) Measure voltage between fuel pump connector and chassis ground.

Connector & terminal
(R58) No. 6 (+) — Chassis ground (-):

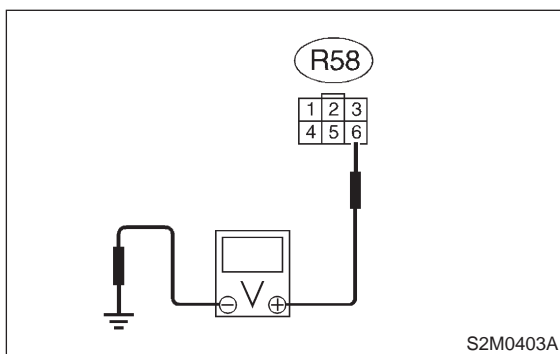

- CHECK** : **Is the voltage more than 10 V?**
- YES** : Repair battery short circuit in harness between ECM and fuel pump connector.
- NO** : Go to step **11W4**.

11W4 : CHECK HARNESS BETWEEN FUEL TEMPERATURE SENSOR AND ECM CONNECTOR.

Measure voltage between fuel pump connector and chassis ground.

Connector & terminal
(R58) No. 6 (+) — Chassis ground (-):

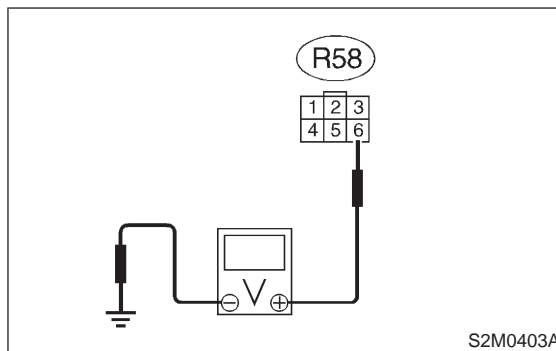

- CHECK** : **Is the voltage more than 4 V?**
- YES** : Go to step **11W5**.
- NO** : Repair harness and connector.

NOTE:

- In this case, repair the following:
- Open circuit in harness between ECM and fuel pump connector
 - Poor contact in fuel pump connector
 - Poor contact in ECM connector
 - Poor contact in coupling connectors (B98) and (R57)

11W5 : CHECK HARNESS BETWEEN FUEL TEMPERATURE SENSOR AND ECM CONNECTOR.

- 1) Turn ignition switch to OFF.
- 2) Measure resistance of harness between fuel pump connector and chassis ground.

Connector & terminal

(R58) No. 5 — Chassis ground:

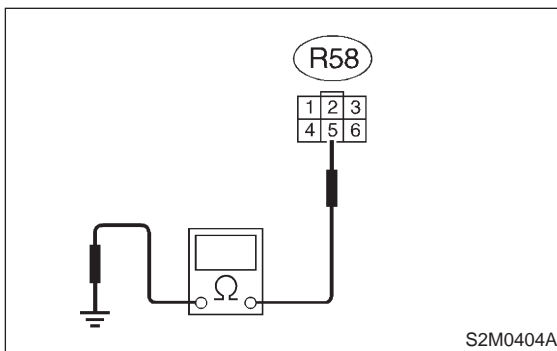

CHECK : **Is the resistance less than 5 Ω?**

YES : Replace fuel temperature sensor. <Ref. to 2-1 [W5A0].>

NO : Repair harness and connector.

NOTE:

In this case, repair the following:

- Open circuit in harness between ECM and fuel pump connector
- Poor contact in fuel pump connector
- Poor contact in ECM connector
- Poor contact in coupling connectors (B22), (B97) and (R57)

X: DTC P0301 — CYLINDER 1 MISFIRE DETECTED —

NOTE:

For the diagnostic procedure, refer to 2-7 [T14AA1]. <Ref. to 2-7 [T11AA0].>

Y: DTC P0302 — CYLINDER 2 MISFIRE DETECTED —

NOTE:

For the diagnostic procedure, refer to 2-7 [T14AA1]. <Ref. to 2-7 [T11AA0].>

Z: DTC P0303 — CYLINDER 3 MISFIRE DETECTED —

NOTE:

For the diagnostic procedure, refer to 2-7 [T14AA1]. <Ref. to 2-7 [T11AA0].>

AA: DTC P0304 — CYLINDER 4 MISFIRE DETECTED —

• DTC DETECTING CONDITION:

- Two consecutive driving cycles with fault
- Immediately at fault recognition (A misfire which could damage catalyst occurs.)

• TROUBLE SYMPTOM:

- Engine stalls.
- Erroneous idling
- Rough driving

CAUTION:

After repair or replacement of faulty parts, conduct CLEAR MEMORY MODE <Ref. to 2-7 [T3D0].> and INSPECTION MODE <Ref. to 2-7 [T3E0].>

• WIRING DIAGRAM:

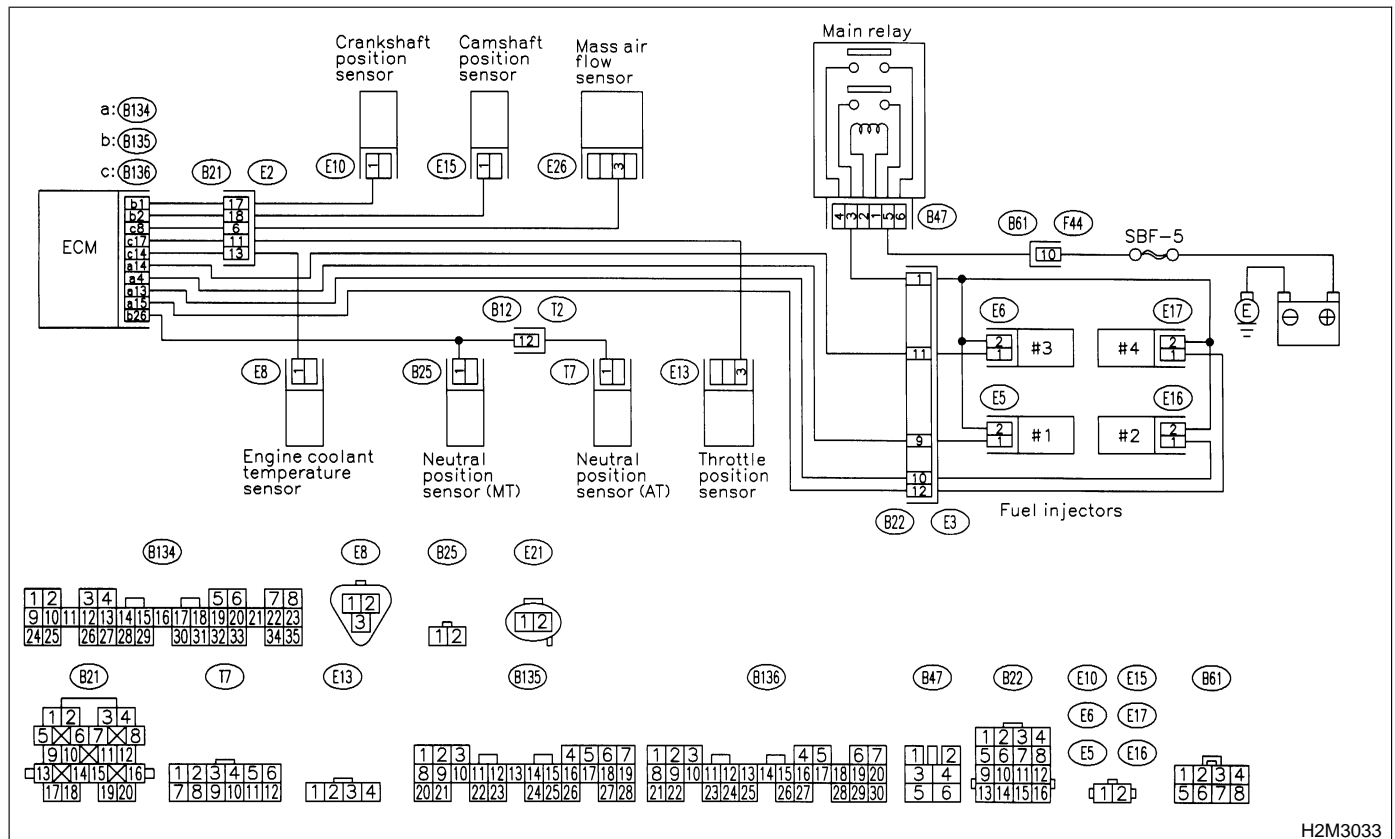

H2M3033

11AA1 : CHECK ANY OTHER DTC ON DISPLAY.

CHECK : Does the Subaru Select Monitor or OBD-II general scan tool indicate DTC P0101, P0102, P0103, P0116, P0117 or P0125?

YES : Inspect DTC P0101, P0102, P0103, P0116, P0117 or P0125 using "11. Diagnostics Chart with Trouble Code for Except 2200 cc California Spec. Vehicles". <Ref. to 2-7 [T11A0].>

NOTE:

In this case, it is not necessary to inspect DTC P0301, P0302, P0303 and P0304.

NO : Go to step 11AA2.

11AA2 : CHECK OUTPUT SIGNAL FROM ECM.

- 1) Turn ignition switch to ON.
- 2) Measure voltage between ECM connector and chassis ground on faulty cylinders.

Connector & terminal

- #1; (B134) No. 4 (+) — Chassis ground (-):
- #2; (B134) No. 13 (+) — Chassis ground (-):
- #3; (B134) No. 14 (+) — Chassis ground (-):
- #4; (B134) No. 15 (+) — Chassis ground (-):

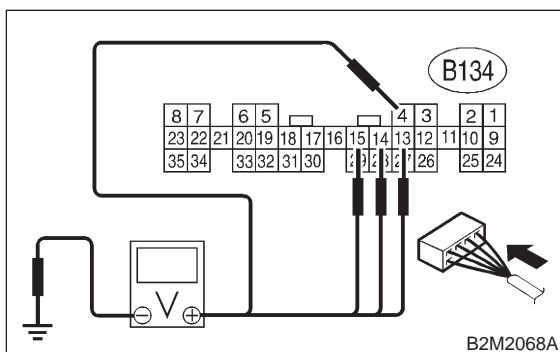

- CHECK** : Is the voltage more than 10 V?
- YES** : Go to step 11AA7.
- NO** : Go to step 11AA3.

11AA3 : CHECK HARNESS BETWEEN FUEL INJECTOR AND ECM CONNECTOR.

- 1) Turn ignition switch to OFF.
- 2) Disconnect connector from fuel injector on faulty cylinders.
- 3) Measure voltage between ECM connector and engine ground on faulty cylinders.

Connector & terminal

- #1; (E5) No. 1 — Engine ground:
- #2; (E16) No. 1 — Engine ground:
- #3; (E6) No. 1 — Engine ground:
- #4; (E17) No. 1 — Engine ground:

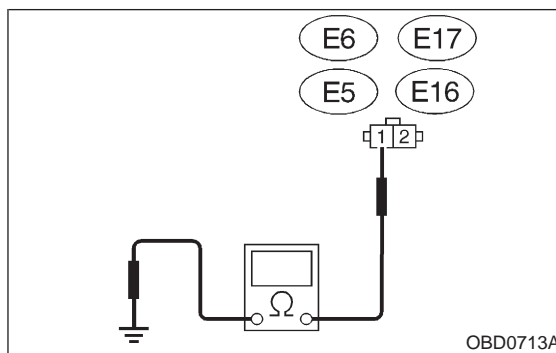

- CHECK** : Is the resistance less than 10 Ω?
- YES** : Repair ground short circuit in harness between fuel injector and ECM connector.
- NO** : Go to step 11AA4.

11AA4 : CHECK HARNESS BETWEEN FUEL INJECTOR AND ECM CONNECTOR.

Measure resistance of harness connector between ECM connector and fuel injector on faulty cylinders.

Connector & terminal

- #1; (B134) No. 4 — (E5) No. 1:
- #2; (B134) No. 13 — (E16) No. 1:
- #3; (B134) No. 14 — (E6) No. 1:
- #4; (B134) No. 15 — (E17) No. 1:

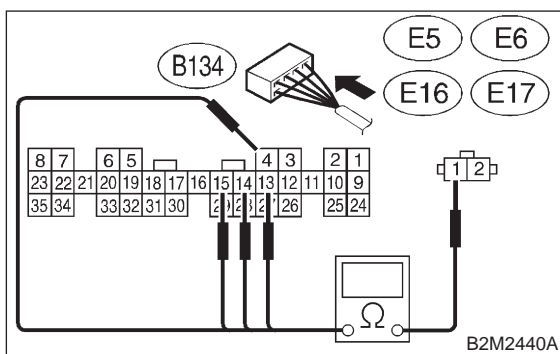

- CHECK** : Is the resistance less than 1 Ω?
- YES** : Go to step 11AA5.
- NO** : Repair harness and connector.

NOTE:

In this case, repair the following:

- Open circuit in harness between ECM and fuel injector connector
- Poor contact in coupling connector (B22)

11AA5 : CHECK FUEL INJECTOR.

Measure resistance between fuel injector terminals on faulty cylinder.

Terminals

No. 1 — No. 2:

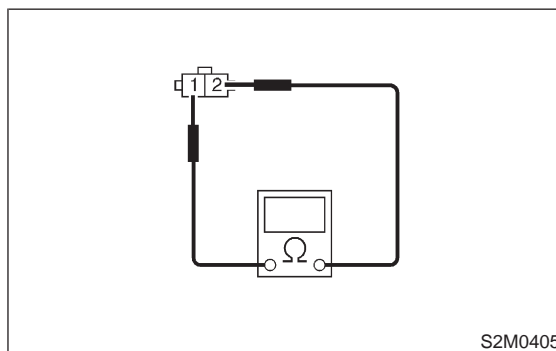

- CHECK** : Is the resistance between 5 and 20 Ω?
- YES** : Go to step 11AA6.
- NO** : Replace faulty fuel injector. <Ref. to 2-7 [W14A0].>

11AA6 : CHECK POWER SUPPLY LINE.

- 1) Turn ignition switch to ON.
- 2) Measure voltage between fuel injector and engine ground on faulty cylinders.

Connector & terminal

- #1; (E5) No. 2 (+) — Engine ground (-):
- #2; (E16) No. 2 (+) — Engine ground (-):
- #3; (E6) No. 2 (+) — Engine ground (-):
- #4; (E17) No. 2 (+) — Engine ground (-):

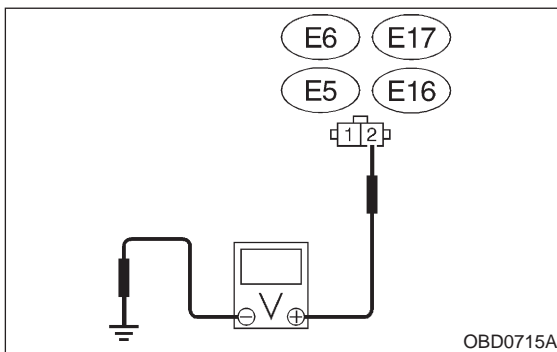

- CHECK** : Is the voltage more than 10 V?
- YES** : Repair poor contact in all connectors in fuel injector circuit.
- NO** : Repair harness and connector.

NOTE:

In this case, repair the following:

- Open circuit in harness between main relay and fuel injector connector on faulty cylinders
- Poor contact in coupling connector (B22)
- Poor contact in main relay connector
- Poor contact in fuel injector connector on faulty cylinders

11AA7 : CHECK HARNESS BETWEEN FUEL INJECTOR AND ECM CONNECTOR.

- 1) Turn ignition switch to OFF.
- 2) Disconnect connector from fuel injector on faulty cylinder.
- 3) Turn ignition switch to ON.
- 4) Measure voltage between ECM connector and chassis ground on faulty cylinders.

Connector & terminal

- #1; (B134) No. 4 (+) — Chassis ground (-):
- #2; (B134) No. 13 (+) — Chassis ground (-):
- #3; (B134) No. 14 (+) — Chassis ground (-):
- #4; (B134) No. 15 (+) — Chassis ground (-):

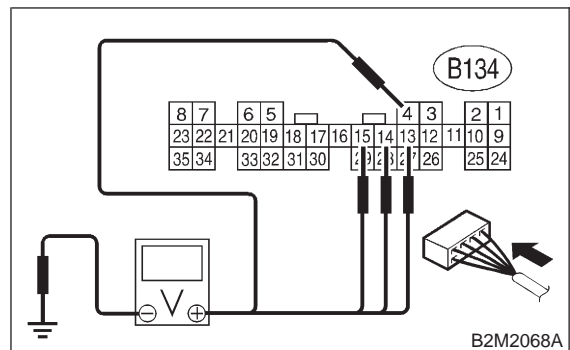

- CHECK** : Is the voltage more than 10 V?
- YES** : Repair battery short circuit in harness between ECM and fuel injector. After repair, replace ECM. <Ref. to 2-7 [W15A0].>
- NO** : Go to step 11AA8.

11AA8 : CHECK FUEL INJECTOR.

- 1) Turn ignition switch to OFF.
- 2) Measure resistance between fuel injector terminals on faulty cylinder.

Terminals

No. 1 — No. 2 :

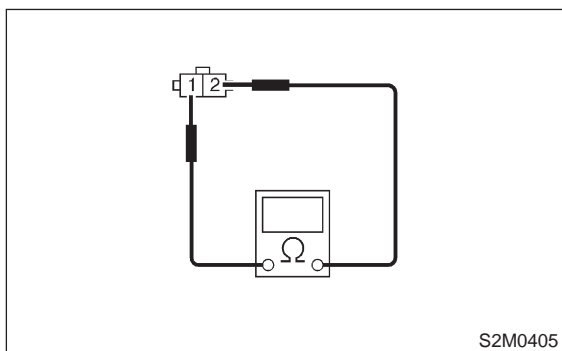

- CHECK** : *Is the resistance less than 1 Ω?*
- YES** : Replace faulty fuel injector <Ref. to 2-7 [W14A0].> and ECM <Ref. to 2-7 [W15A0].>.
- NO** : Go to step 11AA9.

11AA9 : CHECK FUEL LEVEL.

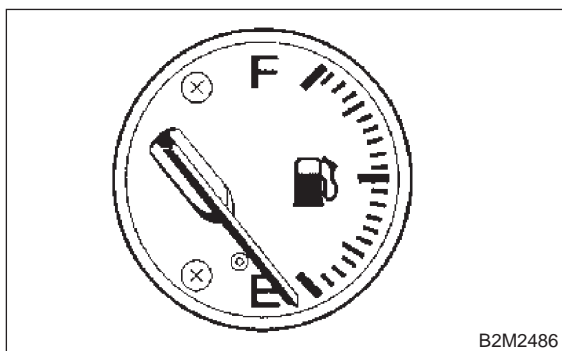

- CHECK** : *Is fuel meter indication (in combination meter) higher than the "Lower" level?*
- YES** : Go to step 11AA10.
- NO** : Replenish fuel so fuel meter indication is higher than the "Lower" level. After refuel, Go to step 11AA10. <Ref. to 2-7 [T11AA10].>

11AA10 : CHECK STATUS OF CHECK ENGINE MALFUNCTION INDICATOR LAMP (MIL).

- 1) Turn ignition switch to OFF.
- 2) Connect Subaru Select Monitor to the data link connector.

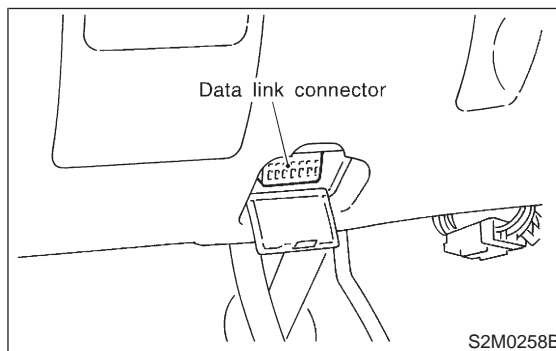

- 3) Clear memory using Subaru Select Monitor. <Ref. to 2-7 [T3D0].>
- 4) Start engine, and drive the vehicle more than 10 minutes.

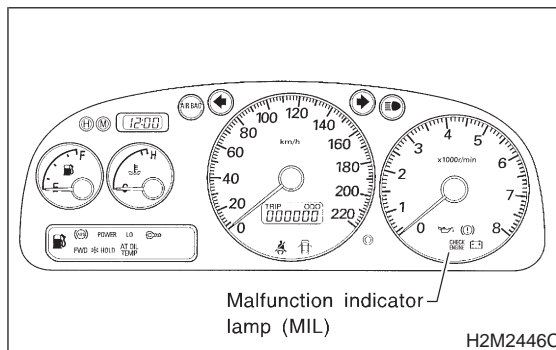

- CHECK** : *Is the MIL coming on or blinking?*
- YES** : Go to step 11AA12.
- NO** : Go to step 11AA11.

11AA11 : CHECK CAUSE OF MISFIRE DIAGNOSED.

CHECK : ***Was the cause of misfire diagnosed when the engine is running?***

YES : Finish diagnostics operation, if the engine has no abnormality.

NOTE:

Ex. Remove spark plug cord, etc.

NO : Repair poor contact.

NOTE:

In this case, repair the following:

- Poor contact in ignitor connector
- Poor contact in ignition coil connector
- Poor contact in fuel injector connector on faulty cylinders
- Poor contact in ECM connector
- Poor contact in coupling connector (B22)

11AA12 : CHECK AIR INTAKE SYSTEM.

CHECK : ***Is there a fault in air intake system?***

YES : Repair air intake system.

NOTE:

Check the following items:

- Are there air leaks or air suction caused by loose or dislocated nuts and bolts?
- Are there cracks or any disconnection of hoses?

NO : Go to step 11AA13.

11AA13 : CHECK MISFIRE SYMPTOM.

- 1) Turn ignition switch to OFF.
- 2) Connect the Subaru Select Monitor or the OBD-II general scan tool to data link connector.

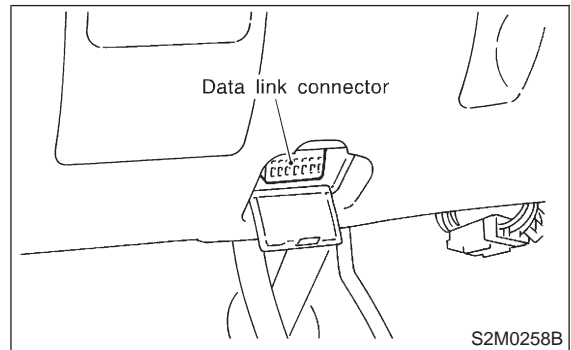

- 3) Turn ignition switch to ON, and turn Subaru Select Monitor or OBD-II general scan tool switch to ON.

- 4) Read diagnostic trouble code (DTC).

- Subaru Select Monitor

<Ref. to 2-7 [T3C2].>

- OBD-II general scan tool

For detailed operation procedures, refer to the OBD-II General Scan Tool Operation Manual.

NOTE:

Perform diagnosis according to the items listed below.

CHECK : ***Does the Subaru Select Monitor or OBD-II general scan tool indicate only one DTC?***

YES : Go to step 11AA18.

NO : Go to step 11AA14.

11AA14 : CHECK DIAGNOSTIC TROUBLE CODE (DTC) ON DISPLAY.

CHECK : ***Does the Subaru Select Monitor or OBD-II general scan tool indicate DTC P0301 and P0302?***

YES : Go to step 11AA19.

NO : Go to step 11AA15.

11AA15 : CHECK DIAGNOSTIC TROUBLE CODE (DTC) ON DISPLAY.

CHECK : ***Does the Subaru Select Monitor or OBD-II general scan tool indicate DTC P0303 and P0304?***

YES : Go to step 11AA20.

NO : Go to step 11AA16.

11AA16 : CHECK DIAGNOSTIC TROUBLE CODE (DTC) ON DISPLAY.

CHECK : *Does the Subaru Select Monitor or OBD-II general scan tool indicate DTC P0301 and P0303?*

YES : Go to step 11AA21.

NO : Go to step 11AA17.

11AA17 : CHECK DIAGNOSTIC TROUBLE CODE (DTC) ON DISPLAY.

CHECK : *Does the Subaru Select Monitor or OBD-II general scan tool indicate DTC P0302 and P0304?*

YES : Go to step 11AA22.

NO : Go to step 11AA18.

11AA18 : ONLY ONE CYLINDER

CHECK : *Is there a fault in that cylinder?*

YES : Repair or replace faulty parts.

NOTE:

Check the following items.

- Spark plug
- Spark plug cord
- Fuel injector
- Compression ratio

NO : Go to DTC P0170. <Ref. to 2-7 [T11T0].>

11AA19 : GROUP OF #1 AND #2 CYLINDERS

CHECK : *Are there faults in #1 and #2 cylinders?*

YES : Repair or replace faulty parts.

NOTE:

Check the following items.

- Spark plugs
- Fuel injectors
- Ignition coil
- Compression ratio
- If no abnormal is discovered, check for "8. D: IGNITION CONTROL SYSTEM" of #1 and #2 cylinders side. <Ref. to 2-7 [T8D0].>

NO : Go to DTC P0170. <Ref. to 2-7 [T11T0].>

11AA20 : GROUP OF #3 AND #4 CYLINDERS

CHECK : *Are there faults in #3 and #4 cylinders?*

YES : Repair or replace faulty parts.

NOTE:

Check the following items.

- Spark plugs
- Fuel injectors
- Ignition coil
- If no abnormal is discovered, check for "8. D: IGNITION CONTROL SYSTEM" of #3 and #4 cylinders side. <Ref. to 2-7 [T8D0].>

NO : Go to DTC P0170. <Ref. to 2-7 [T11T0].>

11AA21 : GROUP OF #1 AND #3 CYLINDERS

CHECK : *Are there faults in #1 and #3 cylinders?*

YES : Repair or replace faulty parts.

NOTE:

Check the following items.

- Spark plugs
- Fuel injectors
- Skipping timing belt teeth

NO : Go to DTC P0170. <Ref. to 2-7 [T11T0].>

11AA22 : GROUP OF #2 AND #4 CYLINDERS

CHECK : *Are there faults in #2 and #4 cylinders?*

YES : Repair or replace faulty parts.

NOTE:

Check the following items.

- Spark plugs
- Fuel injectors
- Compression ratio
- Skipping timing belt teeth

NO : Go to DTC P0170. <Ref. to 2-7 [T11T0].>

2-7 [T11AA23]

ON-BOARD DIAGNOSTICS II SYSTEM

11. Diagnostics Chart with Trouble Code for Except 2200 cc California Spec. Vehicles

11AA23 : CYLINDER AT RANDOM

CHECK : *Is the engine idle rough?*

YES : Go to DTC P0170. <Ref. to 2-7 [T11T0].>

NO : Repair or replace faulty parts.

NOTE:

Check the following items.

- Spark plugs
- Fuel injectors
- Compression ratio

AB: DTC P0325 — KNOCK SENSOR CIRCUIT MALFUNCTION —

- **DTC DETECTING CONDITION:**
 - Immediately at fault recognition
- **TROUBLE SYMPTOM:**
 - Poor driving performance
 - Knocking occurs.

CAUTION:

After repair or replacement of faulty parts, conduct CLEAR MEMORY MODE <Ref. to 2-7 [T3D0].> and INSPECTION MODE <Ref. to 2-7 [T3E0].>

● **WIRING DIAGRAM:**

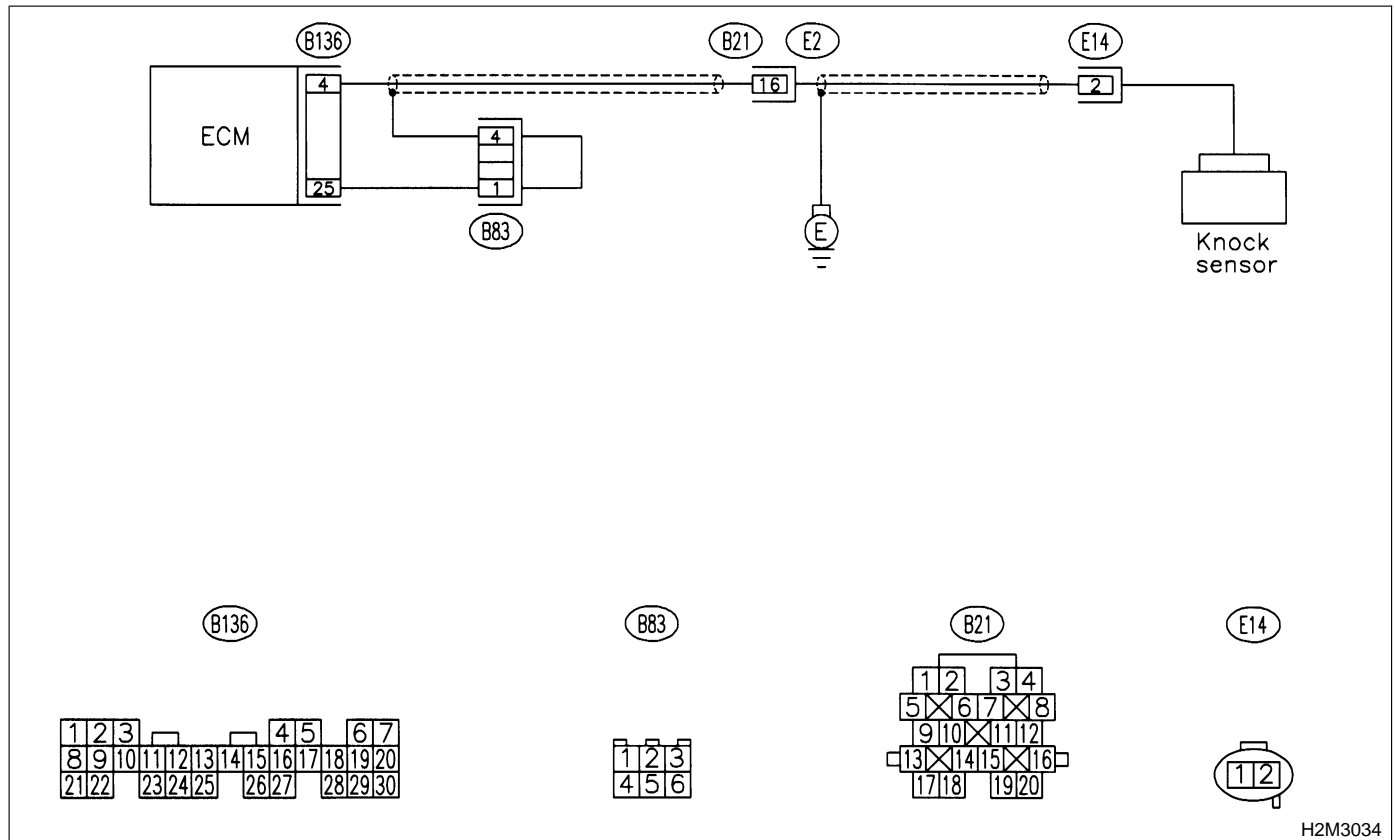

H2M3034

2-7 [T11AB1]

ON-BOARD DIAGNOSTICS II SYSTEM

11. Diagnostics Chart with Trouble Code for Except 2200 cc California Spec. Vehicles

11AB1 : CHECK HARNESS BETWEEN KNOCK SENSOR AND ECM CONNECTOR.

- 1) Turn ignition switch to OFF.
- 2) Disconnect connector from ECM.
- 3) Measure resistance between ECM harness connector and chassis ground.

Connector & terminal

(B136) No. 4 — Chassis ground:

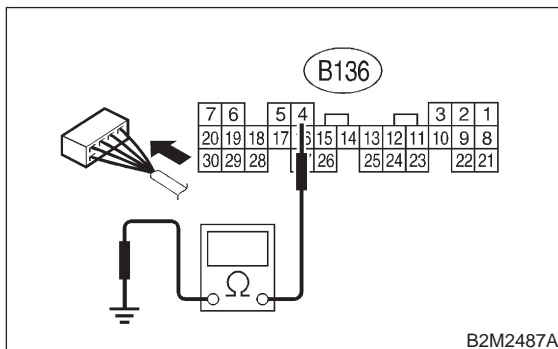

- CHECK** : Is the resistance more than 700 k Ω ?
- YES** : Go to step 11AB3.
- NO** : Go to step 11AB2.

11AB2 : CHECK HARNESS BETWEEN KNOCK SENSOR AND ECM CONNECTOR.

Measure resistance of harness between ECM connector and chassis ground.

Connector & terminal

(B136) No. 4 — Chassis ground:

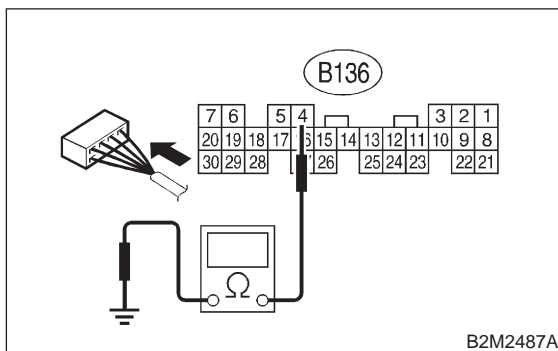

- CHECK** : Is the resistance less than 400 k Ω ?
- YES** : Go to step 11AB5.
- NO** : Go to step 11AB6.

11AB3 : CHECK KNOCK SENSOR.

- 1) Disconnect connector from knock sensor.
- 2) Measure resistance between knock sensor connector terminal and engine ground.

Terminal

No. 2 — Engine ground:

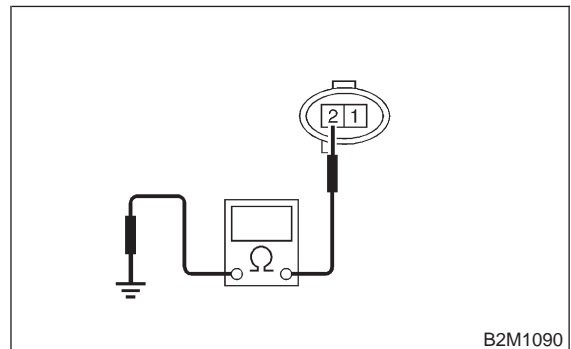

- CHECK** : Is the resistance more than 700 k Ω ?
- YES** : Go to step 11AB4.
- NO** : Repair harness and connector.

NOTE:

In this case, repair the following:

- Open circuit in harness between knock sensor and ECM connector
- Poor contact in knock sensor connector
- Poor contact in coupling connector (B21)

11AB4 : CHECK CONDITION OF KNOCK SENSOR INSTALLATION.

- CHECK** : Is the knock sensor installation bolt tightened securely?
- YES** : Replace knock sensor. <Ref. to 2-7 [W19A0].>
- NO** : Tighten knock sensor installation bolt securely.

11AB5 : CHECK KNOCK SENSOR.

- 1) Disconnect connector from knock sensor.
- 2) Measure resistance between knock sensor connector terminal and engine ground.

Terminal

No. 2 — Engine ground:

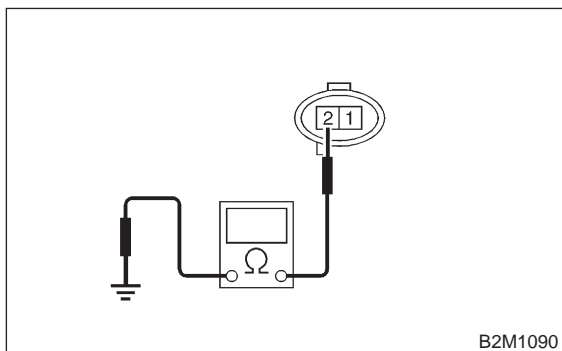

- CHECK** : *Is the resistance less than 400 kΩ?*
- YES** : Replace knock sensor. <Ref. to 2-7 [W19A0].>
- NO** : Repair ground short circuit in harness between knock sensor connector and ECM connector.

NOTE:

The harness between both connectors is shielded. Repair short circuit of harness together with shield.

11AB6 : CHECK INPUT SIGNAL FOR ECM.

- 1) Connect connectors to ECM and knock sensor.
- 2) Turn ignition switch to ON.
- 3) Measure voltage between ECM and chassis ground.

Connector & terminal

(B136) No. 4 (+) — Chassis ground (-):

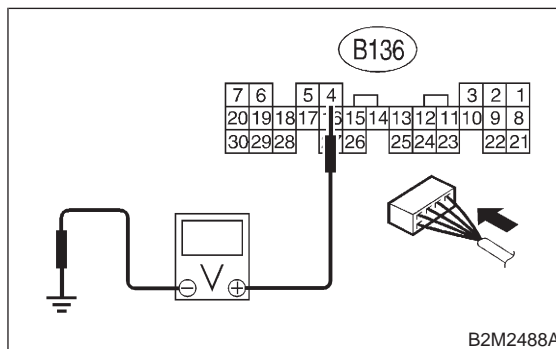

- CHECK** : *Is the voltage more than 2 V?*
- YES** : Even if MIL lights up, the circuit has returned to a normal condition at this time. (However, the possibility of poor contact still remains.)

NOTE:

In this case, repair the following:

- Poor contact in knock sensor connector
- Poor contact in ECM connector
- Poor contact in coupling connector (B21)

- NO** : Repair poor contact in ECM connector.

2-7 [T11AB6]

ON-BOARD DIAGNOSTICS II SYSTEM

11. Diagnostics Chart with Trouble Code for Except 2200 cc California Spec. Vehicles

MEMO:

AC: DTC P0335 — CRANKSHAFT POSITION SENSOR CIRCUIT MALFUNCTION —

- **DTC DETECTING CONDITION:**
 - Immediately at fault recognition
- **TROUBLE SYMPTOM:**
 - Engine stalls.
 - Failure of engine to start

CAUTION:

After repair or replacement of faulty parts, conduct **CLEAR MEMORY MODE** <Ref. to 2-7 [T3D0].> and **INSPECTION MODE** <Ref. to 2-7 [T3E0].>.

● **WIRING DIAGRAM:**

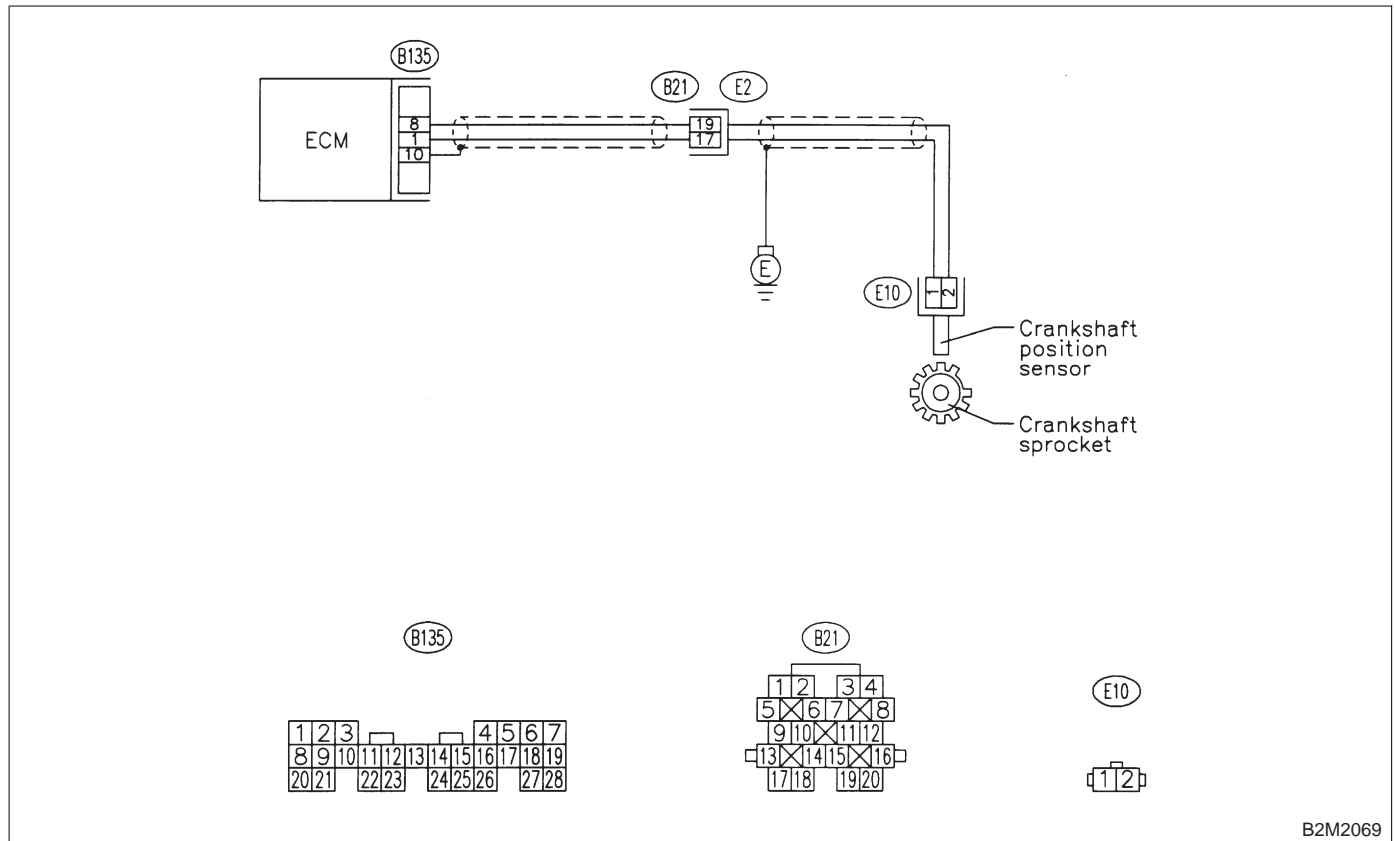

B2M2069

2-7 [T11AC1]

ON-BOARD DIAGNOSTICS II SYSTEM

11. Diagnostics Chart with Trouble Code for Except 2200 cc California Spec. Vehicles

11AC1 : CHECK HARNESS BETWEEN CRANKSHAFT POSITION SENSOR AND ECM CONNECTOR.

- 1) Turn ignition switch to OFF.
- 2) Disconnect connector from crankshaft position sensor.
- 3) Measure resistance of harness between crankshaft position sensor connector and engine ground.

Connector & terminal

(E10) No. 1 — Engine ground:

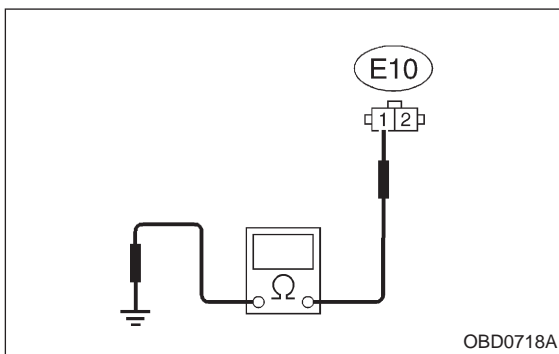

CHECK : Is the resistance more than 100 kΩ?

YES : Repair harness and connector.

NOTE:

In this case, repair the following:

- Open circuit in harness between crankshaft position sensor and ECM connector
- Poor contact in ECM connector
- Poor contact in coupling connector (B21)

NO : Go to step **11AC2**.

11AC2 : CHECK HARNESS BETWEEN CRANKSHAFT POSITION SENSOR AND ECM CONNECTOR.

Measure resistance of harness between crankshaft position sensor connector and engine ground.

Connector & terminal

(E10) No. 1 — Engine ground:

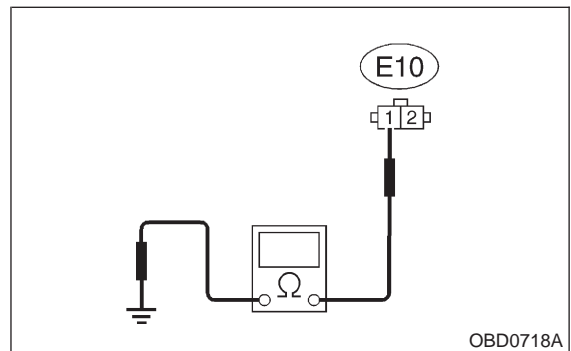

CHECK : Is the resistance less than 10 Ω?

YES : Repair ground short circuit in harness between crankshaft position sensor and ECM connector.

NOTE:

The harness between both connectors are shielded. Repair ground short circuit in harness together with shield.

NO : Go to step **11AC3**.

11AC3 : CHECK HARNESS BETWEEN CRANKSHAFT POSITION SENSOR AND ECM CONNECTOR.

Measure resistance of harness between crankshaft position sensor connector and engine ground.

Connector & terminal (E10) No. 2 — Engine ground:

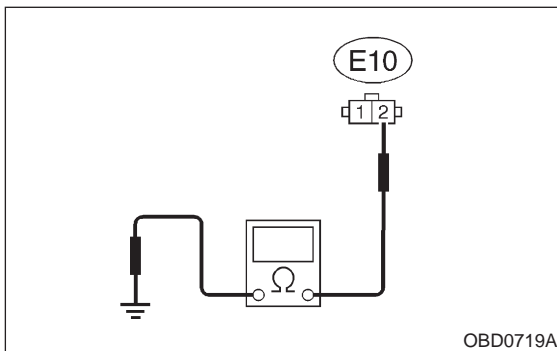

CHECK : *Is the resistance less than 5 Ω?*

YES : Go to step 11AC4.

NO : Repair harness and connector.

NOTE:

In this case, repair the following:

- Open circuit in harness between crankshaft position sensor and ECM connector
- Poor contact in ECM connector
- Poor contact in coupling connector (B21)

11AC4 : CHECK CONDITION OF CRANKSHAFT POSITION SENSOR.

CHECK : *Is the crankshaft position sensor installation bolt tightened securely?*

YES : Go to step 11AC5.

NO : Tighten crankshaft position sensor installation bolt securely.

11AC5 : CHECK CRANKSHAFT POSITION SENSOR.

- 1) Remove crankshaft position sensor.
- 2) Measure resistance between connector terminals of crankshaft position sensor.

Terminals

No. 1 — No. 2:

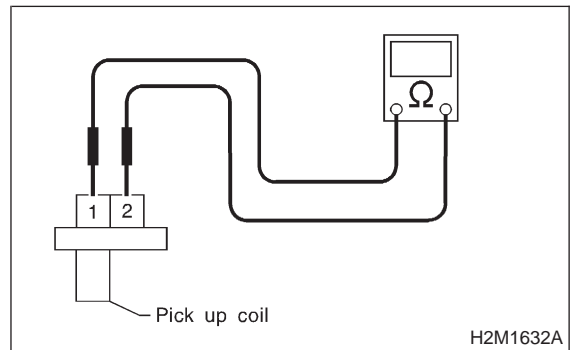

CHECK : *Is the resistance between 1 and 4 kΩ?*

YES : Repair poor contact in crankshaft position sensor connector.

NO : Replace crankshaft position sensor. <Ref. to 2-7 [W6A0].>

2-7 [T11AC5]

ON-BOARD DIAGNOSTICS II SYSTEM

11. Diagnostics Chart with Trouble Code for Except 2200 cc California Spec. Vehicles

MEMO:

AD: DTC P0336 — CRANKSHAFT POSITION SENSOR CIRCUIT RANGE/PERFORMANCE PROBLEM —

- **DTC DETECTING CONDITION:**
 - Immediately at fault recognition
- **TROUBLE SYMPTOM:**
 - Engine stalls.
 - Failure of engine to start

CAUTION:

After repair or replacement of faulty parts, conduct **CLEAR MEMORY MODE** <Ref. to 2-7 [T3D0].> and **INSPECTION MODE** <Ref. to 2-7 [T3E0].>

● **WIRING DIAGRAM:**

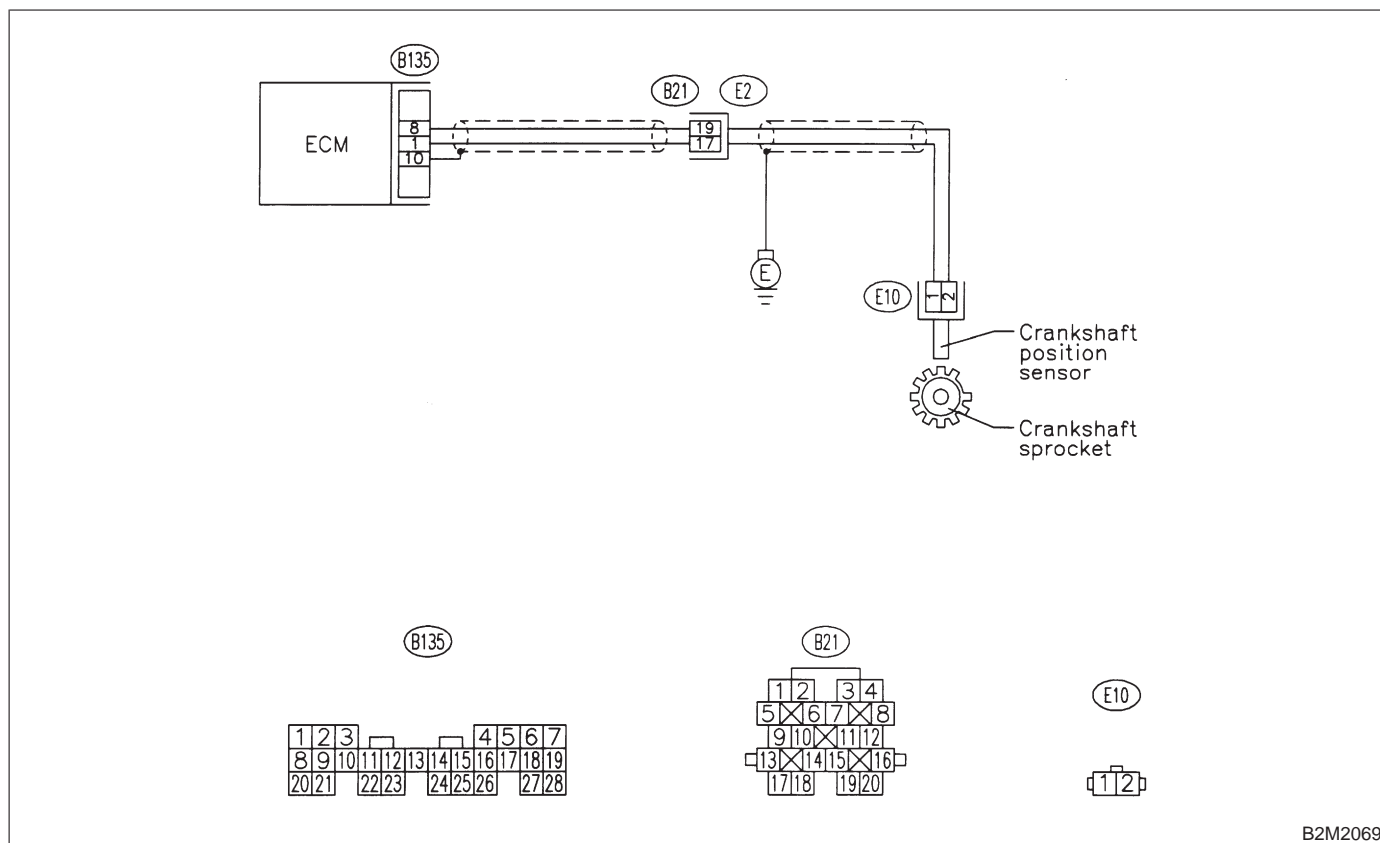

B2M2069

11AD1 : CHECK ANY OTHER DTC ON DISPLAY.

11AD2 : CHECK CONDITION OF CRANKSHAFT POSITION SENSOR.

- CHECK** : Does the Subaru Select Monitor or OBD-II general scan tool indicate DTC P0335?
- YES** : Inspect DTC P0335 using "11. Diagnostics Chart with Trouble Code for Except 2200 cc California Spec. Vehicles". <Ref. to 2-7 [T11A0].>
- NO** : Go to step 11AD2.

- Turn ignition switch to OFF.
- CHECK** : Is the crankshaft position sensor installation bolt tightened securely?
 - YES** : Go to step 11AD3.
 - NO** : Tighten crankshaft position sensor installation bolt securely.

2-7 [T11AD3]

ON-BOARD DIAGNOSTICS II SYSTEM

11. Diagnostics Chart with Trouble Code for Except 2200 cc California Spec. Vehicles

11AD3 : CHECK CRANKSHAFT SPROCKET.

Remove front belt cover. <Ref. to 2-3 [W2A1].>

- CHECK** : **Are there any cracks or damages in the crankshaft sprocket teeth?**
- YES** : Replace crankshaft sprocket. <Ref. to 2-3 [W2A4].>
- NO** : Go to step 11AD4.

11AD4 : CHECK INSTALLATION CONDITION OF TIMING BELT.

Turn crankshaft using ST, and align alignment mark on crankshaft sprocket. Then, make sure left and right camshaft sprockets are matched with notches (alignment marks of belt cover and cylinder head).

ST 499987500 CRANKSHAFT SOCKET

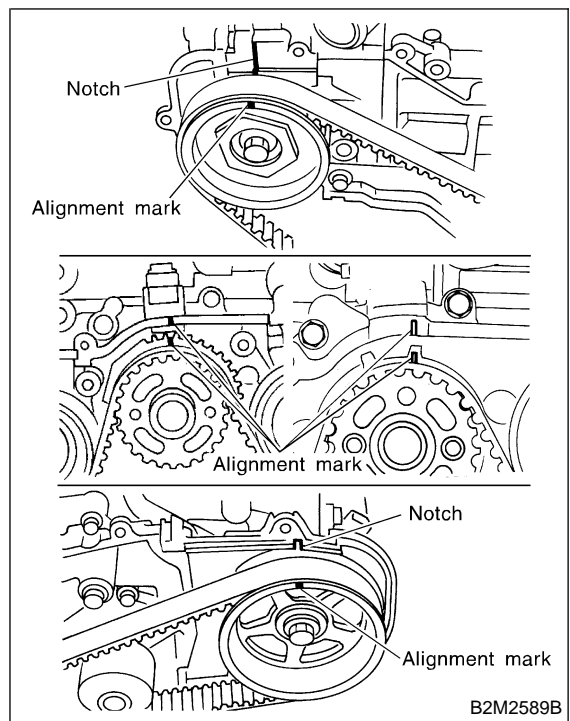
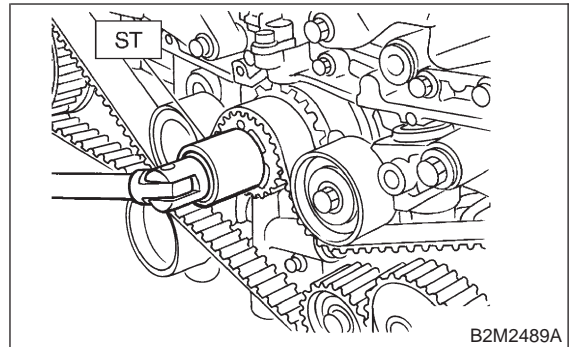

- CHECK** : **Is timing belt installed properly in accordance with the correct position of crankshaft and camshaft sprockets?**
- YES** : Repair installation condition of timing belt. <Ref. to 2-3 [W2A0].>
- NO** : Replace crankshaft position sensor. <Ref. to 2-7 [W6A0].>

AE: DTC P0340 — CAMSHAFT POSITION SENSOR CIRCUIT MALFUNCTION

- **DTC DETECTING CONDITION:**
 - Immediately at fault recognition
- **TROUBLE SYMPTOM:**
 - Engine stalls.
 - Failure of engine to start

CAUTION:

After repair or replacement of faulty parts, conduct CLEAR MEMORY MODE <Ref. to 2-7 [T3D0].> and INSPECTION MODE <Ref. to 2-7 [T3E0].>

● **WIRING DIAGRAM:**

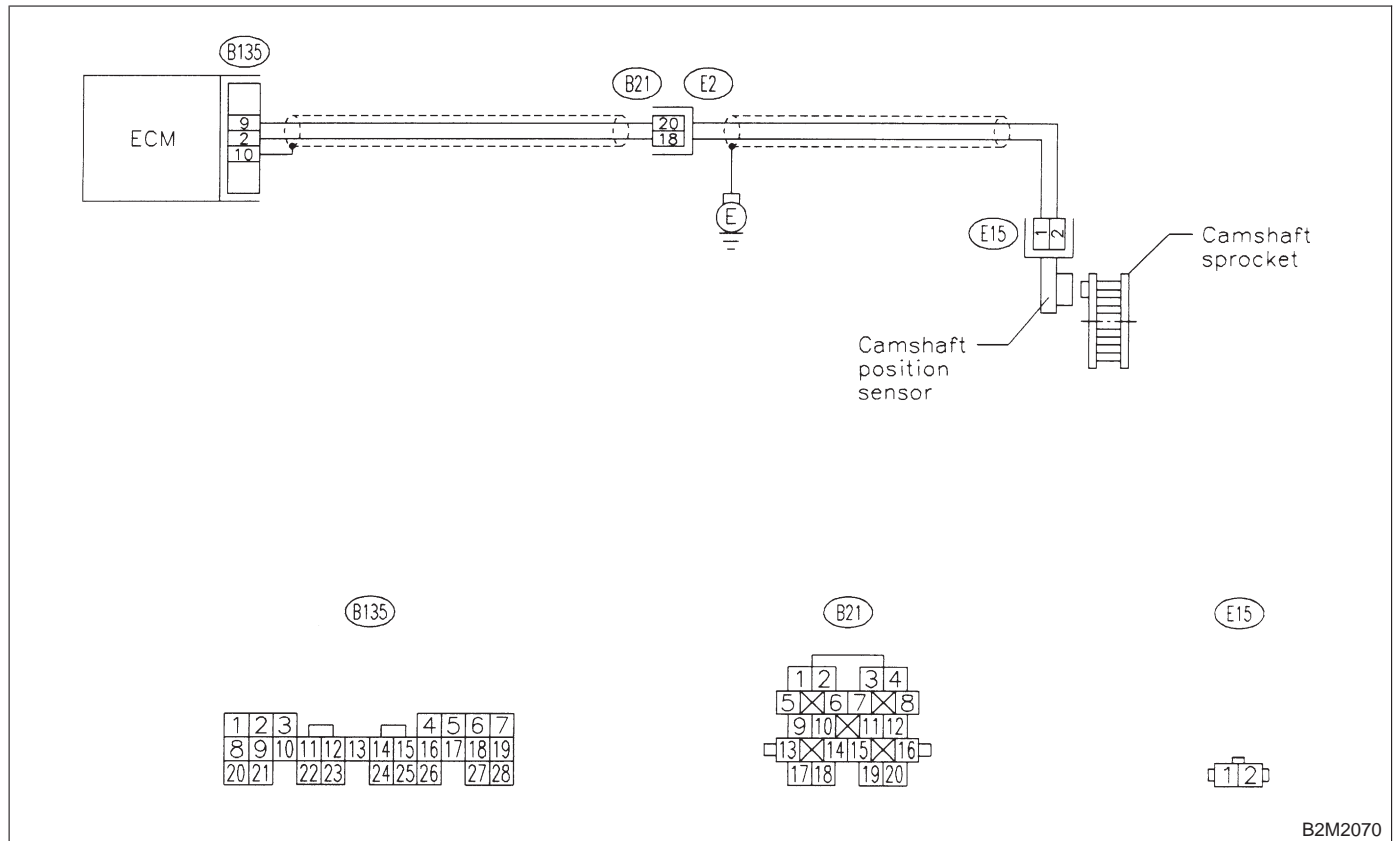

2-7 [T11AE1]

ON-BOARD DIAGNOSTICS II SYSTEM

11. Diagnostics Chart with Trouble Code for Except 2200 cc California Spec. Vehicles

11AE1 : CHECK HARNESS BETWEEN CAMSHAFT POSITION SENSOR AND ECM CONNECTOR.

- 1) Turn ignition switch to OFF.
- 2) Disconnect connector from camshaft position sensor.
- 3) Measure resistance of harness between camshaft position sensor connector and engine ground.

Connector & terminal

(E15) No. 1 — Engine ground:

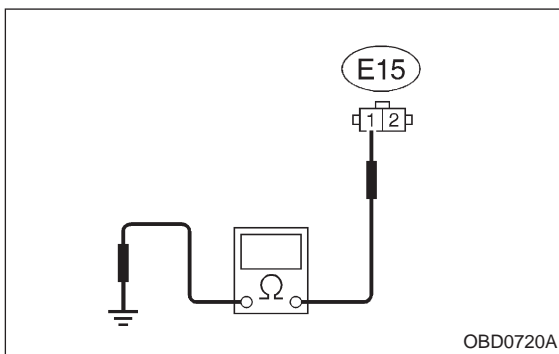

CHECK : Is the resistance more than 100 k Ω ?

YES : Repair harness and connector.

NOTE:

In this case, repair the following:

- Open circuit in harness between camshaft position sensor and ECM connector
- Poor contact in ECM connector
- Poor contact in coupling connector (B21)

NO : Go to step 11AE2.

11AE2 : CHECK HARNESS BETWEEN CAMSHAFT POSITION SENSOR AND ECM CONNECTOR.

Measure resistance of harness between camshaft position sensor connector and engine ground.

Connector & terminal

(E15) No. 1 — Engine ground:

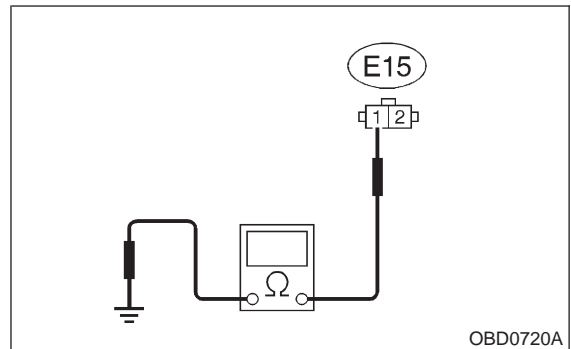

CHECK : Is the resistance less than 10 Ω ?

YES : Repair ground short circuit in harness between camshaft position sensor and ECM connector.

NOTE:

The harness between both connectors are shielded. Repair ground short circuit in harness together with shield.

NO : Go to step 11AE3.

11AE3 : CHECK HARNESS BETWEEN CAMSHAFT POSITION SENSOR AND ECM CONNECTOR.

Measure resistance of harness between camshaft position sensor connector and engine ground.

Connector & terminal
(E15) No. 2 — Engine ground:

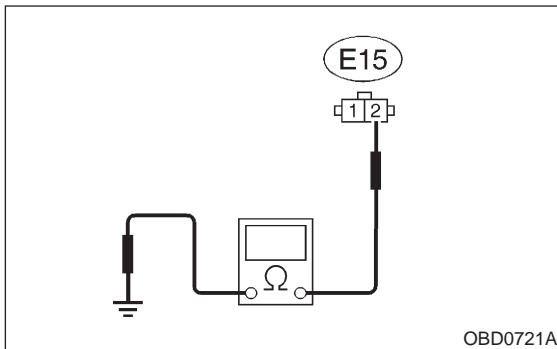

- CHECK** : *Is the resistance less than 5 Ω?*
- YES** : Go to step 11AE4.
- NO** : Repair harness and connector.

NOTE:

In this case, repair the following:

- Open circuit in harness between camshaft position sensor and ECM connector
- Poor contact in ECM connector
- Poor contact in coupling connector (B21)

11AE4 : CHECK CONDITION OF CAMSHAFT POSITION SENSOR.

- CHECK** : *Is the camshaft position sensor installation bolt tightened securely?*
- YES** : Go to step 11AE5.
- NO** : Tighten camshaft position sensor installation bolt securely.

11AE5 : CHECK CAMSHAFT POSITION SENSOR.

- 1) Remove camshaft position sensor.
- 2) Measure resistance between connector terminals of camshaft position sensor.

Terminals

No. 1 — No. 2:

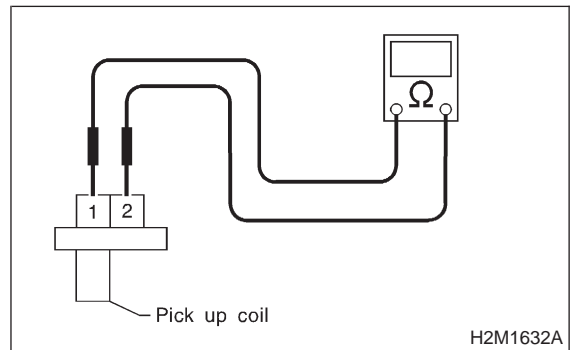

- CHECK** : *Is the resistance between 1 and 4 kΩ?*
- YES** : Repair poor contact in camshaft position sensor connector.
- NO** : Replace camshaft position sensor. <Ref. to 2-7 [W10A0].>

2-7 [T11AE5]

ON-BOARD DIAGNOSTICS II SYSTEM

11. Diagnostics Chart with Trouble Code for Except 2200 cc California Spec. Vehicles

MEMO:

AF: DTC P0341 — CAMSHAFT POSITION SENSOR CIRCUIT RANGE/PERFORMANCE PROBLEM —

- **DTC DETECTING CONDITION:**
 - Immediately at fault recognition
- **TROUBLE SYMPTOM:**
 - Engine stalls.
 - Failure of engine to start

CAUTION:

After repair or replacement of faulty parts, conduct **CLEAR MEMORY MODE** <Ref. to 2-7 [T3D0].> and **INSPECTION MODE** <Ref. to 2-7 [T3E0].>

● **WIRING DIAGRAM:**

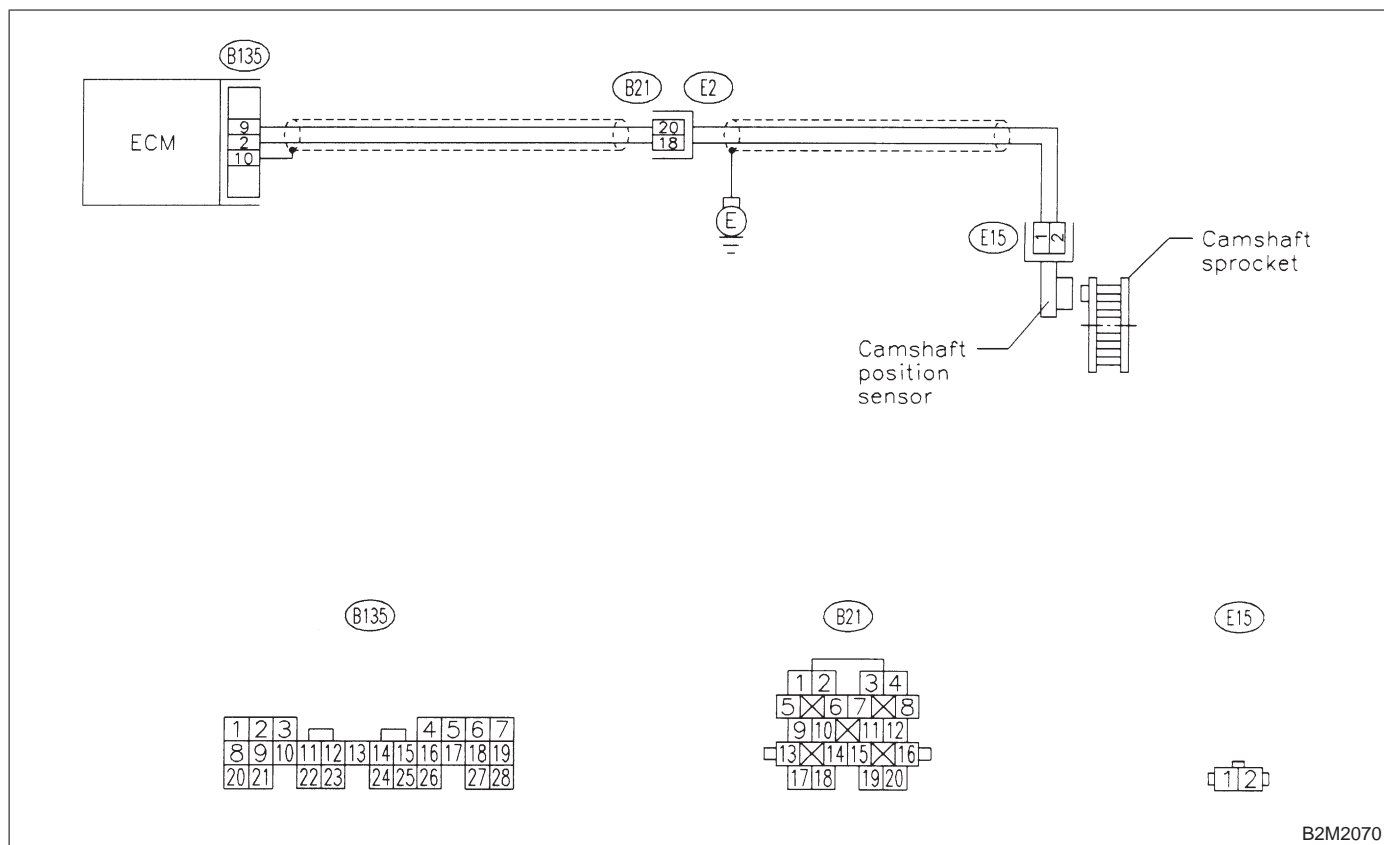

B2M2070

11AF1 : CHECK ANY OTHER DTC ON DISPLAY.

- CHECK** : Does the Subaru Select Monitor or OBD-II general scan tool indicate DTC P0340?
- YES** : Inspect DTC P0340 using “11. Diagnostics Chart with Trouble Code for Except 2200 cc California Spec. Vehicles”. <Ref. to 2-7 [T11A0].>
- NO** : Go to step 11AF2.

2-7 [T11AF2]

ON-BOARD DIAGNOSTICS II SYSTEM

11. Diagnostics Chart with Trouble Code for Except 2200 cc California Spec. Vehicles

11AF2 : CHECK HARNESS BETWEEN CAMSHAFT POSITION SENSOR AND ECM CONNECTOR.

- 1) Turn ignition switch to OFF.
- 2) Disconnect connector from camshaft position sensor.
- 3) Measure resistance of harness between camshaft position sensor connector and engine ground.

Connector & terminal

(E15) No. 1 — Engine ground:

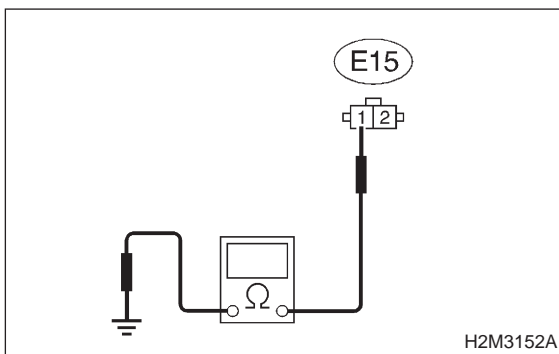

CHECK : Is the resistance more than 100 kΩ?

YES : Repair harness and connector.

NOTE:

In this case, repair the following:

- Open circuit in harness between camshaft position sensor and ECM connector
- Poor contact in ECM connector
- Poor contact in coupling connector (B21)

NO : Go to step 11AF3.

11AF3 : CHECK HARNESS BETWEEN CAMSHAFT POSITION SENSOR AND ECM CONNECTOR.

Measure resistance of harness between camshaft position sensor connector and engine ground.

Connector & terminal

(E15) No. 1 — Engine ground:

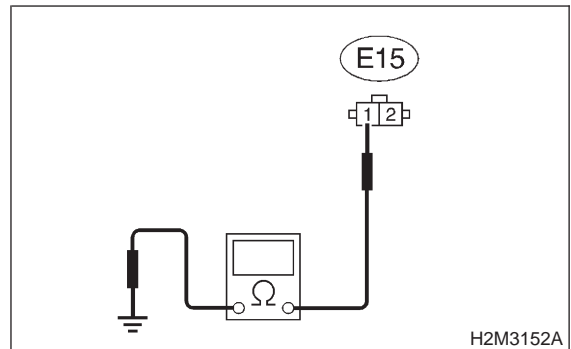

CHECK : Is the resistance less than 10 Ω?

YES : Repair ground short circuit in harness between camshaft position sensor and ECM connector.

NOTE:

The harness between both connectors are shielded. Repair ground short circuit in harness together with shield.

NO : Go to step 11AF4.

11AF4 : CHECK HARNESS BETWEEN CAMSHAFT POSITION SENSOR AND ECM CONNECTOR.

Measure resistance of harness between camshaft position sensor connector and engine ground.

Connector & terminal

(E15) No. 2 — Engine ground:

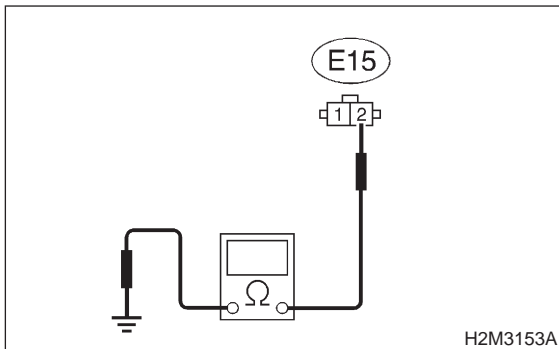

- CHECK** : *Is the resistance less than 5 Ω?*
- YES** : Go to step 11AF5.
- NO** : Repair harness and connector.

NOTE:

In this case, repair the following:

- Open circuit in harness between camshaft position sensor and ECM connector
- Poor contact in ECM connector
- Poor contact in coupling connector (B21)

11AF5 : CHECK CAMSHAFT POSITION SENSOR.

- 1) Remove camshaft position sensor.
- 2) Measure resistance between connector terminals of camshaft position sensor.

Terminals

No. 1 — No. 2:

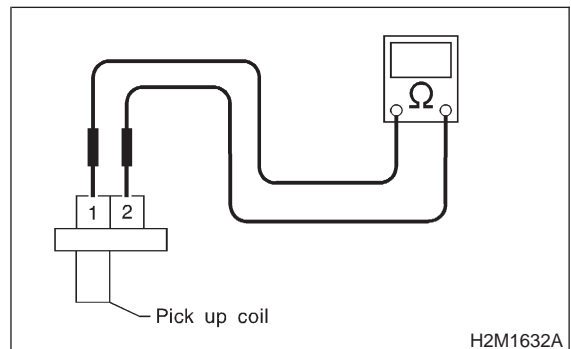

- CHECK** : *Is the resistance between 1 and 4 kΩ?*
- YES** : Go to step 11AF6.
- NO** : Replace camshaft position sensor. <Ref. to 2-7 [W10A0].>

11AF6 : CHECK CONDITION OF CAMSHAFT POSITION SENSOR.

Turn ignition switch to OFF.

- CHECK** : *Is the camshaft position sensor installation bolt tightened securely?*
- YES** : Go to step 11AF7.
- NO** : Tighten camshaft position sensor installation bolt securely.

11AF7 : CHECK CAMSHAFT SPROCKET.

Remove front belt cover. <Ref. to 2-3 [W2A1].>

- CHECK** : *Are there any cracks or damages in the camshaft sprocket teeth?*
- YES** : Replace camshaft sprocket. <Ref. to 2-3 [W2A4].>
- NO** : Go to step 11AF8.

2-7 [T11AF8]

ON-BOARD DIAGNOSTICS II SYSTEM

11. Diagnostics Chart with Trouble Code for Except 2200 cc California Spec. Vehicles

11AF8 : CHECK INSTALLATION CONDI- TION OF TIMING BELT.

Turn crankshaft using ST, and align alignment mark on crankshaft sprocket. Then, make sure left and right camshaft sprockets are matched with notches (alignment marks of belt cover and cylinder head).

ST 499987500 CRANKSHAFT SOCKET

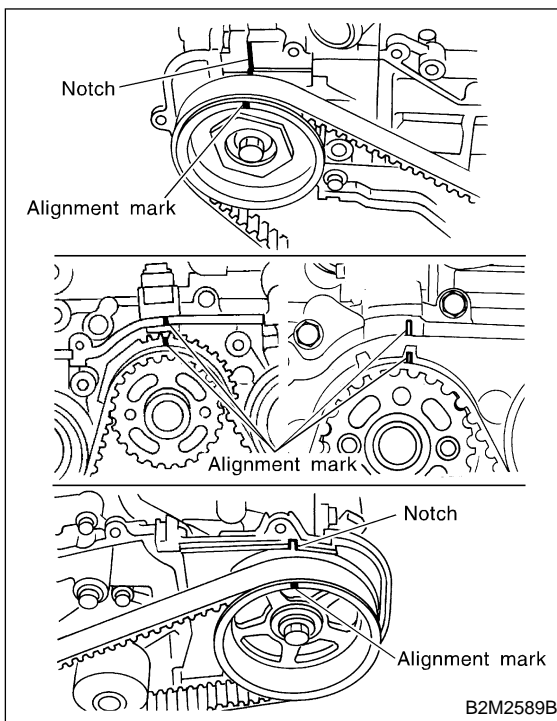
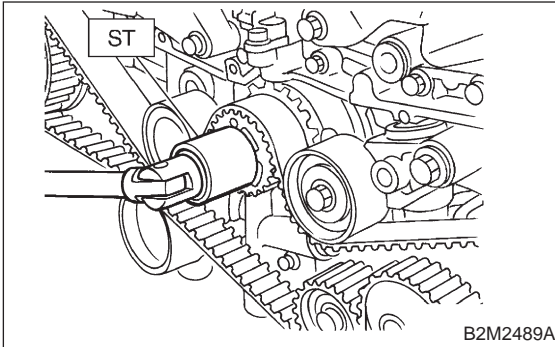

- CHECK** : *Is timing belt installed properly in accordance with the correct position of crankshaft and camshaft sprockets?*
- YES** : Repair installation condition of timing belt. <Ref. to 2-3 [W2A0].>
- NO** : Replace camshaft position sensor. <Ref. to 2-7 [W10A0].>

AG: DTC P0420 — CATALYST SYSTEM EFFICIENCY BELOW THRESHOLD

- **DTC DETECTING CONDITION:**
 - Two consecutive driving cycles with fault
- **TROUBLE SYMPTOM:**
 - Engine stalls.
 - Idle mixture is out of specifications.

CAUTION:

After repair or replacement of faulty parts, conduct CLEAR MEMORY MODE <Ref. to 2-7 [T3D0].> and INSPECTION MODE <Ref. to 2-7 [T3E0].>

● **WIRING DIAGRAM:**

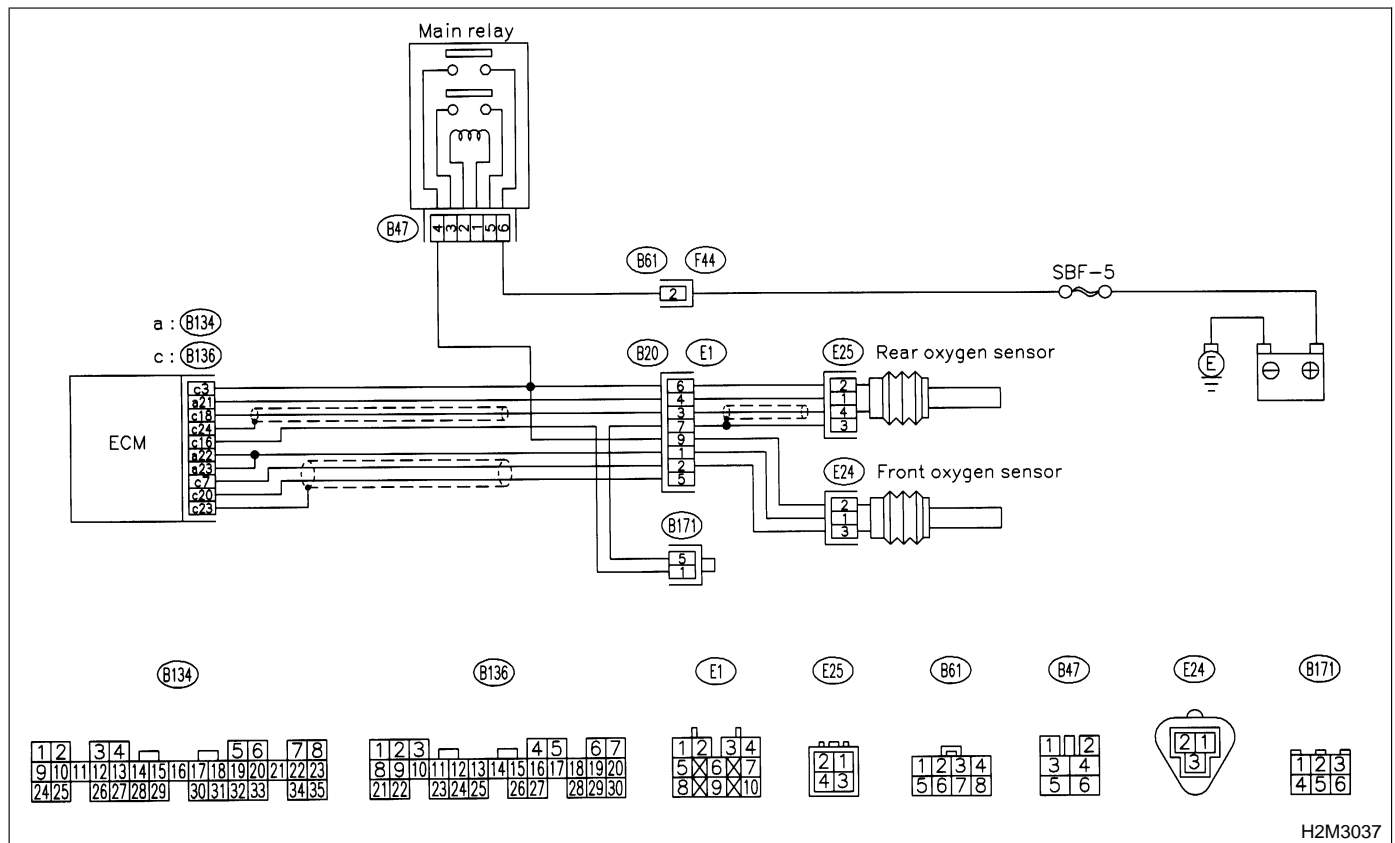

H2M3037

2-7 [T11AG1]

ON-BOARD DIAGNOSTICS II SYSTEM

11. Diagnostics Chart with Trouble Code for Except 2200 cc California Spec. Vehicles

11AG1 : CHECK ANY OTHER DTC ON DISPLAY.

CHECK : Does the Subaru Select Monitor or OBD-II general scan tool indicate DTC P0130, P0133, P0135, P0136, P0139, P0141, P0301, P0302, P0303, P0304, P1150 and P1151?

YES : Inspect the relevant DTC using "11. Diagnostics Chart with Trouble Code for Except 2200 cc California Spec. Vehicles". <Ref. to 2-7 [T11A0].>

NOTE:

In this case, it is not necessary to inspect DTC P0420.

NO : Go to step 11AG2.

11AG2 : CHECK EXHAUST SYSTEM.

Check for gas leaks or air suction caused by loose or dislocated nuts and bolts, and open hole at exhaust pipes.

NOTE:

Check the following positions.

- Between cylinder head and front exhaust pipe
- Between front exhaust pipe and front catalytic converter
- Between front catalytic converter and rear catalytic converter

CHECK : Is there a fault in exhaust system?

YES : Repair or replace exhaust system. <Ref. to 2-9 [W1A0].>

NO : Go to step 11AG3.

11AG3 : CHECK REAR CATALYTIC CONVERTER.

Separate rear catalytic converter from rear exhaust pipe.

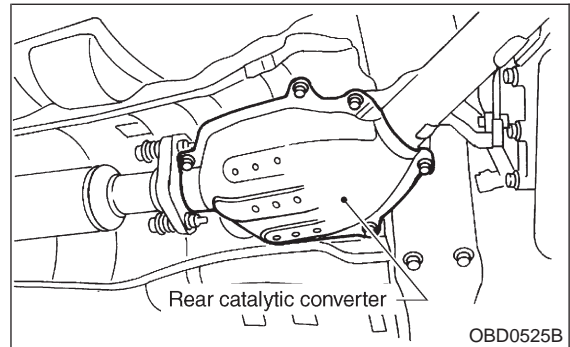

CHECK : Is there damage at rear face of rear catalyst?

YES : Replace front catalytic converter <Ref. to 2-1 [W1A0].> and rear catalytic converter <Ref. to 2-1 [W2A0].>

NO : Go to step 11AG4.

11AG4 : CHECK FRONT CATALYTIC CONVERTER.

Remove front catalytic converter.

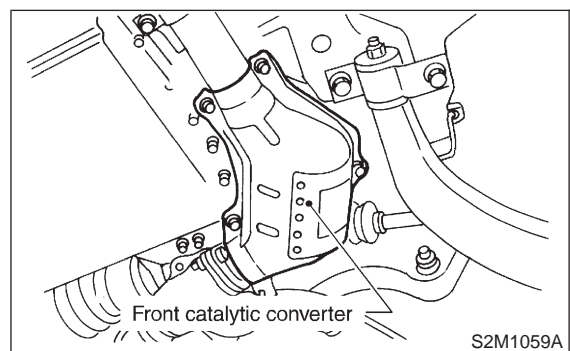

CHECK : Is there damage at rear face or front face of front catalyst?

YES : Replace front catalytic converter. <Ref. to 2-1 [W1A0].>

NO : Contact with SOA service.

NOTE:

Inspection by DTM is required, because probable cause is deterioration of multiple parts.

AH: DTC P0440 — EVAPORATIVE EMISSION CONTROL SYSTEM MALFUNCTION —

- **DTC DETECTING CONDITION:**
 - Two consecutive driving cycles with fault
- **TROUBLE SYMPTOM:**
 - Gasoline smell

CAUTION:

After repair or replacement of faulty parts, conduct **CLEAR MEMORY MODE** <Ref. to 2-7 [T3D0].> and **INSPECTION MODE** <Ref. to 2-7 [T3E0].>

● **WIRING DIAGRAM:**

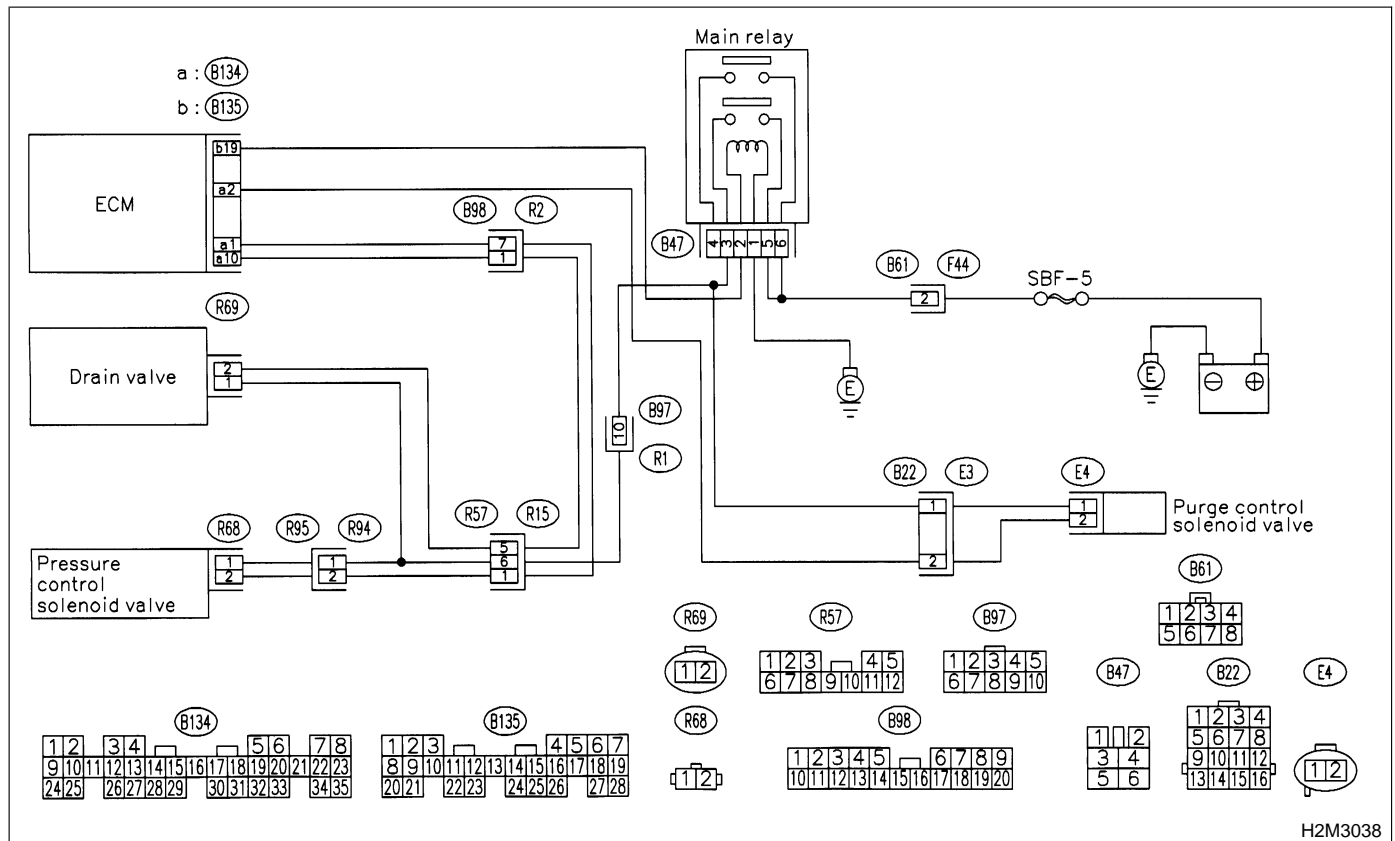

11AH1 : CHECK ANY OTHER DTC ON DISPLAY.

- CHECK** : *Is there any other DTC on display?*
- YES** : Inspect the relevant DTC using "11. Diagnostics Chart with Trouble Code for Except 2200 cc California Spec. Vehicles". <Ref. to 2-7 [T11A0].>
- NO** : Go to step **11AH2**.

11AH2 : CHECK FUEL FILLER CAP.

- 1) Turn ignition switch to OFF.
 - 2) Open the fuel flap.
- CHECK** : *Is the fuel filler cap tightened securely?*
 - YES** : Go to step **11AH3**.
 - NO** : Tighten fuel filler cap securely.

2-7 [T11AH3]

ON-BOARD DIAGNOSTICS II SYSTEM

11. Diagnostics Chart with Trouble Code for Except 2200 cc California Spec. Vehicles

11AH3 : CHECK FUEL FILLER PIPE PACKING.

CHECK : *Is there any damage to the seal between fuel filler cap and fuel filler pipe?*

YES : Repair or replace fuel filler cap and fuel filler pipe. <Ref. to 2-8 [W3A0].>

NO : Go to step 11AH4.

11AH4 : CHECK DRAIN VALVE OR VENT CONTROL SOLENOID VALVE.

1) Connect test mode connector.

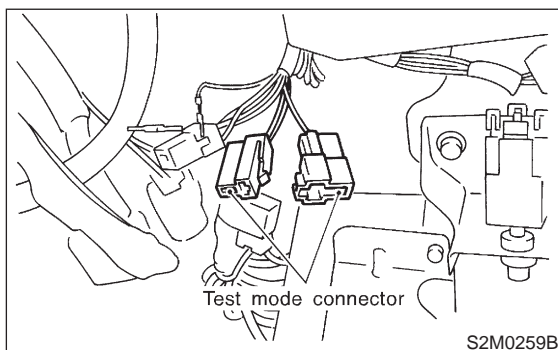

2) Turn ignition switch to ON.

NOTE:

Drain valve or vent control solenoid valve operation check can also be executed using Subaru Select Monitor. For the procedure, refer to "COMPULSORY VALVE OPERATION CHECK MODE". <Ref. to 2-7 [T3F0].>

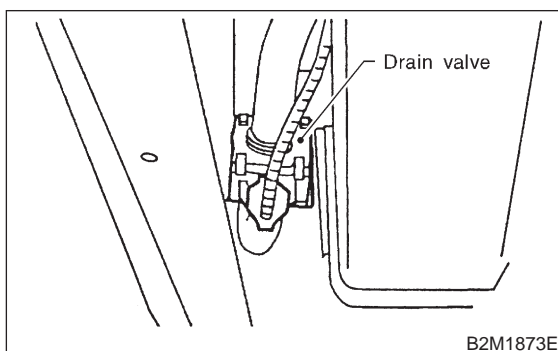

CHECK : *Does drain valve produce operating sound?*

YES : Go to step 11AH5.

NO : Replace drain valve. <Ref. to 2-1 [W13A0].>

11AH5 : CHECK PURGE CONTROL SOLENOID VALVE.

NOTE:

Purge control solenoid valve operation check can also be executed using Subaru Select Monitor. For the procedure, refer to "COMPULSORY VALVE OPERATION CHECK MODE". <Ref. to 2-7 [T3F0].>

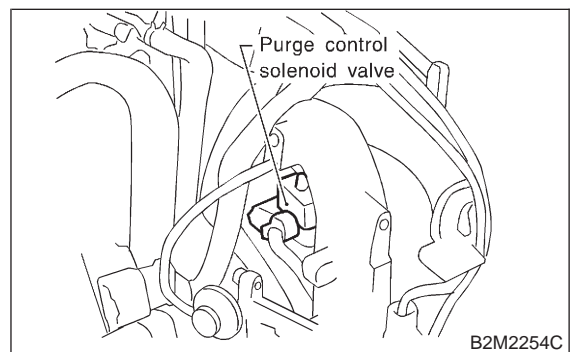

CHECK : *Does purge control solenoid valve produce operating sound?*

YES : Go to step 11AH6.

NO : Replace purge control solenoid valve. <Ref. to 2-1 [W4A0].>

11AH6 : CHECK PRESSURE CONTROL SOLENOID VALVE.

NOTE:

Pressure control solenoid valve operation check can also be executed using Subaru Select Monitor. For the procedure, refer to "COMPULSORY VALVE OPERATION CHECK MODE". <Ref. to 2-7 [T3F0].>

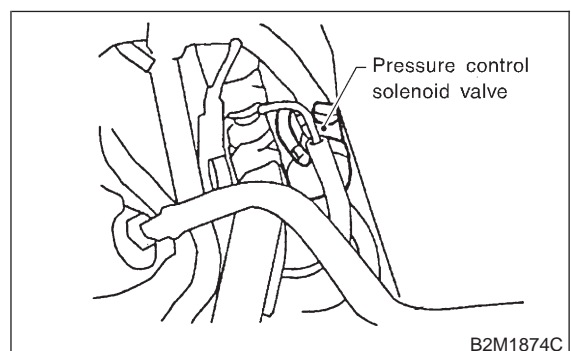

CHECK : *Does pressure control solenoid valve produce operating sound?*

YES : Go to step 11AH7.

NO : Replace pressure control solenoid valve. <Ref. to 2-1 [W7A0].>

11AH7 : CHECK EVAPORATIVE EMISSION CONTROL SYSTEM LINE.

Turn ignition switch to OFF.

- CHECK** : ***Does fuel leak in fuel line?***
YES : Repair or replace fuel line. <Ref. to 2-8 [W7A0].>
NO : Go to step 11AH8.

11AH8 : CHECK CANISTER.

- CHECK** : ***Is there any damage at canister?***
YES : Repair or replace canister. <Ref. to 2-1 [W3A0].>
NO : Go to step 11AH9.

11AH9 : CHECK FUEL TANK.

- CHECK** : ***Is there any damage at fuel tank?***
YES : Repair or replace fuel tank. <Ref. to 2-8 [W2A0].>
NO : Go to step 11AH10.

11AH10 : CHECK ANY OTHER MECHANICAL TROUBLE IN EVAPORATIVE EMISSION CONTROL SYSTEM.

- CHECK** : ***Are there holes, cracks, clogging or disconnections of hoses or pipes in evaporative emission control system?***
YES : Repair or replace hoses or pipes.
NO : Contact with SOA service.

NOTE:

Inspection by DTM is required, because probable cause is deterioration of multiple parts.

2-7 [T11AH10]

ON-BOARD DIAGNOSTICS II SYSTEM

11. Diagnostics Chart with Trouble Code for Except 2200 cc California Spec. Vehicles

MEMO:

AI: DTC P0443 — EVAPORATIVE EMISSION CONTROL SYSTEM PURGE CONTROL VALVE CIRCUIT LOW INPUT —

- **DTC DETECTING CONDITION:**
 - Two consecutive driving cycles with fault
- **TROUBLE SYMPTOM:**
 - Erroneous idling

CAUTION:

After repair or replacement of faulty parts, conduct CLEAR MEMORY MODE <Ref. to 2-7 [T3D0].> and INSPECTION MODE <Ref. to 2-7 [T3E0].>

● **WIRING DIAGRAM:**

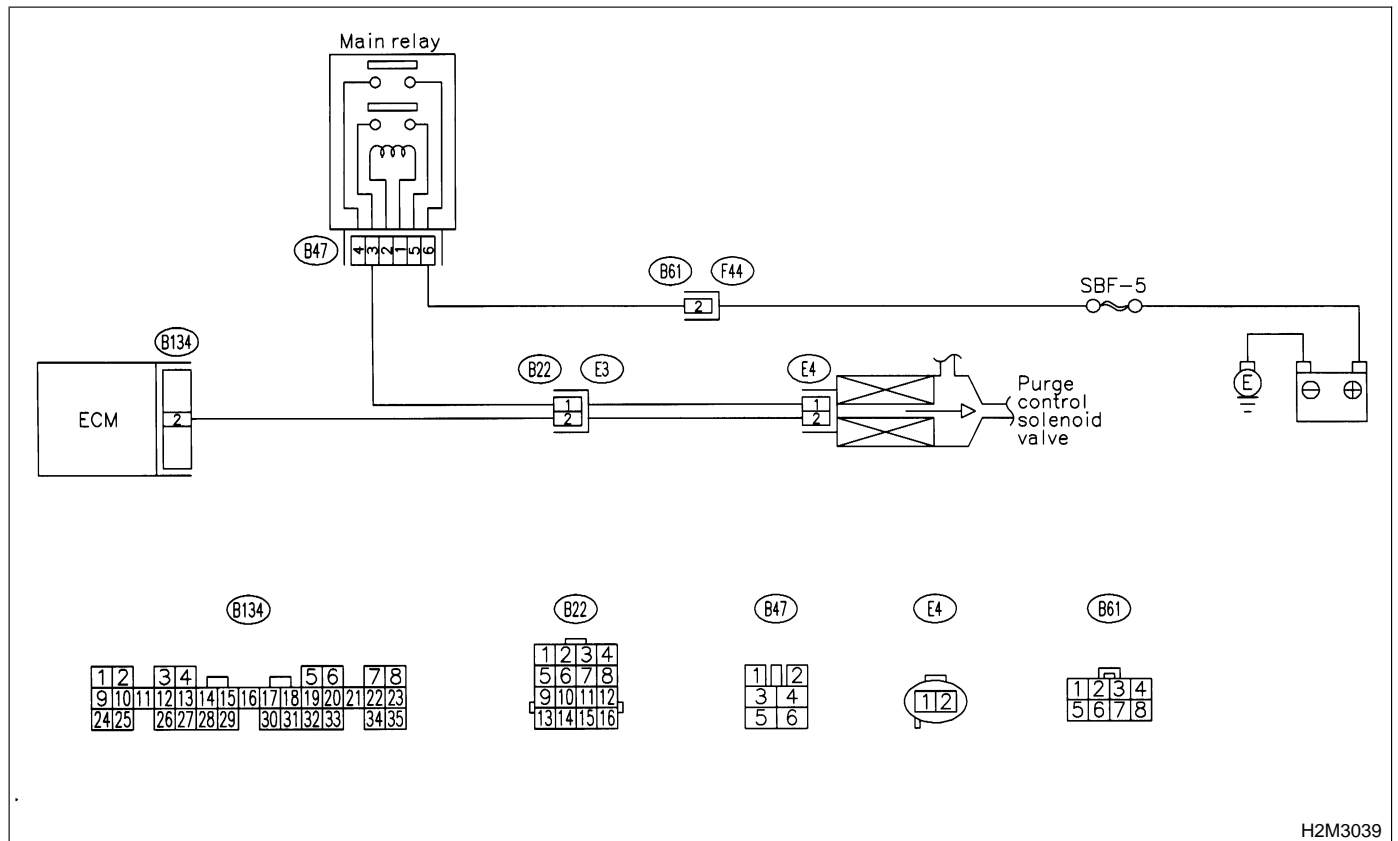

H2M3039

2-7 [T11A11]

ON-BOARD DIAGNOSTICS II SYSTEM

11. Diagnostics Chart with Trouble Code for Except 2200 cc California Spec. Vehicles

11A11 : CHECK OUTPUT SIGNAL FROM ECM.

- 1) Turn ignition switch to ON.
- 2) Measure voltage between ECM and chassis ground.

Connector & terminal
(B134) No. 2 (+) — Chassis ground (-):

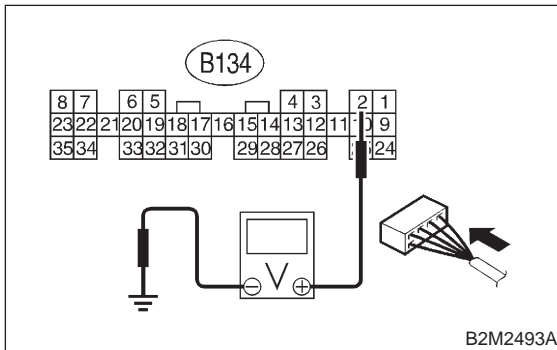

CHECK : **Is the voltage more than 10 V?**

YES : Even if MIL lights up, the circuit has returned to a normal condition at this time. Contact with SOA service.

NOTE:

Inspection by DTM is required, because probable cause is deterioration of multiple parts.

NO : Go to step **11A12**.

11A12 : CHECK HARNESS BETWEEN PURGE CONTROL SOLENOID VALVE AND ECM CONNECTOR.

- 1) Turn ignition switch to OFF.
- 2) Disconnect connectors from purge control solenoid valve and ECM.
- 3) Measure resistance of harness between purge control solenoid valve connector and engine ground.

Connector & terminal
(E4) No. 2 — Engine ground:

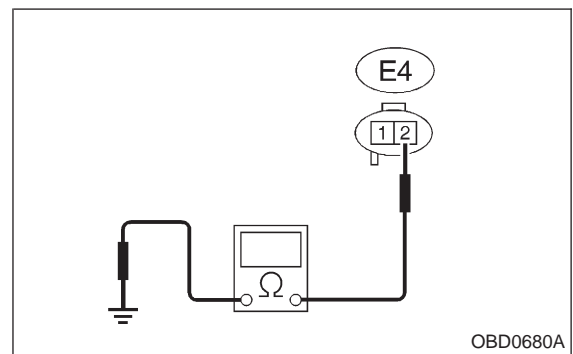

CHECK : **Is the resistance less than 10 Ω?**

YES : Repair ground short circuit in harness between ECM and purge control solenoid valve connector.

NO : Go to step **11A13**.

11A13 : CHECK HARNESS BETWEEN PURGE CONTROL SOLENOID VALVE AND ECM CONNECTOR.

Measure resistance of harness between ECM and purge control solenoid valve of harness connector.

Connector & terminal

(B134) No. 2 — (E4) No. 2:

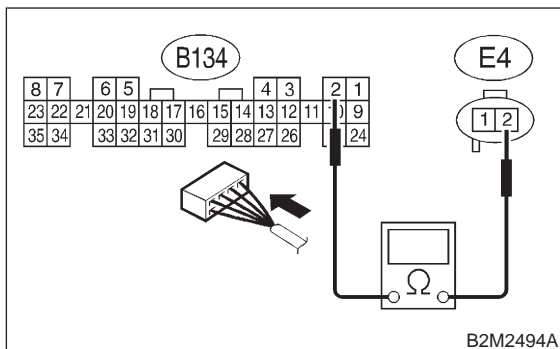

- CHECK** : Is the resistance less than 1 Ω?
- YES** : Go to step 11A14.
- NO** : Repair open circuit in harness between ECM and purge control solenoid valve connector.

NOTE:

In this case, repair the following:

- Open circuit in harness between ECM and purge control solenoid valve connector
- Poor contact in coupling connector (B22)

11A14 : CHECK PURGE CONTROL SOLENOID VALVE.

- 1) Remove purge control solenoid valve.
- 2) Measure resistance between purge control solenoid valve terminals.

Terminals

No. 1 — No. 2:

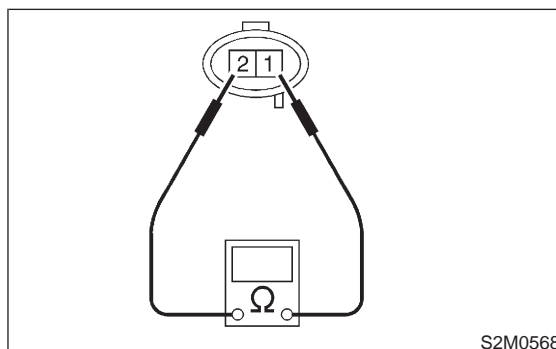

- CHECK** : Is the resistance between 10 and 100 Ω?
- YES** : Go to step 11A15.
- NO** : Replace purge control solenoid valve. <Ref. to 2-1 [W4A0].>

11A15 : CHECK POWER SUPPLY TO PURGE CONTROL SOLENOID VALVE.

- 1) Turn ignition switch to ON.
- 2) Measure voltage between purge control solenoid valve and engine ground.

Connector & terminal

(E4) No. 1 (+) — Engine ground (-):

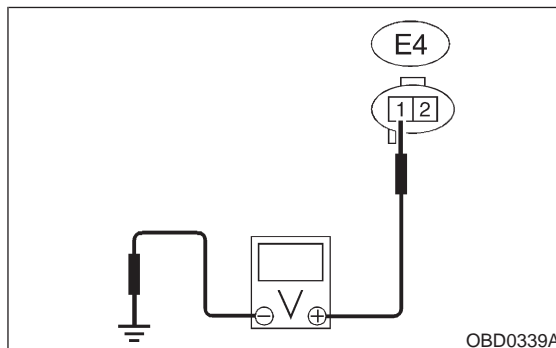

- CHECK** : Is the voltage more than 10 V?
- YES** : Go to step 11A16.
- NO** : Repair open circuit in harness between main relay and purge control solenoid valve connector.

2-7 [T11A16]

ON-BOARD DIAGNOSTICS II SYSTEM

11. Diagnostics Chart with Trouble Code for Except 2200 cc California Spec. Vehicles

11A16 : CHECK POOR CONTACT.

Check poor contact in purge control solenoid valve connector. <Ref. to FOREWORD [T3C1].>

CHECK : *Is there poor contact in purge control solenoid valve connector?*

YES : Repair poor contact in purge control solenoid valve connector.

NO : Contact with SOA service.

NOTE:

Inspection by DTM is required, because probable cause is deterioration of multiple parts.

AJ: DTC P0446 — EVAPORATIVE EMISSION CONTROL SYSTEM VENT CONTROL LOW INPUT —

- **DTC DETECTING CONDITION:**
 - Two consecutive driving cycles with fault

CAUTION:

After repair or replacement of faulty parts, conduct **CLEAR MEMORY MODE** <Ref. to 2-7 [T3D0].> and **INSPECTION MODE** <Ref. to 2-7 [T3E0].>

● **WIRING DIAGRAM:**

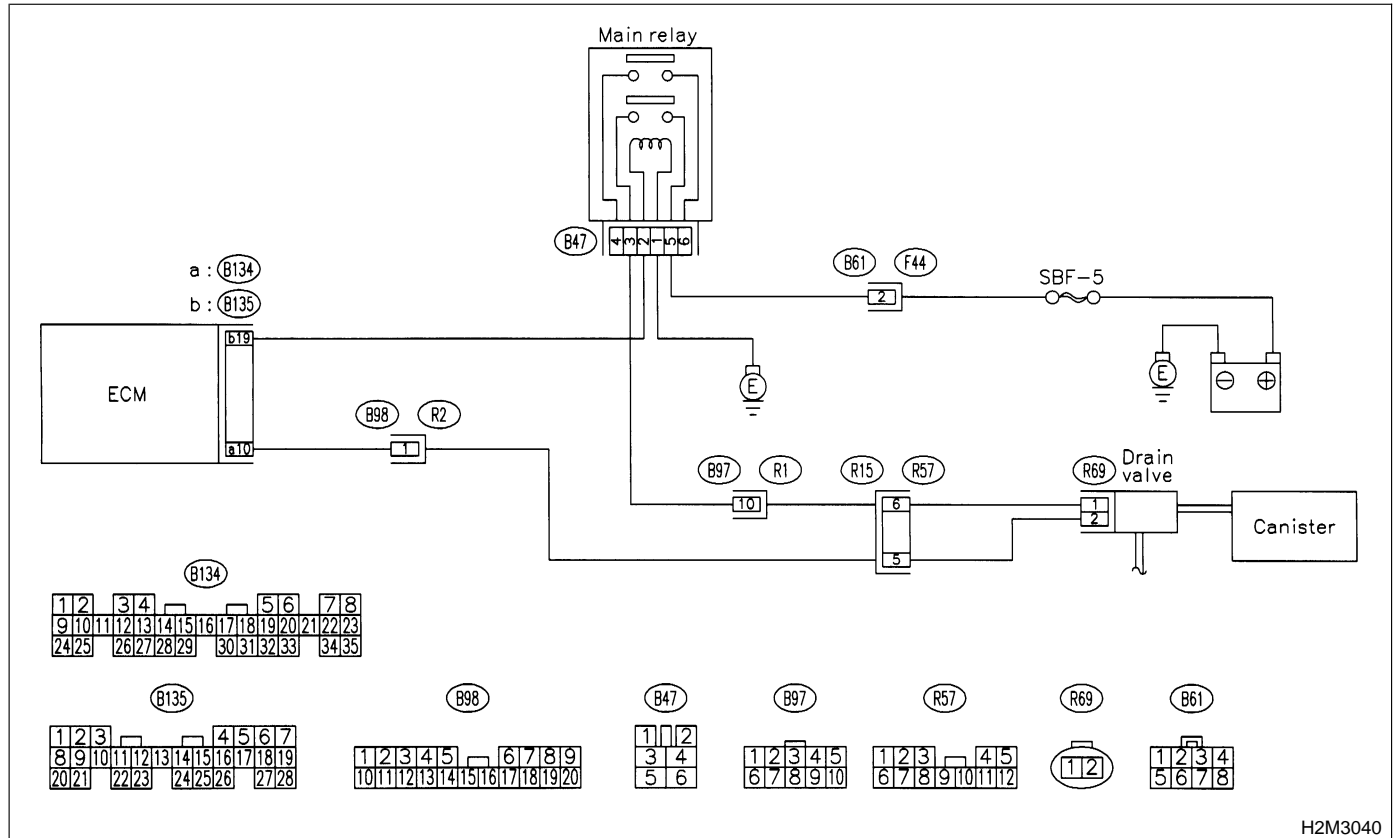

H2M3040

2-7 [T11AJ1]

ON-BOARD DIAGNOSTICS II SYSTEM

11. Diagnostics Chart with Trouble Code for Except 2200 cc California Spec. Vehicles

11AJ1 : CHECK OUTPUT SIGNAL FROM ECM.

- 1) Turn ignition switch to ON.
- 2) Measure voltage between ECM and chassis ground.

Connector & terminal

(B134) No. 10 (+) — Chassis ground (-):

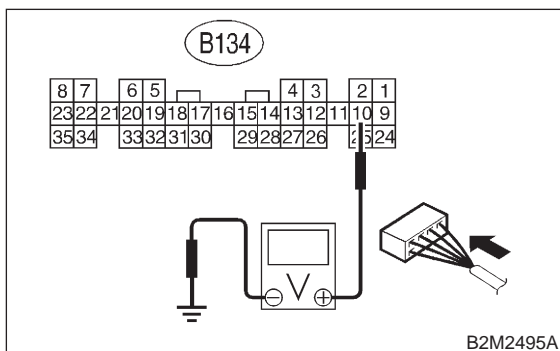

- CHECK** : Is the voltage more than 10 V?
- YES** : Go to step 11AJ2.
- NO** : Go to step 11AJ3.

11AJ2 : CHECK POOR CONTACT.

Check poor contact in ECM connector. <Ref. to FOREWORD [T3C1].>

- CHECK** : Is there poor contact in ECM connector?
- YES** : Repair poor contact in ECM connector.
- NO** : Even if MIL lights up, the circuit has returned to a normal condition at this time. (However, the possibility of poor contact still remains.)

NOTE:

In this case, repair the following:

- Poor contact in drain valve connector
- Poor contact in ECM connector
- Poor contact in coupling connectors (B97), (B98) and (R57)

11AJ3 : CHECK HARNESS BETWEEN DRAIN VALVE AND ECM CONNECTOR.

- 1) Turn ignition switch to OFF.
- 2) Disconnect connectors from drain valve and ECM.
- 3) Measure resistance of harness between drain valve connector and chassis ground.

Connector & terminal

(R69) No. 2 — Chassis ground:

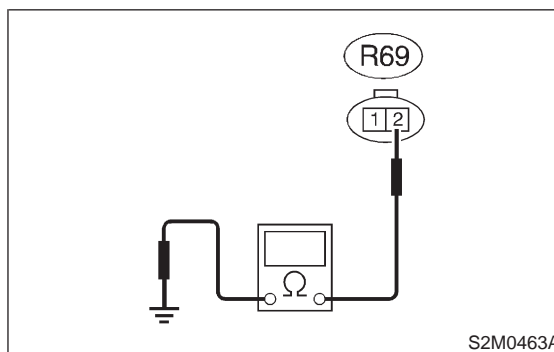

- CHECK** : Is the resistance less than 10 Ω?
- YES** : Repair ground short circuit in harness between ECM and drain valve connector.
- NO** : Go to step 11AJ4.

11AJ4 : CHECK HARNESS BETWEEN DRAIN VALVE AND ECM CONNECTOR.

Measure resistance of harness between ECM and drain valve connector.

Connector & terminal

(B134) No. 10 — (R69) No. 2:

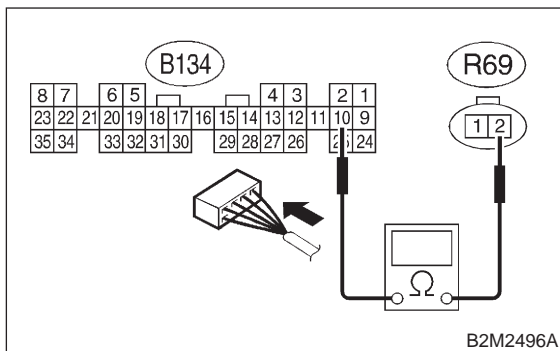

- CHECK** : Is the resistance less than 1 Ω?
- YES** : Go to step 11AJ5.
- NO** : Repair harness and connector.

NOTE:

In this case, repair the following:

- Open circuit in harness between ECM and drain valve connector
- Poor contact in coupling connectors (B98) and (R57)

11AJ5 : CHECK DRAIN VALVE.

Measure resistance between drain valve terminals.

Terminals

No. 1 — No. 2:

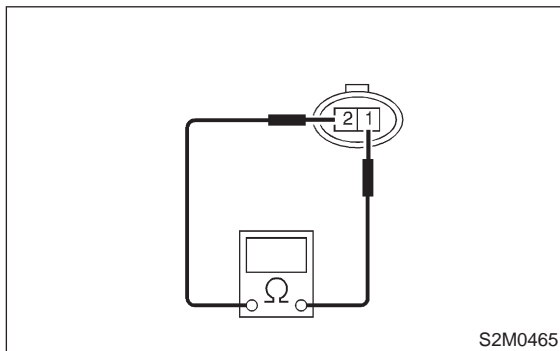

- CHECK** : Is the resistance between 10 and 100 Ω?
- YES** : Go to step 11AJ6.
- NO** : Replace drain valve. <Ref. to 2-1 [W13A0].>

11AJ6 : CHECK POWER SUPPLY TO DRAIN VALVE.

- 1) Turn ignition switch to ON.
- 2) Measure voltage between drain valve and chassis ground.

Connector & terminal

(R69) No. 1 (+) — Chassis ground (-):

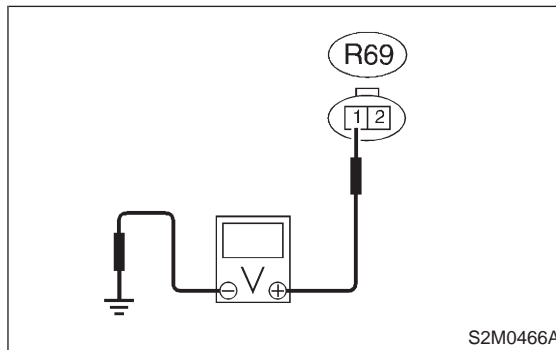

- CHECK** : Is the voltage more than 10 V?
- YES** : Go to step 11AJ7.
- NO** : Repair harness and connector.

NOTE:

In this case, repair the following:

- Open circuit in harness between main relay and drain valve
- Poor contact in coupling connectors (B97) and (R57)
- Poor contact in main relay connector

11AJ7 : CHECK POOR CONTACT.

Check poor contact in drain valve connector. <Ref. to FOREWORD [T3C1].>

- CHECK** : Is there poor contact in drain valve connector?
- YES** : Repair poor contact in drain valve connector.
- NO** : Contact with SOA service.

NOTE:

Inspection by DTM is required, because probable cause is deterioration of multiple parts.

2-7 [T11AJ7]

ON-BOARD DIAGNOSTICS II SYSTEM

11. Diagnostics Chart with Trouble Code for Except 2200 cc California Spec. Vehicles

MEMO:

AK: DTC P0451 — EVAPORATIVE EMISSION CONTROL SYSTEM PRESSURE SENSOR RANGE/PERFORMANCE PROBLEM —

- **DTC DETECTING CONDITION:**
 - Two consecutive driving cycles with fault

CAUTION:

After repair or replacement of faulty parts, conduct **CLEAR MEMORY MODE** <Ref. to 2-7 [T3D0].> and **INSPECTION MODE** <Ref. to 2-7 [T3E0].>

● **WIRING DIAGRAM:**

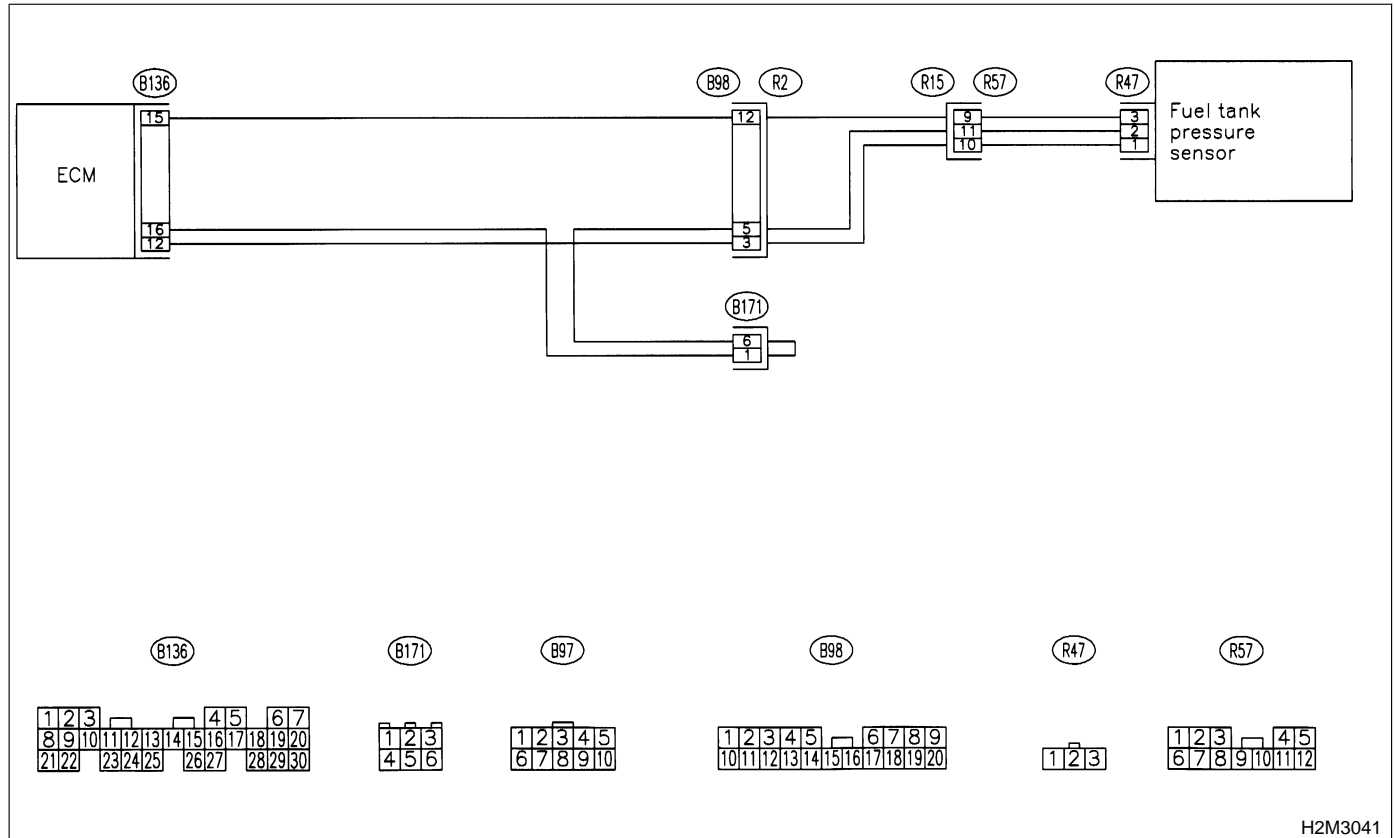

H2M3041

11AK1 : CHECK ANY OTHER DTC ON DISPLAY.

- CHECK** : *Is there any DTC on display?*
- YES** : Inspect the relevant DTC using "11. Diagnostics Chart with Trouble Code for Except 2200 cc California Spec. Vehicles". <Ref. to 2-7 [T11A0].>
- NO** : Go to step **11AK2**.

11AK2 : CHECK FUEL FILLER CAP.

- 1) Turn ignition switch to OFF.
 - 2) Open the fuel flap.
- CHECK** : *Is the fuel filler cap tightened securely?*
 - YES** : Go to step **11AK3**.
 - NO** : Tighten fuel filler cap securely.

**11AK3 : CHECK PRESSURE/VACUUM
LINE.**

NOTE:

Check the following items.

- Disconnection, leakage and clogging of the vacuum hoses and pipes between fuel tank pressure sensor and fuel tank
- Disconnection, leakage and clogging of air ventilation hoses and pipes between fuel filler pipe and fuel tank

CHECK : *Is there a fault in pressure/vacuum line?*

YES : Repair or replace hoses and pipes.

NO : Replace fuel tank pressure sensor.
<Ref. to 2-1 [W6A0].>

AL: DTC P0452 — EVAPORATIVE EMISSION CONTROL SYSTEM PRESSURE SENSOR LOW INPUT —

- **DTC DETECTING CONDITION:**
 - Immediately at fault recognition

CAUTION:

After repair or replacement of faulty parts, conduct **CLEAR MEMORY MODE** <Ref. to 2-7 [T3D0].> and **INSPECTION MODE** <Ref. to 2-7 [T3E0].>

- **WIRING DIAGRAM:**

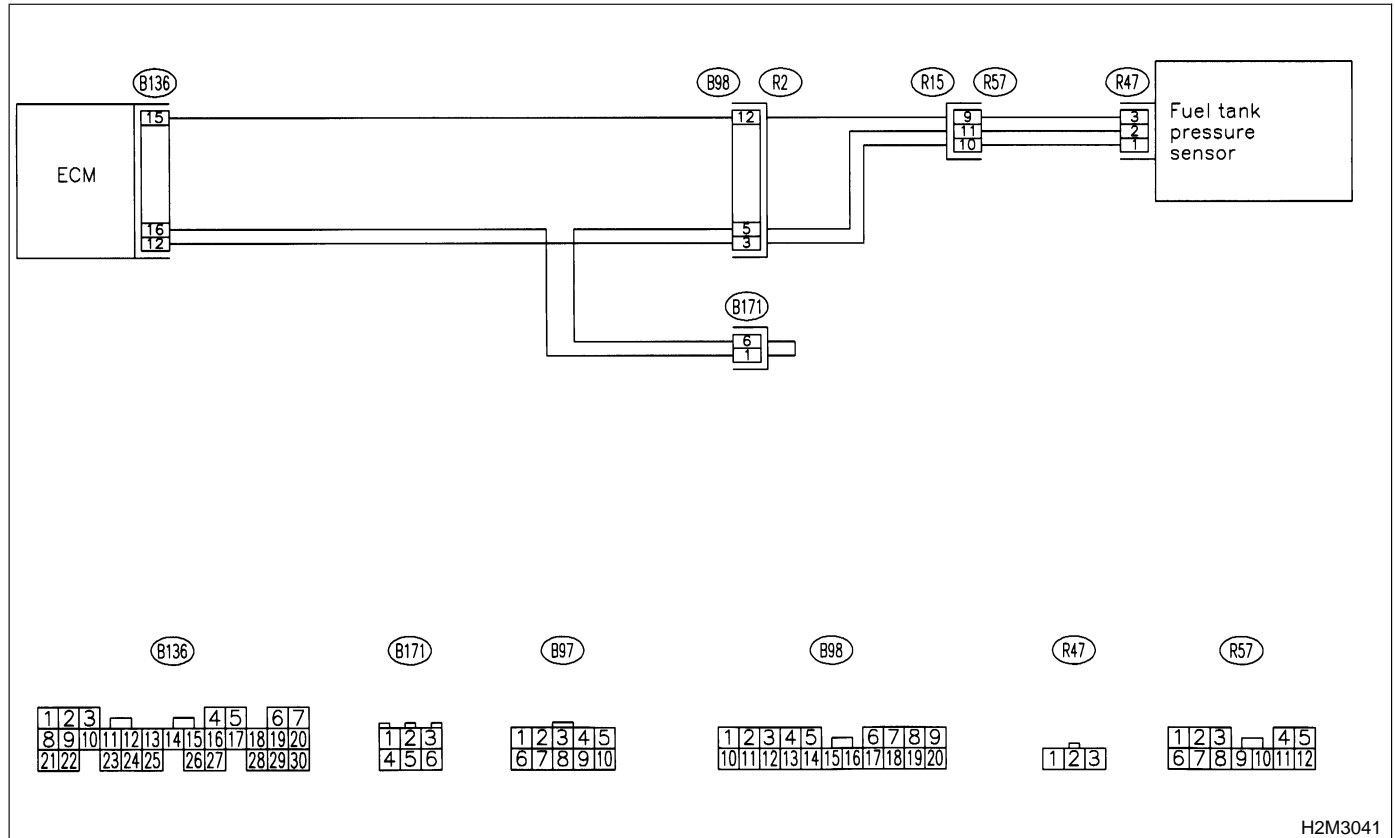

H2M3041

2-7 [T11A1]

ON-BOARD DIAGNOSTICS II SYSTEM

11. Diagnostics Chart with Trouble Code for Except 2200 cc California Spec. Vehicles

11A1 : CONNECT SUBARU SELECT MONITOR OR THE OBD-II GENERAL SCAN TOOL, AND READ DATA.

- 1) Turn ignition switch to OFF.
- 2) Remove fuel filler cap.
- 3) Install fuel filler cap.
- 4) Connect Subaru Select Monitor or the OBD-II general scan tool to data link connector.

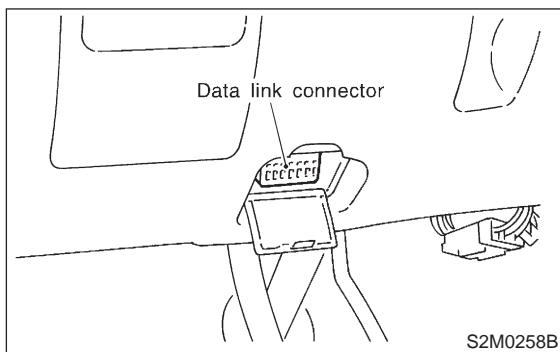

- 5) Turn ignition switch to ON and Subaru Select Monitor or the OBD-II general scan tool switch to ON.
- 6) Read the data of fuel tank pressure sensor signal using Subaru Select Monitor or the OBD-II general scan tool.

NOTE:

- Subaru Select Monitor
For detailed operation procedure, refer to the "READ CURRENT DATA SHOWN ON DISPLAY FOR ENGINE". <Ref. to 2-7 [T3C4].>
- OBD-II general scan tool
For detailed operation procedures, refer to the OBD-II General Scan Tool Instruction Manual.

- CHECK** : *Is the value less than -2.8 kPa (-21.0 mmHg, -0.827 inHg)?*
- YES** : Go to step 11A2.
- NO** : Even if MIL lights up, the circuit has returned to a normal condition at this time.

11A2 : CHECK POWER SUPPLY TO FUEL TANK PRESSURE SENSOR.

Measure voltage between ECM connector and chassis ground.

Connector & terminal
(B136) No. 15 (+) — Chassis ground (-):

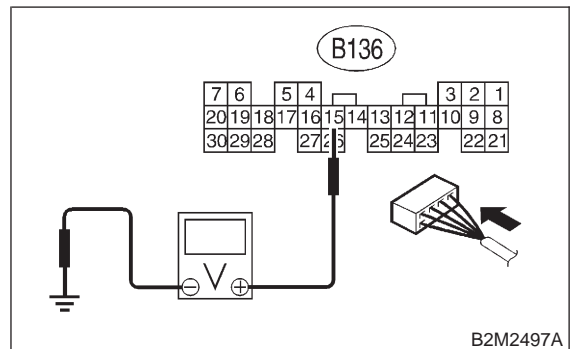

- CHECK** : *Is the voltage more than 4.5 V?*
- YES** : Go to step 11A4.
- NO** : Go to step 11A3.

11A3 : CHECK POWER SUPPLY TO FUEL TANK PRESSURE SENSOR.

Measure voltage between ECM connector and chassis ground.

Connector & terminal
(B136) No. 15 (+) — Chassis ground (-):

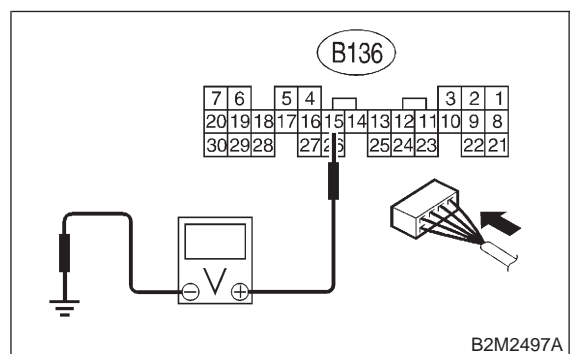

- CHECK** : *Does the voltage change more than 4.5 V by shaking harness and connector of ECM while monitoring the value with voltage meter?*
- YES** : Repair poor contact in ECM connector.
- NO** : Contact with SOA service.

NOTE:

Inspection by DTM is required, because probable cause is deterioration of multiple parts.

11AL4 : CHECK INPUT SIGNAL FOR ECM.

Measure voltage between ECM and chassis ground.

Connector & terminal
(B136) No. 12 (+) — Chassis ground (-):

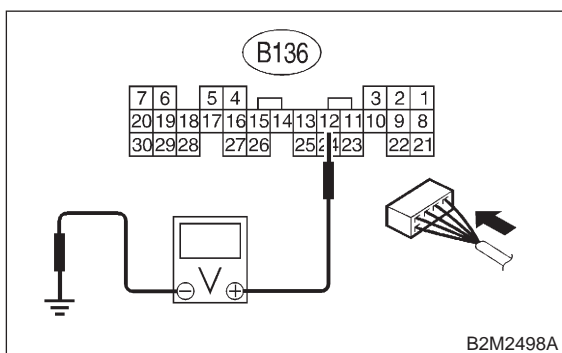

- CHECK** : *Is the voltage less than 0.2 V?*
- YES** : Go to step 11AL6.
- NO** : Go to step 11AL5.

11AL5 : CHECK INPUT SIGNAL FOR ECM. (USING SUBARU SELECT MONITOR.)

Read data of fuel tank pressure sensor signal using Subaru Select Monitor.

NOTE:

- Subaru Select Monitor
- For detailed operation procedure, refer to the "READ CURRENT DATA SHOWN ON DISPLAY FOR ENGINE". <Ref. to 2-7 [T3C4].>

- CHECK** : *Does the value change more than -2.8 kPa (-21.0 mmHg, -0.827 inHg) by shaking harness and connector of ECM while monitoring the value with Subaru Select Monitor?*
- YES** : Repair poor contact in ECM connector.
- NO** : Go to step 11AL6.

11AL6 : CHECK HARNESS BETWEEN ECM AND COUPLING CONNECTOR IN REAR WIRING HARNESS.

- 1) Turn ignition switch to OFF.
- 2) Remove rear seat cushion (Sedan) or move rear seat cushion (Wagon).
- 3) Separate rear wiring harness and fuel tank cord.
- 4) Turn ignition switch to ON.
- 5) Measure voltage between rear wiring harness connector and chassis ground.

Connector & terminal
(R83) No. 1 (+) — Chassis ground (-):

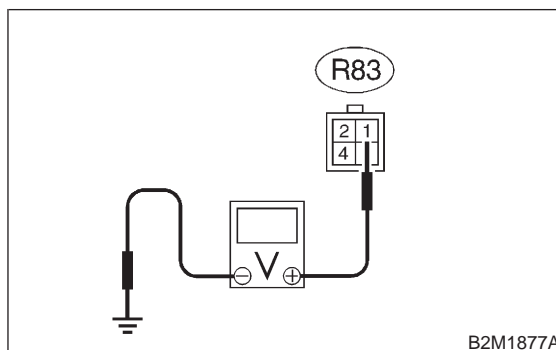

- CHECK** : *Is the voltage more than 4.5 V?*
- YES** : Go to step 11AL7.
- NO** : Repair harness and connector.

NOTE:

- In this case, repair the following:
- Open circuit in harness between ECM and rear wiring harness connector (R83)
 - Poor contact in coupling connector (B98)

2-7 [T11AL7]

ON-BOARD DIAGNOSTICS II SYSTEM

11. Diagnostics Chart with Trouble Code for Except 2200 cc California Spec. Vehicles

11AL7 : CHECK HARNESS BETWEEN ECM AND COUPLING CONNECTOR IN REAR WIRING HARNESS.

- 1) Turn ignition switch to OFF.
- 2) Disconnect connector from ECM.
- 3) Measure resistance of harness between ECM and rear wiring harness connector.

Connector & terminal

(B136) No. 16 — (R15) No. 11:

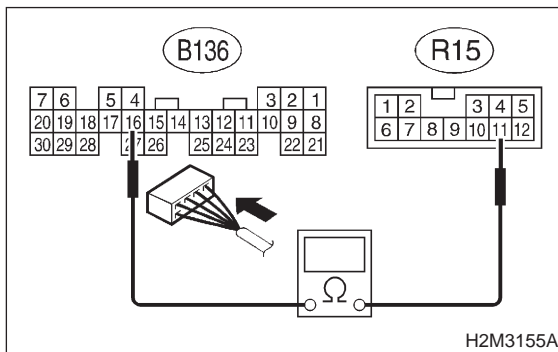

- CHECK** : Is the resistance less than 1 Ω?
- YES** : Go to step 11AL8.
- NO** : Repair harness and connector.

NOTE:

In this case, repair the following:

- Open circuit in harness between ECM and rear wiring harness connector (R15)
- Poor contact in coupling connector (B98)

11AL8 : CHECK HARNESS BETWEEN ECM AND COUPLING CONNECTOR IN REAR WIRING HARNESS.

Measure resistance of harness between rear wiring harness connector and chassis ground.

Connector & terminal

(R15) No. 11 — Chassis ground:

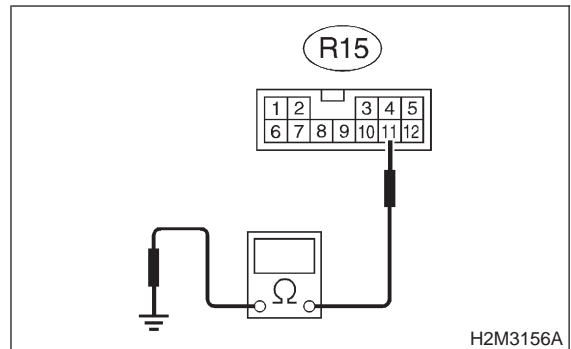

- CHECK** : Is the resistance more than 500 kΩ?
- YES** : Go to step 11AL9.
- NO** : Repair ground short circuit in harness between ECM and rear wiring harness connector (R15).

11AL9 : CHECK FUEL TANK CORD.

- 1) Remove fuel tank. <Ref. to 2-8 [W2A0].>
- 2) Disconnect connector from fuel tank pressure sensor.
- 3) Measure resistance of fuel tank cord.

Connector & terminal

(R15) No. 9 — (R47) No. 3:

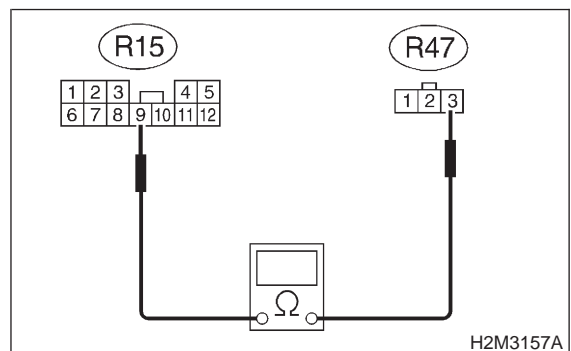

- CHECK** : Is the resistance less than 1 Ω?
- YES** : Go to step 11AL10.
- NO** : Repair open circuit in fuel tank cord.

11AL10 : CHECK FUEL TANK CORD.

Measure resistance of fuel tank cord.

Connector & terminal

(R57) No. 10 — (R47) No. 1:

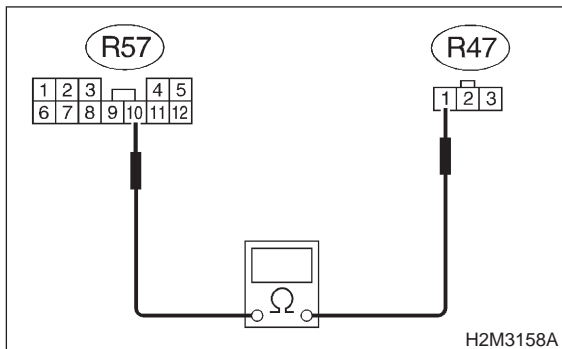

- CHECK** : **Is the resistance less than 1 Ω?**
- YES** : Go to step 11AL11.
- NO** : Repair open circuit in fuel tank cord.

11AL11 : CHECK FUEL TANK CORD.

Measure resistance of harness between fuel tank pressure sensor connector and chassis ground.

Connector & terminal

(R47) No. 2 — Chassis ground:

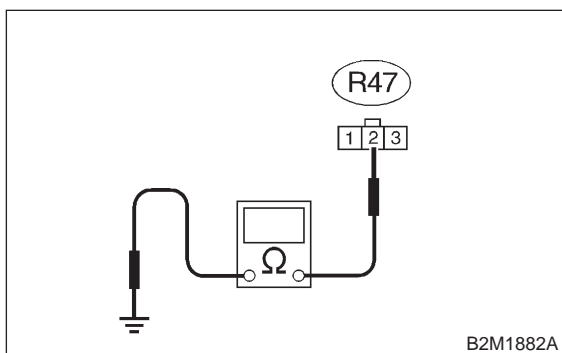

- CHECK** : **Is the resistance more than 500 kΩ?**
- YES** : Go to step 11AL12.
- NO** : Repair ground short circuit in fuel tank cord.

11AL12 : CHECK POOR CONTACT.

Check poor contact in fuel tank pressure sensor connector. <Ref. to FOREWORD [T3C1].>

- CHECK** : **Is there poor contact in fuel tank pressure sensor connector?**
- YES** : Repair poor contact in fuel tank pressure sensor connector.
- NO** : Replace fuel tank pressure sensor. <Ref. to 2-1 [W6A0].>

MEMO:

AM: DTC P0453 — EVAPORATIVE EMISSION CONTROL SYSTEM PRESSURE SENSOR HIGH INPUT —

- **DTC DETECTING CONDITION:**
 - Immediately at fault recognition

CAUTION:

After repair or replacement of faulty parts, conduct **CLEAR MEMORY MODE** <Ref. to 2-7 [T3D0].> and **INSPECTION MODE** <Ref. to 2-7 [T3E0].>

- **WIRING DIAGRAM:**

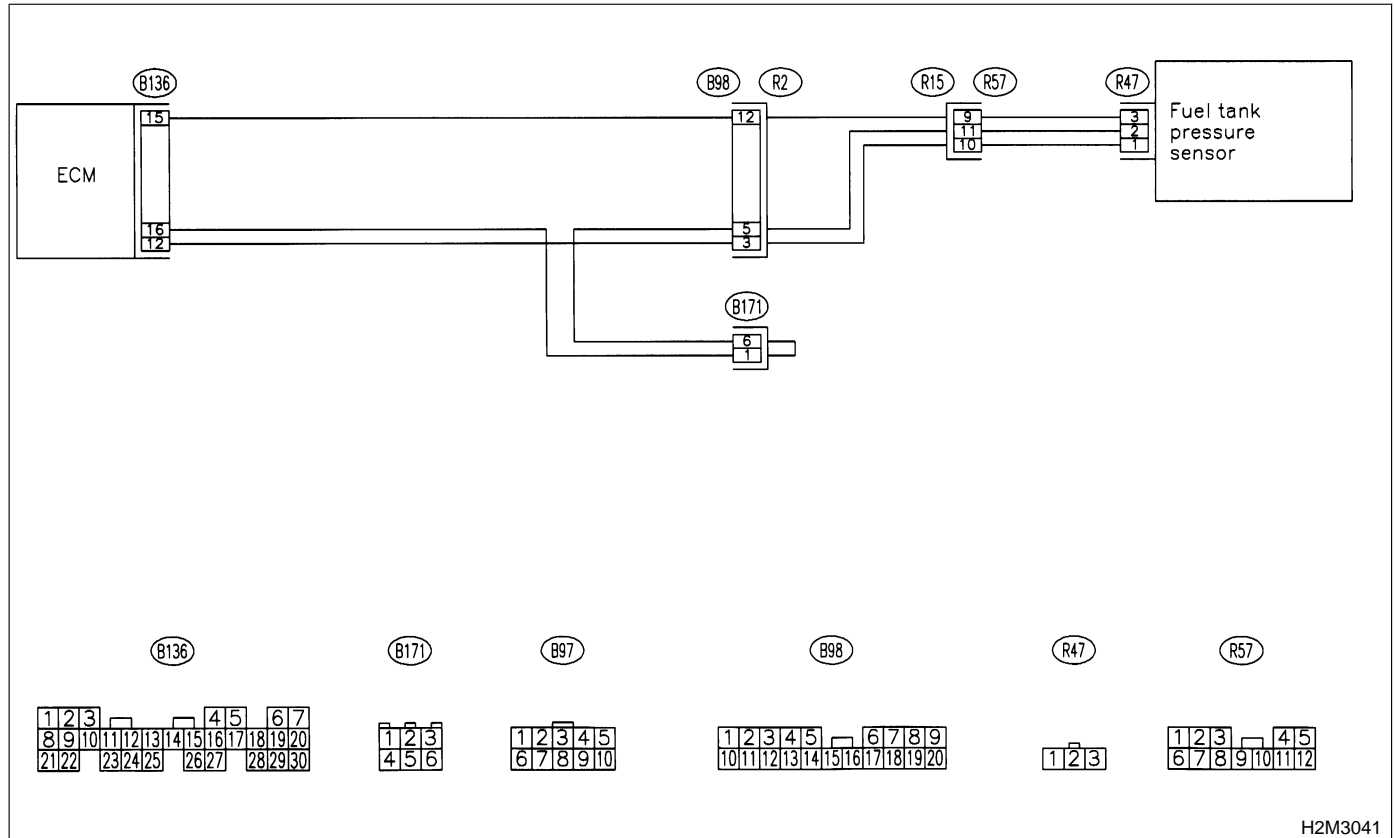

H2M3041

2-7 [T11AM1]

ON-BOARD DIAGNOSTICS II SYSTEM

11. Diagnostics Chart with Trouble Code for Except 2200 cc California Spec. Vehicles

11AM1 : CONNECT SUBARU SELECT MONITOR OR THE OBD-II GENERAL SCAN TOOL, AND READ DATA.

- 1) Turn ignition switch to OFF.
- 2) Remove fuel filler cap.
- 3) Install fuel filler cap.
- 4) Connect Subaru Select Monitor or the OBD-II general scan tool to data link connector.

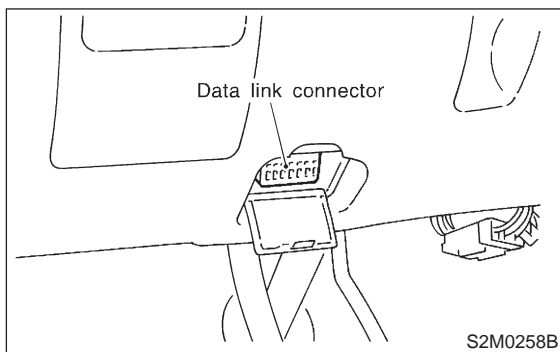

- 5) Turn ignition switch to ON and Subaru Select Monitor or the OBD-II general scan tool switch to ON.
- 6) Read data of fuel tank pressure sensor signal using Subaru Select Monitor or OBD-II general scan tool.

NOTE:

- Subaru Select Monitor
For detailed operation procedure, refer to the "READ CURRENT DATA SHOWN ON DISPLAY FOR ENGINE". <Ref. to 2-7 [T3C4].>
- OBD-II general scan tool
For detailed operation procedures, refer to the OBD-II General Scan Tool Instruction Manual.

- CHECK** : *Is the value more than 2.8 kPa (21.0 mmHg, 0.827 inHg)?*
- YES** : Go to step 11AM12.
- NO** : Go to step 11AM2.

11AM2 : CHECK POWER SUPPLY TO FUEL TANK PRESSURE SENSOR.

Measure voltage between ECM connector and chassis ground.

Connector & terminal
(B136) No. 15 (+) — Chassis ground (-):

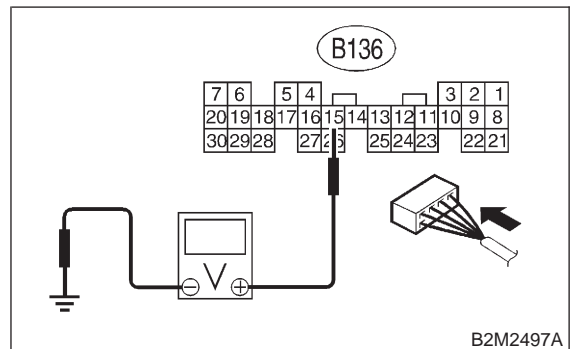

- CHECK** : *Is the voltage more than 4.5 V?*
- YES** : Go to step 11AM4.
- NO** : Go to step 11AM3.

11AM3 : CHECK POWER SUPPLY TO FUEL TANK PRESSURE SENSOR.

Measure voltage between ECM connector and chassis ground.

Connector & terminal
(B136) No. 15 (+) — Chassis ground (-):

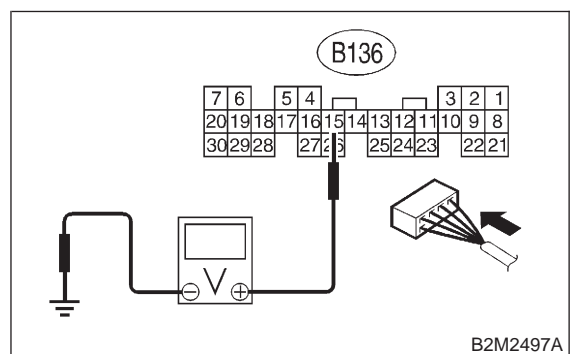

- CHECK** : *Does the voltage change more than 4.5 V by shaking harness and connector of ECM while monitoring the value with voltage meter?*
- YES** : Repair poor contact in ECM connector.
- NO** : Replace ECM. <Ref. to 2-7 [W15A0].>

11AM4 : CHECK INPUT SIGNAL FOR ECM.

Measure voltage between ECM and chassis ground.

Connector & terminal
(B136) No. 12 (+) — Chassis ground (-):

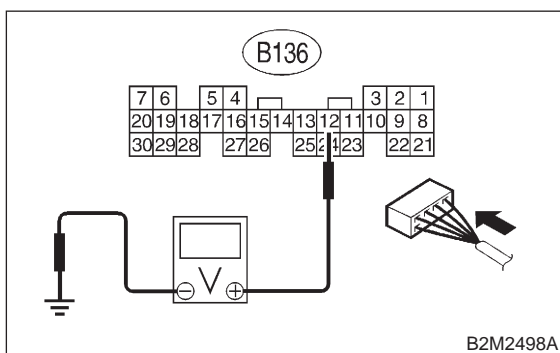

- CHECK** : Is the voltage less than 0.2 V?
- YES** : Go to step 11AM6.
- NO** : Go to step 11AM5.

11AM5 : CHECK INPUT SIGNAL FOR ECM. (USING SUBARU SELECT MONITOR.)

Read data of fuel tank pressure sensor signal using Subaru Select Monitor.

NOTE:

- Subaru Select Monitor
- For detailed operation procedure, refer to the "READ CURRENT DATA SHOWN ON DISPLAY FOR ENGINE". <Ref. to 2-7 [T3C4].>

- CHECK** : Does the value change more than **-2.8 kPa (-21.0 mmHg, -0.827 inHg)** by shaking harness and connector of ECM while monitoring the value with Subaru Select Monitor?
- YES** : Repair poor contact in ECM connector.
- NO** : Go to step 11AM6.

11AM6 : CHECK HARNESS BETWEEN ECM AND COUPLING CONNECTOR IN REAR WIRING HARNESS.

- 1) Turn ignition switch to OFF.
- 2) Remove rear seat cushion (Sedan) or move rear seat cushion (Wagon).
- 3) Separate rear wiring harness and fuel tank cord.
- 4) Turn ignition switch to ON.
- 5) Measure voltage between rear wiring harness connector and chassis ground.

Connector & terminal
(R15) No. 9 (+) — Chassis ground (-):

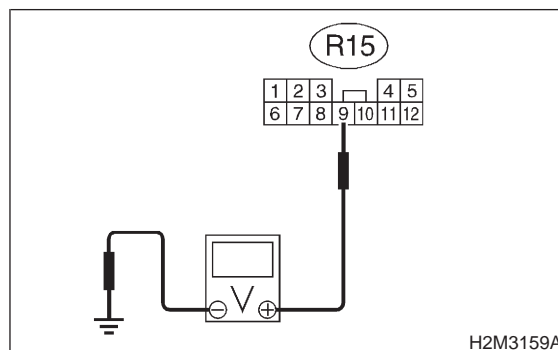

- CHECK** : Is the voltage more than 4.5 V?
- YES** : Go to step 11AM7.
- NO** : Repair harness and connector.

NOTE:

- In this case, repair the following:
- Open circuit in harness between ECM and rear wiring harness connector (R15)
 - Poor contact in coupling connector (B98)

11AM7 : CHECK HARNESS BETWEEN ECM AND COUPLING CONNECTOR IN REAR WIRING HARNESS.

- 1) Turn ignition switch to OFF.
- 2) Disconnect connector from ECM.
- 3) Measure resistance of harness between ECM and rear wiring harness connector.

Connector & terminal

(B136) No. 12 — (R15) No. 10:

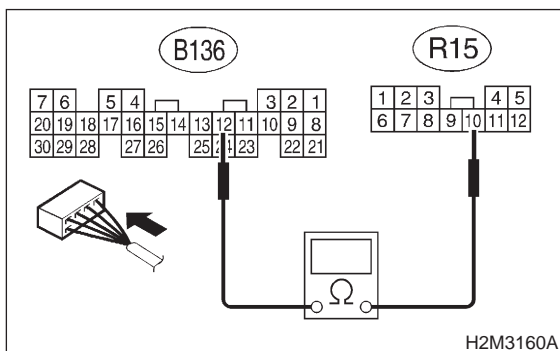

- CHECK** : Is the resistance less than 1 Ω?
- YES** : Go to step 11AM8.
- NO** : Repair harness and connector.

NOTE:

In this case, repair the following:

- Open circuit in harness between ECM and rear wiring harness connector (R15)
- Poor contact in coupling connector (B98)

11AM8 : CHECK HARNESS BETWEEN ECM AND COUPLING CONNECTOR IN REAR WIRING HARNESS.

Measure resistance of harness between rear wiring harness connector and chassis ground.

Connector & terminal

(B136) No. 16 — (R15) No. 11:

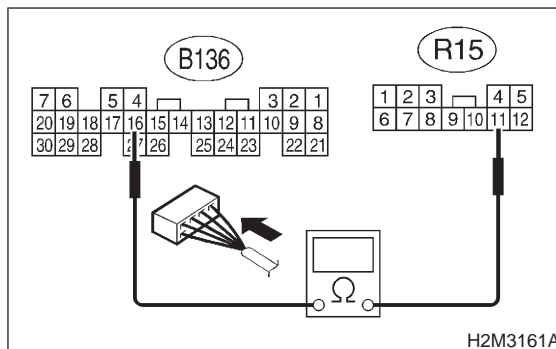

- CHECK** : Is the resistance less than 1 Ω?
- YES** : Go to step 11AM9.
- NO** : Repair ground short circuit in harness between ECM and rear wiring harness connector (R83).

11AM9 : CHECK FUEL TANK CORD.

- 1) Remove fuel tank. <Ref. to 2-8 [W2A0].>
- 2) Disconnect connector from fuel tank pressure sensor.
- 3) Measure resistance of fuel tank cord.

Connector & terminal

(R15) No. 11 — (R47) No. 2:

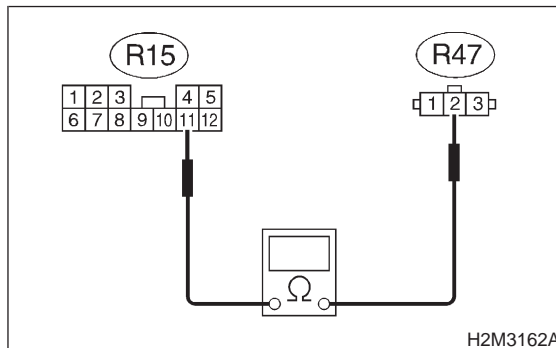

- CHECK** : Is the resistance less than 1 Ω?
- YES** : Go to step 11AM10.
- NO** : Repair open circuit in fuel tank cord.

11AM10 : CHECK FUEL TANK CORD.

Measure resistance of fuel tank cord.

Connector & terminal

(R57) No. 10 — (R47) No. 1:

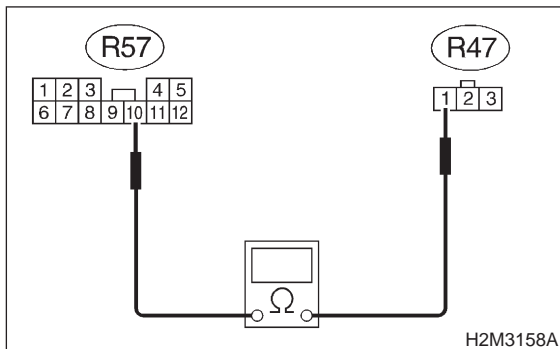

- CHECK** : *Is the resistance less than 1 Ω?*
- YES** : Go to step 11AM11.
- NO** : Repair open circuit in fuel tank cord.

11AM11 : CHECK POOR CONTACT.

Check poor contact in fuel tank pressure sensor connector. <Ref. to FOREWORD [T3C1].>

- CHECK** : *Is there poor contact in fuel tank pressure sensor connector?*
- YES** : Repair poor contact in fuel tank pressure sensor connector.
- NO** : Replace fuel tank pressure sensor. <Ref. to 2-1 [W6A0].>

11AM12 : CHECK HARNESS BETWEEN ECM AND FUEL TANK PRESSURE SENSOR CONNECTOR.

- 1) Turn ignition switch to OFF and Subaru Select Monitor or the OBD-II general scan tool switch to OFF.
- 2) Remove fuel tank. <Ref. to 2-8 [W2A0].>
- 3) Remove fuel tank cord from fuel tank.
- 4) Connect fuel tank cord to rear wiring harness.
- 5) Remove fuel filler cap.
- 6) Install fuel filler cap.
- 7) Turn ignition switch to ON and Subaru Select Monitor or the OBD-II general scan tool switch to ON.
- 8) Read data of fuel tank pressure sensor signal using Subaru Select Monitor or the OBD-II general scan tool.

NOTE:

- Subaru Select Monitor
For detailed operation procedure, refer to the "READ CURRENT DATA SHOWN ON DISPLAY FOR ENGINE". <Ref. to 2-7 [T3C4].>
- OBD-II general scan tool
For detailed operation procedures, refer to the OBD-II General Scan Tool Instruction Manual.

- CHECK** : *Is the value more than 2.8 kPa (21.0 mmHg, 0.827 inHg)?*
- YES** : Repair battery short circuit in harness between ECM and fuel tank pressure sensor connector.
- NO** : Replace fuel tank pressure sensor. <Ref. to 2-1 [W6A0].>

AN: DTC P0461 — FUEL LEVEL SENSOR CIRCUIT RANGE/ PERFORMANCE PROBLEM —

• DTC DETECTING CONDITION:

- Two consecutive driving cycles with fault

CAUTION:

After repair or replacement of faulty parts, conduct CLEAR MEMORY MODE <Ref. to 2-7 [T3D0].> and INSPECTION MODE <Ref. to 2-7 [T3E0].>

• WIRING DIAGRAM:

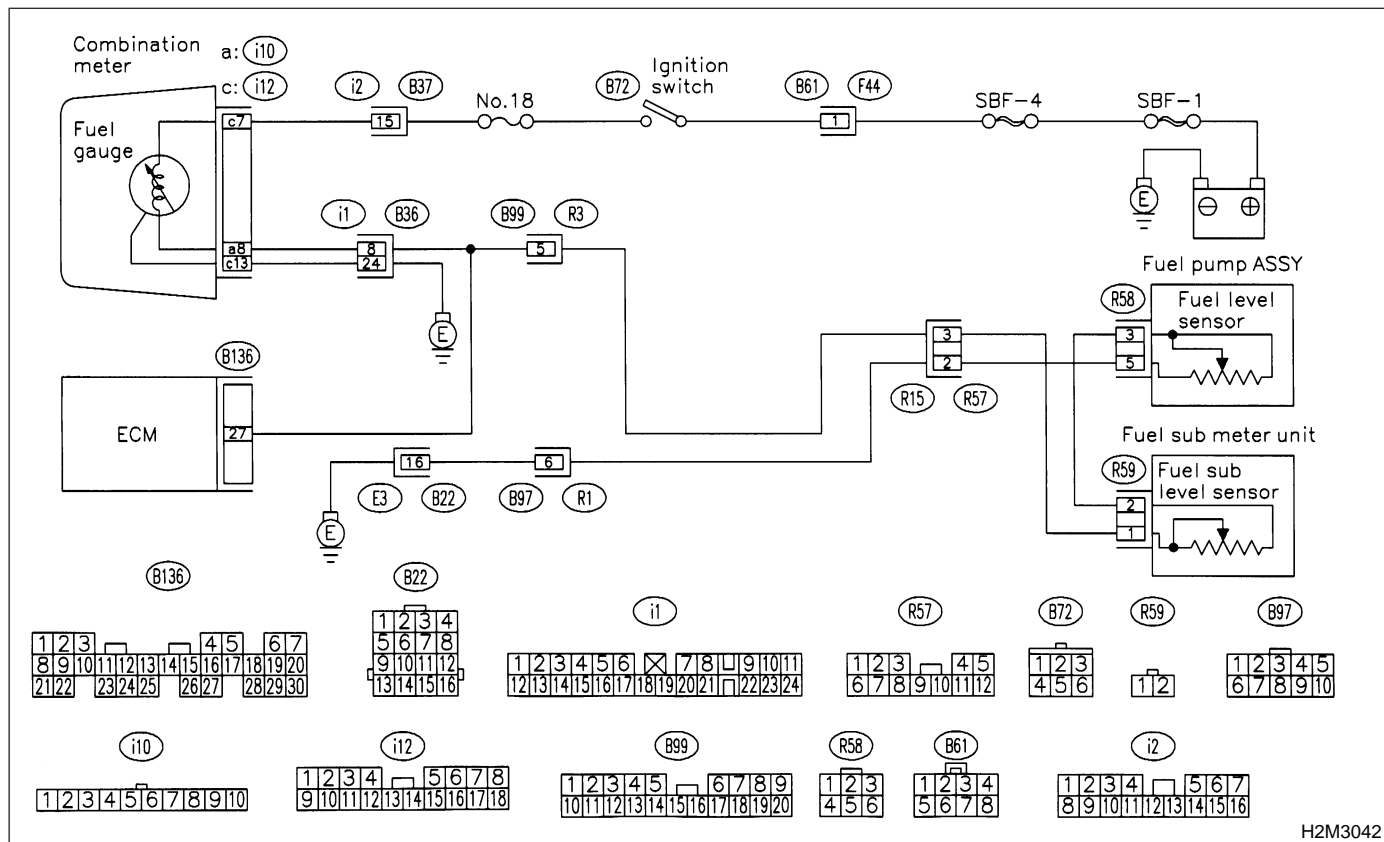

H2M3042

11AN1 : CHECK ANY OTHER DTC ON DISPLAY.

- CHECK** : Does the Subaru Select Monitor or OBD-II general scan tool indicate DTC P0462 or P0463?
- YES** : Inspect DTC P0462 or P0463 using "11. Diagnostics Chart with Trouble Code for Except 2200 cc California Spec. Vehicles". <Ref. to 2-7 [T11A0].>

NOTE:

In this case, it is not necessary to inspect this trouble.

- NO** : Replace fuel sending unit <Ref. to 2-1 [W8A0].> and fuel sub meter unit <Ref. to 2-1 [W10A0].>

AO: DTC P0462 — FUEL LEVEL SENSOR CIRCUIT LOW INPUT —

- **DTC DETECTING CONDITION:**
 - Two consecutive driving cycles with fault

CAUTION:

After repair or replacement of faulty parts, conduct **CLEAR MEMORY MODE** <Ref. to 2-7 [T3D0].> and **INSPECTION MODE** <Ref. to 2-7 [T3E0].>

● **WIRING DIAGRAM:**

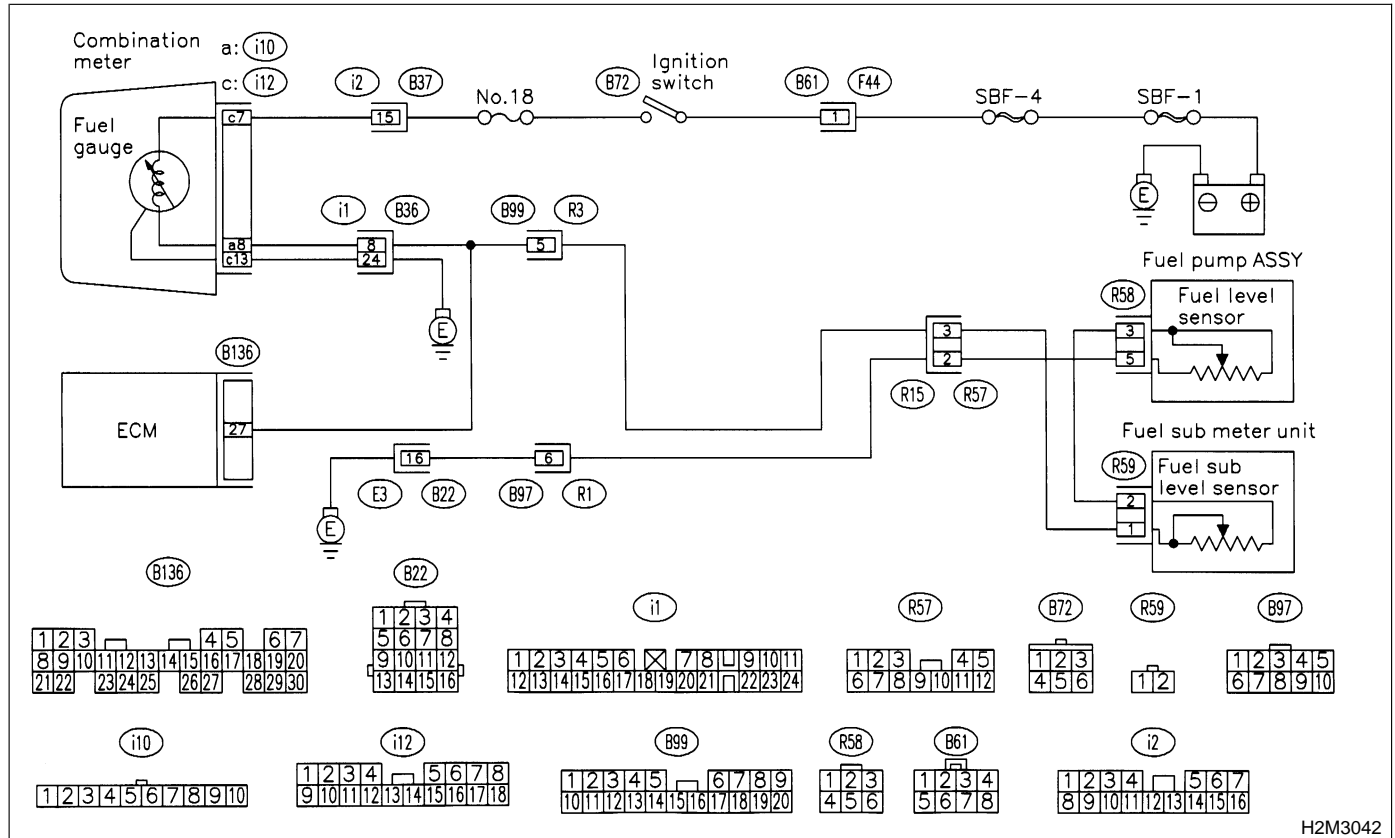

H2M3042

11A01 : CHECK SPEEDOMETER AND TACHOMETER OPERATION IN COMBINATION METER.

- CHECK** : Does speedometer and tachometer operate normally?
- YES** : Go to step 11A03.
- NO** : Go to step 11A02.

11A02 : CHECK GROUND CIRCUIT OF COMBINATION METER.

- 1) Turn ignition switch to OFF.
- 2) Pull out combination meter from instrument panel. <Ref. to 6-2 [W8A0].>

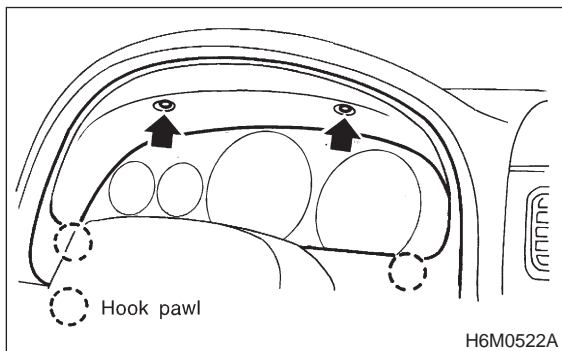

- 3) Disconnect connector from combination meter.
- 4) Measure resistance of harness between combination meter connector and chassis ground.

Connector & terminal
(i12) No. 13 — Chassis ground (-):

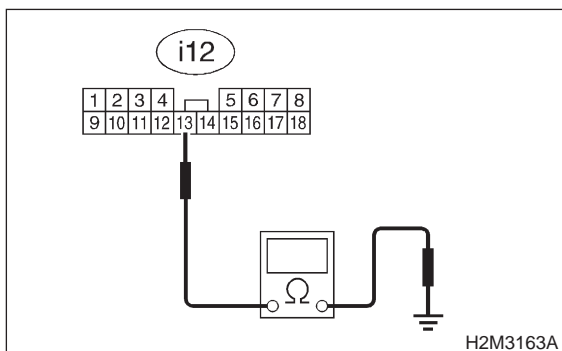

- CHECK** : Is resistance less than 5 Ω?
- YES** : Repair or replace combination meter. <Ref. to 6-2 [W8A0].>
- NO** : Repair harness and connector.

NOTE:

In this case, repair the following:

- Open circuit in harness between combination meter connector and grounding terminal
- Poor contact in combination meter connector
- Poor contact in grounding terminal

11A03 : CHECK INPUT SIGNAL FOR ECM.

- 1) Turn ignition switch to ON. (Engine OFF)
- 2) Measure voltage between ECM connector and chassis ground.

Connector & terminal
(B136) No. 27 (+) — Chassis ground (-):

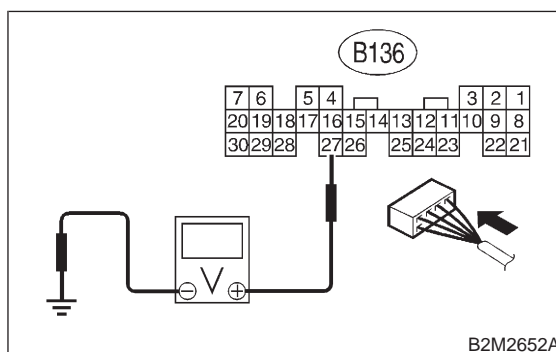

- CHECK** : Is the voltage less than 0.12 V?
- YES** : Go to step 11A05.
- NO** : Go to step 11A04.

11A04 : CHECK INPUT SIGNAL FOR ECM. (USING SUBARU SELECT MONITOR.)

Read data of fuel level sensor signal using Subaru Select Monitor.

NOTE:

- Subaru Select Monitor
- For detailed operation procedure, refer to the "READ CURRENT DATA SHOWN ON DISPLAY FOR ENGINE". <Ref. to 2-7 [T3C4].>

CHECK : Does the value change less than 0.12 V by shaking harness and connector of ECM while monitoring the value with Subaru Select Monitor?

- YES** : Repair poor contact in ECM connector.
- NO** : Even if MIL lights up, the circuit has returned to a normal condition at this time. A temporary poor contact of the connector may be the cause.

NOTE:

In this case, repair the following:

- Poor contact in fuel pump connector
- Poor contact in combination meter connector
- Poor contact in ECM connector
- Poor contact in coupling connectors (i1), (B22), (B99), (B97) and (R57)

11A05 : CHECK HARNESS BETWEEN ECM, COMBINATION METER AND FUEL PUMP CONNECTOR.

- 1) Turn ignition switch to OFF.
- 2) Remove fuel pump access hole lid located on the right rear of trunk compartment floor (Sedan) or luggage compartment floor (Wagon).

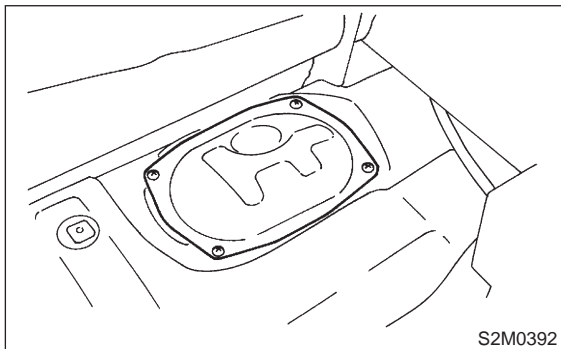

- 3) Disconnect connector from fuel pump.
- 4) Measure resistance of harness between fuel pump connector and chassis ground.

Connector & terminal

(R58) No. 3 — Chassis ground:

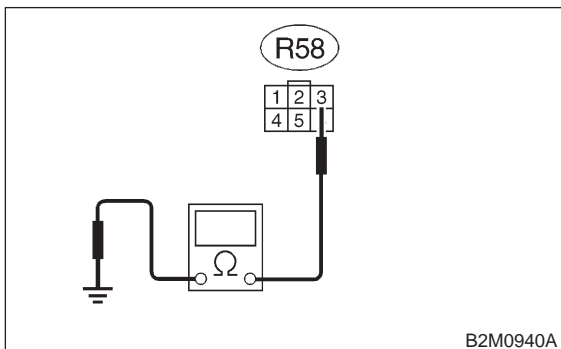

- CHECK** : Is the resistance less than 10 Ω?
- YES** : Go to step 11A06.
- NO** : Go to step 11A011.

11A06 : CHECK FUEL TANK CORD.

- 1) Remove service hole cover located on the left rear of trunk compartment floor (Sedan) or luggage compartment floor (Wagon).

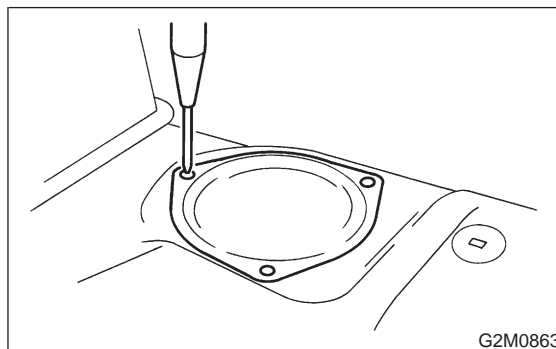

- 2) Disconnect connector from fuel sub meter unit.
- 3) Measure resistance of harness between fuel pump connector and chassis ground.

Connector & terminal

(R58) No. 3 — Chassis ground:

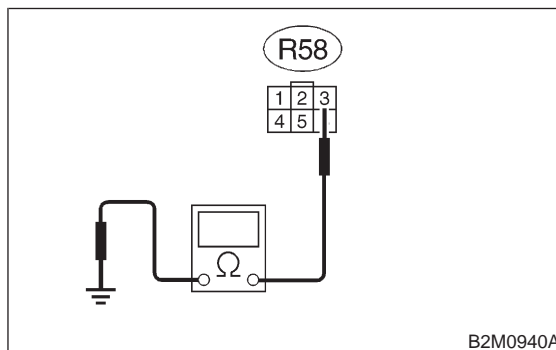

- CHECK** : Is the resistance less than 10 Ω?
- YES** : Repair ground short circuit in harness between fuel pump and fuel sub meter unit connector.
- NO** : Go to step 11A07.

2-7 [T11A07]

ON-BOARD DIAGNOSTICS II SYSTEM

11. Diagnostics Chart with Trouble Code for Except 2200 cc California Spec. Vehicles

11A07 : CHECK REAR WIRING HARNESS.

- 1) Separate fuel tank cord connector (R57) and rear wiring harness connector (R15).
- 2) Measure resistance of harness between fuel sub meter unit connector and chassis ground.

Connector & terminal

(R59) No. 1 — Chassis ground:

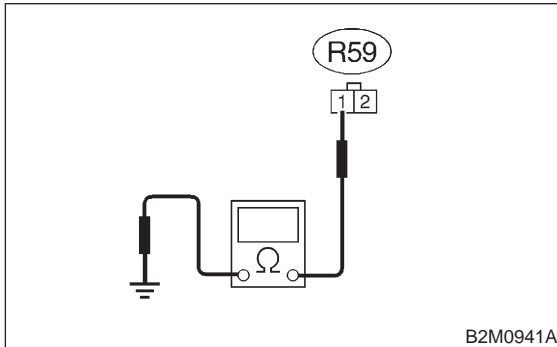

- CHECK** : Is the resistance less than 10 Ω?
- YES** : Repair ground short circuit in fuel tank cord.
- NO** : Go to step 11A08.

11A08 : CHECK REAR, BULKHEAD AND INSTRUMENT PANEL WIRING HARNESS.

- 1) Separate rear wiring harness connector (R3) and bulkhead wiring harness connector (B99).
- 2) Measure resistance of harness between rear wiring harness connector and chassis ground.

Connector & terminal

(R15) No. 3 — Chassis ground:

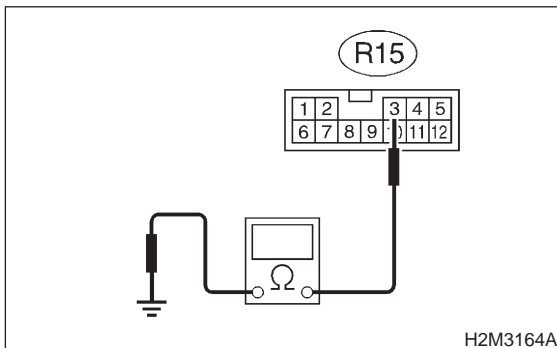

- CHECK** : Is the resistance less than 10 Ω?
- YES** : Go to step 11A09.
- NO** : Repair ground short circuit in bulkhead wiring harness.

11A09 : CHECK REAR WIRING HARNESS.

- 1) Separate rear wiring harness connector (R3) and bulkhead wiring harness connector (B99).
- 2) Measure resistance of harness between rear wiring harness connector and chassis ground.

Connector & terminal

(R3) No. 5 — Chassis ground:

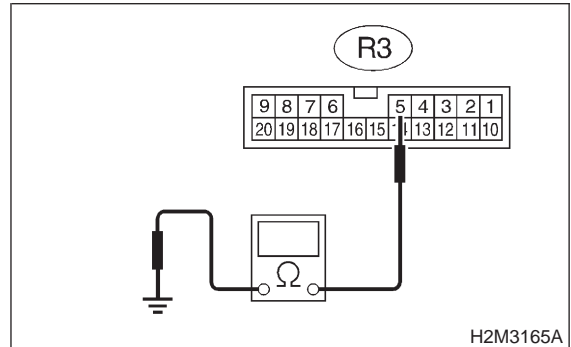

- CHECK** : Is the resistance less than 10 Ω?
- YES** : Repair ground short circuit in rear wiring harness.
- NO** : Go to step 11A010.

11A010 : CHECK BULKHEAD WIRING HARNESS.

- 1) Separate bulkhead wiring harness connector (B38) and instrument panel wiring harness connector (i3).
- 2) Measure resistance of harness between bulkhead wiring harness connector and chassis ground.

Connector & terminal

(B99) No. 5 — Chassis ground:

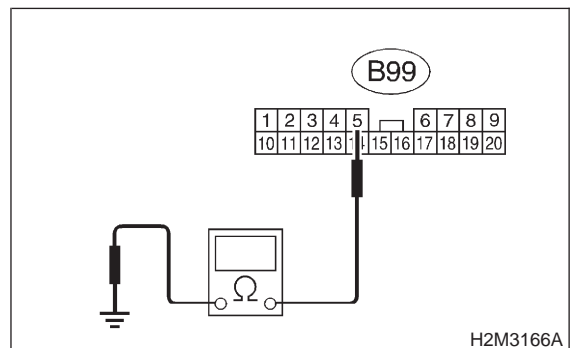

- CHECK** : Is the resistance less than 10 Ω?
- YES** : Repair ground short circuit in bulkhead wiring harness.
- NO** : Repair ground short circuit in instrument panel wiring harness.

11A011 : CHECK HARNESS BETWEEN COMBINATION METER AND FUEL PUMP CONNECTOR.

- 1) Connect connector to fuel pump.
- 2) Pull out combination meter from instrument panel. <Ref. to 6-2 [W8A0].>

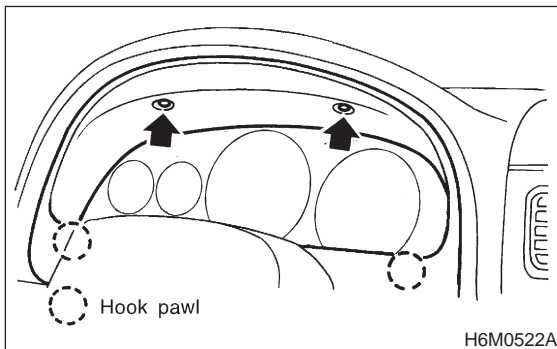

- 3) Disconnect connector from combination meter.
- 4) Measure resistance of harness between combination meter connector and chassis ground.

Connector & terminal

(i10) No. 8 — Chassis ground:

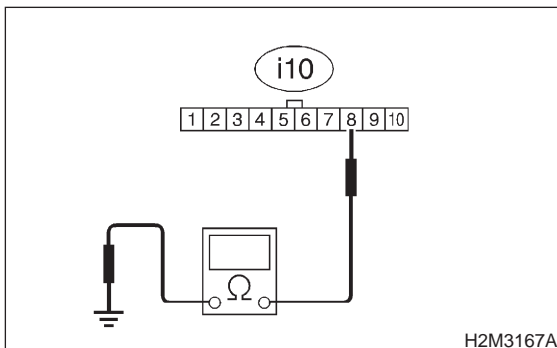

- CHECK** : *Is the resistance less than 200 Ω?*
- YES** : Go to step 11A012.
- NO** : Repair harness and connector.

NOTE:

In this case, repair the following:

- Open circuit in harness between combination meter connector and junction A on rear wiring harness
- Poor contact in coupling connectors (i1) and (B99)

11A012 : CHECK COMBINATION METER.

Disconnect connector from combination meter and remove combination meter.

- CHECK** : *Is the fuel meter installation screw tightened securely?*
- YES** : Go to step 11A013.
- NO** : Tighten fuel meter installation screw securely.

11A013 : CHECK COMBINATION METER PRINTED CIRCUIT PLATE.

Remove printed circuit plate assembly from combination meter assembly.

- CHECK** : *Is there flaw or burning on printed circuit plate assembly?*
- YES** : Replace printed circuit plate assembly.
- NO** : Replace fuel meter assembly. <Ref. to 6-2 [W8A0].>

2-7 [T11A013]

ON-BOARD DIAGNOSTICS II SYSTEM

11. Diagnostics Chart with Trouble Code for Except 2200 cc California Spec. Vehicles

MEMO:

AP: DTC P0463 — FUEL LEVEL SENSOR CIRCUIT HIGH INPUT —

- **DTC DETECTING CONDITION:**
 - Two consecutive driving cycles with fault

CAUTION:

After repair or replacement of faulty parts, conduct **CLEAR MEMORY MODE** <Ref. to 2-7 [T3D0].> and **INSPECTION MODE** <Ref. to 2-7 [T3E0].>

● **WIRING DIAGRAM:**

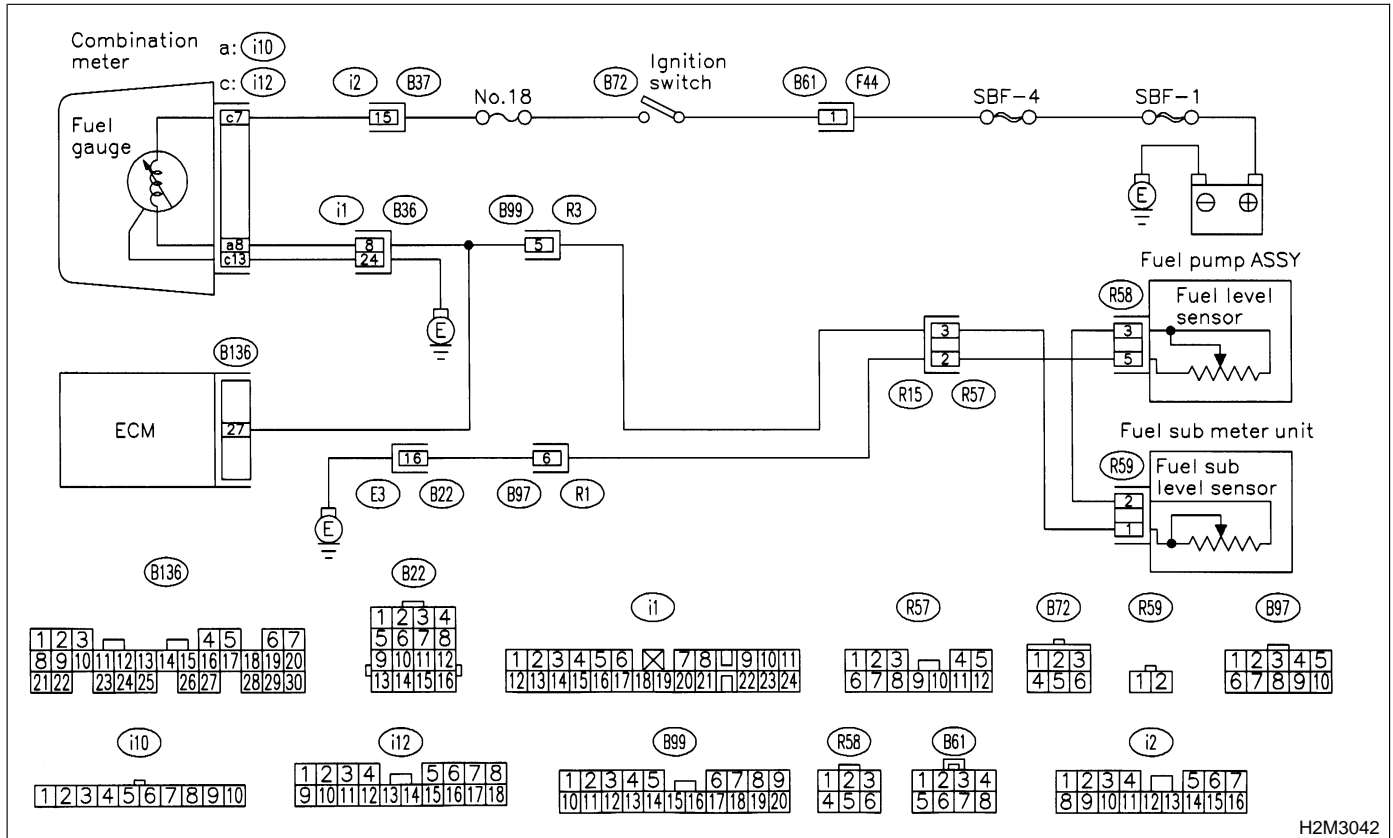

H2M3042

11AP1 : CHECK SPEEDOMETER AND TACHOMETER OPERATION IN COMBINATION METER.

- CHECK** : Does speedometer and tachometer operate normally?
- YES** : Go to step 11AP3.
- NO** : Go to step 11AP2.

2-7 [T11AP2]

ON-BOARD DIAGNOSTICS II SYSTEM

11. Diagnostics Chart with Trouble Code for Except 2200 cc California Spec. Vehicles

11AP2 : CHECK GROUND CIRCUIT OF COMBINATION METER.

- 1) Turn ignition switch to OFF.
- 2) Pull out combination meter from instrument panel. <Ref. to 6-2 [W8A0].>

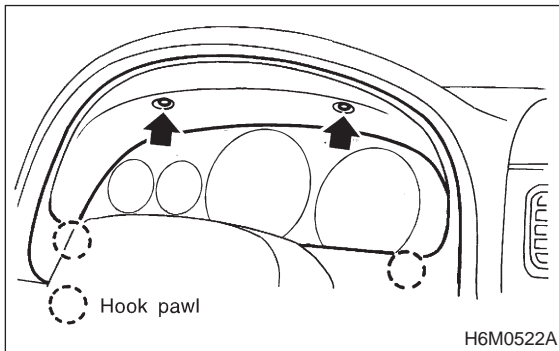

- 3) Disconnect connector from combination meter.
- 4) Measure resistance of harness between combination meter connector and chassis ground.

Connector & terminal

(i12) No. 13 — Chassis ground:

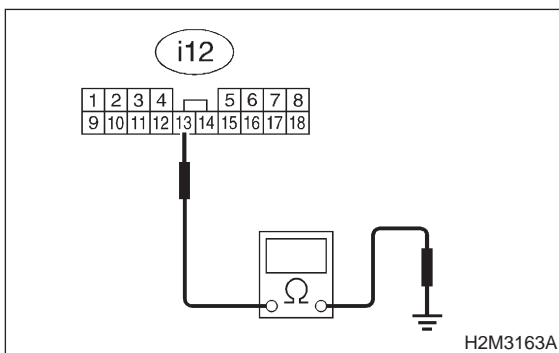

CHECK : Is resistance less than 5 Ω?

YES : Repair or replace combination meter. <Ref. to 6-2 [W8A0].>

NO : Repair harness and connector.

NOTE:

In this case, repair the following:

- Open circuit in harness between combination meter connector and grounding terminal
- Poor contact in combination meter connector
- Poor contact in grounding terminal

11AP3 : CHECK INPUT SIGNAL FOR ECM.

- 1) Turn ignition switch to ON. (Engine OFF)
- 2) Measure voltage between ECM connector and chassis ground.

Connector & terminal

(B136) No. 27 (+) — Chassis ground (-):

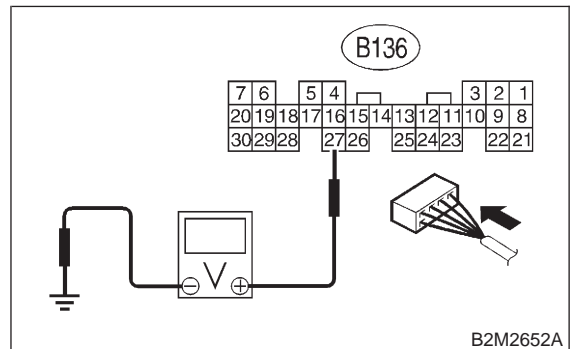

CHECK : Is the voltage more than 4.75 V?

YES : Go to step 11AP4.

NO : Even if MIL lights up, the circuit has returned to a normal condition at this time. A temporary poor contact of the connector may be the cause.

NOTE:

In this case, repair the following:

- Poor contact in fuel pump connector
- Poor contact in combination meter connector
- Poor contact in ECM connector
- Poor contact in coupling connector (i1), (B99), (B22), (B97) and (R57)

11AP4 : CHECK FUEL LEVEL SENSOR.

- 1) Turn ignition switch to OFF.
- 2) Remove fuel pump access hole lid located on the right rear of trunk compartment floor (Sedan) or luggage compartment floor (Wagon).

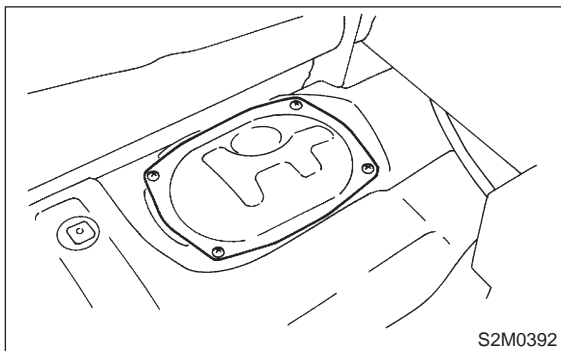

- 3) Disconnect connector from fuel pump.
- 4) Measure resistance between connector terminals of fuel pump.

Terminals

No. 3 — No. 5:

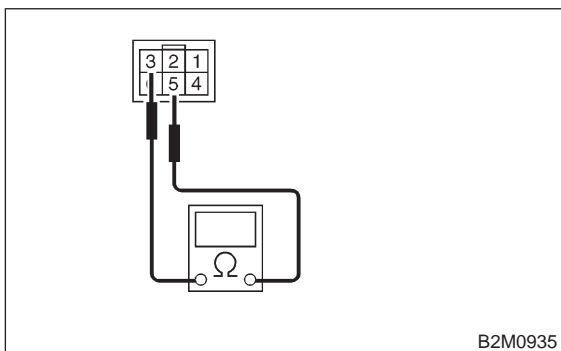

- CHECK** : Is the resistance less than 100 Ω?
- YES** : Go to step 11AP5.
- NO** : Replace fuel sending unit. <Ref. to 2-1 [W8A0].>

11AP5 : CHECK FUEL SUB LEVEL SENSOR.

- 1) Remove service hole cover located on the left rear of trunk compartment floor (Sedan) or luggage compartment floor (Wagon).

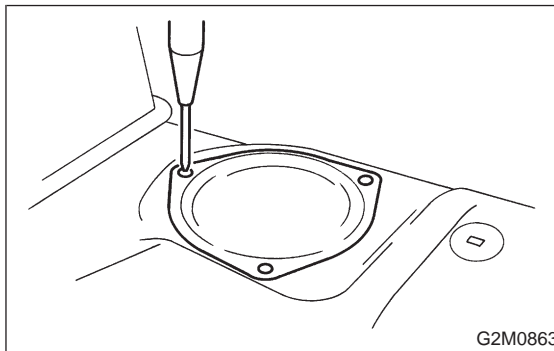

- 2) Disconnect connector from fuel sub meter unit.
- 3) Measure resistance between connector terminals of fuel sub meter unit.

Terminals

No. 1 — No. 2:

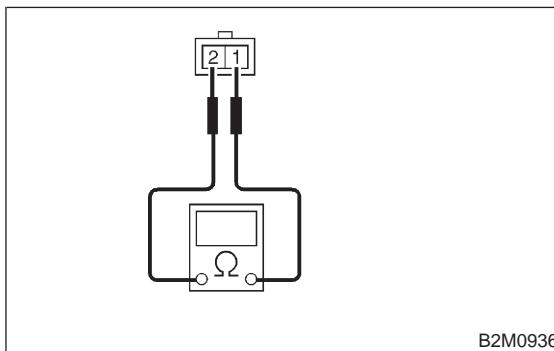

- CHECK** : Is the resistance less than 100 Ω?
- YES** : Go to step 11AP6.
- NO** : Replace fuel sub meter unit. <Ref. to 2-1 [W10A0].>

2-7 [T11AP6]

ON-BOARD DIAGNOSTICS II SYSTEM

11. Diagnostics Chart with Trouble Code for Except 2200 cc California Spec. Vehicles

11AP6 : CHECK HARNESS BETWEEN FUEL PUMP AND FUEL SUB METER UNIT CONNECTOR.

Measure resistance of harness between fuel pump and fuel sub meter unit connector.

Connector & terminal

(R58) No. 3 — (R59) No. 2:

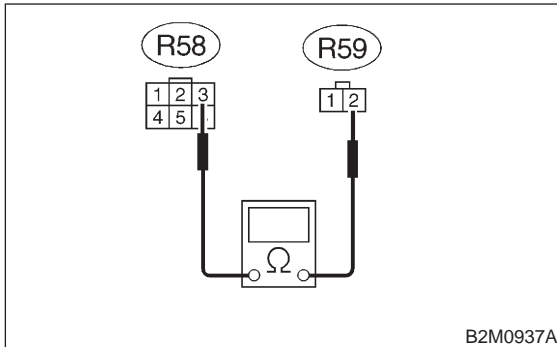

- CHECK** : Is the resistance less than 1 Ω?
YES : Go to step 11AP7.
NO : Repair open circuit in harness between fuel pump and fuel sub meter unit connector.

11AP7 : CHECK GROUND CIRCUIT OF FUEL LEVEL SENSOR.

Measure resistance of harness between fuel pump connector and chassis ground.

Connector & terminal

(R58) No. 5 — Chassis ground:

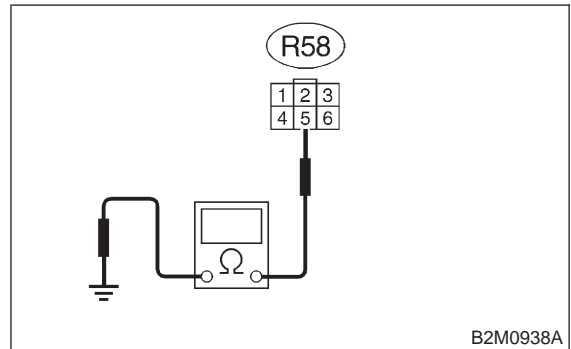

- CHECK** : Is the resistance less than 5 Ω?
YES : Go to step 11AP8.
NO : Repair harness and connector.

NOTE:

In this case, repair the following:

- Open circuit in harness between fuel pump connector and chassis grounding terminal
- Poor contact in fuel pump connector
- Poor contact in coupling connectors (R57), (B97) and (B22)

11AP8 : CHECK HARNESS BETWEEN ECM AND FUEL PUMP CONNECTOR.

- 1) Connect connector to fuel sub meter unit.
- 2) Turn ignition switch to ON.
- 3) Measure voltage between fuel pump connector and chassis ground.

Connector & terminal

(R58) No. 3 (+) — Chassis ground (-):

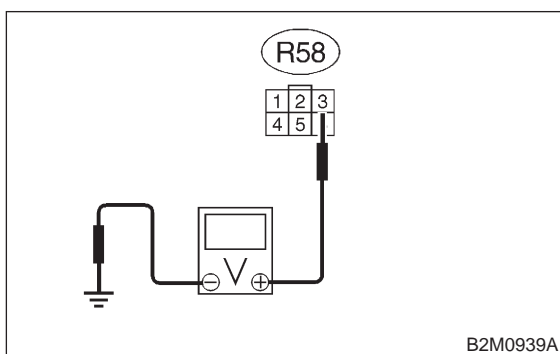

CHECK : *Is the voltage less than 1 V?*

YES : Repair harness and connector.

NOTE:

In this case, repair the following:

- Open circuit in harness between fuel pump connector and junction A on rear wiring harness
- Poor contact in fuel sub meter unit connector
- Poor contact in fuel pump connector
- Poor contact in coupling connector (R57)

NO : Go to step **11AP9**.

11AP9 : CHECK HARNESS BETWEEN ECM AND FUEL PUMP CONNECTOR.

- 1) Turn ignition switch to OFF.
- 2) Disconnect connector from ECM.
- 3) Turn ignition switch to ON.
- 4) Measure voltage between ECM connector and chassis ground.

Connector & terminal

(B136) No. 27 (+) — Chassis ground (-):

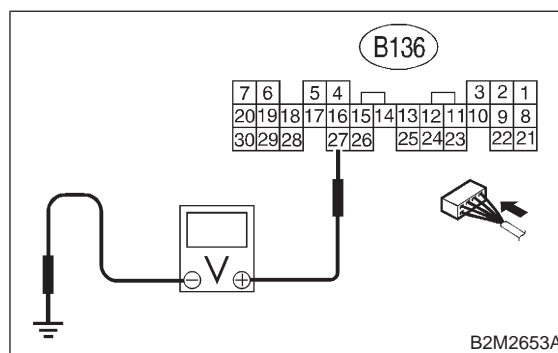

CHECK : *Is the voltage less than 1 V?*

YES : Repair harness and connector.

NOTE:

In this case, repair the following:

- Open circuit in harness between ECM connector and junction A on rear wiring harness
- Poor contact in coupling connector (B97)

NO : Repair connector.

NOTE:

In this case, repair the following:

- Poor contact in fuel pump connector
- Poor contact in fuel sub meter unit
- Poor contact in ECM connector

2-7 [T11AP9]

ON-BOARD DIAGNOSTICS II SYSTEM

11. Diagnostics Chart with Trouble Code for Except 2200 cc California Spec. Vehicles

MEMO:

AQ: DTC P0480 — COOLING FAN RELAY 1 CIRCUIT LOW INPUT —

- **DTC DETECTING CONDITION:**
 - Two consecutive driving cycles with fault
- **TROUBLE SYMPTOM:**
 - Radiator fan does not operate properly.
 - Overheating

CAUTION:

After repair or replacement of faulty parts, conduct **CLEAR MEMORY MODE** <Ref. to 2-7 [T3D0].> and **INSPECTION MODE** <Ref. to 2-7 [T3E0].>

● **WIRING DIAGRAM:**

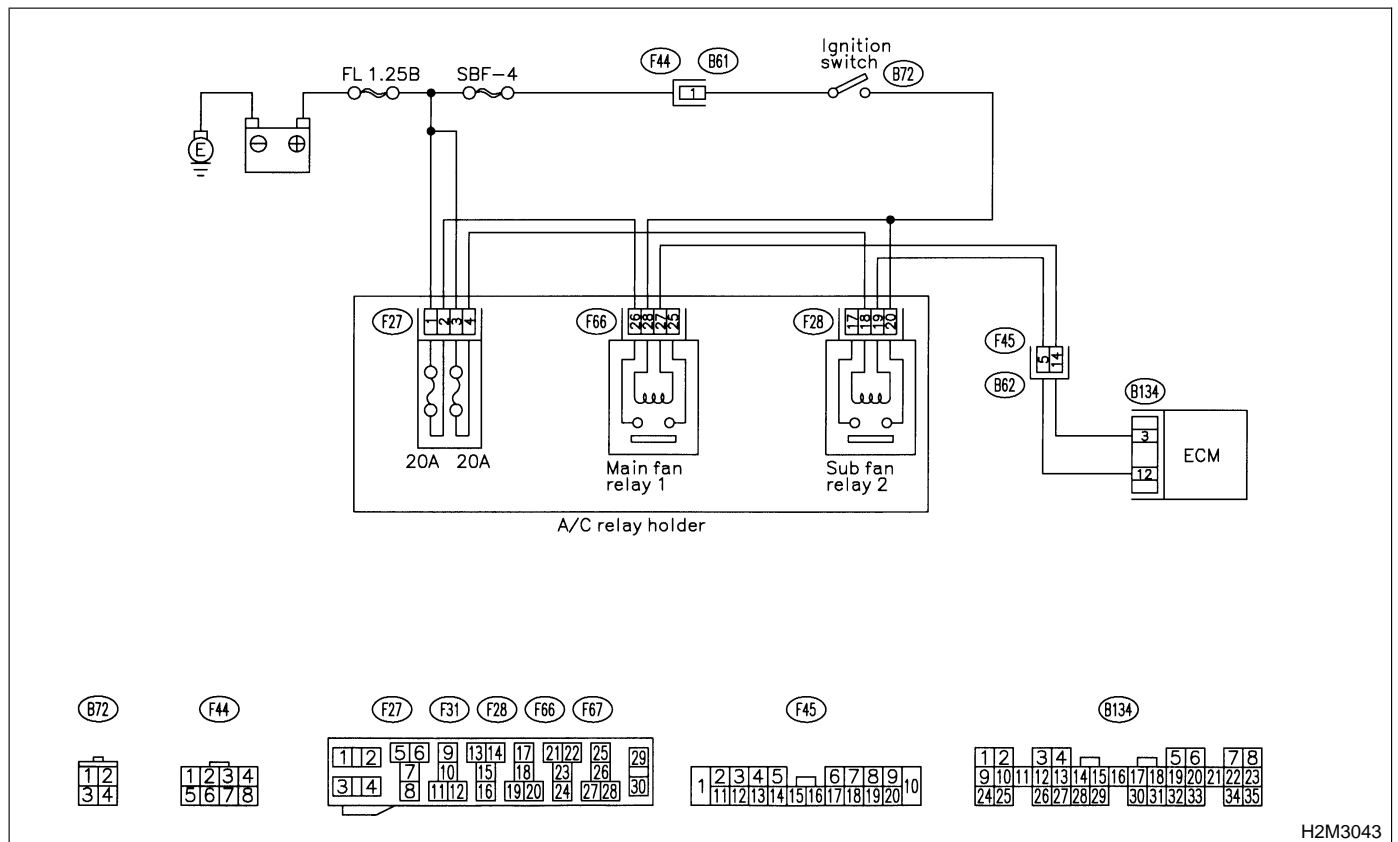

H2M3043

2-7 [T11AQ1]

ON-BOARD DIAGNOSTICS II SYSTEM

11. Diagnostics Chart with Trouble Code for Except 2200 cc California Spec. Vehicles

11AQ1 : CHECK OUTPUT SIGNAL FROM ECM.

- 1) Turn ignition switch to OFF.
- 2) Connect test mode connector at the lower portion of instrument panel (on the driver's side), to the side of the center console box.

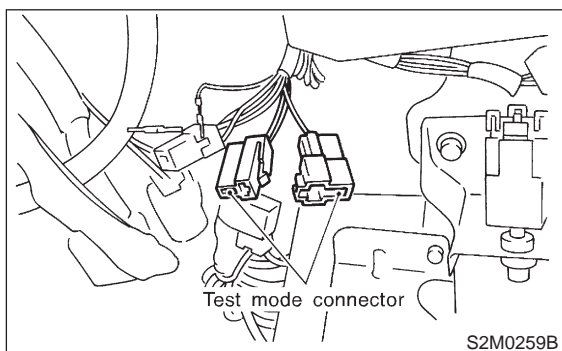

- 3) Turn ignition switch to ON.
- 4) Measure voltage between ECM and chassis ground.

NOTE:

Radiator fan relay operation check can be executed using Subaru Select Monitor. For procedure, refer to "COMPULSORY VALVE OPERATION CHECK MODE". <Ref. to 2-7 [T3F0].>

Connector & terminal

(B134) No. 3 (+) — Chassis ground (-):

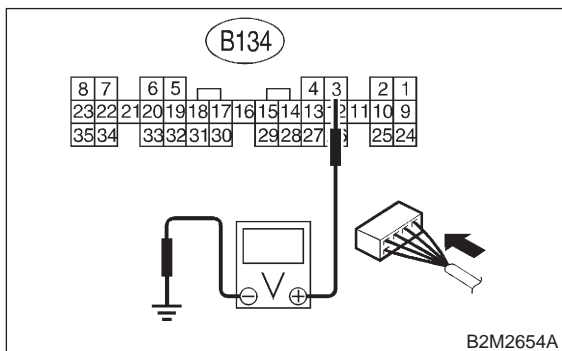

- CHECK** : Does voltage change between 0 and 10 volts?
- YES** : Repair poor contact in ECM connector.
- NO** : Go to step 11AQ2.

11AQ2 : CHECK GROUND SHORT CIRCUIT IN RADIATOR FAN RELAY 1 CONTROL CIRCUIT.

- 1) Turn ignition switch to OFF.
- 2) Disconnect connectors from ECM.
- 3) Measure resistance of harness between ECM connector and chassis ground.

Connector & terminal

(B134) No. 3 — Chassis ground:

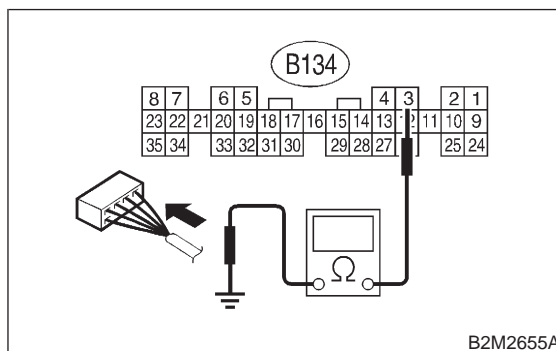

- CHECK** : Is the resistance less than 10 Ω?
- YES** : Repair ground short circuit in radiator fan relay 1 control circuit.
- NO** : Go to step 11AQ3.

11AQ3 : CHECK POWER SUPPLY FOR RELAY.

- 1) Remove main fan relay from A/C relay holder.
- 2) Turn ignition switch to ON.
- 3) Measure voltage between fuse and relay box (F/B) connector and chassis ground.

Connector & terminal

(F66) No. 28 (+) — Chassis ground (-):

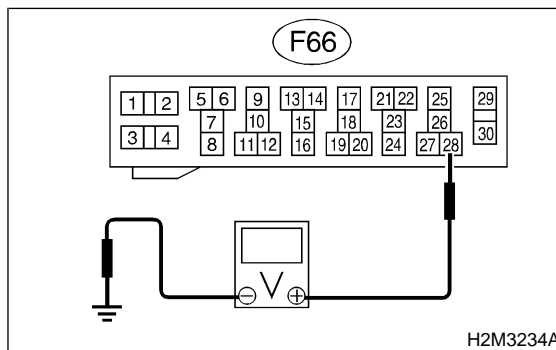

- CHECK** : Is the voltage more than 10 V?
- YES** : Go to step 11AQ4.
- NO** : Repair open circuit in harness between ignition switch and fuse and relay box (F/B) connector.

11AQ4 : CHECK MAIN FAN RELAY 1.

- 1) Turn ignition switch to OFF.
- 2) Measure resistance between main fan relay 1 terminals.

Terminal

No. 27 — No. 28:

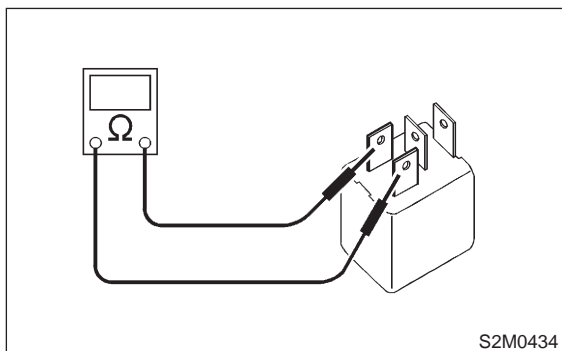

- CHECK** : *Is the resistance between 87 and 107 Ω ?*
- YES** : Go to step 11AQ5.
- NO** : Replace main fan relay 1.

11AQ5 : CHECK OPEN CIRCUIT IN MAIN FAN RELAY CONTROL CIRCUIT.

Measure resistance of harness between ECM and main fan relay connector.

Connector & terminal

(B134) No. 3 — (F66) No. 27:

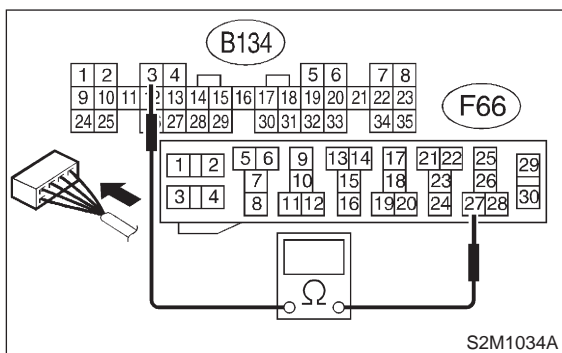

- CHECK** : *Is the resistance less than 1 Ω ?*
- YES** : Go to step 11AQ6.
- NO** : Repair harness and connector.

NOTE:

In this case, repair the following:

- Open circuit in harness between ECM and main fan relay 1 connector
- Poor contact in coupling connector (F45)

11AQ6 : CHECK POOR CONTACT.

Check poor contact in ECM or main fan relay 1 connector. <Ref. to FOREWORD [T3C1].>

- CHECK** : *Is there poor contact in ECM or main fan relay 1 connector?*
- YES** : Repair poor contact in ECM or main fan relay 1 connector.
- NO** : Contact with SOA service.

2-7 [T11AQ6]

ON-BOARD DIAGNOSTICS II SYSTEM

11. Diagnostics Chart with Trouble Code for Except 2200 cc California Spec. Vehicles

MEMO:

AR: DTC P0483 — COOLING FAN FUNCTION PROBLEM —

- **DTC DETECTING CONDITION:**
 - Two consecutive driving cycles with fault
- **TROUBLE SYMPTOM:**
 - Occurrence of noise
 - Overheating

CAUTION:

After repair or replacement of faulty parts, conduct **CLEAR MEMORY MODE** <Ref. to 2-7 [T3D0].> and **INSPECTION MODE** <Ref. to 2-7 [T3E0].>

NOTE:

If the vehicle, with the engine idling, is placed very close to a wall or another vehicle, preventing normal cooling function, the OBD system may detect malfunction.

● **WIRING DIAGRAM:**

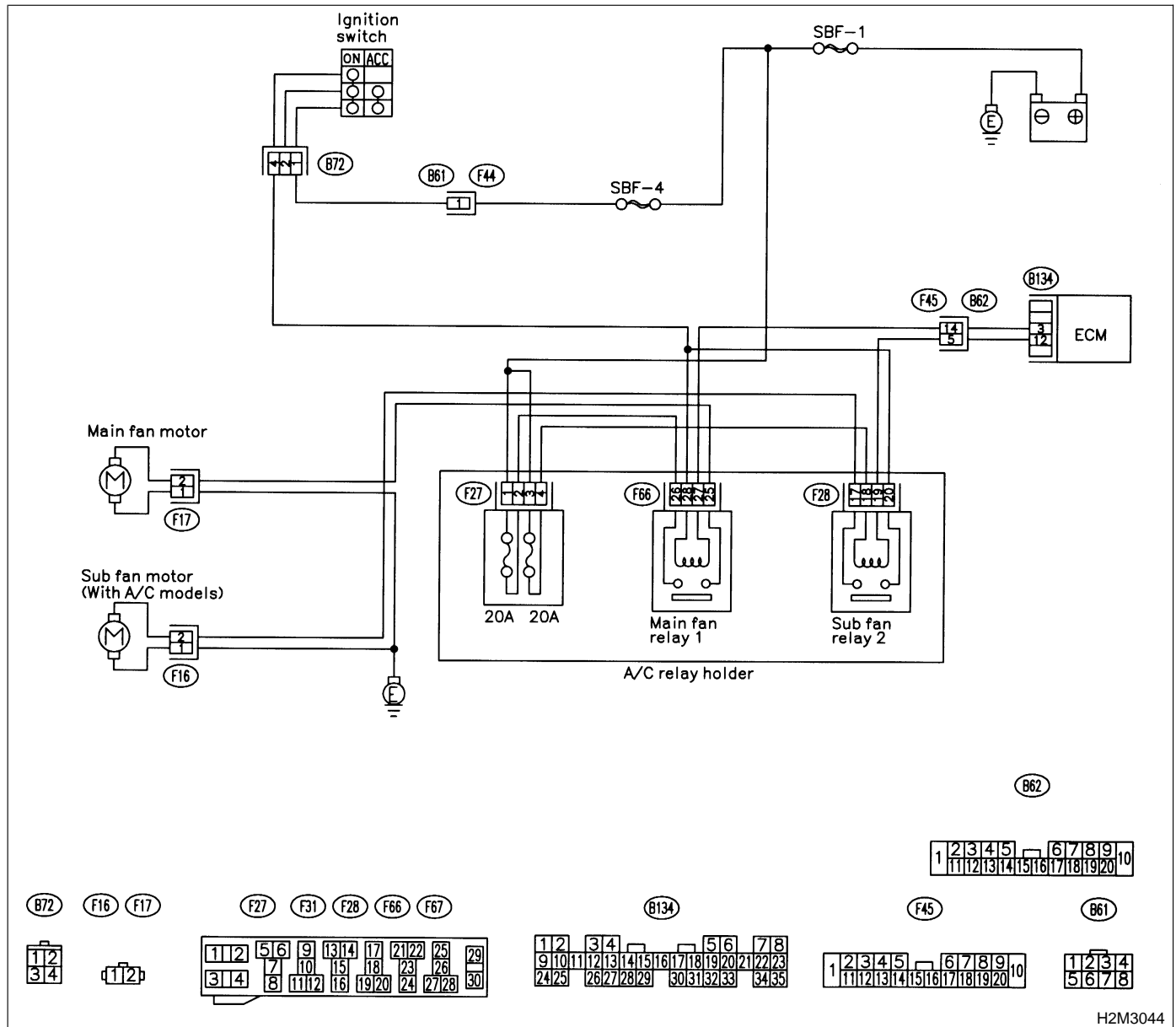

2-7 [T11AR1]

ON-BOARD DIAGNOSTICS II SYSTEM

11. Diagnostics Chart with Trouble Code for Except 2200 cc California Spec. Vehicles

11AR1 : CHECK ANY OTHER DTC ON DISPLAY.

- CHECK** : *Is there any other DTC on display?*
- YES** : Inspect the relevant DTC using "11. Diagnostics Chart with Trouble Code for Except 2200 cc California Spec. Vehicles". <Ref. to 2-7 [T11A0].>
- NO** : Check engine cooling system. <Ref. to 2-5 [T100].>

AS: DTC P0500 — VEHICLE SPEED SENSOR MALFUNCTION —

- **DTC DETECTING CONDITION:**
 - Immediately at fault recognition

CAUTION:

After repair or replacement of faulty parts, conduct **CLEAR MEMORY MODE** <Ref. to 2-7 [T3D0].> and **INSPECTION MODE** <Ref. to 2-7 [T3E0].>

● **WIRING DIAGRAM:**

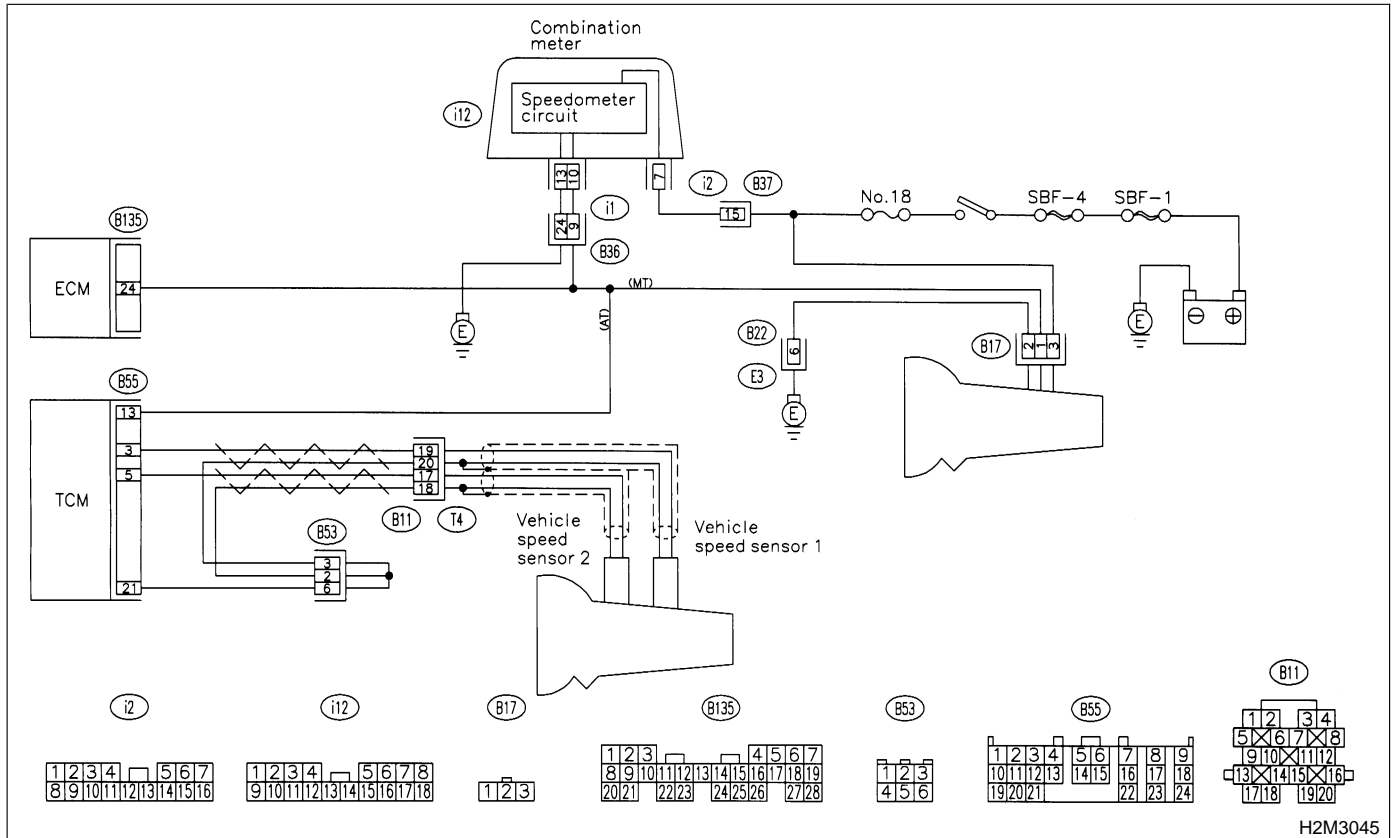

H2M3045

11AS1 : CHECK TRANSMISSION TYPE.

- CHECK** : *Is transmission type AT?*
- YES** : Go to step 11AS2.
- NO** : Go to step 11AS3.

11AS2 : CHECK DTC P0720 ON DISPLAY.

- CHECK** : *Does the Subaru Select Monitor or OBD-II general scan tool indicate DTC P0720?*
- YES** : Check vehicle speed sensor 2 signal circuit. <Ref. to 3-2 [T8G0].>
- NO** : Go to step 11AS3.

11AS3 : CHECK SPEEDOMETER OPERATION IN COMBINATION METER.

- CHECK** : *Does speedometer operate normally?*
- YES** : Go to step 11AS4.
- NO** : Check speedometer and vehicle speed sensor. <Ref. to 6-2 [K2A4].>

2-7 [T11AS4]

ON-BOARD DIAGNOSTICS II SYSTEM

11. Diagnostics Chart with Trouble Code for Except 2200 cc California Spec. Vehicles

11AS4 : CHECK HARNESS BETWEEN ECM AND COMBINATION METER CONNECTOR.

- 1) Turn ignition switch to OFF.
- 2) Disconnect connector from TCM.
- 3) Turn ignition switch to ON.
- 4) Measure voltage between ECM and chassis ground.

Connector & terminal

(B135) No. 24 (+) — Chassis ground (-):

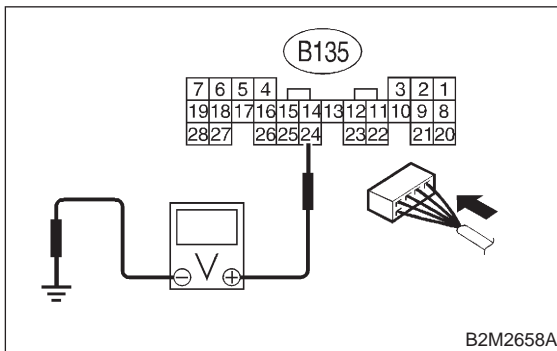

- CHECK** : *Is the voltage more than 2 V?*
YES : Repair harness and connector.

NOTE:

In this case, repair the following:

- Open circuit in harness between ECM and combination meter connector
- Poor contact in ECM connector
- Poor contact in combination meter connector
- Poor contact in coupling connector (B36)

- NO** : Go to step **11AS5**.

11AS5 : CHECK HARNESS BETWEEN ECM AND COMBINATION METER CONNECTOR.

- 1) Turn ignition switch to OFF.
- 2) Disconnect connector from ECM.
- 3) Measure resistance of harness between ECM connector and chassis ground.

Connector & terminal

(B135) No. 24 — Chassis ground:

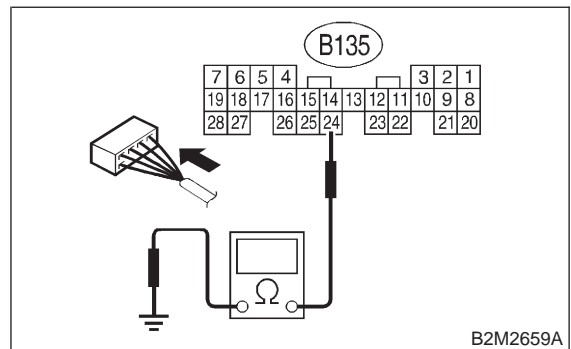

- CHECK** : *Is the resistance less than 10 Ω?*
YES : Repair ground short circuit in harness between ECM and combination meter connector.
NO : Repair poor contact in ECM connector.

AT: DTC P0506 — IDLE CONTROL SYSTEM RPM LOWER THAN EXPECTED

- **DTC DETECTING CONDITION:**
 - Two consecutive driving cycles with fault
- **TROUBLE SYMPTOM:**
 - Engine is difficult to start.
 - Engine does not start.
 - Erroneous idling
 - Engine stalls.

CAUTION:

After repair or replacement of faulty parts, conduct CLEAR MEMORY MODE <Ref. to 2-7 [T3D0].> and INSPECTION MODE <Ref. to 2-7 [T3E0].>

● **WIRING DIAGRAM:**

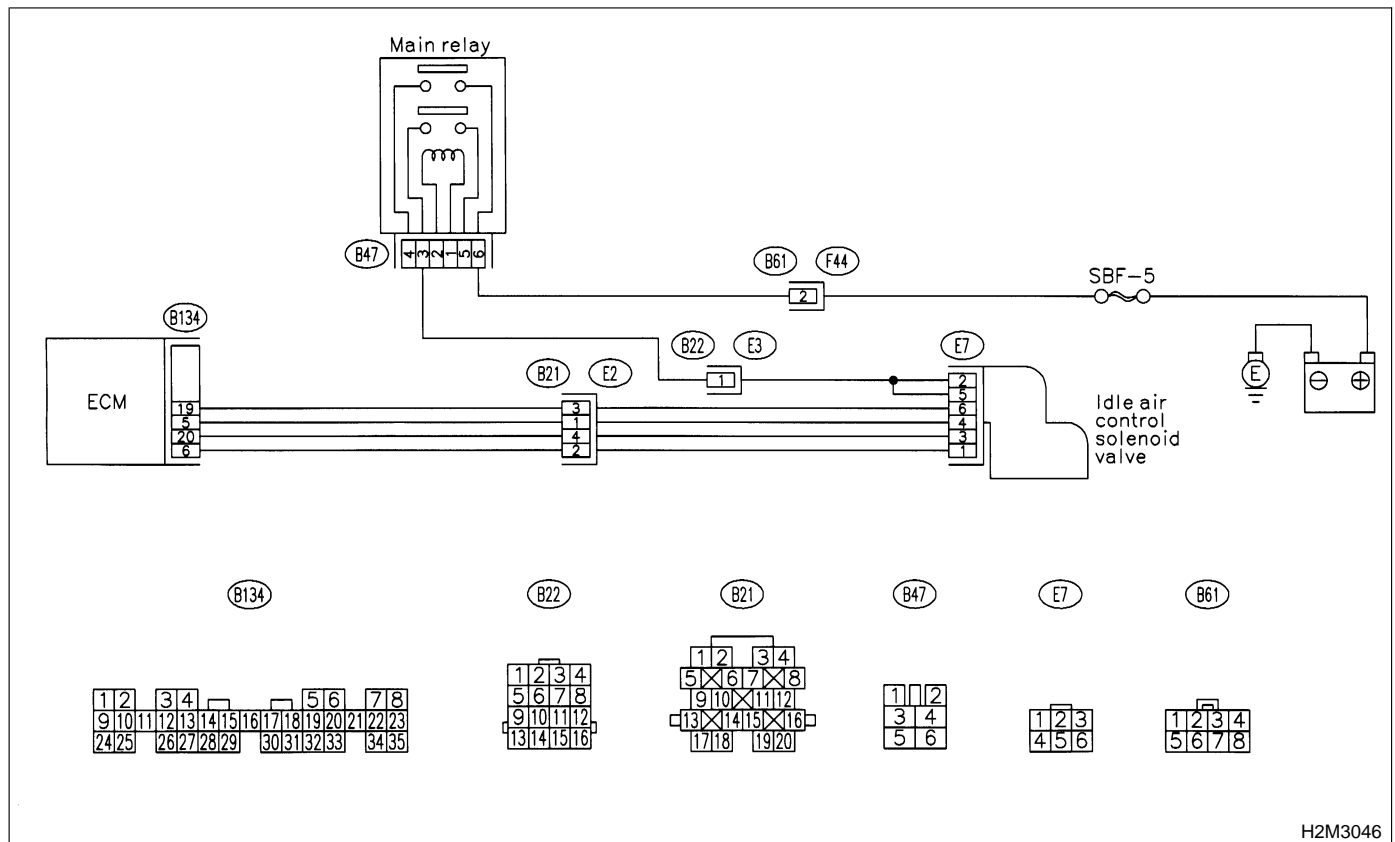

H2M3046

11AT1 : CHECK ANY OTHER DTC ON DISPLAY.

CHECK : *Does the Subaru Select Monitor or OBD-II general scan tool indicate DTC P1510, P1511, P1512, P1513, P1514, P1515, P1516 or P1517?*

YES : Inspect DTC P1510, P1511, P1512, P1513, P1514, P1515, P1516 or P1517 using "11. Diagnostics Chart with Trouble Code for Except 2200 cc California Spec. Vehicles". <Ref. to 2-7 [T11A0].>

NOTE:

In this case, it is not necessary to inspect DTC P0506.

NO : Go to step 11AT2.

11AT2 : CHECK AIR BY-PASS LINE.

- 1) Turn ignition switch to OFF.
- 2) Remove idle air control solenoid valve from throttle body. <Ref. to 2-7 [W12A2].>
- 3) Remove throttle body from intake manifold. <Ref. to 2-7 [W3A2].>
- 4) Confirm that there is no foreign matter stuck in the air by-pass line.
- 5) Using an air gun, force air into idle air control solenoid valve installation area. Confirm that forced air subsequently escapes from throttle body interior.

CHECK : *Does air flow out?*

YES : Replace idle air control solenoid valve. <Ref. to 2-7 [W12A2].>

NO : Replace throttle body. <Ref. to 2-7 [W3A2].>

AU: DTC P0507 — IDLE CONTROL SYSTEM RPM HIGHER THAN EXPECTED

● **DTC DETECTING CONDITION:**

- Two consecutive driving cycles with fault

● **TROUBLE SYMPTOM:**

- Engine keeps running at higher revolution than specified idling revolution.

CAUTION:

After repair or replacement of faulty parts, conduct **CLEAR MEMORY MODE** <Ref. to 2-7 [T3D0].> and **INSPECTION MODE** <Ref. to 2-7 [T3E0].>

● **WIRING DIAGRAM:**

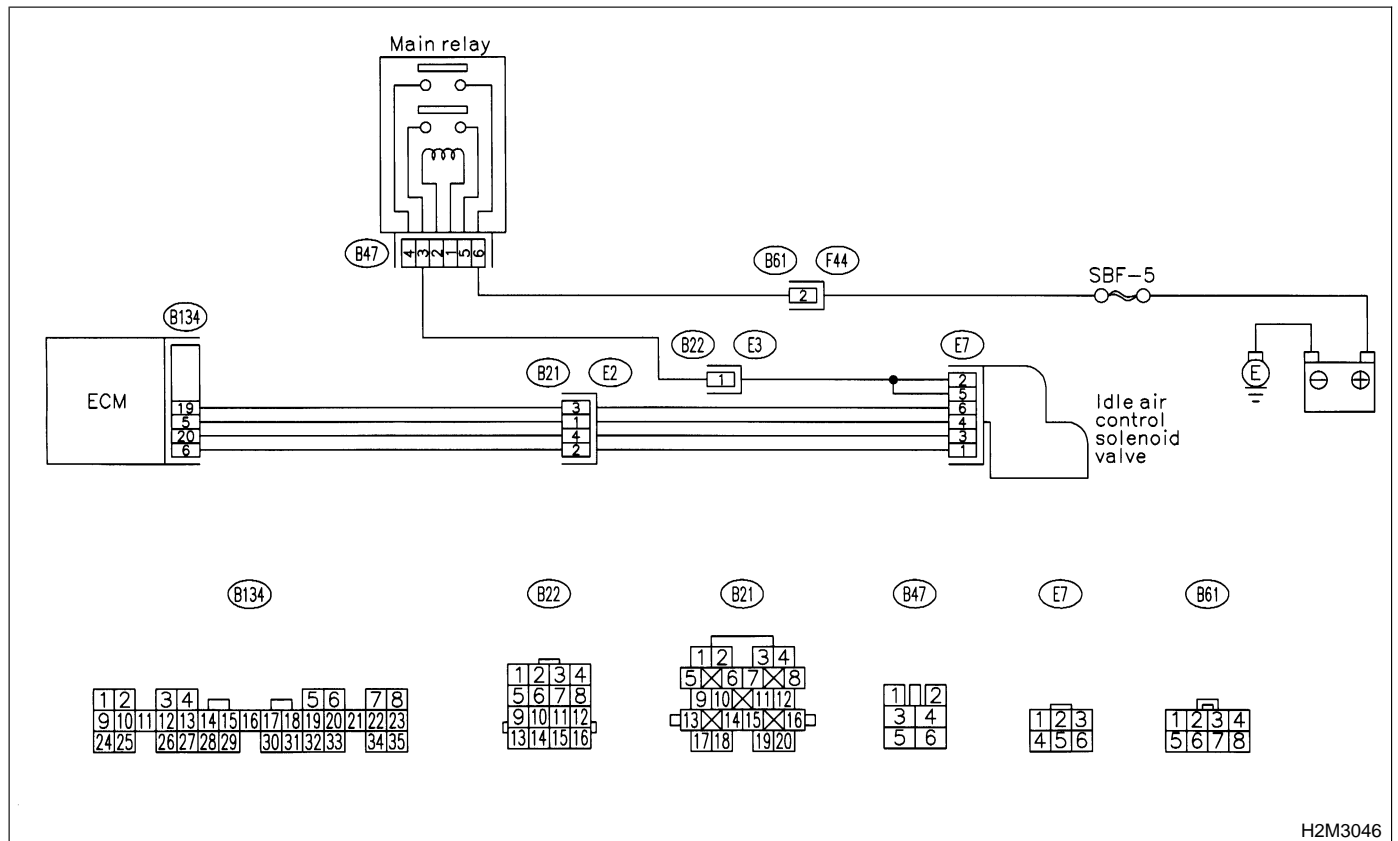

H2M3046

2-7 [T11AU1]

ON-BOARD DIAGNOSTICS II SYSTEM

11. Diagnostics Chart with Trouble Code for Except 2200 cc California Spec. Vehicles

11AU1 : CHECK ANY OTHER DTC ON DISPLAY.

CHECK : ***Does the Subaru Select Monitor or OBD-II general scan tool indicate DTC P1510, P1511, P1512, P1513, P1514, P1515, P1516 or P1517?***

YES : Inspect DTC P1510, P1511, P1512, P1513, P1514, P1515, P1516 or P1517 using "11. Diagnostics Chart with Trouble Code for Except 2200 cc California Spec. Vehicles". <Ref. to 2-7 [T11A0].>

NOTE:

In this case, it is not necessary to inspect DTC P0507.

NO : Go to step **11AU2**.

11AU2 : CHECK AIR INTAKE SYSTEM.

- 1) Turn ignition switch to ON.
- 2) Start engine, and idle it.
- 3) Check the following items.
 - Loose installation of intake manifold, idle air control solenoid valve and throttle body
 - Cracks of intake manifold gasket, idle air control solenoid valve gasket and throttle body gasket
 - Disconnections of vacuum hoses

CHECK : ***Is there a fault in air intake system?***

YES : Repair air suction and leaks.

NO : Go to step **11AU3**.

11AU3 : CHECK AIR BY-PASS LINE.

- 1) Turn ignition switch to OFF.
- 2) Remove idle air control solenoid valve from throttle body. <Ref. to 2-7 [W12A2].>
- 3) Confirm that there are no foreign particles in by-pass air line.

CHECK : ***Are foreign particles in by-pass air line?***

YES : Remove foreign particles from by-pass air line.

NO : Replace idle air control solenoid valve. <Ref. to 2-7 [W12A2].>

AV: DTC P0601 — INTERNAL CONTROL MODULE MEMORY CHECK SUM ERROR —

- **DTC DETECTING CONDITION:**
 - Two consecutive driving cycles with fault
- **TROUBLE SYMPTOM:**
 - Engine does not start.
 - Engine stalls.

CAUTION:

After repair or replacement of faulty parts, conduct **CLEAR MEMORY MODE** <Ref. to 2-7 [T3D0].> and **INSPECTION MODE** <Ref. to 2-7 [T3E0].>

● **WIRING DIAGRAM:**

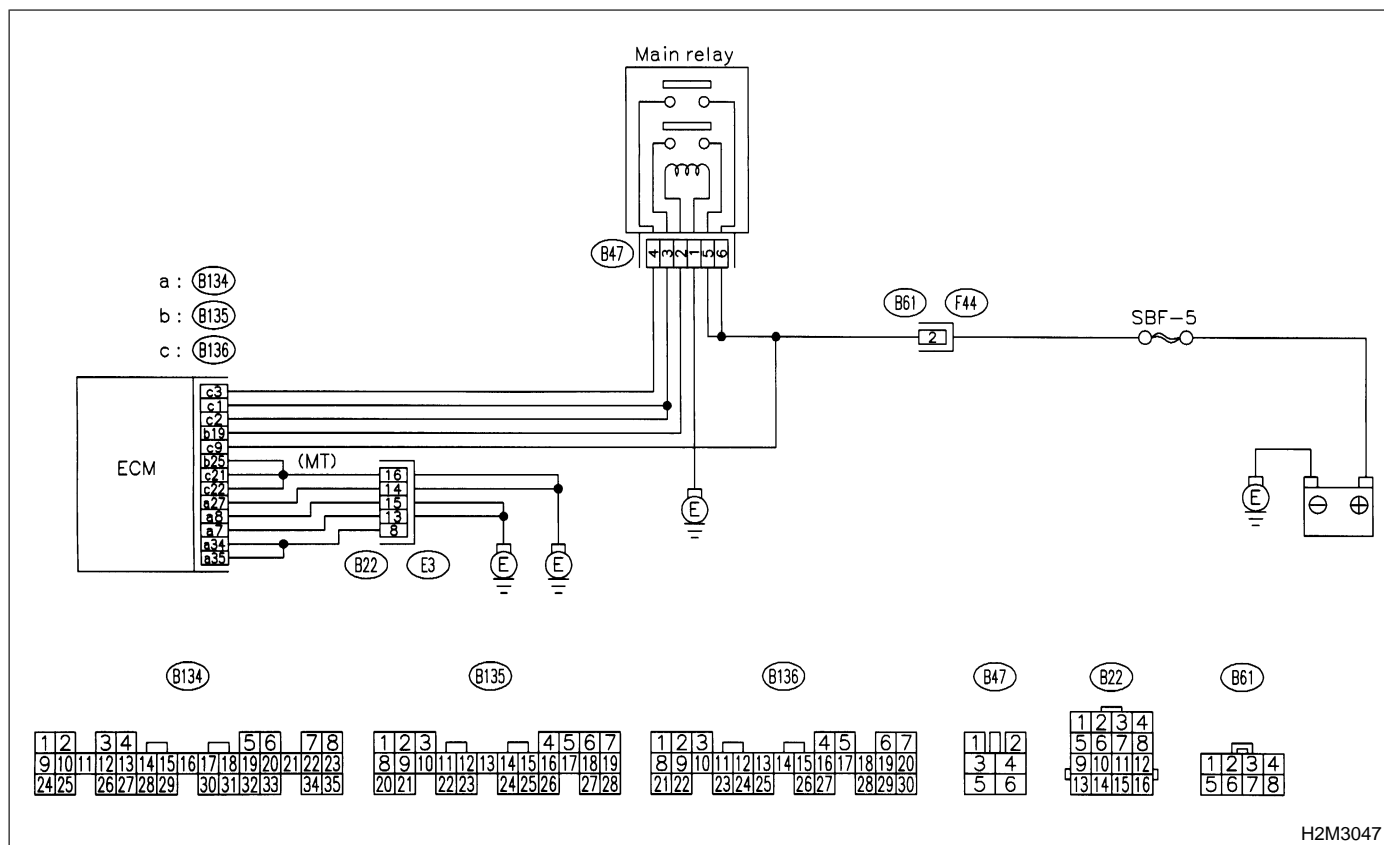

H2M3047

11AV1 : CHECK ANY OTHER DTC ON DISPLAY.

- CHECK** : Does the Subaru Select Monitor or OBD-II general scan tool indicate DTC P0601?
- YES** : Replace ECM. <Ref. to 2-7 [W15A0].>
- NO** : It is not necessary to inspect DTC P0601.

2-7 [T11AV1]

ON-BOARD DIAGNOSTICS II SYSTEM

11. Diagnostics Chart with Trouble Code for Except 2200 cc California Spec. Vehicles

MEMO:

AW: DTC P0703 — BRAKE SWITCH INPUT MALFUNCTION —

- **DTC DETECTING CONDITION:**
 - Two consecutive driving cycles with fault

CAUTION:

After repair or replacement of faulty parts, conduct CLEAR MEMORY MODE <Ref. to 2-7 [T3D0].> and INSPECTION MODE <Ref. to 2-7 [T3E0].>

● **WIRING DIAGRAM:**

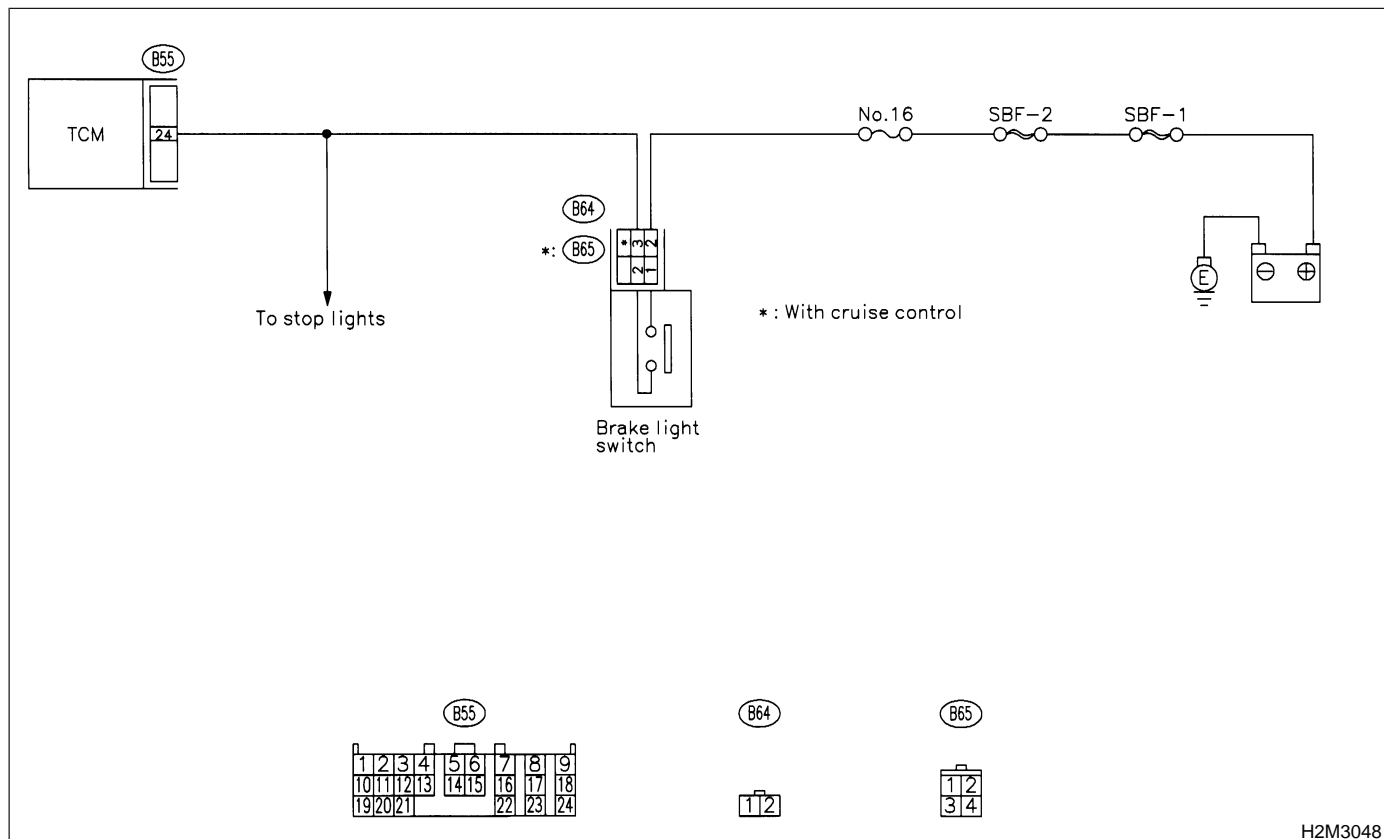

H2M3048

11AW1 : CHECK OPERATION OF BRAKE LIGHT.

- CHECK** : Does brake light come on when depressing the brake pedal?
- YES** : Go to step 11AW2.
- NO** : Repair or replace brake light circuit.

11AW2 : CHECK HARNESS BETWEEN TCM AND BRAKE LIGHT SWITCH CONNECTOR.

- 1) Disconnect connectors from TCM and brake light switch.
- 2) Measure resistance of harness between TCM and brake light switch connector.

Connector & terminal

(B55) No. 24 — (B64) No. 2:

(B55) No. 24 — (B65) No. 3 (With cruise control):

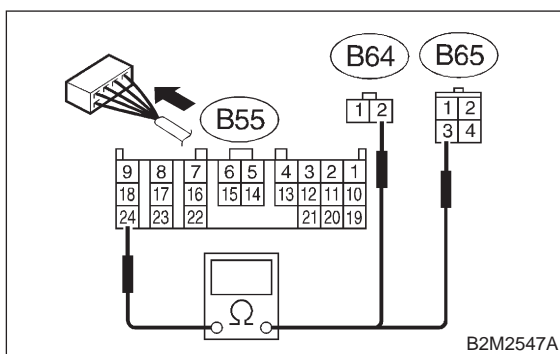

CHECK : Is the resistance less than 1 Ω?

YES : Go to step 11AW3.

NO : Repair or replace harness and connector.

NOTE:

In this case, repair the following:

- Open circuit in harness between TCM and brake light switch connector
- Poor contact in TCM connector
- Poor contact in brake light switch connector

11AW3 : CHECK HARNESS BETWEEN TCM AND BRAKE LIGHT SWITCH CONNECTOR.

Measure resistance of harness between TCM and chassis ground.

Connector & terminal

(B55) No. 24 — Chassis ground:

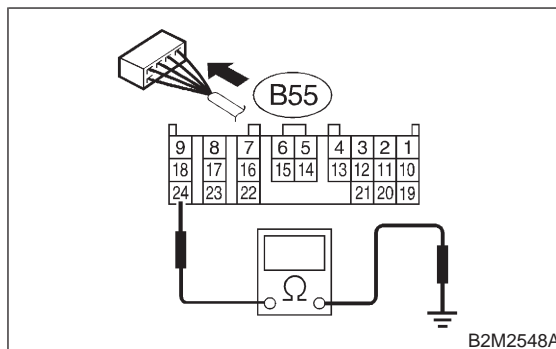

CHECK : Is the resistance more than 1 MΩ?

YES : Go to step 11AW4.

NO : Repair ground short circuit in harness between TCM and brake light switch connector.

11AW4 : CHECK INPUT SIGNAL FOR TCM.

- 1) Connect connectors to TCM and brake light switch.
- 2) Measure voltage between TCM and chassis ground.

Connector & terminal

(B55) No. 24 (+) — Chassis ground (-):

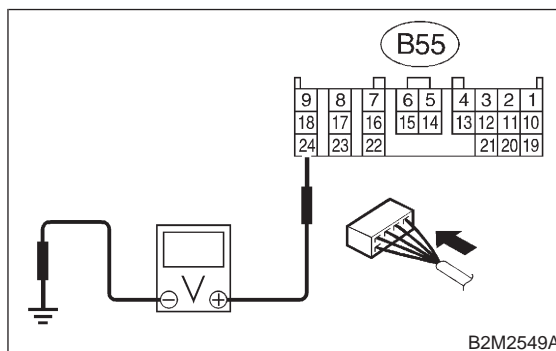

CHECK : Is the voltage less than 1 V when releasing the brake pedal?

YES : Go to step 11AW5.

NO : Adjust or replace brake light switch. <Ref. to 4-5 [W1A0].>

11AW5 : CHECK INPUT SIGNAL FOR TCM.

Measure voltage between TCM and chassis ground.

Connector & terminal

(B55) No. 24 (+) — Chassis ground (-):

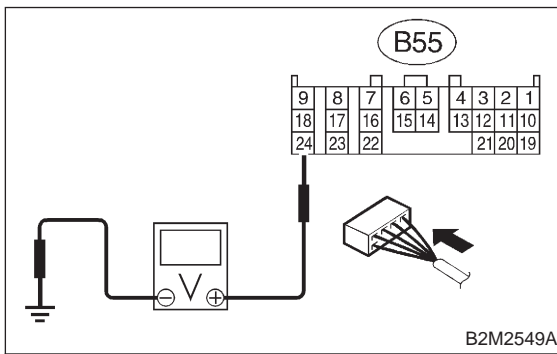

- CHECK** : *Is the voltage more than 10 V when depressing the brake pedal?*
- YES** : Go to step 11AW6.
- NO** : Adjust or replace brake light switch. <Ref. to 4-5 [W1A0].>

11AW6 : CHECK POOR CONTACT.

Check poor contact in TCM connector. <Ref. to FOREWORD [T3C1].>

- CHECK** : *Is there poor contact in TCM connector?*
- YES** : Repair poor contact in TCM connector.
- NO** : Replace TCM. <Ref. to 3-2 [W22A0].>

MEMO:

AX: DTC P0705 — TRANSMISSION RANGE SENSOR CIRCUIT MALFUNCTION —

● DTC DETECTING CONDITION:

- Two consecutive driving cycles with fault

● TROUBLE SYMPTOM:

- Starter does not rotate when selector lever is in “P” or “N” range.
- Starter rotates when selector lever is in “R”, “D”, “3”, “2” or “1” range.
- Engine brake is not effected when selector lever is in “3” range.
- Shift characteristics are erroneous.

CAUTION:

After repair or replacement of faulty parts, conduct CLEAR MEMORY MODE <Ref. to 2-7 [T3D0].> and INSPECTION MODE <Ref. to 2-7 [T3E0].>

● WIRING DIAGRAM:

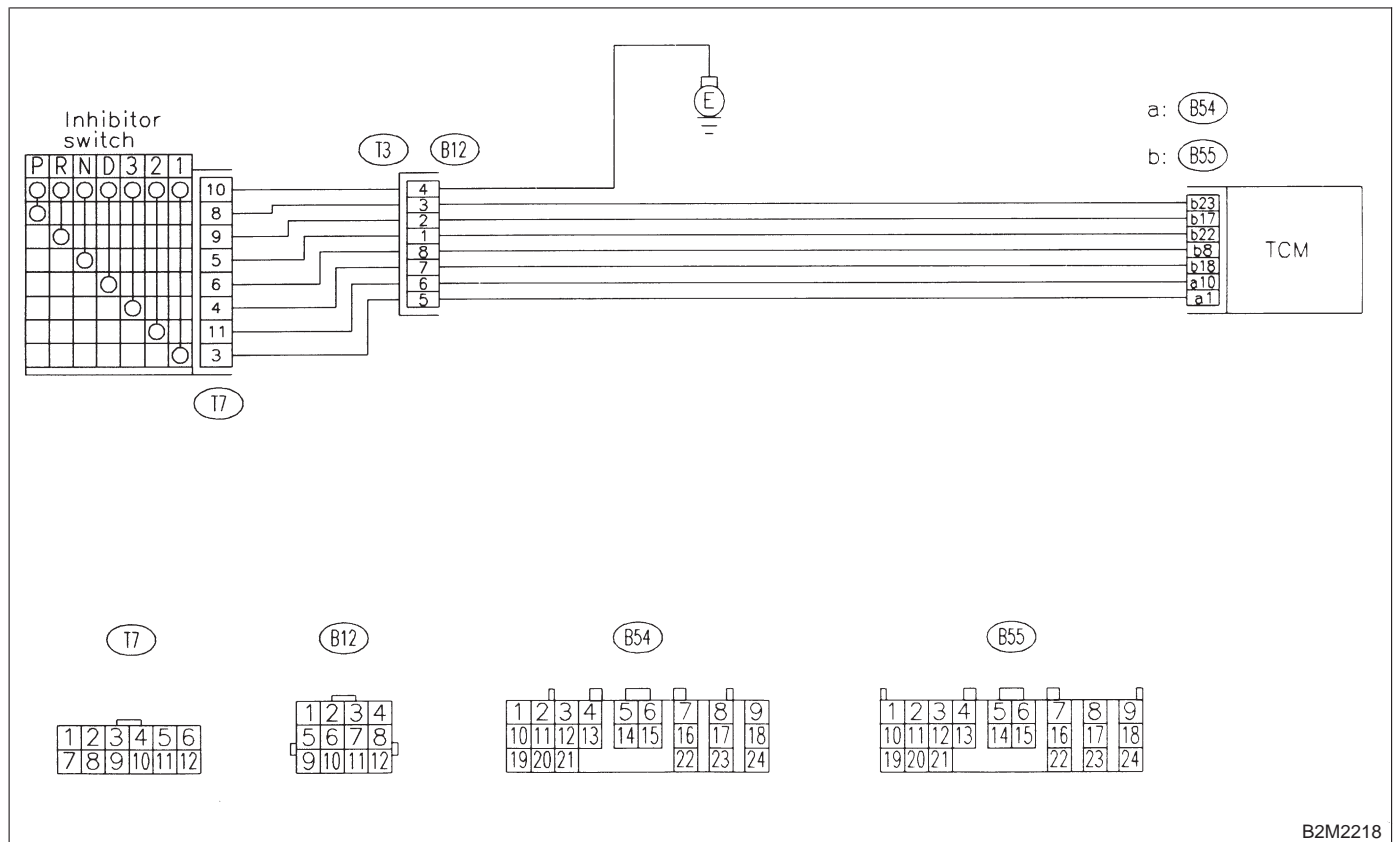

B2M2218

2-7 [T11AX1]

ON-BOARD DIAGNOSTICS II SYSTEM

11. Diagnostics Chart with Trouble Code for Except 2200 cc California Spec. Vehicles

11AX1 : CHECK HARNESS BETWEEN TCM AND INHIBITOR SWITCH CONNECTOR.

- 1) Turn ignition switch to OFF.
- 2) Disconnect connectors from TCM and transmission.
- 3) Measure resistance of harness between TCM and transmission harness connector.

Connector & terminal

(B55) No. 23 — (T7) No. 8:

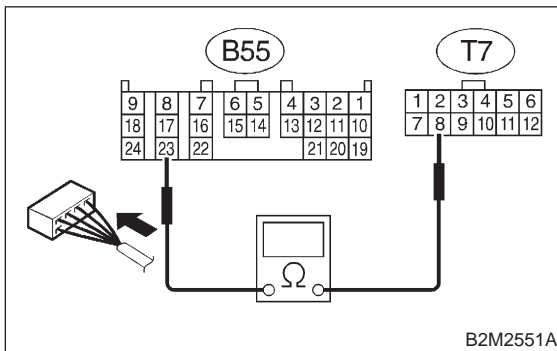

- CHECK** : Is the resistance less than 1 Ω?
YES : Go to step 11AX2.
NO : Repair harness and connector.

NOTE:

In this case, repair the following:

- Open circuit in harness between ECM and inhibitor switch connector
- Poor contact in coupling connector (B12)

11AX2 : CHECK HARNESS BETWEEN TCM AND INHIBITOR SWITCH CONNECTOR.

Measure resistance of harness between TCM and transmission harness connector.

Connector & terminal

(B55) No. 17 — (T7) No. 9:

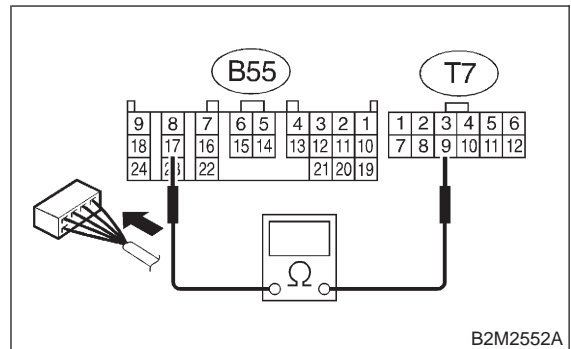

- CHECK** : Is the resistance less than 1 Ω?
YES : Go to step 11AX3.
NO : Repair harness and connector.

NOTE:

In this case, repair the following:

- Open circuit in harness between ECM and inhibitor switch connector
- Poor contact in coupling connector (B12)

11AX3 : CHECK HARNESS BETWEEN TCM AND INHIBITOR SWITCH CONNECTOR.

Measure resistance of harness between TCM and transmission harness connector.

Connector & terminal

(B55) No. 22 — (T7) No. 5:

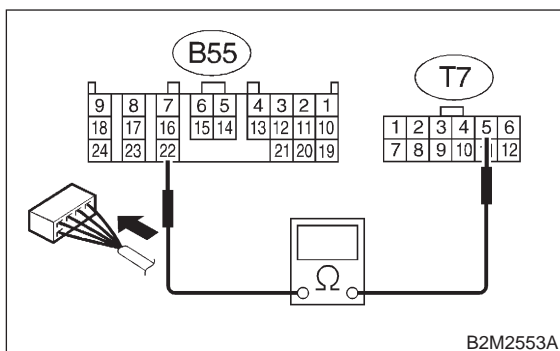

- CHECK** : *Is the resistance less than 1 Ω?*
- YES** : Go to step **11AX4**.
- NO** : Repair harness and connector.

NOTE:

In this case, repair the following:

- Open circuit in harness between ECM and inhibitor switch connector.
- Poor contact in coupling connector (B12)

11AX4 : CHECK HARNESS BETWEEN TCM AND INHIBITOR SWITCH CONNECTOR.

Measure resistance of harness between TCM and transmission harness connector.

Connector & terminal

(B55) No. 8 — (T7) No. 6:

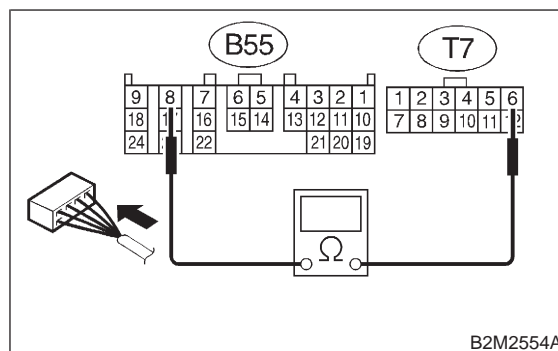

- CHECK** : *Is the resistance less than 1 Ω?*
- YES** : Go to step **11AX5**.
- NO** : Repair harness and connector.

NOTE:

In this case, repair the following:

- Open circuit in harness between ECM and inhibitor switch connector.
- Poor contact in coupling connector (B12)

2-7 [T11AX5]

ON-BOARD DIAGNOSTICS II SYSTEM

11. Diagnostics Chart with Trouble Code for Except 2200 cc California Spec. Vehicles

11AX5 : CHECK HARNESS BETWEEN TCM AND INHIBITOR SWITCH CONNECTOR.

Measure resistance of harness between TCM and transmission harness connector.

Connector & terminal

(B55) No. 18 — (T7) No. 4:

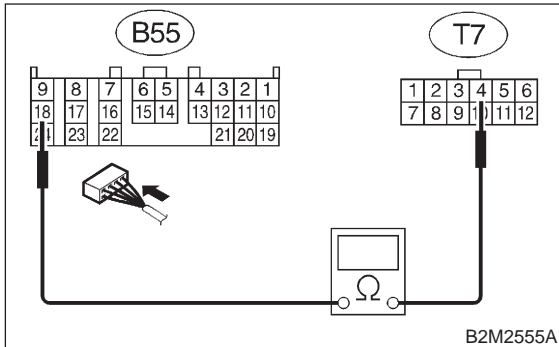

CHECK : *Is the resistance less than 1 Ω ?*

YES : Go to step 11AX6.

NO : Repair harness and connector.

NOTE:

In this case, repair the following:

- Open circuit in harness between ECM and inhibitor switch connector.
- Poor contact in coupling connector (B12)

11AX6 : CHECK HARNESS BETWEEN TCM AND INHIBITOR SWITCH CONNECTOR.

Measure resistance of harness between TCM and transmission harness connector.

Connector & terminal

(B54) No. 10 — (T7) No. 11:

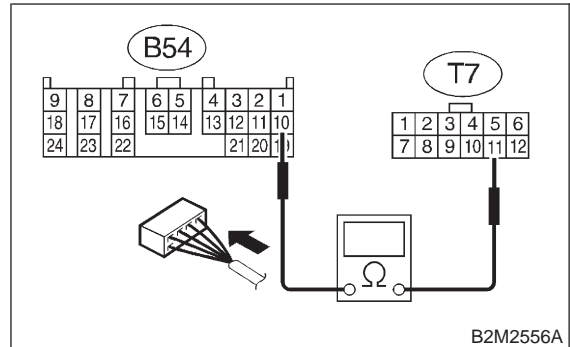

CHECK : *Is the resistance less than 1 Ω ?*

YES : Go to step 11AX7.

NO : Repair harness and connector.

NOTE:

In this case, repair the following:

- Open circuit in harness between ECM and inhibitor switch connector.
- Poor contact in coupling connector (B12)

11AX7 : CHECK HARNESS BETWEEN TCM AND INHIBITOR SWITCH CONNECTOR.

Measure resistance of harness between TCM and transmission harness connector.

Connector & terminal
(B54) No. 1 — (T7) No. 3:

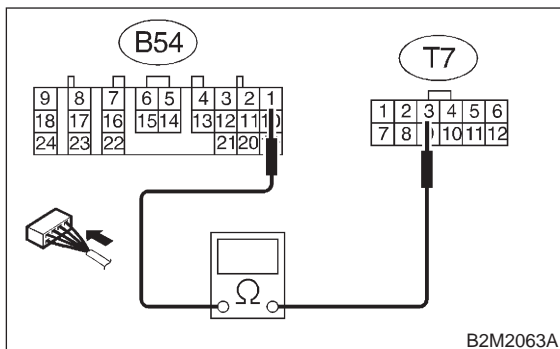

- CHECK** : Is the resistance less than 1 Ω?
- YES** : Go to step 11AX8.
- NO** : Repair harness and connector.

NOTE:

In this case, repair the following:

- Open circuit in harness between ECM and inhibitor switch connector.
- Poor contact in coupling connector (B12)

11AX8 : CHECK HARNESS BETWEEN TCM AND INHIBITOR SWITCH CONNECTOR.

Measure resistance of harness between TCM and chassis ground.

Connector & terminal
(B55) No. 23 — Chassis ground:

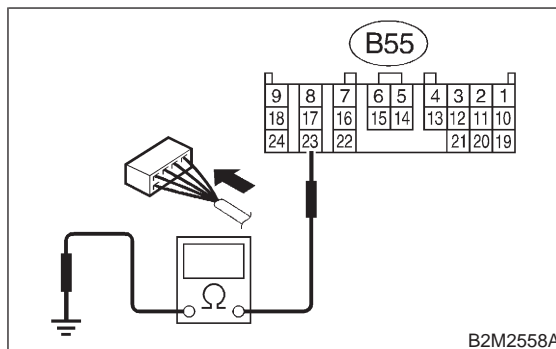

- CHECK** : Is the resistance more than 1 MΩ?
- YES** : Go to step 11AX9.
- NO** : Repair ground short circuit in harness between TCM and transmission harness connector.

11AX9 : CHECK HARNESS BETWEEN TCM AND INHIBITOR SWITCH CONNECTOR.

Measure resistance of harness between TCM and chassis ground.

Connector & terminal
(B55) No. 17 — Chassis ground:

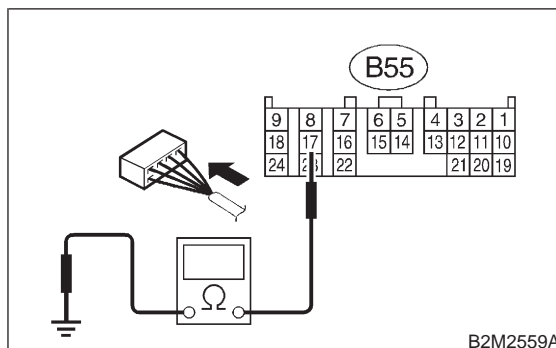

- CHECK** : Is the resistance more than 1 MΩ?
- YES** : Go to step 11AX10.
- NO** : Repair ground short circuit in harness between TCM and transmission harness connector.

11AX10 : CHECK HARNESS BETWEEN TCM AND INHIBITOR SWITCH CONNECTOR.

Measure resistance of harness between TCM and chassis ground.

Connector & terminal
(B55) No. 22 — Chassis ground:

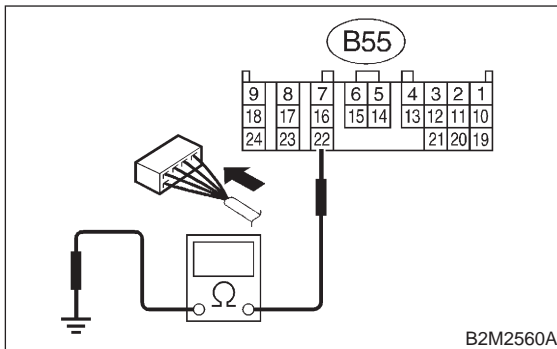

- CHECK** : Is the resistance more than 1 MΩ?
- YES** : Go to step 11AX11.
- NO** : Repair ground short circuit in harness between TCM and transmission harness connector.

11AX12 : CHECK HARNESS BETWEEN TCM AND INHIBITOR SWITCH CONNECTOR.

Measure resistance of harness between TCM and chassis ground.

Connector & terminal
(B55) No. 18 — Chassis ground:

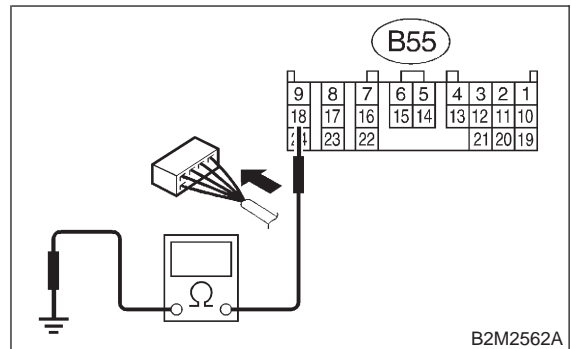

- CHECK** : Is the resistance more than 1 MΩ?
- YES** : Go to step 11AX13.
- NO** : Repair ground short circuit in harness between TCM and transmission harness connector.

11AX11 : CHECK HARNESS BETWEEN TCM AND INHIBITOR SWITCH CONNECTOR.

Measure resistance of harness between TCM and chassis ground.

Connector & terminal
(B55) No. 8 — Chassis ground:

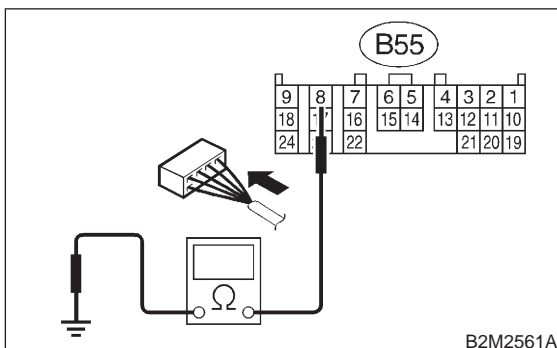

- CHECK** : Is the resistance more than 1 MΩ?
- YES** : Go to step 11AX12.
- NO** : Repair ground short circuit in harness between TCM and transmission harness connector.

11AX13 : CHECK HARNESS BETWEEN TCM AND INHIBITOR SWITCH CONNECTOR.

Measure resistance of harness between TCM and chassis ground.

Connector & terminal
(B54) No. 10 — Chassis ground:

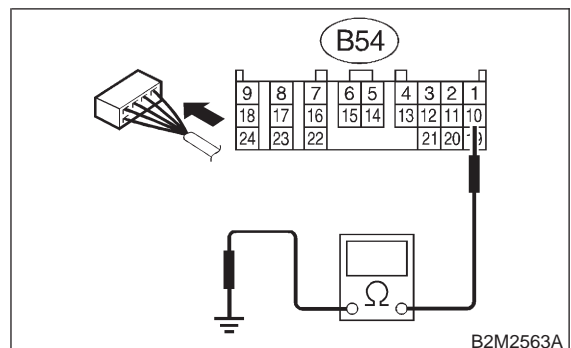

- CHECK** : Is the resistance more than 1 MΩ?
- YES** : Go to step 11AX14.
- NO** : Repair ground short circuit in harness between TCM and transmission harness connector.

11AX14 : CHECK HARNESS BETWEEN TCM AND INHIBITOR SWITCH CONNECTOR.

Measure resistance of harness between TCM and chassis ground.

Connector & terminal
(B54) No. 1 — Chassis ground:

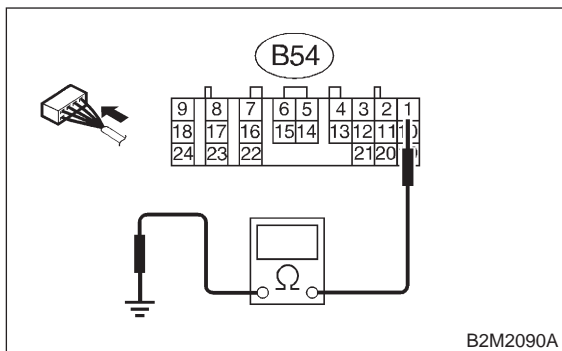

- CHECK** : *Is the resistance more than 1 MΩ?*
- YES** : Go to step 11AX15.
- NO** : Repair ground short circuit in harness between TCM and transmission harness connector.

11AX15 : CHECK INHIBITOR SWITCH.

Measure resistance between inhibitor switch connector receptacle's terminals in selector lever "P" position.

Terminals
No. 8 — No. 10:

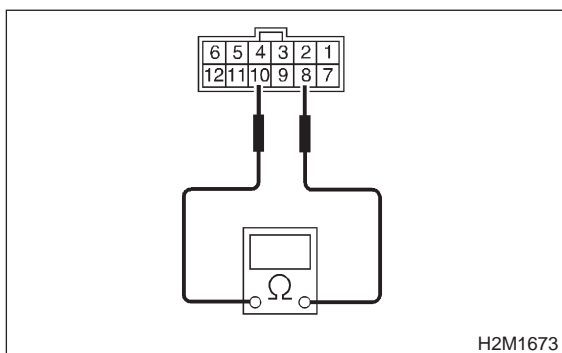

- CHECK** : *Is the resistance less than 1 Ω?*
- YES** : Go to step 11AX16.
- NO** : Go to step 11AX29.

11AX16 : CHECK INHIBITOR SWITCH.

Measure resistance between inhibitor switch connector receptacle's terminals in selector lever except for "P" position.

Terminals
No. 8 — No. 10:

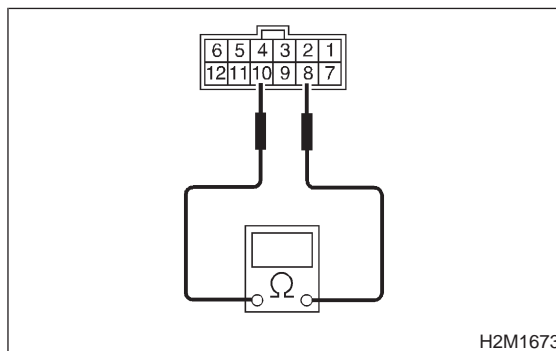

- CHECK** : *Is the resistance more than 1 MΩ?*
- YES** : Go to step 11AX17.
- NO** : Go to step 11AX29.

11AX17 : CHECK INHIBITOR SWITCH.

Measure resistance between inhibitor switch connector receptacle's terminals in selector lever for "R" position.

Terminals
No. 9 — No. 10:

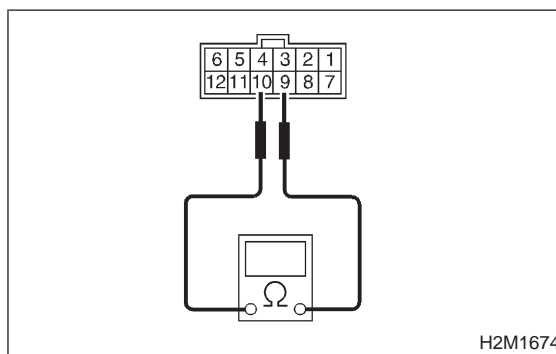

- CHECK** : *Is the resistance less than 1 Ω?*
- YES** : Go to step 11AX18.
- NO** : Go to step 11AX29.

2-7 [T11AX18]

ON-BOARD DIAGNOSTICS II SYSTEM

11. Diagnostics Chart with Trouble Code for Except 2200 cc California Spec. Vehicles

11AX18 : CHECK INHIBITOR SWITCH.

Measure resistance between inhibitor switch connector receptacle's terminals in selector lever except for "R" position.

Terminals

No. 9 — No. 10:

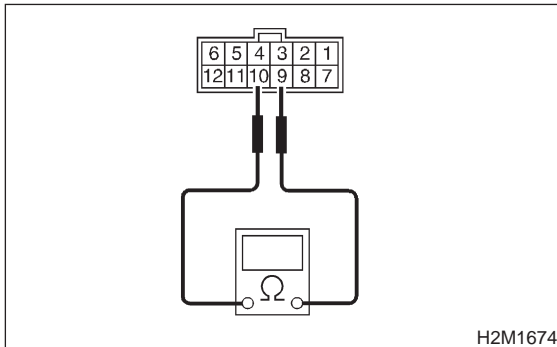

H2M1674

- CHECK** : Is the resistance more than 1 MΩ?
YES : Go to step 11AX19.
NO : Go to step 11AX29.

11AX20 : CHECK INHIBITOR SWITCH.

Measure resistance between inhibitor switch connector receptacle's terminals in selector lever except for "N" position.

Terminals

No. 5 — No. 10:

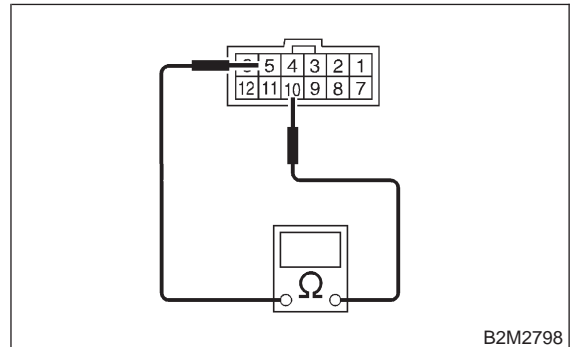

B2M2798

- CHECK** : Is the resistance more than 1 MΩ?
YES : Go to step 11AX21.
NO : Go to step 11AX29.

11AX19 : CHECK INHIBITOR SWITCH.

Measure resistance between inhibitor switch connector receptacle's terminals in selector lever for "N" position.

Terminals

No. 5 — No. 10:

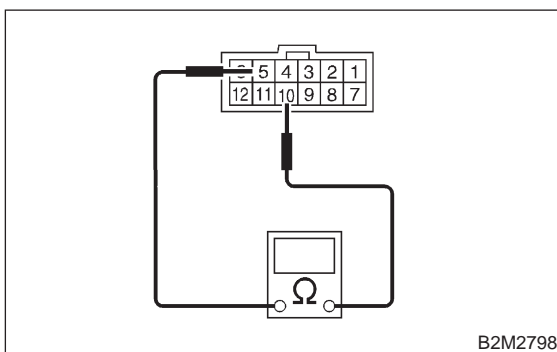

B2M2798

- CHECK** : Is the resistance less than 1 Ω?
YES : Go to step 11AX20.
NO : Go to step 11AX29.

11AX21 : CHECK INHIBITOR SWITCH.

Measure resistance between inhibitor switch connector receptacle's terminals in selector lever except for "D" position.

Terminals

No. 6 — No. 10:

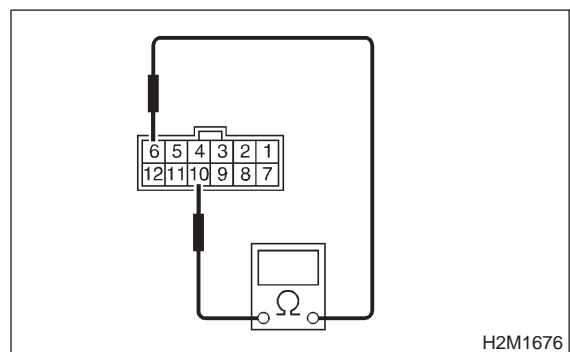

H2M1676

- CHECK** : Is the resistance less than 1 Ω?
YES : Go to step 11AX22.
NO : Go to step 11AX29.

11AX22 : CHECK INHIBITOR SWITCH.

Measure resistance between inhibitor switch connector receptacle's terminals in selector lever except for "D" position.

Terminals

No. 6 — No. 10:

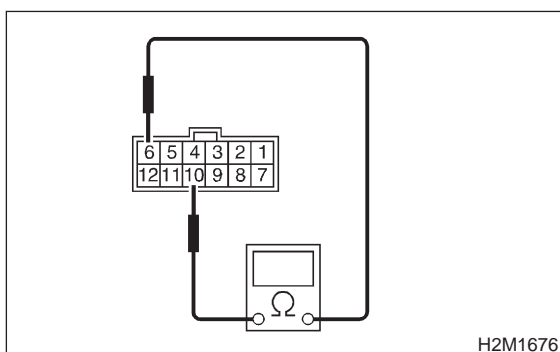

CHECK : *Is the resistance more than 1 MΩ?*

YES : Go to step 11AX23.

NO : Go to step 11AX29.

11AX23 : CHECK INHIBITOR SWITCH.

Measure resistance between inhibitor switch connector receptacle's terminals in selector lever for "3" position.

Terminals

No. 4 — No. 10:

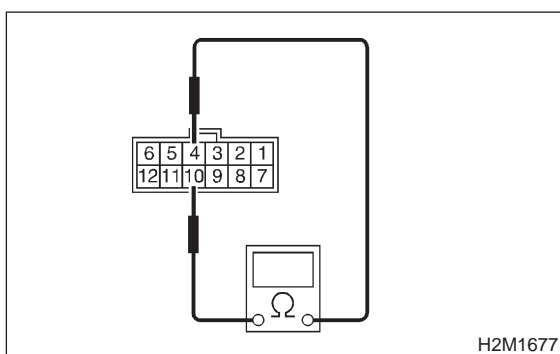

CHECK : *Is the resistance less than 1 Ω?*

YES : Go to step 11AX24.

NO : Go to step 11AX29.

11AX24 : CHECK INHIBITOR SWITCH.

Measure resistance between inhibitor switch connector receptacle's terminals in selector lever except for "3" position.

Terminals

No. 4 — No. 10:

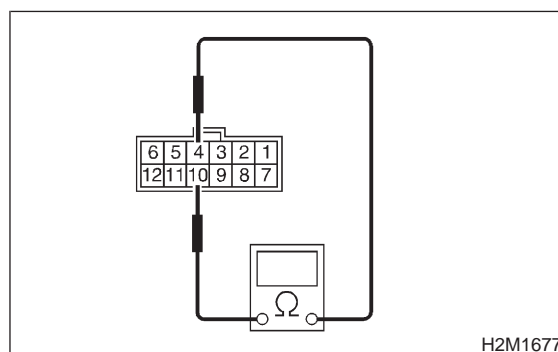

CHECK : *Is the resistance more than 1 MΩ?*

YES : Go to step 11AX25.

NO : Go to step 11AX29.

11AX25 : CHECK INHIBITOR SWITCH.

Measure resistance between inhibitor switch connector receptacle's terminals in selector lever except for "2" position.

Terminals

No. 11 — No. 10:

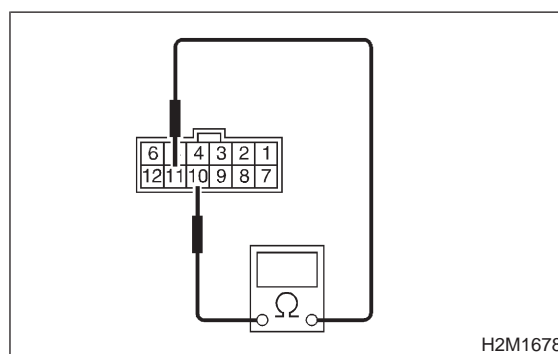

CHECK : *Is the resistance less than 1 Ω?*

YES : Go to step 11AX26.

NO : Go to step 11AX29.

2-7 [T11AX26]

ON-BOARD DIAGNOSTICS II SYSTEM

11. Diagnostics Chart with Trouble Code for Except 2200 cc California Spec. Vehicles

11AX26 : CHECK INHIBITOR SWITCH.

Measure resistance between inhibitor switch connector receptacle's terminals in selector lever except for "R" position.

Terminals

No. 11 — No. 10:

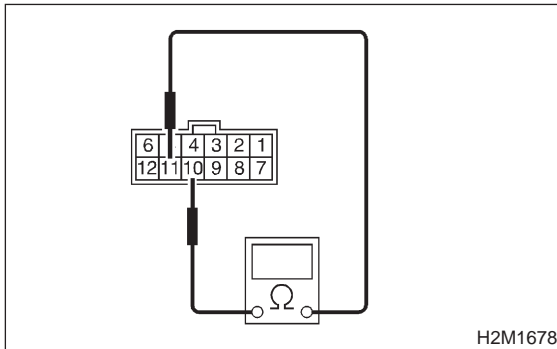

- CHECK** : *Is the resistance more than 1 MΩ?*
YES : Go to step 11AX27.
NO : Go to step 11AX29.

11AX27 : CHECK INHIBITOR SWITCH.

Measure resistance between inhibitor switch connector receptacle's terminals in selector lever except for "1" position.

Terminals

No. 3 — No. 10:

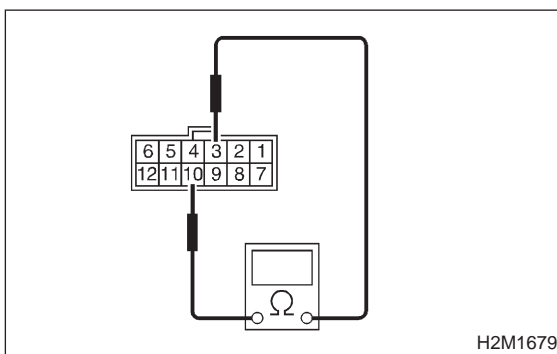

- CHECK** : *Is the resistance less than 1 Ω?*
YES : Go to step 11AX28.
NO : Go to step 11AX29.

11AX28 : CHECK INHIBITOR SWITCH.

Measure resistance between inhibitor switch connector receptacle's terminals in selector lever except for "1" position.

Terminals

No. 3 — No. 10:

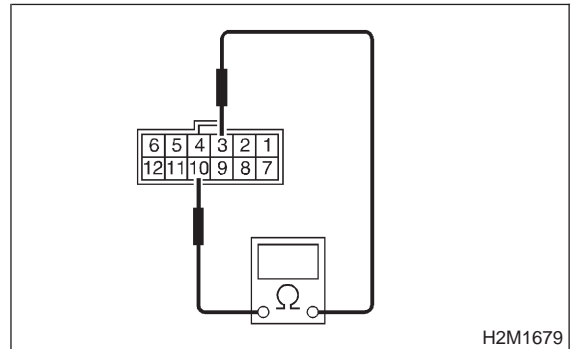

- CHECK** : *Is the resistance more than 1 MΩ?*
YES : Go to step 11AX30.
NO : Go to step 11AX29.

11AX29 : CHECK SELECTOR CABLE.

- CHECK** : *Is there faulty connection in the selector cable?*
YES : Repair connection of selector cable.
NO : Replace inhibitor switch. <Ref. to 3-2 [W2C0].>

11AX30 : CHECK INPUT SIGNAL FOR TCM.

- 1) Turn ignition switch to OFF.
- 2) Connect connector to TCM and transmission.
- 3) Turn ignition switch to ON.
- 4) Measure voltage between TCM and chassis ground.

Connector & terminal
(B55) No. 23 (+) — Chassis ground (-):

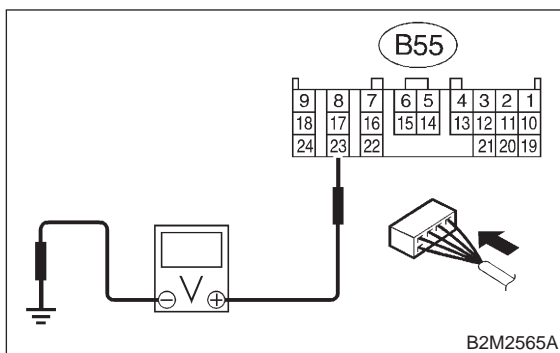

- CHECK** : *Is the voltage less than 1 V?*
- YES** : Go to step 11AX31.
- NO** : Go to step 11AX44.

11AX31 : CHECK INPUT SIGNAL FOR TCM.

Measure voltage between TCM chassis ground in selector lever except for "P" and "N" positions.

Connector & terminal
(B55) No. 23 (+) — Chassis ground (-):

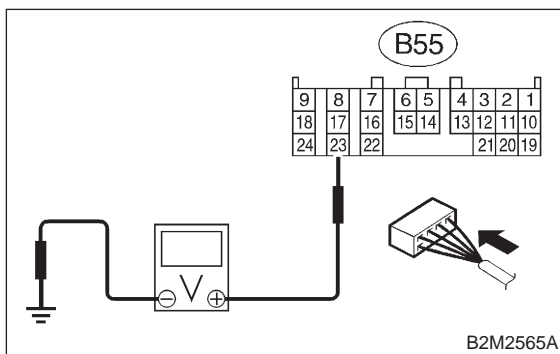

- CHECK** : *Is the voltage more than 8 V?*
- YES** : Go to step 11AX32.
- NO** : Go to step 11AX44.

11AX32 : CHECK INPUT SIGNAL FOR TCM.

Measure voltage between TCM chassis ground in selector lever "R" position.

Connector & terminal
(B55) No. 17 (+) — Chassis ground (-):

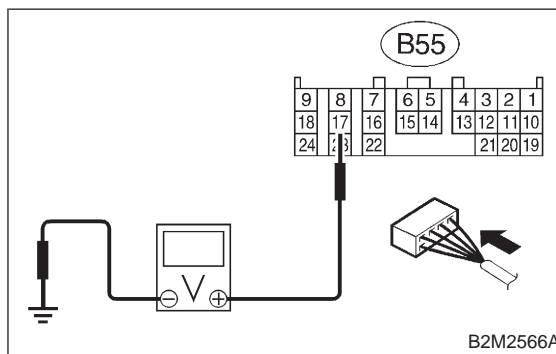

- CHECK** : *Is the voltage less than 1 V?*
- YES** : Go to step 11AX33.
- NO** : Go to step 11AX44.

11AX33 : CHECK INPUT SIGNAL FOR TCM.

Measure voltage between TCM chassis ground in selector lever except for "R" position.

Connector & terminal
(B55) No. 17 (+) — Chassis ground (-):

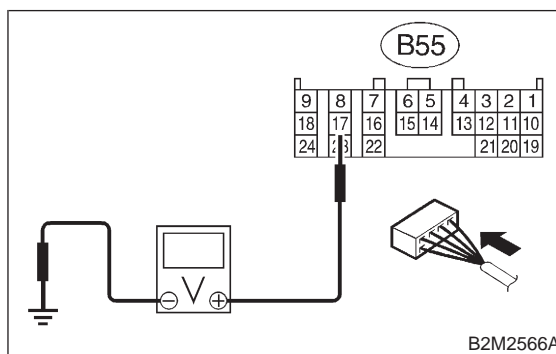

- CHECK** : *Is the voltage more than 6 V?*
- YES** : Go to step 11AX34.
- NO** : Go to step 11AX44.

2-7 [T11AX34]

ON-BOARD DIAGNOSTICS II SYSTEM

11. Diagnostics Chart with Trouble Code for Except 2200 cc California Spec. Vehicles

11AX34 : CHECK INPUT SIGNAL FOR TCM.

Measure voltage between TCM chassis ground in selector lever "P" and "N" positions.

Connector & terminal

(B55) No. 22 (+) — Chassis ground (-):

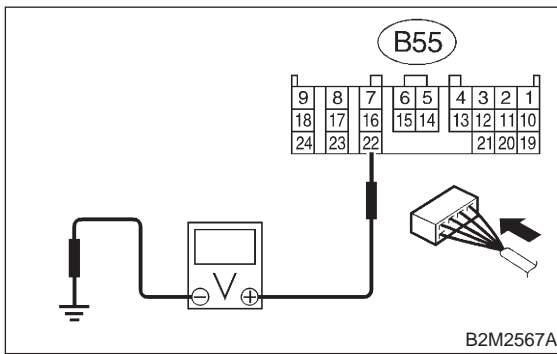

- CHECK** : Is the voltage less than 1 V?
YES : Go to step 11AX35.
NO : Go to step 11AX44.

11AX36 : CHECK INPUT SIGNAL FOR TCM.

Measure voltage between TCM and chassis ground in selector lever "D" position.

Connector & terminal

(B55) No. 8 (+) — Chassis ground (-):

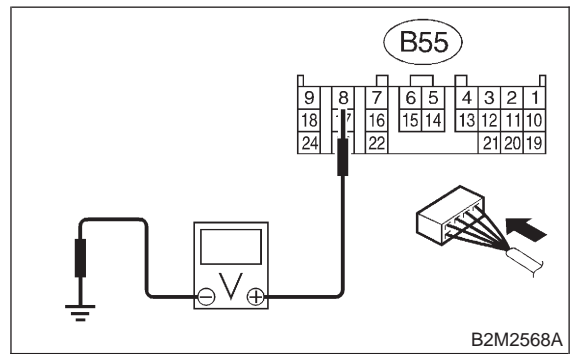

- CHECK** : Is the voltage less than 1 V?
YES : Go to step 11AX37.
NO : Go to step 11AX44.

11AX35 : CHECK INPUT SIGNAL FOR TCM.

Measure voltage between TCM chassis ground in selector lever except for "N" and "P" positions.

Connector & terminal

(B55) No. 22 (+) — Chassis ground (-):

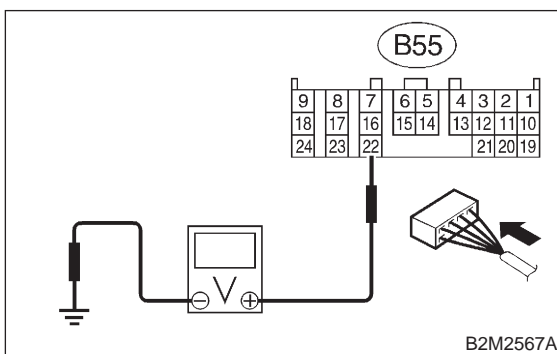

- CHECK** : Is the voltage more than 8 V?
YES : Go to step 11AX36.
NO : Go to step 11AX44.

11AX37 : CHECK INPUT SIGNAL FOR TCM.

Measure voltage between TCM chassis ground in selector lever except for "N" and "P" positions.

Connector & terminal

(B55) No. 8 (+) — Chassis ground (-):

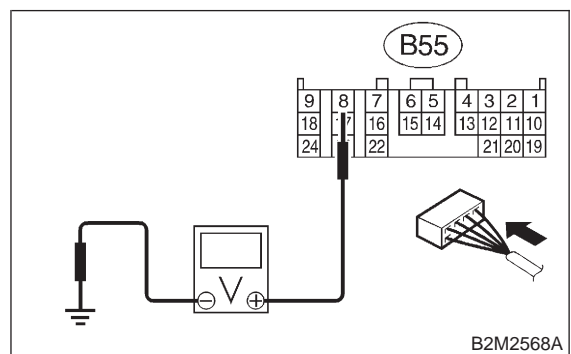

- CHECK** : Is the voltage more than 6 V?
YES : Go to step 11AX38.
NO : Go to step 11AX44.

11AX38 : CHECK INPUT SIGNAL FOR TCM.

Measure voltage between TCM chassis ground in selector lever "3" position.

Connector & terminal
(B55) No. 18 (+) — Chassis ground (-):

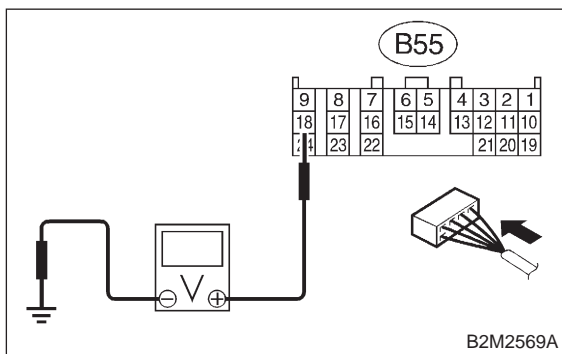

- CHECK** : Is the voltage less than 1 V?
- YES** : Go to step 11AX39.
- NO** : Go to step 11AX44.

11AX39 : CHECK INPUT SIGNAL FOR TCM.

Measure voltage between TCM and chassis ground in selector lever except for "3" position.

Connector & terminal
(B55) No. 18 (+) — Chassis ground (-):

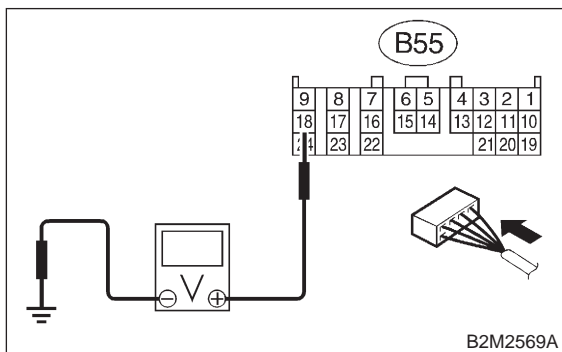

- CHECK** : Is the voltage more than 6 V?
- YES** : Go to step 11AX40.
- NO** : Go to step 11AX44.

11AX40 : CHECK INPUT SIGNAL FOR TCM.

Measure voltage between TCM chassis ground in selector lever "2" position.

Connector & terminal
(B54) No. 10 (+) — Chassis ground (-):

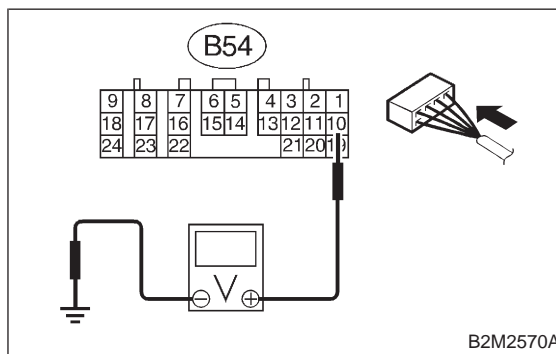

- CHECK** : Is the voltage less than 1 V?
- YES** : Go to step 11AX41.
- NO** : Go to step 11AX44.

11AX41 : CHECK INPUT SIGNAL FOR TCM.

Measure voltage between TCM and chassis ground in selector lever except for "2" position.

Connector & terminal
(B54) No. 10 (+) — Chassis ground (-):

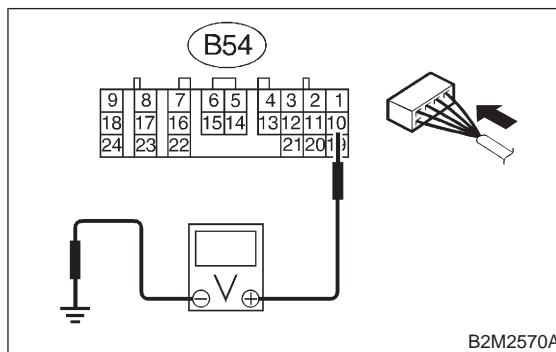

- CHECK** : Is the voltage more than 6 V?
- YES** : Go to step 11AX42.
- NO** : Go to step 11AX44.

2-7 [T11AX42]

ON-BOARD DIAGNOSTICS II SYSTEM

11. Diagnostics Chart with Trouble Code for Except 2200 cc California Spec. Vehicles

11AX42 : CHECK INPUT SIGNAL FOR TCM.

Measure voltage between TCM chassis ground in selector lever "1" position.

Connector & terminal

(B54) No. 1 (+) — Chassis ground (-):

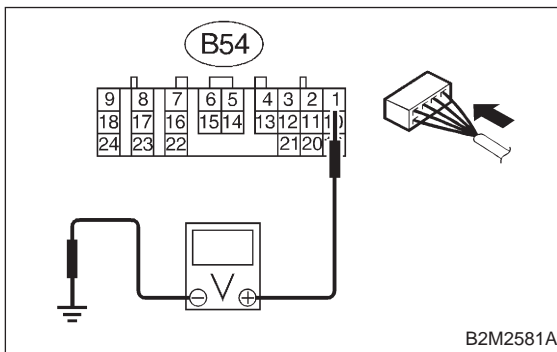

CHECK : Is the voltage less than 1 V?

YES : Go to step 11AX43.

NO : Go to step 11AX44.

11AX43 : CHECK INPUT SIGNAL FOR TCM.

Measure voltage between TCM chassis ground in selector lever except for "1" position.

Connector & terminal

(B54) No. 1 (+) — Chassis ground (-):

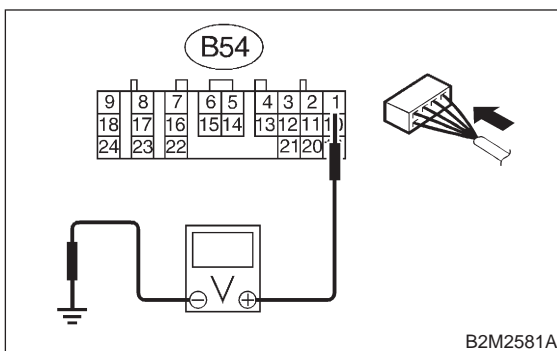

CHECK : Is the voltage more than 6 V?

YES : Repair poor contact in TCM connector.

NO : Go to step 11AX44.

11AX44 : CHECK POOR CONTACT.

Check poor contact in TCM connector. <Ref. to FOREWORD [T3C1].>

CHECK : Is there poor contact in TCM connector?

YES : Repair poor contact in TCM connector.

NO : Replace TCM. <Ref. to 3-2 [W22A0].>

AY: DTC P0710 — TRANSMISSION FLUID TEMPERATURE SENSOR CIRCUIT MALFUNCTION —

● **DTC DETECTING CONDITION:**

- Two consecutive driving cycles with fault

● **TROUBLE SYMPTOM:**

- No shift up to 4th speed (after engine warm-up)
- No lock-up (after engine warm-up)
- Excessive shift shock

CAUTION:

After repair or replacement of faulty parts, conduct CLEAR MEMORY MODE <Ref. to 2-7 [T3D0].> and INSPECTION MODE <Ref. to 2-7 [T3E0].>

● **WIRING DIAGRAM:**

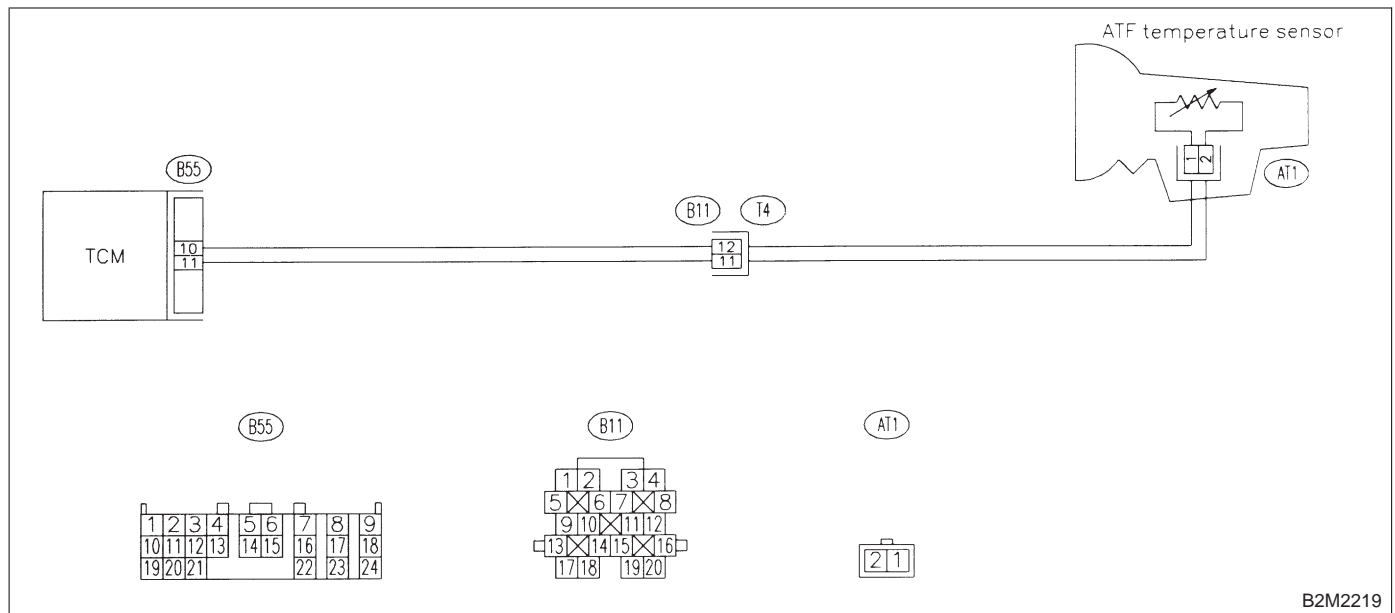

B2M2219

11AY1 : CHECK DTC P0710 ON DISPLAY.

- CHECK** : Does the Subaru Select Monitor or OBD-II general scan tool indicate DTC P0710?
- YES** : Check ATF temperature sensor circuit. <Ref. to 3-2 [T8E0].>
- NO** : It is not necessary to inspect DTC P0710.

AZ: DTC P0715 — TORQUE CONVERTER TURBINE SPEED SENSOR CIRCUIT MALFUNCTION —

- **DTC DETECTING CONDITION:**
 - Two consecutive driving cycles with fault

CAUTION:

After repair or replacement of faulty parts, conduct CLEAR MEMORY MODE <Ref. to 2-7 [T3D0].> and INSPECTION MODE <Ref. to 2-7 [T3E0].>

- **WIRING DIAGRAM:**

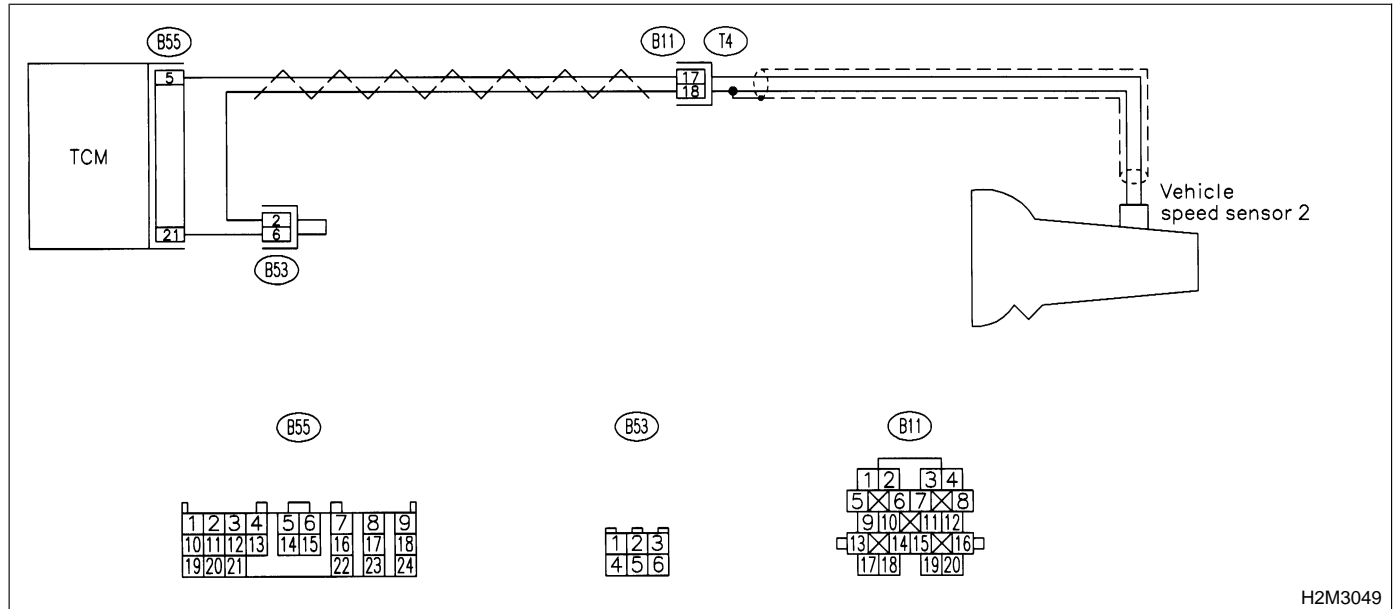

H2M3049

11AZ1 : CHECK DTC P0715 ON DISPLAY.

CHECK : Does the Subaru Select Monitor or OBD-II general scan tool indicate DTC P0715?

YES : Check torque converter turbine speed sensor circuit. <Ref. to 3-2 [T8H0].>

NO : It is not necessary to inspect DTC P0715.

BA: DTC P0720 — OUTPUT SPEED SENSOR (VEHICLE SPEED SENSOR 2) CIRCUIT MALFUNCTION —

- **DTC DETECTING CONDITION:**
 - Two consecutive driving cycles with fault
- **TROUBLE SYMPTOM:**
 - No shift or excessive tight corner “braking”

CAUTION:

After repair or replacement of faulty parts, conduct CLEAR MEMORY MODE <Ref. to 2-7 [T3D0].> and INSPECTION MODE <Ref. to 2-7 [T3E0].>

● **WIRING DIAGRAM:**

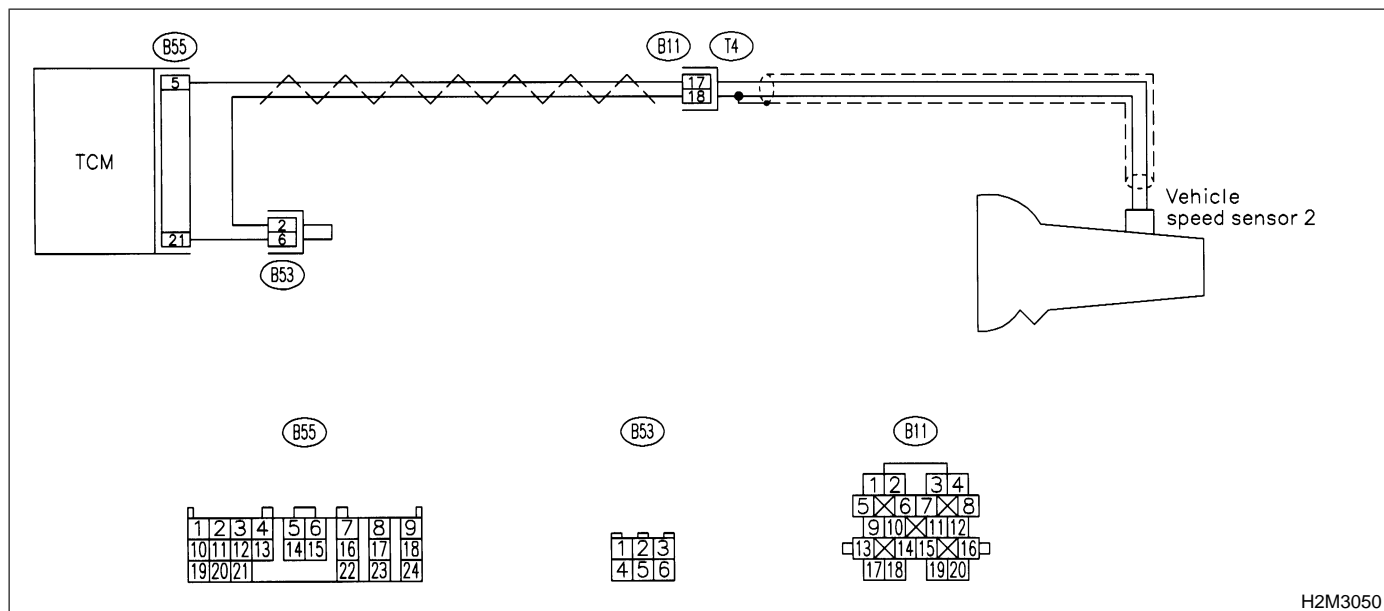

H2M3050

11BA1 : CHECK DTC P0720 ON DISPLAY.

- CHECK** : Does the Subaru Select Monitor or OBD-II general scan tool indicate DTC P0720?
- YES** : Check vehicle speed sensor 2 circuit. <Ref. to 3-2 [T8G0].>
- NO** : It is not necessary to inspect DTC P0720.

BB: DTC P0725 — ENGINE SPEED INPUT CIRCUIT MALFUNCTION —

● **DTC DETECTING CONDITION:**

- Two consecutive driving cycles with fault

● **TROUBLE SYMPTOM:**

- No lock-up (after engine warm-up)
- AT diagnostic indicator light (AT OIL TEMP indicator light) remains on when vehicle speed is "0".

CAUTION:

After repair or replacement of faulty parts, conduct **CLEAR MEMORY MODE** <Ref. to 2-7 [T3D0].> and **INSPECTION MODE** <Ref. to 2-7 [T3E0].>.

● **WIRING DIAGRAM:**

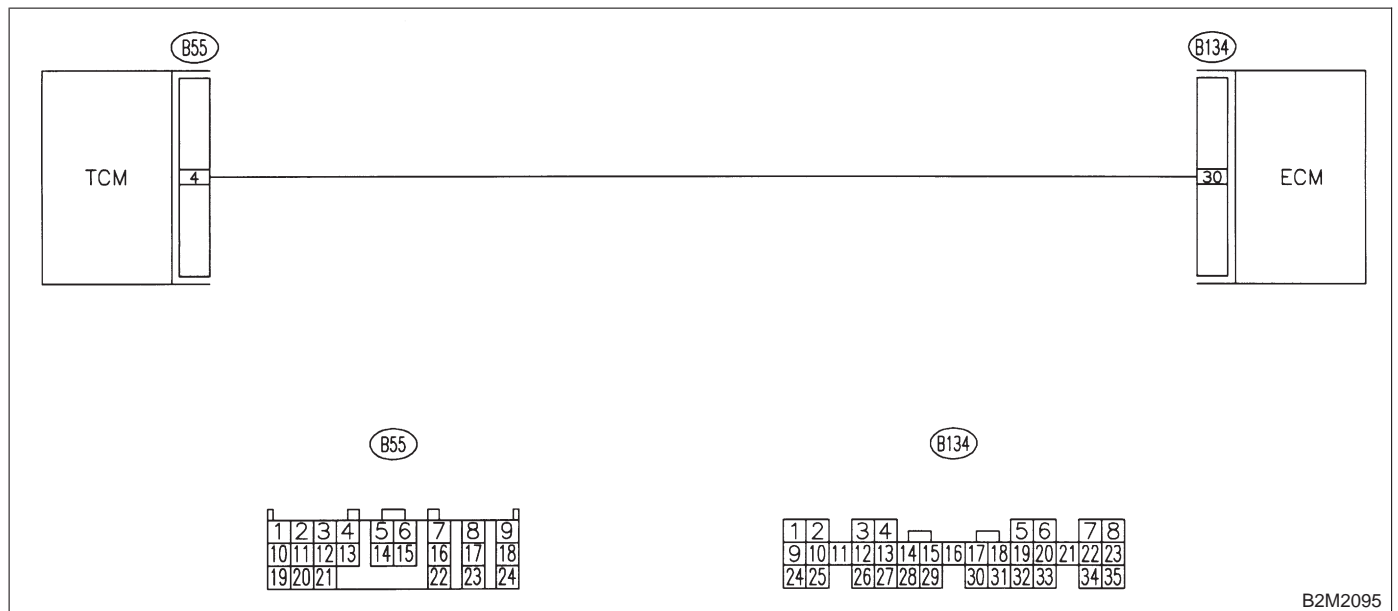

B2M2095

11BB1 : CHECK DTC P0725 ON DISPLAY.

CHECK : Does the Subaru Select Monitor or OBD-II general scan tool indicate DTC P0725?

YES : Check engine speed input signal circuit. <Ref. to 3-2 [T8C0].>

NO : It is not necessary to inspect DTC P0725.

BC: DTC P0731 — GEAR 1 INCORRECT RATIO —**NOTE:**

For the diagnostic procedure, refer to 2-7 [T11BF0]. <Ref. to 2-7 [T11BF0].>

BD: DTC P0732 — GEAR 2 INCORRECT RATIO —**NOTE:**

For the diagnostic procedure, refer to 2-7 [T11BF0]. <Ref. to 2-7 [T11BF0].>

BE: DTC P0733 — GEAR 3 INCORRECT RATIO —**NOTE:**

For the diagnostic procedure, refer to 2-7 [T11BF0]. <Ref. to 2-7 [T11BF0].>

BF: DTC P0734 — GEAR 4 INCORRECT RATIO —**● DTC DETECTING CONDITION:**

- Two consecutive driving cycles with fault

● TROUBLE SYMPTOM:

- Shift point too high or too low; engine brake not effected in “3” range; excessive shift shock; excessive tight corner “braking”

CAUTION:

After repair or replacement of faulty parts, conduct CLEAR MEMORY MODE <Ref. to 2-7 [T3D0].> and INSPECTION MODE <Ref. to 2-7 [T3E0].>.

2-7 [T11BF1]

ON-BOARD DIAGNOSTICS II SYSTEM

11. Diagnostics Chart with Trouble Code for Except 2200 cc California Spec. Vehicles

● WIRING DIAGRAM:

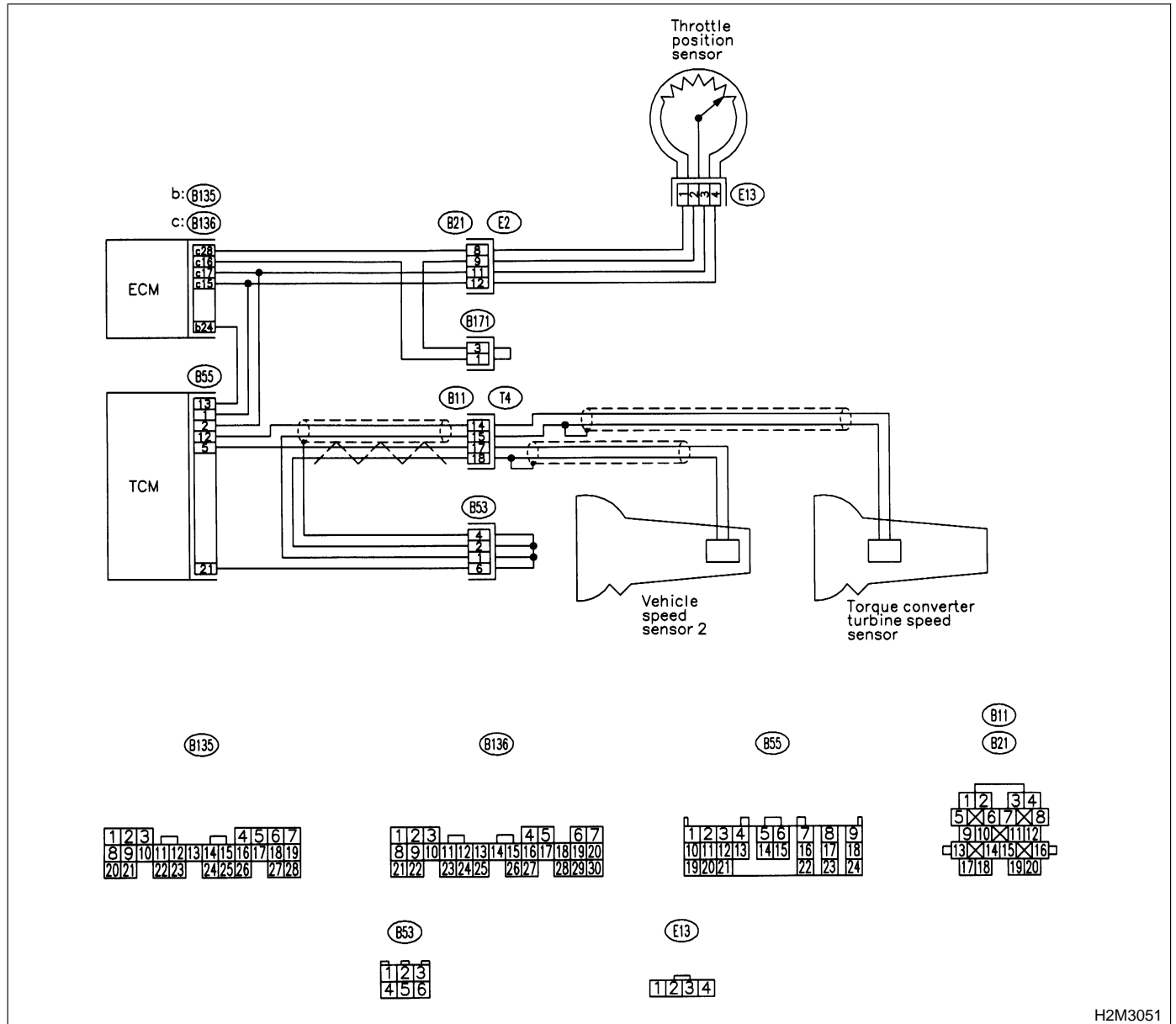

H2M3051

11BF1 : CHECK ANY OTHER DTC ON DISPLAY.

- CHECK** : *Is there any other DTC on display?*
- YES** : Inspect relevant DTC using "11. Diagnostics Chart with Trouble Code for Except 2200 cc California Spec. Vehicles". <Ref. to 2-7 [T11A0].>
- NO** : Go to step **11BF2**.

11BF2 : CHECK THROTTLE POSITION SENSOR CIRCUIT.

- Check throttle position sensor circuit. <Ref. to 3-2 [T8F0].>
- CHECK** : *Is there any trouble in throttle position sensor circuit?*
- YES** : Repair or replace throttle position sensor circuit.
- NO** : Go to step **11BF3**.

11BF3 : CHECK VEHICLE SPEED SENSOR 2 CIRCUIT.

Check vehicle speed sensor 2 circuit. <Ref. to 3-2 [T8G0].>

- CHECK** : *Is there any trouble in vehicle speed sensor 2 circuit?*
- YES** : Repair or replace vehicle speed sensor 2 circuit.
- NO** : Go to step **11BF4**.

11BF4 : CHECK TORQUE CONVERTER TURBINE SPEED SENSOR CIRCUIT.

Check torque converter turbine speed sensor circuit. <Ref. to 3-2 [T8H0].>

- CHECK** : *Is there any trouble in torque converter turbine speed sensor circuit?*
- YES** : Repair or replace torque converter turbine speed sensor circuit.
- NO** : Go to step **11BF5**.

11BF5 : CHECK POOR CONTACT.

Check poor contact in TCM connector. <Ref. to FOREWORD [T3C1].>

- CHECK** : *Is there poor contact in TCM connector?*
- YES** : Repair poor contact in TCM connector.
- NO** : Go to step **11BF6**.

11BF6 : CHECK MECHANICAL TROUBLE.

Check mechanical trouble in automatic transmission.

- CHECK** : *Is there any mechanical trouble in automatic transmission?*
- YES** : Repair or replace automatic transmission. <Ref. to 3-2 [T1000].>
- NO** : Replace TCM. <Ref. to 3-2 [W22A0].>

2-7 [T11BF6]

ON-BOARD DIAGNOSTICS II SYSTEM

11. Diagnostics Chart with Trouble Code for Except 2200 cc California Spec. Vehicles

MEMO:

BG: DTC P0740 — TORQUE CONVERTER CLUTCH SYSTEM MALFUNCTION

• DTC DETECTING CONDITION:

- Two consecutive driving cycles with fault

• TROUBLE SYMPTOM:

- No lock-up (after engine warm-up)
- No shift or excessive tight corner "braking"

CAUTION:

After repair or replacement of faulty parts, conduct CLEAR MEMORY MODE <Ref. to 2-7 [T3D0].> and INSPECTION MODE <Ref. to 2-7 [T3E0].>

• WIRING DIAGRAM:

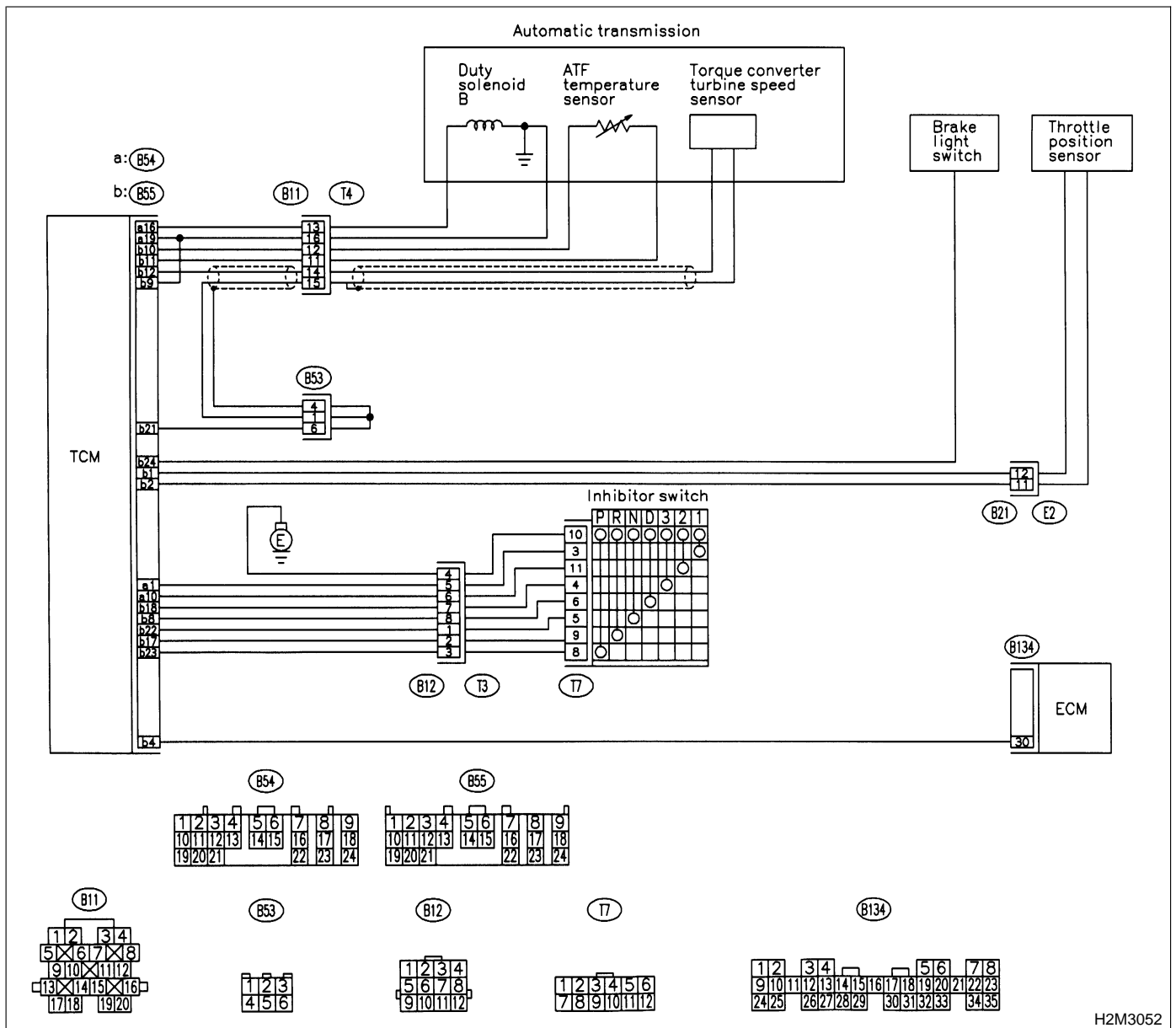

H2M3052

11BG1 : CHECK ANY OTHER DTC ON DISPLAY.

- CHECK** : *Is there any other DTC on display?*
- YES** : Inspect the relevant DTC using "11. Diagnostics Chart with Trouble Code for Except 2200 cc California Spec. Vehicles". <Ref. to 2-7 [T11A0].>
- NO** : Go to step **11BG2**.

11BG2 : CHECK DUTY SOLENOID B CIRCUIT.

Check duty solenoid B circuit. <Ref. to 3-2 [T8Q0].>

- CHECK** : *Is there any trouble in duty solenoid B circuit?*
- YES** : Repair or replace duty solenoid B circuit.
- NO** : Go to step **11BG3**.

11BG3 : CHECK THROTTLE POSITION SENSOR CIRCUIT.

Check throttle position sensor circuit. <Ref. to 3-2 [T8F0].>

- CHECK** : *Is there any trouble in throttle position sensor circuit?*
- YES** : Repair or replace throttle position sensor circuit.
- NO** : Go to step **11BG4**.

11BG4 : CHECK TORQUE CONVERTER TURBINE SPEED SENSOR CIRCUIT.

Check torque converter turbine speed sensor circuit. <Ref. to 3-2 [T8H0].>

- CHECK** : *Is there any trouble in torque converter turbine speed sensor circuit?*
- YES** : Repair or replace torque converter turbine speed sensor circuit.
- NO** : Go to step **11BG5**.

11BG5 : CHECK INHIBITOR SWITCH CIRCUIT.

Check inhibitor switch circuit. <Ref. to 2-7 [T11AX0].>

- CHECK** : *Is there any trouble in inhibitor switch circuit?*
- YES** : Repair or replace inhibitor switch circuit.
- NO** : Go to step **11BG6**.

11BG6 : CHECK BRAKE LIGHT SWITCH CIRCUIT.

Check brake light switch circuit. <Ref. to 2-7 [T11AW0].>

- CHECK** : *Is there any trouble in brake light switch circuit?*
- YES** : Repair or replace brake light switch circuit.
- NO** : Go to step **11BG7**.

11BG7 : CHECK ATF TEMPERATURE SENSOR CIRCUIT.

Check ATF temperature sensor circuit. <Ref. to 3-2 [T8E0].>

- CHECK** : *Is there any trouble in ATF temperature sensor circuit?*
- YES** : Repair or replace ATF temperature sensor circuit.
- NO** : Go to step **11BG8**.

11BG8 : CHECK POOR CONTACT.

Check poor contact in TCM connector. <Ref. to FOREWORD [T3C1].>

- CHECK** : *Is there poor contact in TCM connector?*
- YES** : Repair poor contact in TCM connector.
- NO** : Go to step **11BG9**.

11BG9 : CHECK MECHANICAL TROUBLE.

Check mechanical trouble in automatic transmission.

- CHECK** : *Is there any mechanical trouble in automatic transmission?*
- YES** : Repair or replace automatic transmission. <Ref. to 3-2 [T1000].>
- NO** : Replace TCM. <Ref. to 3-2 [W22A0].>

BH: DTC P0743 — TORQUE CONVERTER CLUTCH SYSTEM (DUTY SOLENOID B) ELECTRICAL —

- **DTC DETECTING CONDITION:**
 - Two consecutive driving cycles with fault
- **TROUBLE SYMPTOM:**
 - No lock-up (after engine warm-up)

CAUTION:

After repair or replacement of faulty parts, conduct CLEAR MEMORY MODE <Ref. to 2-7 [T3D0].> and INSPECTION MODE <Ref. to 2-7 [T3E0].>

● **WIRING DIAGRAM:**

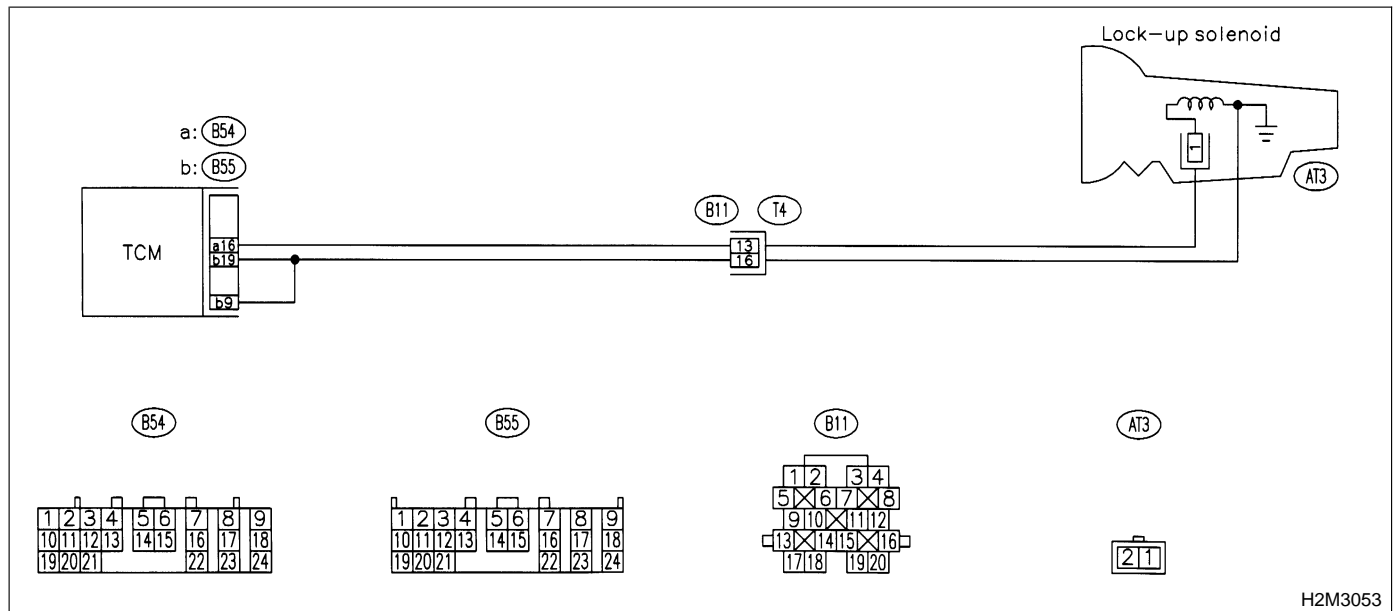

11BH1 : CHECK DTC P0743 ON DISPLAY.

- CHECK** : Does the Subaru Select Monitor or OBD-II general scan tool indicate DTC P0743?
- YES** : Check duty solenoid B circuit. <Ref. to 3-2 [T8Q0].>
- NO** : It is not necessary to inspect DTC P0743.

BI: DTC P0748 — PRESSURE CONTROL SOLENOID (DUTY SOLENOID A) ELECTRICAL —

- **DTC DETECTING CONDITION:**
 - Two consecutive driving cycles with fault
- **TROUBLE SYMPTOM:**
 - Excessive shift shock

CAUTION:

After repair or replacement of faulty parts, conduct **CLEAR MEMORY MODE** <Ref. to 2-7 [T3D0].> and **INSPECTION MODE** <Ref. to 2-7 [T3E0].>

● **WIRING DIAGRAM:**

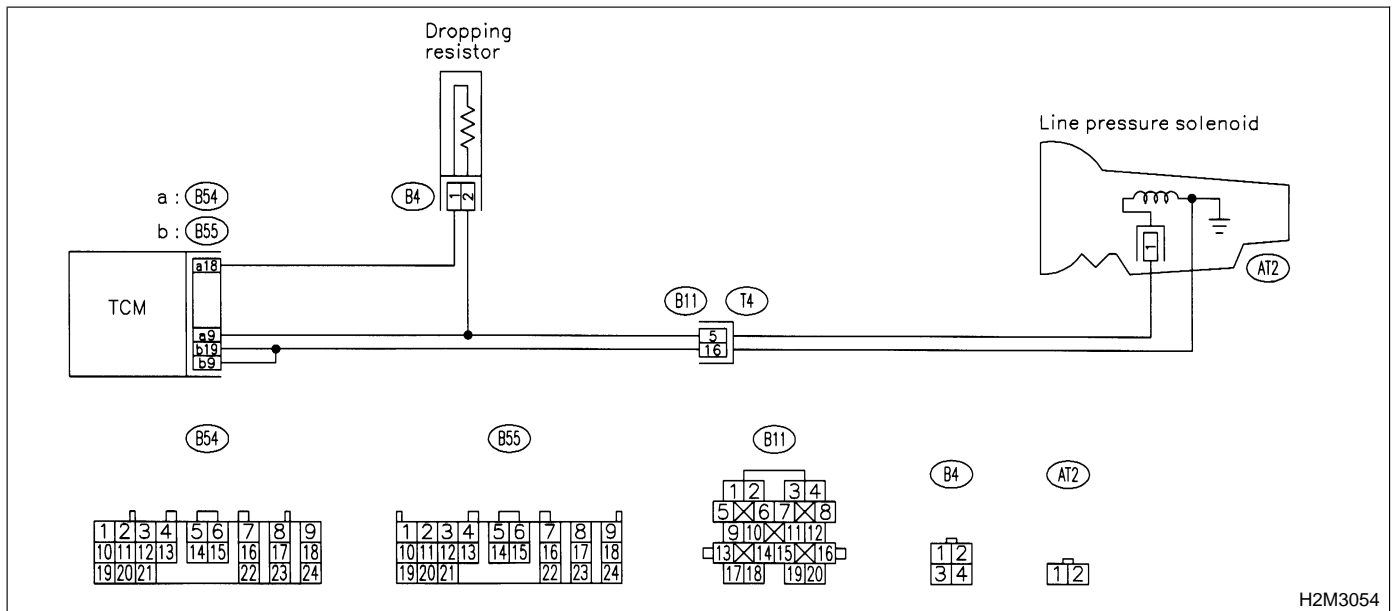

H2M3054

11B11 : CHECK DTC P0748 ON DISPLAY.

- CHECK** : Does the Subaru Select Monitor or OBD-II general scan tool indicate DTC P0748?
- YES** : Check duty solenoid A circuit. <Ref. to 3-2 [T800].>
- NO** : It is not necessary to inspect DTC P0748.

BJ: DTC P0753 — SHIFT SOLENOID A (SHIFT SOLENOID 1) ELECTRICAL —

- **DTC DETECTING CONDITION:**
 - Two consecutive driving cycles with fault
- **TROUBLE SYMPTOM:**
 - No shift

CAUTION:

After repair or replacement of faulty parts, conduct CLEAR MEMORY MODE <Ref. to 2-7 [T3D0].> and INSPECTION MODE <Ref. to 2-7 [T3E0].>

● **WIRING DIAGRAM:**

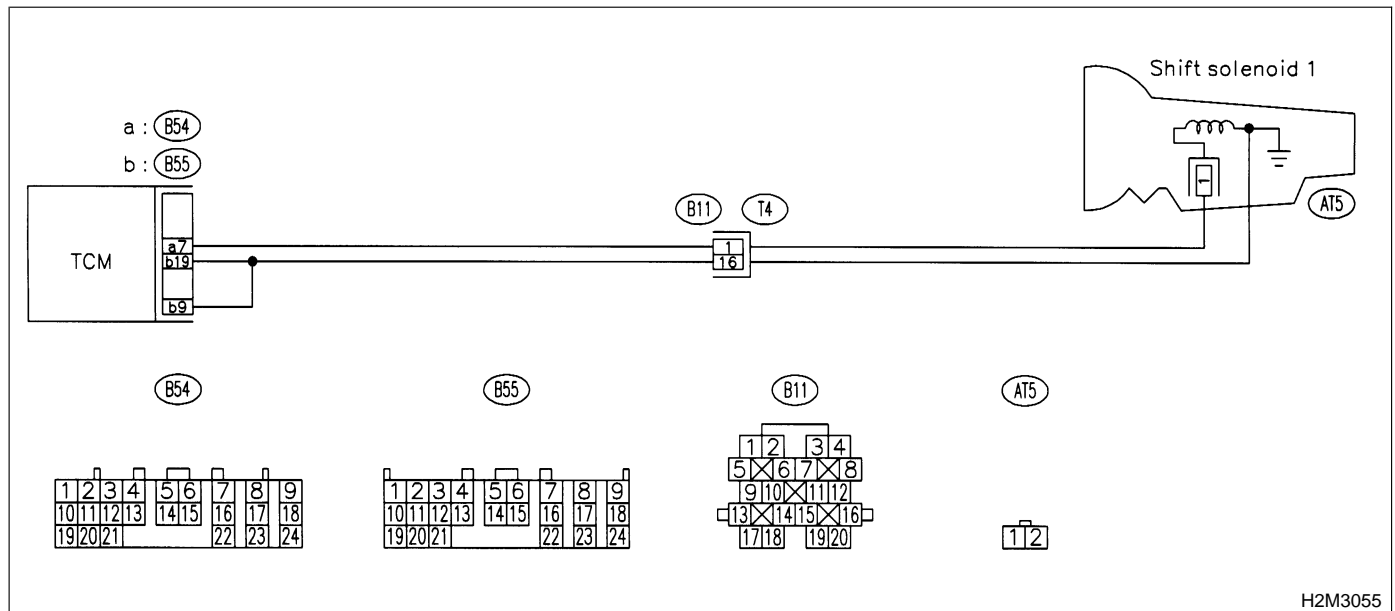

11BJ1 : CHECK DTC P0753 ON DISPLAY.

- CHECK** : Does the Subaru Select Monitor or OBD-II general scan tool indicate DTC P0753?
- YES** : Check shift solenoid 1 circuit. <Ref. to 3-2 [T8K0].>
- NO** : It is not necessary to inspect DTC P0753.

BK: DTC P0758 — SHIFT SOLENOID B (SHIFT SOLENOID 2) ELECTRICAL —

- **DTC DETECTING CONDITION:**
 - Two consecutive driving cycles with fault
- **TROUBLE SYMPTOM:**
 - No shift

CAUTION:

After repair or replacement of faulty parts, conduct CLEAR MEMORY MODE <Ref. to 2-7 [T3D0].> and INSPECTION MODE <Ref. to 2-7 [T3E0].>

● **WIRING DIAGRAM:**

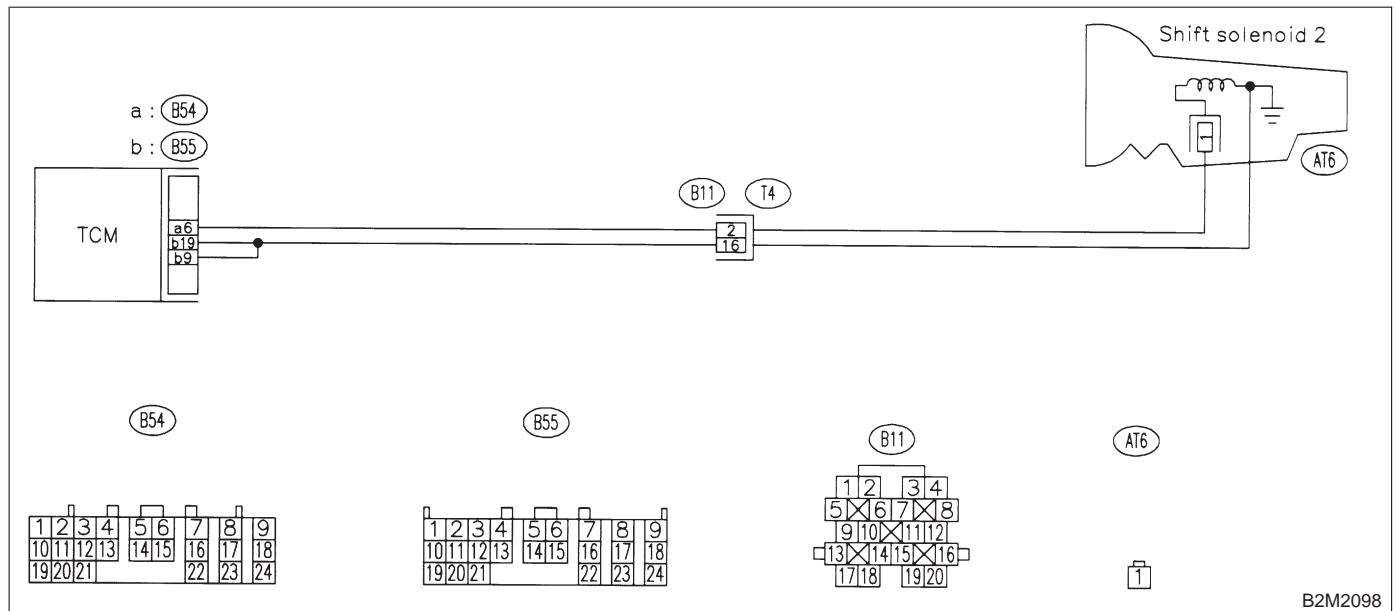

B2M2098

11BK1 : CHECK DTC P0758 ON DISPLAY.

- CHECK** : Does the Subaru Select Monitor or OBD-II general scan tool indicate DTC P0758?
- YES** : Check shift solenoid 2 circuit. <Ref. to 3-2 [T8L0].>
- NO** : It is not necessary to inspect DTC P0758.

BL: DTC P1100 — STARTER SWITCH CIRCUIT LOW INPUT —

- **DTC DETECTING CONDITION:**
 - Two consecutive driving cycles with fault
- **TROUBLE SYMPTOM:**
 - Failure of engine to start

CAUTION:

After repair or replacement of faulty parts, conduct **CLEAR MEMORY MODE** <Ref. to 2-7 [T3D0].> and **INSPECTION MODE** <Ref. to 2-7 [T3E0].>

● **WIRING DIAGRAM:**

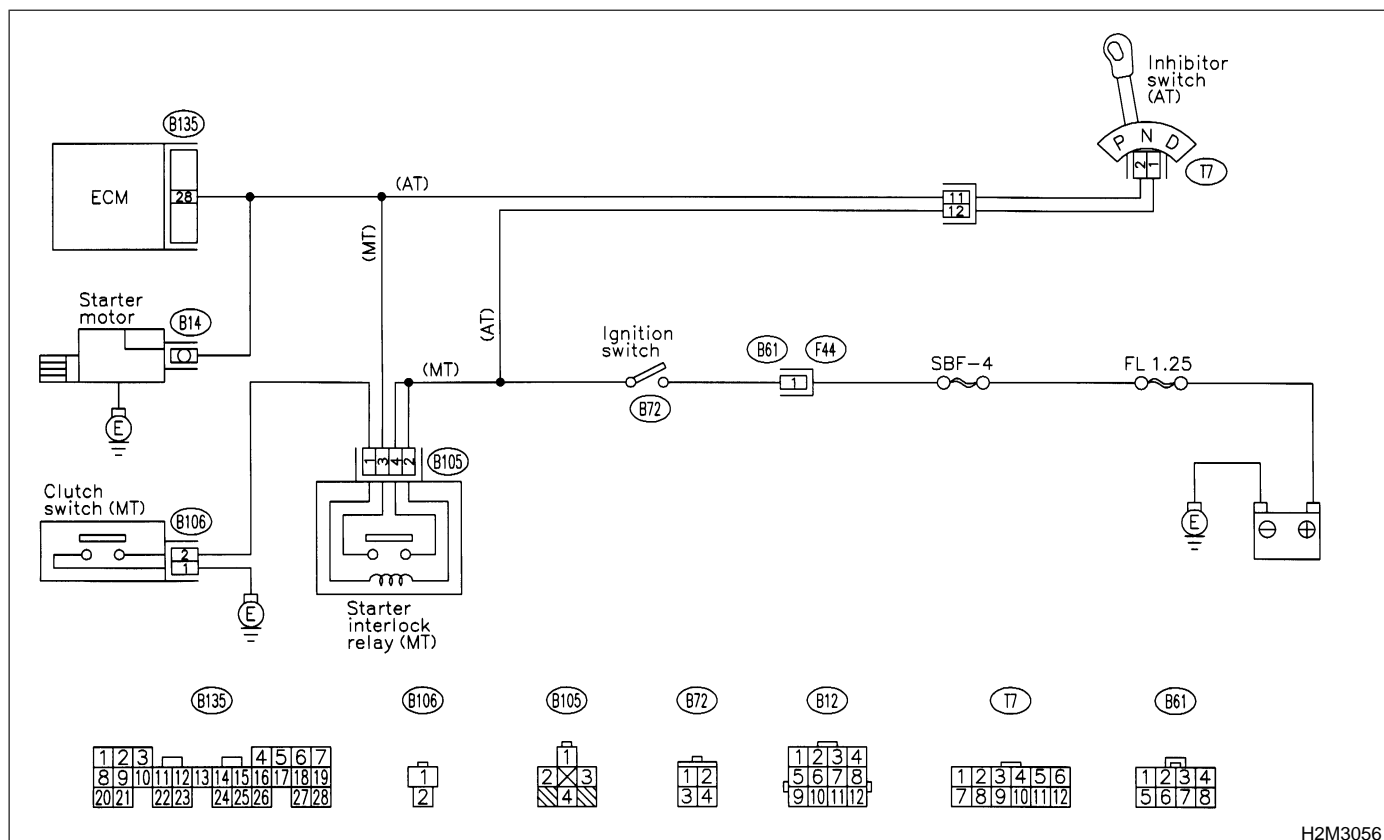

H2M3056

11BL1 : CHECK OPERATION OF STARTER MOTOR.

NOTE:

- On AT vehicles, place the inhibitor switch in the "P" or "N" position.
- On MT vehicles, depress the clutch pedal.

CHECK : *Does starter motor operate when ignition switch to "ST"?*

YES : Repair harness and connector.

NOTE:

In this case, repair the following:

- Open or ground short circuit in harness between ECM and starter motor connector.
- Poor contact in ECM connector.

NO : Check starter motor circuit. <Ref. to 2-7 [T8B0].>

BM: DTC P1101 — NEUTRAL POSITION SWITCH CIRCUIT LOW INPUT [MT VEHICLES] —

- **DTC DETECTING CONDITION:**
 - Two consecutive driving cycles with fault
- **TROUBLE SYMPTOM:**
 - Erroneous idling

CAUTION:

After repair or replacement of faulty parts, conduct CLEAR MEMORY MODE <Ref. to 2-7 [T3D0].> and INSPECTION MODE <Ref. to 2-7 [T3E0].>

● **WIRING DIAGRAM:**

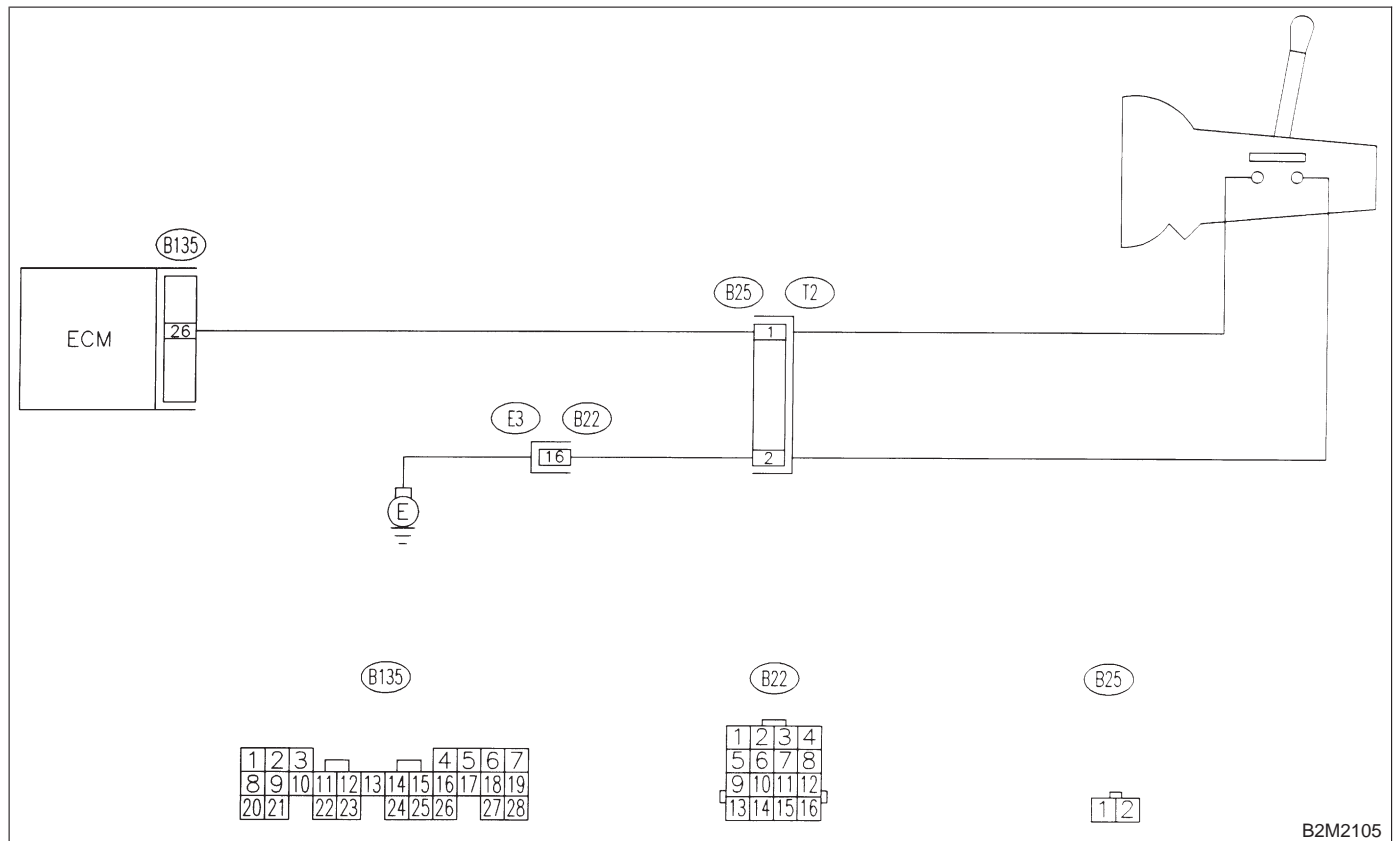

B2M2105

2-7 [T11BM1]

ON-BOARD DIAGNOSTICS II SYSTEM

11. Diagnostics Chart with Trouble Code for Except 2200 cc California Spec. Vehicles

11BM1 : CHECK INPUT SIGNAL FOR ECM.

- 1) Turn ignition switch to ON.
- 2) Measure voltage between ECM and chassis ground.

Connector & terminal

(B135) No. 26 (+) — Chassis ground (-):

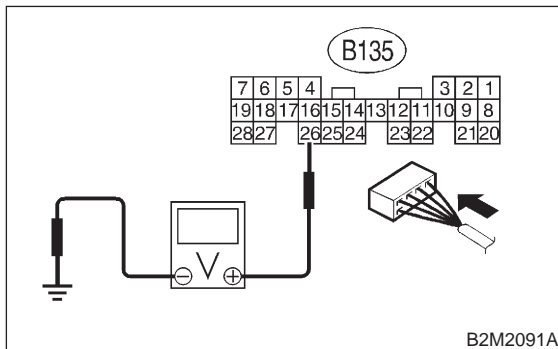

- CHECK** : *Is the voltage more than 10 V in neutral position?*
- YES** : Go to step 11BM2.
- NO** : Go to step 11BM4.

11BM2 : CHECK INPUT SIGNAL FOR ECM.

Measure voltage between ECM and chassis ground.

Connector & terminal

(B135) No. 26 (+) — Chassis ground (-):

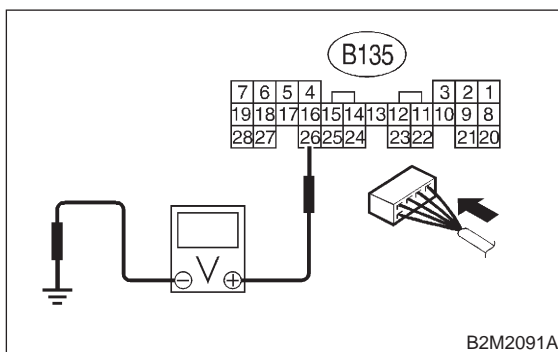

- CHECK** : *Is the voltage less than 1 V in other positions?*
- YES** : Go to step 11BM3.
- NO** : Go to step 11BM4.

11BM3 : CHECK POOR CONTACT.

Check poor contact in ECM connector. <Ref. to FOREWORD [T3C1].>

- CHECK** : *Is there poor contact in ECM connector?*
- YES** : Repair poor contact in ECM connector.
- NO** : Contact with SOA service.

NOTE:

Inspection by DTM is required, because probable cause is deterioration of multiple parts.

11BM4 : CHECK NEUTRAL POSITION SWITCH.

- 1) Turn ignition switch to OFF.
- 2) Disconnect connector from transmission harness.
- 3) Measure resistance between transmission harness and connector terminals.

Connector & terminal

(T2) No. 1 — No. 2:

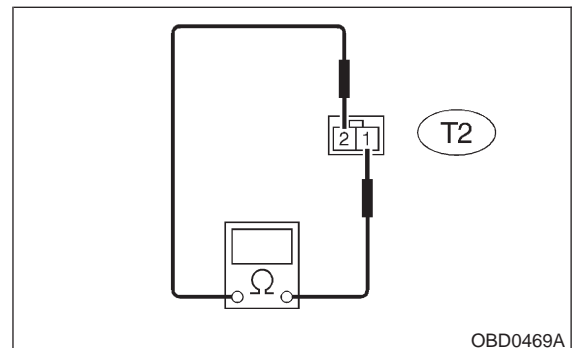

- CHECK** : *Is the resistance more than 1 MΩ in neutral position?*
- YES** : Go to step 11BM5.
- NO** : Repair short circuit in transmission harness or replace neutral position switch.

11BM5 : CHECK HARNESS BETWEEN ECM AND NEUTRAL POSITION SWITCH CONNECTOR.

Measure resistance between ECM and chassis ground.

Connector & terminal

(B135) No. 26 — Chassis ground:

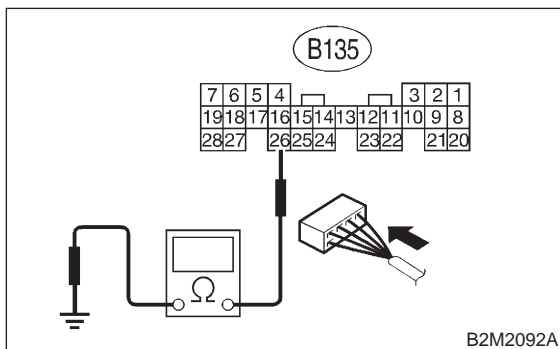

- CHECK** : *Is the resistance less than 10 Ω?*
- YES** : Repair ground short circuit in harness between ECM and transmission harness connector.
- NO** : Go to step **11BM6**.

11BM6 : CHECK POOR CONTACT.

Check poor contact in transmission harness connector. <Ref. to FOREWORD [T3C1].>

- CHECK** : *Is there poor contact in transmission harness connector?*
- YES** : Repair poor contact in transmission harness connector.
- NO** : Contact with SOA service.

NOTE:

Inspection by DTM is required, because probable cause is deterioration of multiple parts.

MEMO:

BN: DTC P1101 — NEUTRAL POSITION SWITCH CIRCUIT HIGH INPUT [AT VEHICLES] —

- **DTC DETECTING CONDITION:**
 - Two consecutive driving cycles with fault
- **TROUBLE SYMPTOM:**
 - Erroneous idling

CAUTION:

After repair or replacement of faulty parts, conduct CLEAR MEMORY MODE <Ref. to 2-7 [T3D0].> and INSPECTION MODE <Ref. to 2-7 [T3E0].>

● **WIRING DIAGRAM:**

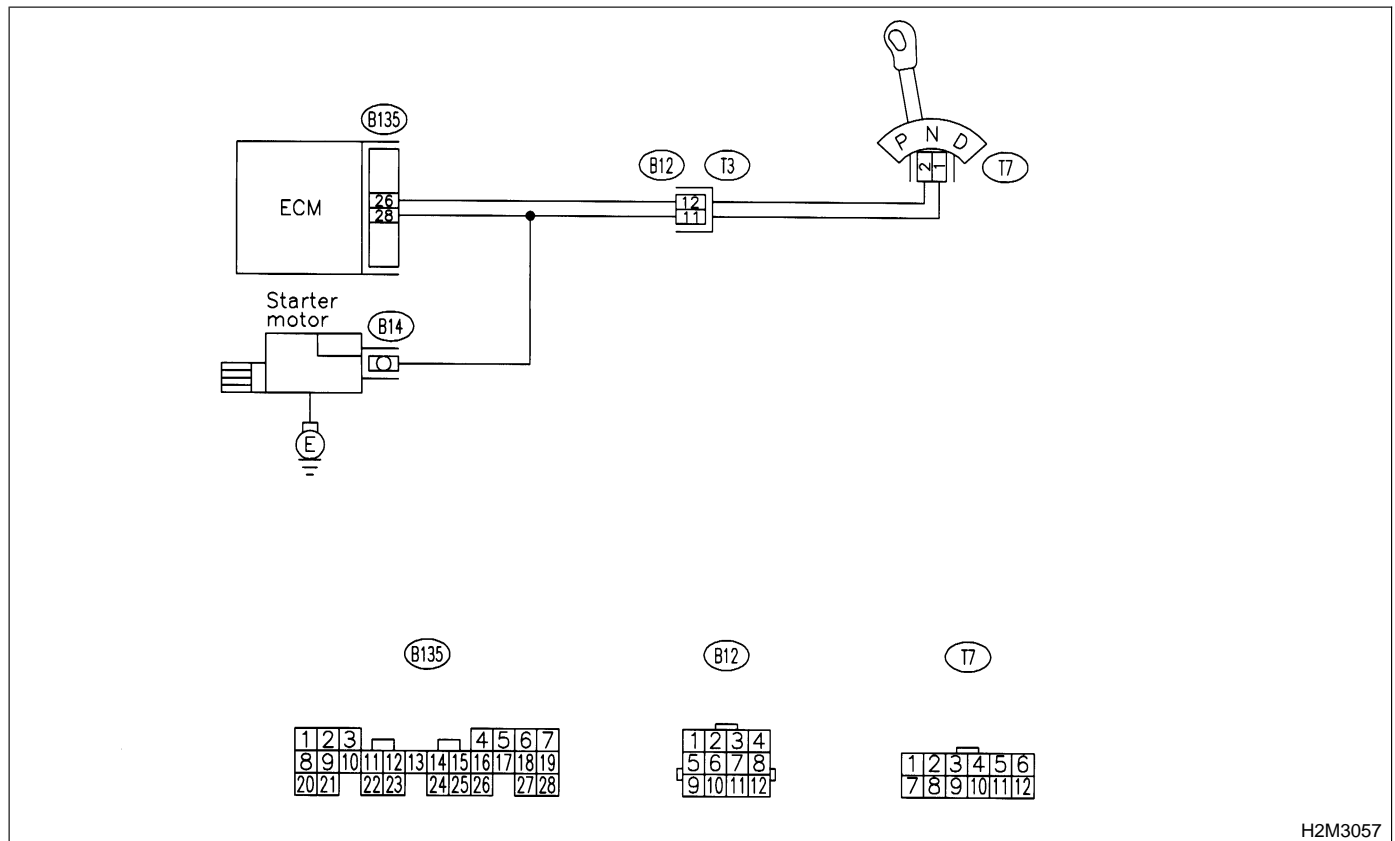

H2M3057

11BN1 : CHECK DTC P0705 ON DISPLAY.

- CHECK** : Does the Subaru Select Monitor or OBD-II general scan tool indicate DTC P0705?
- YES** : Inspect DTC P0705 using "11. Diagnostics Chart with Trouble Code for Except 2200 cc California Spec. Vehicles". <Ref. to 2-7 [T11A0].>
- NO** : Go to step 11BN2.

11BN2 : CHECK INPUT SIGNAL FOR ECM.

- 1) Turn ignition switch to ON.
- 2) Measure voltage between ECM and chassis ground in selector lever "N" and "P" positions.

Connector & terminal

(B135) No. 26 (+) — Chassis ground (-):

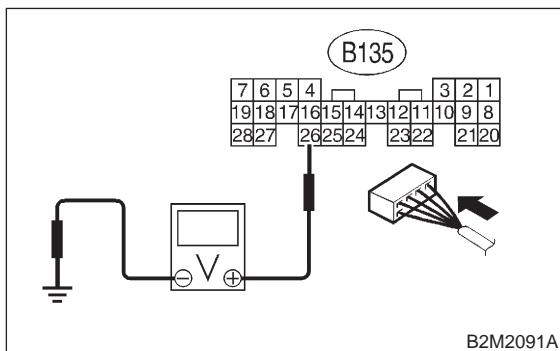

- CHECK** : Is the voltage less than 1 V?
- YES** : Go to step 11BN3.
- NO** : Go to step 11BN5.

11BN3 : CHECK INPUT SIGNAL FOR ECM.

Measure voltage between ECM and chassis ground in selector lever except for "N" and "P" positions.

Connector & terminal

(B135) No. 26 (+) — Chassis ground (-):

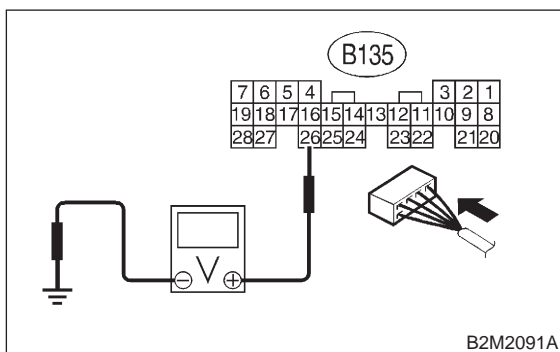

- CHECK** : Is the voltage between 4.5 and 5.5 V?
- YES** : Go to step 11BN4.
- NO** : Go to step 11BN5.

11BN4 : CHECK POOR CONTACT.

Check poor contact in ECM connector. <Ref. to FOREWORD [T3C1].>

- CHECK** : Is there poor contact in ECM connector?
- YES** : Repair poor contact in ECM connector.
- NO** : Contact with SOA service.

NOTE:

Inspection by DTM is required, because probable cause is deterioration of multiple parts.

11BN5 : CHECK INPUT SIGNAL FOR ECM.

Measure voltage between ECM and chassis ground.

Connector & terminal

(B135) No. 26 (+) — Chassis ground (-):

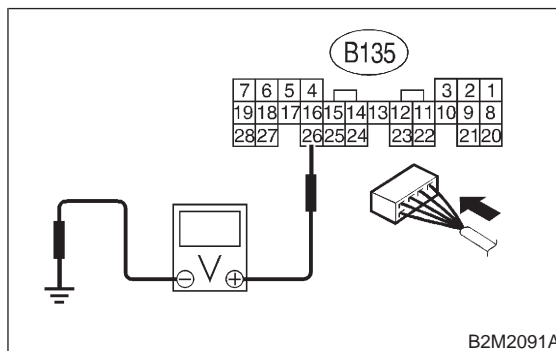

- CHECK** : Is the voltage more than 10 V?
- YES** : Repair battery short circuit in harness between ECM and inhibitor switch connector.
- NO** : Go to step 11BN6.

11BN6 : CHECK HARNESS BETWEEN ECM AND INHIBITOR SWITCH CONNECTOR.

- 1) Turn ignition switch to OFF.
- 2) Disconnect connectors from ECM and inhibitor switch.
- 3) Measure resistance of harness between ECM and inhibitor switch connector.

Connector & terminal

(B135) No. 26 — (T7) No. 2:

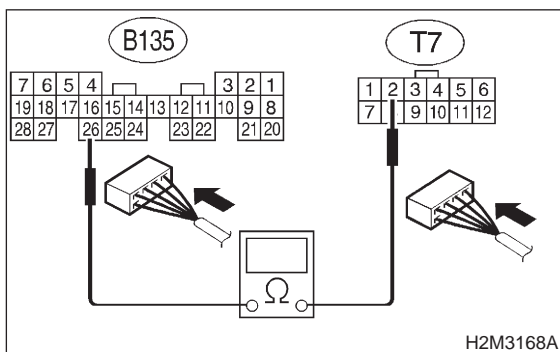

- CHECK** : Is the resistance less than 1 Ω?
- YES** : Go to step 11BN7.
- NO** : Repair harness and connector.

NOTE:

In this case, repair the following:

- Open circuit in harness between ECM and inhibitor switch connector
- Poor contact in coupling connector (B12)
- Poor contact in inhibitor switch connector
- Poor contact in ECM connector

11BN7 : CHECK INHIBITOR SWITCH GROUND LINE.

Measure resistance of harness between inhibitor switch connector and engine ground.

Connector & terminal

(T7) No. 1 — Engine ground:

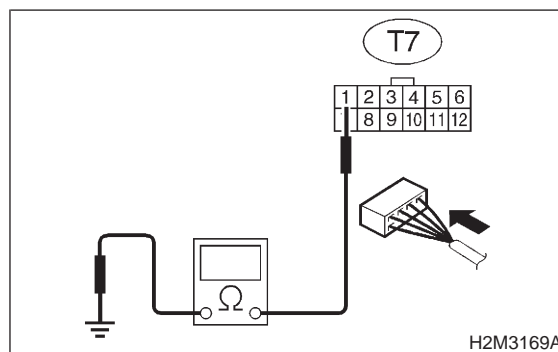

- CHECK** : Is the resistance less than 5 Ω?
- YES** : Go to step 11BN8.
- NO** : Repair open circuit in inhibitor switch ground line.

11BN8 : CHECK INHIBITOR SWITCH.

Measure resistance between inhibitor switch connector receptacle's terminals in selector lever "N" and "P" positions.

Terminals

No. 2 — No. 1:

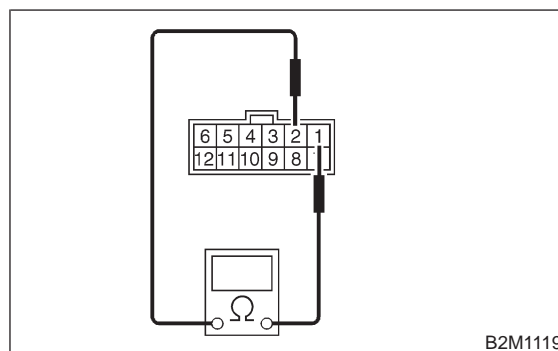

- CHECK** : Is the resistance less than 1 Ω?
- YES** : Go to step 11BN9.
- NO** : Replace inhibitor switch. <Ref. to 3-2 [W2C0].>

11BN9 : CHECK SELECTOR CABLE CONNECTION.

CHECK : *Is there any fault in selector cable connection to inhibitor switch?*

YES : Repair selector cable connection. <Ref. to 3-2 [W2A0].>

NO : Contact with SOA service.

NOTE:

Inspection by DTM is required, because probable cause is deterioration of multiple parts.

BO: DTC P1102 — PRESSURE SOURCES SWITCHING SOLENOID VALVE CIRCUIT LOW INPUT —

- **DTC DETECTING CONDITION:**
 - Two consecutive driving cycles with fault
- **TROUBLE SYMPTOM:**
 - Erroneous idling
 - Failure of engine to start

CAUTION:

After repair or replacement of faulty parts, conduct CLEAR MEMORY MODE <Ref. to 2-7 [T3D0].> and INSPECTION MODE <Ref. to 2-7 [T3E0].>

● **WIRING DIAGRAM:**

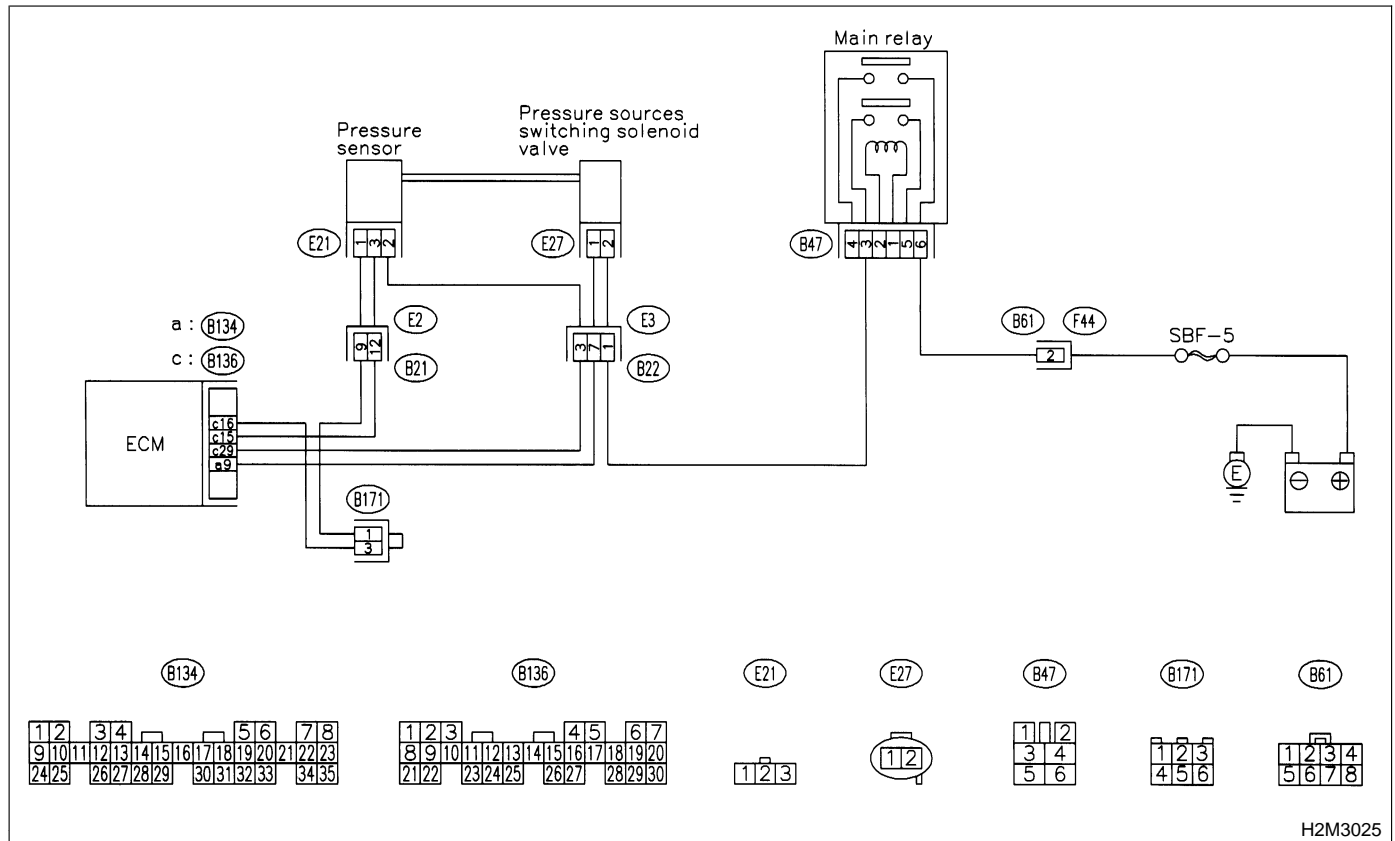

H2M3025

2-7 [T11B01]

ON-BOARD DIAGNOSTICS II SYSTEM

11. Diagnostics Chart with Trouble Code for Except 2200 cc California Spec. Vehicles

11B01 : CHECK OUTPUT SIGNAL FROM ECM.

- 1) Turn ignition switch to ON.
- 2) Measure voltage between ECM and chassis ground.

Connector & terminal

(B134) No. 9 (+) — Chassis ground (-):

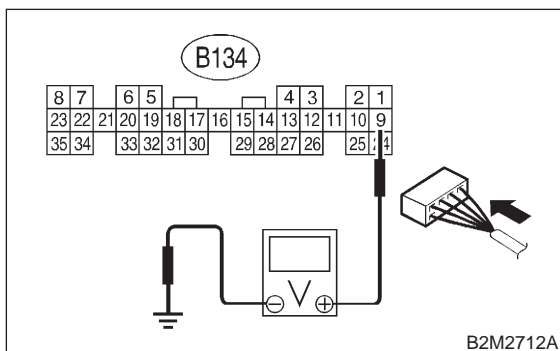

- CHECK** : Is the voltage more than 10 V?
YES : Go to step 11B02.
NO : Go to step 11B03.

11B02 : CHECK POOR CONTACT.

Check poor contact in ECM connector. <Ref. to FOREWORD [T3C1].>

- CHECK** : Is there poor contact in ECM connector?
YES : Repair poor contact in ECM connector.
NO : Contact with SOA service.

NOTE:

Inspection by DTM is required, because probable cause is deterioration of multiple parts.

11B03 : CHECK HARNESS BETWEEN ECM AND PRESSURE SOURCES SWITCHING SOLENOID VALVE CONNECTOR.

- 1) Turn ignition switch to OFF.
- 2) Disconnect connector from pressure sources switching solenoid valve and ECM.
- 3) Measure resistance of harness between pressure sources switching solenoid valve connector and engine ground.

Connector & terminal

(E27) No. 1 — Engine ground:

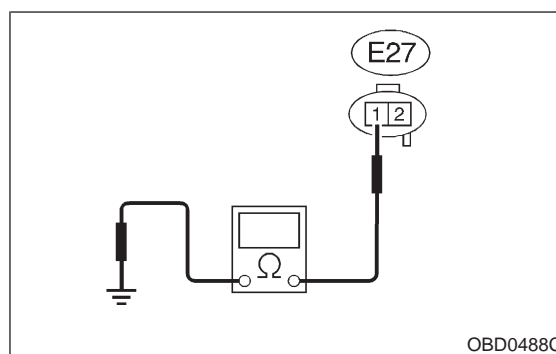

- CHECK** : Is the resistance less than 10 Ω?
YES : Repair ground short circuit in harness between ECM and pressure sources switching solenoid valve connector.
NO : Go to step 11B04.

11B04 : CHECK HARNESS BETWEEN ECM AND PRESSURE SOURCES SWITCHING SOLENOID VALVE CONNECTOR.

Measure resistance of harness between ECM and pressure sources switching solenoid valve connector.

Connector & terminal

(B134) No. 9 — (E27) No. 1:

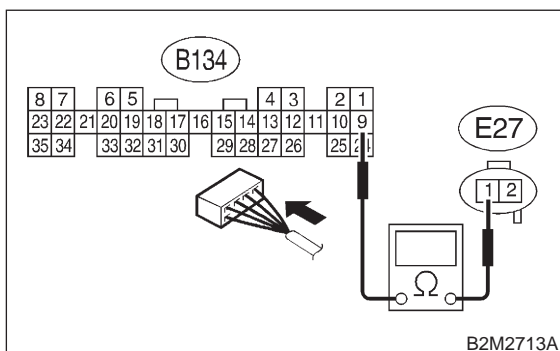

- CHECK** : Is the resistance less than 1 Ω?
- YES** : Go to step 11B05.
- NO** : Repair open circuit in harness between ECM and pressure sources switching solenoid valve connector.

11B05 : CHECK PRESSURE SOURCES SWITCHING SOLENOID VALVE.

Measure resistance between pressure sources switching solenoid valve connector terminals.

Terminals

No. 1 — No. 2:

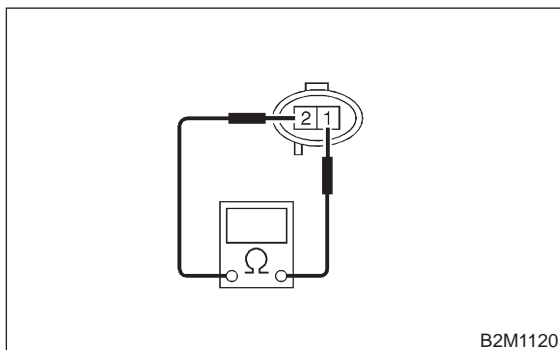

- CHECK** : Is the resistance between 10 and 100 Ω?
- YES** : Go to step 11B06.
- NO** : Replace pressure sources switching solenoid valve. <Ref. to 2-7 [W13A0].>

11B06 : CHECK POWER SUPPLY TO PRESSURE SOURCES SWITCHING SOLENOID VALVE.

- 1) Turn ignition switch to ON.
- 2) Measure voltage between pressure sources switching solenoid valve harness connector and engine ground.

Connector & terminal

(E27) No. 2 (+) — Engine ground (-):

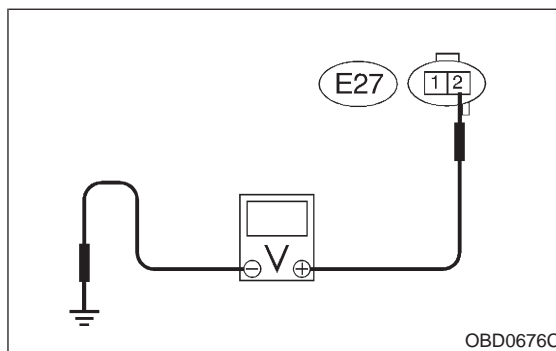

- CHECK** : Is the voltage more than 10 V?
- YES** : Go to step 11B07.
- NO** : Repair open circuit in harness between main relay and pressure sources switching solenoid valve connector.

11B07 : CHECK POOR CONTACT.

Check poor contact in pressure sources switching solenoid valve connector. <Ref. to FOREWORD [T3C1].>

- CHECK** : Is there poor contact in pressure sources switching solenoid valve connector?
- YES** : Repair poor contact in pressure sources switching solenoid valve connector.
- NO** : Contact with SOA service.

NOTE:

Inspection by DTM is required, because probable cause is deterioration of multiple parts.

2-7 [T11B07]

ON-BOARD DIAGNOSTICS II SYSTEM

11. Diagnostics Chart with Trouble Code for Except 2200 cc California Spec. Vehicles

MEMO:

BP: DTC P1103 — ENGINE TORQUE CONTROL SIGNAL 1 CIRCUIT MALFUNCTION —

- **DTC DETECTING CONDITION:**
 - Two consecutive driving cycles with fault
- **TROUBLE SYMPTOM:**
 - Excessive shift shock

CAUTION:

After repair or replacement of faulty parts, conduct **CLEAR MEMORY MODE** <Ref. to 2-7 [T3D0].> and **INSPECTION MODE** <Ref. to 2-7 [T3E0].>

● **WIRING DIAGRAM:**

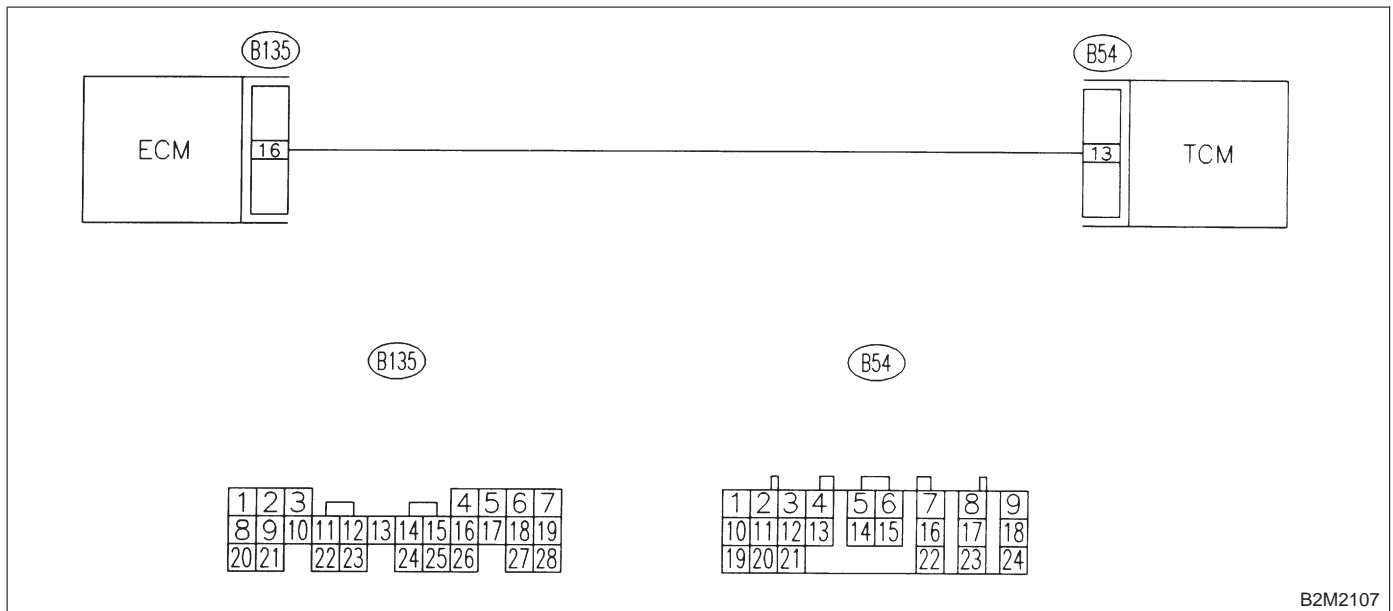

B2M2107

11BP1 : CHECK INPUT SIGNAL FOR ECM.

- 1) Turn ignition switch to ON.
- 2) Measure voltage between ECM and chassis ground.

Connector & terminal
(B135) No. 16 (+) — Chassis ground (-):

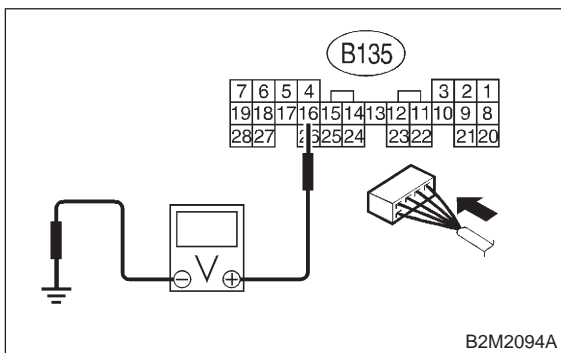

B2M2094A

- CHECK** : Is the voltage more than 4.5 V?
- YES** : Go to step 11BP2.
- NO** : Go to step 11BP4.

11BP2 : CHECK INPUT SIGNAL FOR ECM.

Measure voltage between ECM and chassis ground.

Connector & terminal
(B135) No. 16 (+) — Chassis ground (-):

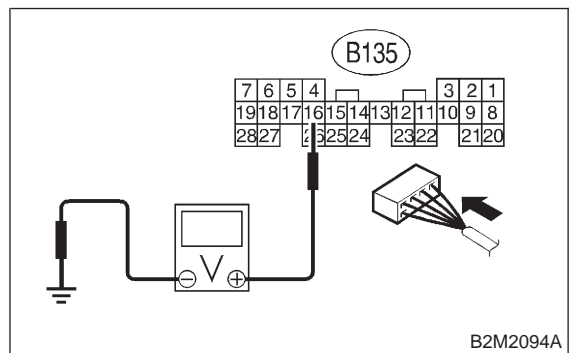

B2M2094A

- CHECK** : Is the voltage more than 10 V?
- YES** : Repair battery short circuit in harness between ECM and TCM connector.
- NO** : Go to step 11BP3.

2-7 [T11BP3]

ON-BOARD DIAGNOSTICS II SYSTEM

11. Diagnostics Chart with Trouble Code for Except 2200 cc California Spec. Vehicles

11BP3 : CHECK POOR CONTACT.

Check poor contact in ECM connector. <Ref. to FOREWORD [T3C1].>

- CHECK** : *Is there poor contact in ECM connector?*
- YES** : Repair poor contact in ECM connector.
- NO** : Replace ECM. <Ref. to 2-7 [W15A0].>

11BP4 : CHECK HARNESS BETWEEN ECM AND TCM CONNECTOR.

- 1) Turn ignition switch to OFF.
- 2) Disconnect connectors from ECM and TCM.
- 3) Measure resistance of harness between ECM and TCM connector.

Connector & terminal

(B135) No. 16 — (B54) No. 13:

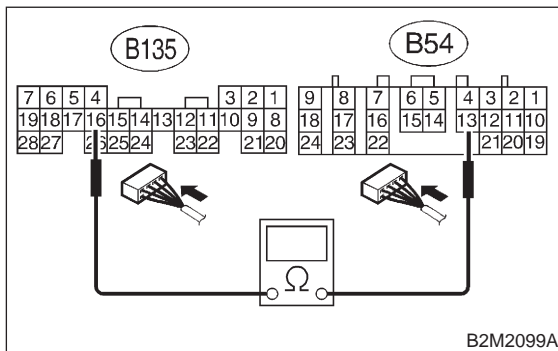

- CHECK** : *Is the resistance less than 1 Ω?*
- YES** : Go to step 11BP5.
- NO** : Repair open circuit in harness between ECM and TCM connector.

11BP5 : CHECK HARNESS BETWEEN ECM AND TCM CONNECTOR.

Measure resistance of harness between ECM and chassis ground.

Connector & terminal

(B135) No. 16 — Chassis ground:

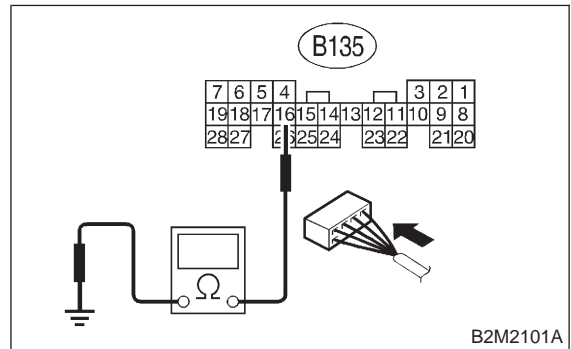

- CHECK** : *Is the resistance less than 10 Ω?*
- YES** : Repair ground short circuit in harness between ECM and TCM connector.
- NO** : Go to step 11BP6.

11BP6 : CHECK POOR CONTACT.

Check poor contact in TCM connector. <Ref. to FOREWORD [T3C1].>

- CHECK** : *Is there poor contact in TCM connector?*
- YES** : Repair poor contact in TCM connector.
- NO** : Replace TCM. <Ref. to 3-2 [W22A0].>

BQ: DTC P1106 — ENGINE TORQUE CONTROL SIGNAL 2 CIRCUIT MALFUNCTION —

- **DTC DETECTING CONDITION:**
 - Two consecutive driving cycles with fault
- **TROUBLE SYMPTOM:**
 - Excessive shift shock

CAUTION:

After repair or replacement of faulty parts, conduct **CLEAR MEMORY MODE** <Ref. to 2-7 [T3D0].> and **INSPECTION MODE** <Ref. to 2-7 [T3E0].>

● **WIRING DIAGRAM:**

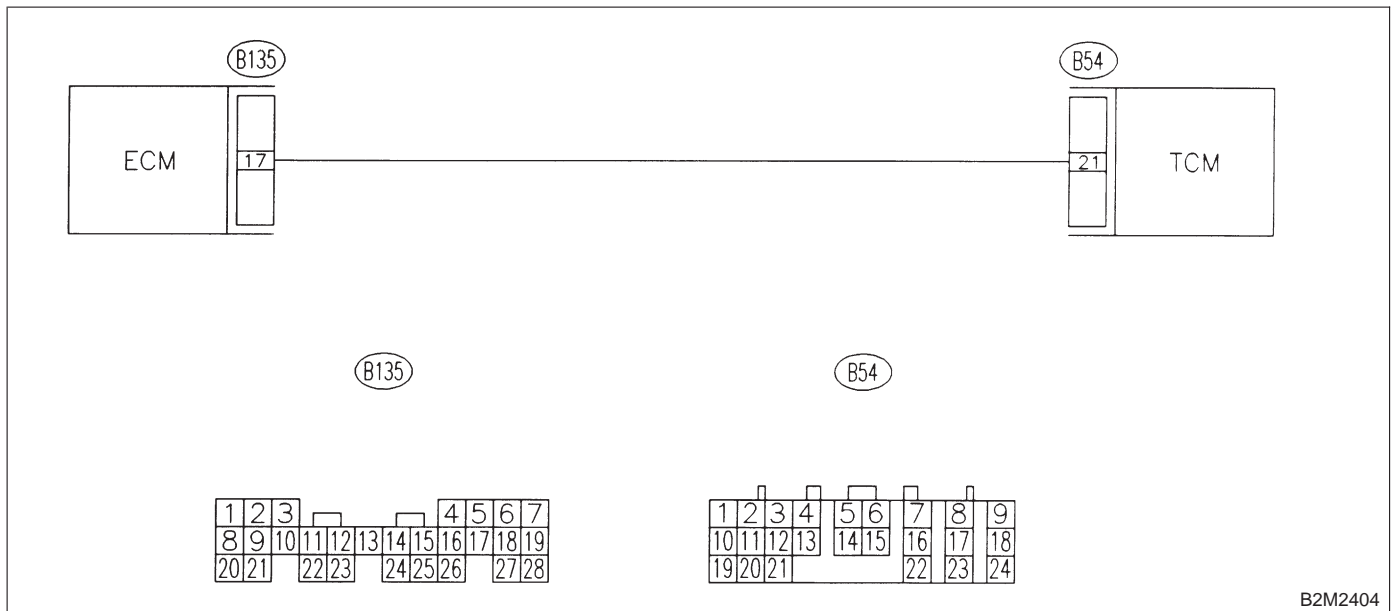

B2M2404

11BQ1 : CHECK INPUT SIGNAL FOR ECM.

- 1) Turn ignition switch to ON.
- 2) Measure voltage between ECM and chassis ground.

Connector & terminal

(B135) No. 17 (+) — Chassis ground (-):

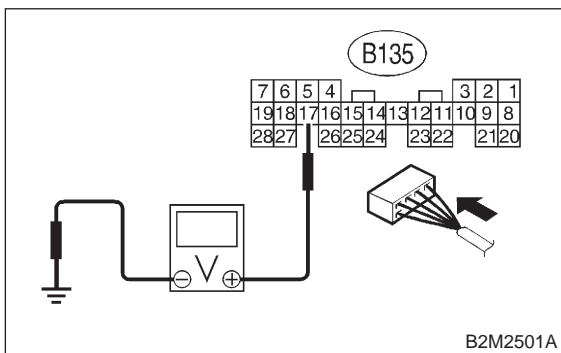

B2M2501A

- CHECK** : Is the voltage more than 4.5 V?
- YES** : Go to step 11BQ2.
- NO** : Go to step 11BQ4.

11BQ2 : CHECK INPUT SIGNAL FOR ECM.

Measure voltage between ECM and chassis ground.

Connector & terminal

(B135) No. 17 (+) — Chassis ground (-):

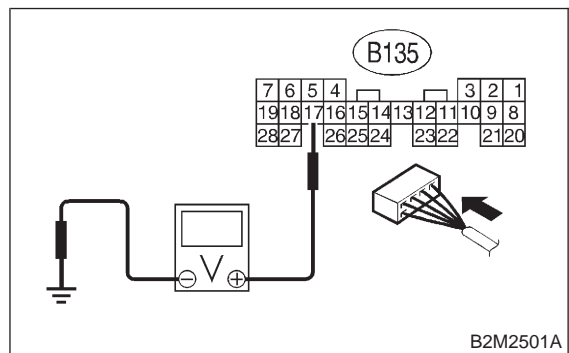

B2M2501A

- CHECK** : Is the voltage more than 10 V?
- YES** : Repair battery short circuit in harness between ECM and TCM connector.
- NO** : Go to step 11BQ3.

2-7 [T11BQ3]

ON-BOARD DIAGNOSTICS II SYSTEM

11. Diagnostics Chart with Trouble Code for Except 2200 cc California Spec. Vehicles

11BQ3 : CHECK POOR CONTACT.

Check poor contact in ECM connector. <Ref. to FOREWORD [T3C1].>

- CHECK** : *Is there poor contact in ECM connector?*
- YES** : Repair poor contact in ECM connector.
- NO** : Replace ECM. <Ref. to 2-7 [W15A0].>

11BQ4 : CHECK HARNESS BETWEEN ECM AND TCM CONNECTOR.

- 1) Turn ignition switch to OFF.
- 2) Disconnect connectors from ECM and TCM.
- 3) Measure resistance of harness between ECM and TCM connector.

Connector & terminal

(B135) No. 17 — (B54) No. 21:

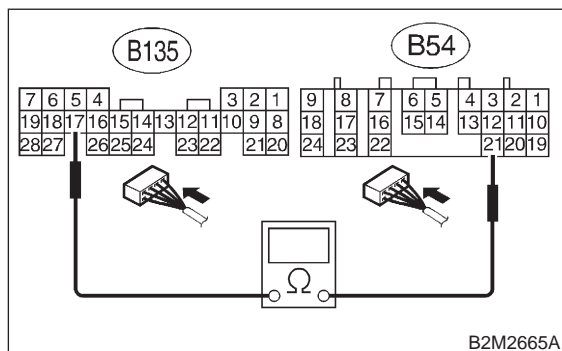

- CHECK** : *Is the resistance less than 1 Ω?*
- YES** : Go to step 11BQ5.
- NO** : Repair open circuit in harness between ECM and TCM connector.

11BQ5 : CHECK HARNESS BETWEEN ECM AND TCM CONNECTOR.

Measure resistance of harness between ECM and chassis ground.

Connector & terminal

(B135) No. 17 — Chassis ground:

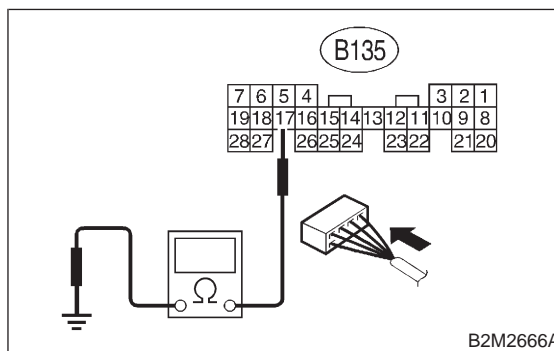

- CHECK** : *Is the resistance less than 10 Ω?*
- YES** : Repair ground short circuit in harness between ECM and TCM connector.
- NO** : Go to step 11BQ6.

11BQ6 : CHECK POOR CONTACT.

Check poor contact in TCM connector. <Ref. to FOREWORD [T3C1].>

- CHECK** : *Is there poor contact in TCM connector?*
- YES** : Repair poor contact in TCM connector.
- NO** : Replace TCM. <Ref. to 3-2 [W22A0].>

BR: DTC P1115 — ENGINE TORQUE CONTROL CUT SIGNAL CIRCUIT HIGH INPUT —

● **DTC DETECTING CONDITION:**

- Two consecutive driving cycles with fault

CAUTION:

After repair or replacement of faulty parts, conduct **CLEAR MEMORY MODE** <Ref. to 2-7 [T3D0].> and **INSPECTION MODE** <Ref. to 2-7 [T3E0].>

● **WIRING DIAGRAM:**

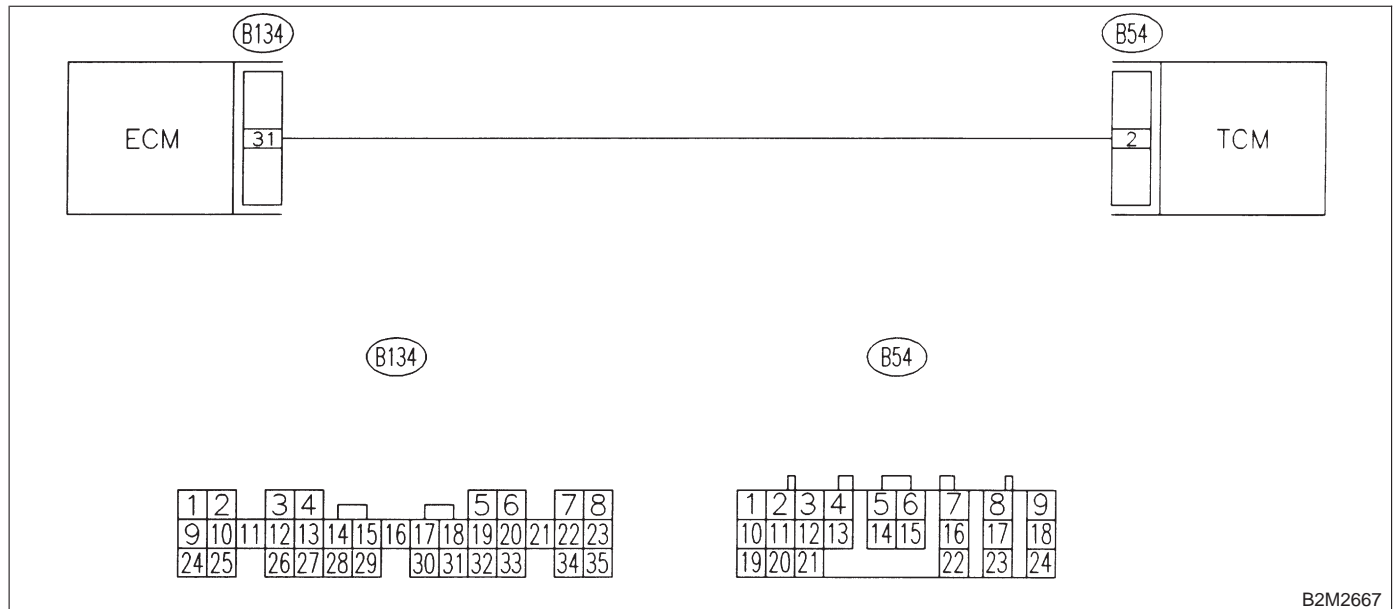

B2M2667

2-7 [T11BR1]

ON-BOARD DIAGNOSTICS II SYSTEM

11. Diagnostics Chart with Trouble Code for Except 2200 cc California Spec. Vehicles

11BR1 : CHECK OUTPUT SIGNAL FROM ECM.

- 1) Start engine, and warm-up the engine.
- 2) Turn ignition switch to OFF.
- 3) Disconnect connector from TCM.
- 4) Turn ignition switch to ON.
- 5) Measure voltage between ECM and chassis ground.

Connector & terminal

(B134) No. 31 (+) — Chassis ground (-):

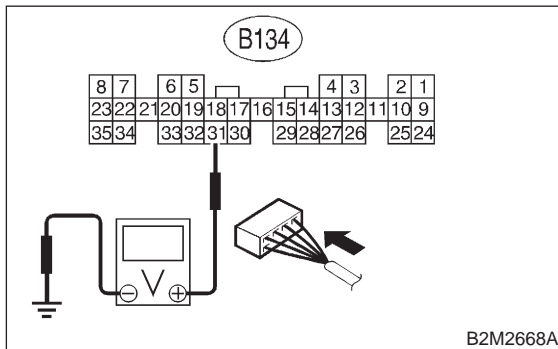

- CHECK** : Is the voltage less than 3 V?
- YES** : Go to step 11BR2.
- NO** : Repair battery short circuit in harness between ECM and TCM connector. After repair, replace ECM. <Ref. to 2-7 [W15A0].>

11BR2 : CHECK HARNESS BETWEEN ECM AND TCM CONNECTOR.

- 1) Turn ignition switch to OFF.
- 2) Measure voltage between ECM and chassis ground.

Connector & terminal

(B134) No. 31 (+) — Chassis ground (-):

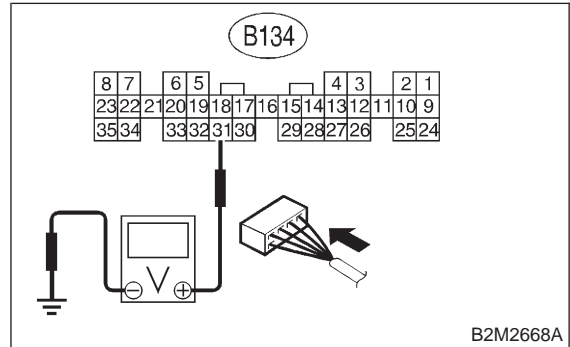

- CHECK** : Does the voltage change more than 10 V by shaking harness and connector of ECM while monitoring the value with voltage meter?
- YES** : Repair battery short circuit in harness between ECM and TCM connector. After repair, replace ECM. <Ref. to 2-7 [W15A0].>
- NO** : Contact with SOA service.

NOTE:

Inspection by DTM is required, because probable cause is deterioration of multiple parts.

BS: DTC P1116 — ENGINE TORQUE CONTROL CUT SIGNAL CIRCUIT LOW INPUT —

● **DTC DETECTING CONDITION:**

- Two consecutive driving cycles with fault

CAUTION:

After repair or replacement of faulty parts, conduct CLEAR MEMORY MODE <Ref. to 2-7 [T3D0].> and INSPECTION MODE <Ref. to 2-7 [T3E0].>

● **WIRING DIAGRAM:**

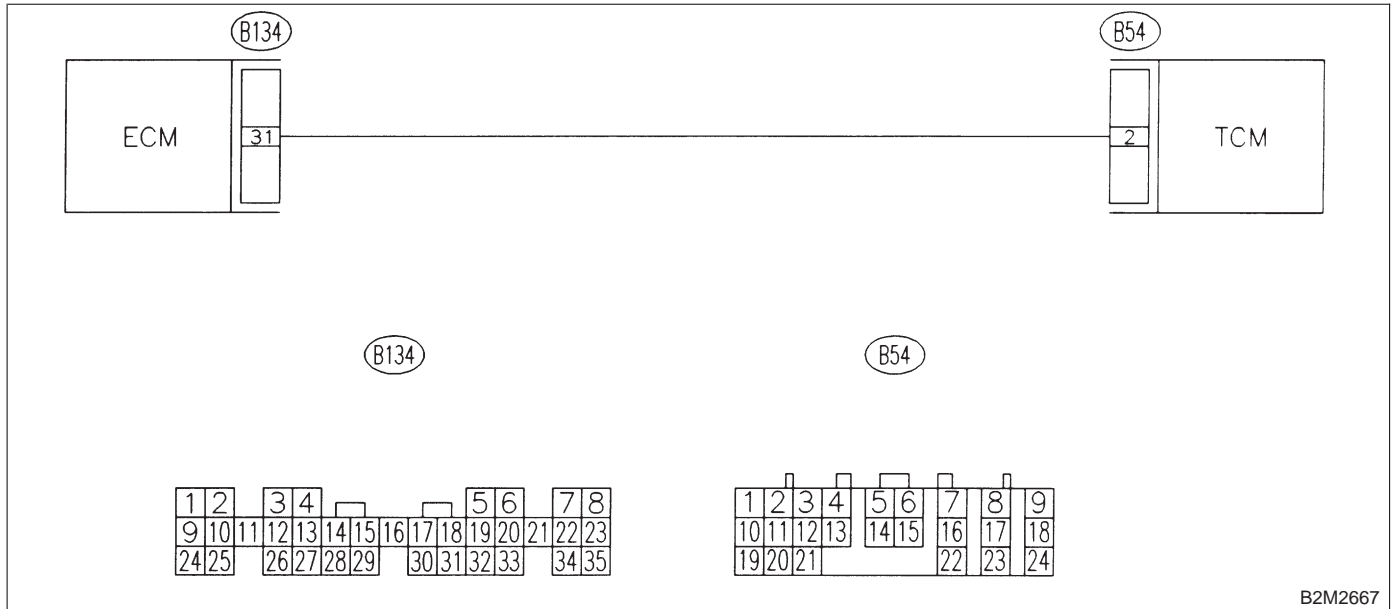

11BS1 : CHECK OUTPUT SIGNAL FROM ECM.

- 1) Start engine, and warm-up the engine.
- 2) Turn ignition switch to OFF.
- 3) Turn ignition switch to ON.
- 4) Measure voltage between ECM and chassis ground.

Connector & terminal
(B134) No. 31 (+) — Chassis ground (-):

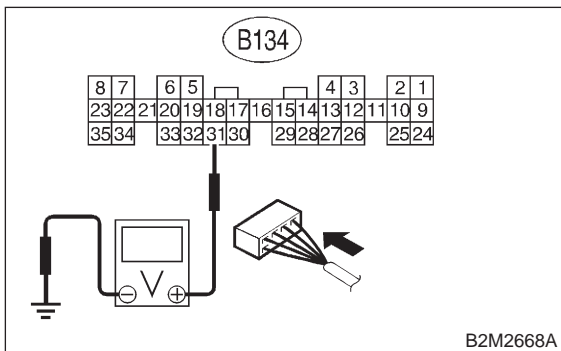

- CHECK** : Is the voltage more than 3 V?
- YES** : Repair poor contact in ECM connector.
- NO** : Go to step 11BS2.

11BS2 : CHECK HARNESS BETWEEN ECM AND TCM CONNECTOR.

- 1) Turn ignition switch to OFF.
- 2) Disconnect connectors from ECM and TCM.
- 3) Measure resistance of harness between ECM and chassis ground.

Connector & terminal
(B134) No. 31 — Chassis ground:

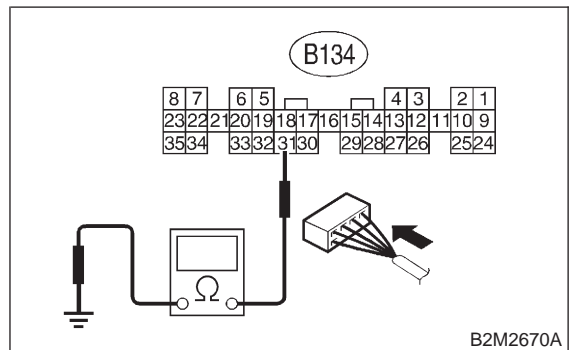

- CHECK** : Is the resistance less than 10 Ω?
- YES** : Repair ground short circuit in harness between ECM and TCM connector.
- NO** : Go to step 11BS3.

2-7 [T11BS3]

ON-BOARD DIAGNOSTICS II SYSTEM

11. Diagnostics Chart with Trouble Code for Except 2200 cc California Spec. Vehicles

11BS3 : CHECK HARNESS BETWEEN ECM AND TCM CONNECTOR.

Measure resistance of harness between ECM and TCM connector.

Connector & terminal

(B134) No. 31 — (B54) No. 2:

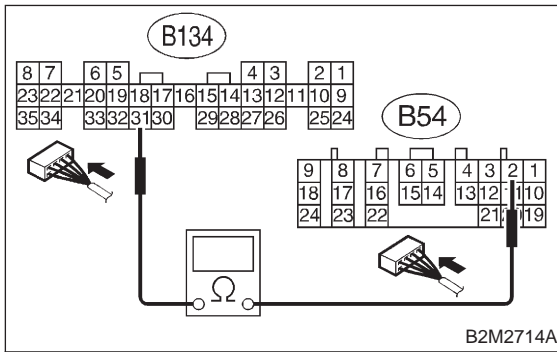

- CHECK** : *Is the resistance less than 1 Ω?*
- YES** : Repair poor contact in ECM or TCM connector.
- NO** : Repair open circuit in harness between ECM and TCM connector.

BT: DTC P1120 — STARTER SWITCH CIRCUIT HIGH INPUT —

- **DTC DETECTING CONDITION:**
 - Two consecutive driving cycles with fault
- **TROUBLE SYMPTOM:**
 - Failure of engine to start

CAUTION:

After repair or replacement of faulty parts, conduct CLEAR MEMORY MODE <Ref. to 2-7 [T3D0].> and INSPECTION MODE <Ref. to 2-7 [T3E0].>

● **WIRING DIAGRAM:**

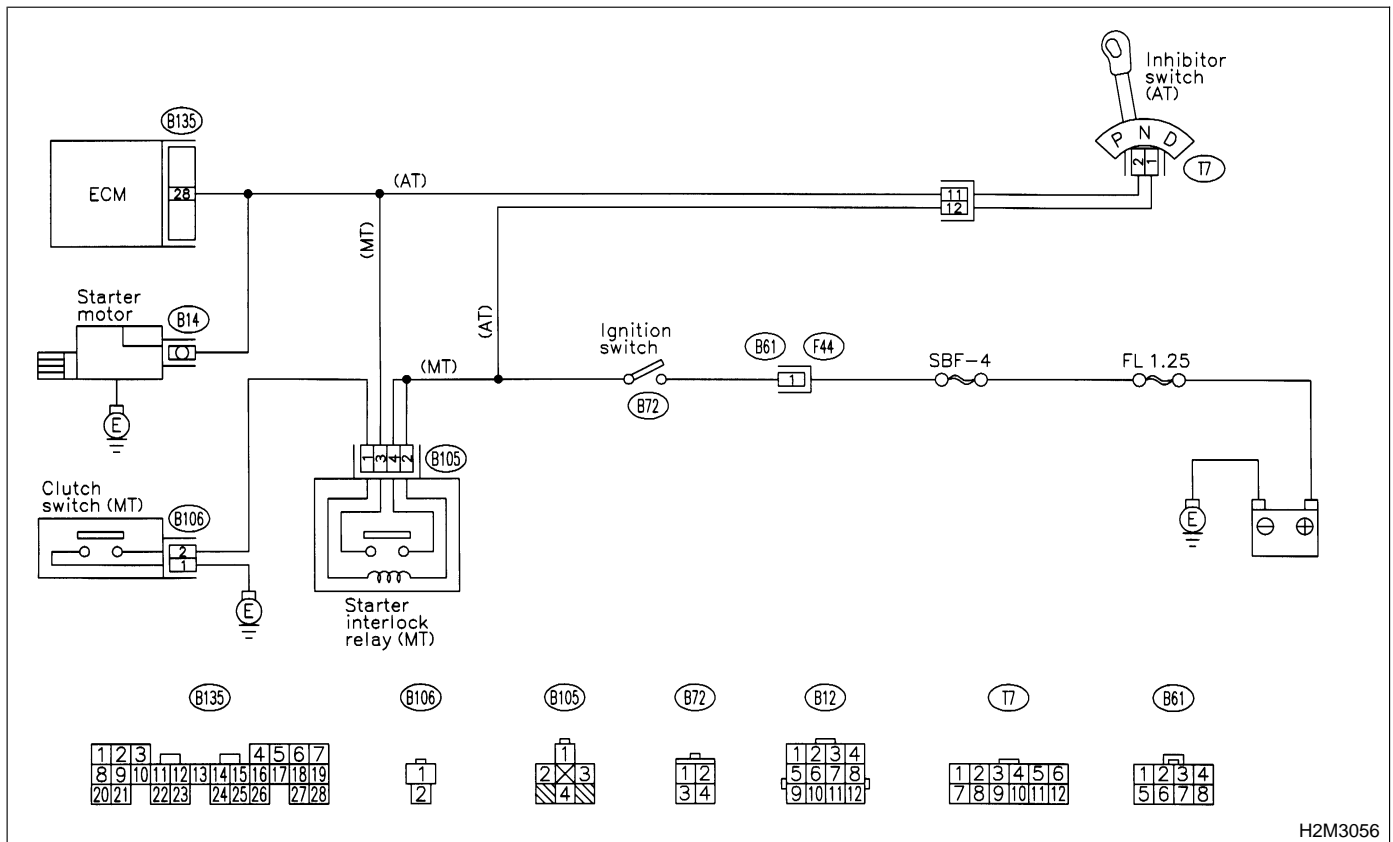

H2M3056

11BT1 : CHECK OPERATION OF STARTER MOTOR.

NOTE:

- On AT vehicles, place the inhibitor switch in each position.
- On MT vehicles, depress or release the clutch pedal.

- CHECK** : *Does starter motor operate when ignition switch to "ON"?*
- YES** : Repair battery short circuit in starter motor circuit. After repair, replace ECM. <Ref. to 2-7 [W15A0].>
- NO** : Check starter motor circuit. <Ref. to 2-7 [T8B0].>

2-7 [T11BT1]

ON-BOARD DIAGNOSTICS II SYSTEM

11. Diagnostics Chart with Trouble Code for Except 2200 cc California Spec. Vehicles

MEMO:

BU: DTC P1121 — NEUTRAL POSITION SWITCH CIRCUIT HIGH INPUT [MT VEHICLES] —

- **DTC DETECTING CONDITION:**
 - Two consecutive driving cycles with fault
- **TROUBLE SYMPTOM:**
 - Erroneous idling

CAUTION:

After repair or replacement of faulty parts, conduct CLEAR MEMORY MODE <Ref. to 2-7 [T3D0].> and INSPECTION MODE <Ref. to 2-7 [T3E0].>

● **WIRING DIAGRAM:**

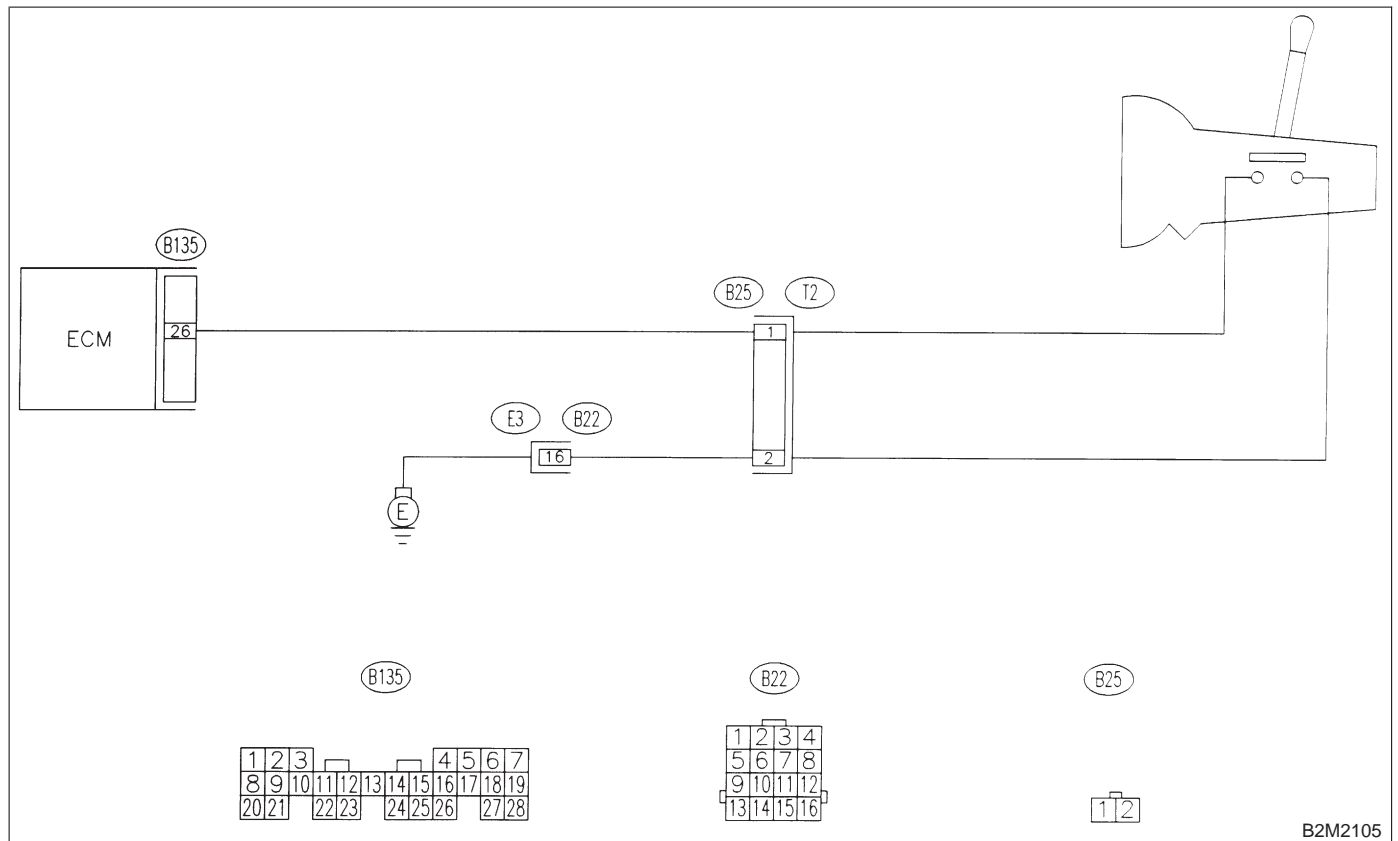

B2M2105

2-7 [T11BU1]

ON-BOARD DIAGNOSTICS II SYSTEM

11. Diagnostics Chart with Trouble Code for Except 2200 cc California Spec. Vehicles

11BU1 : CHECK INPUT SIGNAL FOR ECM.

- 1) Turn ignition switch to ON.
- 2) Measure voltage between ECM and chassis ground.

Connector & terminal

(B135) No. 26 (+) — Chassis ground (-):

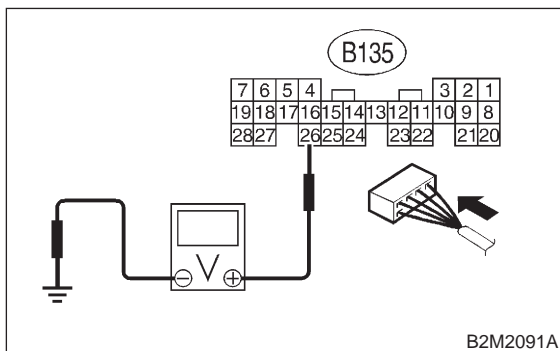

CHECK : *Is the voltage between 4.5 and 5.5 V in neutral position?*

YES : Go to step 11BU2.

NO : Go to step 11BU4.

11BU2 : CHECK INPUT SIGNAL FOR ECM.

Measure voltage between ECM and chassis ground.

Connector & terminal

(B135) No. 26 (+) — Chassis ground (-):

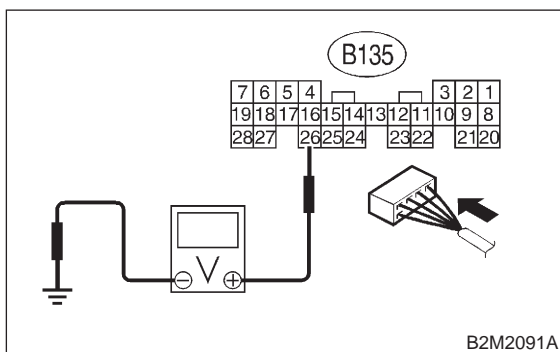

CHECK : *Is the voltage less than 1 V in other positions?*

YES : Go to step 11BU3.

NO : Go to step 11BU4.

11BU3 : CHECK POOR CONTACT.

Check poor contact in ECM connector. <Ref. to FOREWORD [T3C1].>

CHECK : *Is there poor contact in ECM connector?*

YES : Repair poor contact in ECM connector.

NO : Contact with SOA service.

NOTE:

Inspection by DTM is required, because probable cause is deterioration of multiple parts.

11BU4 : CHECK HARNESS BETWEEN ECM AND TCM CONNECTOR.

- 1) Turn ignition switch to OFF.
- 2) Measure voltage between ECM and chassis ground.

Connector & terminal

(B135) No. 26 (+) — Chassis ground (-):

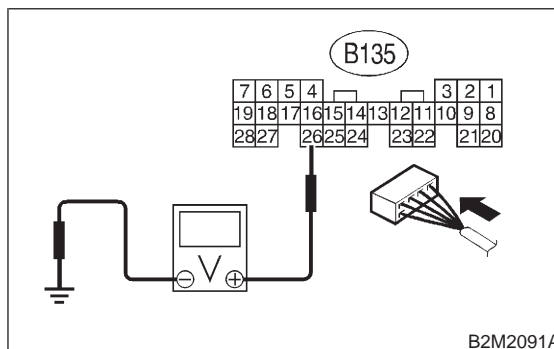

CHECK : *Is the voltage more than 10 V?*

YES : Repair battery short circuit in harness between ECM and transmission harness connector.

NO : Go to step 11BU5.

11BU5 : CHECK HARNESS BETWEEN ECM AND TCM CONNECTOR.

- 1) Turn ignition switch to ON.
- 2) Measure voltage between ECM and chassis ground.

Connector & terminal
(B135) No. 26 (+) — Chassis ground (-):

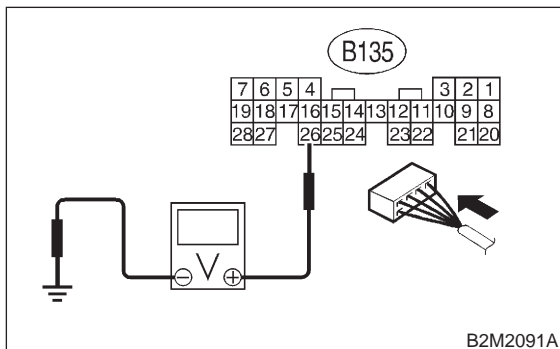

- CHECK** : **Is the voltage more than 10 V?**
- YES** : Repair battery short circuit in harness between ECM and transmission harness connector.
- NO** : Go to step 11BU6.

11BU6 : CHECK NEUTRAL POSITION SWITCH.

Measure resistance between transmission harness connector terminals.

Connector & terminal
(T2) No. 1 — No. 2:

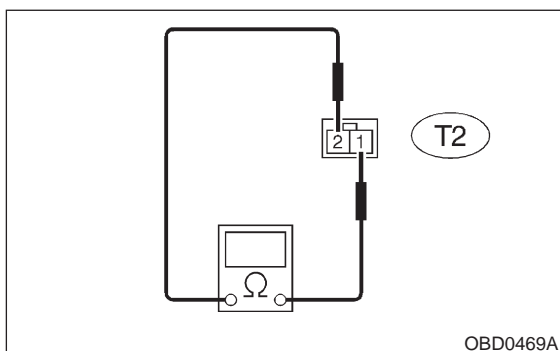

- CHECK** : **Is the resistance less than 1 Ω in other positions?**
- YES** : Go to step 11BU7.
- NO** : Repair open circuit in transmission harness or replace neutral position switch.

11BU7 : CHECK HARNESS BETWEEN ECM AND NEUTRAL POSITION SWITCH CONNECTOR.

- 1) Disconnect connector from ECM.
- 2) Measure resistance of harness between ECM and transmission harness connector.

Connector & terminal
(B135) No. 26 — (B25) No. 1:

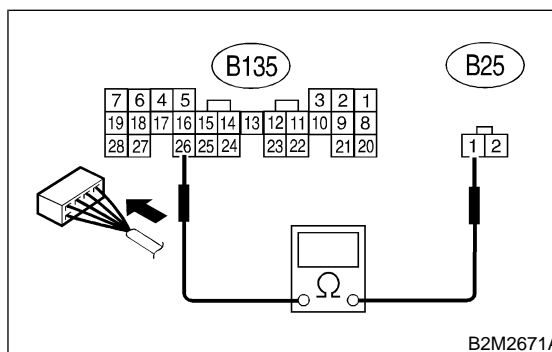

- CHECK** : **Is the resistance less than 1 Ω?**
- YES** : Go to step 11BU8.
- NO** : Repair open circuit in harness between ECM and transmission harness connector.

2-7 [T11BU8]

ON-BOARD DIAGNOSTICS II SYSTEM

11. Diagnostics Chart with Trouble Code for Except 2200 cc California Spec. Vehicles

11BU8 : CHECK HARNESS BETWEEN ECM AND NEUTRAL POSITION SWITCH CONNECTOR.

Measure resistance of harness between transmission harness connector and engine ground.

Connector & terminal

(B25) No. 2 — Engine ground:

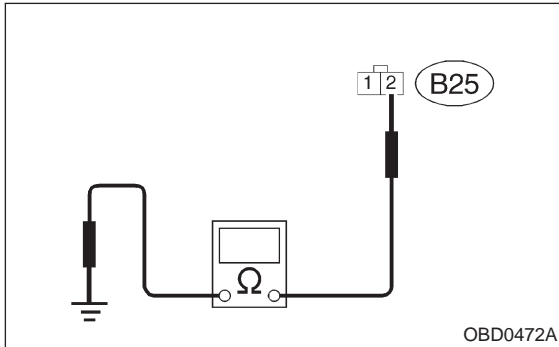

CHECK : *Is the resistance less than 5 Ω ?*

YES : Go to step 11BU9.

NO : Repair harness and connector.

NOTE:

In this case, repair the following:

- Open circuit in harness between transmission harness connector and engine grounding terminal
- Poor contact in coupling connector (B22)

11BU9 : CHECK POOR CONTACT.

Check poor contact in transmission harness connector. <Ref. to FOREWORD [T3C1].>

CHECK : *Is there poor contact in transmission harness connector?*

YES : Repair poor contact in transmission harness connector.

NO : Contact with SOA service.

NOTE:

Inspection by DTM is required, because probable cause is deterioration of multiple parts.

BV: DTC P1121 — NEUTRAL POSITION SWITCH CIRCUIT LOW INPUT [AT VEHICLES] —

- **DTC DETECTING CONDITION:**
 - Two consecutive driving cycles with fault
- **TROUBLE SYMPTOM:**
 - Erroneous idling

CAUTION:

After repair or replacement of faulty parts, conduct **CLEAR MEMORY MODE** <Ref. to 2-7 [T3D0].> and **INSPECTION MODE** <Ref. to 2-7 [T3E0].>

● **WIRING DIAGRAM:**

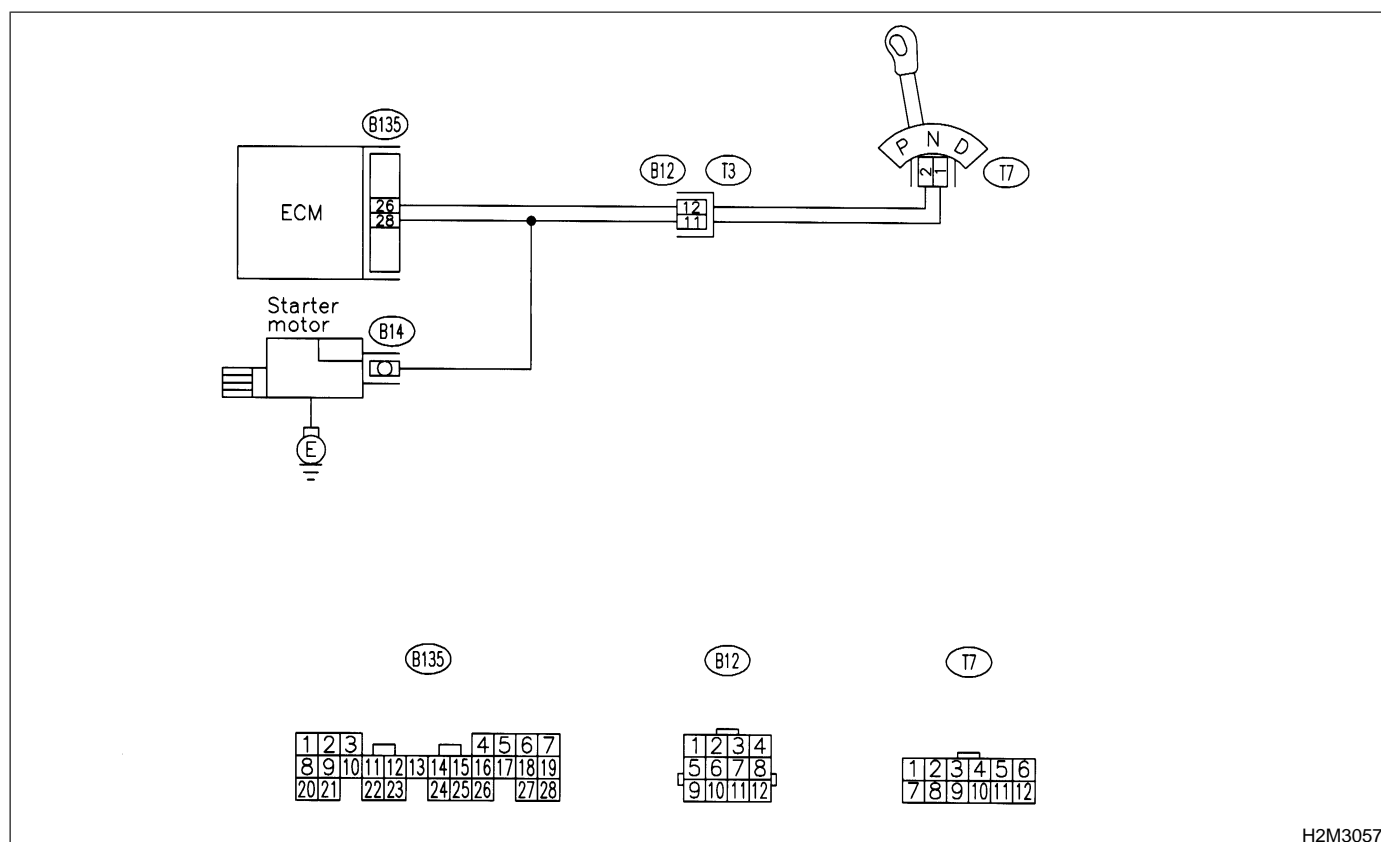

11BV1 : CHECK DTC P0705 ON DISPLAY.

- CHECK** : *Does the Subaru Select Monitor or OBD-II general scan tool indicate DTC P0705?*
- YES** : Inspect DTC P0705 using "11. Diagnostics Chart with Trouble Code for Except 2200 cc California Spec. Vehicles". <Ref. to 2-7 [T11A0].>
- NO** : Go to step **11BV2**.

2-7 [T11BV2]

ON-BOARD DIAGNOSTICS II SYSTEM

11. Diagnostics Chart with Trouble Code for Except 2200 cc California Spec. Vehicles

11BV2 : CHECK INPUT SIGNAL FOR ECM.

- 1) Turn ignition switch to ON.
- 2) Measure voltage between ECM and chassis ground.

Connector & terminal

(B135) No. 26 (+) — Chassis ground (-):

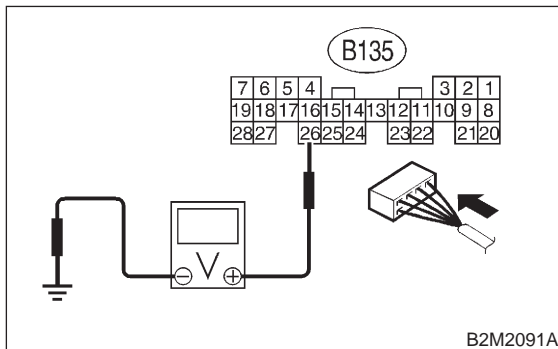

- CHECK** : Is the voltage between 4.5 and 5.5 V in other positions?
- YES** : Even if MIL lights up, the circuit has returned to a normal condition at this time.
- NO** : Go to step 11BV3.

11BV3 : CHECK HARNESS BETWEEN ECM AND TRANSMISSION HARNESS CONNECTOR.

- 1) Turn ignition switch to OFF.
- 2) Disconnect connectors from ECM and transmission harness connector.
- 3) Measure resistance of harness between ECM connector and chassis ground.

Connector & terminal

(B135) No. 26 — Chassis ground:

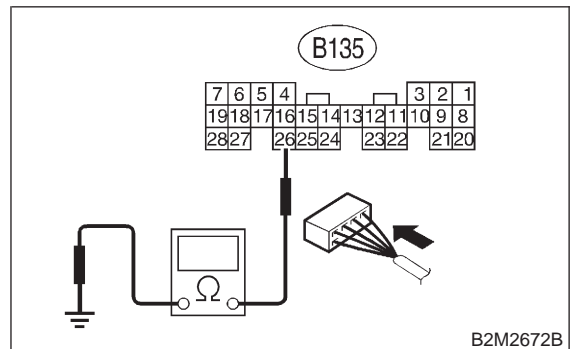

- CHECK** : Is the resistance less than 10 Ω?
- YES** : Repair ground short circuit in harness between ECM and transmission harness connector.
- NO** : Go to step 11BV4.

11BV4 : CHECK TRANSMISSION HARNESS CONNECTOR.

- 1) Disconnect connector from inhibitor switch.
- 2) Measure resistance of harness between transmission harness connector and engine ground.

Connector & terminal

(T3) No. 12 — Engine ground:

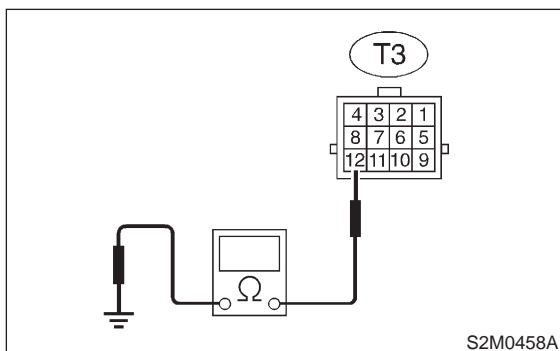

- CHECK** : *Is the resistance less than 10 Ω?*
- YES** : Repair ground short circuit in harness between transmission harness and inhibitor switch connector.
- NO** : Go to step **11BV5**.

11BV5 : CHECK INHIBITOR SWITCH.

Measure resistance between inhibitor switch connector receptacle's terminals in selector lever except for "N" position.

Terminals

No. 2 — No. 1:

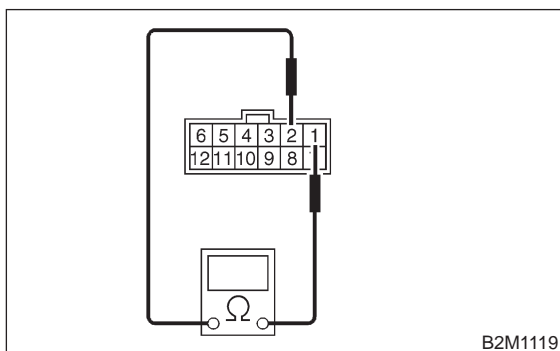

- CHECK** : *Is the resistance more than 1 MΩ in other positions?*
- YES** : Go to step **11BV6**.
- NO** : Replace inhibitor switch. <Ref. to 3-2 [W2C0].>

11BV6 : CHECK SELECTOR CABLE CONNECTION.

- CHECK** : *Is there any fault in selector cable connection to inhibitor switch?*
- YES** : Repair selector cable connection. <Ref. to 3-2 [W2A0].>
- NO** : Contact with SOA service.

NOTE:

Inspection by DTM is required, because probable cause is deterioration of multiple parts.

2-7 [T11BV6]

ON-BOARD DIAGNOSTICS II SYSTEM

11. Diagnostics Chart with Trouble Code for Except 2200 cc California Spec. Vehicles

MEMO:

BW: DTC P1122 — PRESSURE SOURCES SWITCHING SOLENOID VALVE CIRCUIT HIGH INPUT —

- **DTC DETECTING CONDITION:**
 - Two consecutive driving cycles with fault
- **TROUBLE SYMPTOM:**
 - Erroneous idling
 - Failure of engine to start

CAUTION:

After repair or replacement of faulty parts, conduct CLEAR MEMORY MODE <Ref. to 2-7 [T3D0].> and INSPECTION MODE <Ref. to 2-7 [T3E0].>

● **WIRING DIAGRAM:**

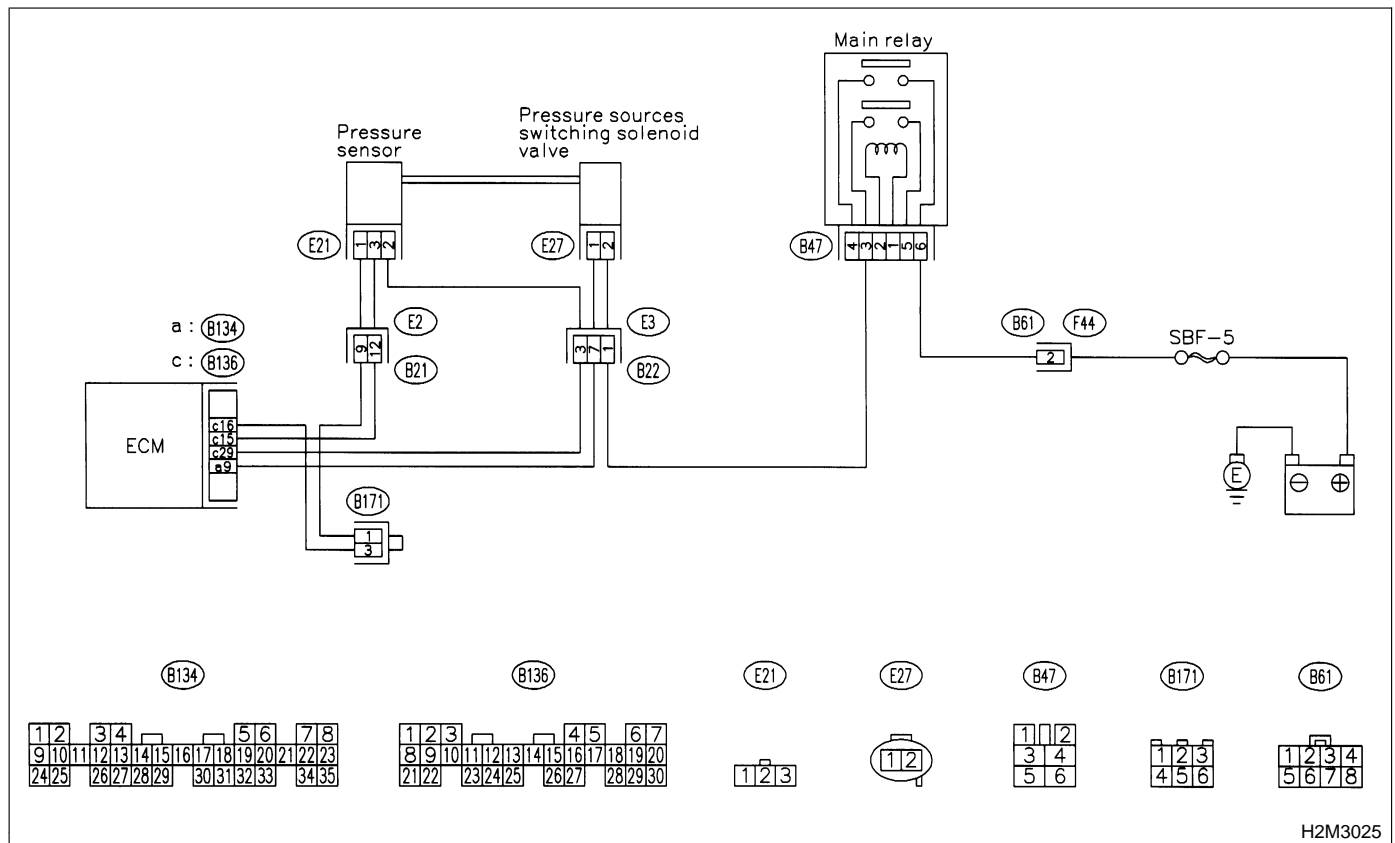

H2M3025

2-7 [T11BW1]

ON-BOARD DIAGNOSTICS II SYSTEM

11. Diagnostics Chart with Trouble Code for Except 2200 cc California Spec. Vehicles

11BW1 : CHECK OUTPUT SIGNAL FROM ECM.

- 1) Turn ignition switch to ON.
- 2) Measure voltage between ECM and chassis ground.

Connector & terminal

(B134) No. 9 (+) — Chassis ground (-):

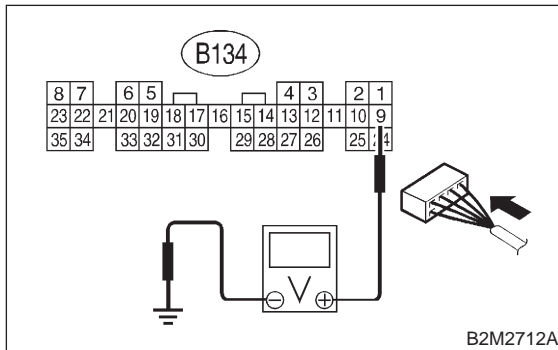

- CHECK** : Is the voltage more than 10 V?
YES : Go to step 11BW3.
NO : Go to step 11BW2.

11BW2 : CHECK POOR CONTACT.

Check poor contact in ECM connector. <Ref. to FOREWORD [T3C1].>

- CHECK** : Is there poor contact in ECM connector?
YES : Repair poor contact in ECM connector.
NO : Replace ECM. <Ref. to 2-7 [W15A0].>

11BW3 : CHECK HARNESS BETWEEN ECM AND PRESSURE SOURCES SWITCHING SOLENOID VALVE CONNECTOR.

- 1) Turn ignition switch to OFF.
- 2) Disconnect connector from pressure sources switching solenoid valve.
- 3) Turn ignition switch to ON.
- 4) Measure voltage between ECM and chassis ground.

Connector & terminal

(B134) No. 9 (+) — Chassis ground (-):

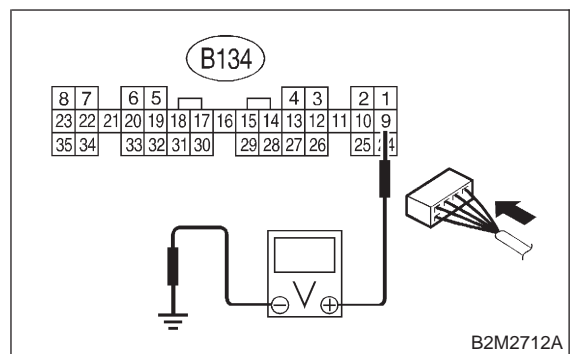

- CHECK** : Is the voltage more than 10 V?
YES : Repair battery short circuit in harness between ECM and pressure sources switching solenoid valve connector. After repair, replace ECM. <Ref. to 2-7 [W15A0].>
NO : Go to step 11BW4.

11BW4 : CHECK PRESSURE SOURCES SWITCHING SOLENOID VALVE.

- 1) Turn ignition switch to OFF.
- 2) Measure resistance between pressure sources switching solenoid valve connector terminals.

Terminals

No. 2 — No. 1:

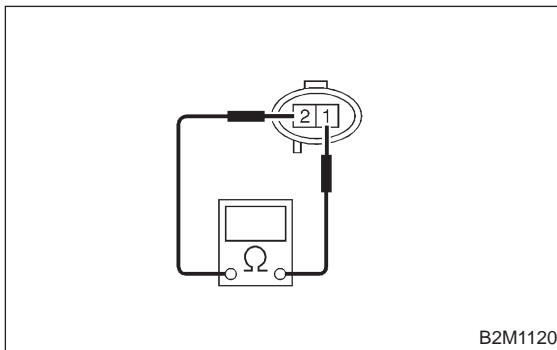

- CHECK** : **Is the resistance less than 1 Ω?**
- YES** : Replace pressure sources switching solenoid valve <Ref. to 2-7 [W13A0].> and ECM <Ref. to 2-7 [W15A0].>.
- NO** : Go to step **11BW5**.

11BW5 : CHECK POOR CONTACT.

Check poor contact in ECM connector. <Ref. to FOREWORD [T3C1].>

- CHECK** : **Is there poor contact in ECM connector?**
- YES** : Repair poor contact in ECM connector.
- NO** : Replace ECM. <Ref. to 2-7 [W15A0].>

MEMO:

BX: DTC P1141 — MASS AIR FLOW SENSOR CIRCUIT RANGE/PERFORMANCE PROBLEM (LOW INPUT) —

- **DTC DETECTING CONDITION:**
 - Two consecutive driving cycles with fault
- **TROUBLE SYMPTOM:**
 - Erroneous idling
 - Engine stalls.
 - Poor driving performance

CAUTION:

After repair or replacement of faulty parts, conduct CLEAR MEMORY MODE <Ref. to 2-7 [T3D0].> and INSPECTION MODE <Ref. to 2-7 [T3E0].>

● **WIRING DIAGRAM:**

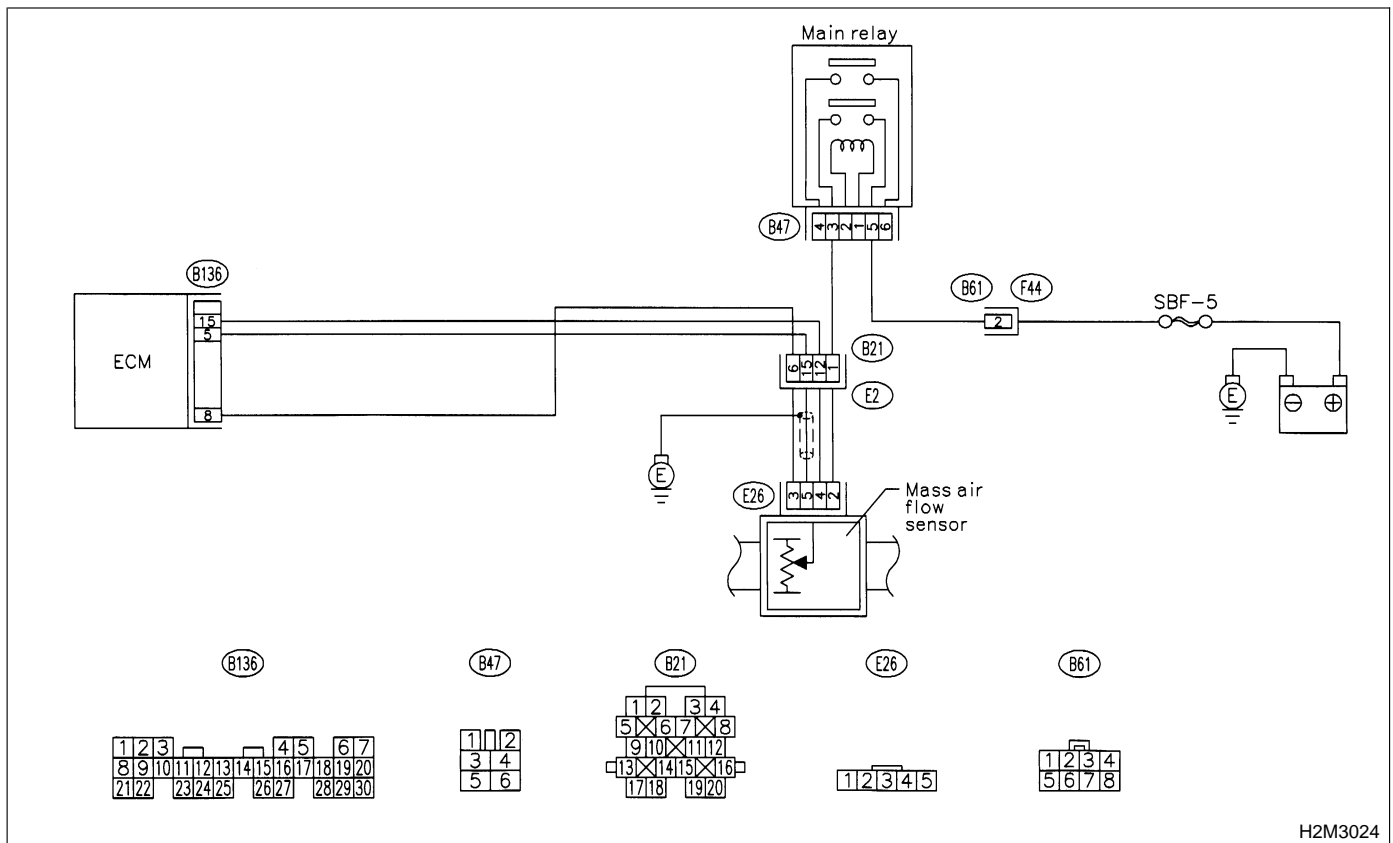

H2M3024

2-7 [T11BX1]

ON-BOARD DIAGNOSTICS II SYSTEM

11. Diagnostics Chart with Trouble Code for Except 2200 cc California Spec. Vehicles

11BX1 : CHECK ANY OTHER DTC ON DISPLAY.

CHECK : *Does the Subaru Select Monitor or OBD-II general scan tool indicate DTC P0102, P0103 or P0122?*

YES : Inspect DTC P0102, P0103 or P0122 using "11. Diagnostics Chart with Trouble Code for Except 2200 cc California Spec. Vehicles". <Ref. to 2-7 [T11A0].>

NOTE:

In this case, it is not necessary to inspect DTC P1141.

NO : Go to step 11BX2.

11BX2 : CHECK THROTTLE POSITION SENSOR.

Measure voltage between ECM and chassis ground while throttle valve is fully closed.

Connector & terminal

(B136) No. 15 (+) — Chassis ground (-):

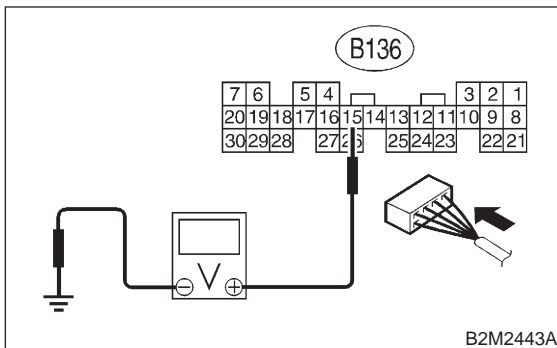

CHECK : *Is the voltage less than 0.1 V?*

YES : Go to step 11BX3.

NO : Check throttle position sensor circuit. <Ref. to 2-7 [T11K0].>

11BX3 : CHECK THROTTLE POSITION SENSOR.

Measure voltage between ECM and chassis ground while throttle valve is fully opened.

Connector & terminal

(B136) No. 15 (+) — Chassis ground (-):

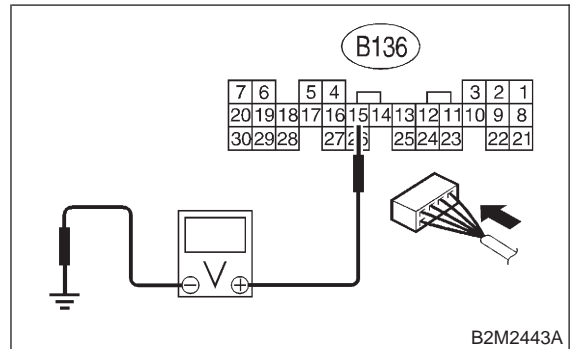

CHECK : *Is the voltage more than 4.5 V?*

YES : Replace mass air flow sensor. <Ref. to 2-7 [W2A1].>

NO : Check throttle position sensor circuit. <Ref. to 2-7 [T11K0].>

BY: DTC P1142 — THROTTLE POSITION SENSOR CIRCUIT RANGE/PERFORMANCE PROBLEM (LOW INPUT) —

- **DTC DETECTING CONDITION:**
 - Two consecutive driving cycles with fault
- **TROUBLE SYMPTOM:**
 - Erroneous idling
 - Engine stalls.
 - Poor driving performance

CAUTION:

After repair or replacement of faulty parts, conduct **CLEAR MEMORY MODE** <Ref. to 2-7 [T3D0].> and **INSPECTION MODE** <Ref. to 2-7 [T3E0].>.

● **WIRING DIAGRAM:**

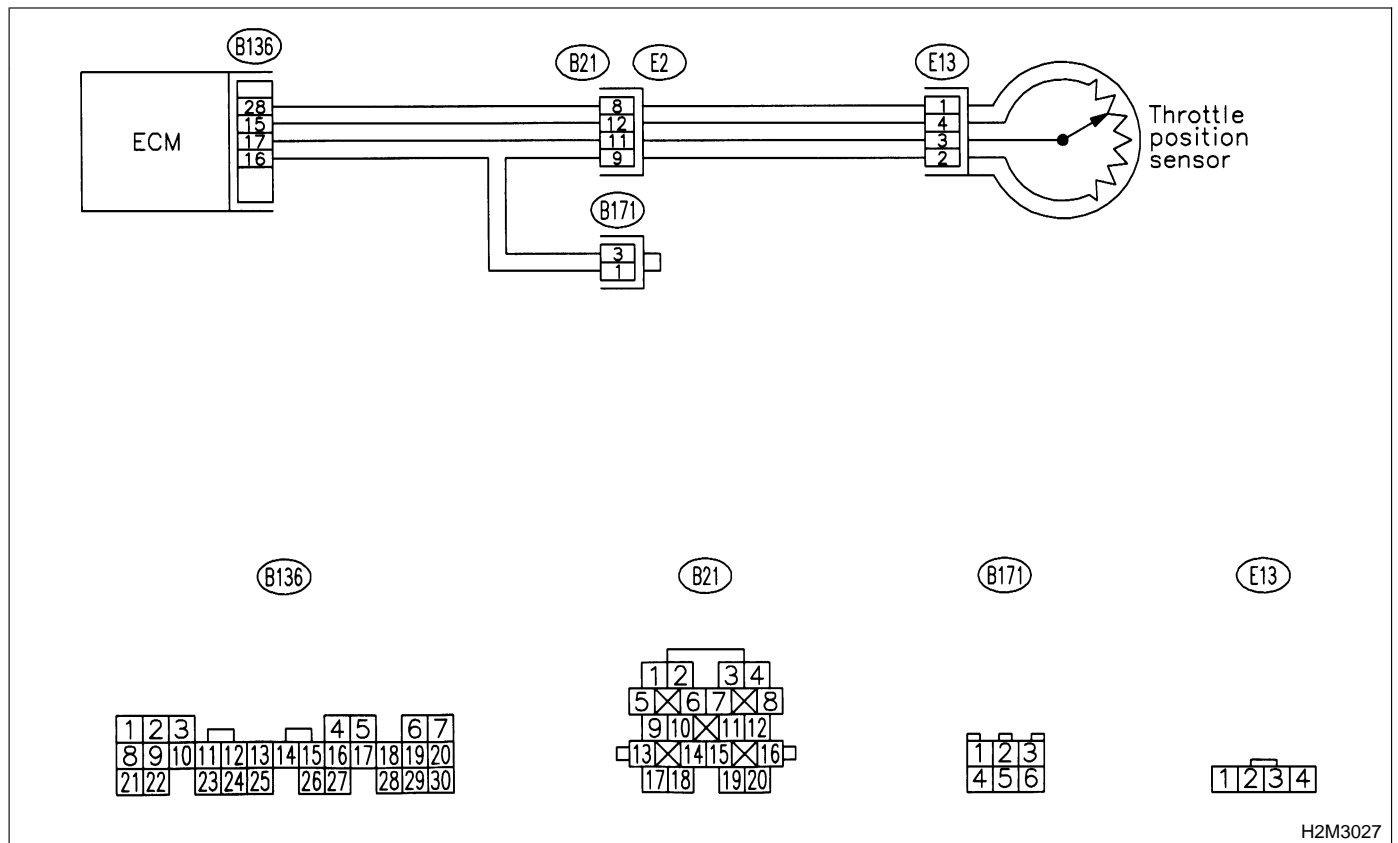

H2M3027

2-7 [T11BY1]

ON-BOARD DIAGNOSTICS II SYSTEM

11. Diagnostics Chart with Trouble Code for Except 2200 cc California Spec. Vehicles

11BY1 : CHECK ANY OTHER DTC ON DISPLAY.

CHECK : *Does the Subaru Select Monitor or OBD-II general scan tool indicate DTC P0122 or P0123?*

YES : Inspect DTC P0122 or P0123 using "11. Diagnostics Chart with Trouble Code for Except 2200 cc California Spec. Vehicles". <Ref. to 2-7 [T11A0].>

NOTE:

In this case, it is not necessary to inspect DTC P1142.

NO : Replace throttle position sensor. <Ref. to 2-7 [W9A0].>

BZ: DTC P1143 — PRESSURE SENSOR CIRCUIT RANGE/PERFORMANCE PROBLEM (LOW INPUT) —

- DTC DETECTING CONDITION:
 - Two consecutive driving cycles with fault

CAUTION:

After repair or replacement of faulty parts, conduct CLEAR MEMORY MODE <Ref. to 2-7 [T3D0].> and INSPECTION MODE <Ref. to 2-7 [T3E0].>

● WIRING DIAGRAM:

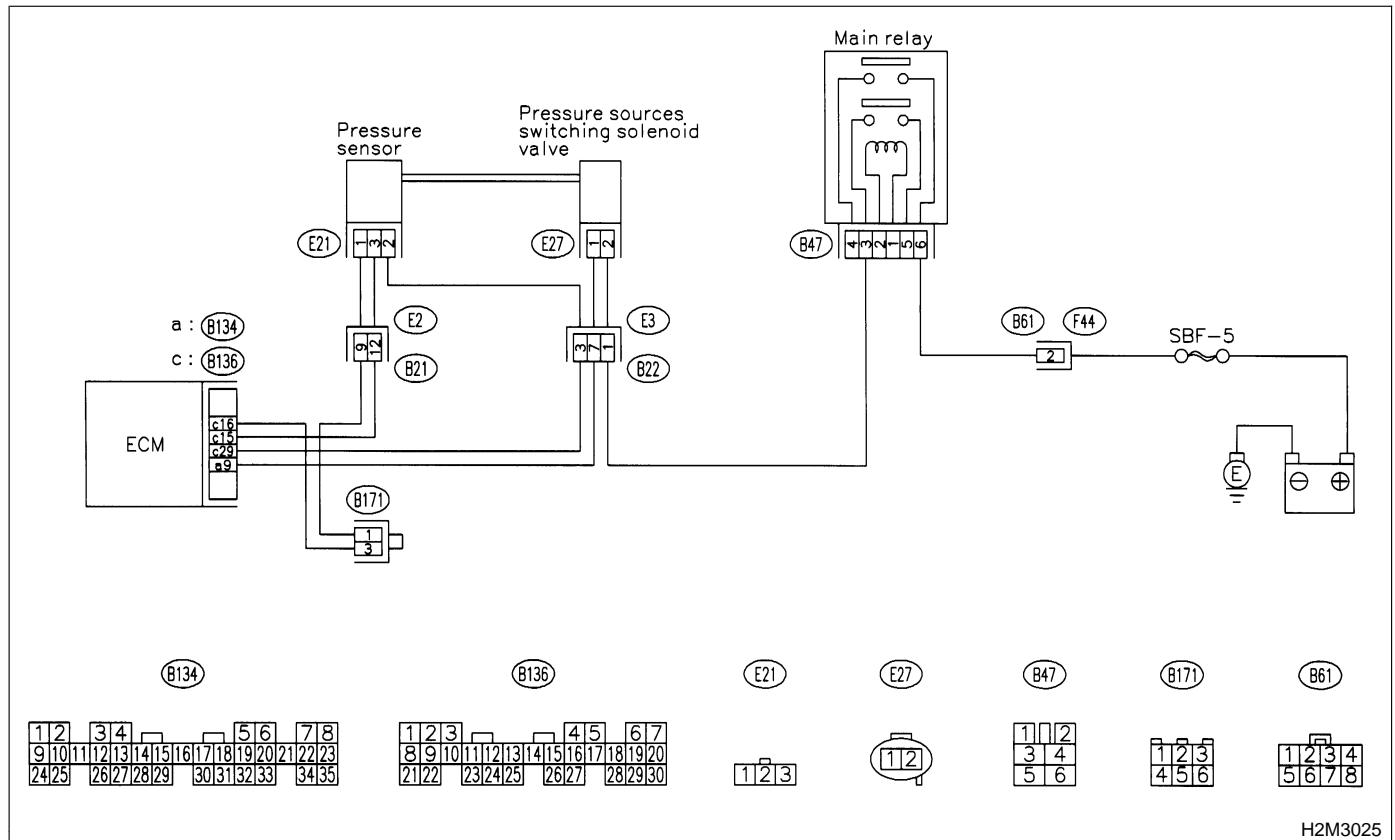

2-7 [T11BZ1]

ON-BOARD DIAGNOSTICS II SYSTEM

11. Diagnostics Chart with Trouble Code for Except 2200 cc California Spec. Vehicles

11BZ1 : CHECK IDLE SWITCH SIGNAL.

- 1) Turn ignition switch to OFF.
- 2) Connect Subaru Select Monitor to data link connector.

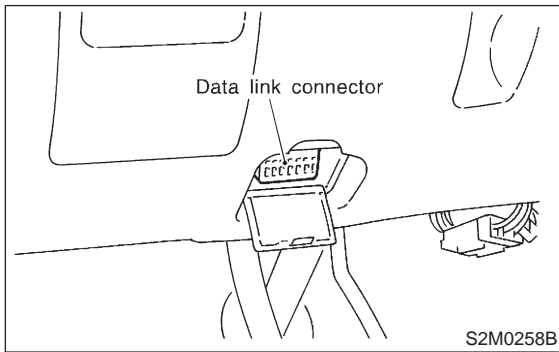

- 3) Turn ignition switch to ON and Subaru Select Monitor switch to ON.
- 4) Operate the LED operation mode for engine using Subaru Select Monitor.

NOTE:

- Subaru Select Monitor

For detailed operation procedure, refer to the "LED OPERATION MODE FOR ENGINE". <Ref. to 2-7 [T3C8].>

CHECK : **Does the LED of {Idle Switch Signal} come on?**

YES : Go to step **11BZ2**.

NO : Check throttle position sensor circuit. <Ref. to 2-7 [T11K0].>

NOTE:

In this case, it is not necessary to inspect DTC P1143.

11BZ2 : CHECK DATA FOR CONTROL.

- 1) Turn ignition switch to OFF.
- 2) Connect Subaru Select Monitor or the OBD-II general scan tool to data link connector.

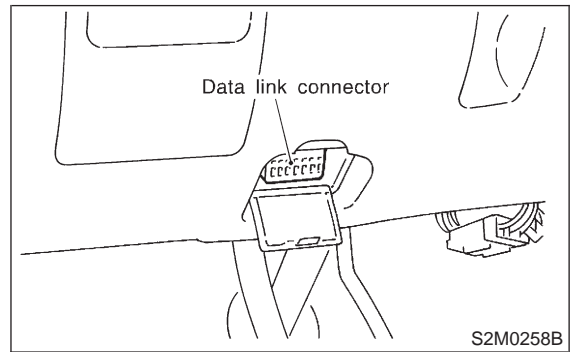

- 3) Turn ignition switch ON and Subaru Select Monitor or the OBD-II general scan tool switch ON.
- 4) Start engine.
- 5) Read data of atmospheric absolute pressure signal using Subaru Select Monitor or OBD-II general scan tool.

NOTE:

- Subaru Select Monitor

For detailed operation procedure, refer to the "READ CURRENT DATA SHOWN ON DISPLAY FOR ENGINE". <Ref. to 2-7 [T3C4].>

- OBD-II general scan tool

For detailed operation procedures, refer to the OBD-II General Scan Tool Instruction Manual.

CHECK : **Is the value less than 32 kPa (240 mmHg, 9.45 inHg)?**

YES : Go to step **11BZ4**.

NO : Go to step **11BZ3**.

11BZ3 : CHECK PRESSURE SENSOR.

- 1) Measure actual atmospheric pressure.
- 2) Read data of atmospheric absolute pressure signal using Subaru Select Monitor or OBD-II general scan tool.

NOTE:

- Subaru Select Monitor

For detailed operation procedure, refer to the "READ CURRENT DATA SHOWN ON DISPLAY FOR ENGINE". <Ref. to 2-7 [T3C4].>

CHECK : *Is the difference between absolute value of Subaru Selector Monitor indication and actual atmospheric pressure greater than 10 kPa (75 mmHg, 2.95 inHg)?*

- YES** : Replace pressure sensor.
- NO** : Even if MIL lights up, the circuit has returned to a normal condition at this time. Contact with SOA service.

NOTE:

Inspection by DTM is required, because probable cause is deterioration of multiple parts.

11BZ4 : CHECK VACUUM HOSES.

Check the following item. Incorrect hose connections in line between the pressure sources switching solenoid valve and pressure sensor, intake manifold and/or purge control solenoid valve.

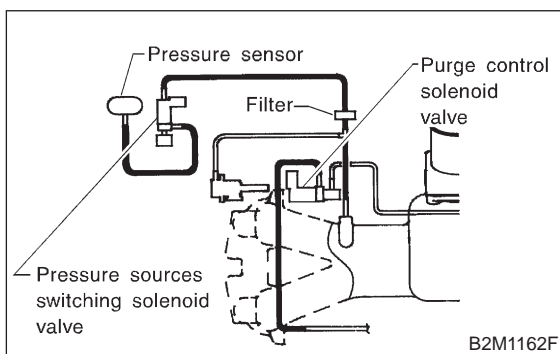

- CHECK** : *Is there a fault in vacuum hose?*
- YES** : Repair or replace hoses or filter.
- NO** : Go to step 11BZ5.

11BZ5 : CHECK PRESSURE SOURCES SWITCHING SOLENOID VALVE.

- 1) Turn ignition switch to OFF.
- 2) Connect test mode connector.

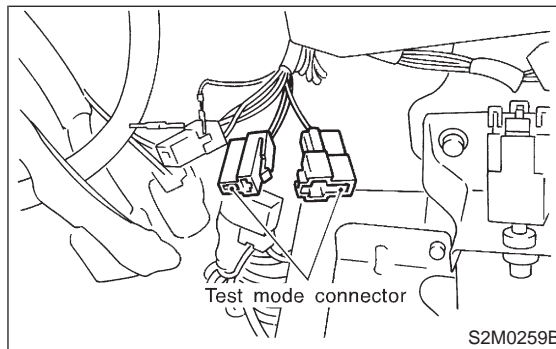

- 3) Turn ignition switch to ON.

NOTE:

Pressure sources switching solenoid valve operation check can also be executed using Subaru Select Monitor. For the procedure, refer to the "COMPULSORY VALVE OPERATION CHECK MODE". <Ref. to 2-7 [T3F0].>

- CHECK** : *Does pressure sources switching solenoid valve produce operating sound? (ON ↔ OFF each 1.5 sec.)*
- YES** : Replace pressure sensor. <Ref. to 2-7 [W11A0].>
- NO** : Replace pressure sources switching solenoid valve. <Ref. to 2-7 [W13A0].>

2-7 [T11BZ5]

ON-BOARD DIAGNOSTICS II SYSTEM

11. Diagnostics Chart with Trouble Code for Except 2200 cc California Spec. Vehicles

MEMO:

CA: DTC P1144 — PRESSURE SENSOR CIRCUIT RANGE/PERFORMANCE PROBLEM (HIGH INPUT) —

- DTC DETECTING CONDITION:
 - Two consecutive driving cycles with fault

CAUTION:

After repair or replacement of faulty parts, conduct CLEAR MEMORY MODE <Ref. to 2-7 [T3D0].> and INSPECTION MODE <Ref. to 2-7 [T3E0].>

● WIRING DIAGRAM:

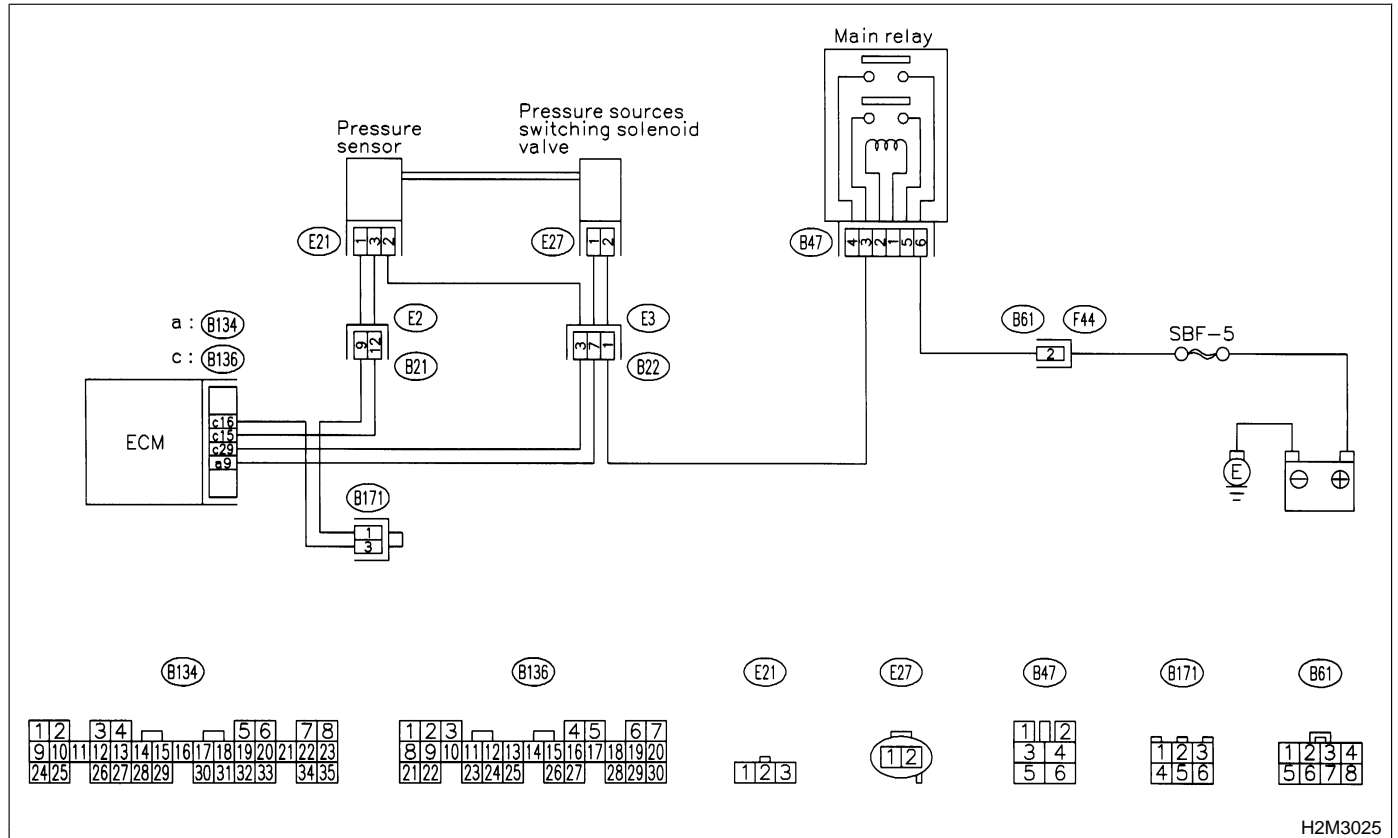

2-7 [T11CA1]

ON-BOARD DIAGNOSTICS II SYSTEM

11. Diagnostics Chart with Trouble Code for Except 2200 cc California Spec. Vehicles

11CA1 : CHECK IDLE SWITCH SIGNAL.

- 1) Turn ignition switch to OFF.
- 2) Connect Subaru Select Monitor to data link connector.

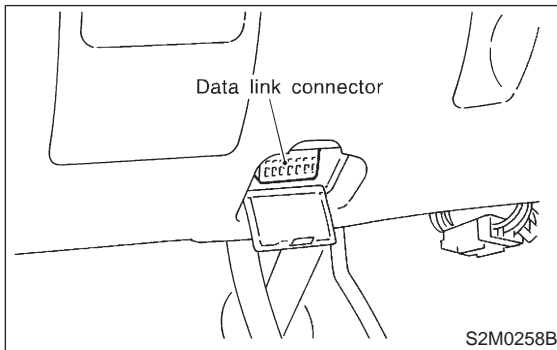

- 3) Turn ignition switch to ON and Subaru Select Monitor switch to ON.
- 4) Operate the LED operation mode for engine using Subaru Select Monitor.

NOTE:

- Subaru Select Monitor

For detailed operation procedure, refer to the "LED OPERATION MODE FOR ENGINE". <Ref. to 2-7 [T3C8].>

CHECK : **Does the LED of {Idle Switch Signal} come on?**

YES : Go to step 11CA2.

NO : Check throttle position sensor circuit. <Ref. to 2-7 [T11K0].>

NOTE:

In this case, it is not necessary to inspect DTC P1144.

11CA2 : CHECK DATA FOR CONTROL.

- 1) Turn ignition switch to OFF.
- 2) Connect Subaru Select Monitor or the OBD-II general scan tool to data link connector.

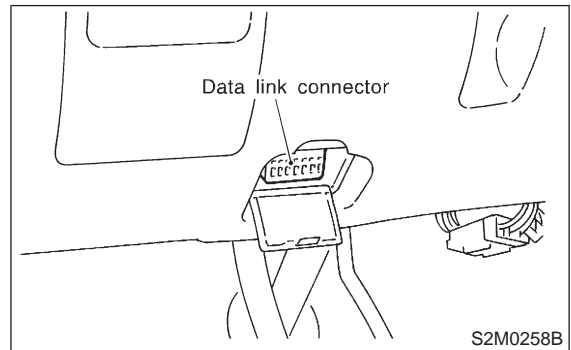

- 3) Turn ignition switch ON and Subaru Select Monitor or the OBD-II general scan tool switch ON.
- 4) Start engine.
- 5) Read data of atmospheric absolute pressure signal using Subaru Select Monitor or OBD-II general scan tool.

NOTE:

- Subaru Select Monitor

For detailed operation procedure, refer to the "READ CURRENT DATA SHOWN ON DISPLAY FOR ENGINE". <Ref. to 2-7 [T3C4].>

- OBD-II general scan tool

For detailed operation procedures, refer to the OBD-II General Scan Tool Instruction Manual.

CHECK : **Is the value more than 133 kPa (998 mmHg, 39.29 inHg)?**

YES : Replace pressure sensor. <Ref. to 2-7 [W11A0].>

NO : Even if MIL lights up, the circuit has returned to a normal condition at this time. Contact with SOA service.

NOTE:

Inspection by DTM is required, because probable cause is deterioration of multiple parts.

CB: DTC P1150 — FRONT OXYGEN SENSOR HEATER CIRCUIT HIGH INPUT

● **DTC DETECTING CONDITION:**

- Two consecutive driving cycles with fault

CAUTION:

After repair or replacement of faulty parts, conduct CLEAR MEMORY MODE <Ref. to 2-7 [T3D0].> and INSPECTION MODE <Ref. to 2-7 [T3E0].>

● **WIRING DIAGRAM:**

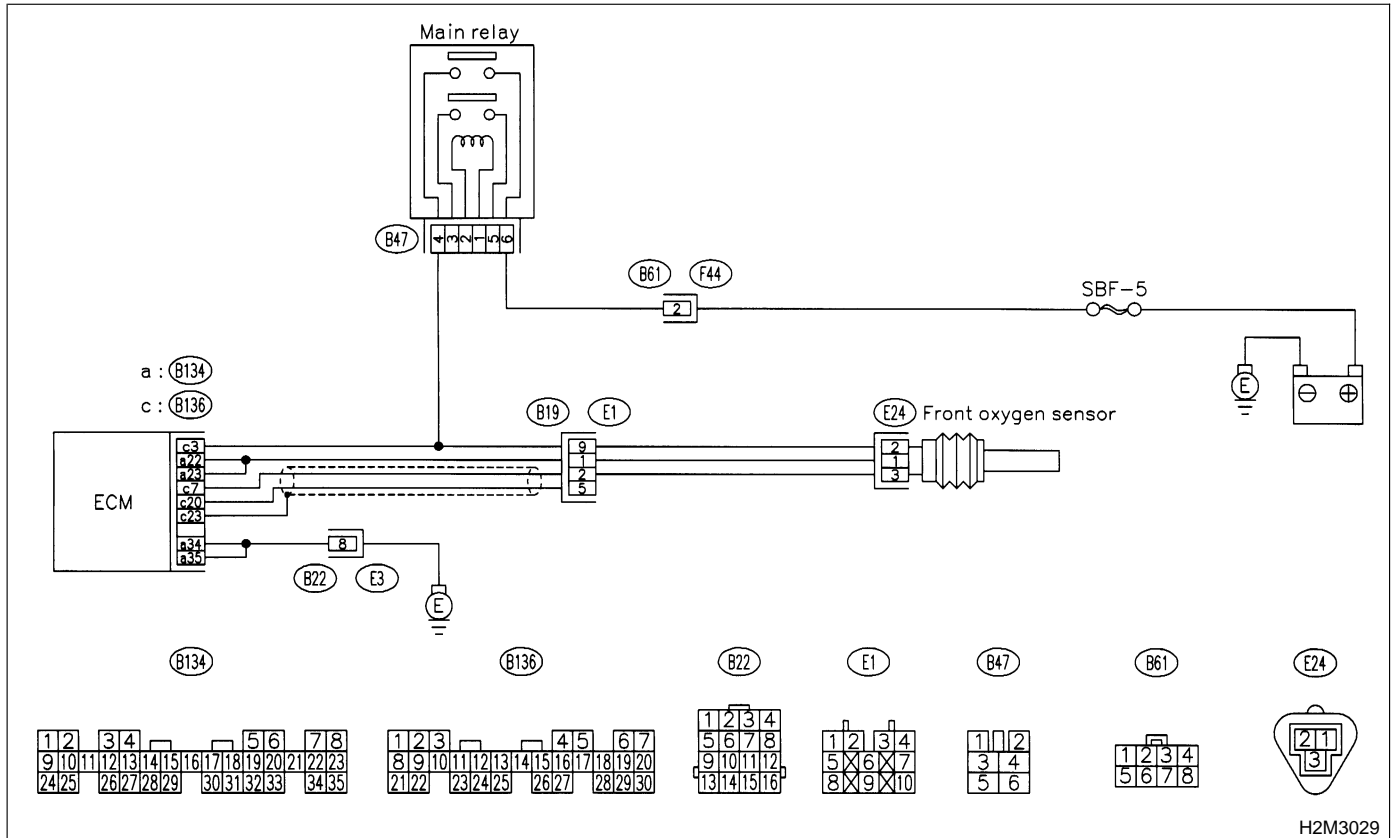

H2M3029

2-7 [T11CB1]

ON-BOARD DIAGNOSTICS II SYSTEM

11. Diagnostics Chart with Trouble Code for Except 2200 cc California Spec. Vehicles

11CB1 : CHECK OUTPUT SIGNAL FROM ECM.

- 1) Turn ignition switch to ON.
- 2) Measure voltage between ECM connector and chassis ground.

Connector & terminal

(B134) No. 23 (+) — Chassis ground (-):

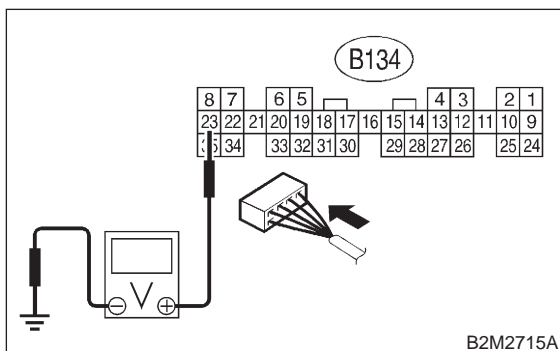

- CHECK** : **Is the voltage more than 8 V?**
- YES** : Go to step 11CB3.
- NO** : Go to step 11CB2.

11CB2 : CHECK OUTPUT SIGNAL FROM ECM.

Measure voltage between ECM connector and chassis ground.

Connector & terminal

(B134) No. 22 (+) — Chassis ground (-):

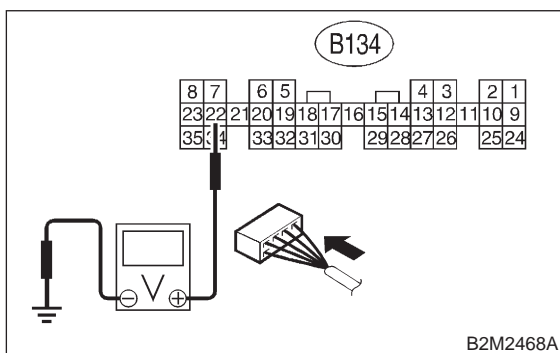

- CHECK** : **Is the voltage more than 8 V?**
- YES** : Go to step 11CB3.
- NO** : Go to step 11CB4.

11CB3 : CHECK FRONT OXYGEN SENSOR HEATER CURRENT.

- 1) Turn ignition switch to OFF.
- 2) Repair battery short circuit in harness between ECM and front oxygen sensor connector.
- 3) Connect Subaru Select Monitor or the OBD-II general scan tool to data link connector.

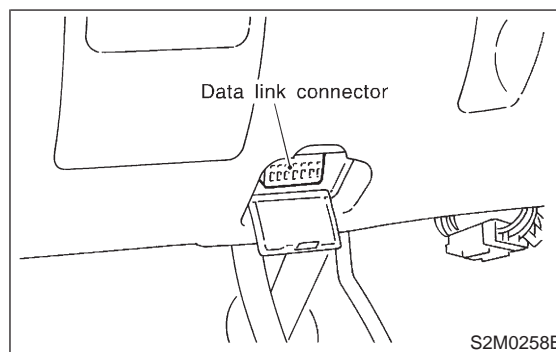

- 4) Turn ignition switch to ON and Subaru Select Monitor or OBD-II general scan tool switch to ON.
- 5) Read data of front oxygen sensor heater current using Subaru Select Monitor or the OBD-II general scan tool.

NOTE:

- Subaru Select Monitor
For detailed operation procedure, refer to the "READ CURRENT DATA SHOWN ON DISPLAY FOR ENGINE". <Ref. to 2-7 [T3C4].>
- OBD-II general scan tool
For detailed operation procedure, refer to the OBD-II General Scan Tool Instruction Manual.

- CHECK** : **Is the value more than 7 A?**
- YES** : Replace ECM. <Ref. to 2-7 [W15A0].>
- NO** : END

ON-BOARD DIAGNOSTICS II SYSTEM

[T11CB5] 2-7

11. Diagnostics Chart with Trouble Code for Except 2200 cc California Spec. Vehicles

11CB4 : CHECK OUTPUT SIGNAL FROM ECM.

Measure voltage between ECM connector and chassis ground.

Connector & terminal
(B134) No. 23 (+) — Chassis ground (-):

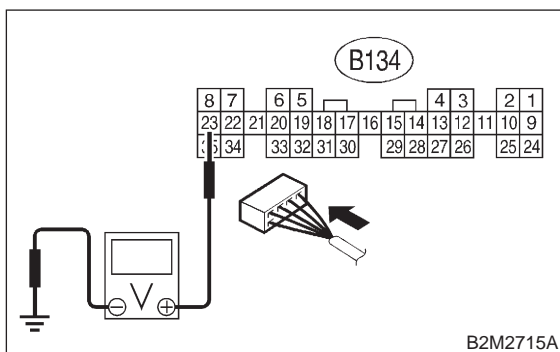

CHECK : Does the voltage change more than 8 V by shaking harness and connector of ECM while monitoring the value with voltage meter?

YES : Repair battery short circuit in harness between ECM and front oxygen sensor connector.

NO : Go to step 11CB5.

11CB5 : CHECK OUTPUT SIGNAL FROM ECM.

Measure voltage between ECM connector and chassis ground.

Connector & terminal
(B134) No. 22 (+) — Chassis ground (-):

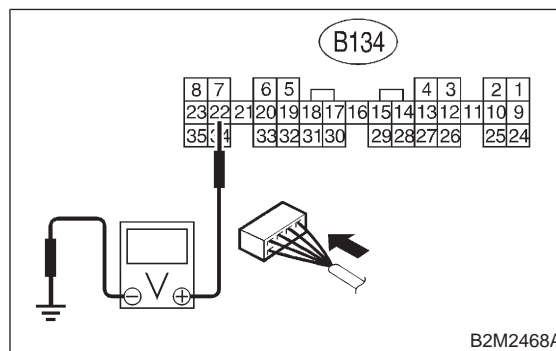

CHECK : Does the voltage change more than 8 V by shaking harness and connector of ECM while monitoring the value with voltage meter?

YES : Repair battery short circuit in harness between ECM and front oxygen sensor connector.

NO : END

2-7 [T11CB5]

ON-BOARD DIAGNOSTICS II SYSTEM

11. Diagnostics Chart with Trouble Code for Except 2200 cc California Spec. Vehicles

MEMO:

CC: DTC P1151 — REAR OXYGEN SENSOR HEATER CIRCUIT HIGH INPUT

- **DTC DETECTING CONDITION:**
 - Two consecutive driving cycles with fault

CAUTION:

After repair or replacement of faulty parts, conduct CLEAR MEMORY MODE <Ref. to 2-7 [T3D0].> and INSPECTION MODE <Ref. to 2-7 [T3E0].>

● **WIRING DIAGRAM:**

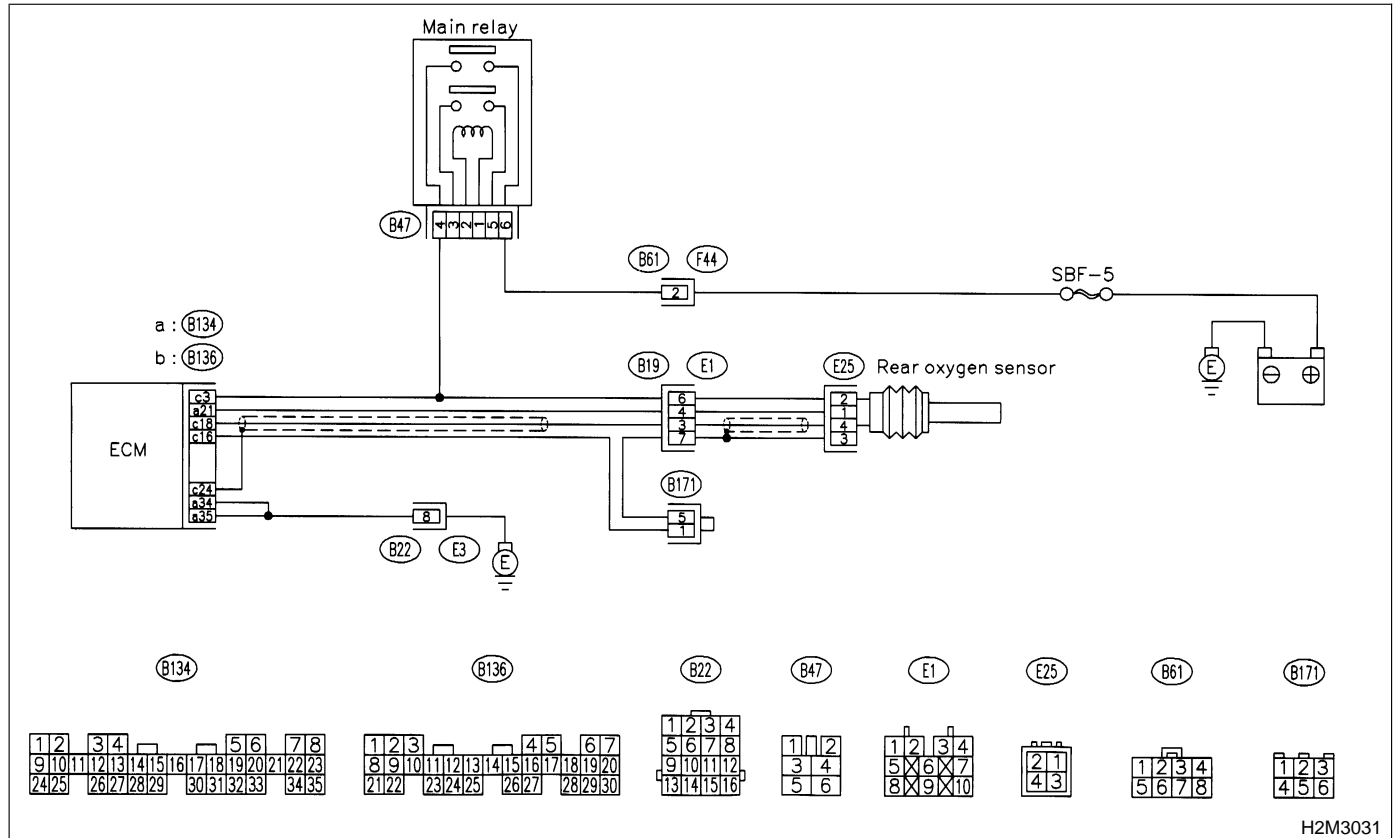

H2M3031

2-7 [T11CC1]

ON-BOARD DIAGNOSTICS II SYSTEM

11. Diagnostics Chart with Trouble Code for Except 2200 cc California Spec. Vehicles

11CC1 : CHECK INPUT SIGNAL FOR ECM.

Measure voltage between ECM connector and chassis ground.

Connector & terminal

(B134) No. 21 (+) — Chassis ground (-):

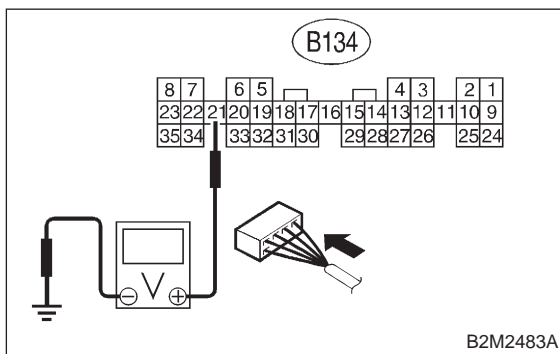

- CHECK** : *Is the voltage more than 8 V?*
YES : Go to step 11CC2.
NO : Go to step 11CC3.

11CC2 : CHECK FRONT OXYGEN SENSOR HEATER CURRENT.

- 1) Turn ignition switch to OFF.
- 2) Repair battery short circuit in harness between ECM and front oxygen sensor connector.
- 3) Connect Subaru Select Monitor or the OBD-II general scan tool to data link connector.

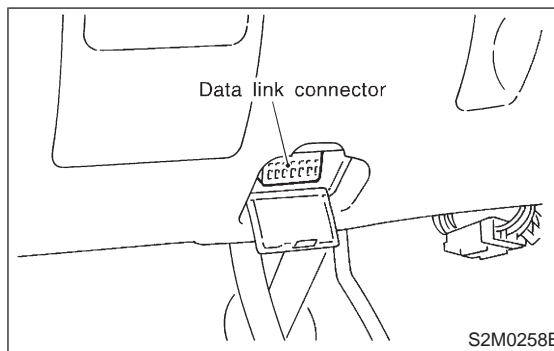

- 4) Turn ignition switch to ON and Subaru Select Monitor or OBD-II general scan tool switch to ON.
- 5) Read data of rear oxygen sensor heater current using Subaru Select Monitor or the OBD-II general scan tool.

NOTE:

- Subaru Select Monitor
For detailed operation procedure, refer to the "READ CURRENT DATA SHOWN ON DISPLAY FOR ENGINE". <Ref. to 2-7 [T3C4].>
- OBD-II general scan tool
For detailed operation procedure, refer to the OBD-II General Scan Tool Instruction Manual.

- CHECK** : *Is the value more than 7 A?*
YES : Replace ECM. <Ref. to 2-7 [W15A0].>
NO : END

11CC3 : CHECK POOR CONTACT.

Check poor contact in ECM connector. <Ref. to FOREWORD [T3C1].>

- CHECK** : *Is there poor contact in ECM connector?*
YES : Repair poor contact in ECM connector.
NO : END.

CD: DTC P1325 — KNOCK SENSOR CIRCUIT LOW INPUT —

- **DTC DETECTING CONDITION:**
 - Immediately at fault recognition
- **TROUBLE SYMPTOM:**
 - Poor driving performance
 - Knocking occurs.

CAUTION:

After repair or replacement of faulty parts, conduct **CLEAR MEMORY MODE** <Ref. to 2-7 [T3D0].> and **INSPECTION MODE** <Ref. to 2-7 [T3E0].>

● **WIRING DIAGRAM:**

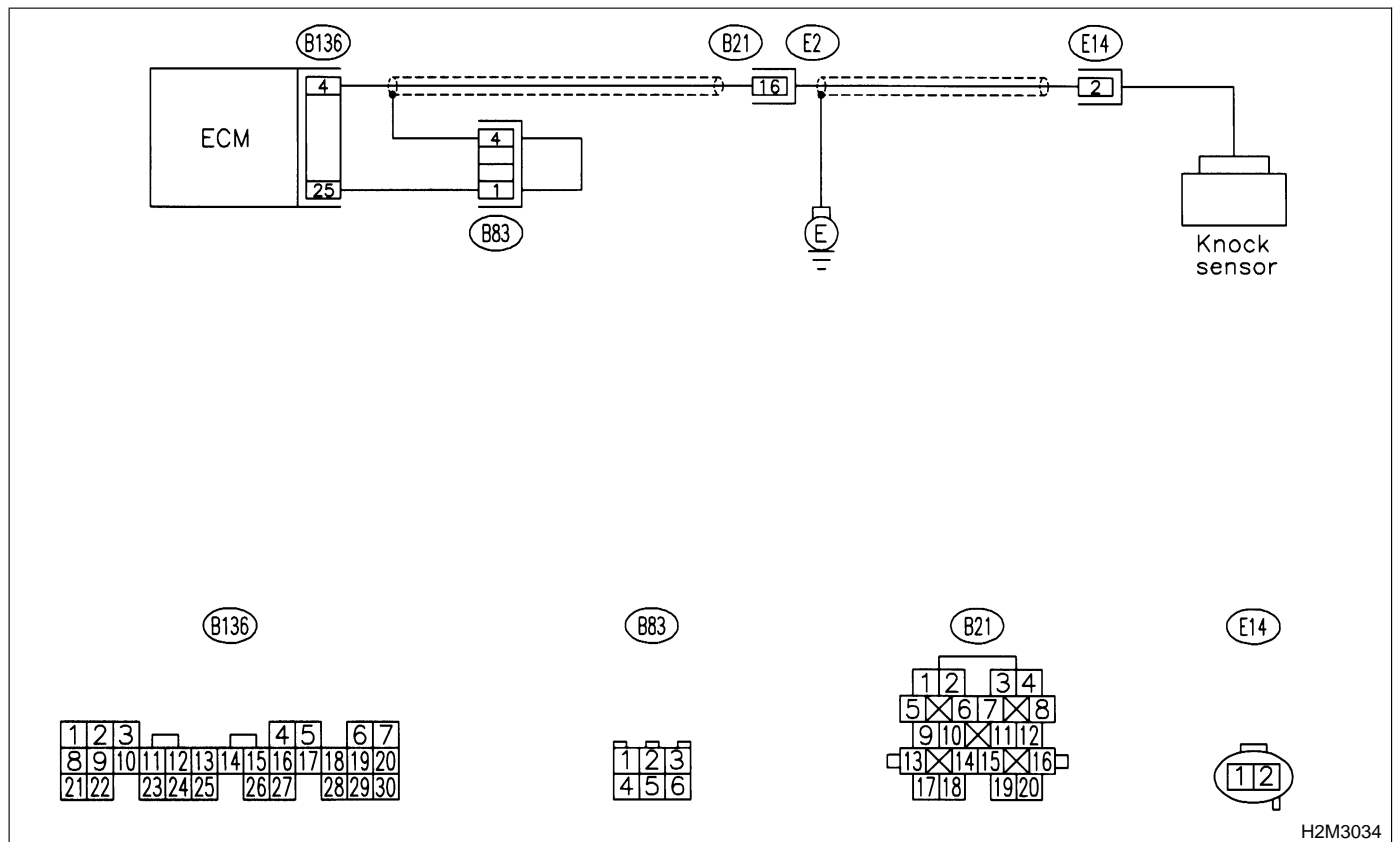

H2M3034

11CD1 : CHECK HARNESS BETWEEN KNOCK SENSOR AND ECM CONNECTOR.

- 1) Turn ignition switch to OFF.
- 2) Disconnect connector from ECM.
- 3) Measure resistance between ECM harness connector and chassis ground.

Connector & terminal
(B136) No. 4 — Chassis ground:

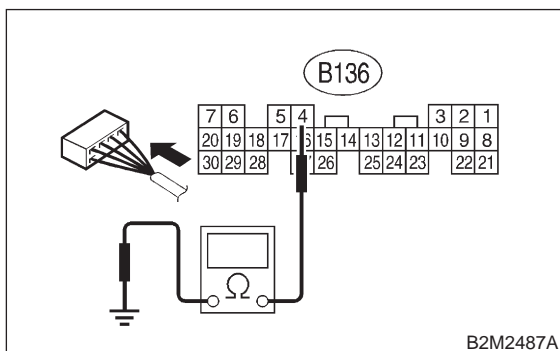

- CHECK** : Is the resistance more than 700 kΩ?
YES : Go to step 11CD3.
NO : Go to step 11CD2.

11CD2 : CHECK HARNESS BETWEEN KNOCK SENSOR AND ECM CONNECTOR.

Measure resistance of harness between ECM connector and chassis ground.

Connector & terminal
(B136) No. 4 — Chassis ground:

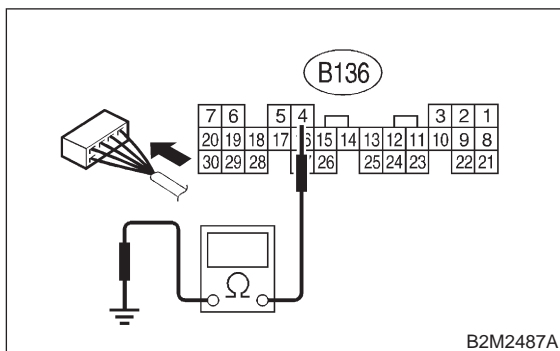

- CHECK** : Is the resistance less than 400 kΩ?
YES : Go to step 11CD5.
NO : Go to step 11CD6.

11CD3 : CHECK KNOCK SENSOR.

- 1) Disconnect connector from knock sensor.
- 2) Measure resistance between knock sensor connector terminal and engine ground.

Terminal
No. 2 — Engine ground:

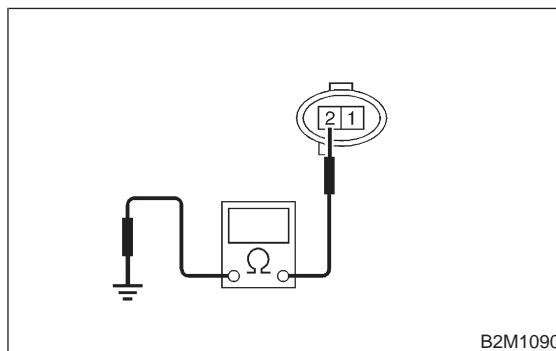

- CHECK** : Is the resistance more than 700 kΩ?
YES : Go to step 11CD4.
NO : Repair harness and connector.

NOTE:

In this case, repair the following:

- Open circuit in harness between knock sensor and ECM connector
- Poor contact in knock sensor connector
- Poor contact in coupling connector (B21)

11CD4 : CHECK CONDITION OF KNOCK SENSOR INSTALLATION.

- CHECK** : Is the knock sensor installation bolt tightened securely?
YES : Replace knock sensor. <Ref. to 2-7 [W19A0].>
NO : Tighten knock sensor installation bolt securely.

11CD5 : CHECK KNOCK SENSOR.

- 1) Disconnect connector from knock sensor.
- 2) Measure resistance between knock sensor connector terminal and engine ground.

Terminal

No. 2 — Engine ground:

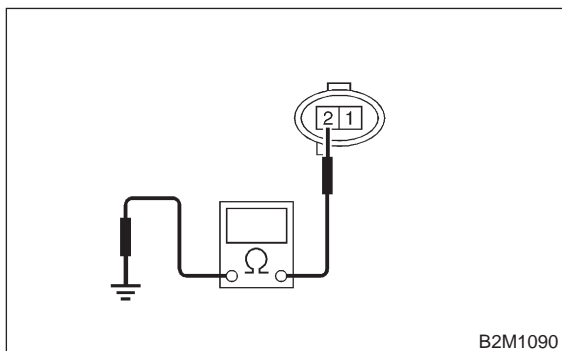

- CHECK** : *Is the resistance less than 400 kΩ?*
- YES** : Replace knock sensor. <Ref. to 2-7 [W19A0].>
- NO** : Repair ground short circuit in harness between knock sensor connector and ECM connector.

NOTE:

The harness between both connectors is shielded. Repair short circuit of harness together with shield.

11CD6 : CHECK INPUT SIGNAL FOR ECM.

- 1) Connect connectors to ECM and knock sensor.
- 2) Turn ignition switch to ON.
- 3) Measure voltage between ECM and chassis ground.

Connector & terminal

(B136) No. 4 (+) — Chassis ground (-):

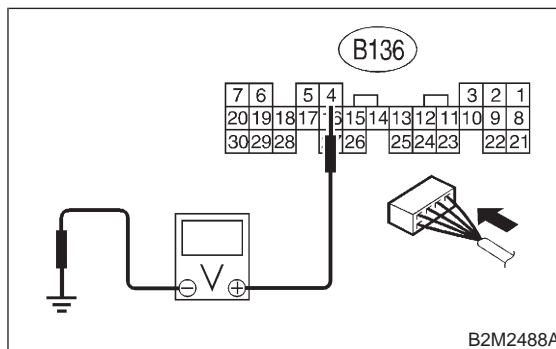

- CHECK** : *Is the voltage more than 2 V?*
- YES** : Even if MIL lights up, the circuit has returned to a normal condition at this time. (However, the possibility of poor contact still remains.)

NOTE:

In this case, repair the following:

- Poor contact in knock sensor connector
- Poor contact in ECM connector
- Poor contact in coupling connector (B21)

- NO** : Repair poor contact in ECM connector.

2-7 [T11CD6]

ON-BOARD DIAGNOSTICS II SYSTEM

11. Diagnostics Chart with Trouble Code for Except 2200 cc California Spec. Vehicles

MEMO:

CE: DTC P1400 — FUEL TANK PRESSURE CONTROL SOLENOID VALVE CIRCUIT LOW INPUT —

- **DTC DETECTING CONDITION:**
 - Two consecutive driving cycles with fault

CAUTION:

After repair or replacement of faulty parts, conduct CLEAR MEMORY MODE <Ref. to 2-7 [T3D0].> and INSPECTION MODE <Ref. to 2-7 [T3E0].>

● **WIRING DIAGRAM:**

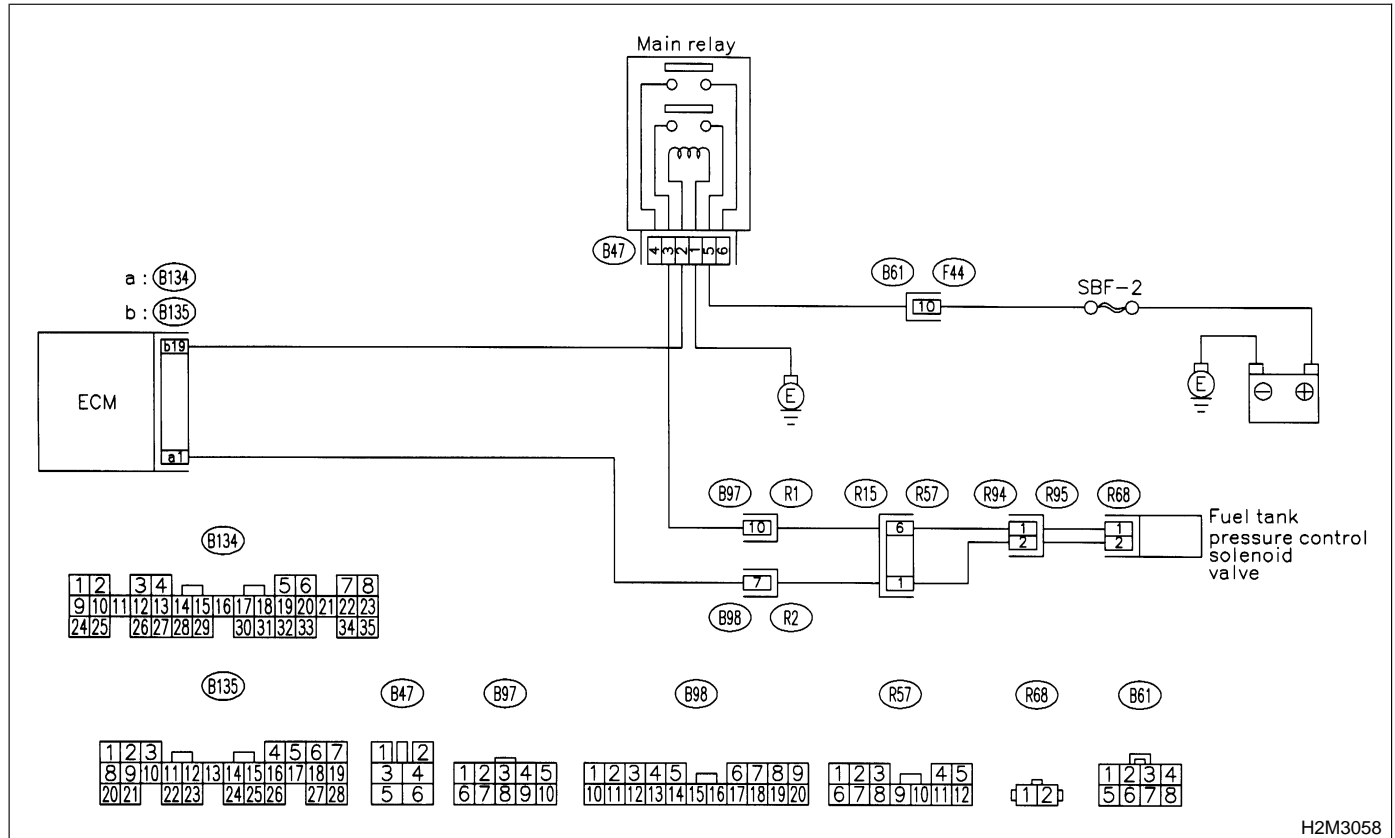

H2M3058

2-7 [T11CE1]

ON-BOARD DIAGNOSTICS II SYSTEM

11. Diagnostics Chart with Trouble Code for Except 2200 cc California Spec. Vehicles

11CE1 : CHECK OUTPUT SIGNAL FROM ECM.

- 1) Turn ignition switch to ON.
- 2) Measure voltage between ECM and chassis ground.

Connector & terminal

(B134) No. 1 (+) — Chassis ground (-):

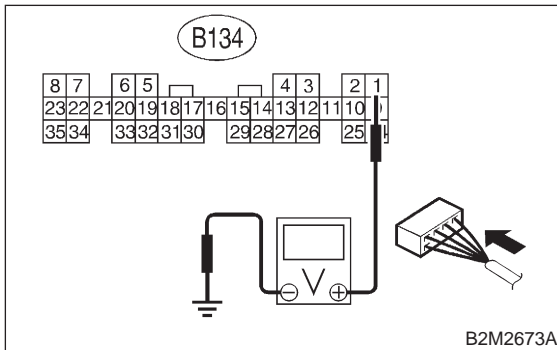

- CHECK** : Is the voltage more than 10 V?
YES : Go to step 11CE2.
NO : Go to step 11CE3.

11CE2 : CHECK POOR CONTACT.

Check poor contact in ECM connector. <Ref. to FOREWORD [T3C1].>

- CHECK** : Is there poor contact in ECM connector?
YES : Repair poor contact in ECM connector.
NO : Contact with SOA service.

NOTE:

Inspection by DTM is required, because probable cause is deterioration of multiple parts.

11CE3 : CHECK HARNESS BETWEEN FUEL TANK PRESSURE CONTROL SOLENOID VALVE AND ECM CONNECTOR.

- 1) Turn ignition switch to OFF.
- 2) Disconnect connectors from fuel tank pressure control solenoid valve and ECM.
- 3) Measure resistance of harness between fuel tank pressure control solenoid valve connector and chassis ground.

Connector & terminal

(R68) No. 2 — Chassis ground:

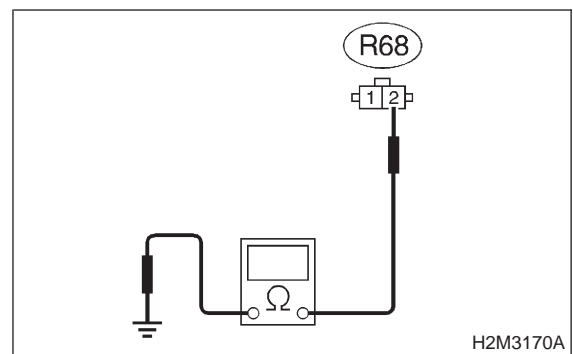

- CHECK** : Is the resistance less than 10 Ω?
YES : Repair ground short circuit in harness between ECM and fuel tank pressure control solenoid valve connector.
NO : Go to step 11CE4.

11CE4 : CHECK HARNESS BETWEEN FUEL TANK PRESSURE CONTROL SOLENOID VALVE AND ECM CONNECTOR.

Measure resistance of harness between ECM and fuel tank pressure control solenoid valve connector.

Connector & terminal

(B134) No. 1 — (R68) No. 2:

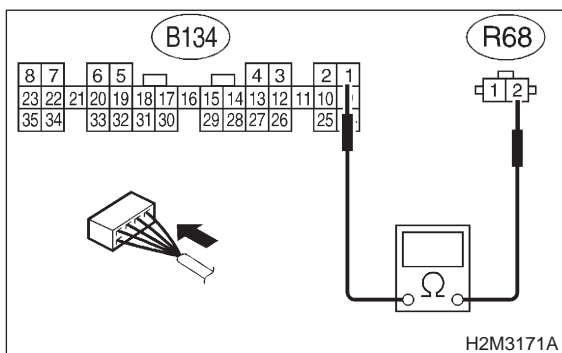

- CHECK** : *Is the resistance less than 1 Ω?*
- YES** : Go to step **11CE5**.
- NO** : Repair harness and connector.

NOTE:

In this case, repair the following:

- Open circuit in harness between ECM and fuel tank pressure control solenoid valve connector
- Poor contact in coupling connectors (R94), (B98) and (R57)

11CE5 : CHECK FUEL TANK PRESSURE CONTROL SOLENOID VALVE.

Measure resistance between fuel tank pressure control solenoid valve terminals.

Terminals

No. 1 — No. 2:

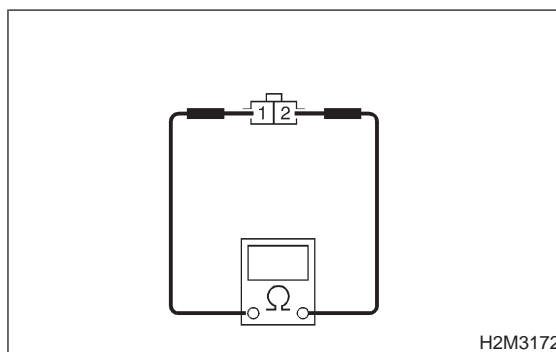

- CHECK** : *Is the resistance between 10 and 100 Ω?*
- YES** : Go to step **11CE6**.
- NO** : Replace fuel tank pressure control solenoid valve. <Ref. to 2-1 [W7A0].>

11CE6 : CHECK POWER SUPPLY TO FUEL TANK PRESSURE CONTROL SOLENOID VALVE.

- 1) Turn ignition switch to ON.
- 2) Measure voltage between fuel tank pressure control solenoid valve and chassis ground.

Connector & terminal

(R68) No. 1 (+) — Chassis ground (-):

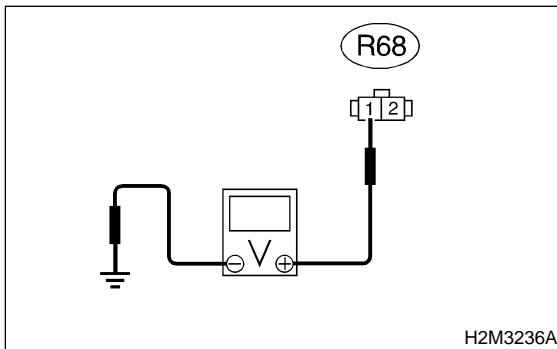

CHECK : **Is the voltage more than 10 V?**

YES : Go to step 11CE7.

NO : Repair harness and connector.

NOTE:

In this case, repair the following:

- Open circuit in harness between main relay and fuel tank pressure control solenoid valve connector
- Poor contact in coupling connectors (R94), (B97) and (R57)
- Poor contact in main relay connector

11CE7 : CHECK POOR CONTACT.

Check poor contact in fuel tank pressure control solenoid valve connector. <Ref. to FOREWORD [T3C1].>

CHECK : **Is there poor contact in fuel tank pressure control solenoid valve connector?**

YES : Repair poor contact in fuel tank pressure control solenoid valve connector.

NO : Contact with SOA service.

NOTE:

Inspection by DTM is required, because probable cause is deterioration of multiple parts.

CF: DTC P1420 — FUEL TANK PRESSURE CONTROL SOLENOID VALVE CIRCUIT HIGH INPUT —

- **DTC DETECTING CONDITION:**
 - Two consecutive driving cycles with fault

CAUTION:

After repair or replacement of faulty parts, conduct CLEAR MEMORY MODE <Ref. to 2-7 [T3D0].> and INSPECTION MODE <Ref. to 2-7 [T3E0].>

● **WIRING DIAGRAM:**

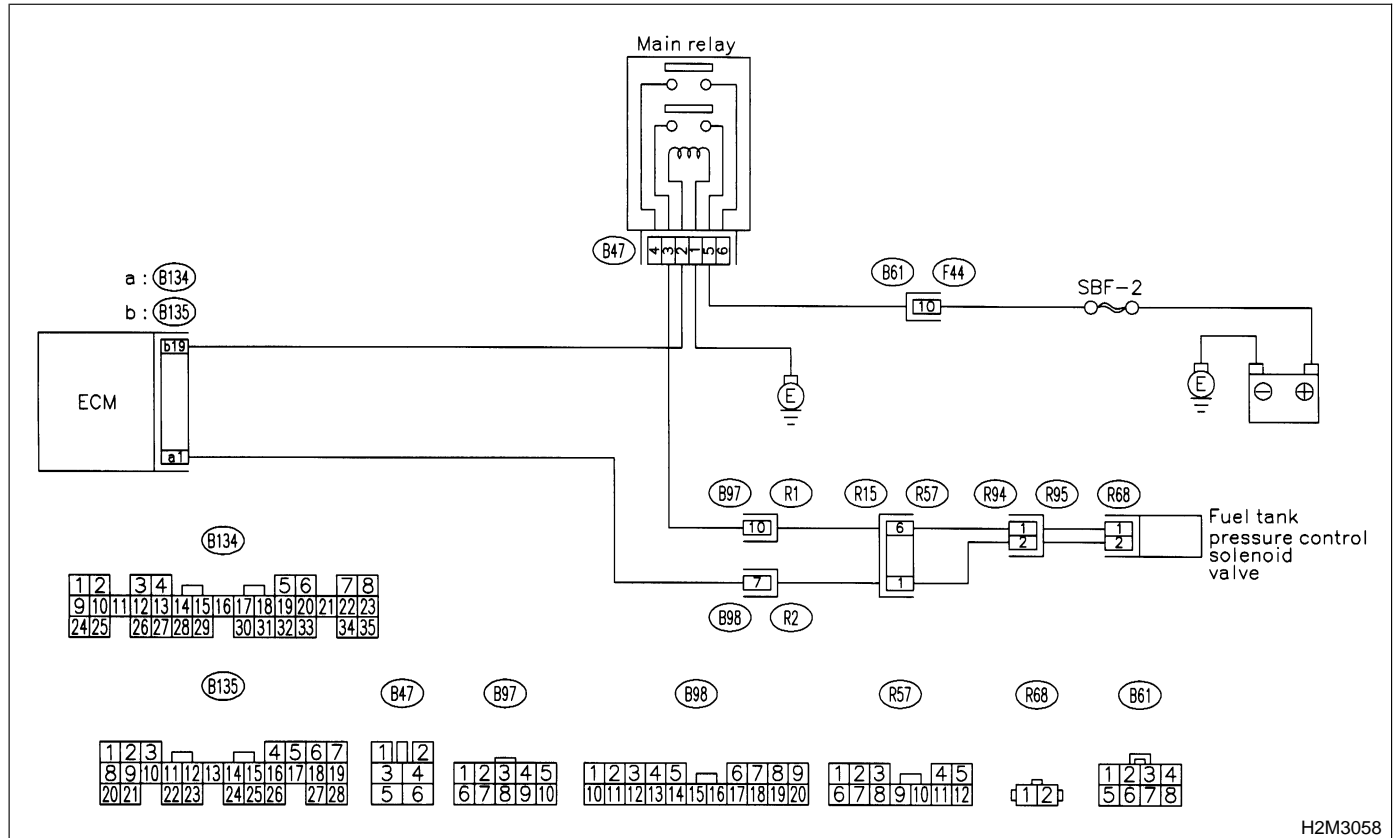

H2M3058

2-7 [T11CF1]

ON-BOARD DIAGNOSTICS II SYSTEM

11. Diagnostics Chart with Trouble Code for Except 2200 cc California Spec. Vehicles

11CF1 : CHECK OUTPUT SIGNAL FROM ECM.

- 1) Turn ignition switch to OFF.
- 2) Connect test mode connector at the lower portion of instrument panel (on the driver's side), to the side of the center console box.

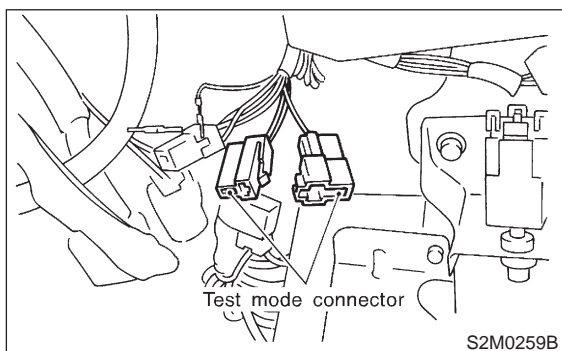

- 3) Turn ignition switch to ON.
- 4) Measure voltage between ECM and chassis ground.

NOTE:

Fuel tank pressure control solenoid valve operation check can be executed using Subaru Select Monitor. For procedure, refer to "COMPULSORY VALVE OPERATION CHECK MODE". <Ref. to 2-7 [T3F0].>

Connector & terminal

(B134) No. 1 (+) — Chassis ground (-):

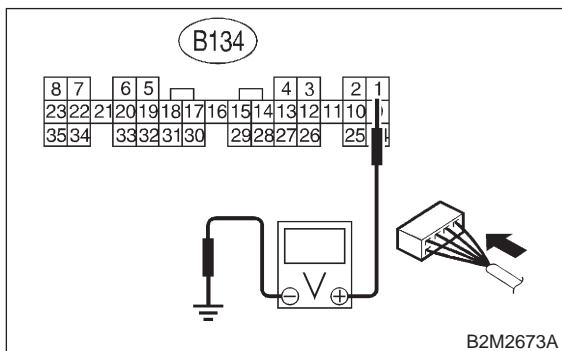

CHECK : Does voltage change between 0 and 10 volts?

YES : Go to step 11CF2.

NO : Even if MIL light up, the circuit has returned to a normal condition at this time. In this case, repair poor contact in ECM connector.

11CF2 : CHECK OUTPUT SIGNAL FROM ECM.

- 1) Turn ignition switch to ON.
- 2) Measure voltage between ECM and chassis ground.

Connector & terminal

(B134) No. 1 (+) — Chassis ground (-):

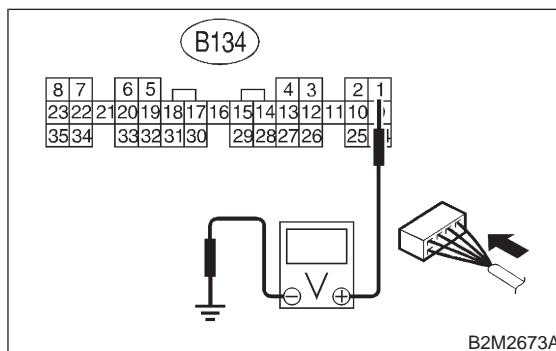

CHECK : Is the voltage more than 10 V?

YES : Go to step 11CF4.

NO : Go to step 11CF3.

11CF3 : CHECK POOR CONTACT.

Check poor contact in ECM connector. <Ref. to FOREWORD [T3C1].>

CHECK : Is there poor contact in ECM connector?

YES : Repair poor contact in ECM connector.

NO : Replace ECM. <Ref. to 2-7 [W15A0].>

11CF4 : CHECK HARNESS BETWEEN FUEL TANK PRESSURE CONTROL SOLENOID VALVE AND ECM CONNECTOR.

- 1) Turn ignition switch to OFF.
- 2) Disconnect connector from fuel tank pressure control solenoid valve.
- 3) Turn ignition switch to ON.
- 4) Measure voltage between ECM and chassis ground.

Connector & terminal

(B134) No. 1 (+) — Chassis ground (-):

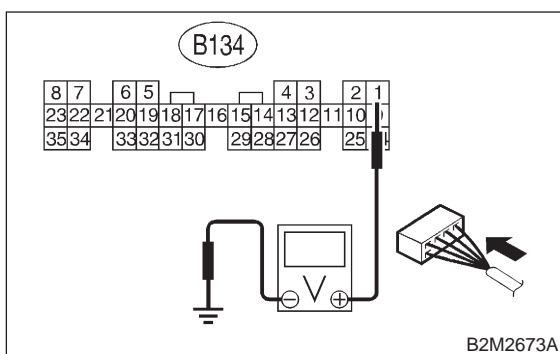

- CHECK** : **Is the voltage more than 10 V?**
- YES** : Repair battery short circuit in harness between ECM and fuel tank pressure control solenoid valve connector. After repair, replace ECM. <Ref. to 2-7 [W15A0].>
- NO** : Go to step 11CF5.

11CF5 : CHECK FUEL TANK PRESSURE CONTROL SOLENOID VALVE.

- 1) Turn ignition switch to OFF.
- 2) Measure resistance between fuel tank pressure control solenoid valve terminals.

Terminals

No. 1 — No. 2:

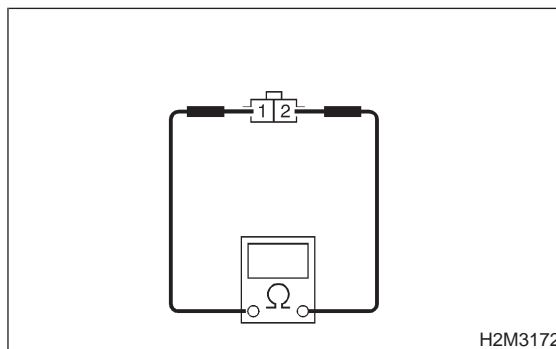

- CHECK** : **Is the resistance less than 1 Ω?**
- YES** : Replace fuel tank pressure control solenoid valve <Ref. to 2-1 [W7A0].> and ECM <Ref. to 2-7 [W15A0].>.
- NO** : Go to step 11CF6.

11CF6 : CHECK POOR CONTACT.

Check poor contact in ECM connector. <Ref. to FOREWORD [T3C1].>

- CHECK** : **Is there poor contact in ECM connector?**
- YES** : Repair poor contact in ECM connector.
- NO** : Replace ECM. <Ref. to 2-7 [W15A0].>

2-7 [T11CF6]

ON-BOARD DIAGNOSTICS II SYSTEM

11. Diagnostics Chart with Trouble Code for Except 2200 cc California Spec. Vehicles

MEMO:

CG: DTC P1422 — EVAPORATIVE EMISSION CONTROL SYSTEM PURGE CONTROL VALVE CIRCUIT HIGH INPUT —

- **DTC DETECTING CONDITION:**
 - Two consecutive driving cycles with fault
- **TROUBLE SYMPTOM:**
 - Erroneous idling

CAUTION:

After repair or replacement of faulty parts, conduct CLEAR MEMORY MODE <Ref. to 2-7 [T3D0].> and INSPECTION MODE <Ref. to 2-7 [T3E0].>

● **WIRING DIAGRAM:**

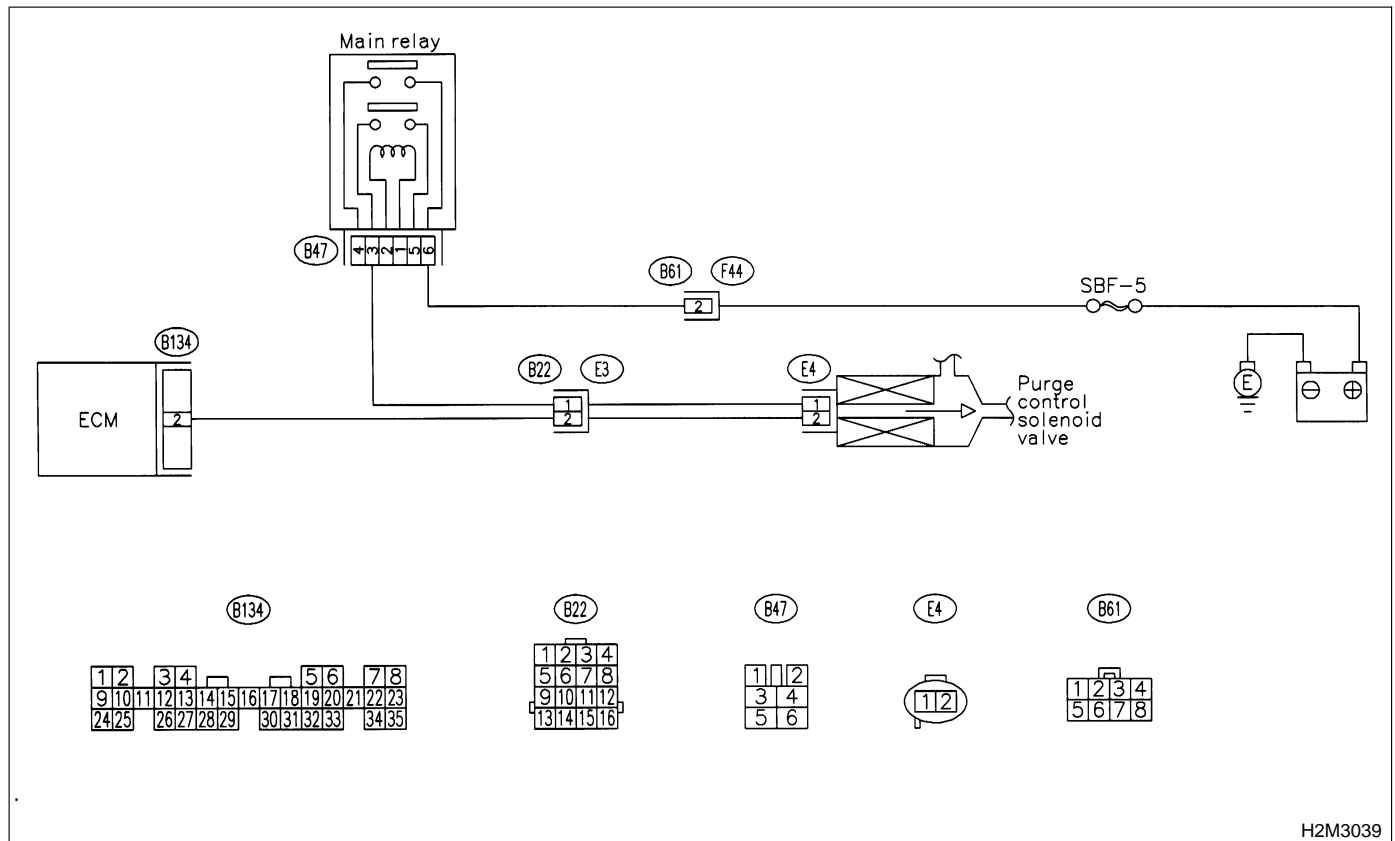

H2M3039

11CG1 : CHECK OUTPUT SIGNAL FROM ECM.

- 1) Turn ignition switch to OFF.
- 2) Connect test mode connector at the lower portion of instrument panel (on the driver's side), to the side of the center console box.

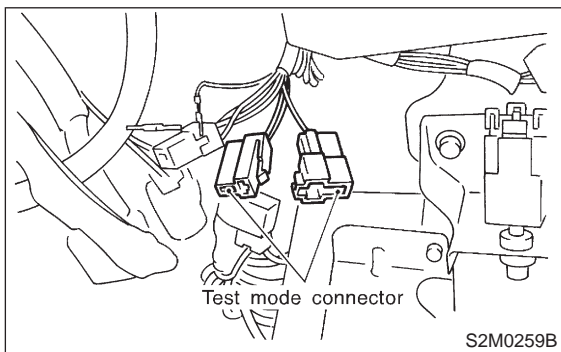

- 3) Turn ignition switch to ON.
- 4) Measure voltage between ECM and chassis ground.

NOTE:

Purge control solenoid valve operation check can be executed using Subaru Select Monitor. For procedure, refer to "COMPULSORY VALVE OPERATION CHECK MODE". <Ref. to 2-7 [T3F0].>

Connector & terminal

(B134) No. 2 (+) — Chassis ground (-):

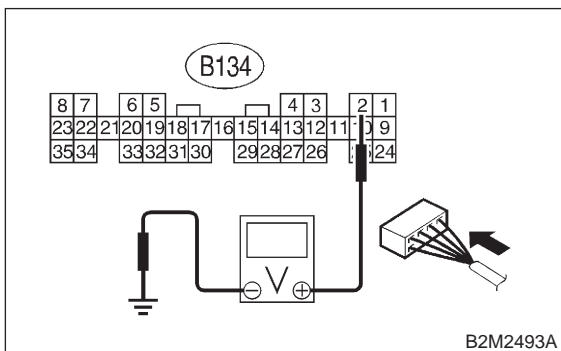

- CHECK** : Does voltage change between 0 and 10 volts?
- YES** : Go to step 11CG2.
- NO** : Even if MIL light up, the circuit has returned to a normal condition at this time. In this case, repair poor contact in ECM connector.

11CG2 : CHECK OUTPUT SIGNAL FROM ECM.

- 1) Turn ignition switch to ON.
- 2) Measure voltage between ECM and chassis ground.

Connector & terminal

(B134) No. 2 (+) — Chassis ground (-):

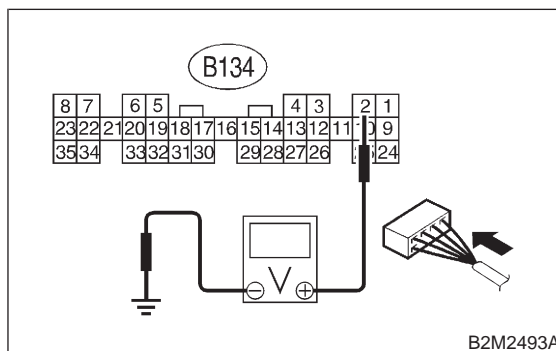

- CHECK** : Is the voltage more than 10 V?
- YES** : Go to step 11CG4.
- NO** : Go to step 11CG3.

11CG3 : CHECK POOR CONTACT.

Check poor contact in ECM connector. <Ref. to FOREWORD [T3C1].>

- CHECK** : Is there poor contact in ECM connector?
- YES** : Repair poor contact in ECM connector.
- NO** : Replace ECM. <Ref. to 2-7 [W15A0].>

11CG4 : CHECK HARNESS BETWEEN PURGE CONTROL SOLENOID VALVE AND ECM CONNECTOR.

- 1) Turn ignition switch to OFF.
- 2) Disconnect connector from purge control solenoid valve.
- 3) Turn ignition switch to ON.
- 4) Measure voltage between ECM and chassis ground.

Connector & terminal

(B134) No. 2 (+) — Chassis ground (-):

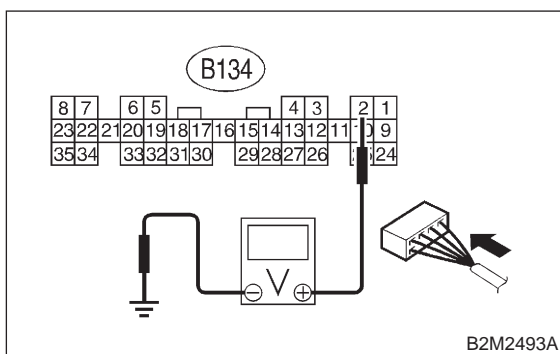

- CHECK** : **Is the voltage more than 10 V?**
- YES** : Repair battery short circuit in harness between ECM and purge control solenoid valve connector. After repair, replace ECM. <Ref. to 2-7 [W15A0].>
- NO** : Go to step **11CG5**.

11CG5 : CHECK PURGE CONTROL SOLENOID VALVE.

- 1) Turn ignition switch to OFF.
- 2) Measure resistance between purge control solenoid valve terminals.

Terminals

No. 1 — No. 2:

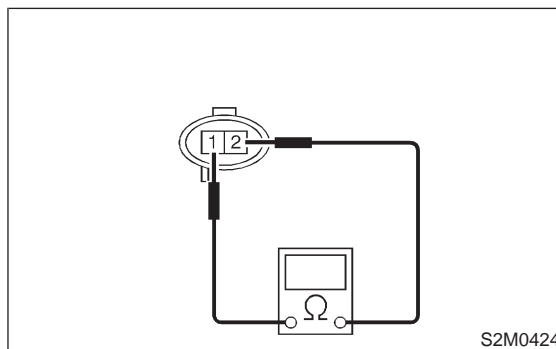

- CHECK** : **Is the resistance less than 1 Ω?**
- YES** : Replace purge control solenoid valve <Ref. to 2-1 [W4A0].> and ECM <Ref. to 2-7 [W15A0].>.
- NO** : Go to step **11CG6**.

11CG6 : CHECK POOR CONTACT.

Check poor contact in ECM connector. <Ref. to FOREWORD [T3C1].>

- CHECK** : **Is there poor contact in ECM connector?**
- YES** : Repair poor contact in ECM connector.
- NO** : Replace ECM. <Ref. to 2-7 [W15A0].>

MEMO:

CH: DTC P1423 — EVAPORATIVE EMISSION CONTROL SYSTEM VENT CONTROL HIGH INPUT —

- **DTC DETECTING CONDITION:**
 - Two consecutive driving cycles with fault

CAUTION:

After repair or replacement of faulty parts, conduct **CLEAR MEMORY MODE** <Ref. to 2-7 [T3D0].> and **INSPECTION MODE** <Ref. to 2-7 [T3E0].>

● **WIRING DIAGRAM:**

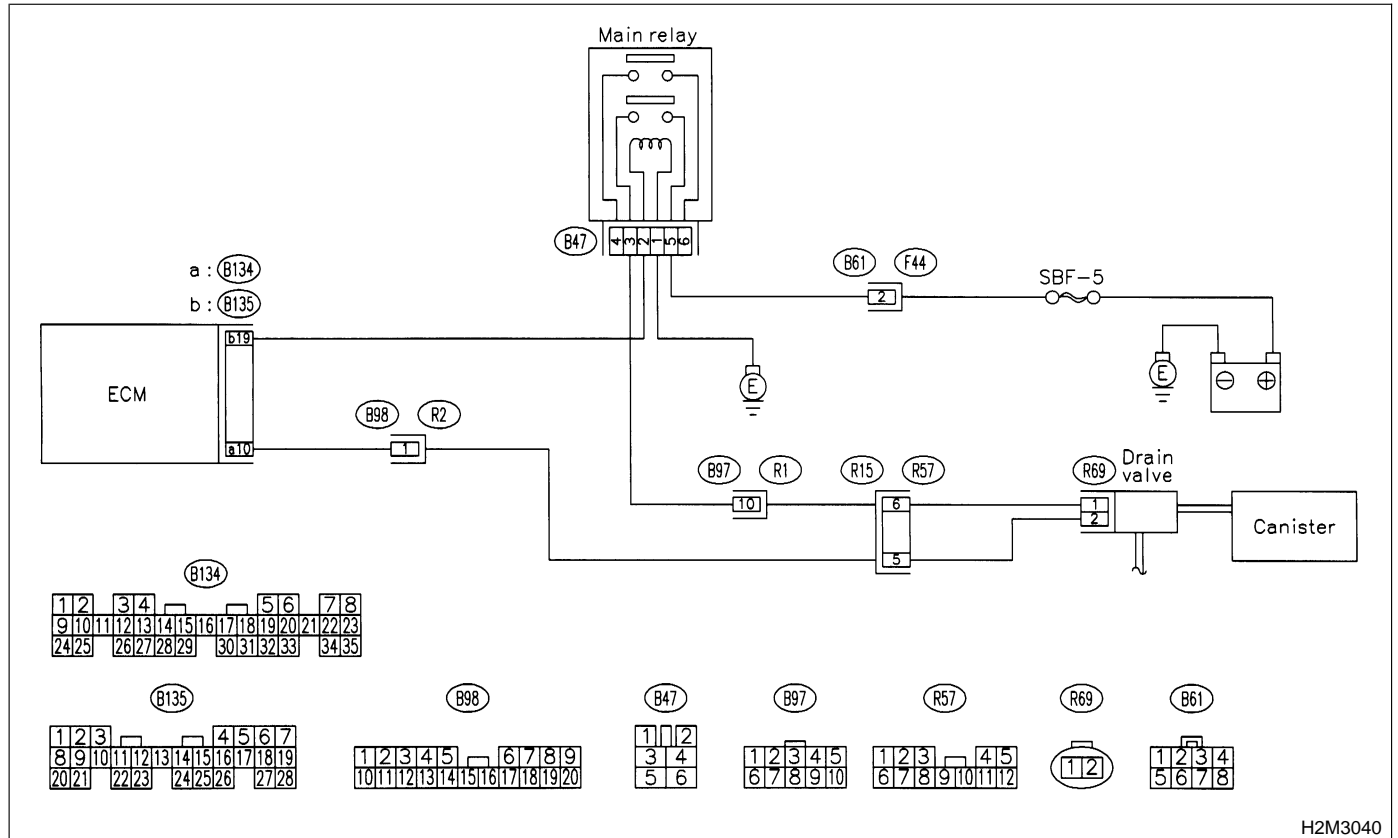

H2M3040

2-7 [T11CH1]

ON-BOARD DIAGNOSTICS II SYSTEM

11. Diagnostics Chart with Trouble Code for Except 2200 cc California Spec. Vehicles

11CH1 : CHECK OUTPUT SIGNAL FROM ECM.

- 1) Turn ignition switch to OFF.
- 2) Connect test mode connector at the lower portion of instrument panel (on the driver's side), to the side of the center console box.

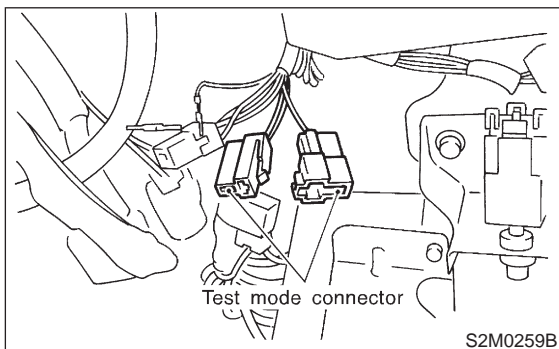

- 3) Turn ignition switch to ON.
- 4) Measure voltage between ECM and chassis ground.

NOTE:

Drain valve operation check can be executed using Subaru Select Monitor. For procedure, refer to "COMPULSORY VALVE OPERATION CHECK MODE". <Ref. to 2-7 [T3F0].>

Connector & terminal

(B134) No. 10 (+) — Chassis ground (-):

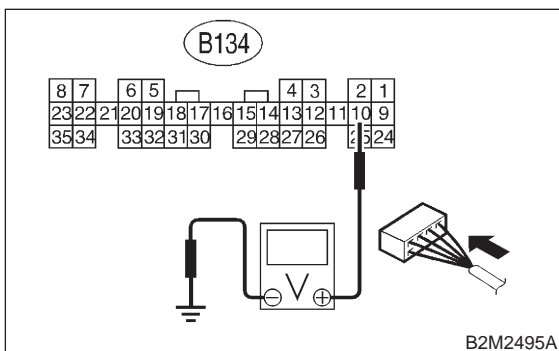

CHECK : Does voltage change between 0 and 10 volts?

YES : Go to step 11CH2.

NO : Even if MIL light up, the circuit has returned to a normal condition at this time. In this case, repair poor contact in ECM connector.

11CH2 : CHECK OUTPUT SIGNAL FROM ECM.

- 1) Turn ignition switch to ON.
- 2) Measure voltage between ECM and chassis ground.

Connector & terminal

(B134) No. 10 (+) — Chassis ground (-):

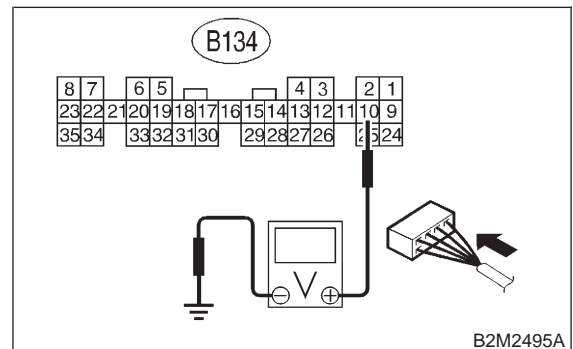

CHECK : Is the voltage more than 10 V?

YES : Go to step 11CH4.

NO : Go to step 11CH3.

11CH3 : CHECK POOR CONTACT.

Check poor contact in ECM connector. <Ref. to FOREWORD [T3C1].>

CHECK : Is there poor contact in ECM connector?

YES : Repair poor contact in ECM connector.

NO : Replace ECM. <Ref. to 2-7 [W15A0].>

11CH4 : CHECK HARNESS BETWEEN DRAIN VALVE AND ECM CONNECTOR.

- 1) Turn ignition switch to OFF.
- 2) Disconnect connector from drain valve.
- 3) Turn ignition switch to ON.
- 4) Measure voltage between ECM and chassis ground.

Connector & terminal

(B134) No. 10 (+) — Chassis ground (-):

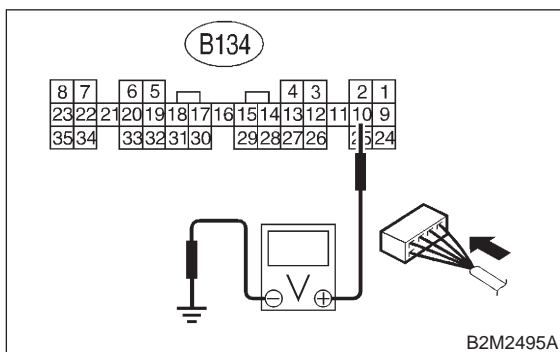

- CHECK** : **Is the voltage more than 10 V?**
- YES** : Repair battery short circuit in harness between ECM and drain valve connector. After repair, replace ECM. <Ref. to 2-7 [W15A0].>
- NO** : Go to step **11CH5**.

11CH5 : CHECK DRAIN VALVE.

- 1) Turn ignition switch to OFF.
- 2) Measure resistance between drain valve terminals.

Terminals

No. 1 — No. 2:

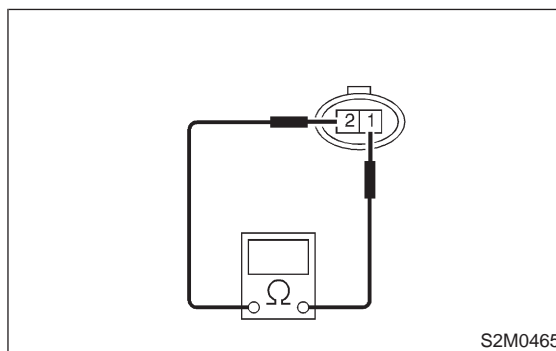

- CHECK** : **Is the resistance less than 1 Ω?**
- YES** : Replace drain valve <Ref. to 2-1 [W13A0].> and ECM <Ref. to 2-7 [W15A0].>.
- NO** : Go to step **11CH6**.

11CH6 : CHECK POOR CONTACT.

Check poor contact in ECM connector. <Ref. to FOREWORD [T3C1].>

- CHECK** : **Is there poor contact in ECM connector?**
- YES** : Repair poor contact in ECM connector.
- NO** : Replace ECM. <Ref. to 2-7 [W15A0].>

CI: DTC P1442 — FUEL LEVEL SENSOR CIRCUIT RANGE/PERFORMANCE PROBLEM 2 —

● DTC DETECTING CONDITION:

- Two consecutive driving cycles with fault

CAUTION:

After repair or replacement of faulty parts, conduct CLEAR MEMORY MODE <Ref. to 2-7 [T3D0].> and INSPECTION MODE <Ref. to 2-7 [T3E0].>

● WIRING DIAGRAM:

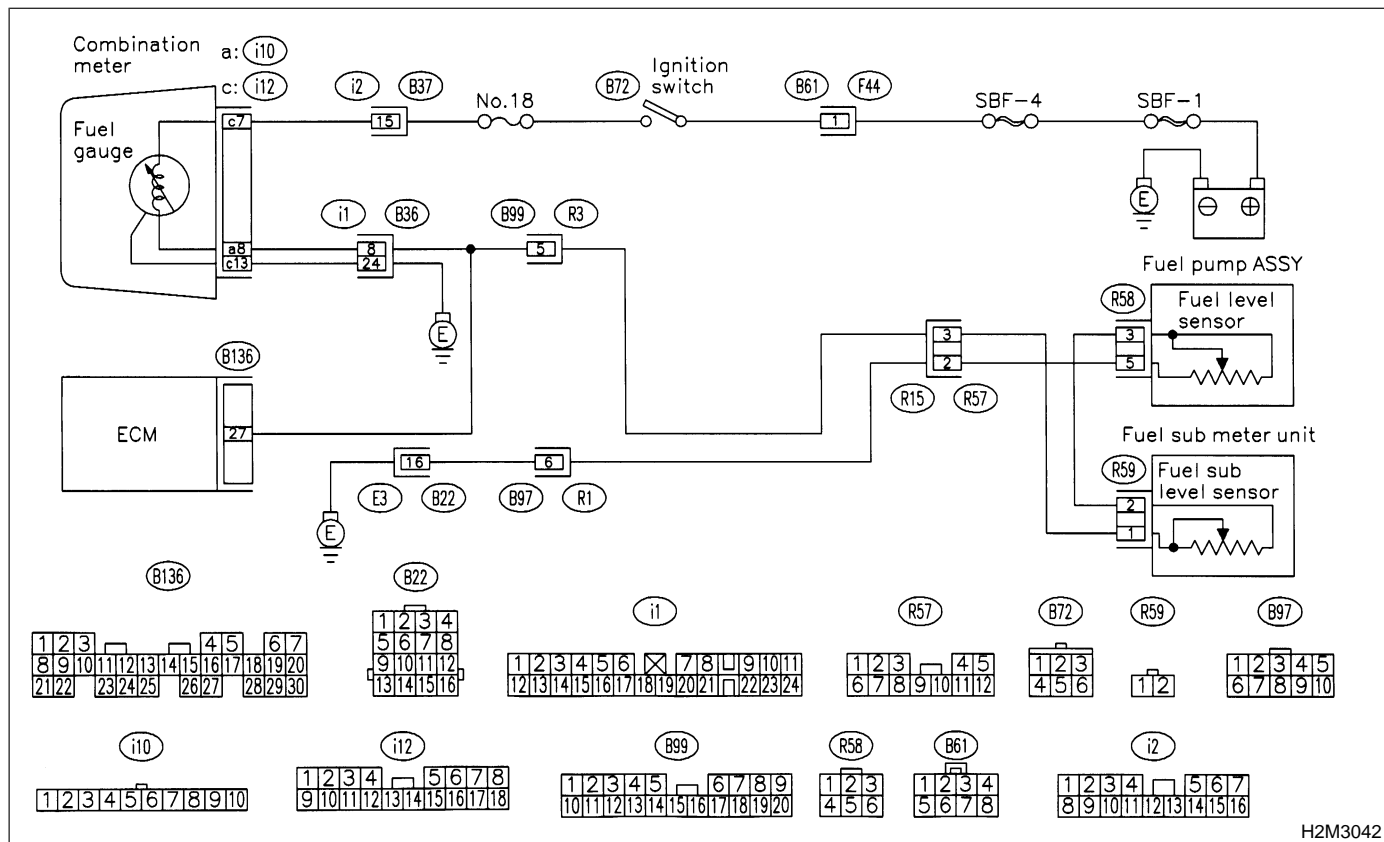

H2M3042

11C11 : CHECK ANY OTHER DTC ON DISPLAY.

- CHECK** : Does the Subaru Select Monitor or OBD-II general scan tool indicate DTC P0461, P0462 or P0463?
- YES** : Inspect DTC P0461, P0462 or P0463 using "11. Diagnostics Chart with Trouble Code for Except 2200 cc California Spec. Vehicles". <Ref. to 2-7 [T11A0].>

NOTE:
In this case, it is not necessary to inspect this trouble.

- NO** : Replace fuel sending unit <Ref. to 2-1 [W8A0].> and fuel sub meter unit.

CJ: DTC P1443 — EVAPORATIVE EMISSION CONTROL SYSTEM VENT CONTROL FUNCTION PROBLEM —

- **DTC DETECTING CONDITION:**
 - Immediately after fault occurrence
- **TROUBLE SYMPTOM:**
 - Improper fuel supply

CAUTION:

After repair or replacement of faulty parts, conduct **CLEAR MEMORY MODE** <Ref. to 2-7 [T3D0].> and **INSPECTION MODE** <Ref. to 2-7 [T3E0].>

● **WIRING DIAGRAM:**

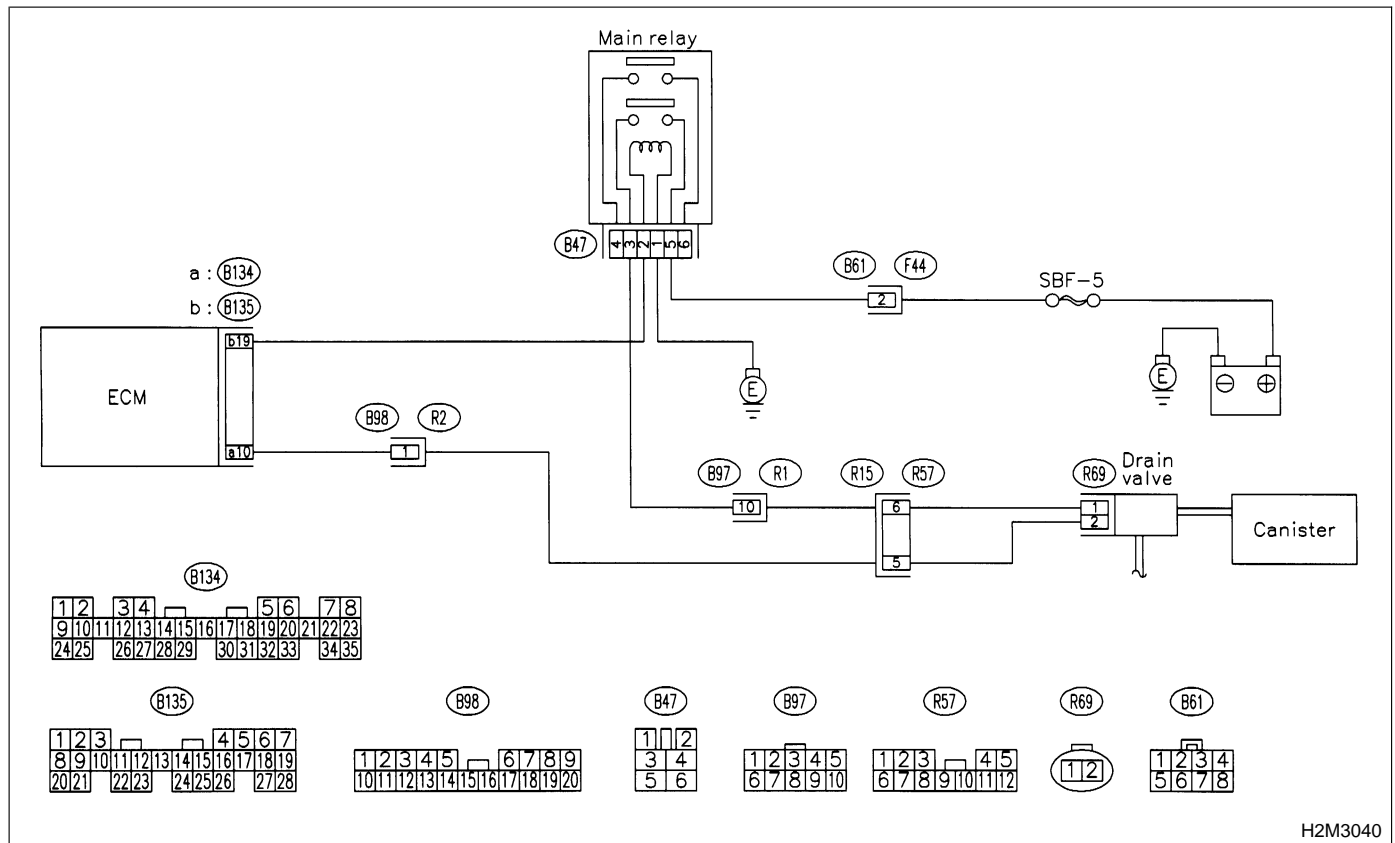

H2M3040

11CJ1 : CHECK ANY OTHER DTC ON DISPLAY.

- CHECK** : *Is there any other DTC on display?*
- YES** : Inspect the relevant DTC using “11. Diagnostics Chart with Trouble Code for Except 2200 cc California Spec. Vehicles”. <Ref. to 2-7 [T11A0].>
- NO** : Go to step **11CJ2**.

2-7 [T11CJ2]

ON-BOARD DIAGNOSTICS II SYSTEM

11. Diagnostics Chart with Trouble Code for Except 2200 cc California Spec. Vehicles

11CJ2 : CHECK VENT LINE HOSES.

Check the following items.

- Clogging of vent hoses between canister and drain valve
- Clogging of vent hose between drain valve and air filter
- Clogging of vent hose between air filter and junction pipe
- Clogging of junction pipe
- Clogging of air filter

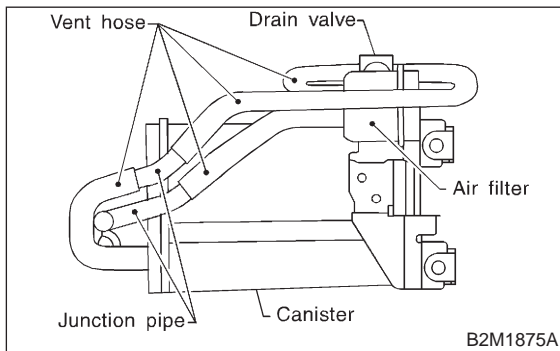

- CHECK** : **Is there a fault in vent line?**
YES : Repair or replace the faulty part.
NO : Go to step 11CJ3.

11CJ3 : CHECK DRAIN VALVE OPERATION.

- 1) Turn ignition switch to OFF.
- 2) Connect test mode connector at the lower portion of instrument panel (on the driver's side), to the side of the center console box.

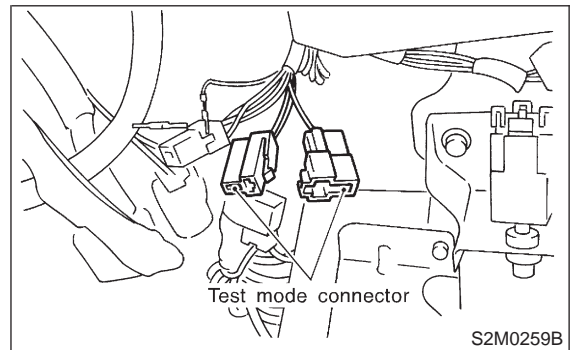

- 3) Turn ignition switch to ON.

NOTE:

Drain valve operation check can also be executed using Subaru Select Monitor. For the procedure, refer to the "COMPULSORY VALVE OPERATION CHECK MODE". <Ref. to 2-7 [T3F0].>

- CHECK** : **Does drain valve produce operating sound?**
YES : Contact with SOA service.

NOTE:

Inspection by DTM is required, because probable cause is deterioration of multiple parts.

- NO** : Replace drain valve. <Ref. to 2-1 [W13A0].>

CK: DTC P1507 — IDLE CONTROL SYSTEM MALFUNCTION (FAIL-SAFE) —

• DTC DETECTING CONDITION:

- Two consecutive driving cycles with fault

• TROUBLE SYMPTOM:

- Engine keeps running at higher revolution than specified idling revolution.

CAUTION:

After repair or replacement of faulty parts, conduct CLEAR MEMORY MODE <Ref. to 2-7 [T3D0].> and INSPECTION MODE <Ref. to 2-7 [T3E0].>

• WIRING DIAGRAM:

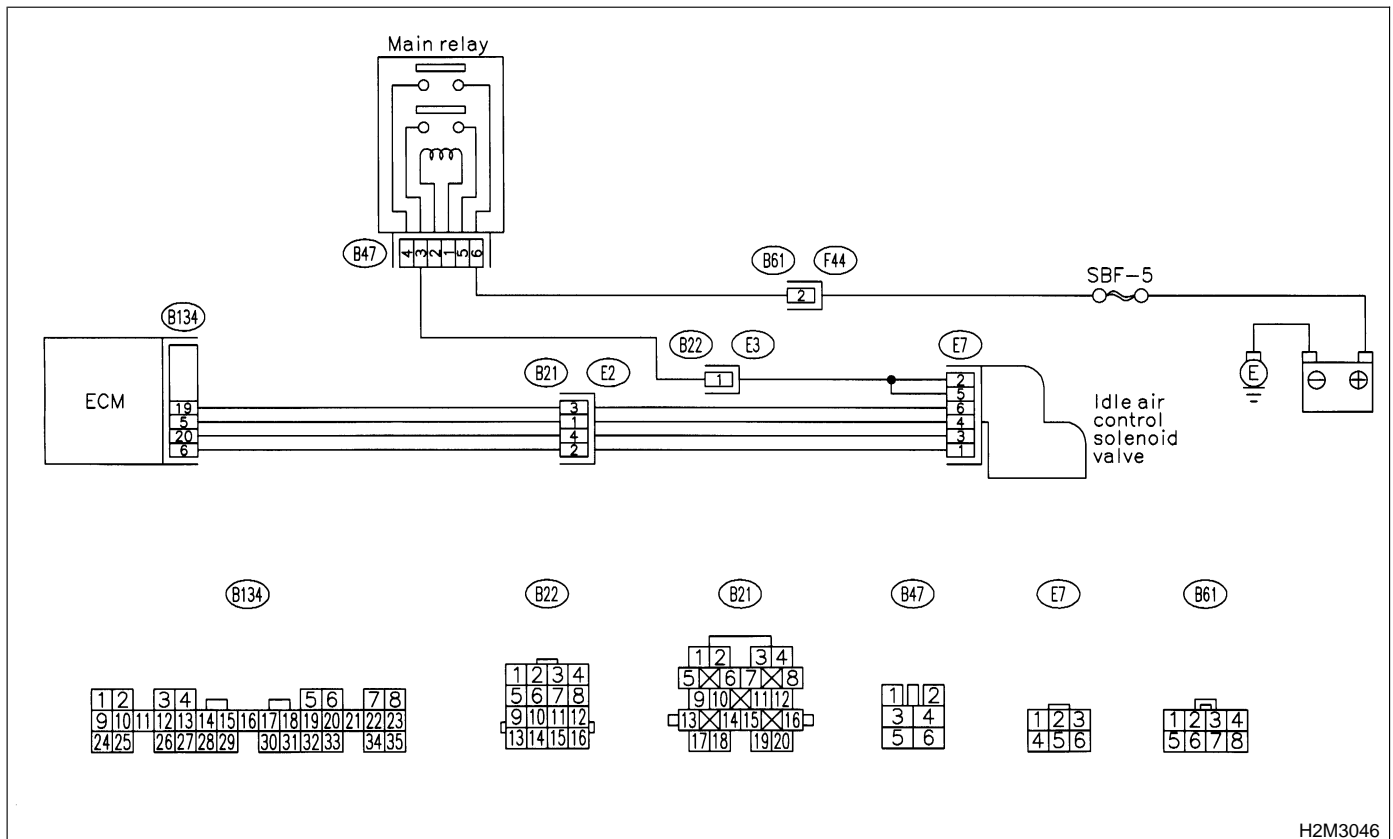

H2M3046

11CK1 : CHECK ANY OTHER DTC ON DISPLAY.

CHECK : Does the Subaru Select Monitor or OBD-II general scan tool indicate DTC P0116 or P0117 or P0505 or P1505?

YES : Inspect DTC P0116 or P0117 or P0505 or P1505 using "11. Diagnostics Chart with Trouble Code for Except 2200 cc California Spec. Vehicles". <Ref. to 2-7 [T11A0].>

NOTE:
In this case, it is not necessary to inspect DTC P1507.

NO : Go to step **11CK2**.

11CK2 : CHECK AIR INTAKE SYSTEM.

- 1) Turn ignition switch to ON.
- 2) Start engine, and idle it.
- 3) Check the following items.
 - Loose installation of intake manifold, idle air control solenoid valve and throttle body
 - Cracks of intake manifold gasket, idle air control solenoid valve gasket and throttle body gasket
 - Disconnections of vacuum hoses

CHECK : Is there a fault in air intake system?

YES : Repair air suction and leaks.

NO : Replace idle air control solenoid valve. <Ref. to 2-7 [W12A2].>

2-7 [T11CK2]

ON-BOARD DIAGNOSTICS II SYSTEM

11. Diagnostics Chart with Trouble Code for Except 2200 cc California Spec. Vehicles

MEMO:

**CL: DTC P1510 — IDLE AIR CONTROL SOLENOID VALVE SIGNAL 1
CIRCUIT LOW INPUT —****NOTE:**

For the diagnostic procedure, refer to 2-7 [T11CR0]. <Ref. to 2-7 [T11CR0].>

**CM: DTC P1511 — IDLE AIR CONTROL SOLENOID VALVE SIGNAL 1
CIRCUIT HIGH INPUT —****NOTE:**

For the diagnostic procedure, refer to 2-7 [T11CS0]. <Ref. to 2-7 [T11CS0].>

**CN: DTC P1512 — IDLE AIR CONTROL SOLENOID VALVE SIGNAL 2
CIRCUIT LOW INPUT —****NOTE:**

For the diagnostic procedure, refer to 2-7 [T11CR0]. <Ref. to 2-7 [T11CR0].>

**CO: DTC P1513 — IDLE AIR CONTROL SOLENOID VALVE SIGNAL 2
CIRCUIT HIGH INPUT —****NOTE:**

For the diagnostic procedure, refer to 2-7 [T11CR0]. <Ref. to 2-7 [T11CR0].>

**CP: DTC P1514 — IDLE AIR CONTROL SOLENOID VALVE SIGNAL 3
CIRCUIT LOW INPUT —****NOTE:**

For the diagnostic procedure, refer to 2-7 [T11CR0]. <Ref. to 2-7 [T11CR0].>

**CQ: DTC P1515 — IDLE AIR CONTROL SOLENOID VALVE SIGNAL 3
CIRCUIT HIGH INPUT —****NOTE:**

For the diagnostic procedure, refer to 2-7 [T11CR0]. <Ref. to 2-7 [T11CR0].>

CR: DTC P1516 — IDLE AIR CONTROL SOLENOID VALVE SIGNAL 4 CIRCUIT LOW INPUT —

- **DTC DETECTING CONDITION:**
 - Immediately at fault recognition
- **TROUBLE SYMPTOM:**
 - Erroneous idling
 - Engine stalls.
 - Engine breathing

CAUTION:

After repair or replacement of faulty parts, conduct CLEAR MEMORY MODE <Ref. to 2-7 [T3D0].> and INSPECTION MODE <Ref. to 2-7 [T3E0].>

● **WIRING DIAGRAM:**

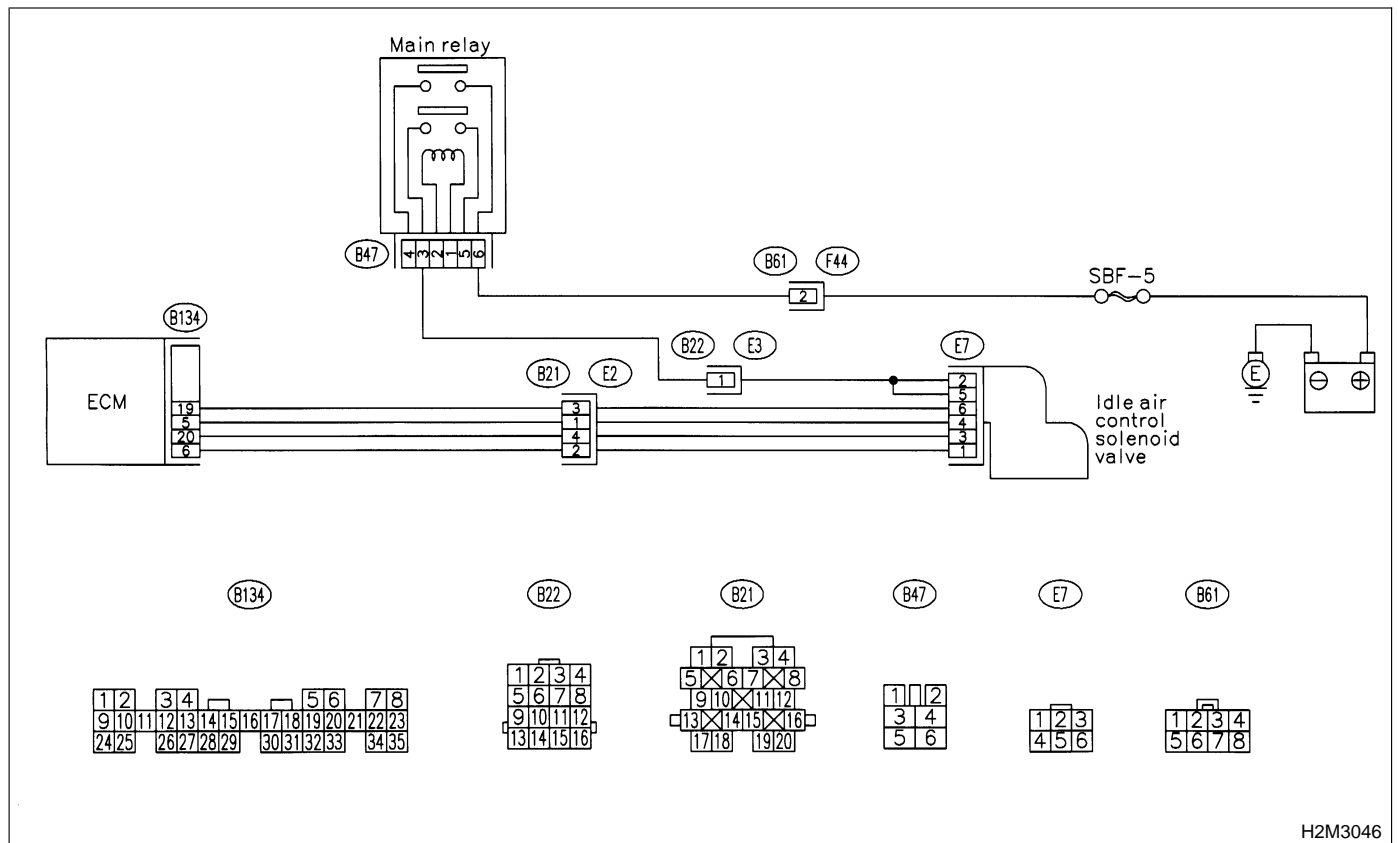

11CR1 : CHECK POWER SUPPLY TO IDLE AIR CONTROL SOLENOID VALVE.

- 1) Turn ignition switch to OFF.
- 2) Disconnect connector from idle air control solenoid valve.
- 3) Turn ignition switch to ON.
- 4) Measure voltage between idle air control solenoid valve connector and engine ground.

Connector & terminal

(E7) No. 2 (+) — Engine ground (-):

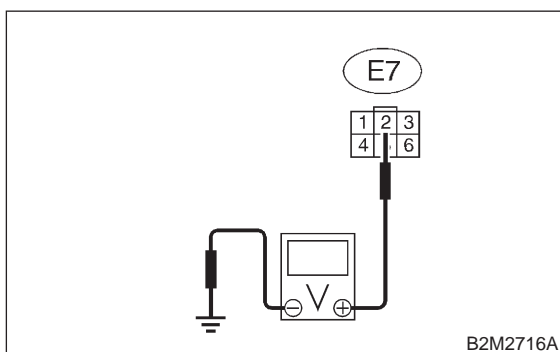

CHECK : *Is the voltage more than 10 V?*

YES : Go to step 11CR2.

NO : Repair harness and connector.

NOTE:

In this case, repair the following:

- Open circuit in harness between idle air control solenoid valve and main relay connector
- Poor contact in coupling connector (B22)

11CR2 : CHECK POWER SUPPLY TO IDLE AIR CONTROL SOLENOID VALVE.

Measure voltage between idle air control solenoid valve connector and engine ground.

Connector & terminal

(E7) No. 5 (+) — Engine ground (-):

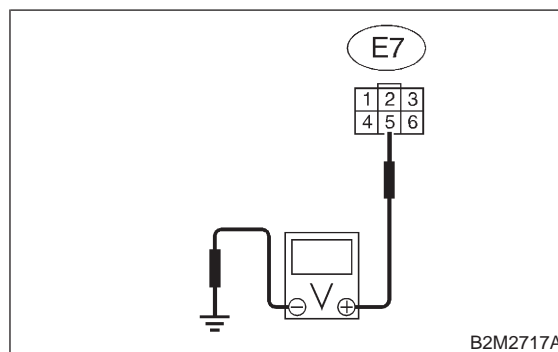

CHECK : *Is the voltage more than 10 V?*

YES : Go to step 11CR3.

NO : Repair harness and connector.

NOTE:

In this case, repair the following:

- Open circuit in harness between idle air control solenoid valve and main relay connector
- Poor contact in coupling connector (B22)

11CR3 : CHECK HARNESS BETWEEN ECM AND IDLE AIR CONTROL SOLENOID VALVE CONNECTOR.

- 1) Turn ignition switch to OFF.
- 2) Measure resistance between ECM and idle air control solenoid valve connector.

Connector & terminal

- #1; (B134) No. 5 — (E7) No. 4:
- #2; (B134) No. 6 — (E7) No. 1:
- #3; (B134) No. 19 — (E7) No. 6:
- #4; (B134) No. 20 — (E7) No. 3:

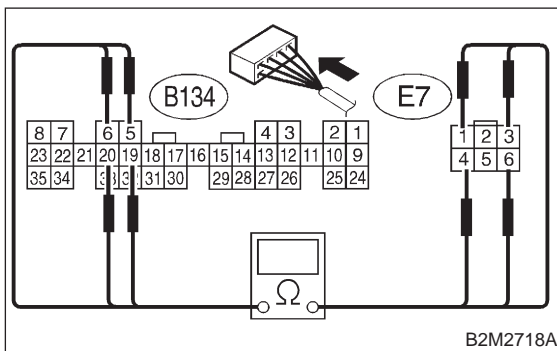

- CHECK** : Is the resistance less than 1 Ω?
- YES** : Go to step 11CR4.
- NO** : Repair harness and connector.

NOTE:

In this case, repair the following:

- Open circuit in harness between ECM and idle air control solenoid valve connector
- Poor contact in coupling connector (B21)

11CR4 : CHECK HARNESS BETWEEN ECM AND IDLE AIR CONTROL SOLENOID VALVE CONNECTOR.

- 1) Disconnect connector from ECM.
- 2) Measure resistance between ECM connector and chassis ground.

Connector & terminal

- #1; (B134) No. 5 — Chassis ground:
- #2; (B134) No. 6 — Chassis ground:
- #3; (B134) No. 19 — Chassis ground:
- #4; (B134) No. 20 — Chassis ground:

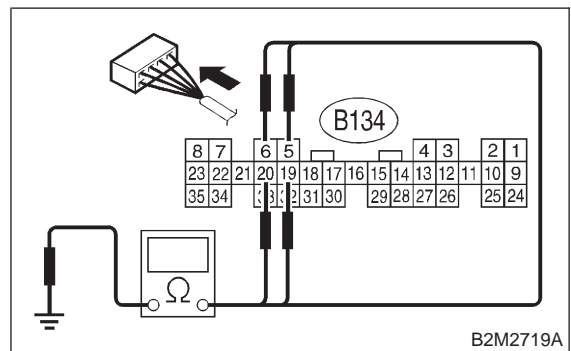

- CHECK** : Is the resistance less than 10 Ω?
- YES** : Repair ground short circuit in harness between ECM and idle air control solenoid valve connector.
- NO** : Go to step 11CR5.

11CR5 : CHECK POOR CONTACT.

Check poor contact in ECM connector and idle air control solenoid valve connector. <Ref. to FOREWORD [T3C1].>

CHECK : *Is there poor contact in ECM connector or idle air control solenoid valve connector?*

YES : Repair poor contact in ECM connector or idle air control solenoid valve connector.

NO : Replace idle air control solenoid valve. <Ref. to 2-7 [W12A0].>

MEMO:

CS: DTC P1517 — IDLE AIR CONTROL SOLENOID VALVE SIGNAL 4 CIRCUIT HIGH INPUT —

- **DTC DETECTING CONDITION:**
 - Immediately at fault recognition
- **TROUBLE SYMPTOM:**
 - Erroneous idling
 - Engine stalls.
 - Engine breathing

CAUTION:

After repair or replacement of faulty parts, conduct **CLEAR MEMORY MODE** <Ref. to 2-7 [T3D0].> and **INSPECTION MODE** <Ref. to 2-7 [T3E0].>

● **WIRING DIAGRAM:**

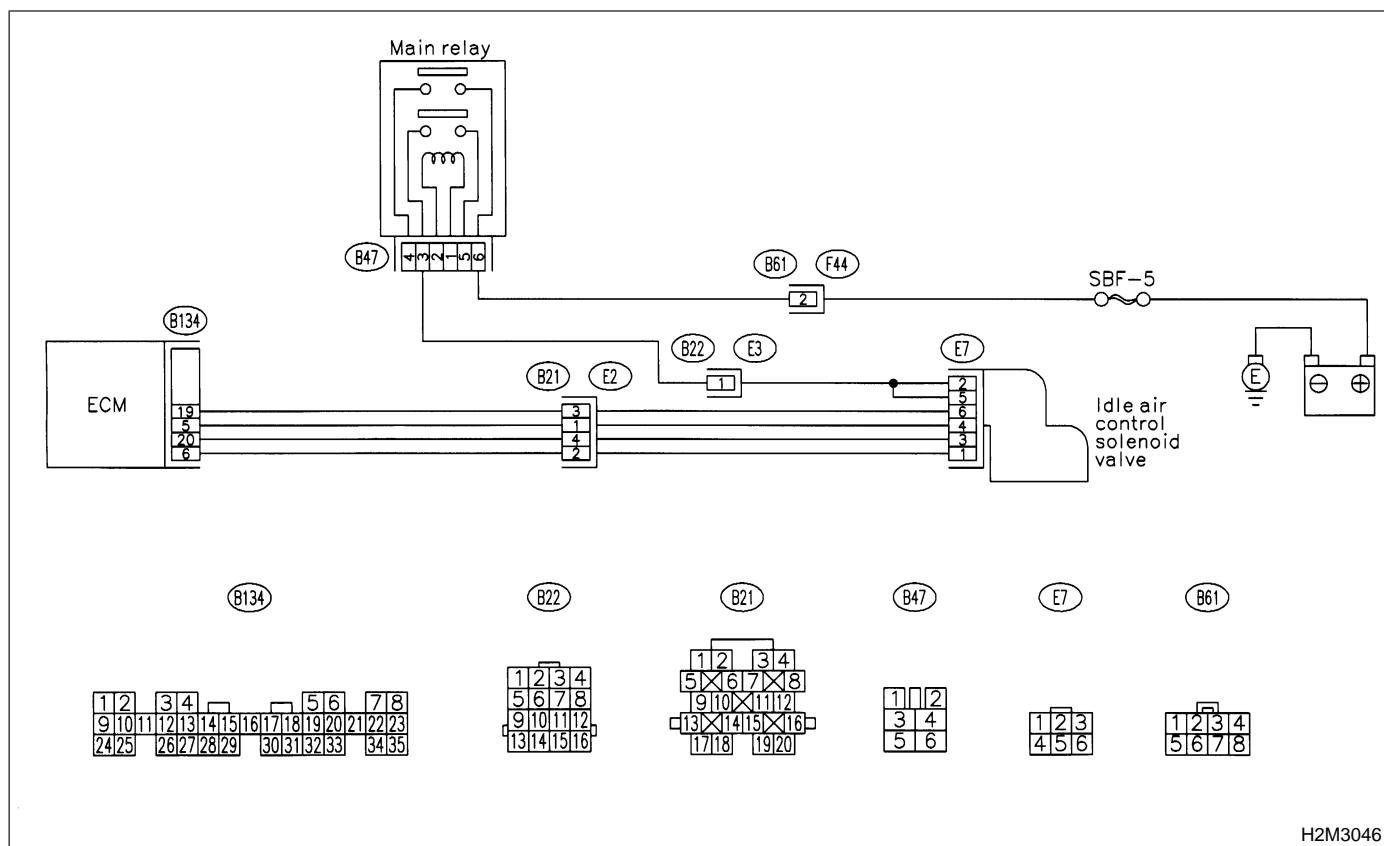

H2M3046

11CS1 : CHECK ANY OTHER DTC ON DISPLAY.

- CHECK** : Does the Subaru Select Monitor or OBD-II general scan tool indicate DTC P1511, P1513, P1515 and P1517 at same time?
- YES** : Go to step 11CS2.
- NO** : Go to step 11CS3.

11CS2 : CHECK GROUND CIRCUIT FOR ECM.

- 1) Turn ignition switch to OFF.
- 2) Measure resistance between ECM connector and chassis ground.

Connector & terminal
(B134) No. 7 — Chassis ground:

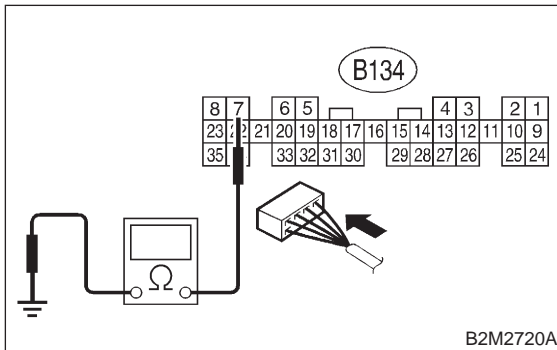

- CHECK** : Is the resistance less than 5 Ω?
YES : Go to step 11CS3.
NO : Repair harness and connector.

NOTE:

- In this case, repair the following:
- Open circuit in harness between ECM connector and engine ground terminal
 - Poor contact in ECM connector
 - Poor contact in coupling connector (B22)

11CS3 : CHECK HARNESS BETWEEN ECM AND IDLE AIR CONTROL SOLENOID VALVE CONNECTOR.

- 1) Turn ignition switch to OFF.
- 2) Disconnect connector from idle air control solenoid valve.
- 3) Turn ignition switch to ON.
- 4) Measure voltage between ECM connector and chassis ground.

Connector & terminal
#1; (B134) No. 5 (+) — Chassis ground (-):
#2; (B134) No. 6 (+) — Chassis ground (-):
#3; (B134) No. 19 (+) — Chassis ground (-):
#4; (B134) No. 20 (+) — Chassis ground (-):

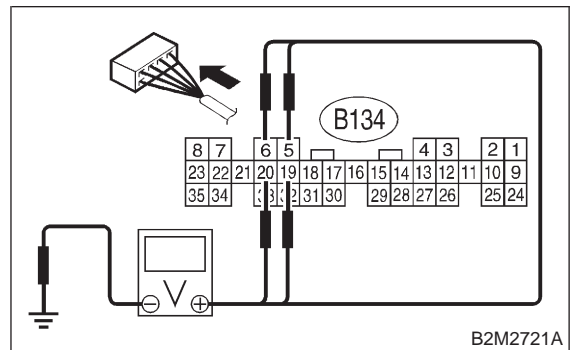

- CHECK** : Is the voltage more than 10 V?
YES : Repair battery short circuit in harness between ECM and idle air control solenoid valve connector. After repair, replace ECM. <Ref. to 2-7 [W15A0].>
NO : Replace ECM. <Ref. to 2-7 [W15A0].>

CT: DTC P1520 — COOLING FAN RELAY 1 CIRCUIT HIGH INPUT —

- **DTC DETECTING CONDITION:**
 - Two consecutive driving cycles with fault
- **TROUBLE SYMPTOM:**
 - Radiator fan does not operate properly.
 - Overheating

CAUTION:

After repair or replacement of faulty parts, conduct **CLEAR MEMORY MODE** <Ref. to 2-7 [T3D0].> and **INSPECTION MODE** <Ref. to 2-7 [T3E0].>

● **WIRING DIAGRAM:**

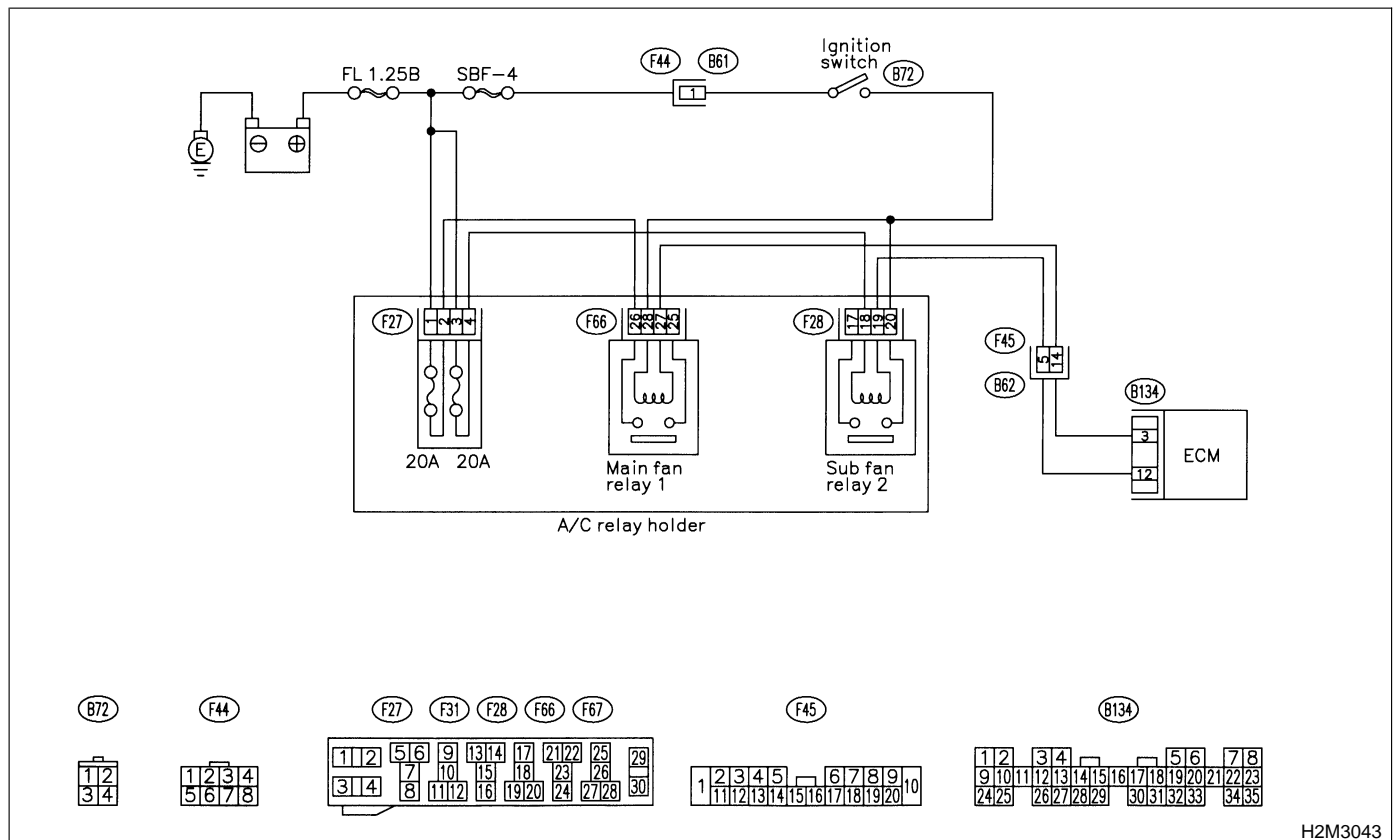

2-7 [T11CT1]

ON-BOARD DIAGNOSTICS II SYSTEM

11. Diagnostics Chart with Trouble Code for Except 2200 cc California Spec. Vehicles

11CT1 : CHECK OUTPUT SIGNAL FROM ECM.

- 1) Turn ignition switch to OFF.
- 2) Connect test mode connector at the lower portion of instrument panel (on the driver's side), to the side of the center console box.

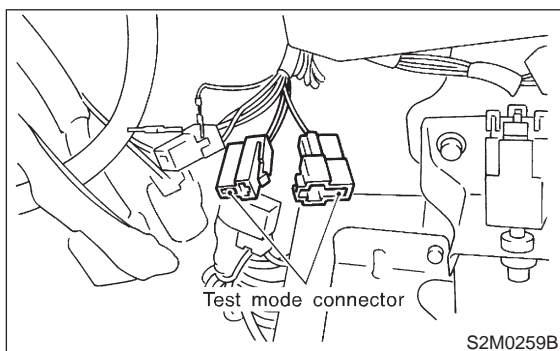

- 3) Turn ignition switch to ON.
- 4) Measure voltage between ECM and chassis ground.

NOTE:

Radiator fan relay operation check can be executed using Subaru Select Monitor. For procedure, refer to "COMPULSORY VALVE OPERATION CHECK MODE". <Ref. to 2-7 [T3F0].>

Connector & terminal

(B134) No. 3 (+) — Chassis ground (-):

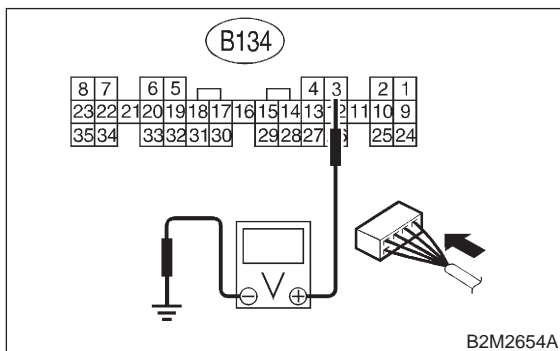

CHECK : Does voltage change between 0 and 10 volts?

YES : Even if MIL lights up, the circuit has returned to a normal condition at this time. In this case, repair poor contact in ECM connector.

NO : Go to step 11CT2.

11CT2 : CHECK SHORT CIRCUIT IN RADIATOR FAN RELAY 1 CONTROL CIRCUIT.

- 1) Turn ignition switch to OFF.
- 2) Remove main fan relay 1 and sub fan relay 1. (with A/C models)
Remove main fan relay. (without A/C models)
- 3) Disconnect test mode connector.
- 4) Turn ignition switch to ON.
- 5) Measure voltage between ECM and chassis ground.

Connector & terminal

(B134) No. 3 (+) — Chassis ground (-):

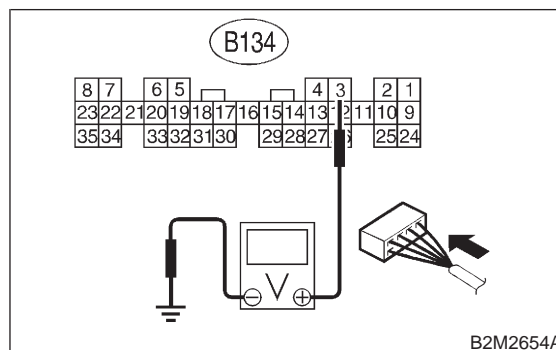

CHECK : Is the voltage more than 10 V?

YES : Repair battery short circuit in radiator fan relay 1 control circuit. After repair, replace ECM. <Ref. to 2-7 [W15A0].>

NO : Go to step 11CT3.

11CT3 : CHECK VEHICLE MODEL.

CHECK : Is the vehicle equipped with A/C?

YES : Go to step 11CT4.

NO : Go to step 11CT6.

11CT4 : CHECK MAIN FAN RELAY 1.

- 1) Turn ignition switch to OFF.
- 2) Remove main fan relay 1.
- 3) Measure resistance between main fan relay 1 terminals.

Terminal

No. 27 — No. 28:

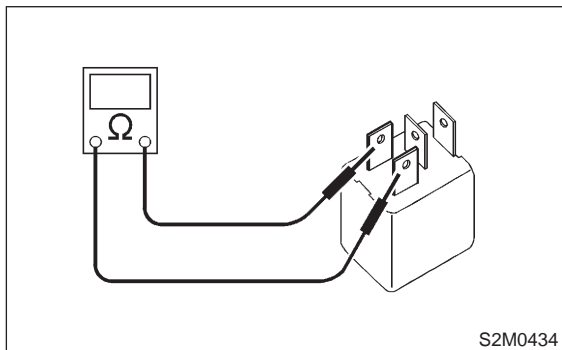

- CHECK** : *Is the resistance less than 1 Ω?*
- YES** : Replace main fan relay 1 and ECM <Ref. to 2-7 [W15A0].>
- NO** : Go to step 11CT5.

11CT5 : CHECK SUB FAN RELAY 1.

- 1) Remove sub fan relay 1.
- 2) Measure resistance between sub fan relay 1 terminals.

Terminal

No. 20 — No. 19

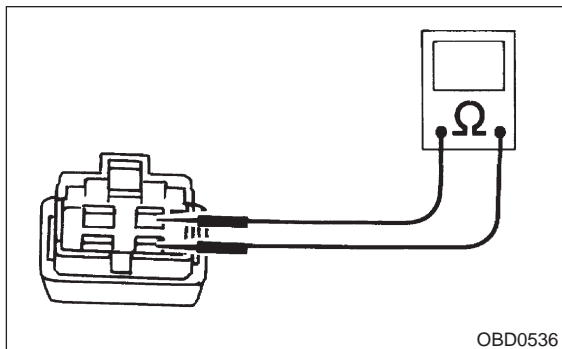

- CHECK** : *Is the resistance less than 1 Ω?*
- YES** : Replace sub fan relay 1 and ECM <Ref. to 2-7 [W15A0].>
- NO** : Go to step 11CT6.

11CT6 : CHECK POOR CONTACT.

Check poor contact in ECM connector. <Ref. to FOREWORD [T3C1].>

- CHECK** : *Is there poor contact in ECM connector?*
- YES** : Repair poor contact in ECM connector.
- NO** : Replace ECM. <Ref. to 2-7 [W15A0].>

2-7 [T11CT6]

ON-BOARD DIAGNOSTICS II SYSTEM

11. Diagnostics Chart with Trouble Code for Except 2200 cc California Spec. Vehicles

MEMO:

CU: DTC P1540 — VEHICLE SPEED SENSOR MALFUNCTION 2 —

- **DTC DETECTING CONDITION:**
 - Immediately at fault recognition

CAUTION:

After repair or replacement of faulty parts, conduct **CLEAR MEMORY MODE** <Ref. to 2-7 [T3D0].> and **INSPECTION MODE** <Ref. to 2-7 [T3E0].>

● **WIRING DIAGRAM:**

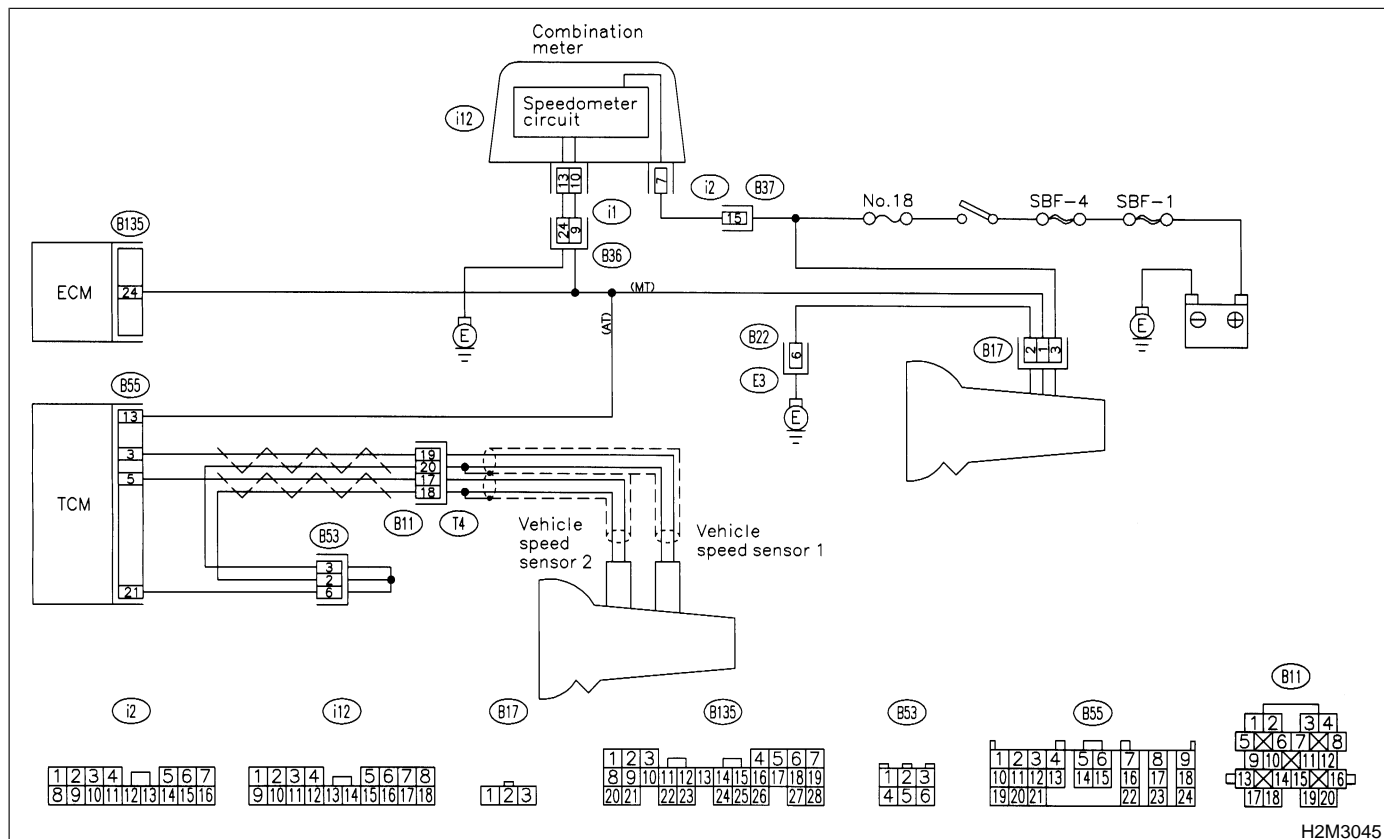

H2M3045

11CU1 : CHECK TRANSMISSION TYPE.

- CHECK** : *Is transmission type AT?*
- YES** : Go to step 11CU2.
- NO** : Go to step 11CU3.

11CU2 : CHECK DTC P0720 ON DISPLAY.

- CHECK** : *Does the Subaru Select Monitor or OBD-II general scan tool indicate DTC P0720?*
- YES** : Check vehicle speed sensor 2 signal circuit. <Ref. to 3-2 [T8G0].>
- NO** : Go to step 11CU3.

11CU3 : CHECK SPEEDOMETER OPERATION IN COMBINATION METER.

- CHECK** : *Does speedometer operate normally?*
- YES** : Go to step 11CU4.
- NO** : Check speedometer and vehicle speed sensor. <Ref. to 6-2 [K2A4].>

2-7 [T11CU4]

ON-BOARD DIAGNOSTICS II SYSTEM

11. Diagnostics Chart with Trouble Code for Except 2200 cc California Spec. Vehicles

11CU4 : CHECK HARNESS BETWEEN ECM AND COMBINATION METER CONNECTOR.

- 1) Turn ignition switch to OFF.
- 2) Disconnect connector from TCM.
- 3) Turn ignition switch to ON.
- 4) Measure voltage between ECM and chassis ground.

Connector & terminal

(B135) No. 24 (+) — Chassis ground (-):

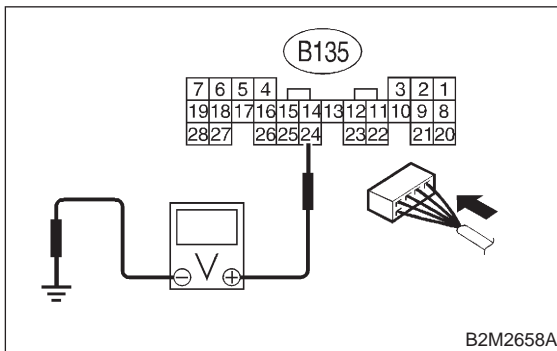

- CHECK** : Is the voltage more than 2 V?
YES : Repair harness and connector.

NOTE:

In this case, repair the following:

- Open circuit in harness between ECM and combination meter connector
- Poor contact in ECM connector
- Poor contact in combination meter connector

- NO** : Go to step 11CU5.

11CU5 : CHECK HARNESS BETWEEN ECM AND COMBINATION METER CONNECTOR.

- 1) Turn ignition switch to OFF.
- 2) Disconnect connector from ECM.
- 3) Measure resistance of harness between ECM connector and chassis ground.

Connector & terminal

(B135) No. 24 — Chassis ground:

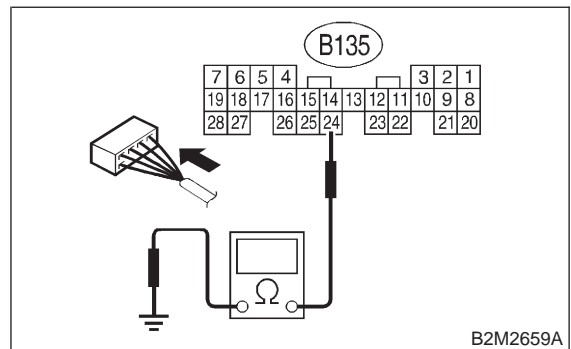

- CHECK** : Is the resistance less than 10 Ω?
YES : Repair ground short circuit in harness between ECM and combination meter connector.
NO : Repair poor contact in ECM connector.

CV: DTC P1560 — BACK-UP VOLTAGE CIRCUIT MALFUNCTION —

- DTC DETECTING CONDITION:
 - Two consecutive driving cycles with fault

CAUTION:

After repair or replacement of faulty parts, conduct CLEAR MEMORY MODE <Ref. to 2-7 [T3D0].> and INSPECTION MODE <Ref. to 2-7 [T3E0].>

● WIRING DIAGRAM:

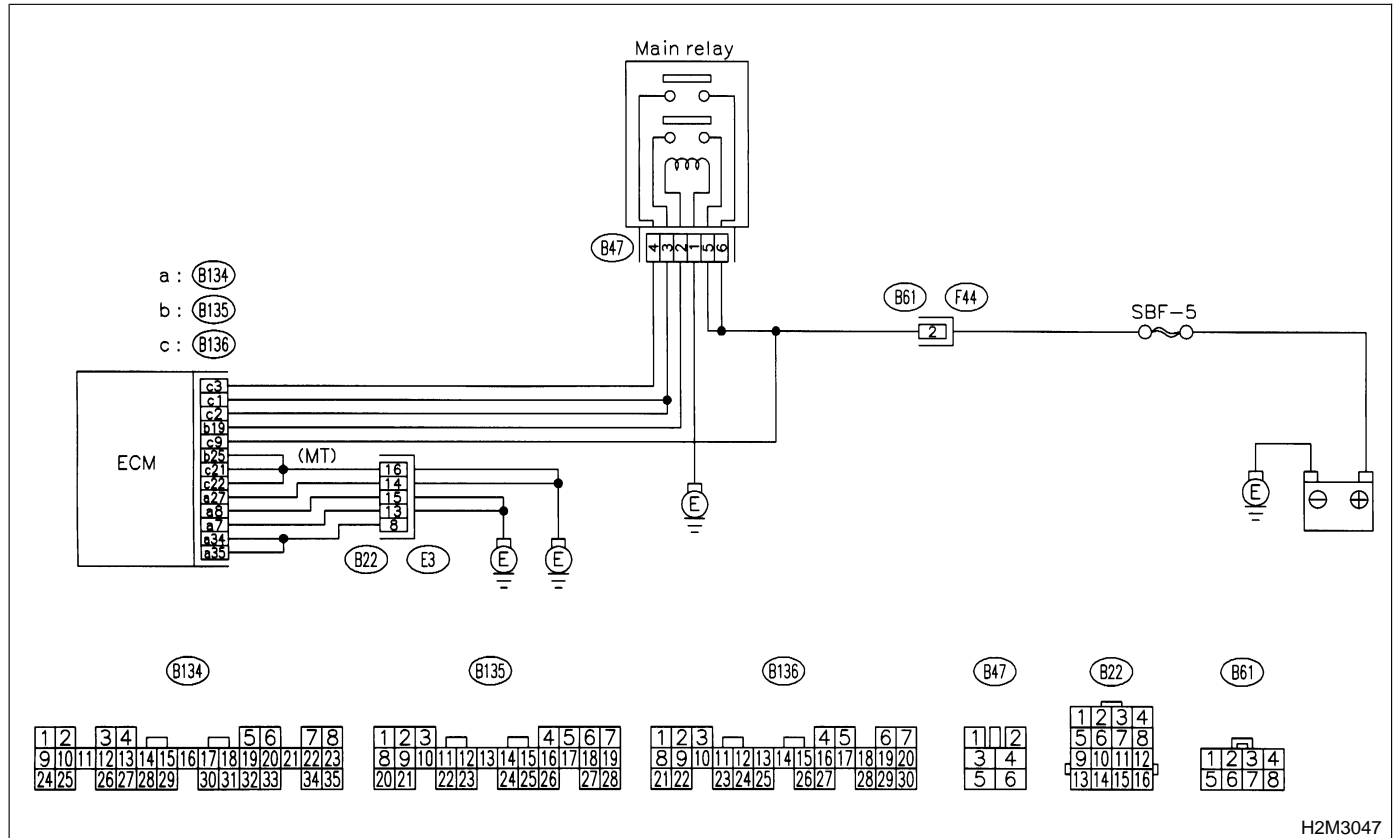

H2M3047

2-7 [T11CV1]

ON-BOARD DIAGNOSTICS II SYSTEM

11. Diagnostics Chart with Trouble Code for Except 2200 cc California Spec. Vehicles

11CV1 : CHECK INPUT SIGNAL FOR ECM.

- 1) Turn ignition switch to OFF.
- 2) Measure voltage between ECM and chassis ground.

Connector & terminal

(B136) No. 9 (+) — Chassis ground (-):

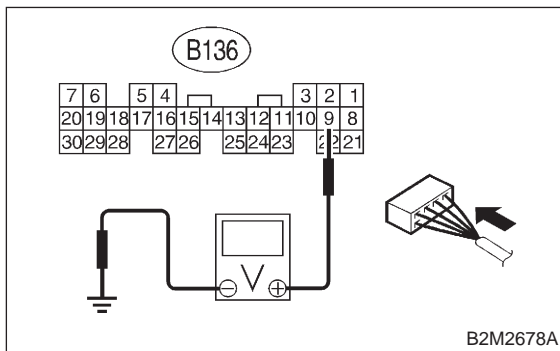

- CHECK** : *Is the voltage more than 10 V?*
- YES** : Repair poor contact in ECM connector.
- NO** : Go to step 11CV2.

11CV2 : CHECK HARNESS BETWEEN ECM AND MAIN FUSE BOX CONNECTOR.

- 1) Disconnect connector from ECM.
- 2) Measure resistance of harness between ECM and chassis ground.

Connector & terminal

(B136) No. 9 — Chassis ground:

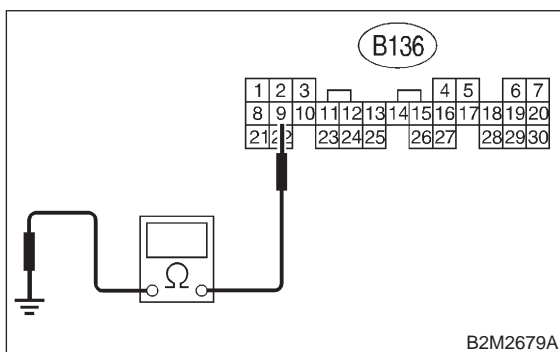

- CHECK** : *Is the resistance less than 10 Ω?*
- YES** : Repair ground short circuit in harness between ECM connector and battery terminal.
- NO** : Go to step 11CV3.

11CV3 : CHECK FUSE SBF-2.

- CHECK** : *Is fuse blown?*
- YES** : Replace fuse. <Ref. to 6-3 [D6B1].>
- NO** : Go to step 11CV4.

11CV4 : CHECK HARNESS BETWEEN ECM AND MAIN FUSE BOX CONNECTOR.

- 1) Disconnect connector from main fuse box.
- 2) Measure resistance of harness between ECM and main fuse box connector.

Connector & terminal

(B136) No. 9 — (F37) No. 1:

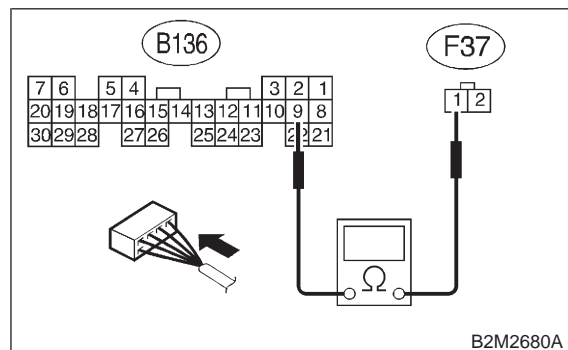

- CHECK** : *Is the resistance less than 1 Ω?*
- YES** : Repair poor contact in ECM and main fuse box connector.
- NO** : Repair harness and connector.

NOTE:

In this case, repair the following:

- Open circuit in harness between ECM and main fuse box connector
- Poor contact in coupling connector (F44)
- Poor contact in ECM connector
- Poor contact in main fuse box connector

CW: DTC P1700 — THROTTLE POSITION SENSOR CIRCUIT MALFUNCTION FOR AUTOMATIC TRANSMISSION —

● **DTC DETECTING CONDITION:**

- Two consecutive driving cycles with fault

● **TROUBLE SYMPTOM:**

- Shift point too high or too low; engine brake not effected in “3” range; excessive shift shock; excessive tight corner “braking”

CAUTION:

After repair or replacement of faulty parts, conduct **CLEAR MEMORY MODE** <Ref. to 2-7 [T3D0].> and **INSPECTION MODE** <Ref. to 2-7 [T3E0].>

● **WIRING DIAGRAM:**

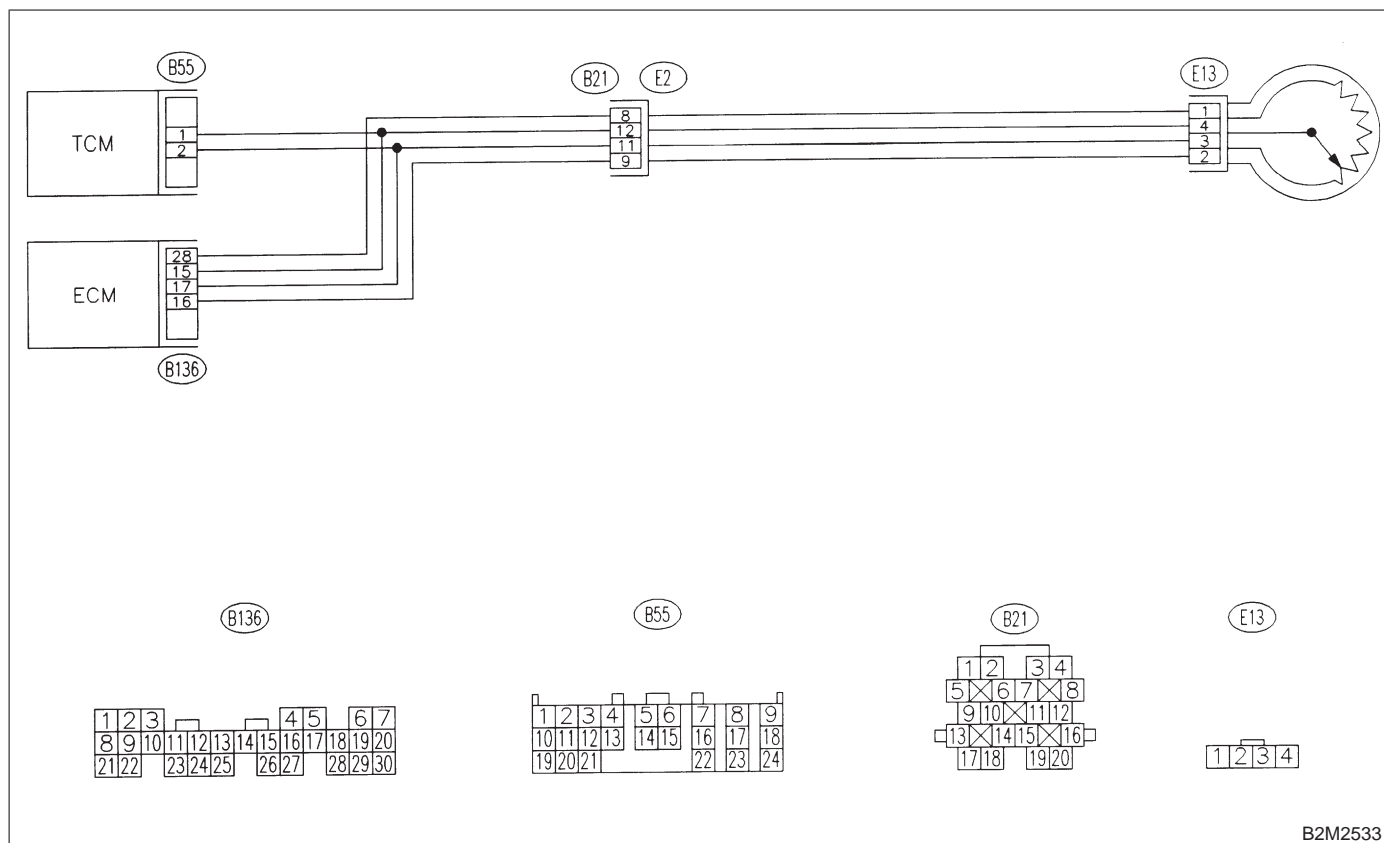

B2M2533

11CW1 : CHECK DTC P1700 ON DISPLAY.

- CHECK** : Does the Subaru Select Monitor or OBD-II general scan tool indicate DTC P1700?
- YES** : Check throttle position sensor circuit. <Ref. to 3-2 [T8F0].>
- NO** : It is not necessary to inspect DTC P1700.

MEMO:

CX: DTC P1701 — CRUISE CONTROL SET SIGNAL CIRCUIT MALFUNCTION FOR AUTOMATIC TRANSMISSION —

● DTC DETECTING CONDITION:

- Two consecutive driving cycles with fault

CAUTION:

After repair or replacement of faulty parts, conduct CLEAR MEMORY MODE <Ref. to 2-7 [T3D0].> and INSPECTION MODE <Ref. to 2-7 [T3E0].>

● WIRING DIAGRAM:

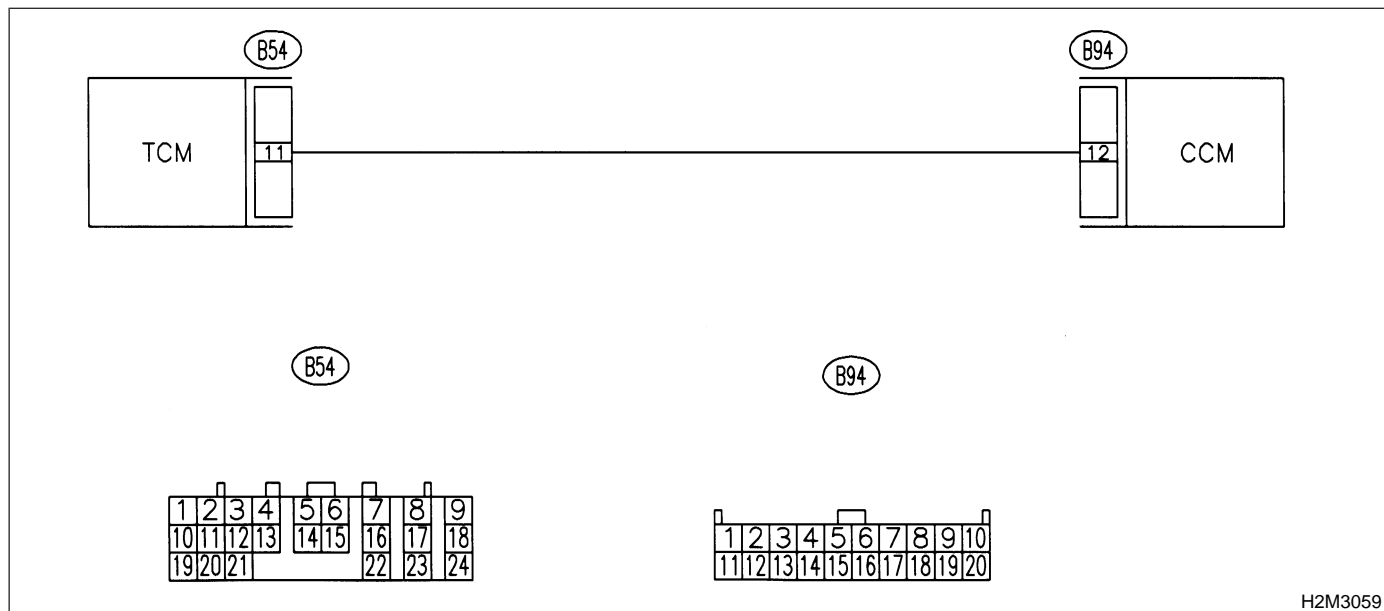

11CX1 : CHECK HARNESS BETWEEN TCM AND CCM CONNECTOR.

11CX2 : CHECK HARNESS BETWEEN TCM AND CCM CONNECTOR.

- 1) Turn ignition switch to OFF.
- 2) Disconnect connectors from TCM and CCM.
- 3) Measure resistance of harness between TCM and CCM connector.

Measure resistance of harness between TCM and chassis ground.

Connector & terminal
(B54) No. 11 — Chassis ground:

Connector & terminal

(B54) No. 11 — (B94) No. 12:

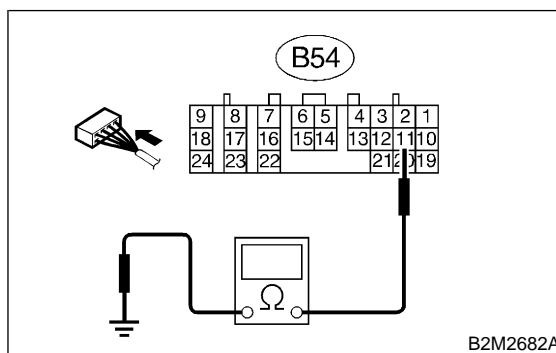
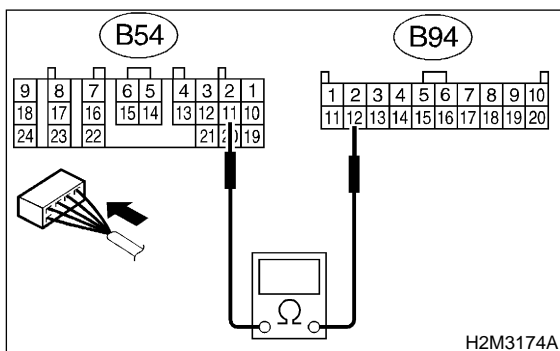

- (CHECK)** : **Is the resistance less than 1 Ω?**
- (YES)** : Go to step 11CX2.
- (NO)** : Repair open circuit in harness between TCM and CCM connector.

- (CHECK)** : **Is the resistance less than 10 Ω?**
- (YES)** : Repair short circuit in harness between TCM and CCM connector.
- (NO)** : Go to step 11CX3.

2-7 [T11CX3]

ON-BOARD DIAGNOSTICS II SYSTEM

11. Diagnostics Chart with Trouble Code for Except 2200 cc California Spec. Vehicles

11CX3 : CHECK INPUT SIGNAL FOR TCM.

- 1) Connect connector to TCM and CCM.
- 2) Lift-up the vehicle or set the vehicle on free rollers.

CAUTION:

On AWD models, raise all wheels off ground.

- 3) Start the engine.
- 4) Cruise control main switch to ON.
- 5) TCS OFF switch to ON. (with TCS models only)
- 6) Move selector lever to "D" and slowly increase vehicle speed to 50 km/h (31 MPH).
- 7) Cruise control set switch to ON.
- 8) Measure voltage between TCM and chassis ground.

Connector & terminal

(B54) No. 11 (+) — Chassis ground (-):

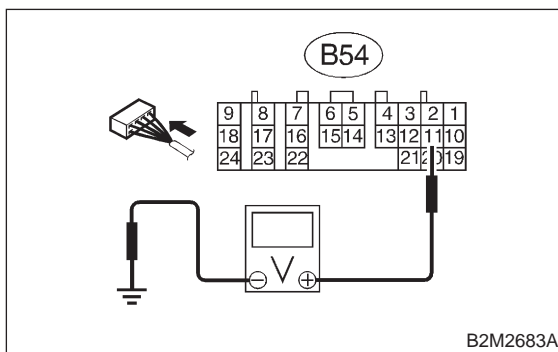

- CHECK** : *Is the voltage less than 1 V?*
- YES** : Go to step **11CX4**.
- NO** : Check cruise control set circuit.

11CX4 : CHECK POOR CONTACT.

Check poor contact in TCM connector. <Ref. to FOREWORD [T3C1].>

- CHECK** : *Is there poor contact in TCM connector?*
- YES** : Repair poor contact in TCM connector.
- NO** : Replace TCM. <Ref. to 3-2 [W22A0].>

CY: DTC P1702 — AUTOMATIC TRANSMISSION DIAGNOSIS INPUT SIGNAL CIRCUIT LOW INPUT —

- **DTC DETECTING CONDITION:**
 - Two consecutive driving cycles with fault

CAUTION:

After repair or replacement of faulty parts, conduct **CLEAR MEMORY MODE** <Ref. to 2-7 [T3D0].> and **INSPECTION MODE** <Ref. to 2-7 [T3E0].>

- **WIRING DIAGRAM:**

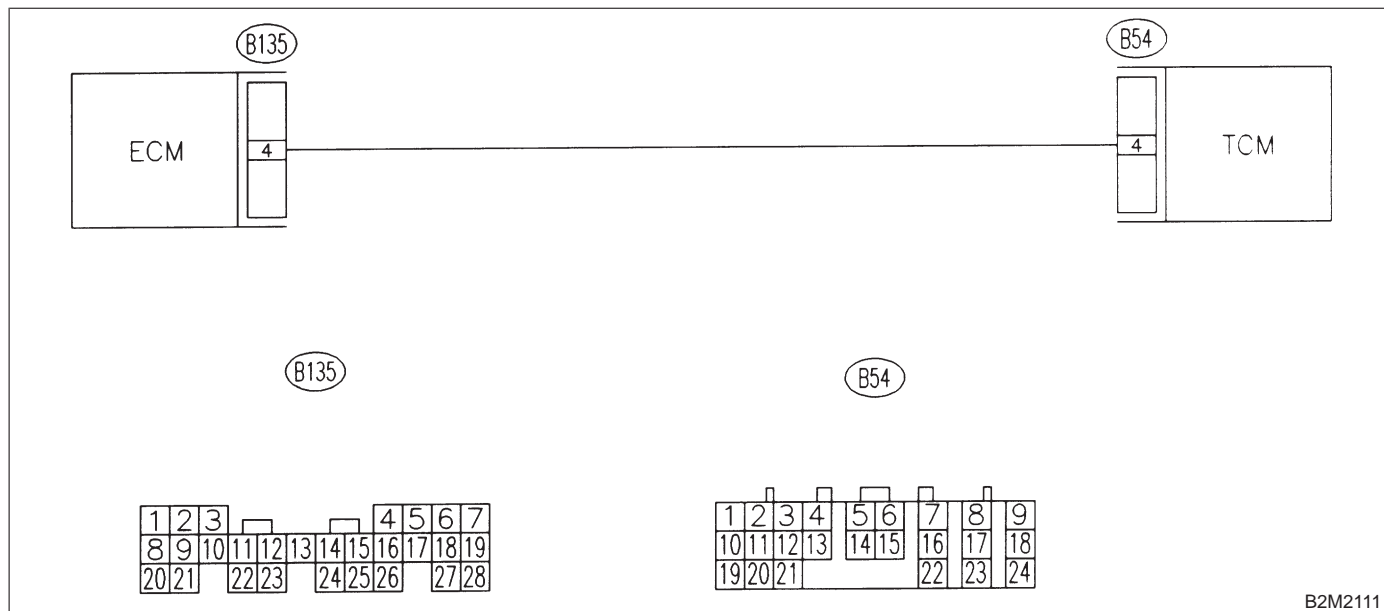

B2M2111

11CY1 : CHECK TRANSMISSION TYPE.

- CHECK** : *Is transmission type AT?*
- YES** : Go to step 11CY2.
- NO** : Check AT/MT identification circuit. <Ref. to 2-7 [T11DE0].>

2-7 [T11CY2]

ON-BOARD DIAGNOSTICS II SYSTEM

11. Diagnostics Chart with Trouble Code for Except 2200 cc California Spec. Vehicles

11CY2 : CHECK HARNESS BETWEEN ECM AND TCM CONNECTOR.

- 1) Turn ignition switch to ON.
- 2) Measure voltage between ECM and chassis ground.

Connector & terminal

(B135) No. 4 (+) — Chassis ground (-):

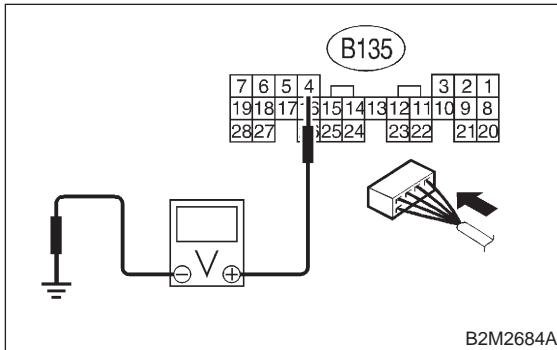

CHECK : Is the voltage less than 1 V?

YES : Go to step 11CY3.

NO : Even if MIL lights up, the circuit has returned to a normal condition at this time.

NOTE:

In this case, repair the following:

- Poor contact in ECM connector
- Poor contact in TCM connector

11CY3 : CHECK HARNESS BETWEEN ECM AND TCM CONNECTOR.

- 1) Turn ignition switch to OFF.
- 2) Disconnect connector from ECM and TCM.
- 3) Measure resistance of harness between ECM and chassis ground.

Connector & terminal

(B135) No. 4 — Chassis ground:

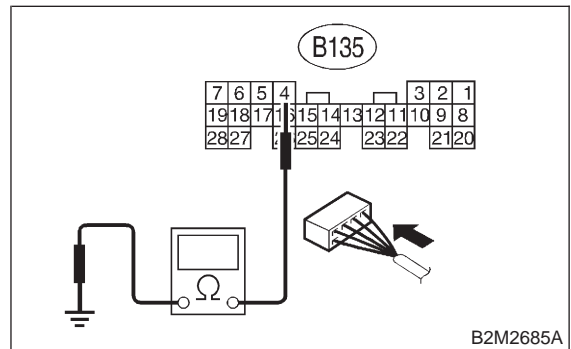

CHECK : Is the resistance less than 10 Ω?

YES : Repair ground short circuit in harness between ECM and TCM connector.

NO : Go to step 11CY4.

11CY4 : CHECK OUTPUT SIGNAL FOR ECM.

- 1) Connect connector to ECM.
- 2) Turn ignition switch to ON.
- 3) Measure voltage between ECM and chassis ground.

Connector & terminal

(B135) No. 4 (+) — Chassis ground (-):

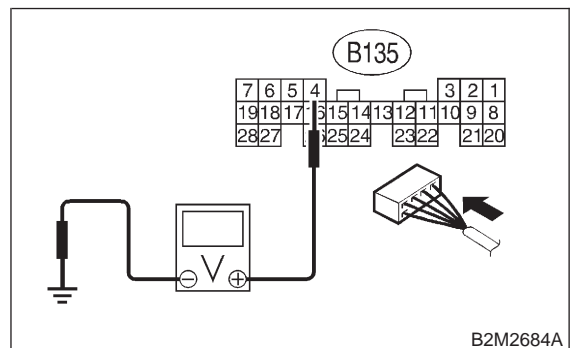

CHECK : Is the voltage more than 5 V?

YES : Replace TCM. <Ref. to 3-2 [W22A0].>

NO : Repair poor contact in ECM connector.

CZ: DTC P1703 — LOW CLUTCH TIMING CONTROL SOLENOID VALVE CIRCUIT MALFUNCTION —

● **DTC DETECTING CONDITION:**

- Two consecutive driving cycles with fault

CAUTION:

After repair or replacement of faulty parts, conduct CLEAR MEMORY MODE <Ref. to 2-7 [T3D0].> and INSPECTION MODE <Ref. to 2-7 [T3E0].>

● **WIRING DIAGRAM:**

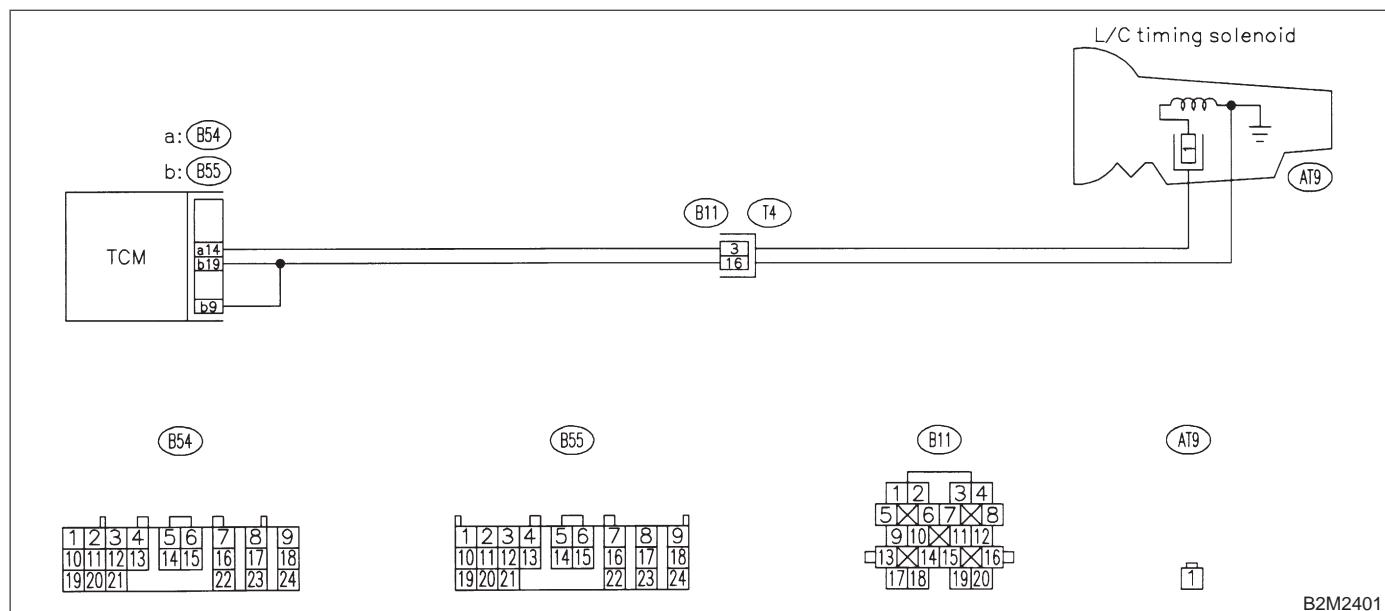

B2M2401

11CZ1 : CHECK DTC P1703 ON DISPLAY.

CHECK : Does the Subaru Select Monitor or OBD-II general scan tool indicate DTC P1703?

YES : Check low clutch timing control solenoid valve circuit. <Ref. to 3-2 [T8M0].>

NO : It is not necessary to inspect DTC P1703.

DA: DTC P1704 — 2-4 BRAKE TIMING CONTROL SOLENOID VALVE CIRCUIT MALFUNCTION —

- **DTC DETECTING CONDITION:**
 - Two consecutive driving cycles with fault

CAUTION:

After repair or replacement of faulty parts, conduct **CLEAR MEMORY MODE** <Ref. to 2-7 [T3D0].> and **INSPECTION MODE** <Ref. to 2-7 [T3E0].>

● **WIRING DIAGRAM:**

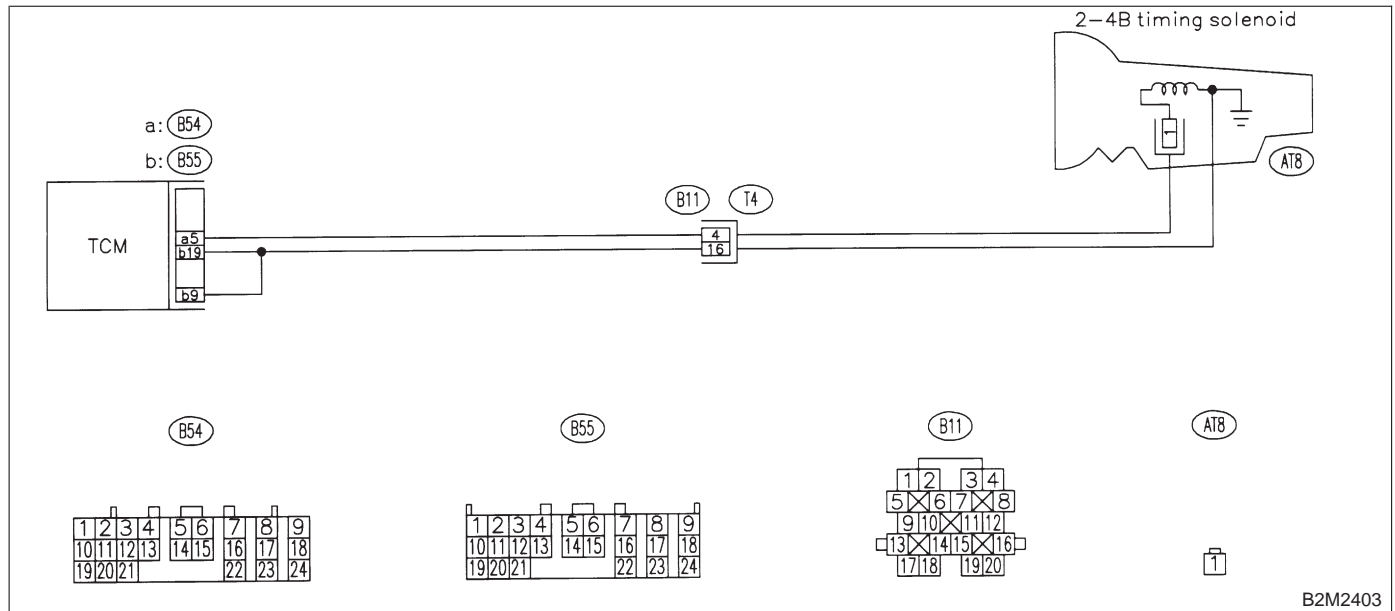

B2M2403

11DA1 : CHECK DTC P1704 ON DISPLAY.

- CHECK** : Does the Subaru Select Monitor or OBD-II general scan tool indicate DTC P1704?
- YES** : Check 2-4 brake timing control solenoid valve circuit. <Ref. to 3-2 [T8N0].>
- NO** : It is not necessary to inspect DTC P1704.

DB: DTC P1705 — 2-4 BRAKE PRESSURE CONTROL SOLENOID VALVE (DUTY SOLENOID D) CIRCUIT MALFUNCTION —

- **DTC DETECTING CONDITION:**
 - Two consecutive driving cycles with fault

CAUTION:

After repair or replacement of faulty parts, conduct CLEAR MEMORY MODE <Ref. to 2-7 [T3D0].> and INSPECTION MODE <Ref. to 2-7 [T3E0].>

● **WIRING DIAGRAM:**

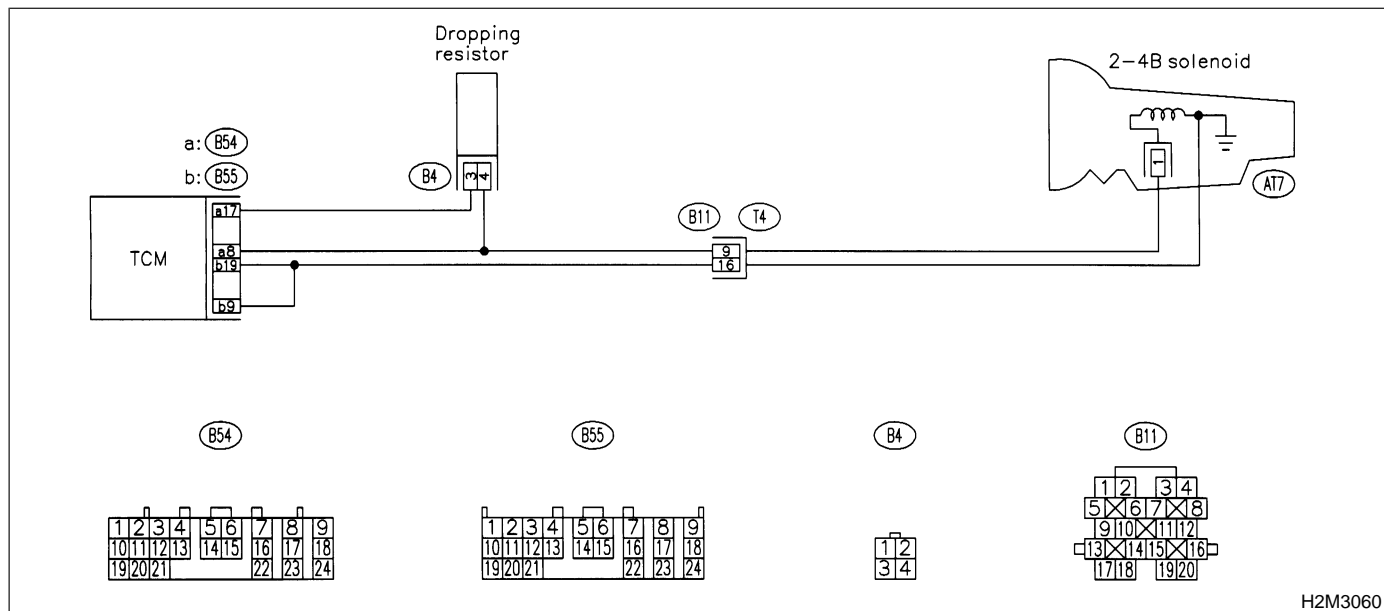

H2M3060

11DB1 : CHECK DTC P1705 ON DISPLAY.

- CHECK** : Does the Subaru Select Monitor or OBD-II general scan tool indicate DTC P1705?
- YES** : Check 2-4 brake pressure control solenoid valve circuit. <Ref. to 3-2 [T8P0].>
- NO** : It is not necessary to inspect DTC P1705.

2-7 [T11DB1]

ON-BOARD DIAGNOSTICS II SYSTEM

11. Diagnostics Chart with Trouble Code for Except 2200 cc California Spec. Vehicles

MEMO:

DC: DTC P1722 — AUTOMATIC TRANSMISSION DIAGNOSIS INPUT SIGNAL CIRCUIT HIGH INPUT —

● **DTC DETECTING CONDITION:**

- Two consecutive driving cycles with fault

CAUTION:

After repair or replacement of faulty parts, conduct CLEAR MEMORY MODE <Ref. to 2-7 [T3D0].> and INSPECTION MODE <Ref. to 2-7 [T3E0].>

● **WIRING DIAGRAM:**

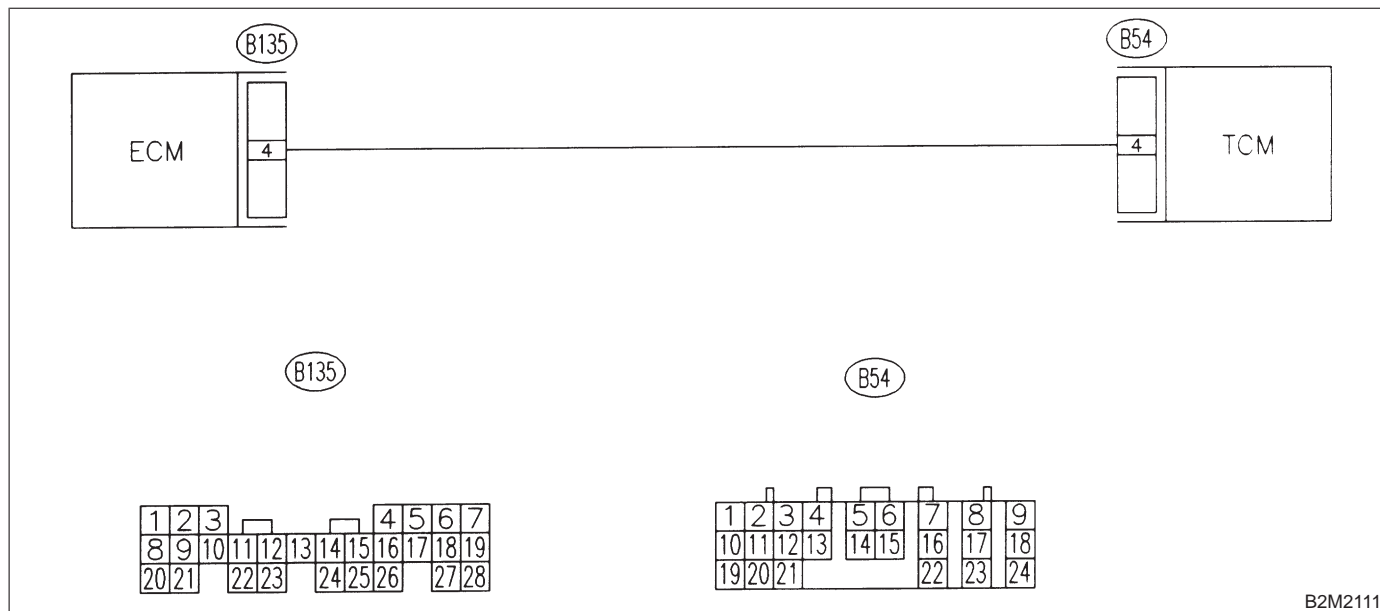

11DC1 : CHECK TRANSMISSION TYPE.

- CHECK** : *Is transmission type AT?*
- YES** : Go to step 11DC2.
- NO** : Check AT/MT identification circuit. <Ref. to 2-7 [T11DE0].>

2-7 [T11DC2]

ON-BOARD DIAGNOSTICS II SYSTEM

11. Diagnostics Chart with Trouble Code for Except 2200 cc California Spec. Vehicles

11DC2 : CHECK HARNESS BETWEEN ECM AND TCM CONNECTOR.

- 1) Turn ignition switch to ON.
- 2) Measure voltage between ECM and chassis ground.

Connector & terminal

(B135) No. 4 (+) — Chassis ground (-):

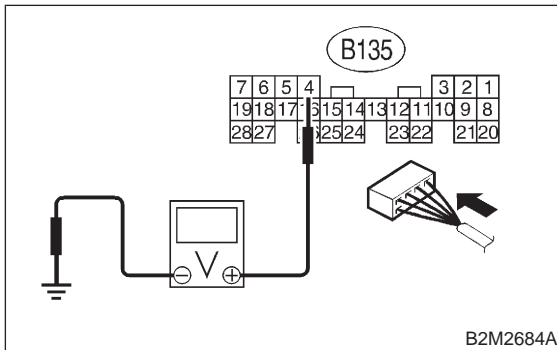

- CHECK** : **Is the voltage more than 10 V?**
- YES** : Repair battery short circuit in harness between ECM and TCM connector. After repair, replace ECM. <Ref. to 2-7 [W15A0].>
- NO** : Go to step 11DC3.

11DC3 : CHECK HARNESS BETWEEN ECM AND TCM CONNECTOR.

Measure voltage between ECM connector and chassis ground.

Connector & terminal

(B135) No. 4 (+) — Chassis ground (-):

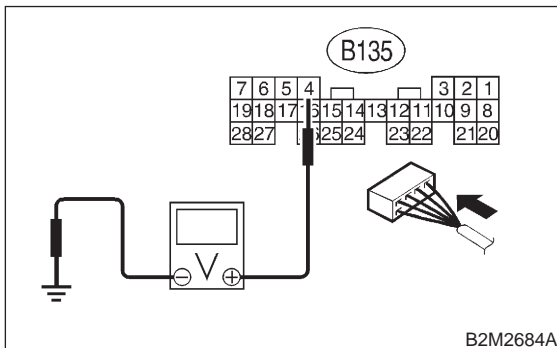

- CHECK** : **Is the voltage more than 4 V?**
- YES** : Go to step 11DC6.
- NO** : Go to step 11DC4.

11DC4 : CHECK HARNESS BETWEEN ECM AND TCM CONNECTOR.

Measure voltage between ECM connector and chassis ground.

Connector & terminal

(B135) No. 4 (+) — Chassis ground (-):

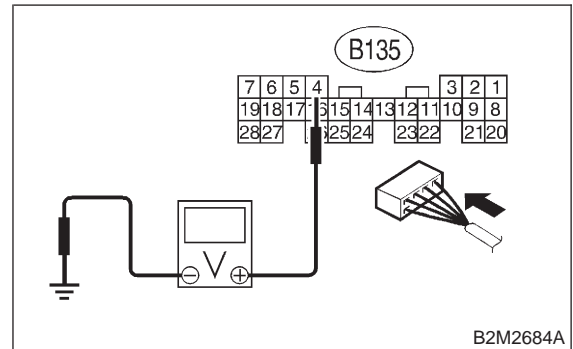

- CHECK** : **Is the voltage less than 1 V?**
- YES** : Repair poor contact in ECM connector.
- NO** : Go to step 11DC5.

11DC5 : CHECK OUTPUT SIGNAL FROM ECM.

Measure voltage between ECM and chassis ground.

Connector & terminal
(B135) No. 4 (+) — Chassis ground (-):

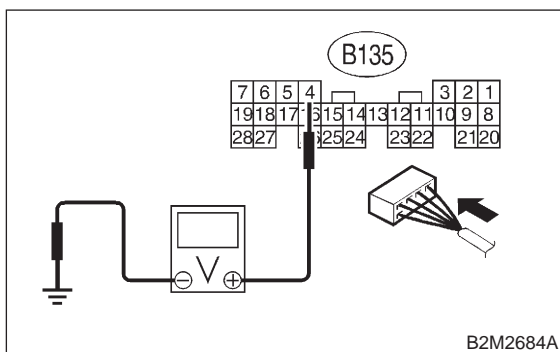

CHECK : Does the voltage change from 1 V to 4 V while monitoring the value with voltage meter?

YES : Even if MIL lights up, the circuit has returned to a normal condition at this time.

NOTE:

In this case, repair the following:

- Poor contact in ECM connector
- Poor contact in TCM connector

NO : Contact with SOA service.

NOTE:

Inspection by DTM is required, because probable cause is deterioration of multiple parts.

11DC6 : CHECK HARNESS BETWEEN ECM AND TCM CONNECTOR.

Measure voltage between TCM and chassis ground.

Connector & terminal
(B54) No. 4 (+) — Chassis ground (-):

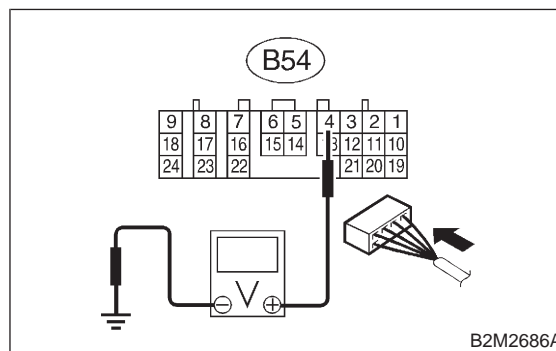

CHECK : Is the voltage more than 4 V?

YES : Go to step 11DC7.

NO : Repair open circuit in harness between ECM and TCM connector.

11DC7 : CHECK POOR CONTACT.

Check poor contact in TCM connector. <Ref. to FOREWORD [T3C1].>

CHECK : Is there poor contact in TCM connector?

YES : Repair poor contact in TCM connector.

NO : Check TCM power supply line and grounding line.

DD: DTC P1742 — AUTOMATIC TRANSMISSION DIAGNOSIS INPUT SIGNAL CIRCUIT MALFUNCTION —

● **DTC DETECTING CONDITION:**

- Two consecutive driving cycles with fault

CAUTION:

After repair or replacement of faulty parts, conduct CLEAR MEMORY MODE <Ref. to 2-7 [T3D0].> and INSPECTION MODE <Ref. to 2-7 [T3E0].>

● **WIRING DIAGRAM:**

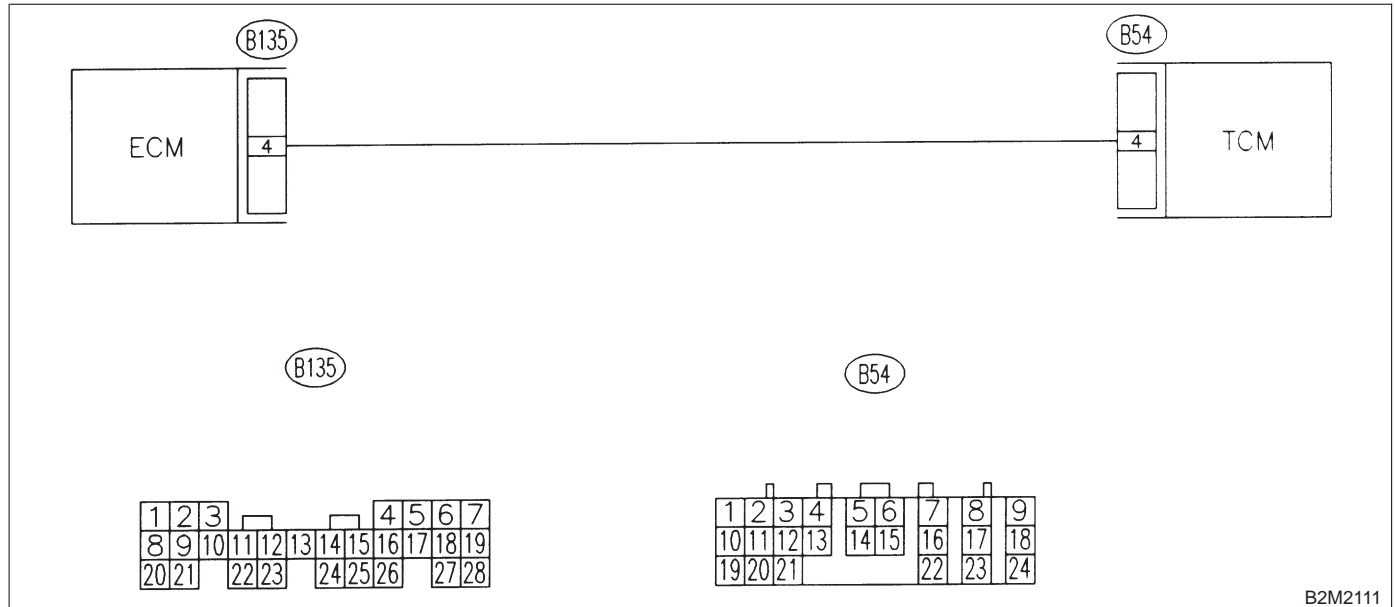

11DD1 : CHECK TRANSMISSION TYPE.

- CHECK** : *Is transmission type AT?*
- YES** : Go to step 11DD2.
- NO** : Check AT/MT identification circuit. <Ref. to 2-7 [T11DE0].>

11DD2 : CHECK DRIVING CONDITION.

- 1) Start and warm-up the engine until the radiator fan makes one complete rotation.
- 2) Drive the vehicle.

- CHECK** : *Is AT shift control functioning properly?*
- YES** : Go to step 11DD3.
- NO** : Replace TCM. <Ref. to 3-2 [W22A0].>

11DD3 : CHECK ACCESSORY.

- CHECK** : *Are car phone and/or CB installed on vehicle?*
- YES** : Repair grounding line of car phone or CB system.
- NO** : Replace TCM. <Ref. to 3-2 [W22A0].>

DE: — AT/MT IDENTIFICATION CIRCUIT MALFUNCTION [MT VEHICLES] —

CAUTION:

After repair or replacement of faulty parts, conduct CLEAR MEMORY MODE <Ref. to 2-7 [T3D0].> and INSPECTION MODE <Ref. to 2-7 [T3E0].>

● **WIRING DIAGRAM:**

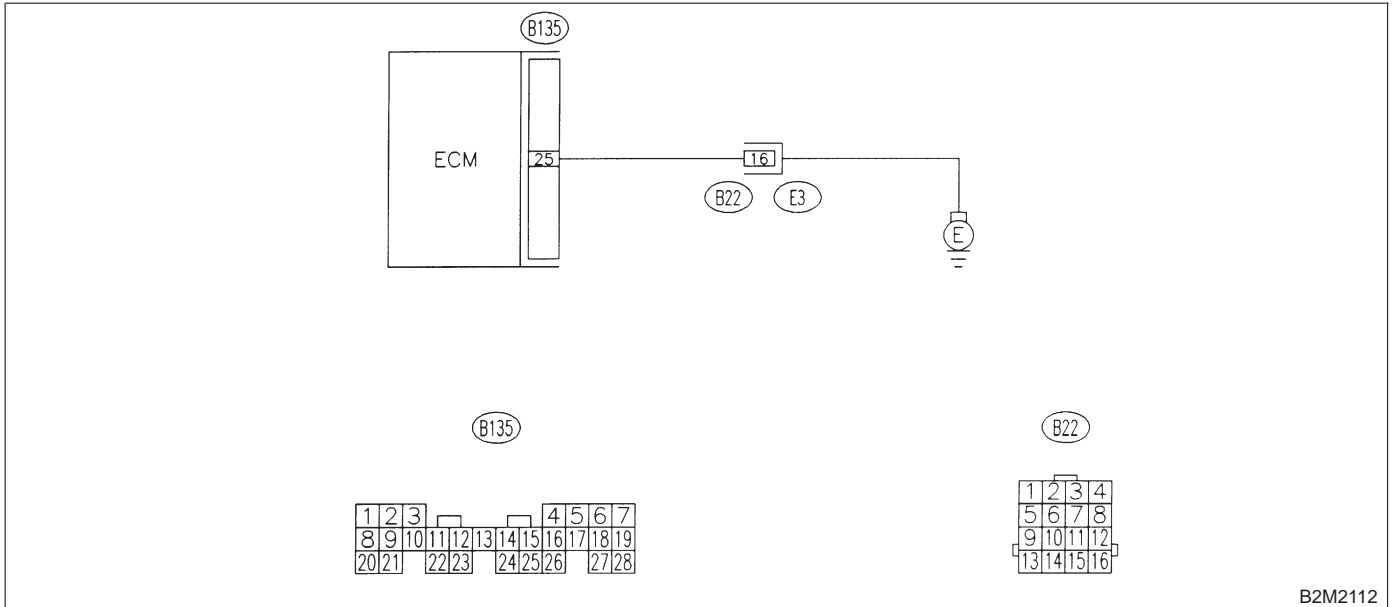

2-7 [T11DE1]

ON-BOARD DIAGNOSTICS II SYSTEM

11. Diagnostics Chart with Trouble Code for Except 2200 cc California Spec. Vehicles

11DE1 : CHECK HARNESS BETWEEN ECM CONNECTOR AND ENGINE GROUNDING TERMINAL.

- 1) Turn ignition switch to ON.
- 2) Measure voltage between ECM and chassis ground.

Connector & terminal

(B135) No. 25 (+) — Chassis ground (-):

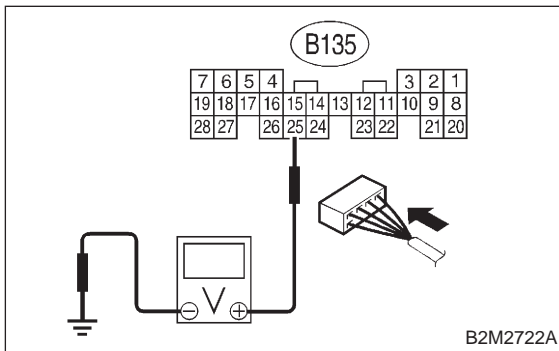

CHECK : *Is the voltage more than 2 V?*

YES : Repair harness and connector.

NOTE:

In this case, repair the following:

- Open circuit in harness between ECM connector and engine grounding terminal
- Poor contact in engine grounding terminal
- Poor contact in coupling connector (B22)

NO : Go to step **11DE2**.

11DE2 : CHECK POOR CONTACT.

Check poor contact in ECM connector. <Ref. to FOREWORD [T3C1].>

CHECK : *Is there poor contact in ECM connector?*

YES : Repair poor contact in ECM connector.

NO : Contact with SOA service.

NOTE:

Inspection by DTM is required, because probable cause is deterioration of multiple parts.