

5. Diagnostics Chart with Trouble Code

A: TROUBLE CODES

1. LIST OF TROUBLE CODES

Trouble code/ Contents of troubles	Memory function	Contents of diagnosis	Index No.
11	Provided.	<ul style="list-style-type: none"> ● Airbag main harness circuit is open, shorted or shorted to ground. ● Airbag module harness (driver) circuit is open, shorted or shorted to ground. ● Roll connector circuit is open, shorted or shorted to ground. ● Airbag control module is faulty. 	<Ref. to 5-5 [T5B0].>
12	Provided.	<ul style="list-style-type: none"> ● Airbag main harness circuit is open, shorted or shorted to ground. ● Airbag module harness (passenger) circuit is open, shorted or shorted to ground. ● Airbag control module is faulty. 	<Ref. to 5-5 [T5C0].>
15	Provided.	<ul style="list-style-type: none"> ● Airbag main harness circuit (driver) is shorted to power supply. ● Airbag module harness (driver) is shorted to power supply. ● Roll connector is shorted to power supply. ● Airbag control module is faulty. 	<Ref. to 5-5 [T5D0].>
16	Provided.	<ul style="list-style-type: none"> ● Airbag main harness circuit (passenger) is shorted to power supply. ● Airbag module harness (passenger) is shorted to power supply. ● Airbag control module is faulty. 	<Ref. to 5-5 [T5E0].>
21	Provided.	Airbag control module is faulty.	<Ref. to 5-5 [T5F0].>
22	Provided.	Front airbag module is inflated.	<Ref. to 5-5 [T5G0].>
23	Not provided.	(AB6) is not connected properly to airbag control module.	<Ref. to 5-5 [T5H0].>
24	Not provided.	<ul style="list-style-type: none"> ● Airbag control module is faulty. ● Airbag main harness circuit is open. ● Fuse No. 11 (in joint box) is blown. ● Body harness circuit is open. 	<Ref. to 5-5 [T5I0].>
25	Provided.	<ul style="list-style-type: none"> ● Airbag control module is faulty. ● Airbag main harness circuit is open. ● Fuse No. 6 (in joint box) is blown. ● Body harness circuit is open. 	<Ref. to 5-5 [T5J0].>
31	Provided.	<ul style="list-style-type: none"> ● Front sub sensor harness (RH) circuit is shorted. ● Front sub sensor harness (RH) circuit is open. ● Front sub sensor (RH) is faulty. ● Airbag control module is faulty. 	<Ref. to 5-5 [T5K0].>
32	Provided.	<ul style="list-style-type: none"> ● Front sub sensor harness (LH) circuit is shorted. ● Front sub sensor harness (LH) circuit is open. ● Front sub sensor (LH) is faulty. ● Airbag control module is faulty. 	<Ref. to 5-5 [T5L0].>
Airbag warning light remains on.	Not provided.	<ul style="list-style-type: none"> ● Airbag warning light is faulty. ● Airbag control module to airbag warning light harness circuit is shorted or open. ● Grounding circuit is faulty. ● Airbag control module is faulty. ● (AB1) and (B31) are not connected properly. ● (AB6) is not connected properly to airbag control module. 	<Ref. to 5-5 [T5M0].>

5-5 [T5A2]

SUPPLEMENTAL RESTRAINT SYSTEM

5. Diagnostics Chart with Trouble Code

Trouble code/ Contents of troubles	Memory function	Contents of diagnosis	Index No.
Airbag warning light remains off.	Not provided.	<ul style="list-style-type: none"> ● Fuse No. 18 (in joint box) is blown. ● Body harness circuit is open. ● Airbag warning light is faulty. ● Airbag main harness is faulty. ● Airbag control module is faulty. 	<Ref. to 5-5 [T5N0].>
Warning light indicates trouble code, then normal code. (Flashing trouble code.)	Provided.	Airbag system component parts are faulty.	<Ref. to 5-5 [T5O0].>
Warning light indicates trouble code, then normal code. (Flashing normal code.)	Not provided.	<ul style="list-style-type: none"> ● Airbag connector is faulty. ● Fuse No. 11 (in joint box) is blown. ● Airbag main harness is faulty. ● Airbag control module is faulty. ● Body harness is faulty. 	<Ref. to 5-5 [T5P0].>

2. HOW TO READ TROUBLE CODES

The AIRBAG warning light flashes a code corresponding to the faulty parts.

The long segment (1.2 sec on) indicates a “ten”, and the short segment (0.3 sec on) indicates a “one”.

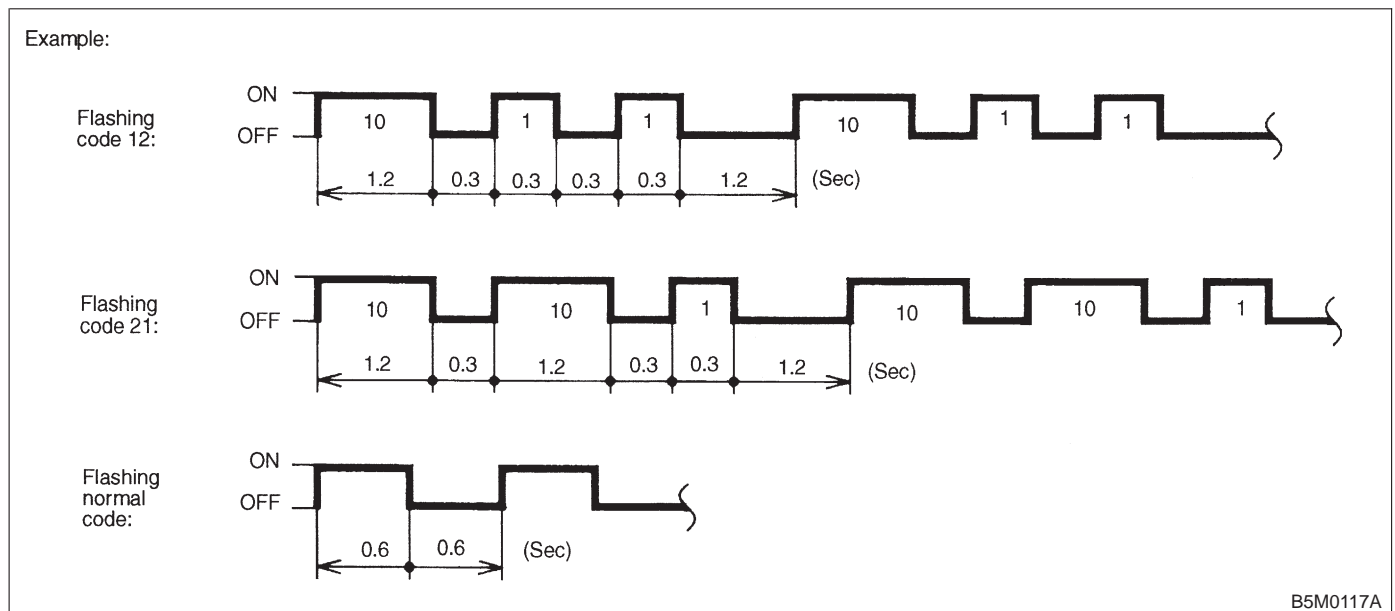

B: TROUBLE CODE 11

DIAGNOSIS:

- Airbag main harness circuit is open, shorted or shorted to ground.
- Airbag module harness (Driver) circuit is open, shorted or shorted to ground.
- Roll connector circuit is open, shorted or shorted to ground.
- Airbag control module is faulty.

CAUTION:

Before performing diagnostics on airbag system, turn ignition switch "OFF", disconnect battery ground cable and then wait at least 20 seconds.

After 20 seconds elapse, remove instrument panel lower cover, and disconnect (AB3) and (AB8), (AB9) and (AB10).

5B1 : AIRBAG MAIN HARNESS INSPECTION

1) Remove lower cover panel <Ref. to 5-4 [W1A0].>, and connect connector (AB8) below steering column to test harness F connector (1F).

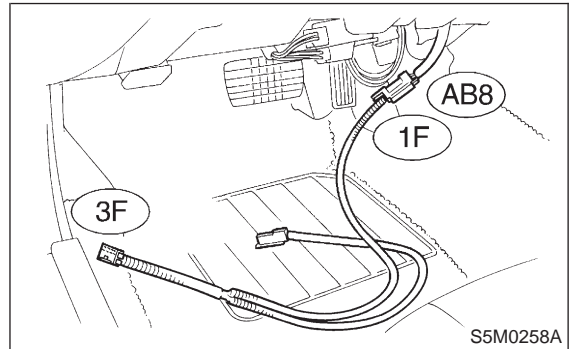

2) Disconnect connector (AB6) <Ref. to 5-5 [W5A0].> from airbag control module, and connect it to test harness I connector (1I) terminal.

3) Measure resistance between test harness I connector (2I) and test harness F connector (3F) terminals.

Connector & terminal

(2I) No. 1 — (3F) No. 3:

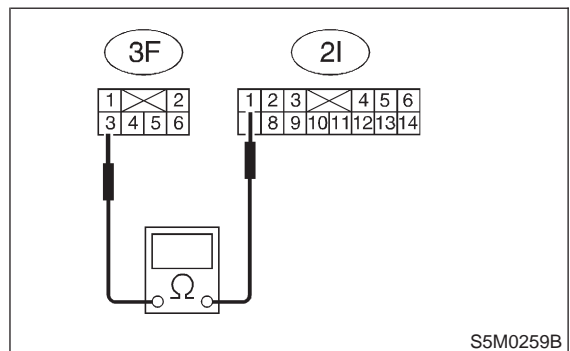

- CHECK** : Is resistance less than 10 Ω?
- YES** : Go to step 5B2.
- NO** : Replace airbag main harness. <Ref. to 5-5 [W4A0].>

5-5 [T5B2]

SUPPLEMENTAL RESTRAINT SYSTEM

5. Diagnostics Chart with Trouble Code

5B2 : AIRBAG MAIN HARNESS INSPECTION

Measure resistance between test harness I connector (2I) and test harness F connector (3F) terminals.

Connector & terminal

(2I) No. 4 — (3F) No. 4:

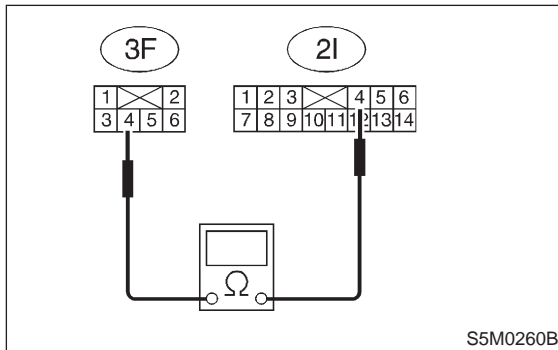

CHECK : Is resistance less than 10 Ω?

YES : Go to step 5B3.

NO : Replace airbag main harness. <Ref. to 5-5 [W4A0].>

5B3 : AIRBAG MAIN HARNESS INSPECTION

1) Disconnect connector (AB6) from airbag control module <Ref. to 5-5 [W5A0].>, and connect it to test harness I connector (1I).

2) Measure resistance between test harness I connector (2I) terminal.

Connector & terminal

(2I) No. 1 — No. 4:

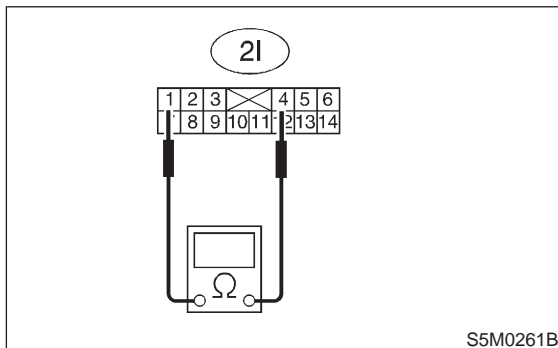

CHECK : Is resistance more than 10 kΩ?

YES : Go to step 5B4.

NO : Replace airbag main harness. <Ref. to 5-5 [W4A0].>

5B4 : AIRBAG MAIN HARNESS INSPECTION

1) Disconnect connector (AB6) from airbag control module <Ref. to 5-5 [W5A0].>, and connect it to test harness I connector (1I).

2) Measure resistance between test harness I connector (2I) terminals and chassis ground.

Connector & terminal

(2I) No. 4 (+) — Chassis ground (-):

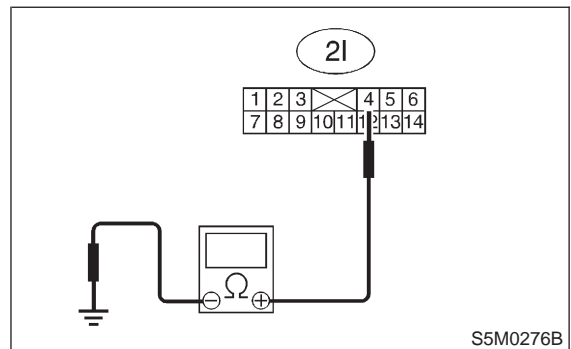

CHECK : Is resistance more than 200 Ω?

YES : Go to step 5B5.

NO : Replace airbag main harness. <Ref. to 5-5 [W4A0].>

5B5 : AIRBAG MAIN HARNESS INSPECTION

Measure resistance between test harness I connector (2I) terminals and chassis ground.

Connector & terminal

(2I) No. 1 (+) — Chassis ground (-):

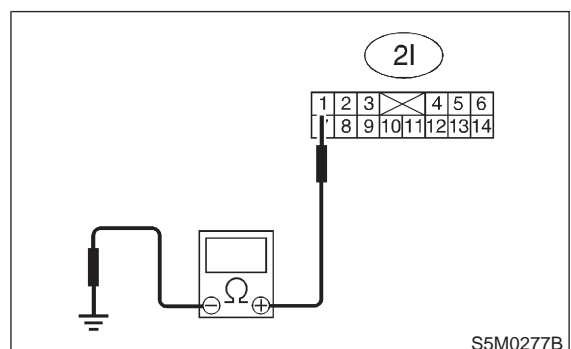

CHECK : Is resistance more than 200 Ω?

YES : Replace airbag control module. <Ref. to 5-5 [W5A0].>

NO : Replace airbag main harness. <Ref. to 5-5 [W4A0].>

C: TROUBLE CODE 12

DIAGNOSIS:

- Airbag main harness circuit is open, shorted or shorted to ground.
- Airbag module harness (Passenger) circuit is open, shorted or shorted to ground.
- Airbag control module is faulty.

CAUTION:

Before performing diagnostics on airbag system, turn ignition switch "OFF", disconnect battery ground cable and then wait at least 20 seconds.

After 20 seconds elapse, remove instrument panel lower cover, and disconnect (AB3) and (AB8), (AB9) and (AB10).

5C1 : AIRBAG MAIN HARNESS INSPECTION

- 1) Remove glove box. <Ref. to 5-4 [W1A0].>
- 2) Disconnect connector (AB9) and (AB10) <Ref. to 5-5 [W3A2].> and connect connector (AB9) to test harness F connector (1F).
- 3) Disconnect connector (AB6) <Ref. to 5-5 [W5A0].> from airbag control module, and connect it to test harness I connector (1I) terminal.
- 4) Measure resistance between test harness I connector (2I) and test harness F connector (3F) terminals.

Connector & terminal
(2I) No. 2 — (3F) No. 3:

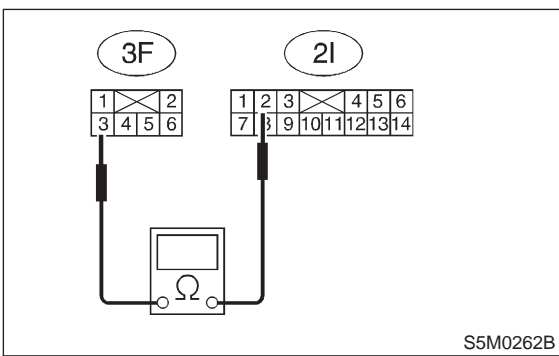

- CHECK** : Is resistance less than 10 Ω?
- YES** : Go to step 5C2.
- NO** : Replace airbag main harness. <Ref. to 5-5 [W4A0].>

5C2 : AIRBAG MAIN HARNESS INSPECTION

Measure resistance between test harness I connector (2I) and test harness F connector (3F) terminals.

Connector & terminal
(2I) No. 5 — (3F) No. 4:

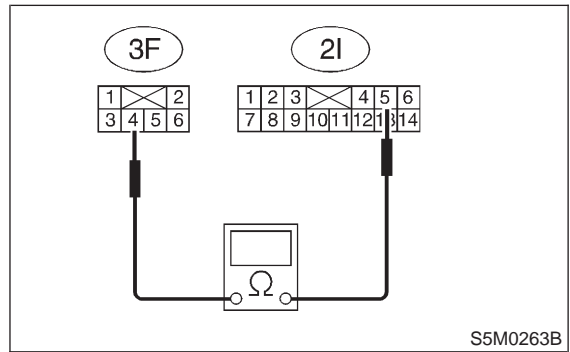

- CHECK** : Is resistance less than 10 Ω?
- YES** : Go to step 5C3.
- NO** : Replace airbag main harness. <Ref. to 5-5 [W4A0].>

5C3 : AIRBAG MAIN HARNESS INSPECTION

- 1) Disconnect connector (AB6) from airbag control module <Ref. to 5-5 [W5A0].>, and connect it to test harness I connector (1I).
- 2) Measure resistance between test harness I connector (2I) terminal.

Connector & terminal
(2I) No. 2 — No. 5:

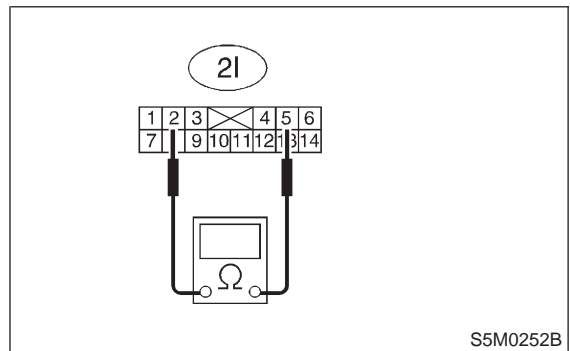

- CHECK** : Is resistance more than 10 kΩ?
- YES** : Go to step 5C4.
- NO** : Replace airbag main harness. <Ref. to 5-5 [W4A0].>

5-5 [T5C4]

SUPPLEMENTAL RESTRAINT SYSTEM

5. Diagnostics Chart with Trouble Code

5C4 : AIRBAG MAIN HARNESS INSPECTION

- 1) Disconnect connector (AB6) from airbag control module <Ref. to 5-5 [W5A0].>, and connect it to test harness I connector (1I).
- 2) Measure resistance between test harness I connector (2I) terminals and chassis ground.

Connector & terminal

(2I) No. 2 (+) — Chassis ground (-):

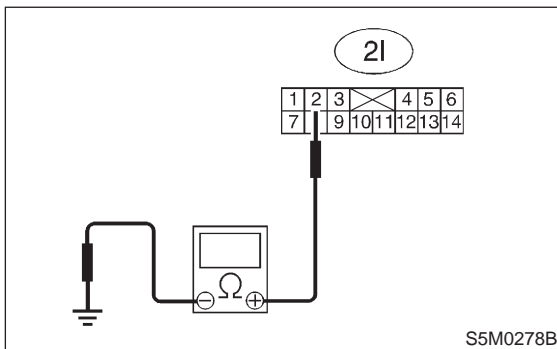

CHECK : Is resistance more than 200 Ω?

YES : Go to step 5C5.

NO : Replace airbag main harness. <Ref. to 5-5 [W4A0].>

5C5 : AIRBAG MAIN HARNESS INSPECTION

Measure resistance between test harness I connector (2I) terminals and chassis ground.

Connector & terminal

(2I) No. 5 (+) — Chassis ground (-):

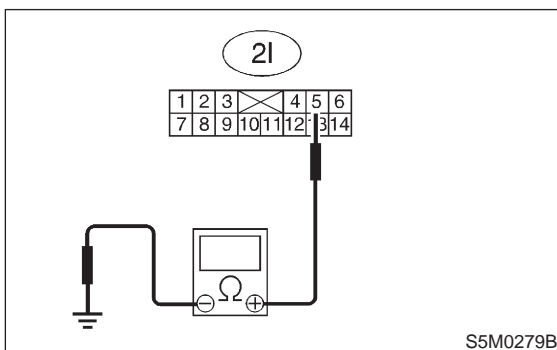

CHECK : Is resistance more than 200 Ω?

YES : Replace airbag control module. <Ref. to 5-5 [W5A0].>

NO : Replace airbag main harness. <Ref. to 5-5 [W4A0].>

D: TROUBLE CODE 15

DIAGNOSIS:

- Airbag main harness circuit (Driver) is shorted to power supply.
- Airbag module harness (Driver) is shorted to power supply.
- Roll connector is shorted to power supply.
- Airbag control module is faulty.

CAUTION:

Before performing diagnostics on airbag system, turn ignition switch "OFF", disconnect battery ground terminal and then wait at least 20 seconds.

After 20 seconds elapse, remove instrument panel lower cover, and disconnect (AB3) and (AB8), (AB9) and (AB10).

5D1 : AIRBAG MAIN HARNESS INSPECTION

- 1) Disconnect connector (AB6) from airbag control module <Ref. to 5-5 [W5A0].>, and connect it to test harness I connector (1I).
- 2) Connect battery ground cable and turn ignition switch "ON" (engine off).
- 3) Measure voltage across each test harness I connector (2I) terminal and chassis ground.

Connector & terminal

(2I) No. 4 (+) — Chassis ground (-):

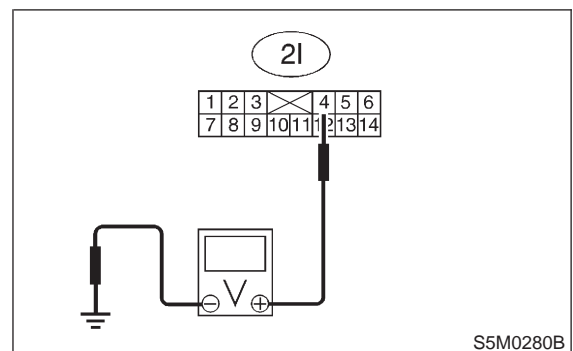

CHECK : Is voltage less than 1 V?

YES : Go to step 5D2.

NO : Replace airbag main harness. <Ref. to 5-5 [W4A0].>

5D2 : AIRBAG MAIN HARNESS INSPECTION

Measure voltage across each test harness I connector (2I) terminal and chassis ground.

Connector & terminal

(2I) No. 1 (+) — Chassis ground (-):

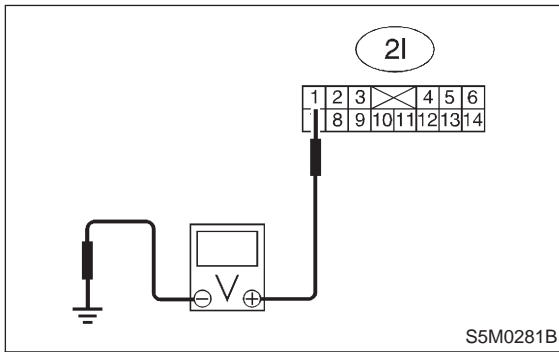

- CHECK** : **Is voltage less than 1 V?**
- YES** : Replace airbag control module. <Ref. to 5-5 [W5A0].>
- NO** : Replace airbag main harness. <Ref. to 5-5 [W4A0].>

E: TROUBLE CODE 16

DIAGNOSIS:

- Airbag main harness circuit (Passenger) is shorted to power supply.
- Airbag module harness (Passenger) is shorted to power supply.
- Airbag control module is faulty.

CAUTION:

Before performing diagnostics on airbag system, turn ignition switch “OFF”, disconnect battery ground terminal and then wait at least 20 seconds.

After 20 seconds elapse, remove instrument panel lower cover, and disconnect (AB3) and (AB8), (AB9) and (AB10).

5E1 : AIRBAG MAIN HARNESS INSPECTION

- 1) Disconnect connector (AB6) from airbag control module <Ref. to 5-5 [W5A0].>, and connect it to test harness I connector (1I).
- 2) Connect battery ground cable and turn ignition switch “ON” (engine off).
- 3) Measure voltage across each test harness I connector (2I) terminal and chassis ground.

Connector & terminal

(2I) No. 2 (+) — Chassis ground (-):

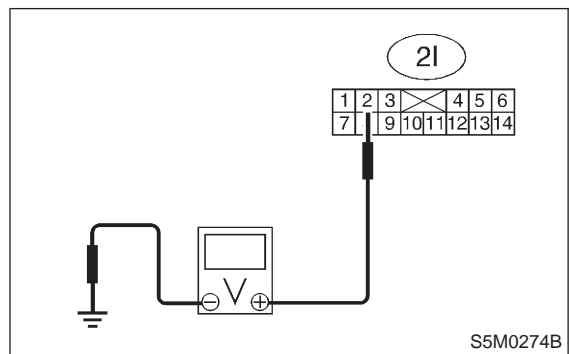

- CHECK** : **Is voltage less than 1 V?**
- YES** : Go to step **5E2**.
- NO** : Replace airbag main harness. <Ref. to 5-5 [W4A0].>

5-5 [T5E2]

SUPPLEMENTAL RESTRAINT SYSTEM

5. Diagnostics Chart with Trouble Code

5E2 : AIRBAG MAIN HARNESS INSPECTION

Measure voltage across each test harness I connector (2I) terminal and chassis ground.

Connector & terminal

(2I) No. 5 (+) — Chassis ground (-):

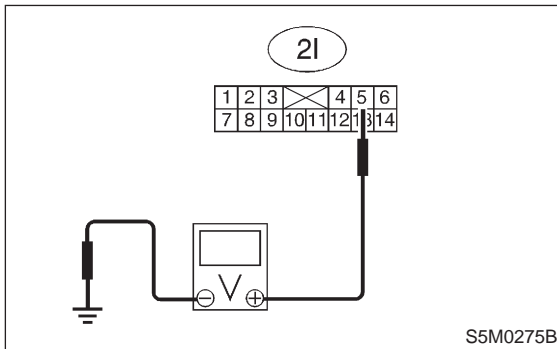

- CHECK** : **Is voltage less than 1 V?**
- YES** : Replace airbag control module. <Ref. to 5-5 [W5A0].>
- NO** : Replace airbag main harness. <Ref. to 5-5 [W4A0].>

F: TROUBLE CODE 21

DIAGNOSIS:

Airbag control module is faulty.

CAUTION:

Before performing diagnostics on airbag system, turn ignition switch "OFF", disconnect battery ground terminal, and then wait at least 20 seconds.

5F1 : CHECK IF TROUBLE CODE 21 IS INDICATED.

Confirm flashing trouble code according to "BASIC DIAGNOSTICS PROCEDURE". <Ref. to 5-5 [T4A0].>

- CHECK** : **Is airbag warning light trouble code 21 indicated?**
- YES** : Replace airbag control module. <Ref. to 5-5 [W5A0].>
- NO** : Perform clear memory. <Ref. to 5-5 [T4C0].>

G: TROUBLE CODE 22

DIAGNOSIS:

Front airbag module is inflated.

CAUTION:

Before performing diagnostics on airbag system, turn ignition switch "OFF", disconnect battery ground terminal, and then wait at least 20 seconds.

5G1 : CHECK IF TROUBLE CODE 22 IS INDICATED.

Confirm flashing trouble code according to "BASIC DIAGNOSTICS PROCEDURE". <Ref. to 5-5 [T4A0].>

- CHECK** : *Is airbag warning light trouble code 22 indicated?*
- YES** : Replace airbag control module <Ref. to 5-5 [W5A0].>, front sub sensor <Ref. to 5-5 [W7A0].>, driver's airbag module <Ref. to 5-5 [W3A1].> and passenger's airbag module. <Ref. to 5-5 [W3A2].>
- NO** : Perform clear memory. <Ref. to 5-5 [T4C0].>

H: TROUBLE CODE 23

DIAGNOSIS:

(AB6) is not connected properly to airbag control module.

CAUTION:

Before performing diagnostics on airbag system, turn ignition switch "OFF", disconnect battery ground cable and then wait at least 20 seconds.

5H1 : CHECK POOR CONTACT IN CONNECTOR (AB6).

Check connector (AB6) connected to airbag control module. <Ref. to 5-5 [W5A0].>

- CHECK** : *Is there poor contact in connector (AB6)?*
- YES** : Repair poor contact in connector (AB6).
- NO** : Replace airbag control module. <Ref. to 5-5 [W5A0].>

I: TROUBLE CODE 24

DIAGNOSIS:

- Airbag control module is faulty.
- Airbag main harness circuit is open.
- Fuse No. 11 (in joint box) is blown.
- Body harness circuit is open.

CAUTION:

Before performing diagnostics on airbag system, turn ignition switch "OFF", disconnect battery ground cable and then wait at least 20 seconds.

After 20 seconds elapse, remove instrument panel lower cover, and disconnect (AB3) and (AB8), (AB9) and (AB10).

511 : AIRBAG CONTROL MODULE INSPECTION

- 1) Disconnect connector (AB6) from airbag control module <Ref. to 5-5 [W5A0].>, and connect it to test harness I connector (1I).
- 2) Connect battery ground cable and turn ignition switch "ON" (engine off).
- 3) Measure voltage across connector (2I) terminal and chassis ground.

Connector & terminal

(2I) No. 3 (+) — Chassis ground (-):

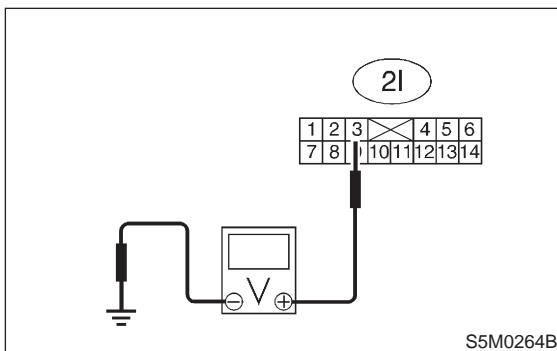

- CHECK** : **Is voltage more than 10 V?**
- YES** : Replace airbag control module. <Ref. to 5-5 [W5A0].>
- NO** : Go to step **512**.

512 : AIRBAG MAIN HARNESS INSPECTION

- 1) Go to following procedure after performing diagnostics on airbag system as per diagnosis procedure under "511 AIRBAG CONTROL MODULE INSPECTION" <Ref. to 5-5 [T511].> previously outlined.
- 2) Turn ignition switch "OFF", disconnect battery ground cable and then wait at least 20 seconds.
- 3) Disconnect connector (AB1) from body harness connector (B31) at front lower pillar (driver side), and connect connector (AB1) to test harness A connector (2A).
- 4) Measure resistance between test harness A connector (5A) and test harness I connector (2I) terminals.

Connector & terminal

(5A) No. 9 — (2I) No. 3:

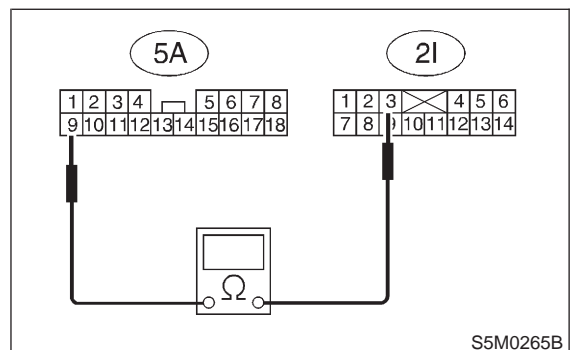

- CHECK** : **Is resistance less than 10 Ω?**
- YES** : Go to step **513**.
- NO** : Replace airbag main harness. <Ref. to 5-5 [W4A0].>

5I3 : AIRBAG MAIN HARNESS INSPECTION

Measure resistance between each terminal of connectors (5A) and chassis ground.

Connector & terminal

(5A) No. 9 (+) — Chassis ground (-):

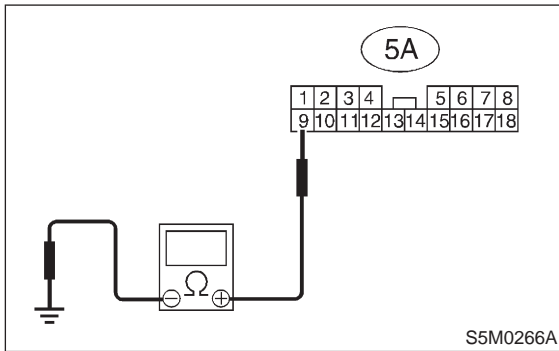

- CHECK** : **Is resistance more than 10 kΩ?**
- YES** : Go to step **5I4**.
- NO** : Replace airbag main harness. <Ref. to 5-5 [W4A0].>

5I4 : AIRBAG MAIN HARNESS INSPECTION

Measure resistance between each terminal of connectors (2I) and chassis ground.

Connector & terminal

(2I) No. 3 (+) — Chassis ground (-):

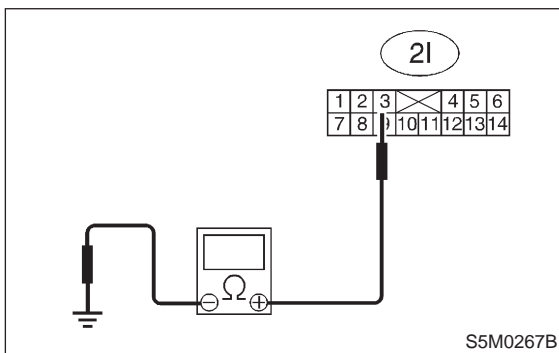

- CHECK** : **Is resistance more than 10 kΩ?**
- YES** : Go to step **5I5**.
- NO** : Replace airbag main harness. <Ref. to 5-5 [W4A0].>

5I5 : FUSE NO. 11 (IN JOINT BOX) INSPECTION

Make sure ignition switch is turned "OFF", then remove and visually check fuse No. 11 (in joint box).

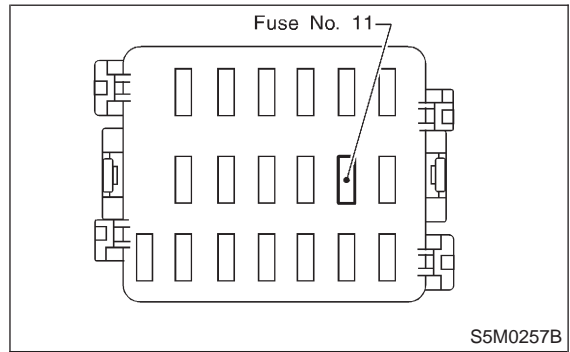

- CHECK** : **Is fuse No. 11 blown?**
- YES** : Replace fuse No. 11. If fuse No. 11 blows again, repair body harness.
- NO** : Repair body harness.

J: TROUBLE CODE 25

DIAGNOSIS:

- Airbag control module is faulty.
- Airbag main harness circuit is open.
- Fuse No. 6 (in joint box) is blown.
- Body harness circuit is open.

CAUTION:

Before performing diagnostics on airbag system, turn ignition switch "OFF", disconnect battery ground cable and then wait at least 20 seconds.

After 20 seconds elapse, remove instrument panel lower cover, and disconnect (AB3) and (AB8), (AB9) and (AB10).

5J1 : AIRBAG CONTROL MODULE INSPECTION

- 1) Disconnect connector (AB6) from airbag control module <Ref. to 5-5 [W5A0].> and connect it to test harness I connector (1I).
- 2) Connect battery ground cable and turn ignition switch "ON". (engine off)
- 3) Measure voltage across connector (2I) terminal and chassis ground.

Connector & terminal

(2I) No. 6 (+) — Chassis ground (-):

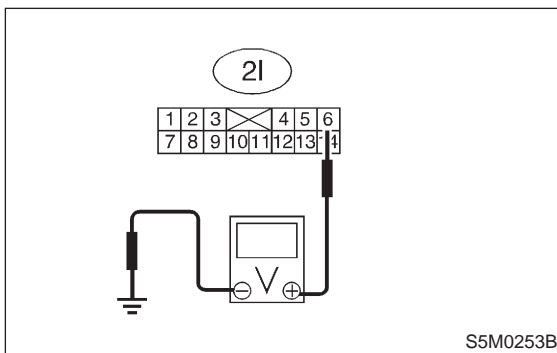

- CHECK** : **Is voltage more than 10 V?**
- YES** : Replace airbag control module. <Ref. to 5-5 [W5A0].>
- NO** : Go to step **5J2**.

5J2 : AIRBAG MAIN HARNESS INSPECTION

- 1) Go to following procedure after performing diagnostics on airbag system as per diagnosis procedure under "5J1 AIRBAG CONTROL MODULE INSPECTION" <Ref. to 5-5 [T5J1].> previously outlined.
- 2) Turn ignition switch "OFF", disconnect battery ground terminal and then wait at least 20 seconds.
- 3) Disconnect body harness connector (B31) from connector (AB1) at front lower pillar, and connect connector (AB1) to test harness A connector (2A).

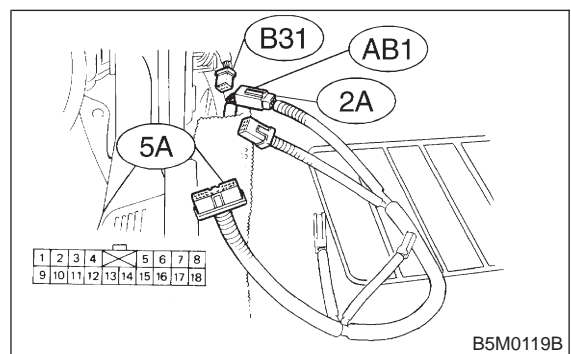

- 4) Measure resistance between test harness A connector (5A) terminal and test harness I connector (2I) terminal.

Connector & terminal

(5A) No. 1 — (2I) No. 6:

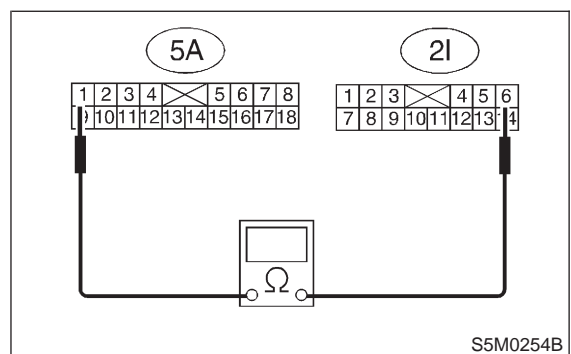

- CHECK** : **Is resistance less than 10 Ω?**
- YES** : Go to step **5J3**.
- NO** : Replace airbag main harness. <Ref. to 5-5 [W4A0].>

5J3 : AIRBAG MAIN HARNESS INSPECTION

Measure resistance between (5A) connector terminal and chassis ground.

Connector & terminal

(5A) No. 1 (+) — Chassis ground (-):

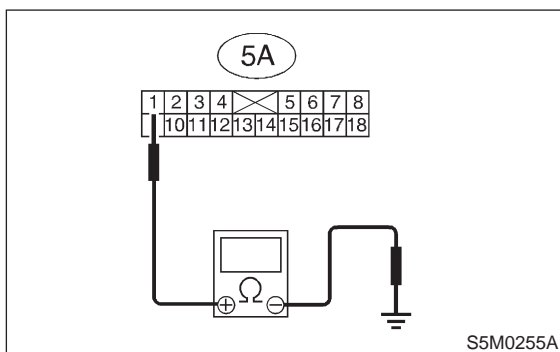

- CHECK** : Is resistance more than 10 kΩ?
- YES** : Go to step 5J4.
- NO** : Replace airbag main harness. <Ref. to 5-5 [W4A0].>

5J4 : AIRBAG MAIN HARNESS INSPECTION

Measure resistance between (2I) connector terminal and chassis ground.

Connector & terminal

(2I) No. 6 (+) — Chassis ground (-):

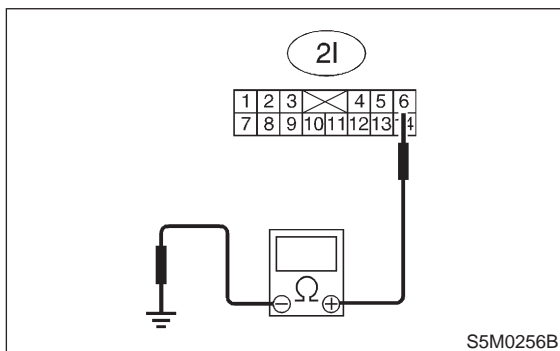

- CHECK** : Is resistance more than 10 kΩ?
- YES** : Go to step 5J5.
- NO** : Replace airbag main harness. <Ref. to 5-5 [W4A0].>

5J5 : FUSE NO. 6 (IN JOINT BOX) INSPECTION

- 1) Turn ignition switch "OFF".
- 2) Remove and visually check fuse No. 6 (in joint box).

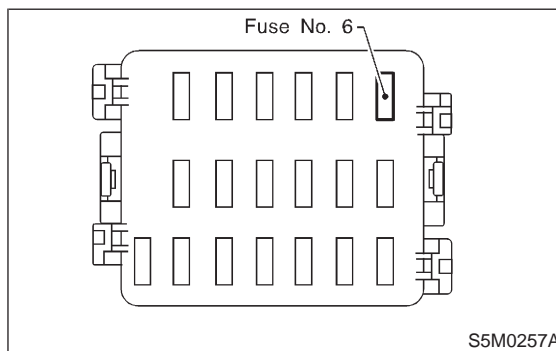

- CHECK** : Is fuse No. 6 blown?
- YES** : Replace fuse No. 6 if fuse No. 6 blows again, repair body harness.
- NO** : Repair body harness.

K: TROUBLE CODE 31

DIAGNOSIS:

- Front sub sensor harness (RH) circuit is shorted.
- Front sub sensor harness (RH) circuit is open.
- Front sub sensor (RH) is faulty.
- Airbag control module is faulty.

CAUTION:

Before performing diagnostics on airbag system, turn ignition switch "OFF", disconnect battery ground terminal, and then wait at least 20 seconds.

5K1 : FRONT SUB SENSOR (RH) AND FRONT SUB SENSOR HARNESS (RH) INSPECTION

- 1) Disconnect connector (AB6) from airbag control module <Ref. to 5-5 [W5A0].>, and connect it to test harness I connector (1I).
- 2) Measure resistance between test harness I connector (3I) terminal.

Connector & terminal
(3I) No. 2 — No. 4:

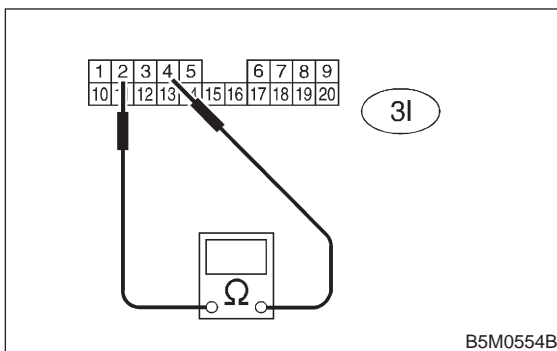

- CHECK** : Is the resistance between 750 Ω and 1 kΩ?
- YES** : Replace airbag control module. <Ref. to 5-5 [W5A0].>
- NO** : Go to step 5K2.

5K2 : FRONT SUB SENSOR (RH) AND FRONT SUB SENSOR HARNESS (RH) INSPECTION

Measure resistance across test harness I connector (3I) terminal and chassis ground.

Connector & terminal
(3I) No. 2 (+) — Chassis ground (-):

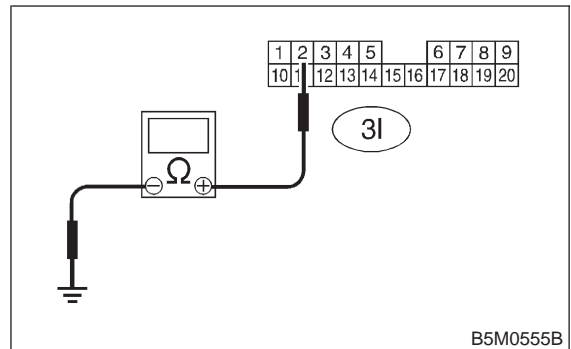

- CHECK** : Is the resistance more than 10 kΩ?
- YES** : Replace airbag control module. <Ref. to 5-5 [W5A0].>
- NO** : Go to step 5K3.

5K3 : FRONT SUB SENSOR (RH) AND FRONT SUB SENSOR HARNESS (RH) INSPECTION

Measure resistance across test harness I connector (3I) terminal and chassis ground.

Connector & terminal
(3I) No. 4 (+) — Chassis ground (-):

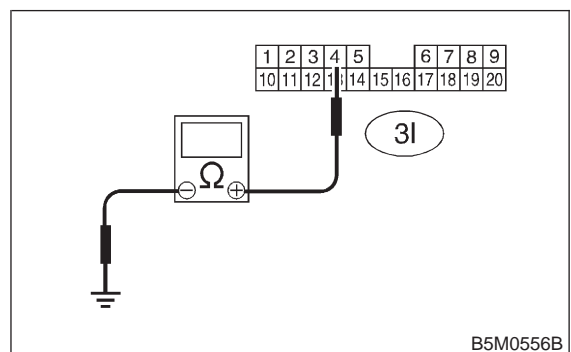

- CHECK** : Is the resistance more than 10 kΩ?
- YES** : Replace airbag control module. <Ref. to 5-5 [W5A0].>
- NO** : Go to step 5K4.

5K4 : AIRBAG MAIN HARNESS INSPECTION

1) Disconnect connector (AB14) and (AB15), then connect test harness F connector (2F) and connector (AB14).
 2) Measure resistance between test harness I connector (3I) terminal and test harness F connector (3F) terminal.

Connector & terminal
(3I) No. 2 — (3F) No. 6:

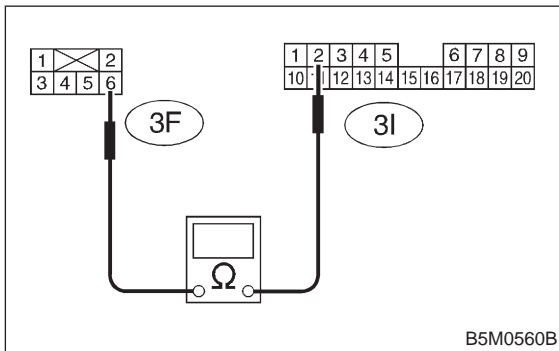

- CHECK** : Is the resistance less than 10 Ω?
- YES** : Go to step 5K5.
- NO** : Replace airbag main harness. <Ref. to 5-5 [W4A0].>

5K5 : AIRBAG MAIN HARNESS INSPECTION

Measure resistance between test harness I connector (3I) terminal and test harness F connector (3F) terminal.

Connector & terminal
(3I) No. 4 — (3F) No. 5:

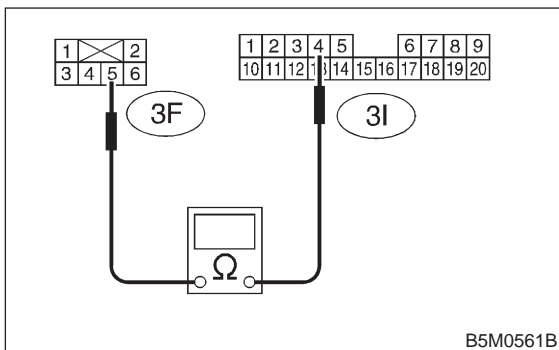

- CHECK** : Is the resistance less than 10 Ω?
- YES** : Go to step 5K6.
- NO** : Replace airbag main harness. <Ref. to 5-5 [W4A0].>

5K6 : AIRBAG MAIN HARNESS INSPECTION

Measure resistance across test harness I connector (3I) terminal and chassis ground.

Connector & terminal
(3I) No. 2 (+) — Chassis ground (-):

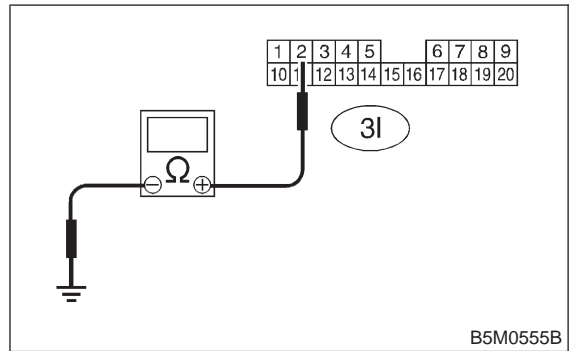

- CHECK** : Is the resistance more than 10 kΩ?
- YES** : Go to step 5K7.
- NO** : Replace airbag main harness. <Ref. to 5-5 [W4A0].>

5K7 : AIRBAG MAIN HARNESS INSPECTION

Measure resistance across test harness I connector (3I) terminal and chassis ground.

Connector & terminal
(3I) No. 4 (+) — Chassis ground (-):

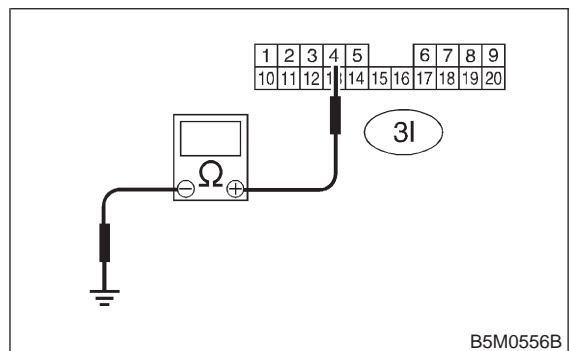

- CHECK** : Is the resistance more than 10 kΩ?
- YES** : Go to step 5K8.
- NO** : Replace airbag main harness. <Ref. to 5-5 [W4A0].>

5-5 [T5K8]

SUPPLEMENTAL RESTRAINT SYSTEM

5. Diagnostics Chart with Trouble Code

5K8 : FRONT SUB SENSOR HARNESS (RH) INSPECTION

- 1) Connect test harness F connector (1F) and connector (AB15).
- 2) Disconnect connector (AB16) from front sub sensor (RH) <Ref. to 5-5 [W7A0].> and then test harness H connector (1H) and connector (AB16).
- 3) Measure resistance between test harness F connector (3F) terminal and test harness H connector (3H) terminal.

Connector & terminal

(3F) No. 3 — (3H) No. 5:

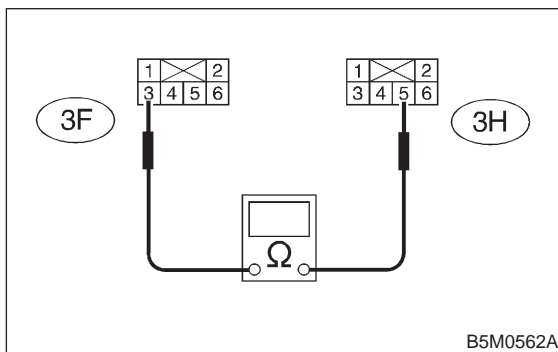

- CHECK** : Is the resistance less than 10 Ω ?
- YES** : Go to step 5K9.
- NO** : Replace front sub sensor harness (RH). <Ref. to 5-5 [W7A0].>

5K9 : FRONT SUB SENSOR HARNESS (RH) INSPECTION

Measure resistance between test harness F connector (3F) terminal and test harness H connector (3H) terminal.

Connector & terminal

(3F) No. 4 — (3H) No. 6:

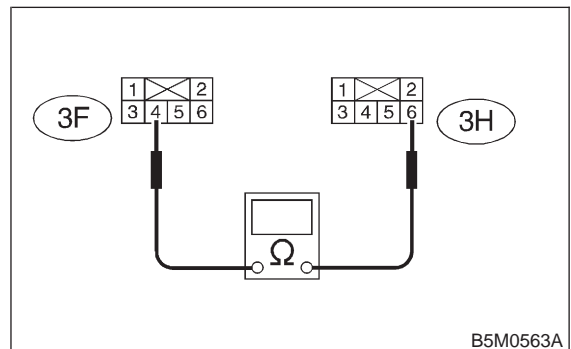

- CHECK** : Is the resistance less than 10 Ω ?
- YES** : Go to step 5K10.
- NO** : Replace front sub sensor harness (RH). <Ref. to 5-5 [W7A0].>

5K10 : FRONT SUB SENSOR HARNESS (RH) INSPECTION

Measure resistance across test harness F connector (3F) terminal and chassis ground.

Connector & terminal

(3F) No. 3 (+) — Chassis ground (-):

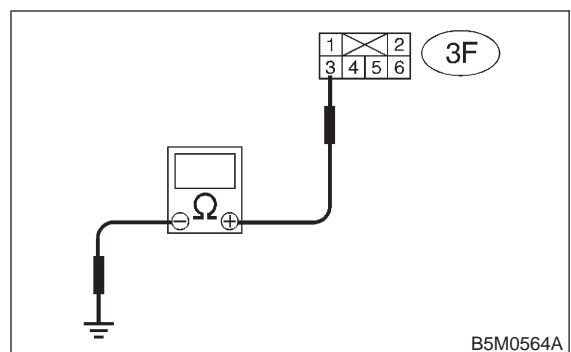

- CHECK** : Is the resistance more than 10 k Ω ?
- YES** : Go to step 5K11.
- NO** : Replace front sub sensor harness (RH). <Ref. to 5-5 [W7A0].>

5K11 : FRONT SUB SENSOR HARNESS (RH) INSPECTION

Measure resistance across test harness F connector (3F) terminal and chassis ground.

Connector & terminal

(3F) No. 4 (+) — Chassis ground (-):

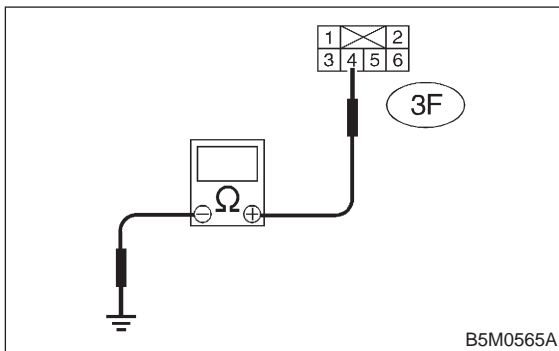

- CHECK** : Is the resistance more than 10 kΩ?
- YES** : Go to step 5K12.
- NO** : Replace front sub sensor harness (RH). <Ref. to 5-5 [W7A0].>

5K12 : FRONT SUB SENSOR (RH) INSPECTION

- 1) Connect test harness H connector (2H) and front sub sensor (RH).
- 2) Measure resistance between test harness H connector (3H) terminal.

Connector & terminal

(3H) No. 3 — No. 4:

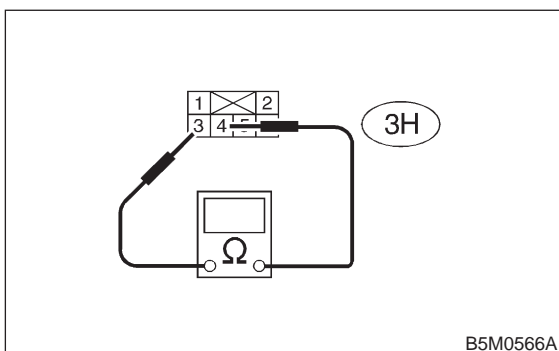

- CHECK** : Is the resistance between 750 Ω and 1 kΩ?
- YES** : Go to step 5K13.
- NO** : Replace front sub sensor (RH). <Ref. to 5-5 [W7A0].>

5K13 : FRONT SUB SENSOR (RH) INSPECTION

Measure resistance across test harness H connector (3H) terminal and chassis ground.

Connector & terminal

(3H) No. 3 (+) — Chassis ground (-):

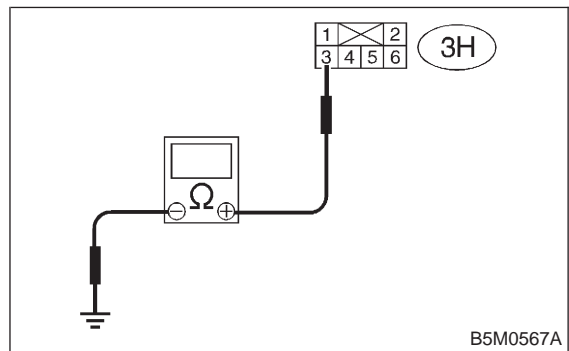

- CHECK** : Is the resistance less than 10 kΩ?
- YES** : Go to step 5K14.
- NO** : Replace front sub sensor (RH). <Ref. to 5-5 [W7A0].>

5K14 : FRONT SUB SENSOR (RH) INSPECTION

Measure resistance across test harness H connector (3H) terminal and chassis ground.

Connector & terminal

(3H) No. 4 (+) — Chassis ground (-):

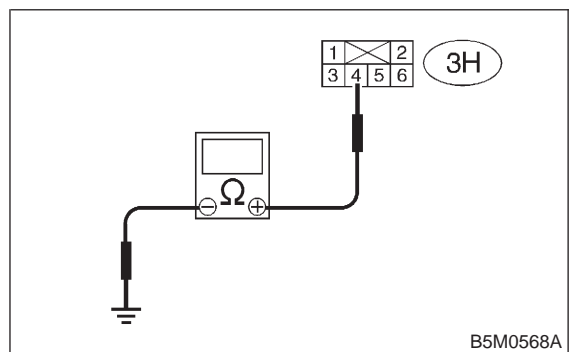

- CHECK** : Is the resistance less than 10 kΩ?
- YES** : Perform clear memory. <Ref. to 5-5 [T4C0].>
- NO** : Replace front sub sensor (RH). <Ref. to 5-5 [W7A0].>

L: TROUBLE CODE 32

DIAGNOSIS:

- Front sub sensor harness (LH) circuit is shorted.
- Front sub sensor harness (LH) circuit is open.
- Front sub sensor (LH) is faulty.
- Airbag control module is faulty.

CAUTION:

Before performing diagnostics on airbag system, turn ignition switch "OFF", disconnect battery ground terminal, and then wait at least 20 seconds.

5L1 : FRONT SUB SENSOR (LH) AND FRONT SUB SENSOR HARNESS (LH) INSPECTION

- 1) Disconnect connector (AB6) from airbag control module <Ref. to 5-5 [W5A0].>, and connect it to test harness I connector (1I).
- 2) Measure resistance between test harness I connector (3I) terminal.

Connector & terminal
(3I) No. 1 — No. 3:

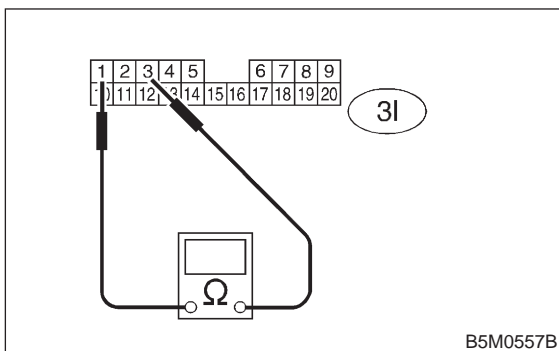

- CHECK** : Is the resistance between 750 Ω and 1 kΩ?
- YES** : Replace airbag control module. <Ref. to 5-5 [W5A0].>
- NO** : Go to step 5L2.

5L2 : FRONT SUB SENSOR (LH) AND FRONT SUB SENSOR HARNESS (LH) INSPECTION

Measure resistance across test harness I connector (3I) terminal and chassis ground.

Connector & terminal

(3I) No. 1 (+) — Chassis ground (-):

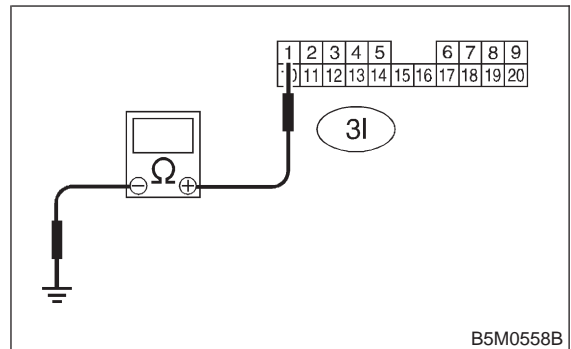

- CHECK** : Is the resistance more than 10 kΩ?
- YES** : Replace airbag control module. <Ref. to 5-5 [W5A0].>
- NO** : Go to step 5L3.

5L3 : FRONT SUB SENSOR (LH) AND FRONT SUB SENSOR HARNESS (LH) INSPECTION

Measure resistance across test harness I connector (3I) terminal and chassis ground.

Connector & terminal

(3I) No. 3 (+) — Chassis ground (-):

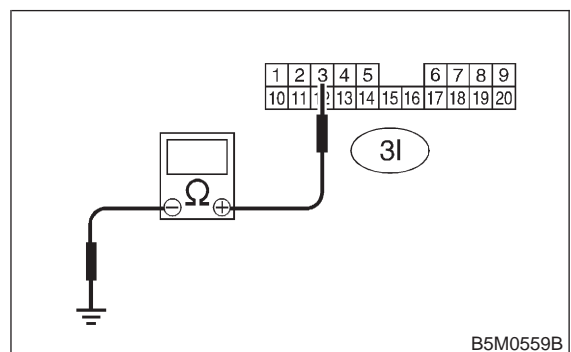

- CHECK** : Is the resistance more than 10 kΩ?
- YES** : Replace airbag control module. <Ref. to 5-5 [W5A0].>
- NO** : Go to step 5L4.

5L4 : AIRBAG MAIN HARNESS INSPECTION

1) Disconnect connector (AB11) and (AB12), then connect test harness F connector (2F) and connector (AB11).
 2) Measure resistance between test harness I connector (3I) terminal and test harness F connector (3F) terminal.

Connector & terminal
(3I) No. 3 — (3F) No. 6:

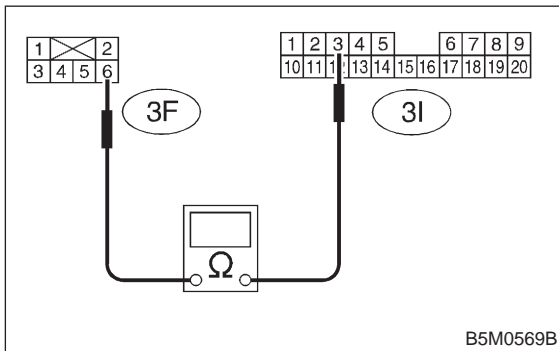

- CHECK** : Is the resistance less than 10 Ω?
- YES** : Go to step 5L5.
- NO** : Replace airbag main harness. <Ref. to 5-5 [W4A0].>

5L5 : AIRBAG MAIN HARNESS INSPECTION

Measure resistance between test harness I connector (3I) terminal and test harness F connector (3F) terminal.

Connector & terminal
(3I) No. 1 — (3F) No. 5:

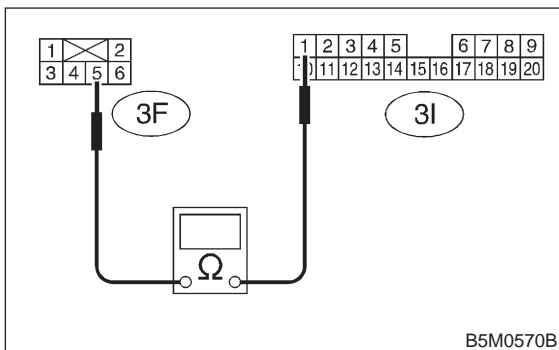

- CHECK** : Is the resistance less than 10 Ω?
- YES** : Go to step 5L6.
- NO** : Replace airbag main harness. <Ref. to 5-5 [W4A0].>

5L6 : AIRBAG MAIN HARNESS INSPECTION

Measure resistance across test harness I connector (3I) terminal and chassis ground.

Connector & terminal
(3I) No. 3 (+) — Chassis ground (-):

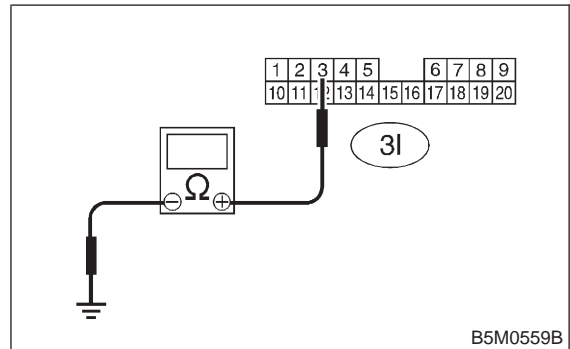

- CHECK** : Is the resistance more than 10 kΩ?
- YES** : Go to step 5L7.
- NO** : Replace airbag main harness. <Ref. to 5-5 [W4A0].>

5L7 : AIRBAG MAIN HARNESS INSPECTION

Measure resistance across test harness I connector (3I) terminal and chassis ground.

Connector & terminal
(3I) No. 1 (+) — Chassis ground (-):

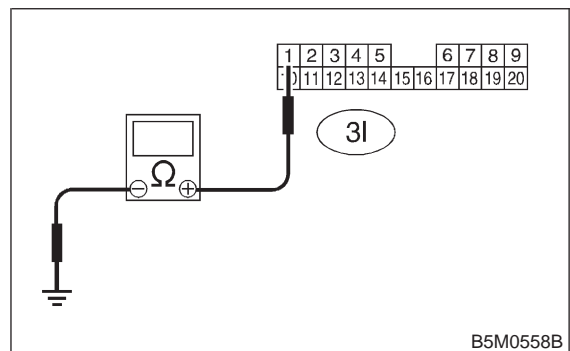

- CHECK** : Is the resistance more than 10 kΩ?
- YES** : Go to step 5L8.
- NO** : Replace airbag main harness. <Ref. to 5-5 [W4A0].>

5-5 [T5L8]

SUPPLEMENTAL RESTRAINT SYSTEM

5. Diagnostics Chart with Trouble Code

5L8 : FRONT SUB SENSOR HARNESS (LH) INSPECTION

- 1) Connect test harness F connector (1F) and connector (AB12).
- 2) Disconnect connector (AB13) from front sub sensor (LH) <Ref. to 5-5 [W7A0].> and then test harness H connector (1H) and connector (AB13).
- 3) Measure resistance between test harness F connector (3F) terminal and test harness H connector (3H) terminal.

Connector & terminal

(3F) No. 3 — (3H) No. 5:

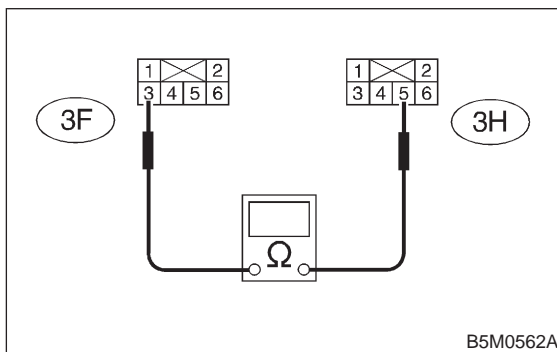

- CHECK** : Is the resistance less than 10 Ω?
- YES** : Go to step 5L9.
- NO** : Replace front sub sensor harness (LH). <Ref. to 5-5 [W7A0].>

5L9 : FRONT SUB SENSOR HARNESS (LH) INSPECTION

Measure resistance between test harness F connector (3F) terminal and test harness H connector (3H) terminal.

Connector & terminal

(3F) No. 4 — (3H) No. 6:

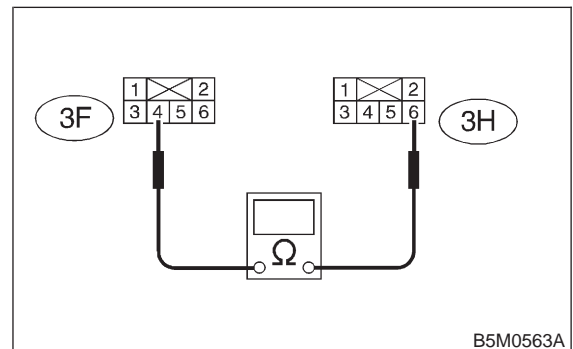

- CHECK** : Is the resistance less than 10 Ω?
- YES** : Go to step 5L10.
- NO** : Replace front sub sensor harness (LH). <Ref. to 5-5 [W7A0].>

5L10 : FRONT SUB SENSOR HARNESS (LH) INSPECTION

Measure resistance across test harness F connector (3F) terminal and chassis ground.

Connector & terminal

(3F) No. 3 (+) — Chassis ground (-):

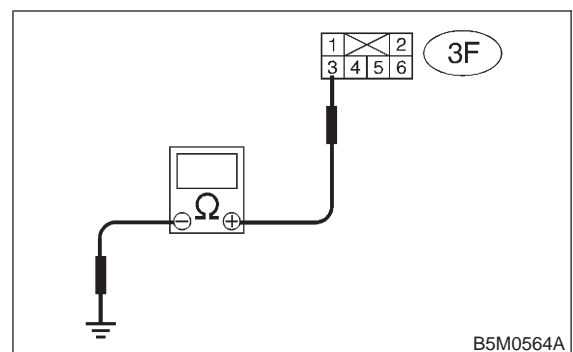

- CHECK** : Is the resistance more than 10 kΩ?
- YES** : Go to step 5L11.
- NO** : Replace front sub sensor harness (LH). <Ref. to 5-5 [W7A0].>

5L11 : FRONT SUB SENSOR HARNESS (LH) INSPECTION

Measure resistance across test harness F connector (3F) terminal and chassis ground.

Connector & terminal
(3F) No. 4 (+) — Chassis ground (-):

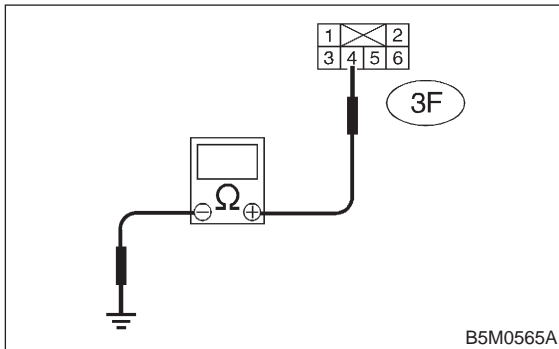

- CHECK** : Is the resistance more than 10 kΩ?
- YES** : Go to step 5L12.
- NO** : Replace front sub sensor harness (LH). <Ref. to 5-5 [W7A0].>

5L12 : FRONT SUB SENSOR (LH) INSPECTION

- 1) Connect test harness H connector (2H) and front sub sensor (LH).
- 2) Measure resistance between test harness H connector (3H) terminal.

Connector & terminal
(3H) No. 3 — No. 4:

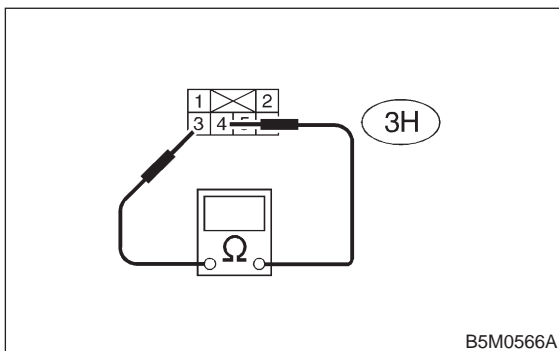

- CHECK** : Is the resistance between 750 Ω and 1 kΩ?
- YES** : Go to step 5L13.
- NO** : Replace front sub sensor (LH). <Ref. to 5-5 [W7A0].>

5L13 : FRONT SUB SENSOR (LH) INSPECTION

Measure resistance across test harness H connector (3H) terminal and chassis ground.

Connector & terminal
(3H) No. 3 (+) — Chassis ground (-):

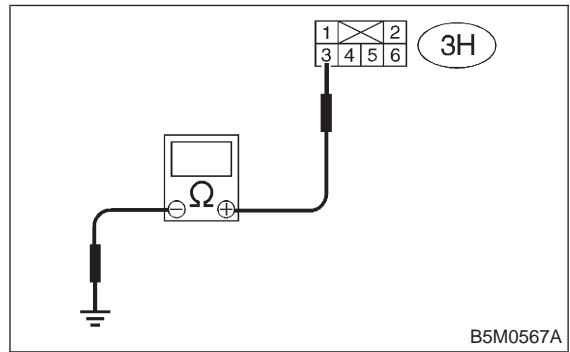

- CHECK** : Is the resistance less than 10 kΩ?
- YES** : Go to step 5L14.
- NO** : Replace front sub sensor (LH). <Ref. to 5-5 [W7A0].>

5L14 : FRONT SUB SENSOR (LH) INSPECTION

Measure resistance across test harness H connector (3H) terminal and chassis ground.

Connector & terminal
(3H) No. 4 (+) — Chassis ground (-):

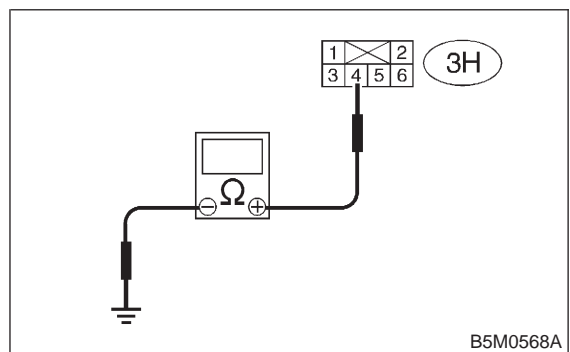

- CHECK** : Is the resistance less than 10 kΩ?
- YES** : Perform clear memory. <Ref. to 5-5 [T4C0].>
- NO** : Replace front sub sensor (LH). <Ref. to 5-5 [W7A0].>

M: AIRBAG WARNING LIGHT REMAINS ON.

DIAGNOSIS:

- Airbag warning light is faulty.
- Airbag control module to airbag warning light harness circuit is shorted or open.
- Grounding circuit is faulty.
- Airbag control module is faulty.
- (AB1) and (B31) are not connected properly.
- (AB6) is not connected properly to airbag control module.

CAUTION:

Before performing diagnostics on airbag system, turn ignition switch "OFF", disconnect battery ground cable and then wait at least 20 seconds.

5M1 : CHECK POOR CONTACT IN CONNECTORS (AB1) AND (B31).

- 1) Remove front pillar lower trim (Driver side).
- 2) Check poor contact in connectors (AB1) and (B31).

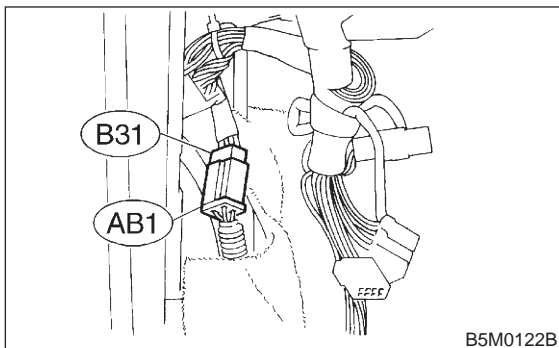

- CHECK** : *Is there poor contact in double lock of connectors (AB1) and (B31)?*
- YES** : Repair poor contact in double lock of connectors (AB1) and (B31).
- NO** : Go to step **5M2**.

5M2 : INSPECTION OF AIRBAG WARNING LIGHT

- 1) Turn ignition switch "OFF" and connect body harness connector (B31) to test connector A connector (1A).

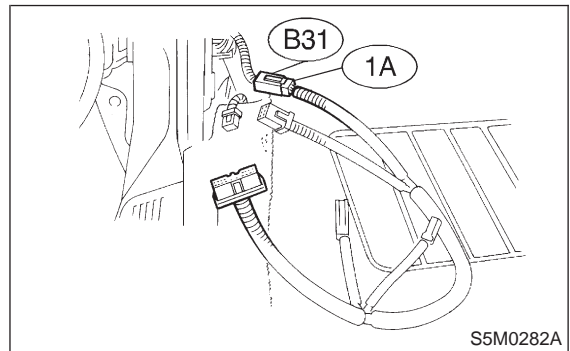

- 2) Connect battery ground cable and turn ignition switch "ON", (engine off) and connect connectors (3A) and (4A).

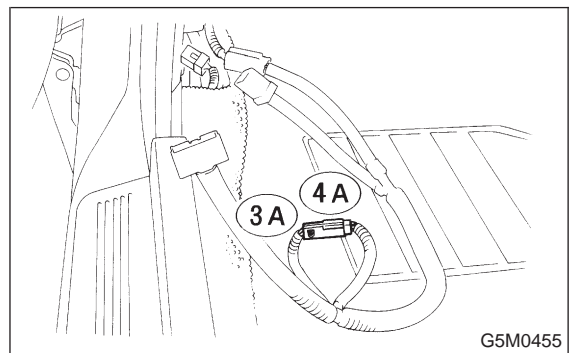

- CHECK** : *Does the airbag warning light come off?*
- YES** : Go to step **5M4**.
- NO** : Go to step **5M3**.

5M3 : INSPECTION OF BODY HARNESS

Check body harness.

NOTE:

After problem has been eliminated, disconnect connectors (3A) and (4A).

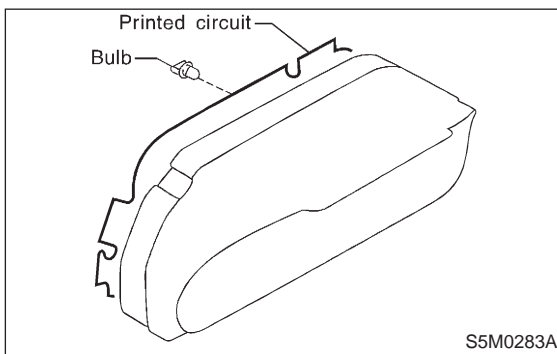

CHECK : *Is there anything unusual to body harness?*

YES : Repair body harness.

NO : Replace airbag warning light bulb <Ref. to 6-2 [W8B0].> or combination meter printed circuit.

5M4 : CHECK POOR CONTACT IN CONNECTOR (AB6).

Check connector (AB6) connected to airbag control module. <Ref. to 5-5 [W5A0].>

CHECK : *Is there poor contact in connector (AB6)?*

YES : Repair poor contact in connector (AB6).

NO : Go to step **5M5**.

5M5 : INSPECTION OF AIRBAG MAIN HARNESS

1) Turn ignition switch "OFF", disconnect battery ground cable and then wait at least 20 seconds, and re-connect connectors (AB1) and (B31).

2) Remove instrument panel lower cover and disconnect (AB3) with (AB8), then disconnect connector (AB6) from airbag control module, <Ref. to 5-5 [W5A0].> and connect it to test harness I connector (1I).

3) Connect battery ground cable and turn ignition switch "ON", (engine off) and connect connectors (4I) and (5I).

NOTE:

After problem has been eliminated, disconnect connectors (4I) and (5I).

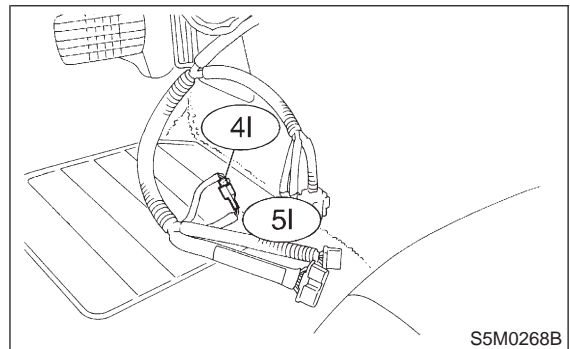

CHECK : *Does the airbag warning light come on?*

YES : Go to step **5M6**.

NO : Replace airbag main harness. <Ref. to 5-5 [W4A0].>

5-5 [T5M6]

SUPPLEMENTAL RESTRAINT SYSTEM

5. Diagnostics Chart with Trouble Code

5M6 : GROUNDING CIRCUIT INSPECTION

- 1) Turn ignition switch "OFF", disconnect battery ground cable and then wait at least 20 seconds.
- 2) Disconnect connector (AB1) from body harness connector (B31), and connect connector (B31) to test harness A connector (1A).
- 3) Measure resistance between connector (5A) terminal and chassis ground.

Connector & terminal

(5A) No. 17 (+) — Chassis ground (-):

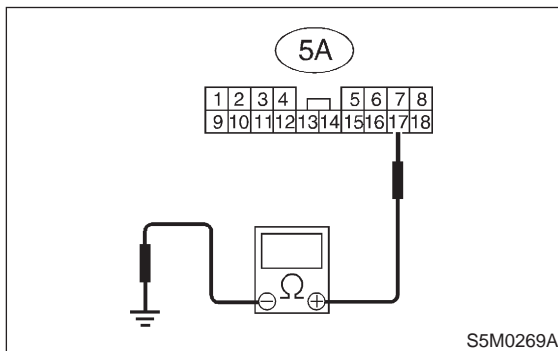

- CHECK** : Is resistance less than 10 Ω?
- YES** : Go to step 5M7.
- NO** : Repair body grounding circuit.

5M7 : GROUNDING CIRCUIT INSPECTION

Measure resistance between connector (5A) terminal and chassis ground.

Connector & terminal

(5A) No. 18 (+) — Chassis ground (-):

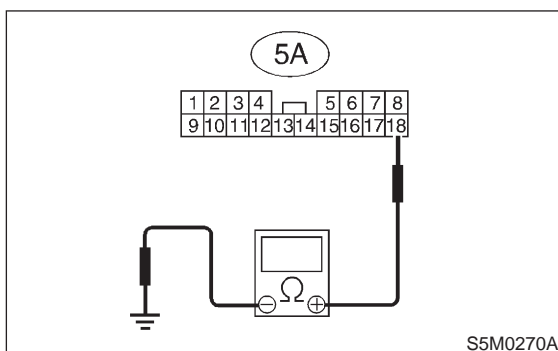

- CHECK** : Is resistance less than 10 Ω?
- YES** : Go to step 5M8.
- NO** : Repair body grounding circuit.

5M8 : INSPECTION OF AIRBAG MAIN HARNESS

- 1) Connect connectors (AB1) and (B31). Disconnect connector (AB6) from airbag control module <Ref. to 5-5 [W5A0].>, and connect it to test harness I connector (1I).
- 2) Measure resistance between each test harness I connector (2I) terminal and chassis ground.

Connector & terminal

(2I) No. 9 (+) — Chassis ground (-):

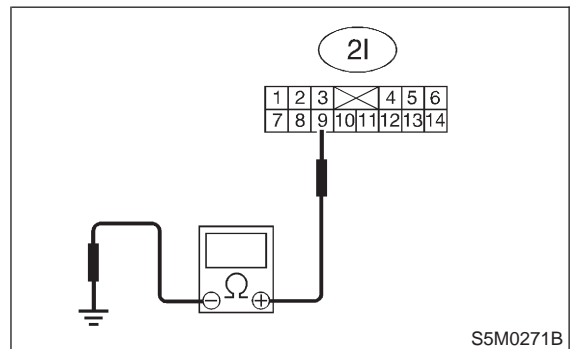

- CHECK** : Is resistance less than 10 Ω?
- YES** : Go to step 5M9.
- NO** : Replace airbag main harness. <Ref. to 5-5 [W4A0].>

5M9 : INSPECTION OF AIRBAG MAIN HARNESS

Measure resistance between each test harness I connector (2I) terminal and chassis ground.

Connector & terminal

(2I) No. 10 (+) — Chassis ground (-):

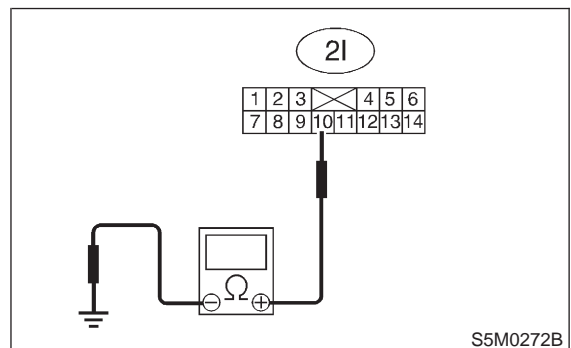

- CHECK** : Is resistance less than 10 Ω?
- YES** : Replace airbag control module. <Ref. to 5-5 [W5A0].>
- NO** : Replace airbag main harness. <Ref. to 5-5 [W4A0].>

N: AIRBAG WARNING LIGHT REMAINS OFF.

DIAGNOSIS:

- Fuse No. 18 (in joint box) is blown.
- Body harness circuit is open.
- Airbag warning light is faulty.
- Airbag main harness is faulty.
- Airbag control module is faulty.

CAUTION:

Before performing diagnostics on airbag system, turn ignition switch "OFF", disconnect battery ground terminal, and then wait at least 20 seconds.

5N1 : FUSE NO. 18 (IN JOINT BOX) INSPECTION

Remove and visually check fuse No. 5 (In joint box).

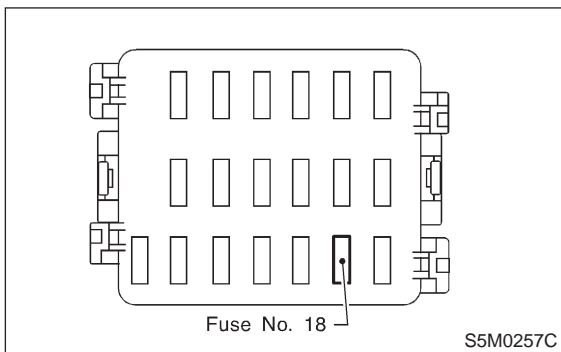

- CHECK** : *Is fuse No. 18 blown?*
- YES** : Replace fuse No. 18. If fuse No. 18 blows again, Go to step 5N2.
- NO** : Go to step 5N2.

5N2 : BODY HARNESS INSPECTION

Turn ignition switch "ON" (engine off) to make sure other warning lights (in combination meter) illuminate.

- CHECK** : *Do all the warning lights (in combination meter) except airbag warning light come on?*
- YES** : Go to step 5N3.
- NO** : Repair body harness.

5N3 : AIRBAG WARNING LIGHT MODULE (IN COMBINATION METER) INSPECTION

- 1) Turn ignition switch "OFF", disconnect battery ground cable and then wait at least 20 seconds.
- 2) Disconnect body harness connector (B31) from connector (AB1).

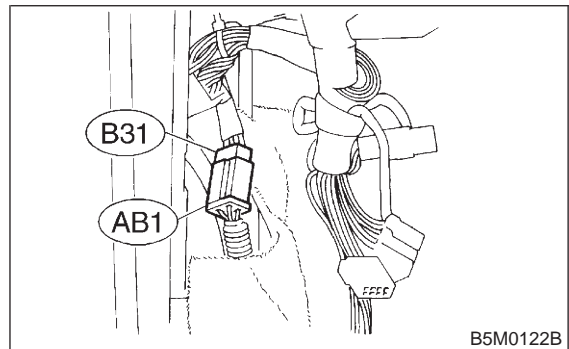

- 3) Connect battery ground cable and turn ignition switch "ON" (engine off) to make sure airbag warning light illuminates.

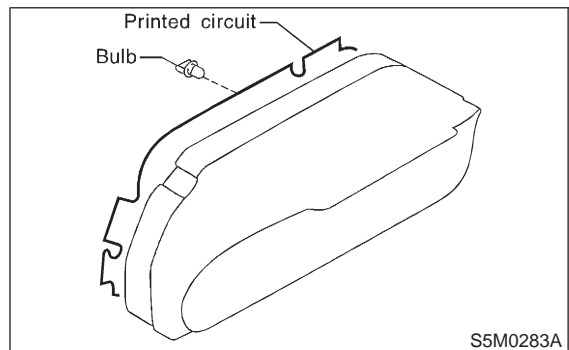

- CHECK** : *Does the airbag warning light come on?*
- YES** : Go to step 5N4.
- NO** : Replace airbag warning light bulb <Ref. to 6-2 [W8B0].> or combination meter printed circuit.

5N4 : AIRBAG MAIN HARNESS INSPECTION

- 1) Turn ignition switch "OFF", disconnect battery ground cable and then wait at least 20 seconds.
- 2) Connect body harness connector (B31) and connector (AB1).
- 3) Disconnect connectors (AB3) and (AB8) below steering column. <Ref. to 5-5 [M2F2].>

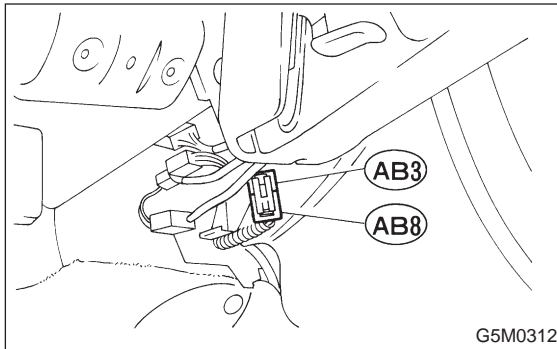

- 4) Disconnect connector (AB6) from airbag control module. <Ref. to 5-5 [W5A0].>
- 5) Connect battery ground cable and turn ignition switch "ON" to make sure airbag warning light illuminates.

- CHECK** : **Does the airbag warning light come on?**
- YES** : Replace airbag control module. <Ref. to 5-5 [W5A0].>
- NO** : Replace airbag main harness. <Ref. to 5-5 [W4A0].>

O: WARNING LIGHT INDICATES TROUBLE CODE, THEN NORMAL CODE. (FLASHING TROUBLE CODE.)

DIAGNOSIS:

Airbag system component parts are faulty.

CAUTION:

Before performing diagnostics on airbag system, turn ignition switch “OFF”, disconnect battery ground cable, and then wait at least 20 seconds.

501 : AIRBAG COMPONENT PARTS APPEARANCE INSPECTION

- 1) Conduct on-board diagnostic and call up trouble codes stored in memory. <Ref. to 5-5 [T4B0].>
- 2) Select trouble code required to check airbag component parts from those listed in table and reproduce symptom.

Trouble codes	Check parts	Index. No.
5	<ul style="list-style-type: none"> ● Airbag module (Driver) ● Roll connector ● Airbag main harness ● Airbag control module 	<Ref. to 5-5 [W3A1].> <Ref. to 5-5 [W600].> <Ref. to 5-5 [W4A0].> <Ref. to 5-5 [W5A0].>
11	<ul style="list-style-type: none"> ● Roll connector ● Airbag module (Driver) ● Airbag main harness ● Airbag control module 	<Ref. to 5-5 [W600].> <Ref. to 5-5 [W3A1].> <Ref. to 5-5 [W4A0].> <Ref. to 5-5 [W5A0].>
12	<ul style="list-style-type: none"> ● Airbag module (Passenger) ● Airbag main harness ● Airbag control module 	<Ref. to 5-5 [W3A2].> <Ref. to 5-5 [W4A0].> <Ref. to 5-5 [W500].>
15	<ul style="list-style-type: none"> ● Airbag module (Driver) ● Roll connector ● Airbag main harness ● Airbag control module 	<Ref. to 5-5 [W3A1].> <Ref. to 5-5 [W600].> <Ref. to 5-5 [W4A0].> <Ref. to 5-5 [W5A0].>
16	<ul style="list-style-type: none"> ● Airbag main harness ● Airbag module (Passenger) ● Airbag control module 	<Ref. to 5-5 [W4A0].> <Ref. to 5-5 [W3A2].> <Ref. to 5-5 [W5A0].>
21	Airbag control module	<Ref. to 5-5 [W5A0].>
22	Airbag control module	<Ref. to 5-5 [W5A0].>
25	<ul style="list-style-type: none"> ● Fuse No. 6 ● Airbag main harness ● Airbag control module ● Body harness 	<Ref. to 5-5 [T5J5].> <Ref. to 5-5 [W4A0].> <Ref. to 5-5 [W5A0].> <Ref. to 5-5 [W4A0].>
31	<ul style="list-style-type: none"> ● Airbag main harness ● Front sub sensor and front sub sensor harness (RH) 	<Ref. to 5-5 [W4A0].> <Ref. to 5-5 [W7A0].>
32	<ul style="list-style-type: none"> ● Airbag main harness ● Front sub sensor and front sub sensor harness (LH) 	<Ref. to 5-5 [W4A0].> <Ref. to 5-5 [W7A0].>

3) Conduct appearance inspection on parts selected.

NOTE:

Also check connector terminals, wiring harness, case, etc. for damage.

CHECK : *Is there anything unusual about the appearance of airbag component parts?*

YES : Replace faulty airbag component parts.

NO : Go to step **502**.

502 : AIRBAG COMPONENT PARTS VIBRATION INSPECTION

- 1) Gently shake check parts (to determine faults).
- 2) To check airbag module or roll connector, turn and tilt steering wheel.

CAUTION:

Do not shake or vibrate airbag control module.

CHECK : *Does the component malfunction again when shaking?*

YES : Replace faulty airbag component parts.

NO : Go to step 503.

503 : SHOWERING INSPECTION TO BODY

Spray water on vehicle body.

CAUTION:

Do not directly spray water on airbag components.

NOTE:

Also check wiring harnesses as water may leak along them and get airbag component parts wet.

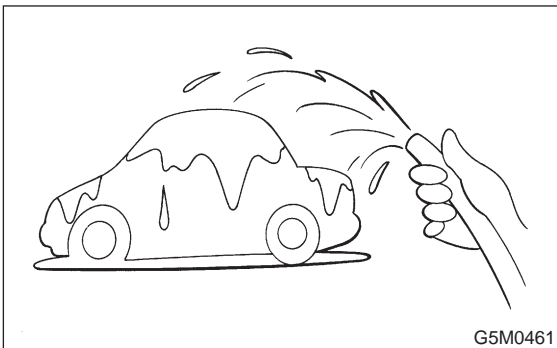

CHECK : *Does water leak into the passenger compartment when showering vehicle?*

YES : Replace faulty airbag component parts.

NO : Perform clear memory. <Ref. to 5-5 [T4C0].>

P: WARNING LIGHT INDICATES TROUBLE CODE, THEN NORMAL CODE. (FLASHING NORMAL CODE.)**DIAGNOSIS:**

- Airbag connector is faulty.
- Fuse No. 11 (in joint box) is blown.
- Airbag main harness is faulty.
- Airbag control module is faulty.
- Body harness is faulty.

CAUTION:

Before performing diagnostics on airbag system, turn ignition switch "OFF", disconnect battery ground cable, and then wait at least 20 seconds.

5P1 : AIRBAG CONNECTOR APPEARANCE INSPECTION

Conduct appearance inspection on airbag connectors (AB2) through (AB8). <Ref. to 5-5 [T100].>

NOTE:

Check terminals, case and wiring harnesses for damage.

CHECK : *Is there anything unusual about the appearance of connectors (AB2) through (AB8)?*

YES : Replace faulty airbag component parts.

NO : Go to step 5P2.

5P2 : AIRBAG CONNECTOR VIBRATION INSPECTION

Conduct vibration inspection on airbag connectors (AB2) through (AB8). <Ref. to 5-5 [T100].>

NOTE:

Gently shake each airbag connector.

CHECK : *Do the connectors (AB2) through (AB8) malfunction again when shaking?*

YES : Replace faulty airbag component parts.

NO : Go to step 5P3.

5P3 : SHOWERING INSPECTION TO BODY

Spray water on vehicle body.

CAUTION:

Do not directly spray water on airbag components.

NOTE:

If leaks are noted, also check wiring harnesses as water may leak along them and wet airbag connectors.



- CHECK** : *Does water leak into the passenger compartment when showering vehicle?*
- YES** : Replace faulty airbag component parts.
- NO** : Go to step **5P4**.

5P4 : FUSE NO. 11 (IN JOINT BOX), AIR-BAG MAIN HARNESS, AIRBAG CONTROL MODULE, BODY HARNESS APPEARANCE INSPECTION

Conduct appearance inspection on fuse No. 11 <Ref. to 5-5 [T5I5].>, airbag main harness <Ref. to 5-5 [W4A0].>, airbag control module <Ref. to 5-5 [W5A0].> and body harness.

NOTE:

Also check connectors, terminals, wiring harness and case for damage.

- CHECK** : *Is there anything unusual about the appearance of fuse No. 11, airbag main harness, airbag control module or body harness?*
- YES** : Replace faulty airbag component parts.
- NO** : Go to step **5P5**.

5P5 : FUSE NO. 11 (IN JOINT BOX), AIR-BAG MAIN HARNESS, BODY HARNESS VIBRATION INSPECTION

Conduct vibration inspection on fuse No. 11, airbag main harness and body harness.

CAUTION:

Do not shake or vibrate airbag control module.

NOTE:

Gently shake each part.

- CHECK** : *Do fuse No. 11, airbag main harness or body harness malfunction again when shaking?*
- YES** : Replace faulty airbag component parts.
- NO** : Go to step **5P6**.

5P6 : SHOWERING INSPECTION TO BODY

Spray water on vehicle body.

CAUTION:

Do not directly spray water on each part.

NOTE:

If leaks are noted, check wiring harnesses as water may leak along them and get parts wet.

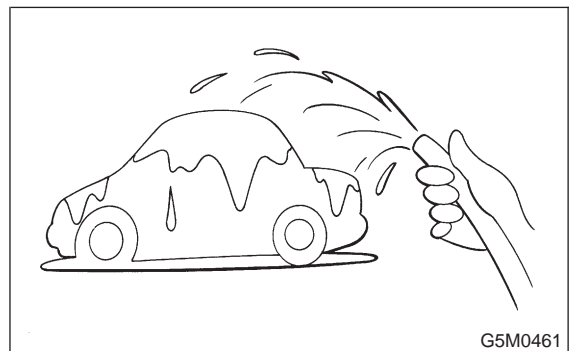

- CHECK** : *Does water leak into the passenger compartment when showering vehicle?*
- YES** : Replace faulty airbag component parts.
- NO** : Go to step **5P7**.

5-5 [T5P7]

SUPPLEMENTAL RESTRAINT SYSTEM

5. Diagnostics Chart with Trouble Code

5P7 : WARNING LIGHT ILLUMINATION CHECK

Turn ignition switch "ON" (engine off) and observe airbag warning light.

- CHECK** : ***Does the airbag warning light come on for about 7 seconds, then go out and stay out?***
- YES** : Perform clear memory. <Ref. to 5-5 [T4C0].>
- NO** : Go to "DIAGNOSTICS PROCEDURE". <Ref. to 5-5 [T4D0].>