

3. Basic Checks

A: DISCONNECTING CONNECTORS

- Always hold the connector itself.

CAUTION:

Don't pull the harness.

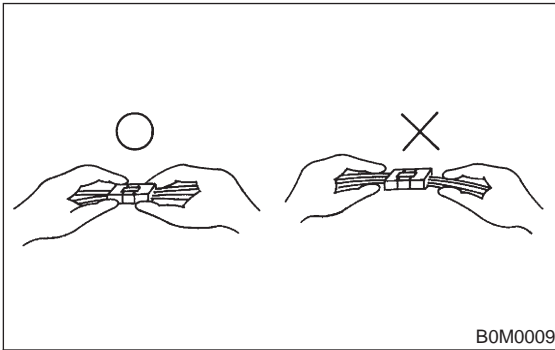

- Inspect a connector by pushing it all the way in. If the connector is equipped with a locking device, push it in until a clicking sound is heard.

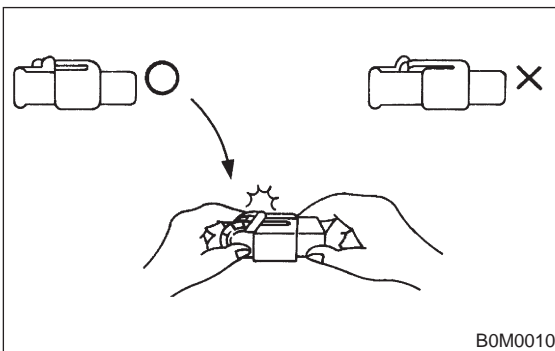

- To disconnect a locking connector, first release the lock, then pull the connector off.
<Unlock by pulling the locking tab.>

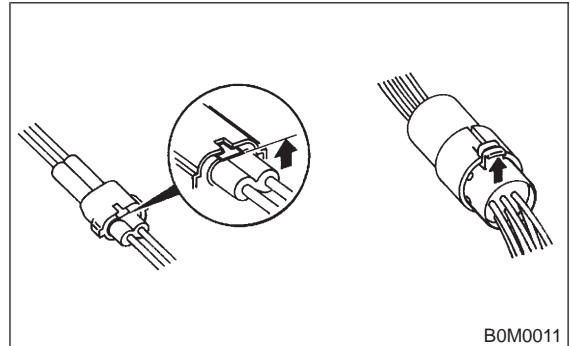

<Unlock by pushing the locking tab.>

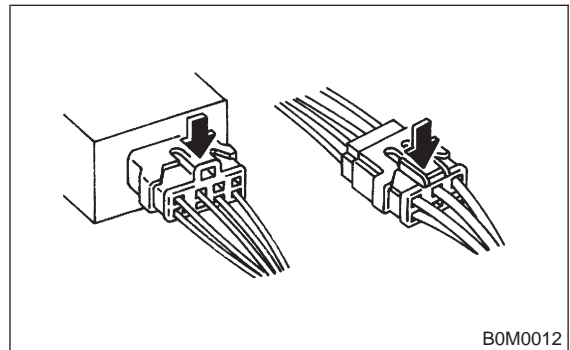

B: INSERTING A PROBE

CAUTION:

Poor contact has been identified as a primary cause of this problem. To measure the voltage and/or resistance of individual sensors or all electrical control modules at the harness side connector, use a tapered pin with a diameter of less than 0.64 mm (0.025 in). Do not insert the pin more than 5 mm (0.20 in) into the part.

- Generally, probes are inserted into connectors from the rear side (wire side).
- When removing the shock protector take care not to deform it; this also applies to waterproof connectors, which cannot be tested from the wire side.

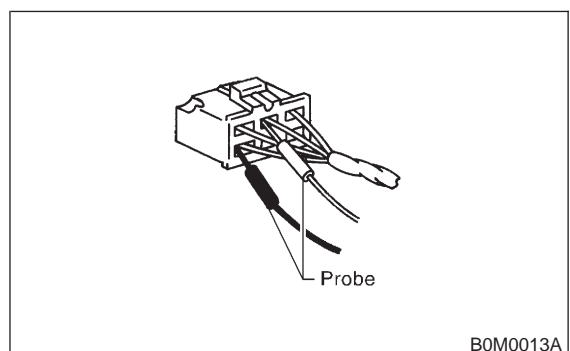

- Connectors equipped with shock protectors must be checked with a mini probe (thin), or it will be necessary to remove the shock protector.

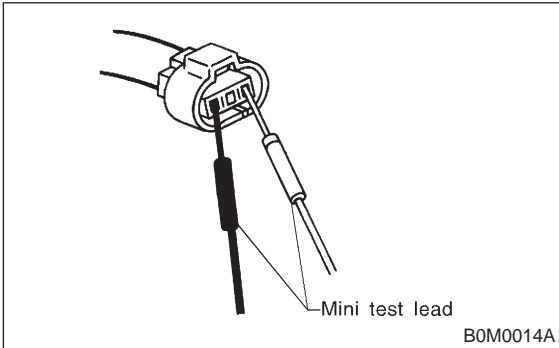

- When the connector has a back plate, remove the plate after removing the projection of the plate first. (Be careful not to use excessive force, since the terminals might brake off.)

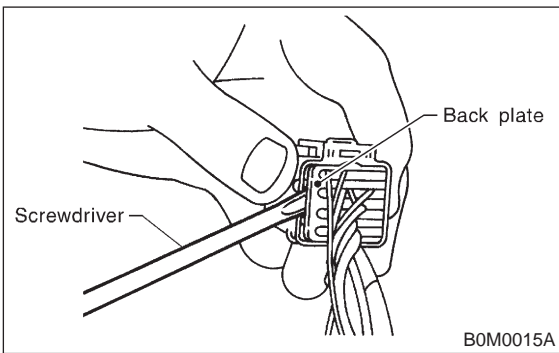

C: CHECKING FOR POOR CONTACT ON PLUG-IN CONNECTORS

1. POOR CONTACT

Poor contact is frequently caused by corroded terminals, dirt, foreign substances, weak contact points between male and female connectors, etc. Quite often a plug with poor contact will work perfectly again after it has been pulled off and reconnected. If harness and connector checks do not reveal any defect, it can be assumed that an intermittent contact in a connector is the source of trouble.

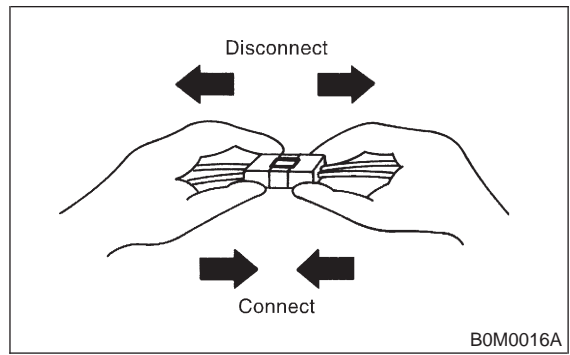

2. VISUAL INSPECTION

- 1) Disconnect the two connector halves.
- 2) Check the connector pins for signs of corrosion or foreign material.
- 3) Check the connector for loose and damaged terminals, and make sure they are set correctly in the connector.

NOTE:

When the harness is pulled lightly, the terminals should not come out.

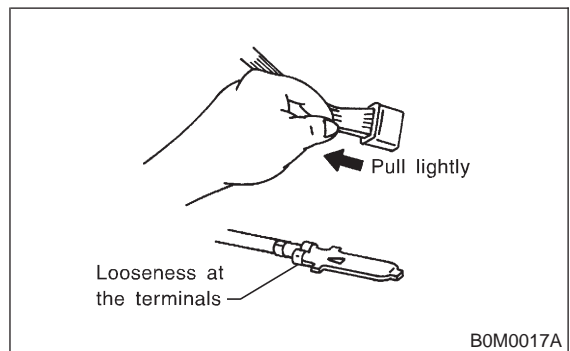

FOREWORD [T4A1]

4. Diagnosis and Checking Procedure Using Instruments

4) Insert the male pin of the connector into the female pin, then pull it out.

NOTE:

If one of the pins allows to pull out easily, it is a likely source of a malfunction.

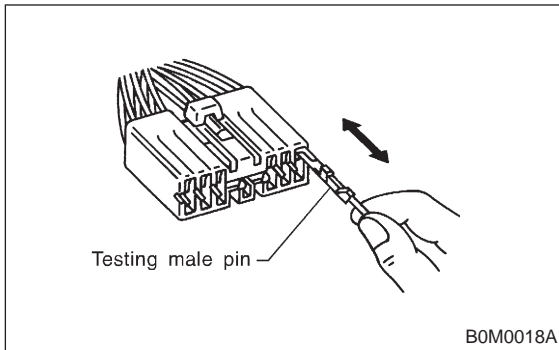

5) Shake lightly the connector and the harness, and check for sudden changes in voltage or resistance.

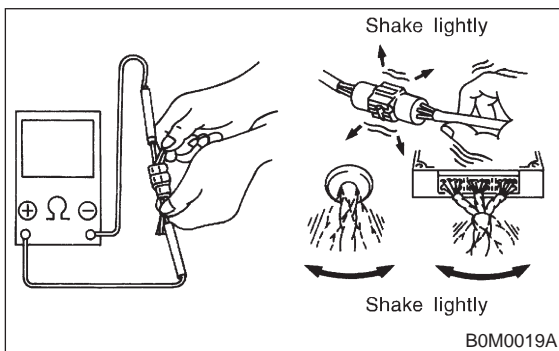

FOREWORD

4. Diagnosis and Checking Procedure Using Instruments

A: USING A CIRCUIT TESTER

CAUTION:

Poor contact has been identified as a primary cause of this problem. To measure the voltage and/or resistance of individual sensors or all electrical control modules at the harness side connector, use a tapered pin with a diameter of less than 0.64 mm (0.025 in). Do not insert the pin more than 5 mm (0.20 in) into the part.

1. VOLTAGE CHECK (range set to DC V)

Connect the positive probe to the terminal to be tested, and the negative probe to body ground. (or the ground terminal of the ECM)

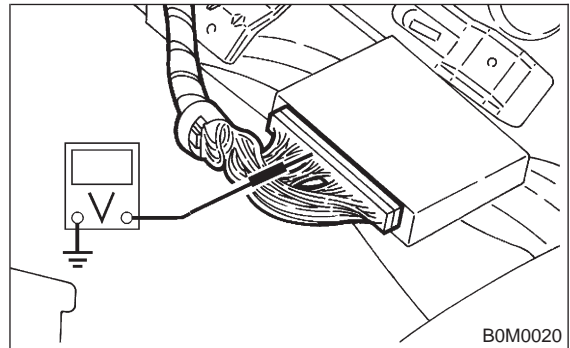

2. CHECKING THE CONNECTION (range set to Ω)

Measure the resistance and check for open or shorted wire in the harness or the connector.

NOTE:

This check must be carried out with both connectors disconnected.

(This avoids by-passing the connection through other circuits.)

