

1. Oil Pump

A: REMOVAL

1) Disconnect battery ground cable.

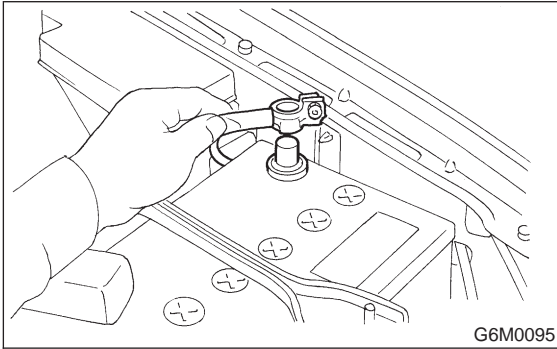

2) Lift-up the vehicle.

3) Remove under cover.

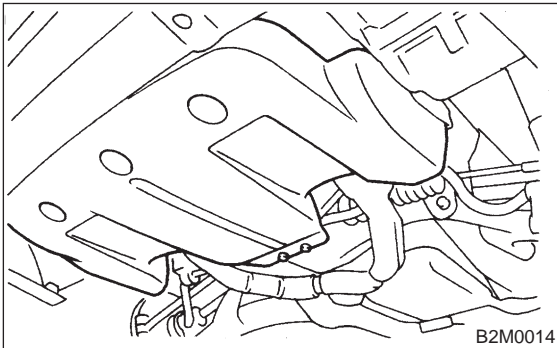

4) Drain coolant. <Ref. to 2-5 [W1A0].>

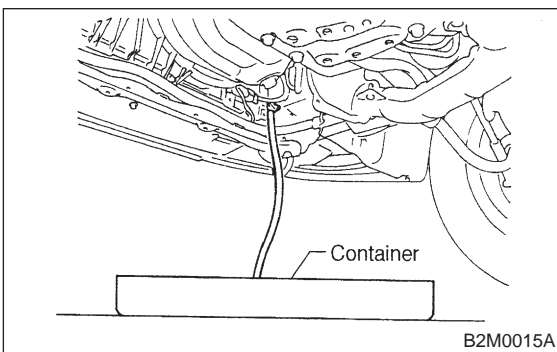

5) Disconnect connectors from radiator main fan (A) and sub fan (B) motors.

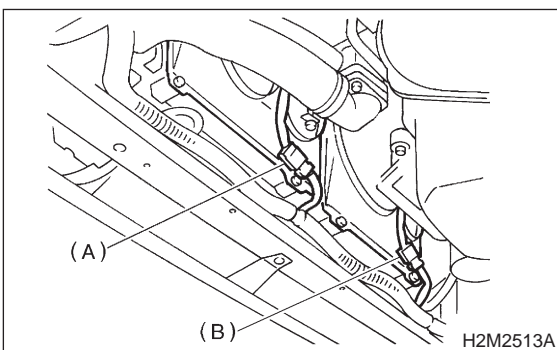

6) Lower the vehicle.

7) Remove radiator main fan and sub fan assemblies. <Ref. to 2-5 [W7A0].>

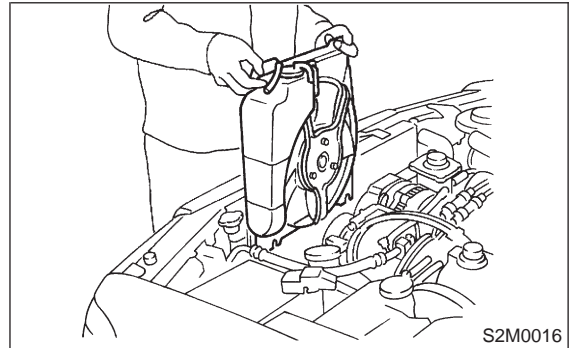

8) Remove crankshaft position sensor.

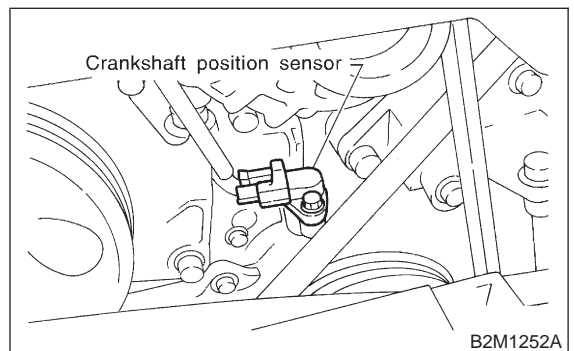

9) Remove camshaft position sensor.

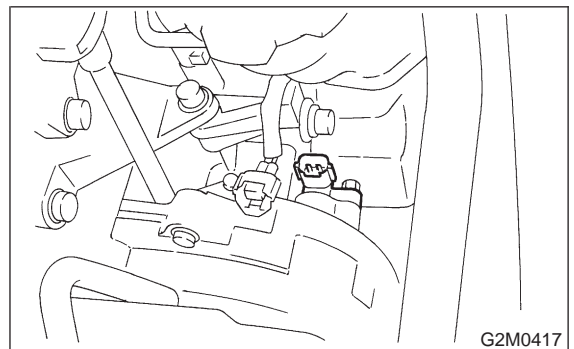

10) Remove V-belts. <Ref. to 1-5 [G200].>

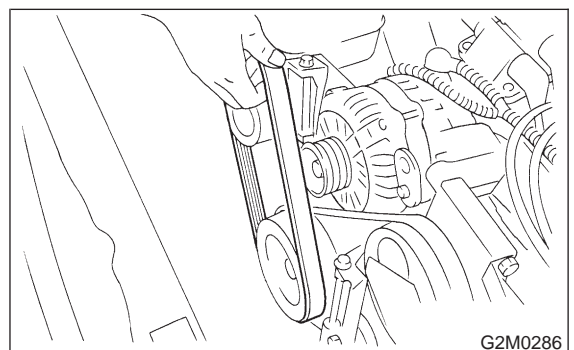

11) Remove rear side V-belt tensioner.

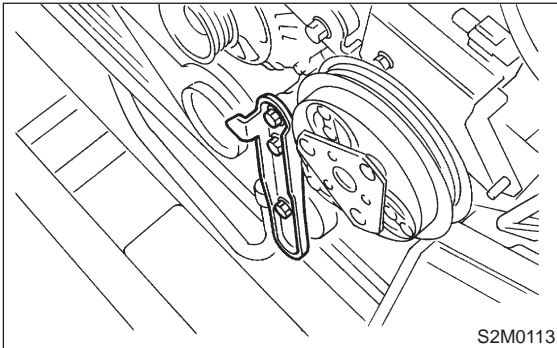

12) Remove crankshaft pulley by using ST.
ST 49997700 CRANKSHAFT PULLEY
WRENCH

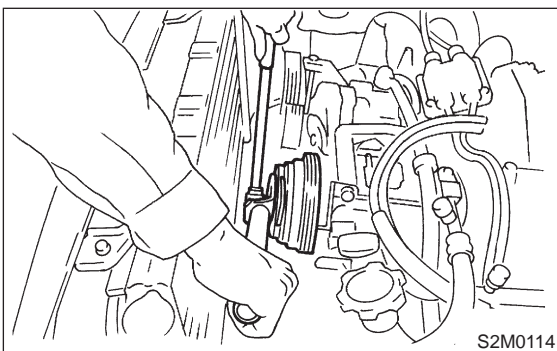

13) Remove timing belt.
<Ref. to 2-3 [W2A0].>

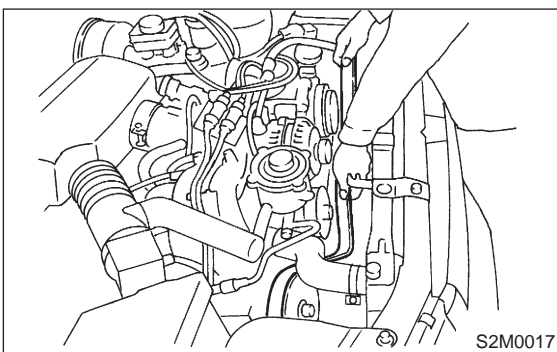

14) Remove water pump. <Ref. to 2-5 [W2A0].>

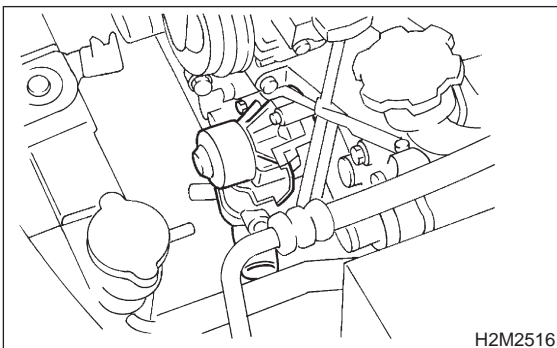

15) Remove timing belt guide. (MT vehicles only)

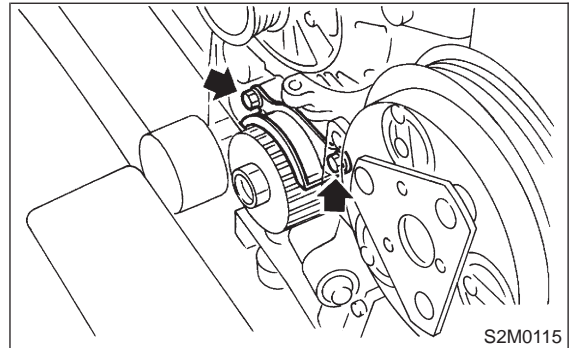

16) Remove crankshaft sprocket.

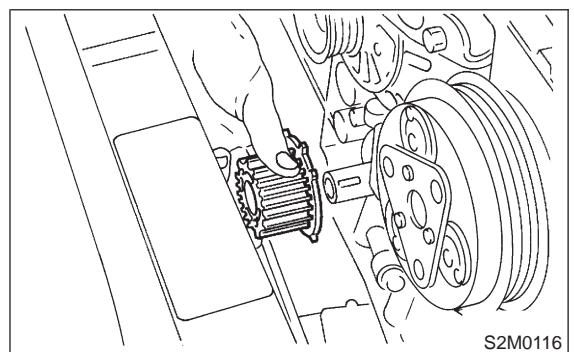

17) Remove bolts which install oil pump onto cylinder block.

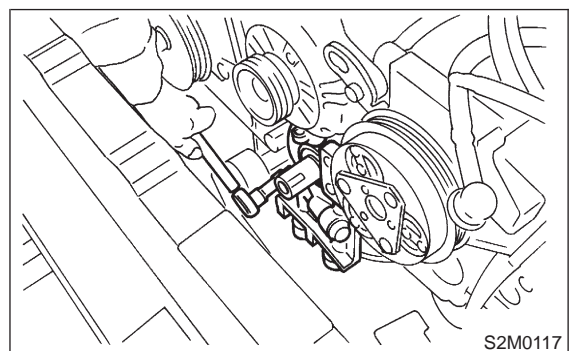

18) Remove oil pump by using flat bladed screwdriver.

CAUTION:
Be careful not to scratch mating surfaces of cylinder block and oil pump.

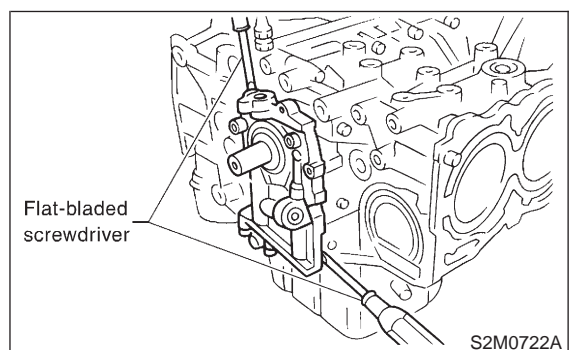

B: DISASSEMBLY

Remove screws which secure oil pump cover and disassemble oil pump.

Inscribe alignment marks on inner and outer rotors so that they can be replaced in their original positions during reassembly.

CAUTION:

Before removing relief valve, loosen plug when removing oil pump from cylinder block.

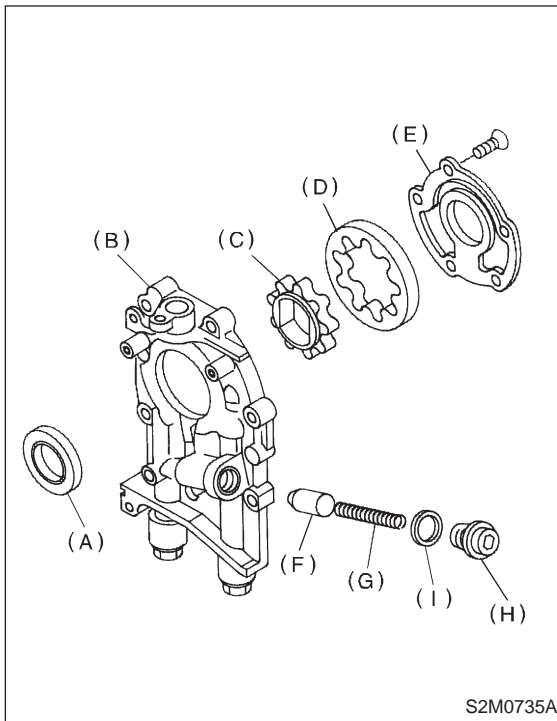

- (A) Oil seal
- (B) Pump case
- (C) Inner rotor
- (D) Outer rotor
- (E) Pump cover
- (F) Relief valve
- (G) Relief spring
- (H) Plug
- (I) Washer

C: INSPECTION

1. TIP CLEARANCE

Measure the tip clearance of rotors. If the clearance exceeds the limit, replace rotors as a matched set.

Tip clearance:

Standard

0.04 — 0.14 mm (0.0016 — 0.0055 in)

Limit

0.18 mm (0.0071 in)

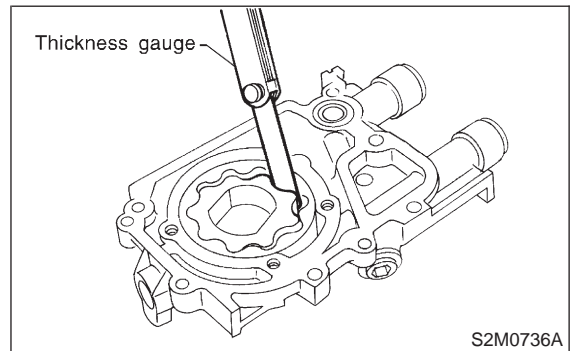

2. CASE CLEARANCE

Measure the clearance between the outer rotor and the cylinder block rotor housing. If the clearance exceeds the limit, replace the rotor.

Case clearance:

Standard

0.10 — 0.175 mm (0.0039 — 0.0069 in)

Limit

0.20 mm (0.0079 in)

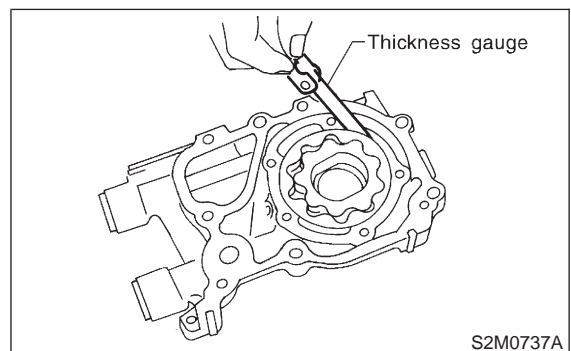

3. SIDE CLEARANCE

Measure clearance between oil pump inner rotor and pump cover. If the clearance exceeds the limit, replace rotor or pump body.

Side clearance:

Standard

0.02 — 0.07 mm (0.0008 — 0.0028 in)

Limit

0.15 mm (0.0059 in)

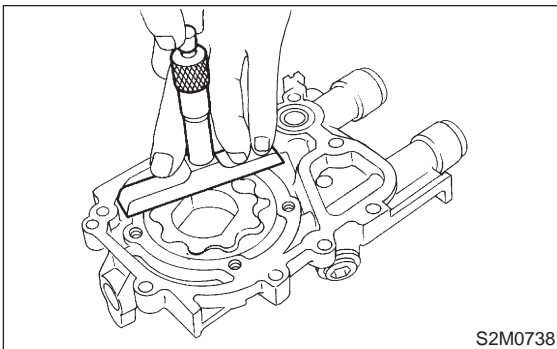

4. OIL RELIEF VALVE

Check the valve for fitting condition and damage, and the relief valve spring for damage and deterioration. Replace the parts if defective.

Relief valve spring:

Free length; 71.8 mm (2.827 in)

Installed length; 54.7 mm (2.154 in)

Load when installed; 77.08 N (7.86 kg, 17.33 lb)

5. OIL PUMP CASE

Check the oil pump case for worn shaft hole, clogged oil passage, worn rotor chamber, cracks, and other faults.

6. OIL SEAL

Check the oil seal lips for deformation, hardening, wear, etc. and replace if defective.

D: ASSEMBLY

- 1) Install front oil seal by using ST.
ST 499587100 OIL SEAL INSTALLER

CAUTION:

Use a new oil seal.

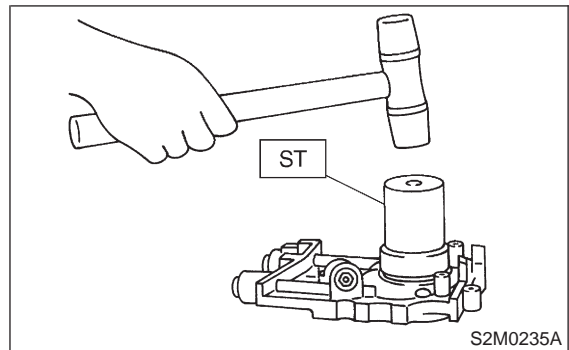

- 2) Install inner and outer rotors in their original positions.
- 3) Install oil relief valve and relief spring.
- 4) Install oil pump cover.

Tightening torque:

T1: 5 — 6 N·m (0.5 — 0.6 kg·m, 3.6 — 4.3 ft·lb)

T2: 40.7 — 47.6 N·m (4.15 — 4.85 kg·m, 30.0 — 35.1 ft·lb)

