

## 6. Fuel Meter Unit

### A: REMOVAL

NOTE:

Fuel meter unit is built in fuel pump assembly.

- 1) Release fuel pressure. <Ref. to 2-8 [W1B0].>
- 2) Open fuel flap lid, and remove fuel filler cap.

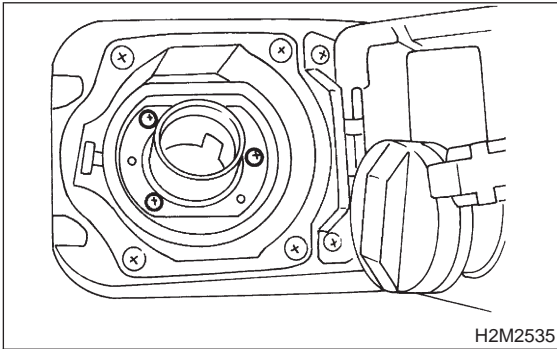

- 3) Disconnect battery ground cable.

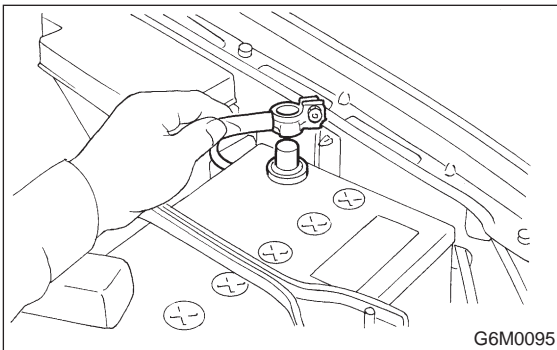

- 4) Disconnect connector from fuel pump.

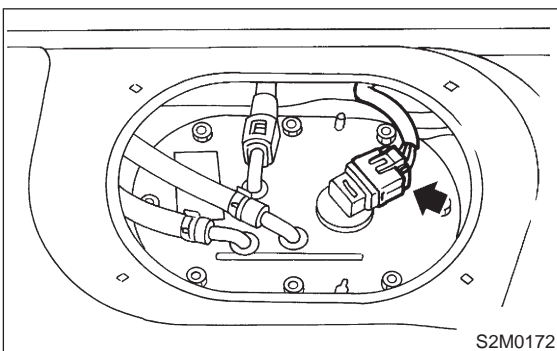

- 5) Move clips, and then disconnect fuel return hose (B) and jet pump hose (C).

- 6) Disconnect quick connector, and then disconnect fuel delivery hose (A). <Ref. to 2-8 [W7A0].>

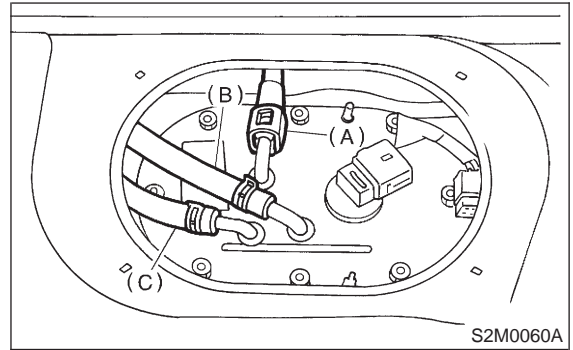

- 7) Remove nuts which install fuel pump assembly onto fuel tank.

- 8) Take off fuel pump assembly.

- 9) Disconnect connector from fuel pump bracket.

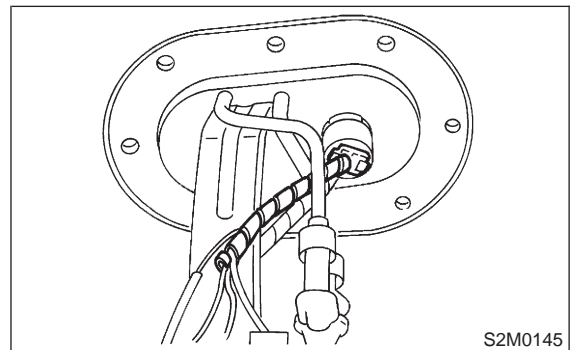

- 10) Remove bolt which installs fuel meter unit on mounting bracket.

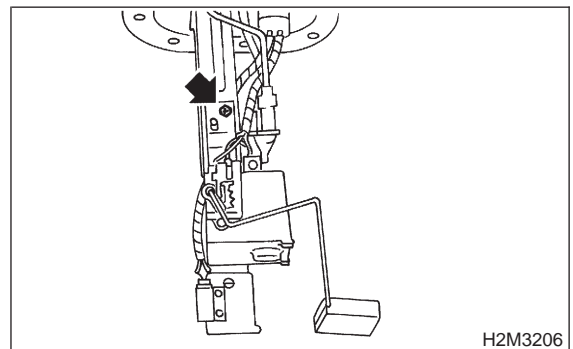

**B: INSTALLATION**

Installation is in the reverse order of removal. Do the following:

- (1) Install the fuel meter unit on mounting bracket.

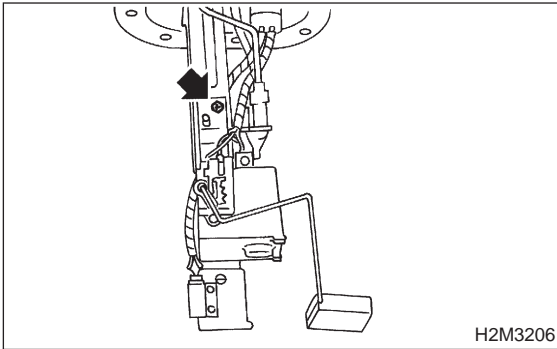

- (2) Always use new gaskets.
- (3) Ensure sealing portion is free from fuel or foreign particles before installation.
- (4) Tighten nuts in alphabetical sequence shown in Figure to specified torque.

**Tightening torque:**

**$4.4 \pm 1.5 \text{ N}\cdot\text{m}$  ( $0.45 \pm 0.15 \text{ kg}\cdot\text{m}$ ,  $3.3 \pm 1.1 \text{ ft}\cdot\text{lb}$ )**

