

2. How to Use this Manual

● This Service Manual is divided into four volumes by section so that it can be used with ease at work. Refer to the Table of Contents, select and use the necessary section.

- GENERAL INFORMATION SECTION
- REPAIR SECTION
- DIAGNOSTICS SECTION
- WIRING DIAGRAM SECTION

● Each chapter in the manual is basically made of the following four types of areas.

S	SPECIFICATIONS AND SERVICE DATA
C	COMPONENT PARTS
W (X (Y	SERVICE PROCEDURE SERVICE PROCEDURE) SERVICE PROCEDURE)
K	DIAGNOSTICS

● The description of each area is provided with four types of titles different in size as shown below. The Title No. or Symbol prefixes each title in order that the construction of the article and the flow of explanation can be easily understood.

[Example of each title]

● Area title:	W SERVICE PROCEDURE (one of the four types of areas)
● Large title (Heading):	1. Oil Pump (to denote the main item of explanation)
● Medium title (Section):	A: REMOVAL (to denote the type of work in principle)
● Small title (Sub-section):	1. INNER ROTATOR (to denote a derivative item of explanation)

- The Title Index No. is indicated on the top left (or right) side of the page as the book is opened. This is useful for retrieving the necessary portion.

(Example of usage)

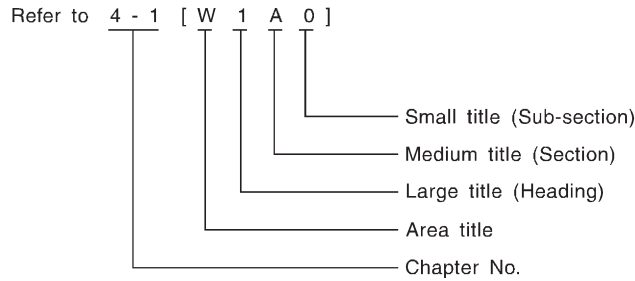

Example of title placement
 Title index No.

SERVICE PROCEDURE

[W1A2] **4-1**
1. On-car Service

1. On-car Service
A: WHEEL ALIGNMENT
 Check adjust and/or measure wheel alignment in accordance with procedures indicated below:

1. WHEEL ARCH HEIGHT

↓

2. CAMBER & CASTER

↓

3. REAR TOE-IN

↓

4. THRUST ANGLE

↓

5. FRONT TOE-IN

↓

6. STEERING ANGLE

M4A0056



Front

Wheel arch height

1. WHEEL ARCH HEIGHT

- 1) Inflate tire pressure to specifications.
- 2) Set vehicle under "curb weight" conditions. (Empty luggage compartment, install spare tire, jack, service tools, and top up fuel tank).
- 3) Set steering wheel in a wheel-forward position.
- 4) Suspend thread from wheel arch to determine a point directly above center of spindle.
- 5) Measure distance between measuring point and center of spindle.

- In this manual, the following symbols are used.

*	Selective part
★	Replacement part
	Should be lubricated with oil.
	Should be lubricated with grease.
	Sealing point
T	Tightening torque

- WARNING, CAUTION, NOTE**

- WARNING:** Indicates the item which must be observed precisely during performance of maintenance services in order to avoid injury to the mechanics and other persons.
- CAUTION:** Indicates the item which must be followed precisely during performance of maintenance services so as to avoid damage and breakage to the vehicle and its parts and components.
- NOTE:** Indicates the hints, knacks, etc. which make the maintenance job easier.

- SPECIAL TOOLS**

When any special tool is required to perform the job, it is identified by "ST" in the applicable illustration and its part number is shown in the manual.

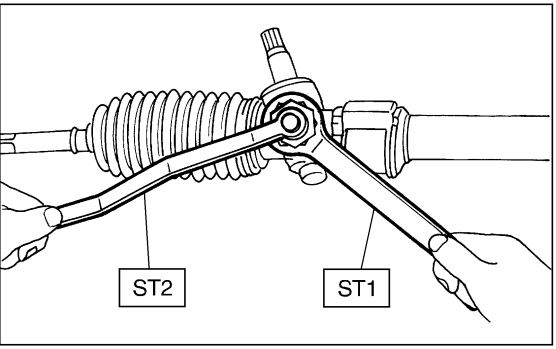

1. Procedures for adjusting backlash

- 1) Set steering wheel to the straight-ahead position.
- 2) Remove the exhaust pipe.
- 3) Loosen the lock nut with ST. ←

ST1 921650000 STEERING GEARBOX WRENCH
ST2 921550000 STEERING GEARBOX WRENCH

Description _____
(of job method)

Shows the part name

Shows the part number

Tells that two kinds of special tools are required.
When two or more kinds of special tools are required to do a job, they are identified by ST1, ST2,.....respectively.

H0M0011A