

## 14. ABS Control Module and Hydraulic Control Unit (ABSCM&H/U)

### A: REMOVAL

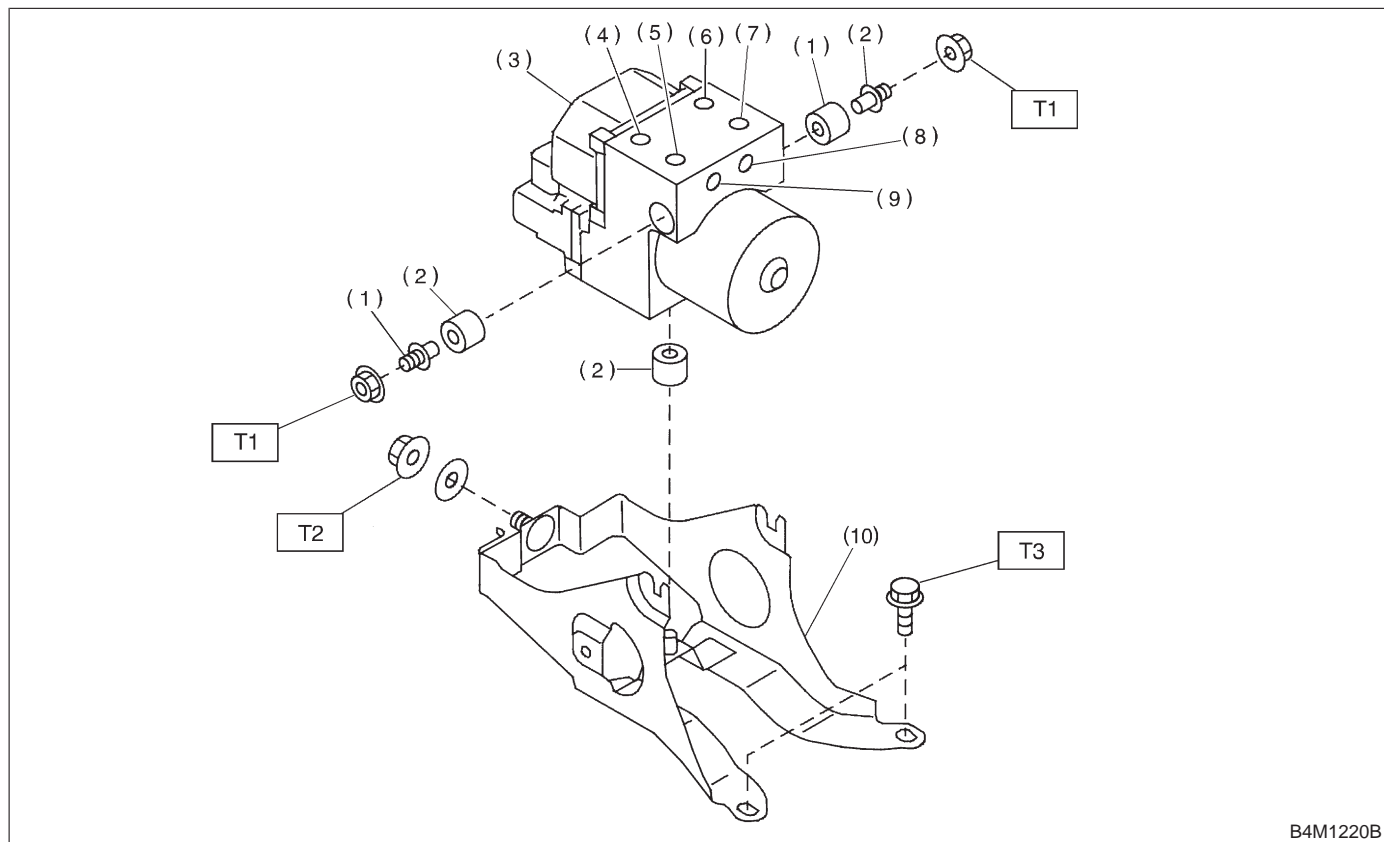

- |   |                     |
|---|---------------------|
| (1) Stud bolt                                     | (6) Front-RH outlet |
| (2) Damper  | (7) Primary inlet   |
| (3) ABS control module and hydraulic control unit | (8) Rear-LH outlet  |
| (4) Front-LH outlet                               | (9) Rear-RH outlet  |
| (5) Secondary inlet                               | (10) Bracket        |

**Tightening torque: N-m (kg-m, ft-lb)**

**T1: 18±5 (1.8±0.5, 13.0±3.6)**

**T2: 29±7 (3.0±0.7, 21.7±5.1)**

**T3: 32±10 (3.3±1.0, 24±7)**

- 1) Disconnect ground cable from battery.
- 2) Remove air intake duct from engine compartment to facilitate removal of ABSCM&H/U.
- 3) Use an air-gun to get rid of water around the ABSCM&H/U.

**CAUTION:**

The contact will be insufficient if the terminal gets wet.

- 4) Pull on the lock of the ABSCM&H/U connector to remove it.

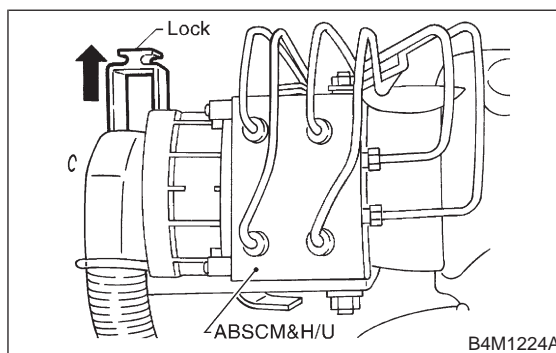

- 5) Disconnect connector from ABSCM&H/U.

**CAUTION:**

Be careful not to let water or other foreign matter contact the ABSCM&H/U terminal.

- 6) Unlock cable clip.

7) Disconnect brake pipes from ABSCM&H/U.

**CAUTION:**

Wrap brake pipes with vinyl bag to avoid spilling brake fluid on vehicle body.

8) Remove ABSCM&H/U from engine compartment.

**CAUTION:**

- ABSCM&H/U cannot be disassembled. Do not attempt to loosen bolts and nuts.
- Do not drop or bump ABSCM&H/U.
- Do not turn the ABSCM&H/U upside down or place it on its side.
- Be careful to prevent foreign particles from getting into ABSCM&H/U.
- Apply a coat of rust-preventive wax (Nippeco LT or GB) to bracket attaching bolt after tightening.
- Do not pull harness disconnecting harness connector.

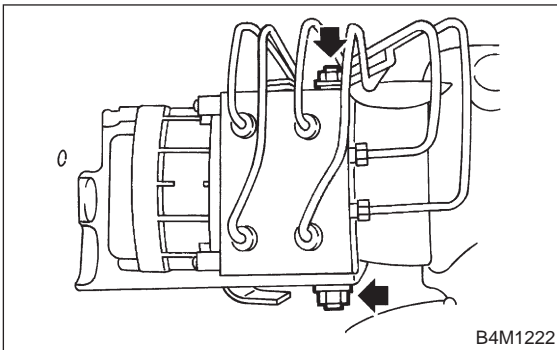

**B: INSPECTION**

- 1) Check connected and fixed condition of connector.
- 2) Check specifications of the mark with ABSCM&H/U.

Mark	Model
C5	AWD AT
C6	AWD MT

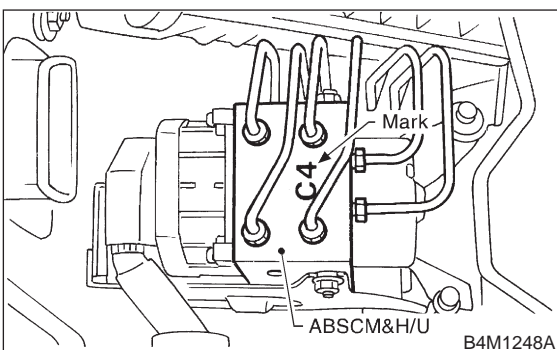

**C: CHECKING THE HYDRAULIC UNIT ABS OPERATION**

**1. CHECKING THE HYDRAULIC UNIT ABS OPERATION BY PRESSURE GAUGE**

- 1) Lift-up vehicle and remove wheels.
- 2) Disconnect the air bleeder screws from the FL and FR caliper bodies.
- 3) Connect two pressure gauges to the FL and FR caliper bodies.

**CAUTION:**

- Pressure gauges used exclusively for brake fluid must be used.
- Do not employ pressure gauge previously used for transmission since the piston seal is expanded which may lead to malfunction of the brake.

**NOTE:**

Wrap sealing tape around the pressure gauge.

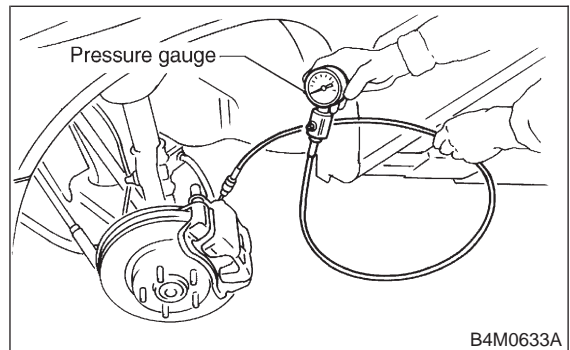

- 4) Bleed air from the pressure gauges.
- 5) Perform ABS sequence control.  
<Ref. to 4-4 [W14D0].>
- 6) When the hydraulic unit begins to work, and first the FL side performs decompression, holding, and compression, and then the FR side performs decompression, holding, and compression.
- 7) Read values indicated on the pressure gauge and check if the fluctuation of the values between decompression and compression meets the standard values. Also check if any irregular brake pedal tightness is felt.

	Front wheel	Rear wheel
Initial value	3,432 kPa (35 kg/cm <sup>2</sup> , 498 psi)	3,432 kPa (35 kg/cm <sup>2</sup> , 498 psi)
When decompressed	490 kPa (5 kg/cm <sup>2</sup> , 71 psi) or less	490 kPa (5 kg/cm <sup>2</sup> , 71 psi) or less
When compressed	3,432 kPa (35 kg/cm <sup>2</sup> , 498 psi) or more	3,432 kPa (35 kg/cm <sup>2</sup> , 498 psi) or more

8) Remove pressure gauges from FL and FR caliper bodies.

## 4-4 [W14C2]

## SERVICE PROCEDURE

### 14. ABS Control Module and Hydraulic Control Unit (ABSCM&H/U)

- 9) Remove air bleeder screws from the RL and RR caliper bodies.
- 10) Connect the air bleeder screws to the FL and FR caliper bodies.
- 11) Connect two pressure gauges to the RL and RR caliper bodies.
- 12) Bleed air from the pressure gauges and the FL and FR caliper bodies.
- 13) Perform ABS sequence control.  
<Ref. to 4-4 [W14D0].>
- 14) When the hydraulic unit begins to work, at first the RR side performs decompression, holding, and compression, and then the RL side performs decompression, holding, and compression.
- 15) Read values indicated on the pressure gauges and check if they meet the standard value.
- 16) After checking, remove the pressure gauges from caliper bodies.
- 17) Connect the air bleeder screws to RL and RR caliper bodies.
- 18) Bleed air from brake line.

### 2. CHECKING THE HYDRAULIC UNIT ABS OPERATION WITH BRAKE TESTER

- 1) In the case of AWD AT vehicles, install a spare fuse with the FWD connector in the main fuse box to simulate FWD vehicles.

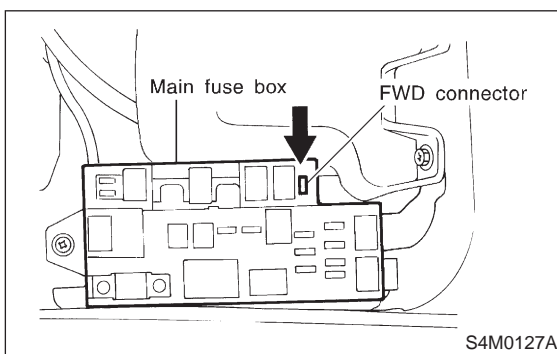

- 2) Prepare for operating ABS sequence control.  
<Ref. to 4-4 [W14D1].> or <Ref. to 4-4 [W14D2].>
- 3) Set the front wheels or rear wheels on the brake tester and set the select lever's position at "neutral".

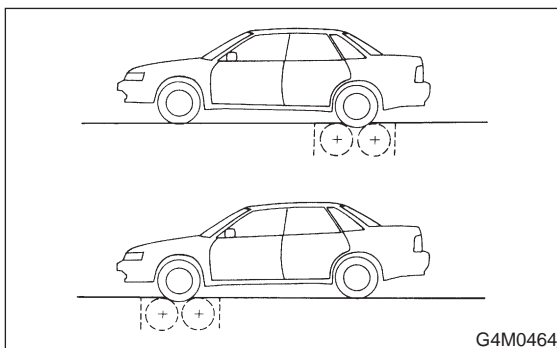

- 4) Operate the brake tester.

- 5) Perform ABS sequence control. <Ref. to 4-4 [W14D1].> or <Ref. to 4-4 [W14D2].>

- 6) Hydraulic unit begins to work; and check the following working sequence.

- (1) The FL wheel performs decompression, holding, and compression in sequence, and subsequently the FR wheel repeats the cycle.
- (2) The RR wheel performs decompression, holding, and compression in sequence, and subsequently the RL wheel repeats the cycle.

- 7) Read values indicated on the brake tester and check if the fluctuation of values, when decompressed and compressed, meet the standard values.

	Front wheel	Rear wheel
Initial value	981 N (100 kg, 221 lb)	981 N (100 kg, 221 lb)
When decompressed	490 N (50 kg, 110 lb) or less	490 N (50 kg, 110 lb) or less
When compressed	981 N (100 kg, 221 lb) or more	981 N (100 kg, 221 lb) or more

- 8) After checking, also check if any irregular brake pedal tightness is felt.

**D: ABS SEQUENCE CONTROL**

- 1) Under the ABS sequence control, after the hydraulic unit solenoid valve is driven, the operation of the hydraulic unit can be checked by means of the brake tester or pressure gauge.
- 2) ABS sequence control can be started by diagnosis connector or select monitor.

**1. OPERATIONAL GUIDELINES OF THE ABS SEQUENCE CONTROL WITH DIAGNOSIS CONNECTOR**

- 1) Connect diagnosis terminals to terminals No. 3 and No. 6 of the diagnosis connector beside driver's seat heater unit.

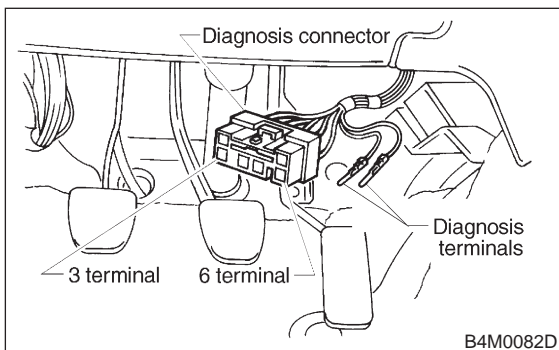

- 2) Set the speed of all wheels at 4 km/h (2 MPH) or less.
- 3) Turn ignition switch OFF.
- 4) Within 0.5 seconds after the ABS warning light goes out, depress the brake pedal and hold it immediately after ignition switch is turned to ON.

**CAUTION:**  
Do not depress the clutch pedal.

NOTE:

- When the ignition switch is set to on, the brake pedal must not be depressed.
  - Engine must not operate.
- 5) After completion of ABS sequence control, turn ignition switch OFF.

**2. OPERATIONAL GUIDELINES OF THE ABS SEQUENCE CONTROL WITH SELECT MONITOR**

NOTE:

- In the event of any trouble, the sequence control may not be operative. In such a case, activate the sequence control, referring to "OPERATIONAL GUIDELINES OF THE ABS SEQUENCE CONTROL WITH DIAGNOSIS CONNECTOR". <Ref. to 4-4 [W14D1].>
- When the diagnosis terminal is connected to the diagnosis connector, the sequence control will not operate.

- 1) Connect select monitor to data link connector beside driver's seat instrument panel lower cover.
- 2) Turn ignition switch ON.
- 3) Turn select monitor switch ON.
- 4) Put select monitor to {ABS/TCS} mode.
- 5) When {Function check sequence} is selected, 'ABS sequence control' will start.
- 6) The message 'Press Brake Pedal Firmly' is displayed as follows:
  - (1) When using the brake tester, depress brake pedal with braking force of 981 N (100 kg, 221 lb).
  - (2) When using the pressure gauge, depress brake pedal so as to make the pressure gauge indicate 3,432 kPa (35 kg/cm<sup>2</sup>, 498 psi).

**CAUTION:**  
Do not depress the clutch pedal.

- 7) When the message "Press YES" is displayed, press YES key.
- 8) Operation points will be displayed on select monitor.

**3. CONDITIONS FOR COMPLETION OF ABS SEQUENCE CONTROL**

When the following conditions develop, the ABS sequence control stops and ABS operation is returned to the normal control mode.

- 1) When the speed of at least one wheel reaches 10 km/h (6 MPH).
- 2) When terminal No. 3 or No. 6 are separated from diagnosis terminals. (When select monitor is not used.)
- 3) When the brake pedal is released during sequence control and the braking lamp switch is set to off.
- 4) When brake pedal is depressed after ignition key is turned to ON, and before ABS warning light goes out. (When select monitor is not used.)
- 5) When brake pedal is not depressed after ignition key is turned to ON, and within 0.5 seconds after ABS warning light goes out. (When select monitor is not used.)
- 6) After completion of the sequence control.
- 7) When malfunction is detected. (When select monitor is used.)

**4. CONDITIONS FOR ABS SEQUENCE CONTROL**

**NOTE:**

- When select monitor is used, control operation starts at point A. The patterns from IGN key ON to the point A show that operation is started by diagnosis connector.
- HIGH means high voltage.
- LOW means low voltage.

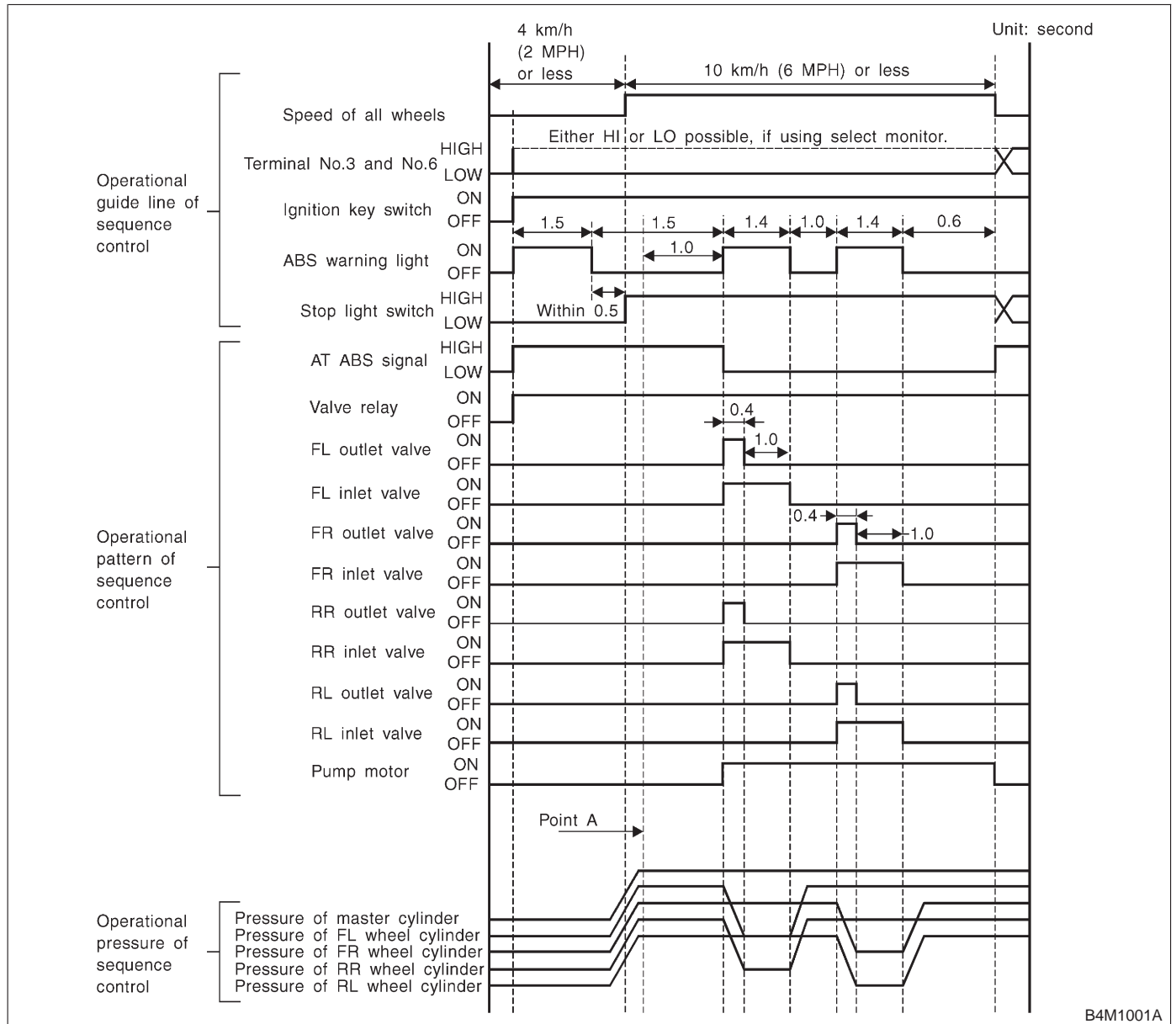

B4M1001A

**E: INSTALLATION**

1) Install ABSCM&H/U.

**CAUTION:**

Confirm that the specifications of the ABSCM&H/U conforms to the vehicle specifications.

**Tightening torque:**

**$18 \pm 5 \text{ N}\cdot\text{m}$  ( $1.8 \pm 0.5 \text{ kg}\cdot\text{m}$ ,  $13.0 \pm 3.6 \text{ ft}\cdot\text{lb}$ )**

2) Connect brake pipes to their correct ABSCM&H/U connections.

**Brake pipe tightening torque:**

**$15^{+3}_{-2} \text{ N}\cdot\text{m}$  ( $1.5^{+0.3}_{-0.2} \text{ kg}\cdot\text{m}$ ,  $10.8^{+2.2}_{-1.4} \text{ ft}\cdot\text{lb}$ )**

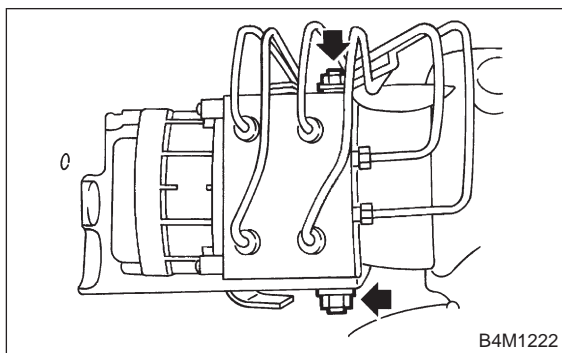

3) Using cable clip, secure ABSCM&H/U harness to bracket.

4) Connect connector to ABSCM&H/U.

**CAUTION:**

- Be sure to remove all foreign matter from inside the connector before connecting.
- Ensure that the ABSCM&H/U connector is securely locked.

5) Install air intake duct.

6) Connect ground cable to battery.

7) Bleed air from the brake system.

**15. G Sensor**

**A: REMOVAL AND INSTALLATION**

- 1) Turn ignition switch to OFF.
- 2) Remove console cover. <Ref. to 5-4 [W1A0].>
- 3) Disconnect connector from G sensor.
- 4) Remove G sensor from body.

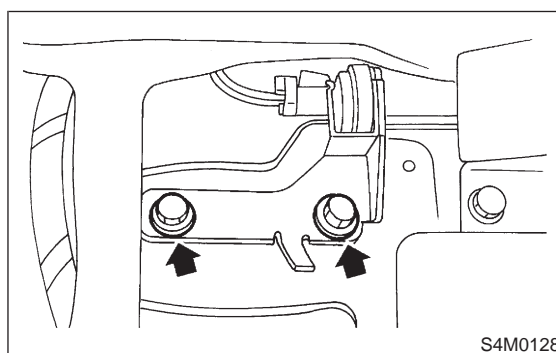

5) To install, reverse the removal procedure.

**CAUTION:**

Do not drop or bump G sensor.

**B: INSPECTION WITH CIRCUIT TESTER**

**15B1 : CHECK G SENSOR.**

- 1) Turn ignition switch to OFF.
- 2) Remove G sensor from vehicle.
- 3) Connect connector to G sensor.
- 4) Turn ignition switch to ON.
- 5) Measure voltage between G sensor connector terminals.

**Connector & terminal**

**(R70) No. 2 (+) — No. 3 (-)**

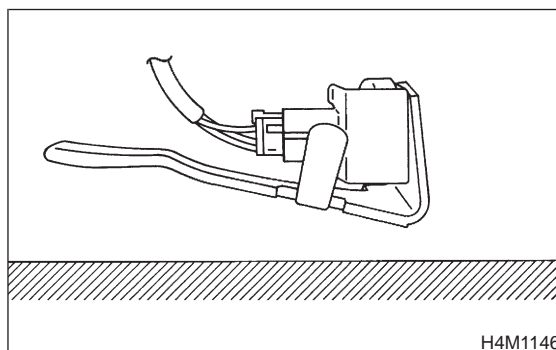

**CHECK** : Is the voltage  $2.3 \pm 0.2 \text{ V}$  when G sensor is horizontal?

**YES** : Go to step 15B2.

**NO** : Replace G sensor.