

8. Time Lag Test

A: INSPECTION

1. GENERAL INFORMATION

If the shift lever is shifted while the engine is idling, there will be a certain time elapse or lag before the shock can be felt. This is used for checking the condition of the low clutch, reverse clutch, low & reverse brake and one-way clutch.

CAUTION:

- Perform the test at normal operation fluid temperature 60 to 80°C (140 to 176°F).
- Be sure to allow a one minute interval between tests.
- Make three measurements and take the average value.

2. TEST METHODS

- 1) Fully apply the parking brake.
- 2) Start the engine.
Check idling speed (A/C OFF).
"N" range: 700±100 rpm
- 3) Shift the shift lever from "N" to "D" range.
Using a stop watch, measure the time it takes from shifting the lever until the shock is felt.
Time lag: Less than 1.2 seconds
- 4) In same manner, measure the time lag for "N" → "R".
Time lag: Less than 1.5 seconds

3. EVALUATION

- 1) If "N" → "D" time lag is longer than specified:
 - Line pressure too low
 - Low clutch worn
 - One-way clutch not operating properly
- 2) If "N" → "R" time lag is longer than specified:
 - Line pressure too low
 - Reverse clutch worn
 - Low & reverse brake worn

9. Line Pressure Test

A: MEASUREMENT

1. GENERAL INFORMATION

If the clutch or the brake shows a sign of slippage or shifting sensation is not correct, the line pressure should be checked.

- Excessive shocks during upshifting or shifting takes place at a higher point than under normal circumstances, may be due to the line pressure being too high.
 - Slippage or inability to operate the vehicle may, in most cases, be due to loss of oil pressure for the operation of the clutch, brake or control valve.
- 1) Line pressure measurement (under no load)

CAUTION:

- Before measuring line pressure, jack-up all wheels.
- Maintain temperature of ATF at approximately 50°C (122°F) during measurement. (ATF will reach the above temperature after idling the engine for approximately 30 minutes with select lever in "N" or "P".)

- 2) Line pressure measurement (under heavy load)

CAUTION:

- Before measuring line pressure, apply both foot and parking brakes with all wheels chocked (Same as for "stall" test conditions).
- Measure line pressure when select lever is in "R", "2" with engine under stall conditions.
- Measure line pressure within 5 seconds after shifting the select lever to each position. (If line pressure needs to be measured again, allow the engine to idle and then stop. Wait for at least one minute before measurement.)
- Maintain the temperature of ATF at approximately 50°C (122°F) during measurement. (ATF will reach the above temperature after idling the engine for approximately 30 minutes with the select lever in "N" or "P".)

3-2 [W9A2]

9. Line Pressure Test

SERVICE PROCEDURE

2. TEST METHODS

1) Temporarily attach the ST to a suitable place in the driver's compartment, remove the blind plug located in front of the toe board and pass the hose of the ST to the engine compartment.

ST 498575400 OIL PRESSURE GAUGE ASSY

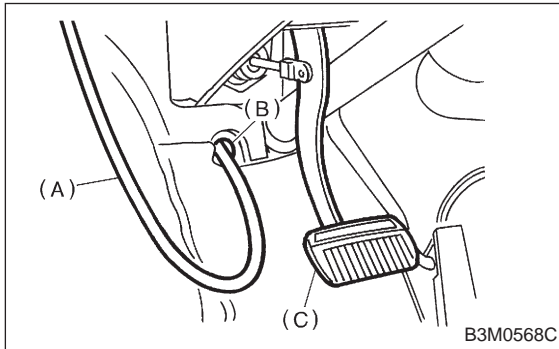

- (A) Pressure gauge hose
- (B) Hole in toe board (blank cap hole)
- (C) Brake pedal

2) Remove the test plug and install ST instead.

ST 498897200 OIL PRESSURE GAUGE ADAPTER

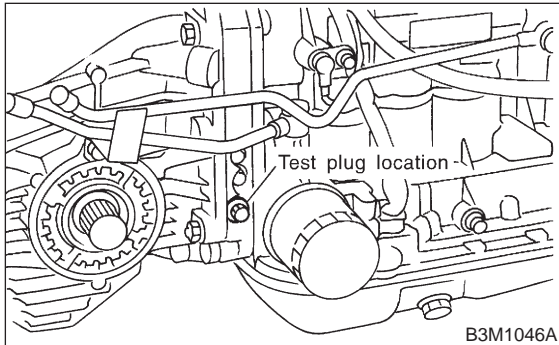

3) Connect ST1 with ST2.

ST1 498897200 OIL PRESSURE GAUGE ADAPTER

ST2 498575400 OIL PRESSURE GAUGE ASSY

4) Check for duty ratio changes by opening and closing throttle valve using Subaru Select Monitor.
(1) Insert the cartridge to Subaru Select Monitor.

ST 24082AA090 CARTRIDGE

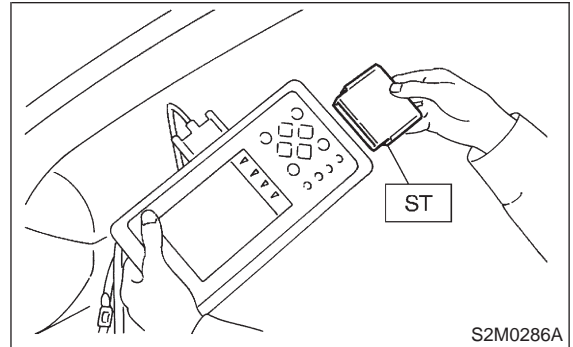

(2) Connect Subaru Select Monitor to data link connector.

5) Check line pressure in accordance with the following chart.

3. EVALUATION

NOTE:

- Under no load: "D"
 - Under full load: "R", "2"
- (With engine running at stall speed)

Standard line pressure		
Range position	Line pressure duty ratio (%)	Line pressure kPa (kg/cm ² , psi)
2	5	1,128 — 1,304 (11.5 — 13.3, 164 — 189)
R	5	1,520 — 1,716 (15.5 — 17.5, 220 — 249)
D	95	304 — 412 (3.1 — 4.2, 44 — 60)