

2. REVERSE CHECK PLATE ADJUSTMENT

- 1) Shift shifter arm to "5th" and then to reverse to see if reverse check mechanism operates properly.
- 2) Also check to see if arm returns to neutral when released from the reverse position. If arm does not return properly, replace reverse check plate.

Reverse check plate			
Part No.	(A): No.	Angle θ	Remarks
32189AA000	0	28°	Arm stops closer to 5th gear.
32189AA010	1	31°	Arm stops closer to 5th gear.
32189AA020	2	34°	Arm stops in the center.
32189AA030	3	37°	Arm stops closer to reverse gear.
32189AA040	4	40°	Arm stops closer to reverse gear.

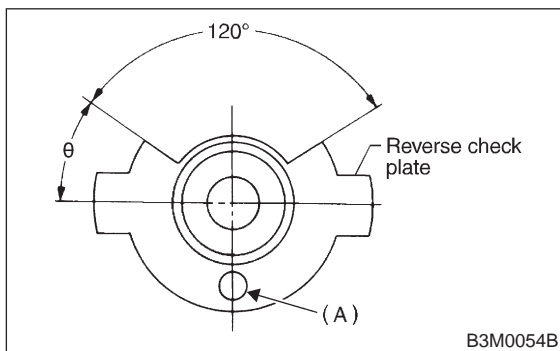

- 3) Install neutral position switch and back-up light switch to transfer case.

Tightening torque:
 $24.5 \pm 2.0 \text{ N}\cdot\text{m}$ ($2.50 \pm 0.20 \text{ kg}\cdot\text{m}$, $18.1 \pm 1.4 \text{ ft}\cdot\text{lb}$)

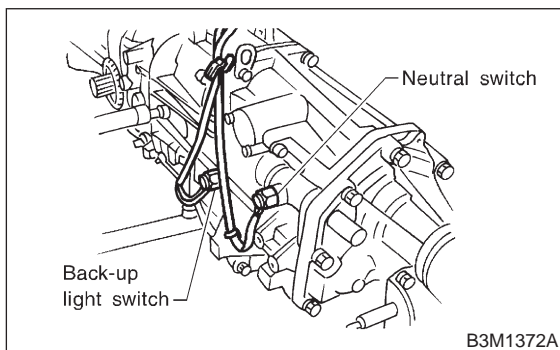

6. Front Differential

A: DISASSEMBLY

- 1) Remove right and left snap rings from differential, and then remove two axle drive shafts.

NOTE:

During reassembly, reinstall each axle drive shaft in the same place from which it was removed.

- 2) Loosen twelve bolts and remove hypoid drive gear.

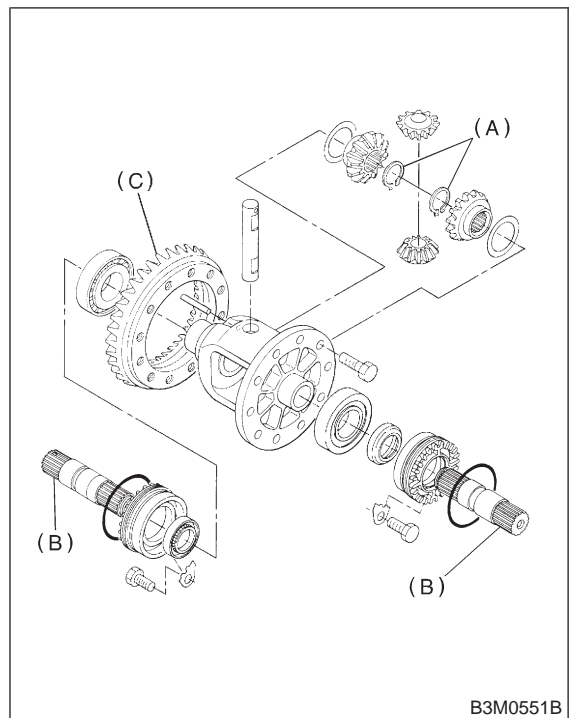

- (A) Snap ring
- (B) Axle drive shaft
- (C) Hypoid drive gear

- 3) Drive out straight pin from differential assembly toward hypoid driven gear.

ST 899904100 REMOVER

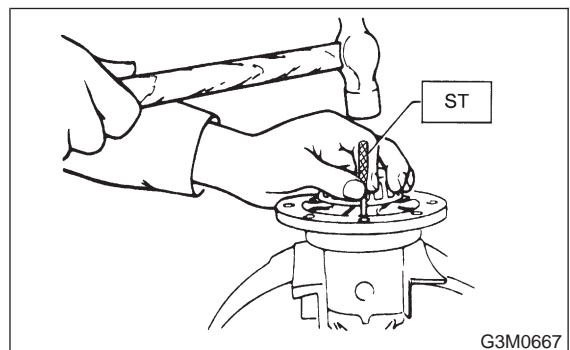

3-1 [W6B0]

6. Front Differential

SERVICE PROCEDURE

4) Pull out pinion shaft, and remove differential bevel pinion and gear and washer.

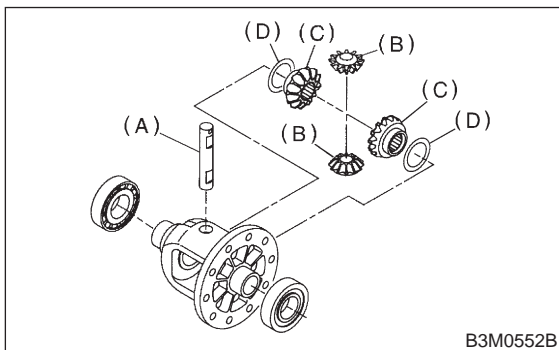

- (A) Pinion shaft
- (B) Differential bevel pinion
- (C) Differential bevel gear
- (D) Washer

5) Remove roller bearing using ST.
ST 399527700 PULLER SET

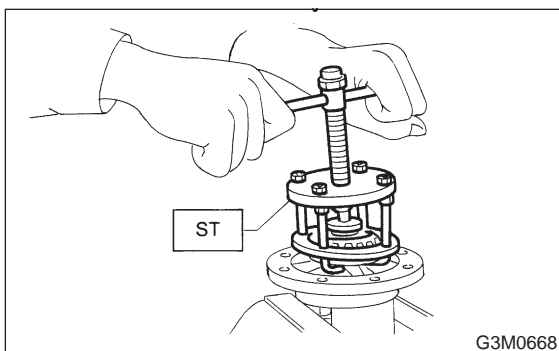

B: ASSEMBLY

1) Install bevel gear and bevel pinion together with washers, and insert pinion shaft.

NOTE:

Face the chamfered side of washer toward gear.

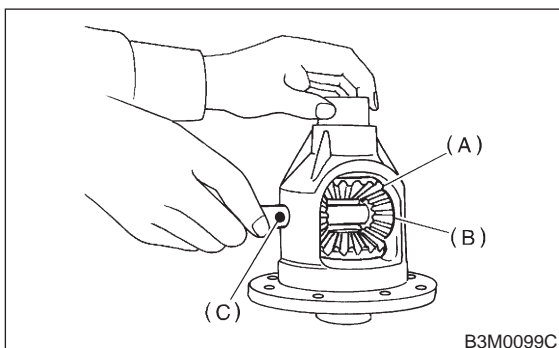

- (A) Differential bevel gear
- (B) Differential bevel pinion
- (C) Pinion shaft

2) Measure backlash between bevel gear and pinion. If it is not within specifications, install a suitable washer to adjust it.

NOTE:

Be sure the pinion gear tooth contacts adjacent gear teeth during measurement.

ST1 498247001 MAGNET BASE

ST2 498247100 DIAL GAUGE

Standard backlash:

0.13 — 0.18 mm (0.0051 — 0.0071 in)

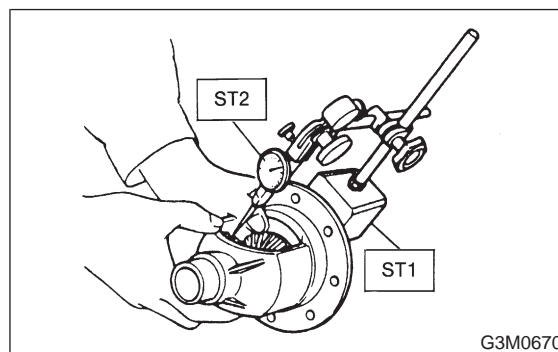

Washer (38.1 × 50 × t)	
Part No.	Thickness mm (in)
803038021	0.925 — 0.95 (0.0364 — 0.0374)
803038022	0.975 — 1.000 (0.0384 — 0.0394)
803038023	1.025 — 1.050 (0.0404 — 0.0413)

3) Align pinion shaft and differential case at their holes, and drive straight pin into holes from the hypoid driven gear side, using ST.

NOTE:

Lock straight pin after installing.

ST 899904100 REMOVER

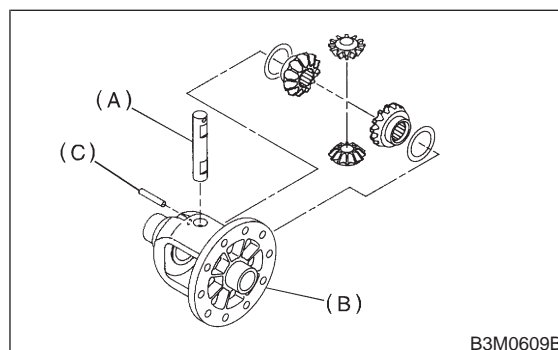

- (A) Pinion shaft
- (B) Differential case
- (C) Straight pin

4) Install roller bearing (40 × 80 × 19.75) to differential case.

NOTE:

Be careful because roller bearing outer races are used as a set.

ST1 499277100 BUSH 1-2 INSTALLER
ST2 398497701 ADAPTER

7) If it is not within specifications, replace snap ring with a suitable one.

Snap ring (Outer-28)	
Part No.	Thickness mm (in)
805028011	1.05 (0.0413)
805028012	1.20 (0.0472)

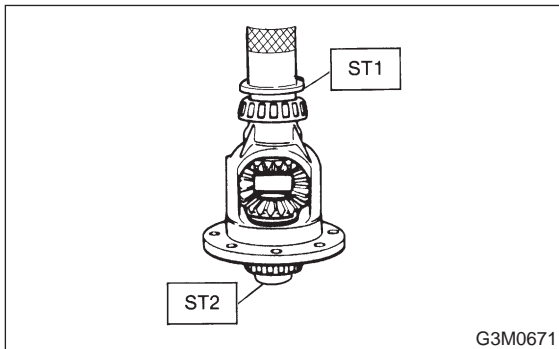

5) Install hypoid driven gear to differential case using twelve bolts.

Tightening torque:

T: 62±5 N·m (6.3±0.5 kg·m, 45.6±3.6 ft·lb)

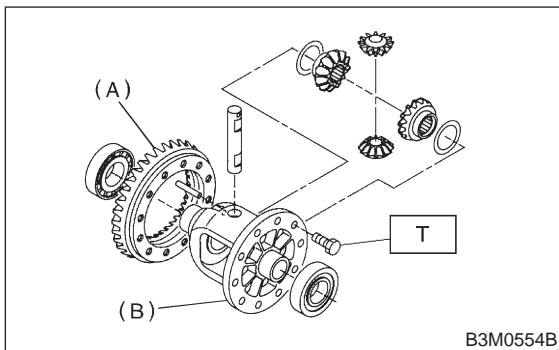

- (A) Hypoid driven gear
- (B) Differential case

6) Position drive axle shaft in differential case and hold it with outer snap ring (Outer-28). Using a thickness gauge, measure clearance between the shaft and case is within specifications.

Clearance:

0 — 0.2 mm (0 — 0.008 in)

