

## BODY SECTION

This service manual has been prepared to provide SUBARU service personnel with the necessary information and data for the correct maintenance and repair of SUBARU vehicles.

This manual includes the procedures for maintenance, disassembling, reassembling, inspection and adjustment of components and diagnostics for guidance of experienced mechanics.

Please peruse and utilize this manual fully to ensure complete repair work for satisfying our customers by keeping their vehicle in optimum condition. When replacement of parts during repair work is needed, be sure to use SUBARU genuine parts.

All information, illustration and specifications contained in this manual are based on the latest product information available at the time of publication approval.

**HVAC SYSTEM  
(HEATER, VENTILATOR AND A/C)** AC

**HVAC SYSTEM (AUTO A/C)  
(DIAGNOSTICS)** AC

**AIRBAG SYSTEM** AB

**AIRBAG SYSTEM (DIAGNOSTICS)** AB

**SEAT BELT SYSTEM** SB

**LIGHTING SYSTEM** LI

**WIPER AND WASHER SYSTEMS** WW

**ENTERTAINMENT** ET

**COMMUNICATION SYSTEM** COM

**GLASS/WINDOWS/MIRRORS** GW

**BODY STRUCTURE** BS

**INSTRUMENTATION/DRIVER INFO** IDI

**SEATS** SE

**SECURITY AND LOCKS** SL

**IMMOBILIZER (DIAGNOSTICS)** IM

**SUNROOF/T-TOP/CONVERTIBLE TOP  
(SUNROOF)** SR

**EXTERIOR/INTERIOR TRIM** EI

**BODY SECTION**

**EXTERIOR BODY PANELS**

**EB**

**CRUISE CONTROL SYSTEM**

**CC**

**CRUISE CONTROL SYSTEM  
(DIAGNOSTICS)**

**CC**

# HVAC SYSTEM (HEATER, VENTILATOR AND A/C)

# AC

---

|  | <b>Page</b> |
|--|-------------|
| 1. General Description .....                         | 2           |
| 2. Refrigerant Pressure with Manifold Gauge Set..... | 15          |
| 3. Refrigerant Recovery Procedure.....               | 16          |
| 4. Refrigerant Charging Procedure .....              | 17          |
| 5. Refrigerant Leak Check .....                      | 20          |
| 6. Compressor Oil .....                              | 22          |
| 7. Blower Motor Unit Assembly .....                  | 23          |
| 8. Power Transistor (Heater Blower Resistor).....    | 24          |
| 9. Heater Core.....                                  | 25          |
| 10. Control Unit .....                               | 26          |
| 11. Compressor.....                                  | 27          |
| 12. Condenser.....                                   | 28          |
| 13. Heater and Cooling Unit.....                     | 29          |
| 14. Evaporator.....                                  | 30          |
| 15. Hose and Tube.....                               | 31          |
| 16. Relay and Fuse .....                             | 32          |
| 17. Pressure Switch (Dual Switch).....               | 33          |
| 18. Ambient Sensor (Auto A/C).....                   | 34          |
| 19. Sun-load Sensor (Auto A/C).....                  | 35          |
| 20. Air Vent Grille .....                            | 36          |
| 21. Heater Duct .....                                | 37          |
| 22. Heater Vent Duct.....                            | 38          |
| 23. General Diagnostics.....                         | 39          |

# GENERAL DESCRIPTION

HVAC SYSTEM (HEATER, VENTILATOR AND A/C)

## 1. General Description

### A: SPECIFICATIONS

#### 1. HEATER SYSTEM

| Item  |   | Specifications                                   | Condition  |
|---|---|--|--|
| Heating capacity                              |   | 5.0 kW (4,300 kcal/h, 17,062 BTU/h) or more      | <ul style="list-style-type: none"> <li>• Mode selector switch: HEAT</li> <li>• Temperature control switch: FULL HOT</li> <li>• Temperature difference between hot water and inlet air: 65°C (149°F)</li> <li>• Hot water flow rate: 360 ℓ (95.1 US gal, 79.2 Imp gal)/h</li> </ul> |
| Air flow rate                                 |   | 280 m <sup>3</sup> (9,888 cu ft)/h               | Heat mode (FRESH), FULL HOT at 12.5 V  |
| Max air flow rate                             |   | 450 m <sup>3</sup> (15,892 cu ft)/h              | <ul style="list-style-type: none"> <li>• Temperature control switch: FULL COLD</li> <li>• Blower fan speed: 4th position</li> <li>• Mode selector lever: RECIRC</li> </ul>   |
| Heater core size<br>(height × length × width) |   | LHD model  | —  |
|   |   | RHD model  |  |
| Blower motor                                  | Type                                    | Magnet motor 200 W or less                       | at 12 V  |
|   | Fan type and size<br>(diameter × width) | Sirocco fan type<br>150 × 75 mm (5.91 × 2.95 in) | —  |

# GENERAL DESCRIPTION

HVAC SYSTEM (HEATER, VENTILATOR AND A/C)

## 2. A/C SYSTEM

### • LHD Model:

| Item  |  | Specifications   |   |
|---|--|--|---|
| Type of air conditioner   |  | Reheat air-mix type  |   |
| Cooling capacity  |  | 5.1 kW<br>(4,385 kcal/h, 17,402 BTU/h)                                       |   |
| Refrigerant   |  | HFC-134a (CH <sub>2</sub> FCF <sub>3</sub> )<br>[0.5±0.05 kg (0.99±0.11 lb)] |   |
| Compressor  | Type                                       | Vane rotary, fix volume (CR-14)  |   |
|   | Discharge                                  | 144 cm <sup>3</sup> (8.79 cu in)/rev   |   |
|   | Max. permissible speed                     | 7,000 rpm  |   |
| Magnet clutch   | Type                                       | Dry, single-disc type  |   |
|   | Power consumption                          | 47 W   |   |
|   | Type of belt                               | V-Ribbed 4 PK  |   |
|   | Pulley dia. (effective dia.)               | 125 mm (4.92 in)   |   |
| Condenser   | Pulley ratio                               | 1.064  |   |
|   | Type                                       | Corrugated fin (Sub cool type)   |   |
|   | Core face area                             | 0.21 m <sup>2</sup> (2.26 sq ft)   |   |
|   | Core thickness                             | 16 mm (0.63 in)  |   |
| Receiver drier  | Radiation area                             | 6.52 m <sup>2</sup> (70 sq ft)   |   |
|   | Effective inner capacity                   | 250 cm <sup>3</sup> (15.26 cu in)  |   |
| Expansion valve   | Type                                       | Internal equalizing  |   |
| Evaporator  | Type                                       | Single tank  |   |
|   | Dimensions (W × H × T)                     | 255 × 200 × 48 mm<br>(10 × 7.87 × 1.89 in)                                   |   |
| Blower fan  | Fan type                                   | Sirocco fan  |   |
|   | Outer diameter × width                     | 150 × 75 mm (5.91 × 2.95 in)   |   |
|   | Power consumption                          | 200 W at 12 V  |   |
| Condenser fan (Sub fan)   | Motor type                                 | Magnet   |   |
|   | Power consumption                          | 70 W at 12 V   |   |
|   | Fan outer diameter                         | 320 mm (12.6 in)   |   |
| Radiator fan (Main fan)   | Motor type                                 | Magnet   |   |
|   | Power consumption                          | 70 W at 12 V   |   |
|   | Fan outer diameter                         | 320 mm (12.6 in)   |   |
| Idling speed (A/C ON)   |  | MPFI model<br>850±100 rpm  |   |
| Dual switch<br>(Pressure switch)  | Low-pressure switch<br>operating pressure  | ON → OFF   | 278±29 kPa<br>(2.83±0.3 kg/cm <sup>2</sup> , 40.3±4.2 psi)  |
|   |  | OFF → ON   | 287 <sup>+39</sup> / <sub>-25</sub> kPa<br>(2.9 <sup>+0.4</sup> / <sub>-0.25</sub> kg/cm <sup>2</sup> , 42 <sup>+5.7</sup> / <sub>-3.6</sub> psi) |
|   | High-pressure switch<br>operating pressure | ON → OFF   | 2,800±100 kPa<br>(29±1 kg/cm <sup>2</sup> , 406±15 psi)   |
|   |  | DIFF   | 600±200 kPa<br>(6.12±2 kg/cm <sup>2</sup> , 87±29 psi)  |
| Thermo control amplifier working temperature<br>(Evaporator outlet air) |  | <p>Diff. 2.5±0.5°C(36.5±0.9°F)</p> <p>ON</p> <p>OFF 1.5±0.5°C(35±0.9°F)</p>  |   |

HV0045

# GENERAL DESCRIPTION

## HVAC SYSTEM (HEATER, VENTILATOR AND A/C)

• **RHD Model:**

| Item  |  | Specifications  |   |
|---|--|---|---|
| Type of air conditioner   |  | Reheat air-mix type   |   |
| Cooling capacity  |  | 5.1 kW (4,385 kcal/h, 17,402 BTU/h)   |   |
| Refrigerant   |  | HFC-134a (CH <sub>2</sub> FCF <sub>3</sub> )<br>[0.5±0.05 kg (1.10±0.11 lb)]  |   |
| Compressor  | Type                                       | Vane rotary, fix volume (CR-14)   |   |
|   | Discharge                                  | 144 cm <sup>3</sup> (8.79 cu in)/rev  |   |
|   | Max. permissible speed                     | 7,000 rpm   |   |
| Magnet clutch   | Type                                       | Dry, single-disc type   |   |
|   | Power consumption                          | 47 W  |   |
|   | Type of belt                               | V-Ribbed 4 PK   |   |
|   | Pulley dia. (effective dia.)               | 125 mm (4.92 in)  |   |
|   | Pulley ratio                               | 1.064   |   |
| Condenser   | Type                                       | Corrugated fin (Sub cool type)  |   |
|   | Core face area                             | 0.21 m <sup>2</sup> (2.26 sq ft)  |   |
|   | Core thickness                             | 16 mm (0.63 in)   |   |
|   | Radiation area                             | 5.34 m <sup>2</sup> (57.48 sq ft)   |   |
| Receiver drier  | Effective inner capacity                   | 250 cm <sup>3</sup> (15.26 cu in)   |   |
| Expansion valve   | Type                                       | Externally equalizing   |   |
| Evaporator  | Type                                       | Single tank   |   |
|   | Dimensions (W × H × T)                     | 255 × 200 × 48 mm<br>(10 × 7.87 × 1.89 in)  |   |
| Blower fan  | Fan type                                   | Sirocco fan   |   |
|   | Outer diameter × width                     | 150 × 75 mm (5.91 × 2.95 in)  |   |
|   | Power consumption                          | 200 W at 12 V   |   |
| Condenser fan (Sub fan)   | Motor type                                 | Magnet  |   |
|   | Power consumption                          | 70 W at 12 V  |   |
|   | Fan outer diameter                         | 320 mm (12.6 in)  |   |
| Radiator fan (Main fan)   | Motor type                                 | Magnet  |   |
|   | Power consumption                          | 70 W at 12 V  |   |
|   | Fan outer diameter                         | 320 mm (12.6 in)  |   |
| Idling speed (A/C ON)   | MPFI model                                 | 850±100 rpm   |   |
| Dual switch<br>(Pressure switch)  | Low-pressure switch<br>operating pressure  | ON → OFF  | 278±29 kPa<br>(2.83±0.3 kg/cm <sup>2</sup> , 40.3±4.2 psi)  |
|   |  | OFF → ON  | 287 <sup>+39</sup> / <sub>-25</sub> kPa<br>(2.9 <sup>+0.4</sup> / <sub>-0.25</sub> kg/cm <sup>2</sup> , 42 <sup>+5.7</sup> / <sub>-3.6</sub> psi) |
|   | High-pressure switch<br>operating pressure | ON → OFF  | 2,800±100 kPa<br>(29±1 kg/cm <sup>2</sup> , 406±15 psi)   |
|   |  | DIFF  | 600±200 kPa<br>(6.12±2 kg/cm <sup>2</sup> , 87±29 psi)  |
| Thermo control amplifier working temperature<br>(Evaporator outlet air) |  | <p style="text-align: center;">             OFF ————— ON<br/>             3.0 ± 0.5°C (37 ± 0.9°F)<br/>             Diff. 1.5 ± 0.5°C (35 ± 0.9°F)         </p> |   |

G4M0938

# GENERAL DESCRIPTION

HVAC SYSTEM (HEATER, VENTILATOR AND A/C)

## B: COMPONENT

### 1. HEATER COOLING UNIT

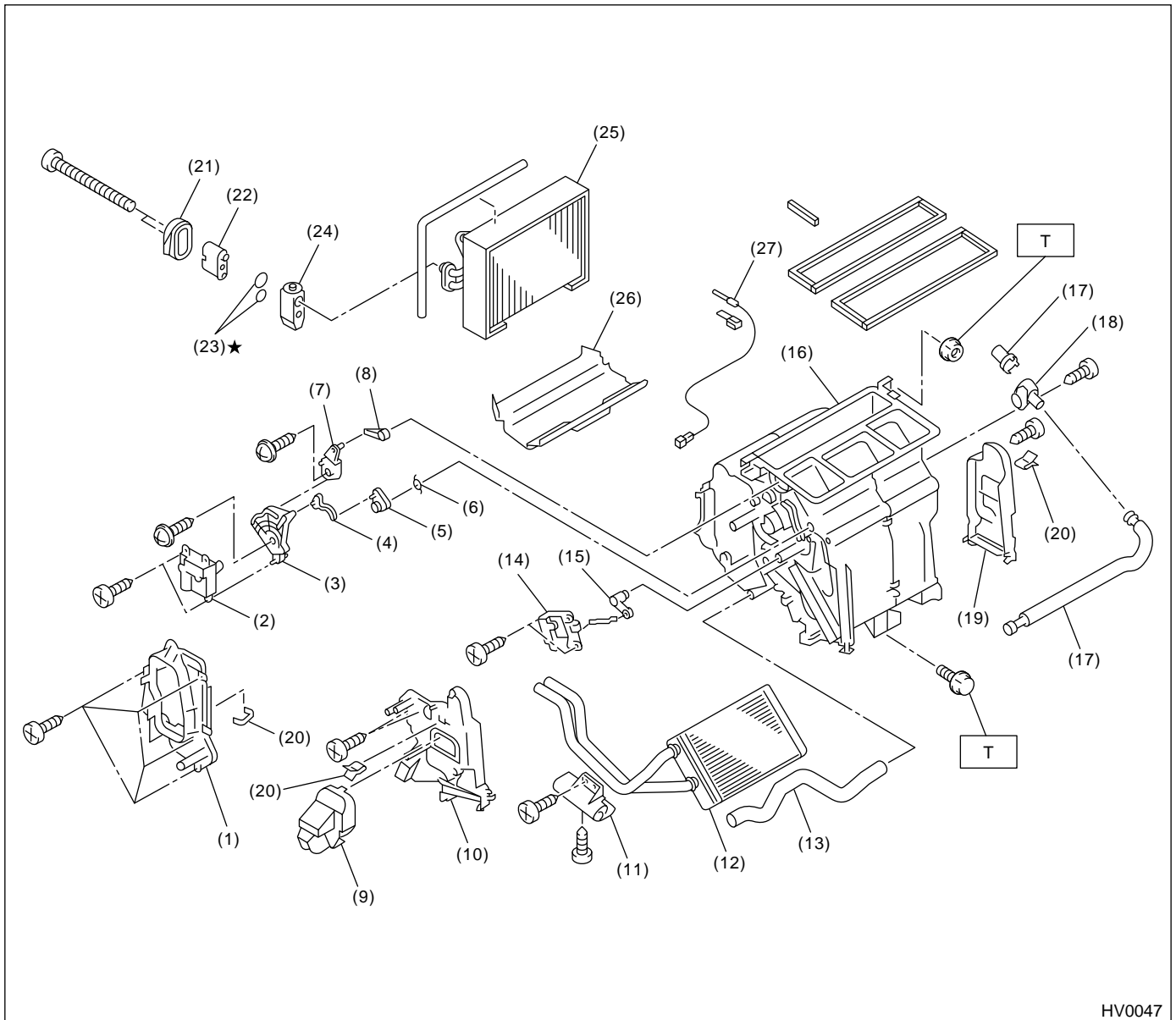

- |                        |                        |                         |
|------------------------|------------------------|-------------------------|
| (1) Unit cover         | (11) Heater core clamp | (21) Packing            |
| (2) Mode acuator       | (12) Heater core       | (22) Cooling unit block |
| (3) Side link          | (13) Drain hose        | (23) O-ring             |
| (4) Mode acuator lever | (14) Mix acuator       | (24) Expansion valve    |
| (5) Foot lever         | (15) Mix acuator lever | (25) Evaporator         |
| (6) Spring             | (16) Unit assembly     | (26) Evaporator cover   |
| (7) Mode acuator link  | (17) Aspirator hose    | (27) Thermistor         |
| (8) Defroster lever    | (18) Aspirator         |                         |
| (9) Foot nozzle        | (19) Foot duct         |                         |
| (10) Unit duct cover   | (20) Clip              |                         |

**Tightening torque: N·m (kgf·m, ft·lb)**

**T: 7.35 (0.750, 5.421)**

# GENERAL DESCRIPTION

HVAC SYSTEM (HEATER, VENTILATOR AND A/C)

## 2. BLOWER MOTER UNIT

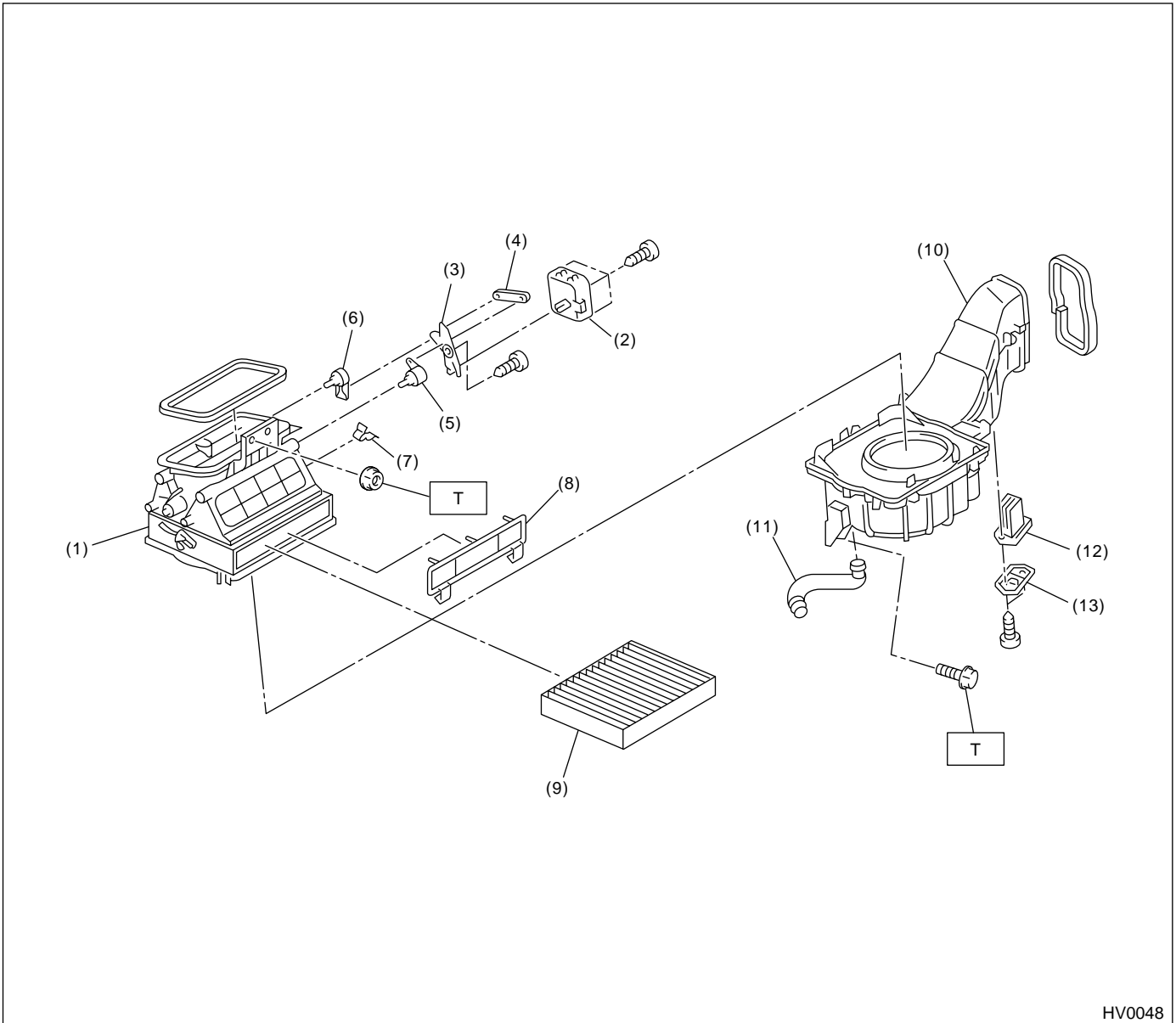

- |                         |                            |
|-------------------------|----------------------------|
| (1) Upper case          | (7) Clip                   |
| (2) Servo motor         | (8) Filter cover           |
| (3) Blower link         | (9) Filter                 |
| (4) Blower link lever A | (10) Blower motor assembly |
| (5) Blower link lever B | (11) Hose                  |
| (6) Blower link lever C | (12) Power transistor      |

- (13) Power transistor cover

**Tightening torque: N·m (kgf·m, ft·lb)**

**T: 7.35 (0.750, 5.421)**



# GENERAL DESCRIPTION

HVAC SYSTEM (HEATER, VENTILATOR AND A/C)

## 3. CONTROL UNIT

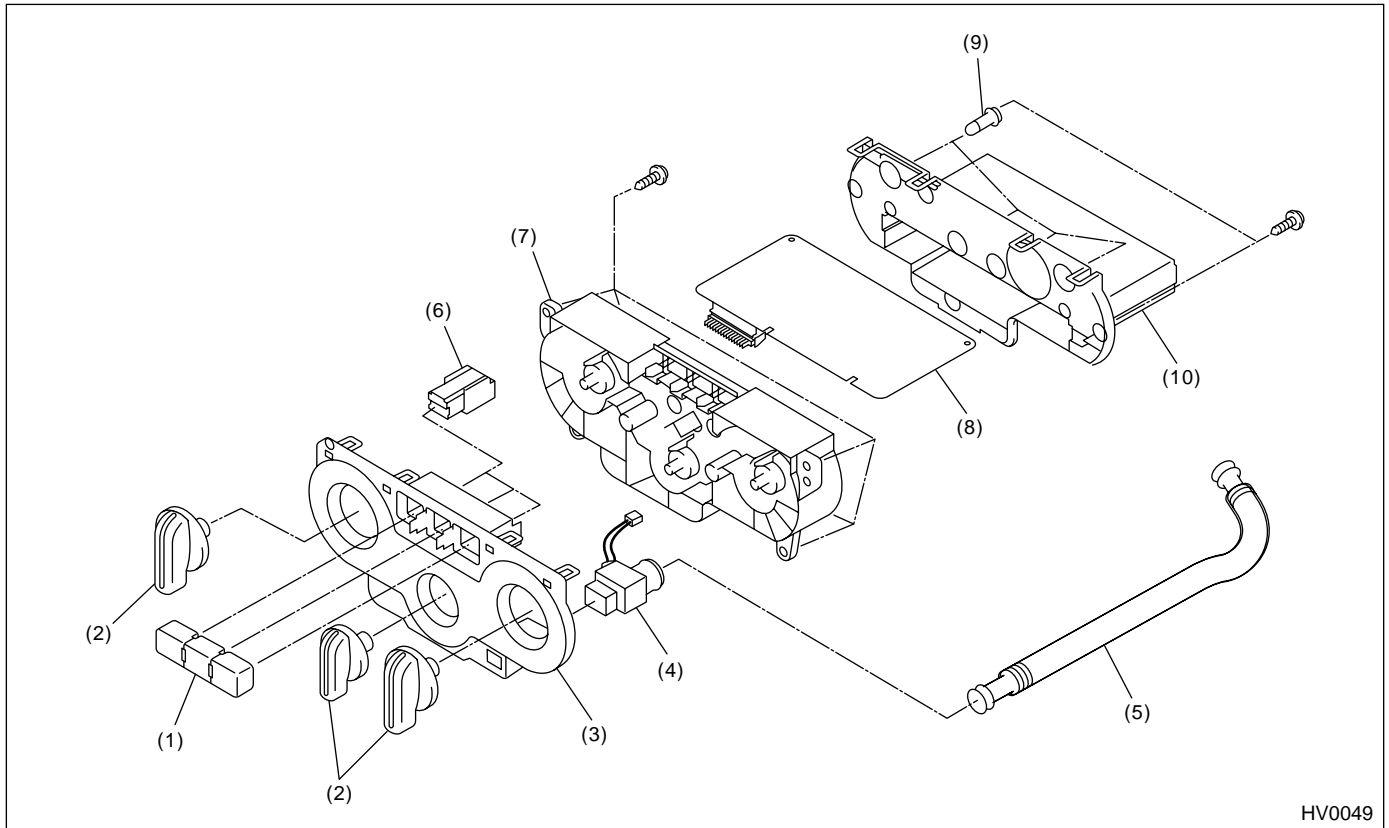

HV0049

- |                   |                             |
|-------------------|-----------------------------|
| (1) Switch        | (6) Switch assembly         |
| (2) Control lever | (7) Control base            |
| (3) Control panel | (8) Electronic control unit |
| (4) In-car sensor | (9) Bulb                    |
| (5) Hose          | (10) Control case           |

# GENERAL DESCRIPTION

HVAC SYSTEM (HEATER, VENTILATOR AND A/C)

## 4. AIR CONDITIONING UNIT

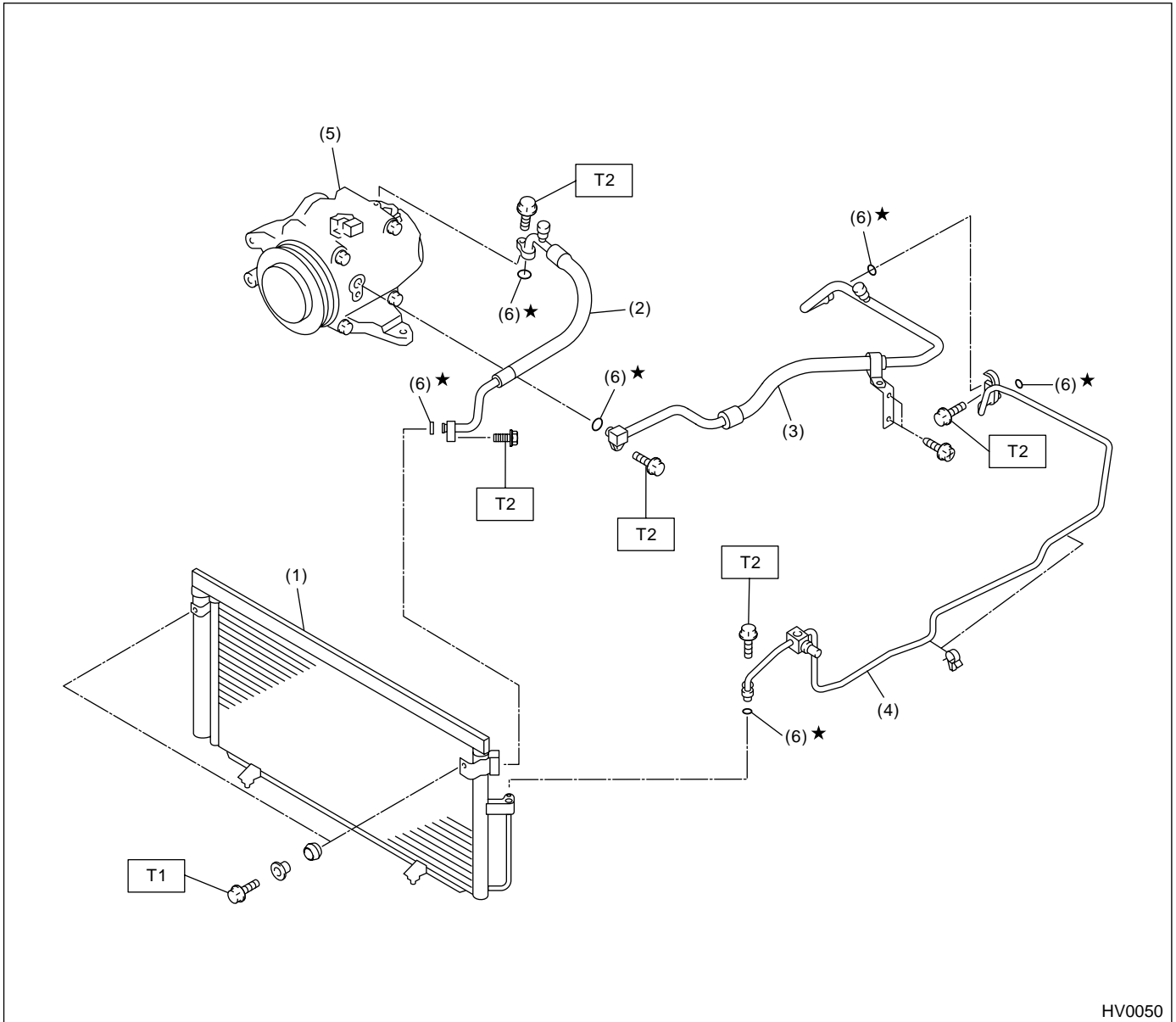

HV0050

- |                            |                |
|----------------------------|----------------|
| (1) Condenser              | (4) Tube       |
| (2) Hose (High — pressure) | (5) Compressor |
| (3) Hose (Low — pressure)  | (6) O-ring     |

**Tightening torque: N·m (kgf·m, ft·lb)**

**T1: 7.4 (0.75, 5.4)**

**T2: 15 (1.5, 10.8)**

# GENERAL DESCRIPTION

HVAC SYSTEM (HEATER, VENTILATOR AND A/C)

## 5. COMPRESSOR

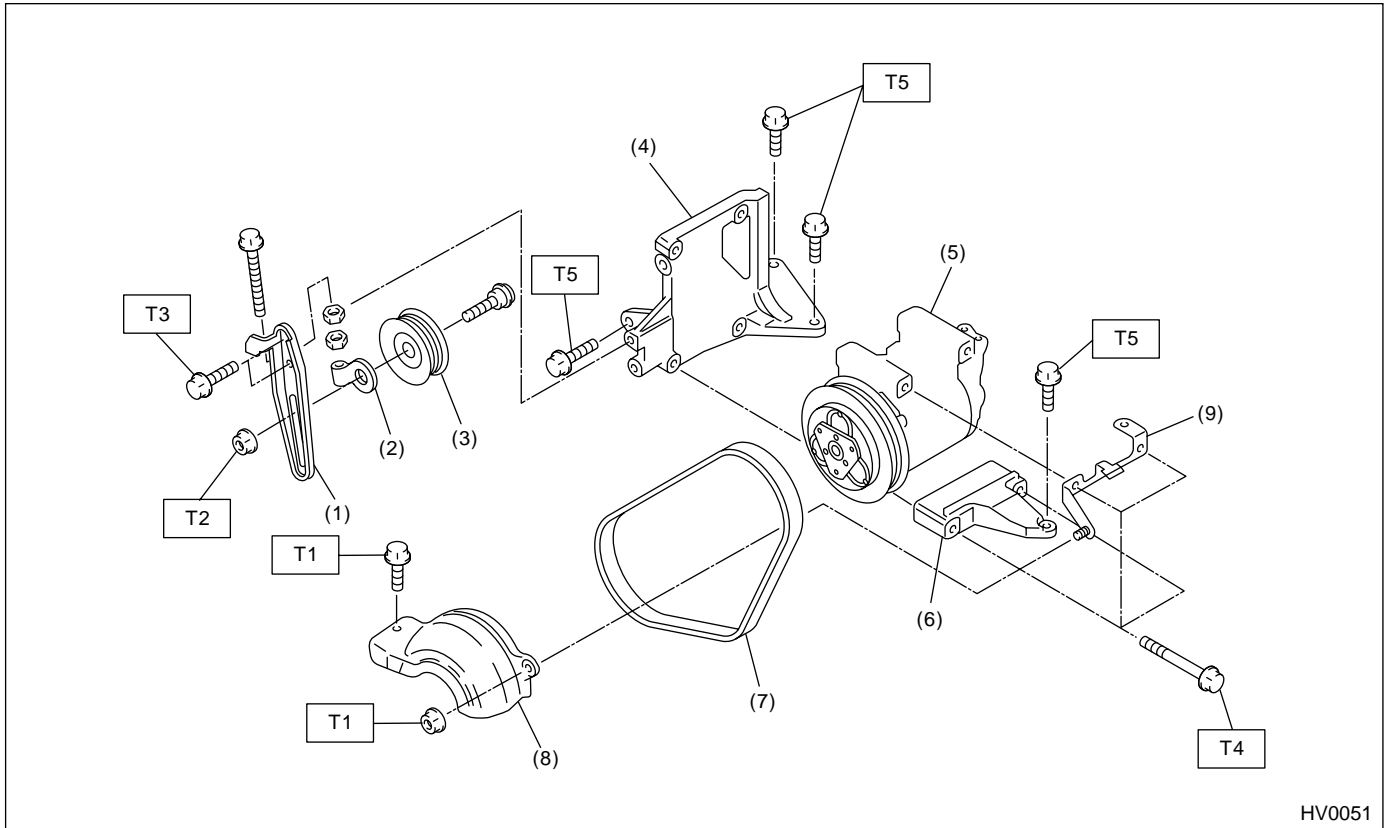

HV0051

- |                              |                           |
|------------------------------|---------------------------|
| (1) Idler pulley bracket     | (7) V-belt                |
| (2) Idler pulley adjuster    | (8) Compressor belt cover |
| (3) Idler pulley             |                           |
| (4) Compressor bracket upper |                           |
| (5) Compressor               |                           |
| (6) Compressor bracket lower |                           |

**Tightening torque: N·m (kgf·m, ft·lb)**

- |                              |
|------------------------------|
| <b>T1: 7.4 (0.75, 5.4)</b>   |
| <b>T2: 22.6 (2.3, 16.6)</b>  |
| <b>T3: 23.0 (2.35, 17.0)</b> |
| <b>T4: 28.9 (2.95, 21.3)</b> |
| <b>T5: 35 (3.6, 26)</b>      |

# GENERAL DESCRIPTION

HVAC SYSTEM (HEATER, VENTILATOR AND A/C)

## C: CAUTION

### 1. HFC-134A A/C SYSTEM

- Unlike the old conventional HFC-12 system components, the cooling system components for the HFC-134a system such as the refrigerant and compressor oil are incompatible.
- Vehicles with the HFC-134a system can be identified by the label “A” attached to the vehicle. Before maintenance, check which A/C system is installed in the vehicle.

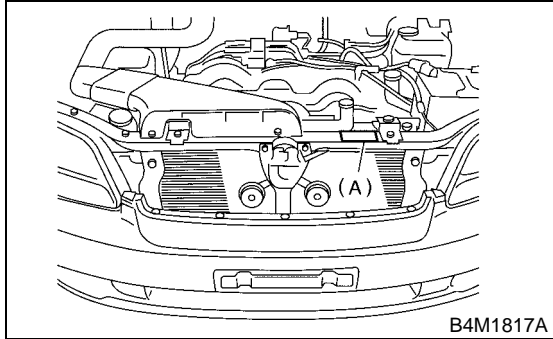

### 2. COMPRESSOR OIL

- HFC-134a compressor oil has no compatibility with that for R12 system.
  - Use only the manufacturer-authorized compressor oil for the HFC-134a system; only use DH-PR.
  - Do not mix multiple compressor oils.
- If HFC-12 compressor oil is used in a HFC-134a A/C system, the compressor may become stuck due to poor lubrication, or the refrigerant may leak due to swelling of rubber parts.
- On the other hand, if HFC-134a compressor oil is used in a HFC-12 A/C system, the durability of the A/C system will be lowered.
- HFC-134a compressor oil is very hygroscopic. When replacing or installing/removing A/C parts, immediately isolate the oil from the atmosphere using a plug or tape. In order to avoid moisture, store the oil in a container with its cap tightly closed.

### 3. REFRIGERANT

- The HFC-12 refrigerant cannot be used in the HFC-134a A/C system. The HFC-134a refrigerant, also, cannot be used in the HFC-12 A/C system.
- If an incorrect or no refrigerant is used, poor lubrication will result and the compressor itself may be damaged.

### 4. HANDLING OF REFRIGERANT

- The refrigerant boils at approx.  $-30^{\circ}\text{C}$  ( $-22^{\circ}\text{F}$ ). When handling it, be sure to wear safety goggles and protective gloves. Direct contact of the refrigerant with skin may cause frostbite. If the refrigerant gets into your eye, avoid rubbing your eyes with your hands. Wash your eye with plenty of water, and receive medical treatment from an eye doctor.
- Do not heat a service can. If a service can is directly heated, or put into boiling water, the inside pressure will become extremely high. This may cause the can to explode. If a service can must be warmed up, use hot water in  $40^{\circ}\text{C}$  ( $104^{\circ}\text{F}$ ) max.
- Do not drop or impact a service can. (Observe the precautions and operation procedure described on the refrigerant can.)
- When the engine is running, do not open the high-pressure valve of the manifold gauge. The high-pressure gas will back-flow resulting in an explosion of the can.
- The refrigerant is non-toxic and harmless under normal operating circumstance, but it may change to phosgene (a noxious fume) under open flames or high temperatures (caused by a cigarette or heater).
- Provide good ventilation and do not work in a closed area.
- Never perform a gas leak test using a halide torch-type leak tester.
- In order to avoid destroying the ozone layer, prevent HFC-134a from being released into the atmosphere. Using a refrigerant recovery system, discharge and reuse it.

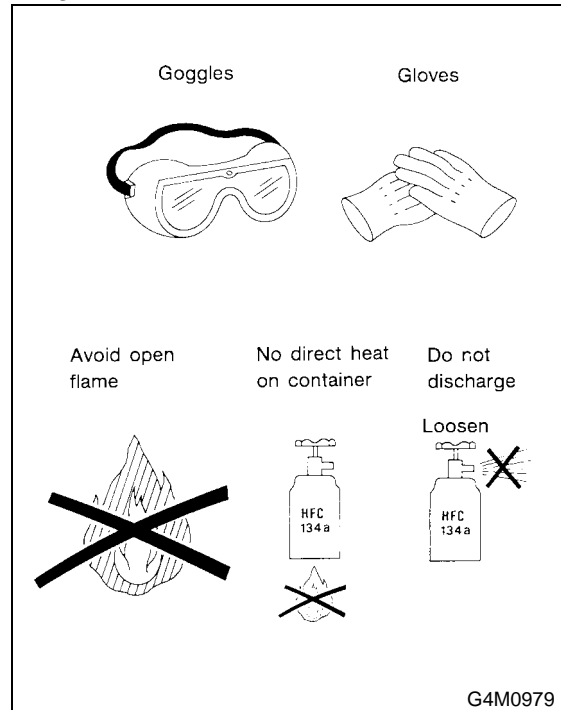

# GENERAL DESCRIPTION

HVAC SYSTEM (HEATER, VENTILATOR AND A/C)

## 5. O-RING CONNECTIONS

- Use new O-rings.
- In order to keep the O-rings free of lint which will cause a refrigerant gas leak, perform operations without gloves and shop towels.
- Apply the compressor oil to the O-rings to avoid sticking, then install them.
- Use a torque wrench to tighten the O-ring fittings: Over-tightening will damage the O-ring and tube end distortion.
- If the operation is interrupted before completing a pipe connection, recap the tubes, components, and fittings with a plug or tape to prevent contamination from entering.

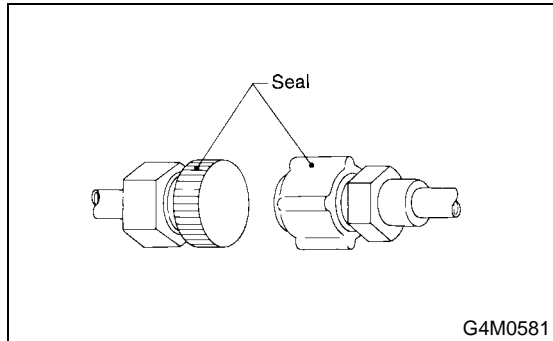

- Visually check the surfaces and mating surfaces of O-rings, threads, and connecting points. If a failure is found, replace the applicable parts.
- Install the O-rings at right angle to the tube beads.

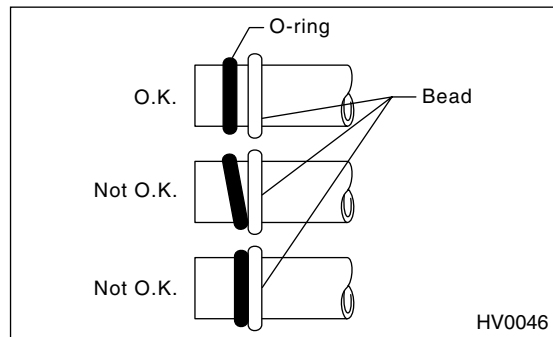

- Use the oil specified in the service manual to lubricate the O-rings. Apply the oil to the top and sides of the O-rings before installation.

Apply the oil to the area including the O-rings and tube beads.

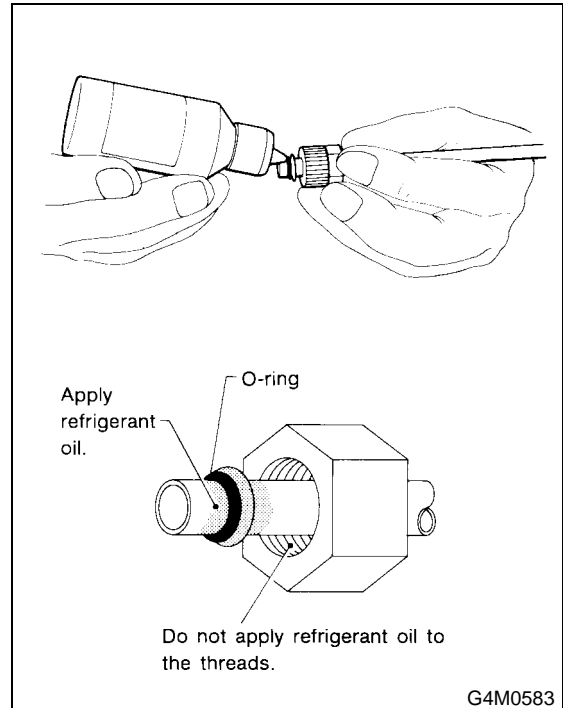

- When connecting hoses or pipes, use 2 wrenches (a torque wrench for tightening). While securing one side with a wrench, tighten the other side to the specified torque with a torque wrench. If only one wrench is used to tighten, the tightening torque will be excessive or insufficient. This may cause a pipe distortion or gas leak, resulting in damage to hoses and pipes.
- After tightening, using a clean shop towel to remove excess oil from the connections and any oil which may have run on the vehicle body or other parts.
- If any leakage is suspected after tightening, do not retighten the connections, Disconnect the connections, remove the O-rings, and check the O-rings, threads, and connections.

# GENERAL DESCRIPTION

HVAC SYSTEM (HEATER, VENTILATOR AND A/C)

## D: PREPARATION TOOL

### CAUTION:

When working on vehicles with the HFC-134a system, only use HFC-134a specified tools and parts. Do not mix with CFC-12 tools and parts. If HFC-134a and CFC-12 refrigerant or compressor oil is mixed, poor lubrication will result and the compressor itself may be destroyed.

In order to help prevent mixing HFC-134a and CFC-12 parts and liquid, the tool and screw type and the type of service valves used are different. The gas leak detectors for the HFC-134a and CFC-12 systems must also not be interchanged.

|                   | HFC-134a         | CFC-12        |
|-------------------|------------------|---------------|
| Tool & screw type | Millimeter size  | Inch size     |
| Valve type        | Quick joint type | Screw-in type |

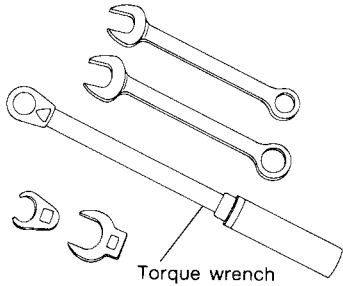
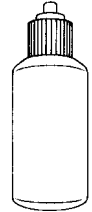
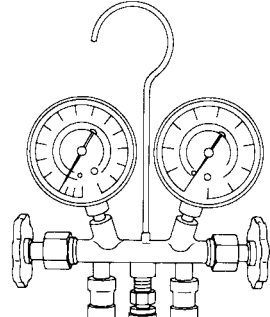
| Tools and Equipment   | Description   |
|---|---|
| <p><b>Wrench</b></p> <p>Various <b>WRENCHES</b> will be required to service any A/C system. A 7 to 40 N-m (0.7 to 4.1 kg-m, 5 to 30 ft-lb) torque wrench with various crow-foot wrenches will be needed. Open end or flare nut wrenches will be needed for back-up on the tube and hose fittings.</p> |  <p style="text-align: right;">G4M0571</p>   |
| <p><b>Applicator bottle</b></p> <p>A small <b>APPLICATOR BOTTLE</b> is recommended to apply refrigerant oil to the various parts. They can be obtained at a hardware or drug store.</p>   |  <p style="text-align: right;">G4M0572</p> |
| <p><b>Manifold gauge set</b></p> <p>A <b>MANIFOLD GAUGE SET</b> (with hoses) can be obtained from either a commercial refrigeration supply house or from an auto shop equipment supplier.</p>   |  <p style="text-align: right;">G4M0573</p> |

# GENERAL DESCRIPTION

HVAC SYSTEM (HEATER, VENTILATOR AND A/C)

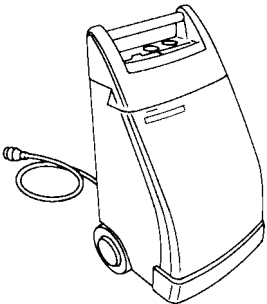
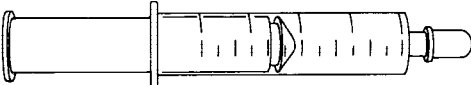
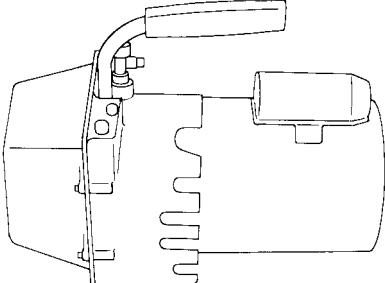
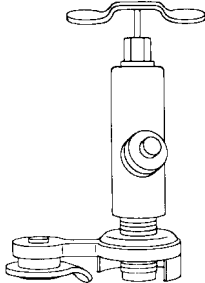
| Tools and Equipment   | Description  |
|---|--|
| <p>Refrigerant recovery system</p> <p>A <b>REFRIGERANT RECOVERY SYSTEM</b> is used for the recovery and reuse of A/C system refrigerant after contaminants and moisture have been removed from the refrigerant.</p> |  <p>G4M0574</p>   |
| <p>Syringe</p> <p>A graduated plastic <b>SYRINGE</b> will be needed to add oil back into the system. The syringe can be found at a pharmacy or drug store.</p>  |  <p>G4M0575</p>    |
| <p>Vacuum pump</p> <p>A <b>VACUUM PUMP</b> (in good working condition) is necessary, and may be obtained from either a commercial refrigeration supply house or an automotive equipment supplier.</p>               |  <p>G4M0576</p> |
| <p>Can tap</p> <p>A <b>CAN TAP</b> for the 397 g (14 oz) can is available from an auto supply store.</p>  |  <p>G4M0577</p> |

# GENERAL DESCRIPTION

## HVAC SYSTEM (HEATER, VENTILATOR AND A/C)

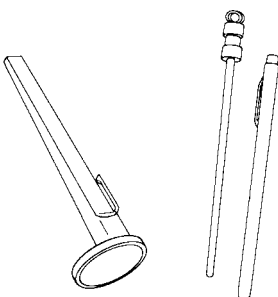
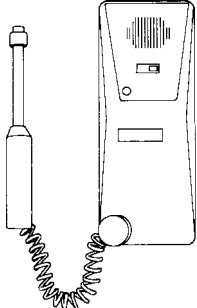
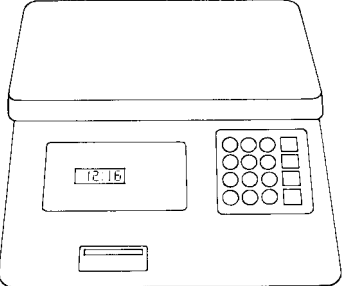
| Tools and Equipment   | Description  |
|---|--|
| <p>Thermometer</p> <p>Pocket <b>THERMOMETERS</b> are available from either industrial hardware store or commercial refrigeration supply houses.</p>   |  <p style="text-align: right;">G4M0578</p>  |
| <p>Electronic leak detector</p> <p>An <b>ELECTRONIC LEAK DETECTOR</b> can be obtained from either a specialty tool supply or an A/C equipment supplier.</p>                                       |  <p style="text-align: right;">G4M0579</p>  |
| <p>Weight scale</p> <p>A <b>WEIGHT SCALE</b> such as an electronic charging scale or a bathroom scale with digital display will be needed if a 13.6 kg (30 lb) refrigerant container is used.</p> |  <p style="text-align: right;">G4M0580</p> |



# REFRIGERANT PRESSURE WITH MANIFOLD GAUGE SET

HVAC SYSTEM (HEATER, VENTILATOR AND A/C)

## 2. Refrigerant Pressure with Manifold Gauge Set

### A: OPERATION

- 1) Place the vehicle in the shade and draftless condition.
- 2) Connect the manifold gauge set.
- 3) Open the front windows and close all doors.
- 4) Open the hood.
- 5) Increase engine rpm to 1,500.
- 6) Turn ON the A/C switch.
- 7) Turn the temperature control switch to MAX COOL.
- 8) Put in RECIRC position.
- 9) Turn the blower control switch to HI.
- 10) Read the gauge.

#### **Standard:**

**Low pressure: 127 - 196 kPa (1.3 - 2.0 kg/cm<sup>2</sup>, 18 - 28 psi)**

**High pressure: 1,471 - 1,667 kPa (15 - 17 kg/cm<sup>2</sup>, 213 - 242 psi)**

**Ambient temperature: 30 - 35 °C (86 - 95 °F)**

### B: INSPECTION

| Symptom                               | Probable cause  | Repair order   |
|---------------------------------------|---|--|
| High-pressure side is unusually high. | <ul style="list-style-type: none"><li>• Defective condenser fan motor</li><li>• Clogged condenser fan</li><li>• Too much refrigerant</li><li>• Air inside the system</li><li>• Defective receiver dryer</li></ul> | <ul style="list-style-type: none"><li>• Replace the fan motor.</li><li>• Clean the condenser fin.</li><li>• Discharge refrigerant.</li><li>• Replace the receiver dryer.</li></ul> |
| High-pressure side is unusually low.  | <ul style="list-style-type: none"><li>• Defective compressor</li><li>• Not enough refrigerant</li><li>• Clogged expansion valve</li><li>• Expansion valve frozen temporarily by moisture</li></ul>                | <ul style="list-style-type: none"><li>• Replace the compressor.</li><li>• Check for leaks.</li><li>• Replace the expansion valve.</li></ul>  |
| Low-pressure side is unusually high.  | <ul style="list-style-type: none"><li>• Defective compressor</li><li>• Defective expansion valve</li><li>• Too much refrigerant</li></ul>   | <ul style="list-style-type: none"><li>• Replace the compressor.</li><li>• Replace the expansion valve.</li><li>• Discharge refrigerant.</li></ul>                                  |
| Low-pressure side is unusually low.   | <ul style="list-style-type: none"><li>• Not enough refrigerant</li><li>• Clogged expansion valve</li><li>• Expansion valve frozen temporarily by moisture</li><li>• Saturated receiver dryer</li></ul>            | <ul style="list-style-type: none"><li>• Check for leaks.</li><li>• Replace the expansion valve</li><li>• Replace the receiver dryer.</li></ul>                                     |

# REFRIGERANT RECOVERY PROCEDURE

HVAC SYSTEM (HEATER, VENTILATOR AND A/C)

## 3. Refrigerant Recovery Procedure

### A: OPERATION

#### CAUTION:

- During operation, be sure to wear safety goggles and protective gloves.
- Connect the refrigerant recovery system with the manifold gauge set to discharge the refrigerant from the A/C system and reuse it.
- When reusing the discharged refrigerant, keep service cans on hand. Because the discharge rate with the recovery system is approx. 90%, service cans are necessary to charge the refrigerant.
- Follow the detailed operation procedure described in the operation manual attached to the refrigerant recovery system.

1) Turn the A/C switch ON.

Leave the engine running for approx. 5 minutes to activate the compressor. Perform the refrigerating cycle with the refrigerant to discharge the compressor oil remaining on the functional parts into the compressor as much as possible.

2) Stop the engine.

3) Close the valves on the low-/high-pressure sides of the manifold gauge set.

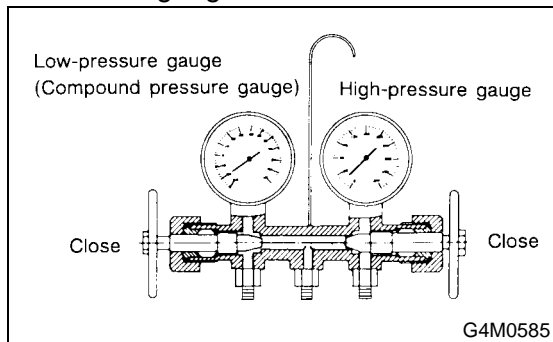

4) Install the low-/high-pressure hoses to the service ports on the low-/high-pressure sides of the vehicle respectively.

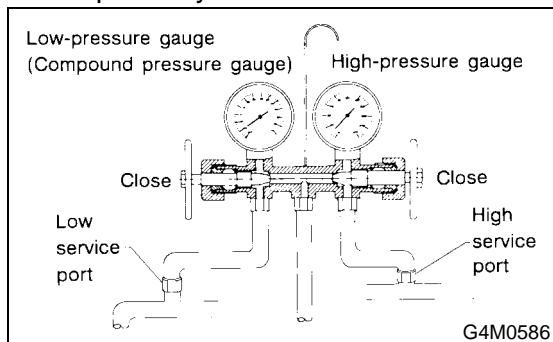

5) Connect the center hose to the refrigerant recovery system.

6) Follow the operation manual to activate the refrigerant recovery system.

# REFRIGERANT CHARGING PROCEDURE

HVAC SYSTEM (HEATER, VENTILATOR AND A/C)

## 4. Refrigerant Charging Procedure

### A: OPERATION

#### CAUTION:

- During operation, be sure to wear safety goggles and protective gloves.
- Before charging the refrigerant, evacuate the system to remove small amounts of moisture remaining in the system.

The moisture in the system can be completely evacuated only under the minimum vacuum level. The minimum vacuum level affects the temperature in the system.

- The list below shows the vacuum values necessary to boil water in various temperature. In addition, the vacuum levels indicated on the gauge are approx. 3.3 kPa (25 mmHg, 0.98 inHg) lower than those measured at 304.8 m (1,000 ft) above sea level.

| Vacuum level required to boil water (at sea level) |                                 |
|--|---------------------------------|
| Temperature  | Vacuum                          |
| 1.7°C (35°F)                                       | 100.9 kPa (757 mmHg, 29.8 inHg) |
| 7.2°C (45°F)                                       | 100.5 kPa (754 mmHg, 29.7 inHg) |
| 12.8°C (55°F)                                      | 99.8 kPa (749 mmHg, 29.5 inHg)  |
| 18.3°C (65°F)                                      | 99.2 kPa (744 mmHg, 29.3 inHg)  |
| 23.9°C (75°F)                                      | 98.5 kPa (739 mmHg, 29.1 inHg)  |
| 29.4°C (85°F)                                      | 97.2 kPa (729 mmHg, 28.7 inHg)  |
| 35°C (95°F)  | 95.8 kPa (719 mmHg, 28.3 inHg)  |

1) Close the valves on low-/high-pressure sides of the manifold gauge.

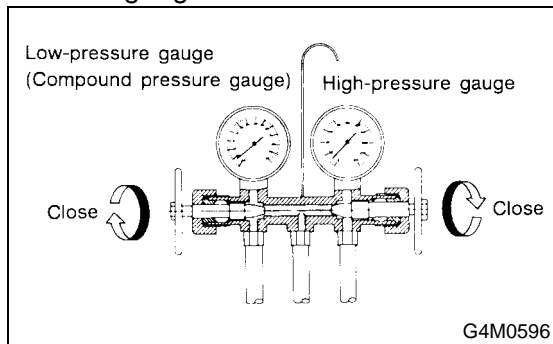

- 2) Install the low-/high-pressure hoses to the corresponding service ports on the vehicle respectively.  
 3) Connect the center hose of the manifold gauge set with the vacuum pump.

4) Carefully open the valves on the low-/high-pressure sides to activate the vacuum pump.

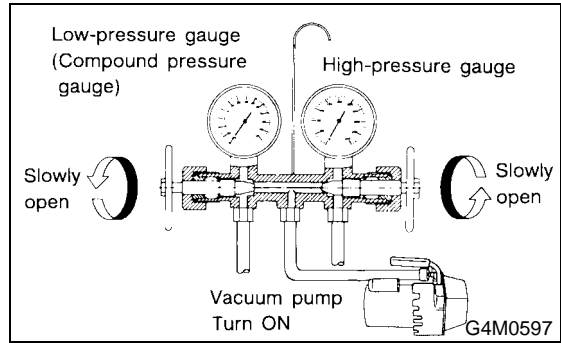

5) After the low-pressure gauge reaches 100.0 kPa (750 mmHg, 29.5 inHg) or higher, evacuate the system for approx. 15 minutes.

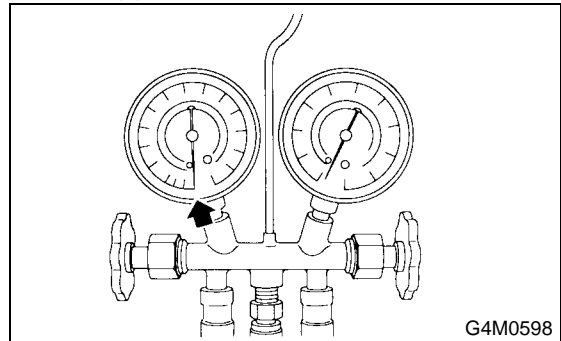

6) After 15 minutes of evacuation, if the reading shows 100.0 kPa (750 mmHg, 29.5 inHg) or higher, close the valves on the both sides to stop the vacuum pump.

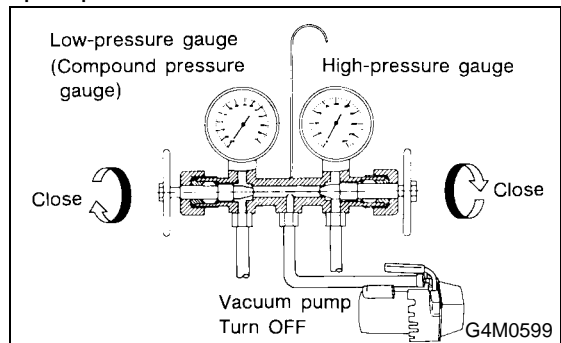

7) Note the low-pressure gauge reading.

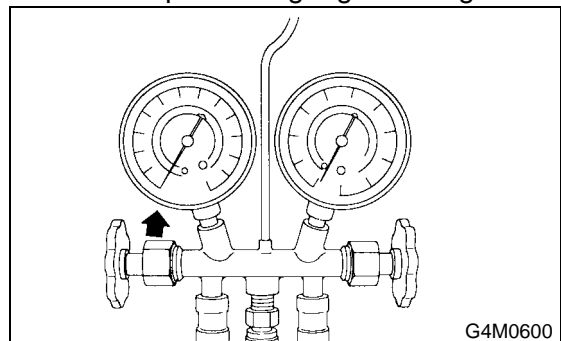

# REFRIGERANT CHARGING PROCEDURE

HVAC SYSTEM (HEATER, VENTILATOR AND A/C)

8) Leave it at least 5 minutes, and then check the low-pressure gauge reading for any changes. When a gauge indicator shows near to zero point, this is a sign of leakage. Check pipe connector points, repair them, make sure there is no leakage by air bleeding.

9) Following the can tap operation manual instructions, install it to the refrigerant can.

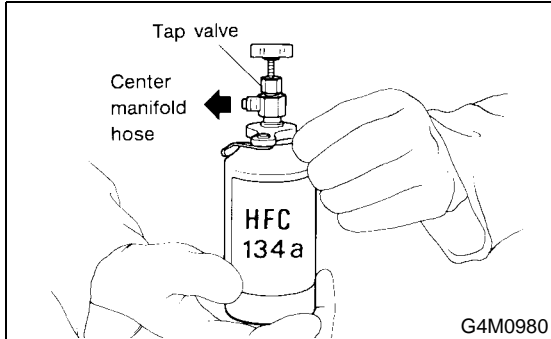

10) Disconnect the center manifold hose from the vacuum pump, and connect the hose to the tap valve.

11) When a 13.6 kg (30 lb) refrigerant container is used, measure the refrigerant amount in use using a weighting scale.

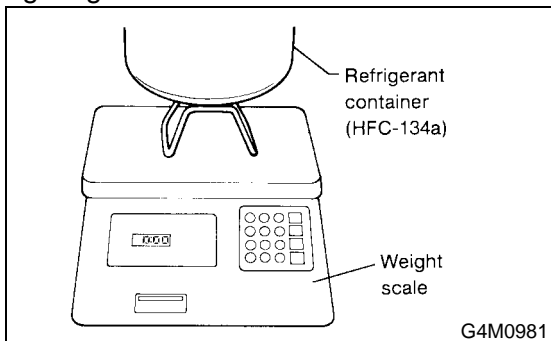

12) Confirm that all the 3 hoses are tightly connected to the manifold gauge set.

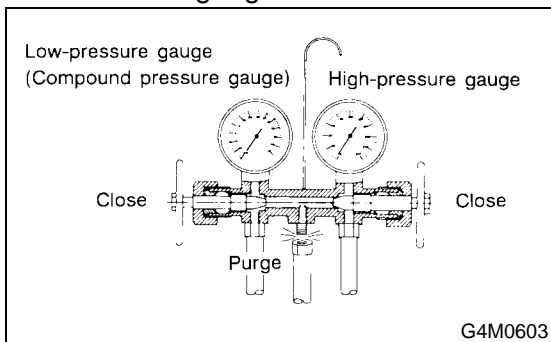

13) Open the valve on the HFC-134a source.

14) Loosen the center hose connection on the manifold gauge set (if applicable, press a purge valve on the manifold gauge set) only for a couple of seconds to allow the air in the center hose to escape by the refrigerant.

15) Carefully open the high-pressure valve with the engine stopping.

## CAUTION:

Do not open the low-pressure valve.

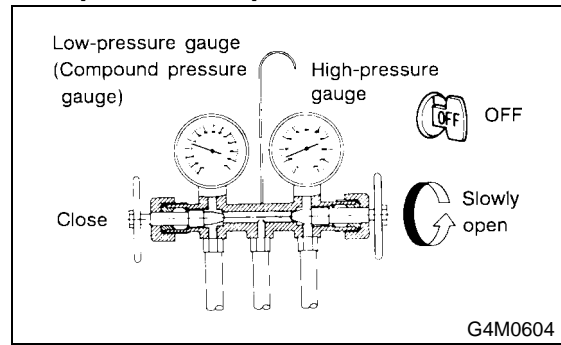

## CAUTION:

Never run the engine during charging from the high-pressure side.

16) Close the high-pressure valve when the low-pressure gauge reaches 98 kPa (1 kg/cm<sup>2</sup>, 14 psi). Using a leak tester, check the system for leaks.

If any leakage is found after the refrigerant recovery is completed, repair the applicable area.

17) After confirming that there are no leaks with the leak test, charge the required amount of refrigerant.

## CAUTION:

Never run the engine during charging from the high-pressure side.

18) Close the high-pressure valve when;

- the readings of low- and high-pressure gauges become almost equal, after the charging speed is reduced,
- the HFC-134a source becomes empty, or
- the system is filled with the gas.

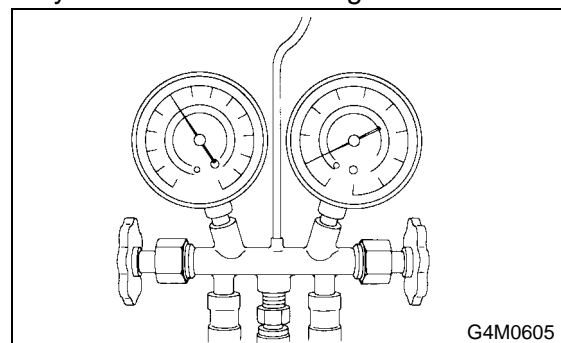

# REFRIGERANT CHARGING PROCEDURE

HVAC SYSTEM (HEATER, VENTILATOR AND A/C)

19) If the HFC-134a source is empty, close the high-pressure valve, close the valve on the can tap, and replace the HFC-134a source with a new one to restart the operation.

27) Disconnect the hose from the service port, and install the service port cap.

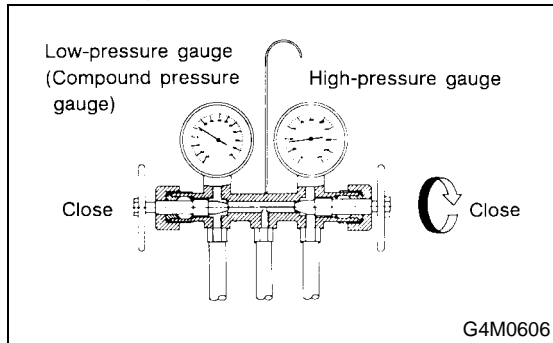

20) Confirm that both the low- and high-pressure valves can be closed. Start the engine with the A/C switch OFF.

21) Quickly repeat ON-OFF cycles a few times to prevent initial compressor damage.

22) Set up the vehicle to the following status:

- A/C switch ON
- Engine running at 1,500 rpm
- Blower speed setting to "HI"
- Temperature setting to "MAX COOL"
- Air inlet setting to "RECIRC"
- Windows open

23) While reading the low-pressure gauge, carefully open the low-pressure valve with the refrigerant source connected and the service hose purged.

**CAUTION:**

**Never open the high-pressure valve with the engine running.**

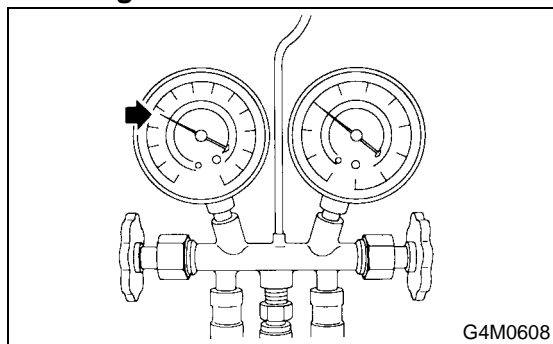

24) Adjust the refrigerant flow to maintain the pressure on the low-pressure side at 276 kPa (2.81 kg/cm<sup>2</sup>, 40 psi) max.

25) After the system is fully charged, close the low-pressure valve.

26) Close the valve on the refrigerant source.

| Refrigerant amount |     |                 |                 |
|--------------------|-----|-----------------|-----------------|
| Refrigerant        |     | Minimum         | Maximum         |
| HFC-134a           | LHD | 0.6 kg (1.3 lb) | 0.7 kg (1.5 lb) |
|                    | RHD | 0.4 kg (0.9 lb) | 0.5 kg (1.1 lb) |

# REFRIGERANT LEAK CHECK

HVAC SYSTEM (HEATER, VENTILATOR AND A/C)

## 5. Refrigerant Leak Check

### A: INSPECTION

1) Operate the A/C system for approx. 10 minutes, and confirm that the high-side pressure shows at least 690 kPa (7.03 kg/cm<sup>2</sup>, 100 psi). Then stop the engine to start the leak test.

2) Starting from the connection between the high-pressure tube and evaporator, check the system for leaks along the high-pressure side through the compressor. The following items must be checked thoroughly.

- Connection between the tube and tube fitting

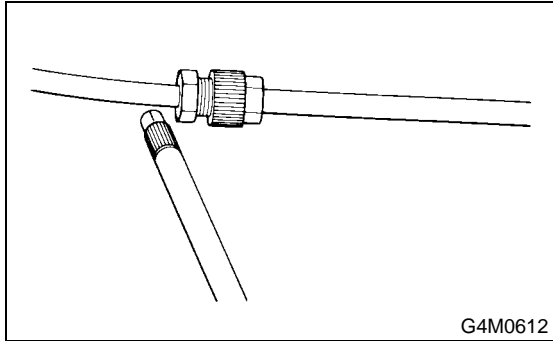

- Connection between 2 parts

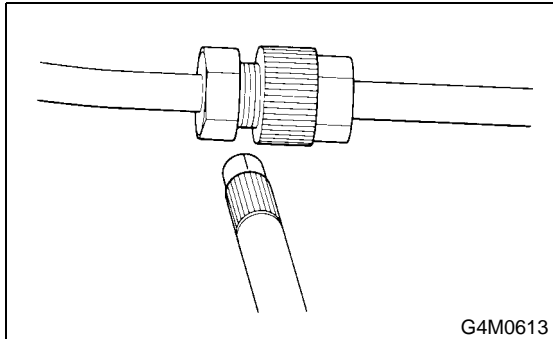

- Connection between the tube and nut

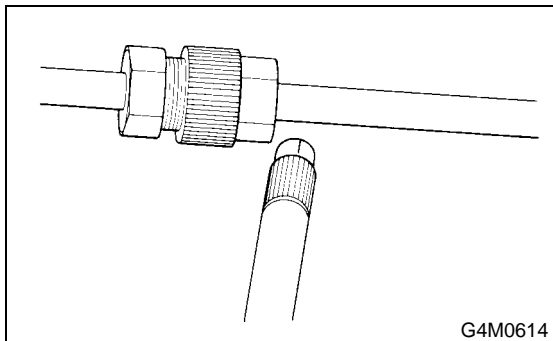

3) Check the joint and seam between the pressure switch (dual switch) and receiver dryer.

4) Check the connections between the condenser and tubes, and welded joints on the condenser.

The leak tester may detect the oil on the condenser fins as a leak.

5) Check the joint between the compressor and hoses.

6) Check the machined area of compressor and other joints on the compressor.

7) Check the thermal limiter (if equipped) on the compressor housing.

8) Check the compressor shaft seal at the area near the center of compressor clutch pulley.

Some shaft seals show a slight amount of leakage about 28 g (1.0 oz) per year. This is not a problem.

9) Starting from the connection between the low-pressure tube and evaporator, check the system for leakage along the high-pressure side through the compressor. The following items must be checked thoroughly.

- Connection between the tube and tube fitting
- Connection between 2 parts
- Connection between the tube and nut

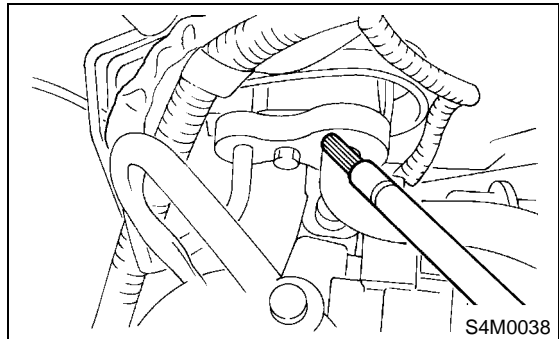

10) Visually check the rubber area of the flexible hose for cracks.

Check the entire length of the flexible hose, especially the connection with the metal hose end.

### CAUTION:

Carefully check the external surface of hoses and tubes at approx. 25 mm (0.98 in) per second.

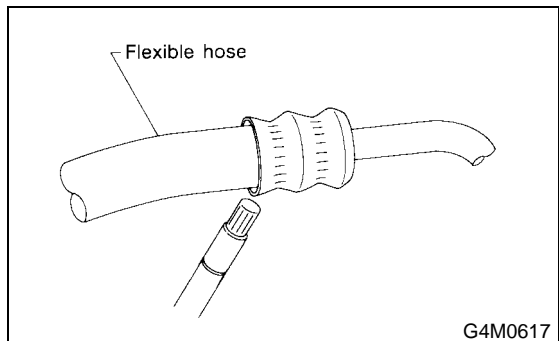

11) Disconnect the drain hose from the evaporator case, and check the hose end for at least 10 seconds.

After the test is finished, reconnect the drain hose.

## REFRIGERANT LEAK CHECK

HVAC SYSTEM (HEATER, VENTILATOR AND A/C)

12) Turn the ignition key to ON position, and run the blower at high speed for 1 minute. Stop the blower to check the ventilation grill on the instrument panel. While moving the tester closer to the grill, run the blower for 1 or 2 seconds, then stop it. Check the grill at that point for at least 10 seconds.

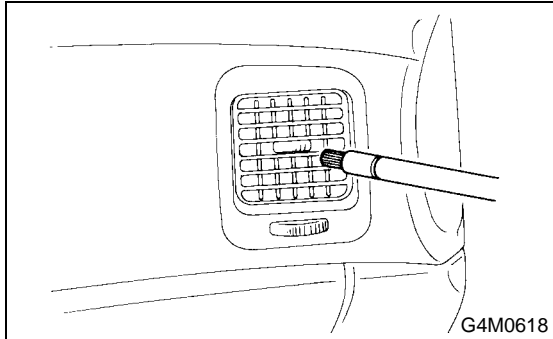

13) Check the valve in the service port.  
14) Visually check the rubber seal in the service port cap.

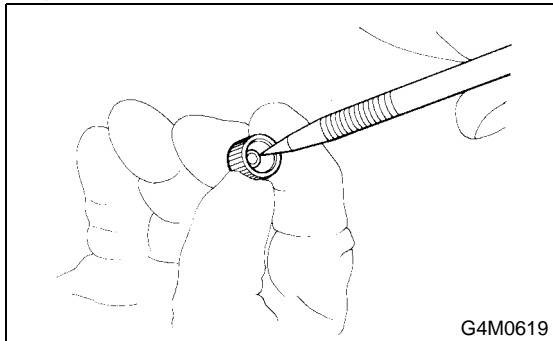

# COMPRESSOR OIL

HVAC SYSTEM (HEATER, VENTILATOR AND A/C)

---

## 6. Compressor Oil

### A: OPERATION

NOTE:

Before making repairs, conduct the oil return operation to return the compressor oil in circulation with the refrigerant to the compressor.

- 1) Increase engine rpm to 1,500.
- 2) Turn ON the A/C switch.
- 3) Turn the temperature control switch to MAX COOL.
- 4) Put in RECIRC position.
- 5) Turn the blower control switch to HI.
- 6) Leave in this condition for 10 minutes.

### B: REPLACEMENT

NOTE:

- If a component is replaced, add an appropriate amount of compressor oil.
- When replacing the compressor, the new compressor will already have the specified amount of oil in it. Install the new compressor after removing the same amount of oil that is remaining in the compressor removed.

| Replacement parts | Amount of oil replenishment           |
|-------------------|---------------------------------------|
| Evaporator        | 114 m ℓ (3.9 US fl oz, 4.0 Imp fl oz) |
| Condenser         | 7 m ℓ (0.24 US fl oz, 0.25 Imp fl oz) |
| Hose              | 1 m ℓ (0.03 US fl oz, 0.04 Imp fl oz) |



# BLOWER MOTOR UNIT ASSEMBLY

HVAC SYSTEM (HEATER, VENTILATOR AND A/C)

## 7. Blower Motor Unit Assembly

### A: REMOVAL

- 1) Disconnect ground cable from battery.
- 2) Remove glove box. <Ref. to EI-22, REMOVAL, Glove Box.>
- 3) Loosen nut to remove support beam stay.

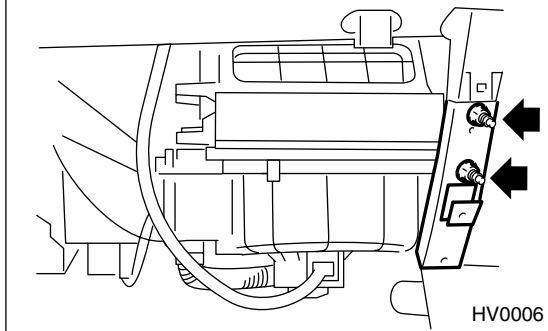

- 4) Disconnect motor connector.

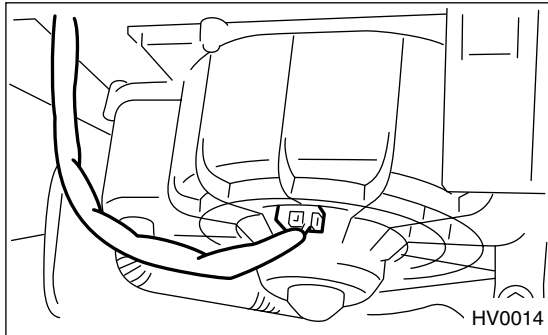

- 5) Disconnect resistor connector.

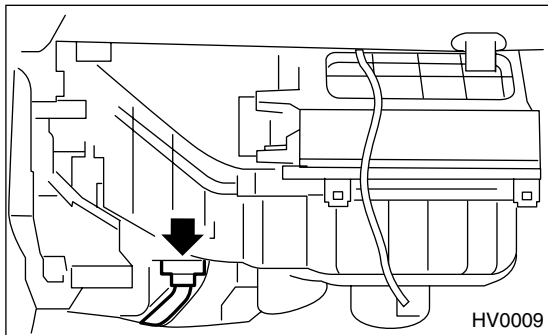

- 6) Loosen bolt and nut to remove blower motor unit assembly.

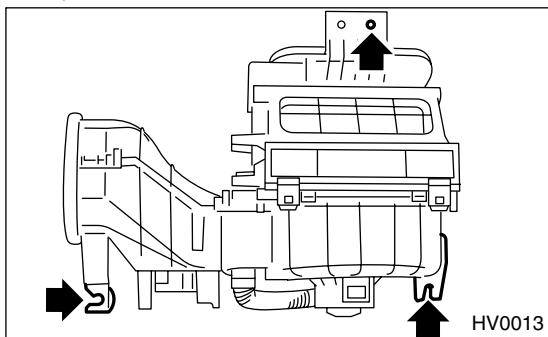

### B: INSTALLATION

Install in the reverse order of removal.

### C: INSPECTION

Connect motor connector terminal 1 from the battery to the positive (+) lead and terminal 2 to the negative (-) lead. Make sure the motor runs smoothly.

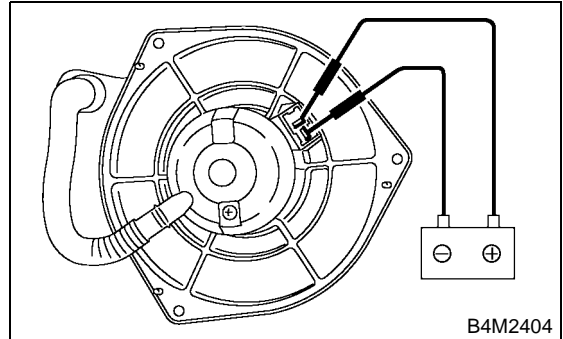

## POWER TRANSISTOR (HEATER BLOWER RESISTOR)

HVAC SYSTEM (HEATER, VENTILATOR AND A/C)

---

### 8. Power Transistor (Heater Blower Resistor)

#### A: REMOVAL

- 1) Remove glove box. <Ref. to EI-22, REMOVAL, Glove Box.>
- 2) Disconnect power transistor connector.
- 3) Loosen 2 screws to remove power transistor.

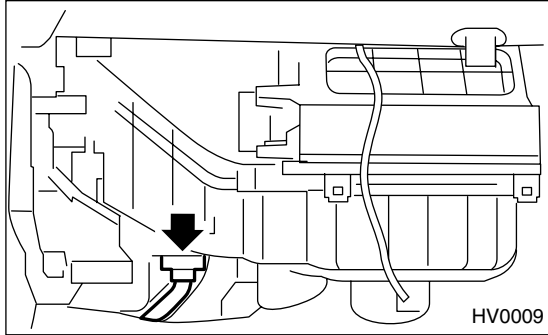

#### B: INSTALLATION

Install in the reverse order of removal.

# HEATER CORE

HVAC SYSTEM (HEATER, VENTILATOR AND A/C)

## 9. Heater Core

### A: REMOVAL

- 1) Remove heater and cooling unit. <Ref. to AC-29, REMOVAL, Heater and Cooling Unit.>
- 2) Loosen screws to remove heater core cover.

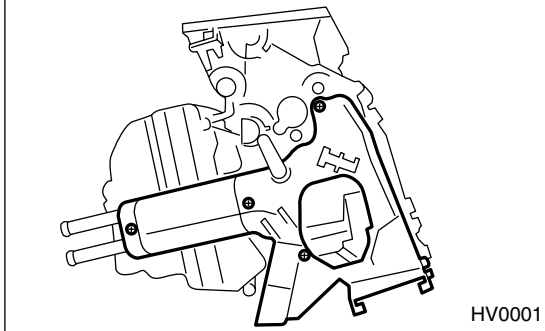

- 3) Remove heater core.

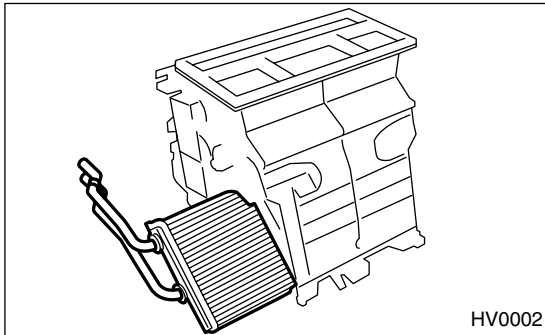

### B: INSTALLATION

Install in the reverse order of removal.

## CONTROL UNIT

HVAC SYSTEM (HEATER, VENTILATOR AND A/C)

---

### 10. Control Unit

#### A: REMOVAL

- 1) Disconnect Battery ground cable.
- 2) Remove center console panel.
- 3) Disconnect connector and aspirator hose (A).

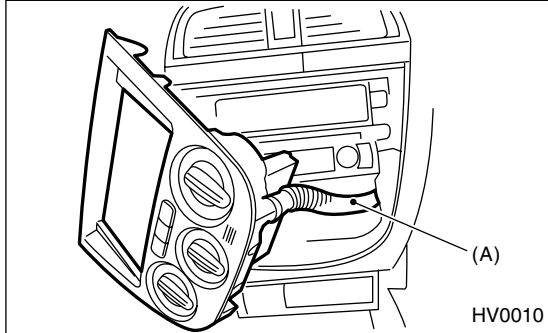

#### B: INSTALLATION

Install in the reverse order of removal.

# COMPRESSOR

HVAC SYSTEM (HEATER, VENTILATOR AND A/C)

## 11. Compressor

### A: INSPECTION

#### 1. MAGNETIC CLUTCH CLEARANCE

1) Check the clearance of the entire circumference around the drive plate and pulley.

**Standard:**

$0.45 \pm 0.15 \text{ mm}$  ( $0.0177 \pm 0.0059 \text{ in}$ )

#### 2. MAGNETIC CLUTCH OPERATION

1) Disconnect the compressor connector.  
2) Connect the battery positive terminal to the NO.3 terminal of the compressor connector.

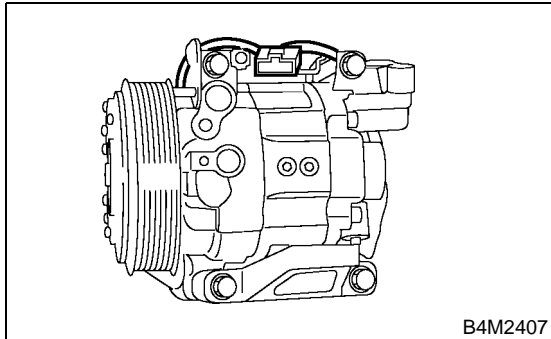

3) Make sure the magnet clutch engages.  
If NG, replace the compressor.

### B: REMOVAL

1) Perform compressor oil return operation. <Ref. to AC-22, OPERATION, Compressor Oil.>  
2) Turn A/C switch OFF and stop the engine.  
3) Using refrigerant recovery system, discharge refrigerant. <Ref. to AC-16, OPERATION, Refrigerant Recovery Procedure.>  
4) Disconnect ground cable from battery.  
5) Remove V-belt. <Ref. to ME(SOHC)-42, REMOVAL, V-belt.> or <Ref. to ME(DOHC TURBO)-43, REMOVAL, V-belt.>  
6) Remove generator. <Ref. to SC-12, REMOVAL, Generator.>  
7) Remove low-pressure hose and high-pressure hose.

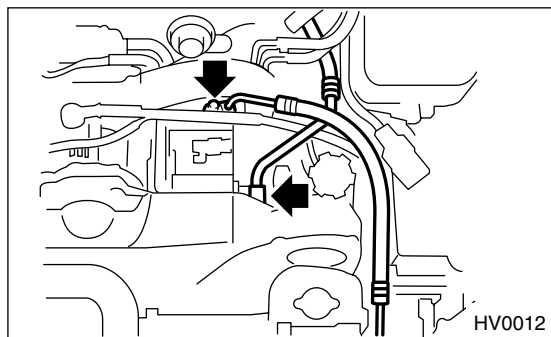

8) Disconnect compressor harness from body harness.

9) Loosen bolts to remove compressor bracket.

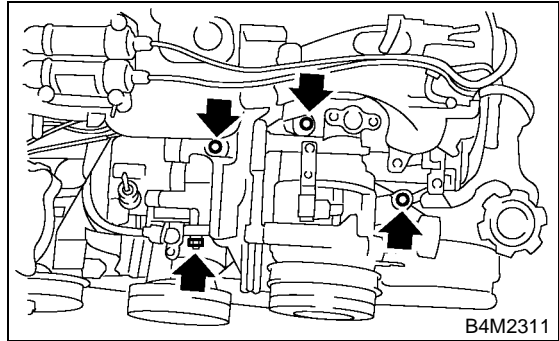

10) Remove bolts and then separate compressor and bracket.

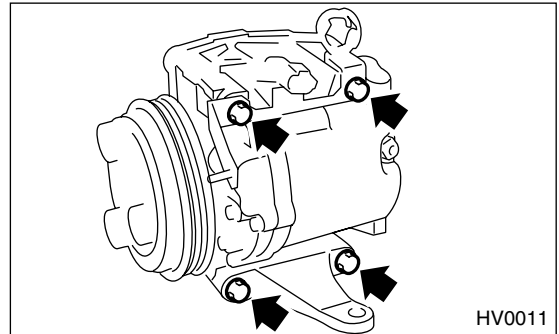

### C: INSTALLATION

1) Install in the reverse order of removal.  
2) Replace O-rings on low-/high-pressure hoses with new ones, then apply compressor oil.  
3) When replacing compressor, adjust amount of compressor oil. <Ref. to AC-22, OPERATION, Compressor Oil.>  
4) Charge refrigerant. <Ref. to AC-17, OPERATION, Refrigerant Charging Procedure.>

# CONDENSER

HVAC SYSTEM (HEATER, VENTILATOR AND A/C)

## 12. Condenser

### A: REMOVAL

- 1) Using refrigerant recovery system, discharge refrigerant. <Ref. to AC-16, OPERATION, Refrigerant Recovery Procedure.>
- 2) Disconnect ground cable from battery.
- 3) Disconnect pressure hose and pipe from condenser.

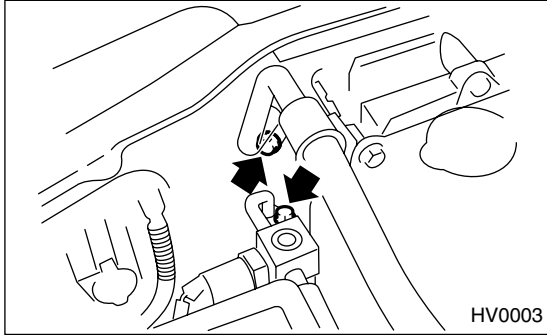

- 4) Remove radiator bracket (A).

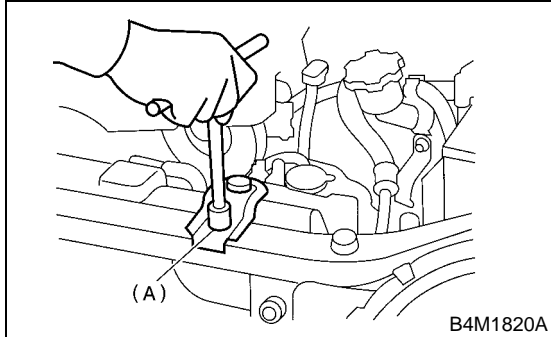

- 5) Remove two bolts. While lifting condenser, pull it out through space between the radiator and the radiator panel.

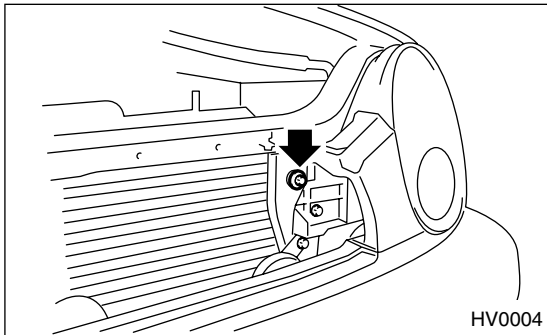

### CAUTION:

Be careful not to damage condenser fins. If a damaged fin is found, repair it using a thin screwdriver.

If condenser is replaced, add appropriate amount of compressor oil to the compressor. <Ref. to AC-22, REPLACEMENT, Compressor Oil.>

### B: INSTALLATION

- 1) Install in the reverse order of removal.

### CAUTION:

Replace O-rings on hoses or pipes with new ones, and then apply compressor oil. Confirm that lower guide of condenser has been fitted into holes on radiator panel.

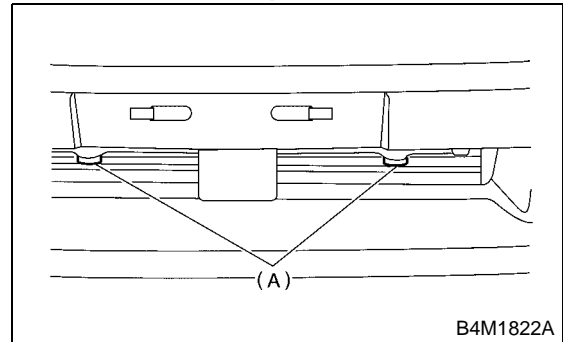

- 2) Charge refrigerant. <Ref. to AC-17, OPERATION, Refrigerant Charging Procedure.>

### C: INSPECTION

- 1) Confirm that no dust or insects are found on the condenser fins. Air-blow or flush fins with water as needed.
- 2) Confirm that no oil leaks from condenser. If a failure is found, replace condenser with a new one.

## 13.Heater and Cooling Unit

### A: REMOVAL

- 1) Disconnect ground cable from battery.
- 2) Using refrigerant recovery system, discharge refrigerant. <Ref. to AC-16, OPERATION, Refrigerant Recovery Procedure.>
- 3) Drain LLC from radiator.
- 4) Removes bolt securing expansion valve and pipe in engine compartment. Release heater hose clamps in engine compartment to remove the hoses.

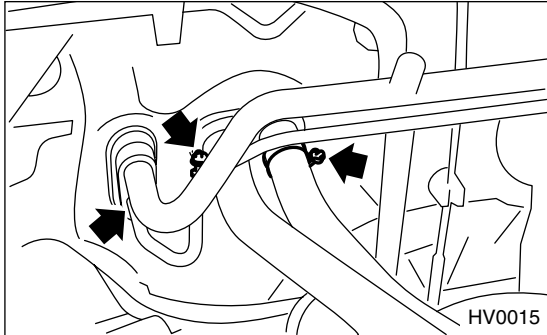

- 5) Remove instrument panel. <Ref. to EI-25, REMOVAL, Instrument Panel Assembly.>
- 6) Remove support beam.
- 7) Remove blower motor unit assembly. <Ref. to AC-23, REMOVAL, Blower Motor Unit Assembly.>
- 8) Disconnect servo motor connectors.
- 9) Loosen bolt and nuts to remove heater and cooling unit.

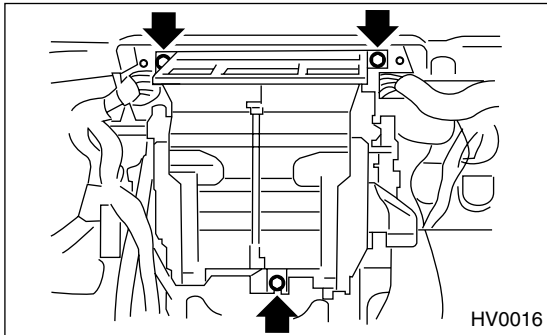

### B: INSTALLATION

- 1) Install in the reverse order of removal.
- 2) Charge refrigerant. <Ref. to AC-17, OPERATION, Refrigerant Charging Procedure.>

# EVAPORATOR

HVAC SYSTEM (HEATER, VENTILATOR AND A/C)

## 14. Evaporator

### A: REMOVAL

- 1) Remove heater and cooling unit. <Ref. to AC-29, REMOVAL, Heater and Cooling Unit.>
- 2) Loosen screws and clip to remove evaporator cover.

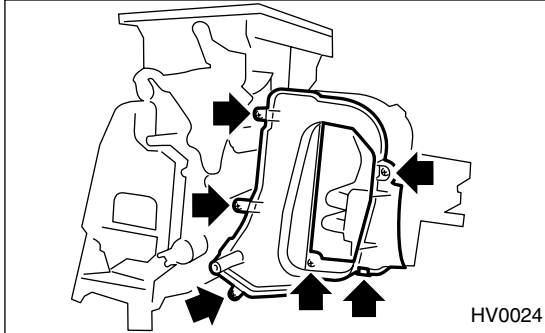

- 3) Remove evaporator.

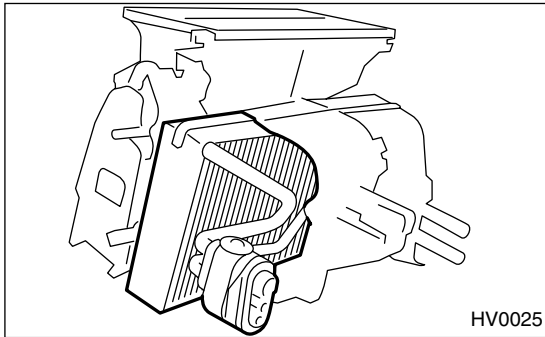

- 4) Loosen two bolts to remove expansion valve.

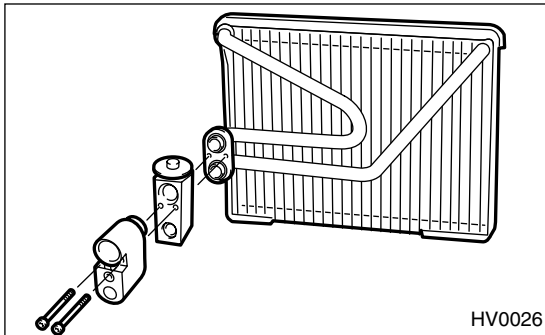

### CAUTION:

If evaporator is replaced, add appropriate amount of compressor oil to evaporator. <Ref. to AC-22, REPLACEMENT, Compressor Oil.>

### B: INSTALLATION

Install in the reverse order of removal.



# HOSE AND TUBE

HVAC SYSTEM (HEATER, VENTILATOR AND A/C)

## 15.Hose and Tube

### A: REMOVAL

#### CAUTION:

- When disconnecting/connecting hoses, do not apply excessive force them. Confirm that no torsion and excessive tension exist after installing.
  - Seal the disconnected hose with a plug or vinyl tape to prevent contamination from entering.
- 1) Disconnect ground cable from battery.
  - 2) Using refrigerant recovery system, discharge refrigerant. <Ref. to AC-16, OPERATION, Refrigerant Recovery Procedure.>
  - 3) Remove evaporator unit mounting bolt (A).
  - 4) Remove low-pressure hose attaching bolts (B).
  - 5) Disconnect low-pressure hose from evaporator unit.
  - 6) Disconnect low-pressure hose from compressor.
  - 7) Remove low-pressure hose from the vehicle.
  - 8) Remove high-pressure hose attaching bolts (C).
  - 9) Disconnect high-pressure hose from compressor.
  - 10) Disconnect high-pressure hose from condenser.
  - 11) Remove high-pressure hose from the vehicle.
  - 12) Remove high-pressure tube attaching bolt (D).
  - 13) Remove high-pressure tube from the vehicle.

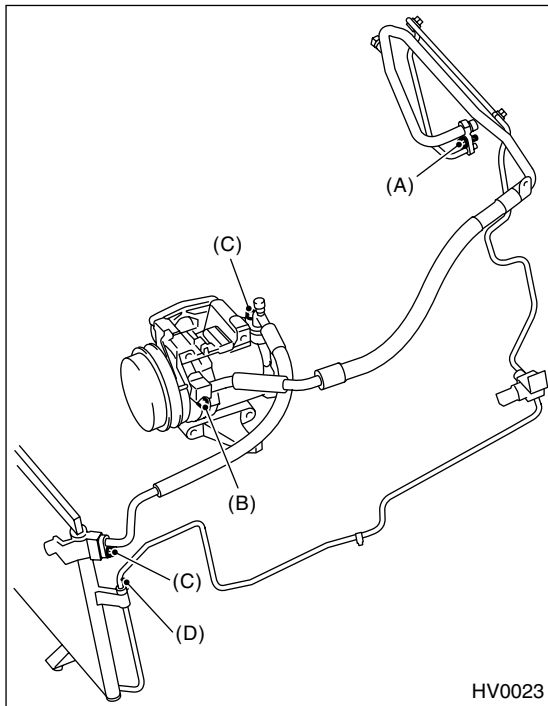

### B: INSTALLATION

#### CAUTION:

When disconnecting/connecting hoses, do not apply an excessive force them. Confirm that no torsion and excessive tension exist after installing. Seal the disconnected hose with a plug or vinyl tape to prevent contamination from entering.

- 1) Install in the reverse order of removal.
- 2) Charge refrigerant. <Ref. to AC-17, OPERATION, Refrigerant Charging Procedure.>

### C: INSPECTION

#### NOTE:

If cracking, damage, or swelling is found on a hose, replace it with a new one.

# RELAY AND FUSE

HVAC SYSTEM (HEATER, VENTILATOR AND A/C)

## 16. Relay and Fuse

### A: LOCATION

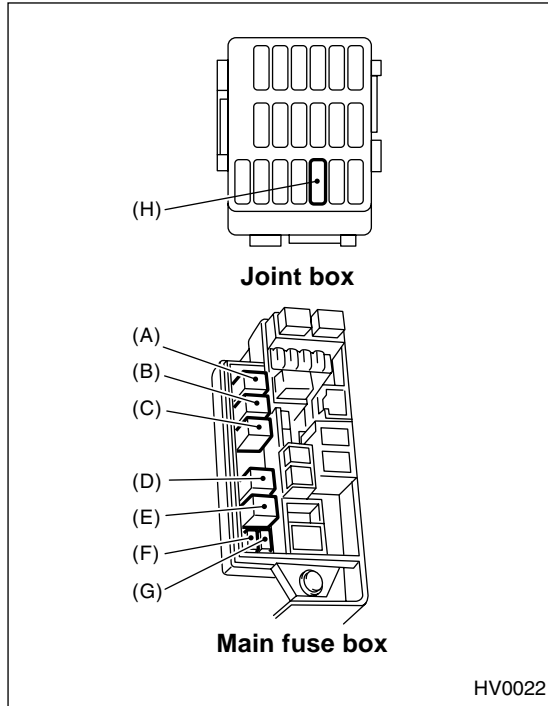

|                  |   |
|------------------|---|
| Main Fan Relay 1 | A |
| Main Fan Relay 2 | B |
| Sub Fan Relay 1  | C |
| Sub Fan Relay 2  | E |
| A/C Relay        | D |
| Main Fan Fuse    | F |
| Sub Fan Fuse     | G |
| A/C Fuse         | H |

### B: INSPECTION

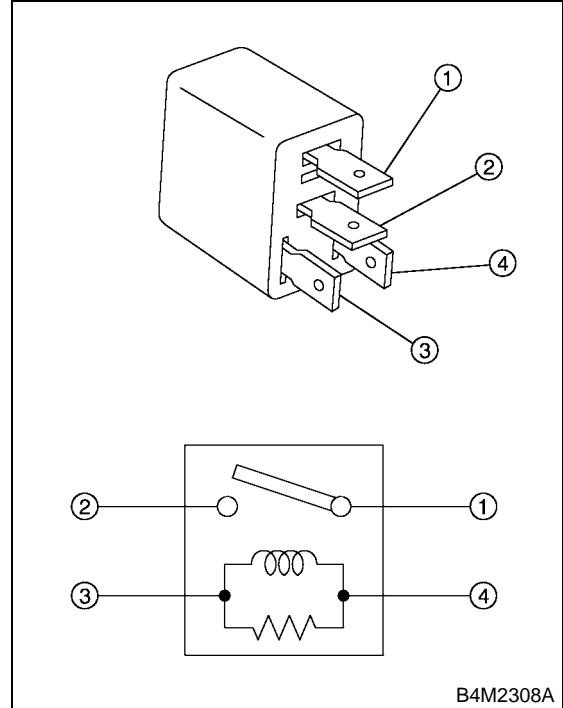

(3) — (4): Continuity exists.

(1) — (2): No continuity

While applying battery voltage to the cable between (3) and (4), check continuity between (1) and (2).

If no continuity exists, replace the relay with a new one.

# PRESSURE SWITCH (DUAL SWITCH)

HVAC SYSTEM (HEATER, VENTILATOR AND A/C)

## 17. Pressure Switch (Dual Switch)

### A: INSPECTION

1) Connect the manifold gauge to the service valve on the high-pressure side.

2) Remove the pressure switch harness connector. Using a circuit tester, inspect the ON-OFF operation of the pressure switch.

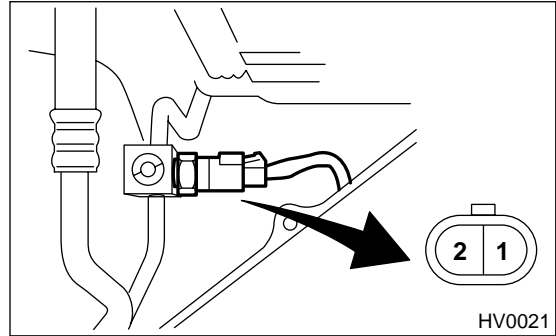

|                              | Tester connection | Operation  | Specified condition<br>kPa (kg/cm <sup>2</sup> , psi)   |
|------------------------------|-------------------|------------|---|
| High and low pressure switch | 1 — 2             | Turns OFF. | Increasing to<br>2,800±100 (29±1, 406±15)   |
|                              |                   |            | Decreasing to<br>278±29 (2.83±0.3, 40.3±4.2)  |
|                              |                   | Turns ON.  | Increasing to<br>287 <sup>+39</sup> / <sub>-25</sub> (2.9 <sup>+0.4</sup> / <sub>-0.25</sub> , 42 <sup>+5.7</sup> / <sub>-3.6</sub> ) |
|                              |                   |            | Decreasing to<br>2,200±200 (22.4±2, 319±29)   |

## AMBIENT SENSOR (AUTO A/C)

HVAC SYSTEM (HEATER, VENTILATOR AND A/C)

---

### 18. Ambient Sensor (Auto A/C)

#### A: REMOVAL

- 1) Open front hood.
- 2) Disconnect ground cable from battery.
- 3) Disconnect ambient sensor connector.
- 4) Remove ambient sensor from radiator lower panel.

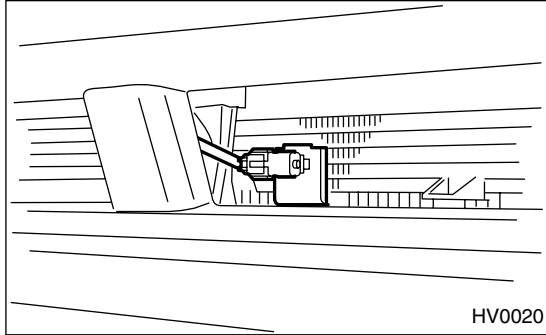

#### B: INSTALLATION

Install in the reverse order of removal.

#### C: INSPECTION

<Ref. to AC-36, AMBIENT SENSOR, Diagnostic Procedure for Sensors.>

## SUN-LOAD SENSOR (AUTO A/C)

HVAC SYSTEM (HEATER, VENTILATOR AND A/C)

### 19.Sun-load Sensor (Auto A/C)

#### A: REMOVAL

- 1) Disconnect ground cable from battery.
- 2) Remove front defroster grille.
- 3) Disconnect sunload sensor connector (A).

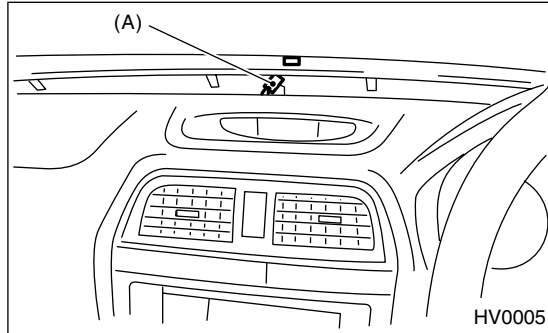

#### CAUTION:

Be careful not to damage sensors and interior trims when removing them.

#### B: INSTALLATION

Install in the reverse order of removal.

#### C: INSPECTION

<Ref. to AC-43, SUNLOAD SENSOR, Diagnostic Procedure for Sensors.>

# AIR VENT GRILLE

HVAC SYSTEM (HEATER, VENTILATOR AND A/C)

---

## 20. Air Vent Grille

### A: REMOVAL

#### 1. CENTER GRILLE

- 1) Disconnect ground cable from battery.
- 2) Remove center console panel (A).
- 3) Loosen two screws to remove center air vent grille (B).

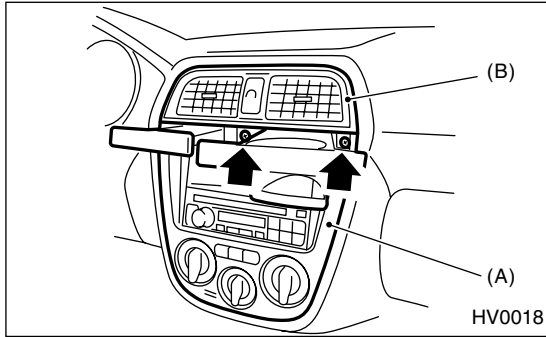

#### 2. SIDE GRILLE

- 1) Disconnect ground cable from battery.
- 2) Remove heater vent duct. <Ref. to AC-38, REMOVAL, Heater Vent Duct.>
- 3) Loosen screws to remove side air vent grille.

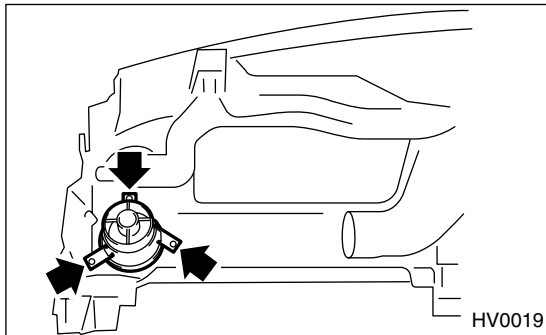

### B: INSTALLATION

Install in the reverse order of removal.

### C: INSPECTION

The direction and amount of air should be adjusted smoothly.

The adjustment should be kept in each position.

# HEATER DUCT

HVAC SYSTEM (HEATER, VENTILATOR AND A/C)

## 21.Heater Duct

### A: REMOVAL

- 1) Remove heater unit. <Ref. to AC-29, Removal.>
- 2) Remove front seat. <Ref. to SE-6, REMOVAL, Front Seat.>
- 3) Remove front side sill cover.
- 4) Pull off floor mat to remove heater duct.

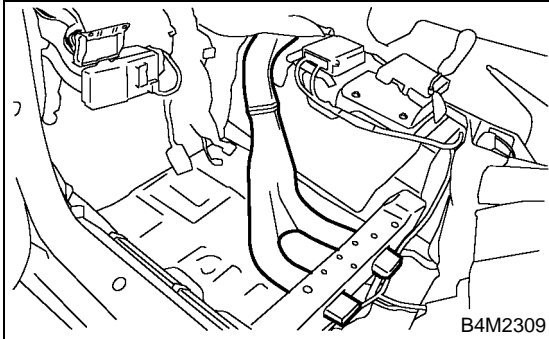

### B: INSTALLATION

Install in the reverse order of removal.

# HEATER VENT DUCT

HVAC SYSTEM (HEATER, VENTILATOR AND A/C)

---

## 22.Heater Vent Duct

### A: REMOVAL

- 1) Remove instrument panel. <Ref. to EI-25, REMOVAL, Instrument Panel Assembly.>
- 2) Remove screws.
- 3) Remove heater vent duct.

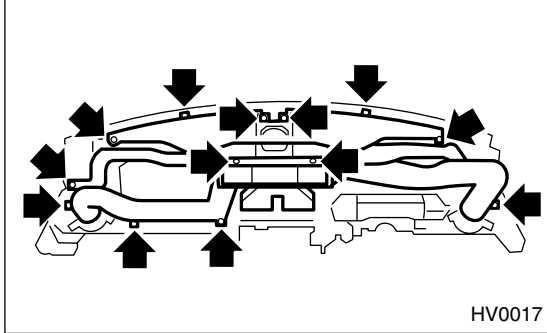

### B: INSTALLATION

Install in the reverse order of removal.



# GENERAL DIAGNOSTICS

HVAC SYSTEM (HEATER, VENTILATOR AND A/C)

## 23. General Diagnostics

### A: INSPECTION

| Symptom  |                         | Repair order           |
|--|-------------------------|------------------------|
| Blower motor                                   | Doesn't move.           | Fuse                   |
|  |                         | Blower motor relay     |
|  |                         | Blower motor           |
|  |                         | Blower motor resistor  |
|  |                         | Blower switch          |
|  |                         | Wire harness           |
|  | Strange noise.          | Blower motor           |
| Compressor                                     | Doesn't move.           | Refrigerant            |
|  |                         | Fuse                   |
|  |                         | Air conditioning relay |
|  |                         | Magnet clutch          |
|  |                         | Compressor             |
|  |                         | Pressure switch        |
|  |                         | A/C switch             |
|  |                         | Blower switch          |
|  |                         | Wire harness           |
|  | Strange noise           | V-Belt                 |
|  |                         | Magnet clutch          |
|  |                         | Compressor             |
|  |                         |                        |
| Cold air not emitted.                          | Refrigerant             |                        |
|  | V-Belt                  |                        |
|  | Magnet clutch           |                        |
|  | Compressor              |                        |
|  | Pressure switch         |                        |
|  | A/C switch              |                        |
|  | Blower switch           |                        |
|  | Wire harness            |                        |
|  | Heater duct             |                        |
|  | Heater vent duct        |                        |
|  | Warm air not emitted.   | Engine coolant         |
| Blower switch                                  |                         |                        |
| Heater core                                    |                         |                        |
| Temperature of air from vents does not change. | Engine coolant          |                        |
|  | Mode actuator           |                        |
|  | Wire harness            |                        |
| Unable to switch blow vents.                   | Mode actuator           |                        |
|  | Air flow switch         |                        |
|  | Wire harness            |                        |
| Unable to switch suction vents.                | Air inlet select switch |                        |
|  | FRESH/RECIRC actuator   |                        |
|  | Wire harness            |                        |

# GENERAL DIAGNOSTICS

HVAC SYSTEM (HEATER, VENTILATOR AND A/C)

---