

BODY SECTION

This service manual has been prepared to provide SUBARU service personnel with the necessary information and data for the correct maintenance and repair of SUBARU vehicles.

This manual includes the procedures for maintenance, disassembling, reassembling, inspection and adjustment of components and diagnostics for guidance of experienced mechanics.

Please peruse and utilize this manual fully to ensure complete repair work for satisfying our customers by keeping their vehicle in optimum condition. When replacement of parts during repair work is needed, be sure to use SUBARU genuine parts.

All information, illustration and specifications contained in this manual are based on the latest product information available at the time of publication approval.

**HVAC SYSTEM
(HEATER, VENTILATOR AND A/C)** AC

**HVAC SYSTEM (AUTO A/C)
(DIAGNOSTICS)** AC

AIRBAG SYSTEM AB

AIRBAG SYSTEM (DIAGNOSTICS) AB

SEAT BELT SYSTEM SB

LIGHTING SYSTEM LI

WIPER AND WASHER SYSTEMS WW

ENTERTAINMENT ET

COMMUNICATION SYSTEM COM

GLASS/WINDOWS/MIRRORS GW

BODY STRUCTURE BS

INSTRUMENTATION/DRIVER INFO IDI

SEATS SE

SECURITY AND LOCKS SL

IMMOBILIZER (DIAGNOSTICS) IM

**SUNROOF/T-TOP/CONVERTIBLE TOP
(SUNROOF)** SR

EXTERIOR/INTERIOR TRIM EI

BODY SECTION

EXTERIOR BODY PANELS

EB

CRUISE CONTROL SYSTEM

CC

**CRUISE CONTROL SYSTEM
(DIAGNOSTICS)**

CC

GLASS/WINDOWS/MIRRORS

GW

	Page
1. General Description	2
2. Power Window System	9
3. Rear Window Defogger System	19
4. Remote Control Mirror System	23
5. Front Door Glass	27
6. Front Regulator and Motor Assembly	31
7. Rear Door Glass	32
8. Rear Regulator and Motor Assembly	34
9. Windshield Glass	35
10. Rear Gate Glass	38
11. Rear Quarter Glass	39
12. Rear Window Glass	40
13. Roof Window Glass	41
14. Inner Rearview Mirror	42
15. Power Window Control Switch	43
16. Rear Window Defogger	45
17. Outer Mirror Assembly	46
18. Outer Mirror	48
19. Remote Control Mirror Switch	49

GENERAL DESCRIPTION

GLASS/WINDOWS/MIRRORS

1. General Description

A: COMPONENT

1. FIXED GLASS (SEDAN)

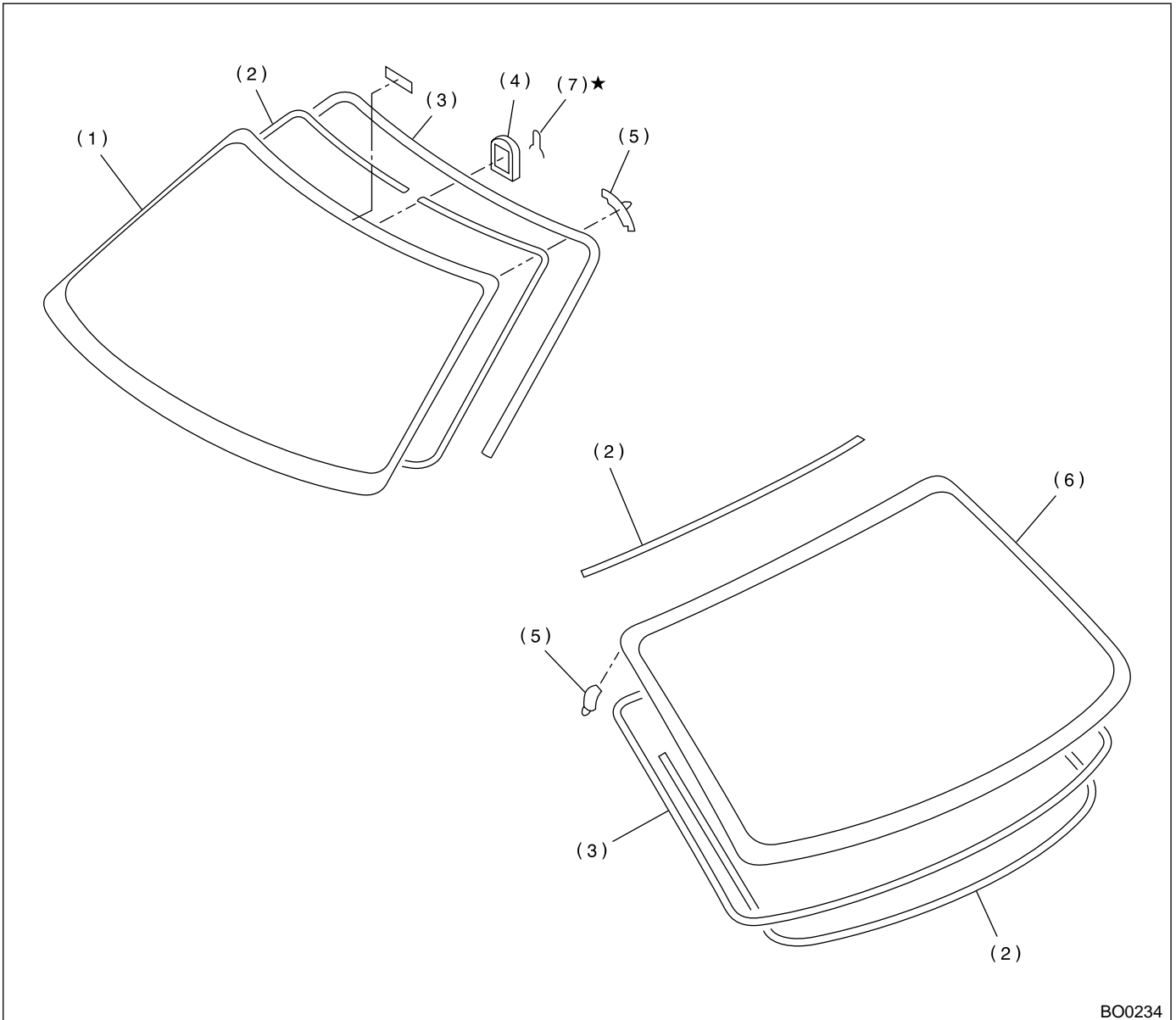

(1) Windshield glass

(2) Dam rubber

(3) Molding

(4) Rearview mirror mount

(5) Locate pin

(6) Rear window glass

(7) Spring

GENERAL DESCRIPTION

GLASS/WINDOWS/MIRRORS

2. FIXED GLASS (WAGON)

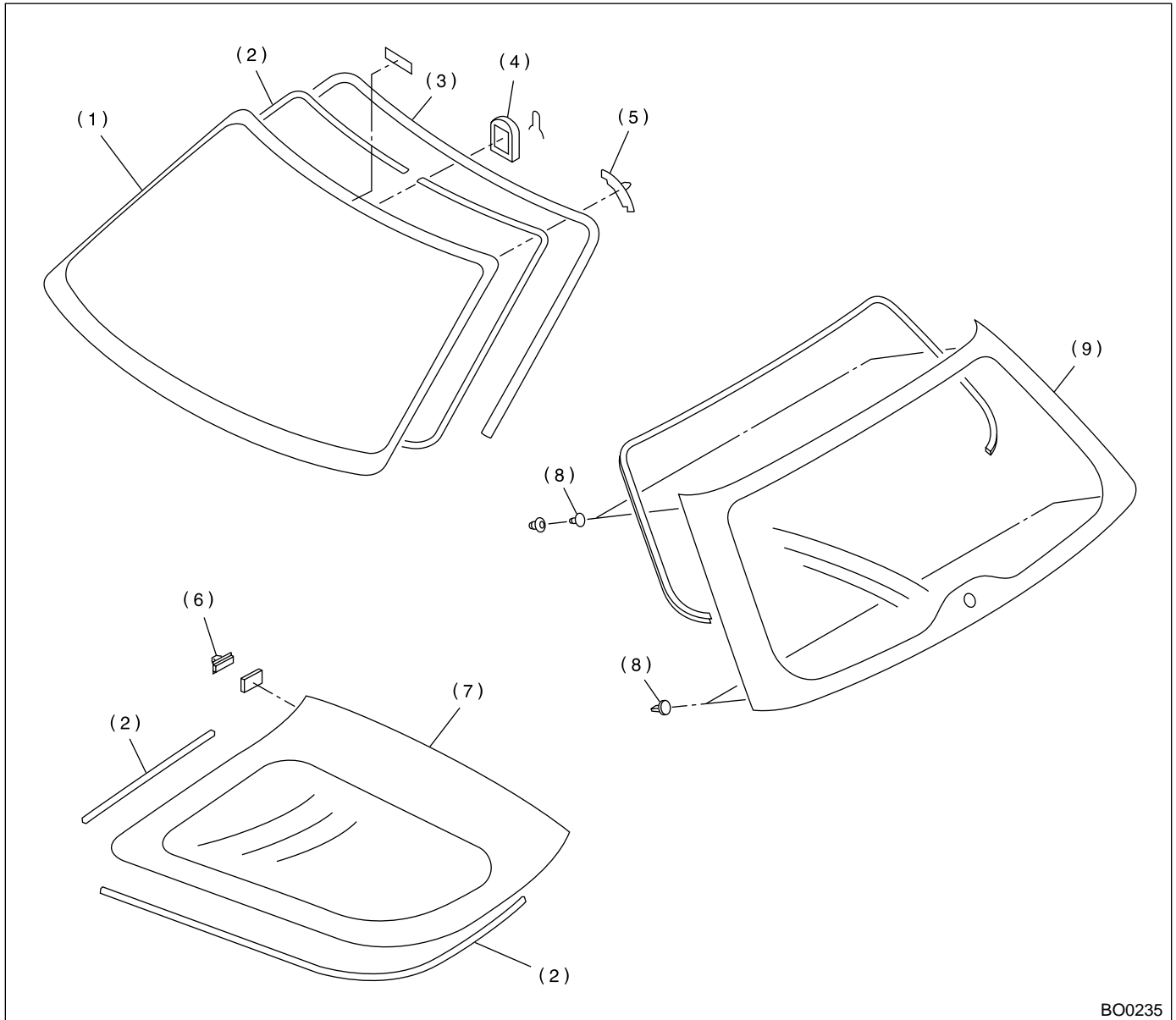

BO0235

- (1) Windshield glass
- (2) Dam rubber
- (3) Molding

- (4) Rearview mirror mount
- (5) Locate pin
- (6) Fastener

- (7) Rear quarter glass
- (8) Locate pin
- (9) Glass

GENERAL DESCRIPTION

GLASS/WINDOWS/MIRRORS

3. FRONT DOOR GLASS

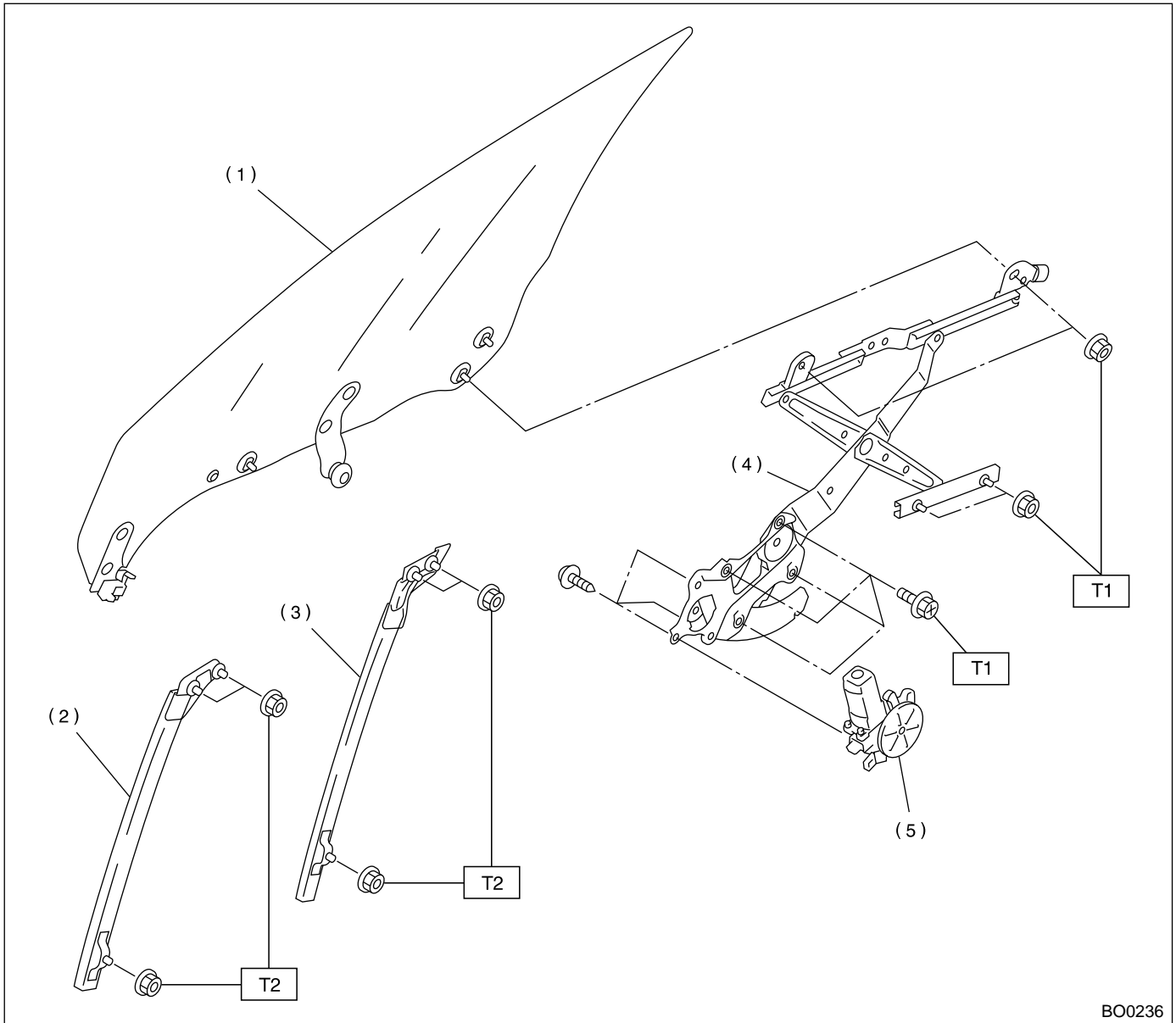

- (1) Glass
- (2) Door sash (Front)
- (3) Door sash (Rear)
- (4) Regulator ASSY

- (5) Motor ASSY

Tightening torque: N·m (kgf·m, ft·lb)

T1: 7.35 (0.75, 5.4)

T2: 14 (1.4, 10.1)

4. REAR DOOR GLASS

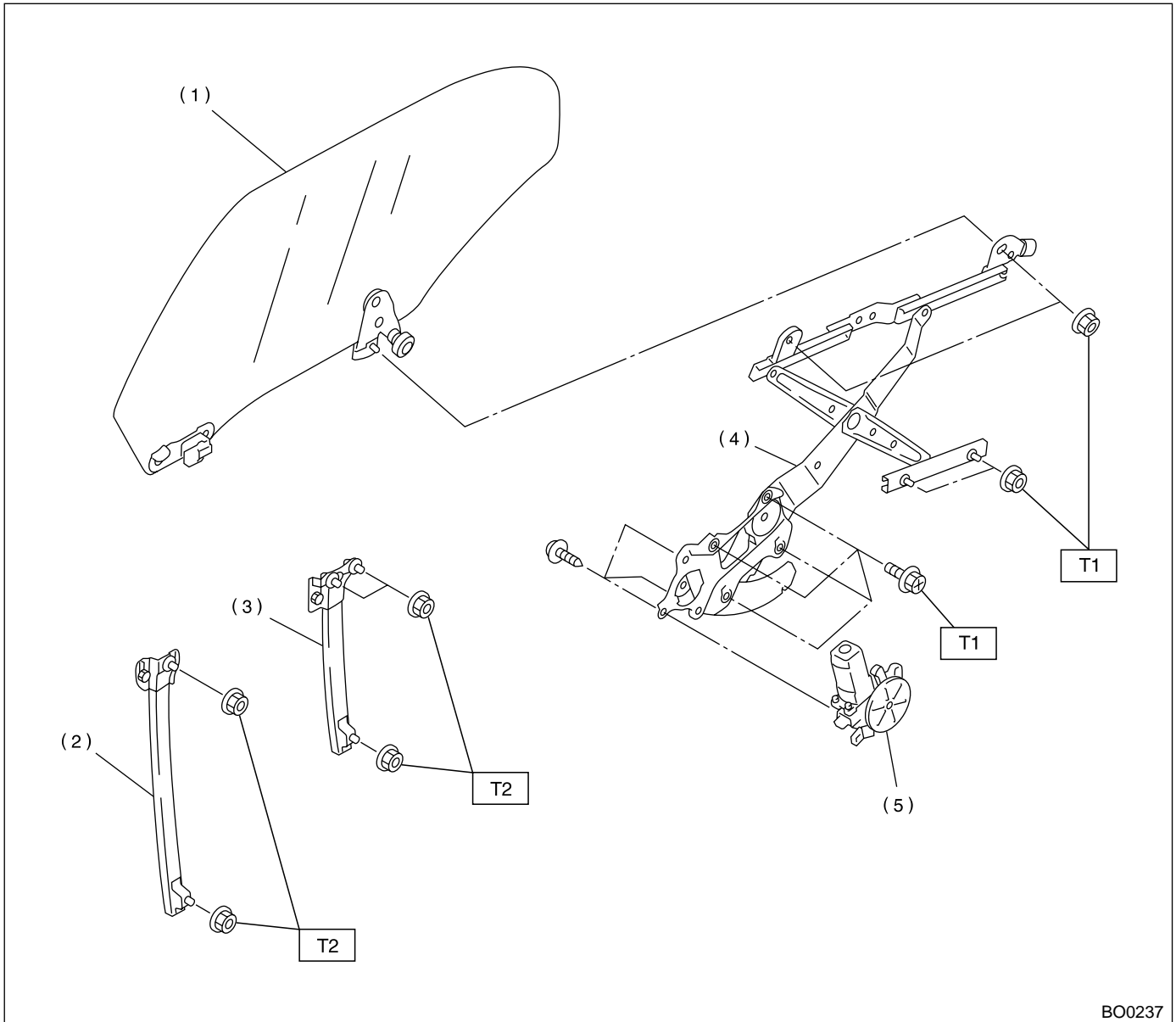

BO0237

- (1) Glass
- (2) Door sash (Front)
- (3) Door sash (Rear)
- (4) Regulator ASSY
- (5) Motor ASSY

Tightening torque: N·m (kgf·m, ft·lb)

T1: 7.35 (0.75, 5.4)

T2: 14 (1.4, 10.1)

GENERAL DESCRIPTION

GLASS/WINDOWS/MIRRORS

5. MIRRORS

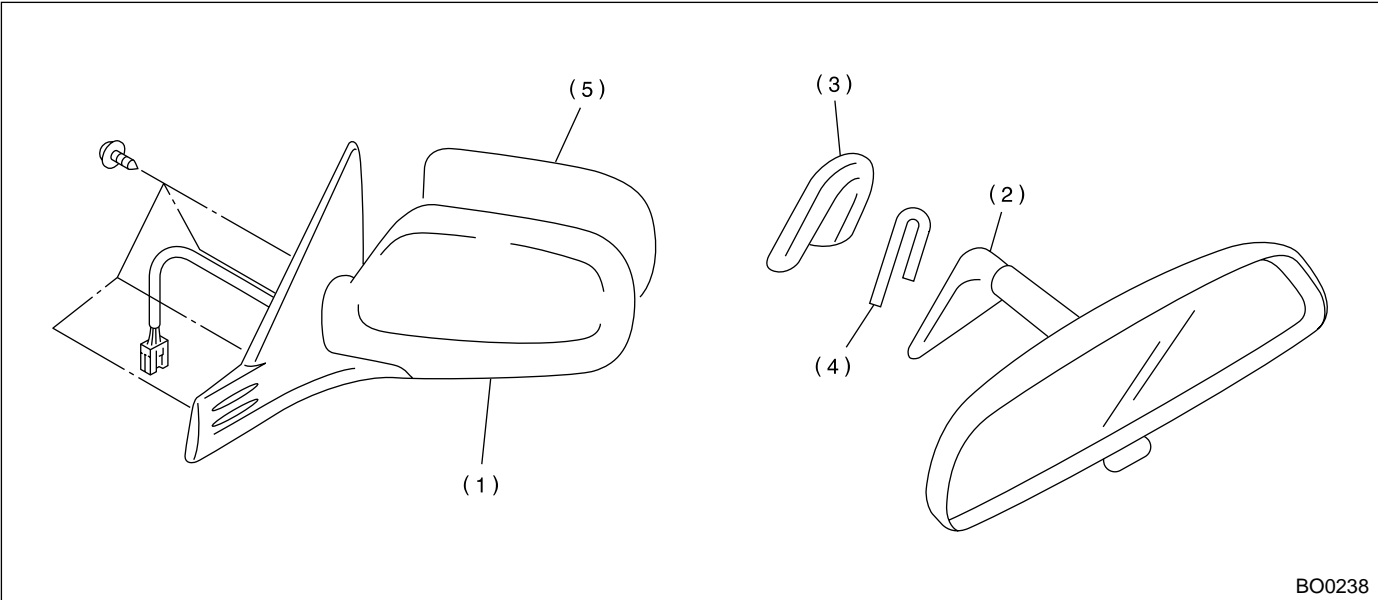

- (1) Outer mirror
- (2) Inner rearview mirror

- (3) Mount
- (4) Spring

- (5) Mirror

B: CAUTION

- When electrical connectors are disconnected, always conduct an operational check after connecting them again.
- Avoid impact and damage to the glass.

GENERAL DESCRIPTION

GLASS/WINDOWS/MIRRORS

C: PREPARATION TOOL

TOOL NAME	REMARKS
Circuit Tester	Used for checking voltage and continuity.
Piano Wire	Used for window glass removal.
Windshield Knife	Used for window glass removal.

2. Power Window System

A: SCHEMATIC

POWER WINDOW SYSTEM

GLASS/WINDOWS/MIRRORS

1. POWER WINDOW LHD MODEL

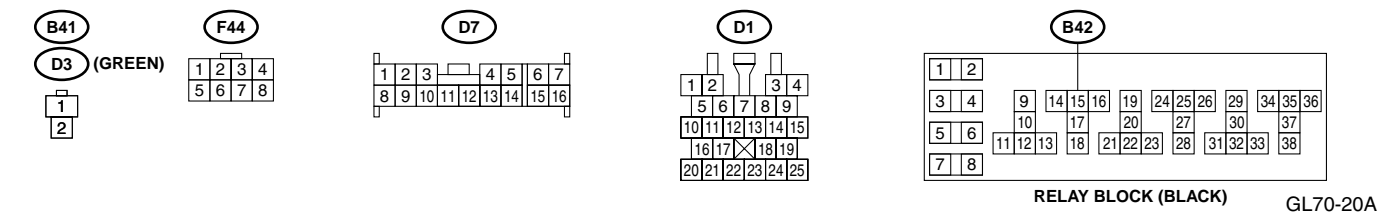
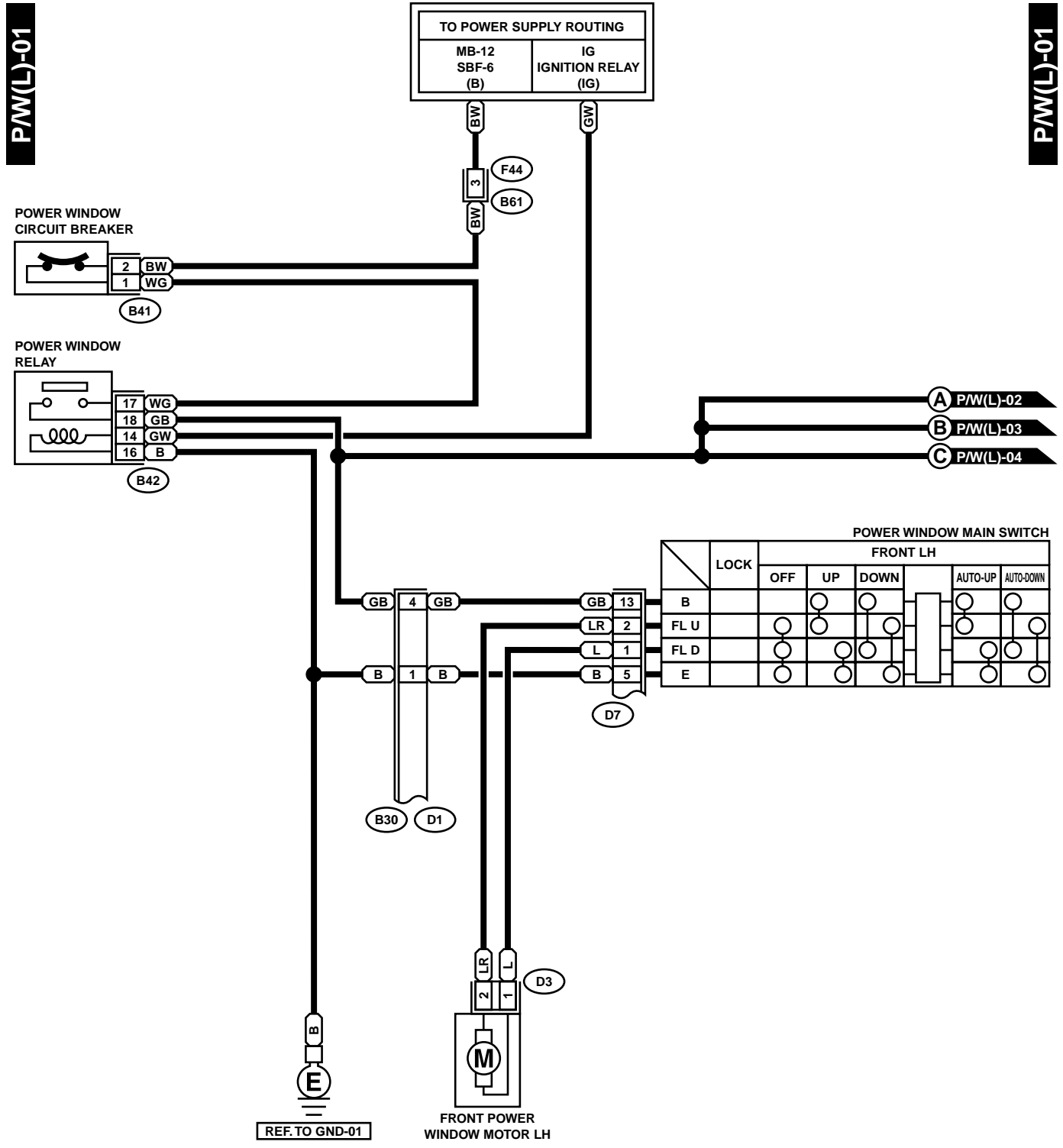

POWER WINDOW SYSTEM

GLASS/WINDOWS/MIRRORS

P/W(L)-02

P/W(L)-02

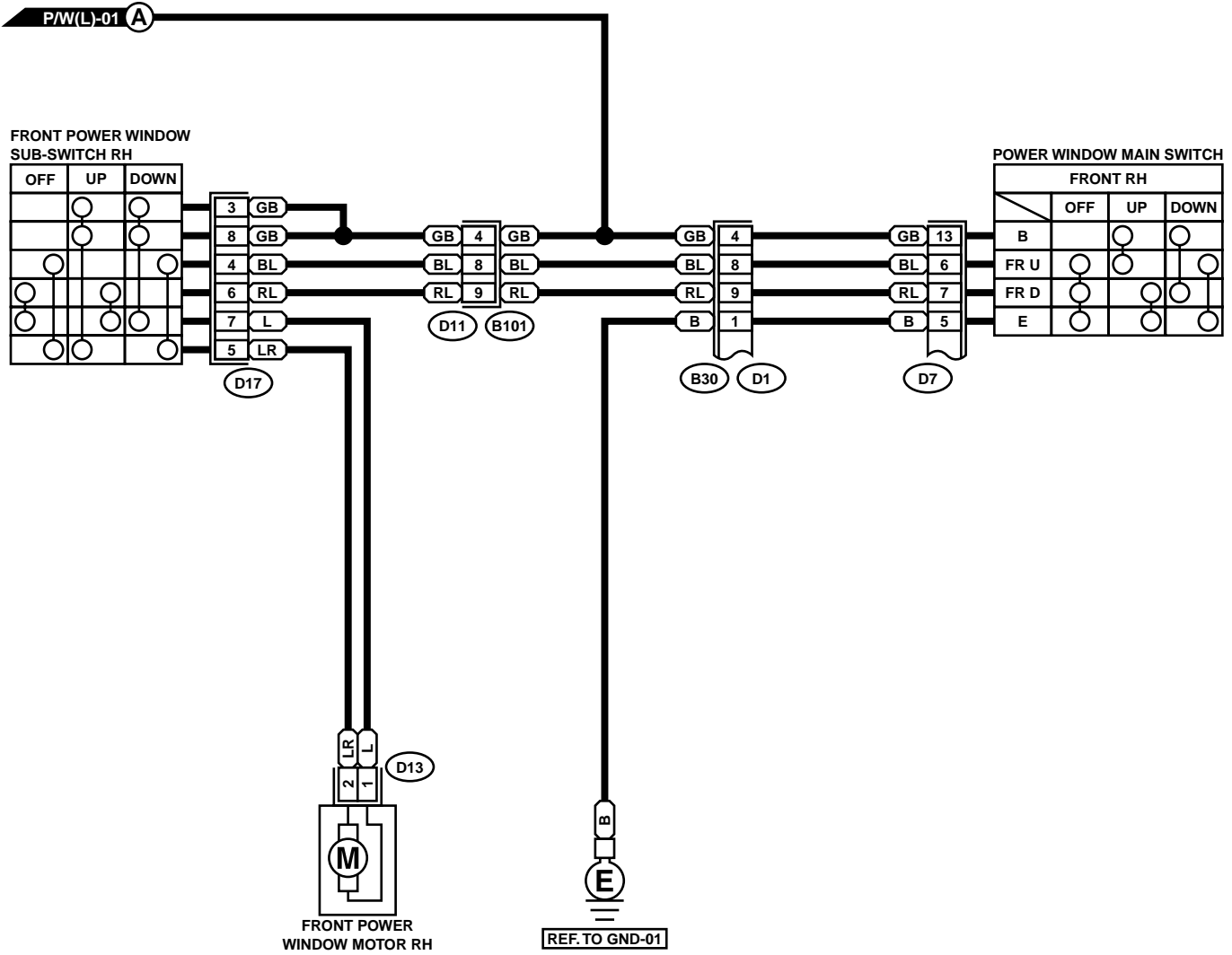

D13 (GREEN)



D17

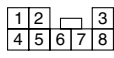

D7

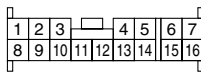

D1

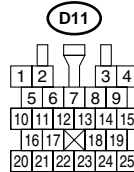

GL70-20B

POWER WINDOW SYSTEM

GLASS/WINDOWS/MIRRORS

P/W(L)-03

P/W(L)-03

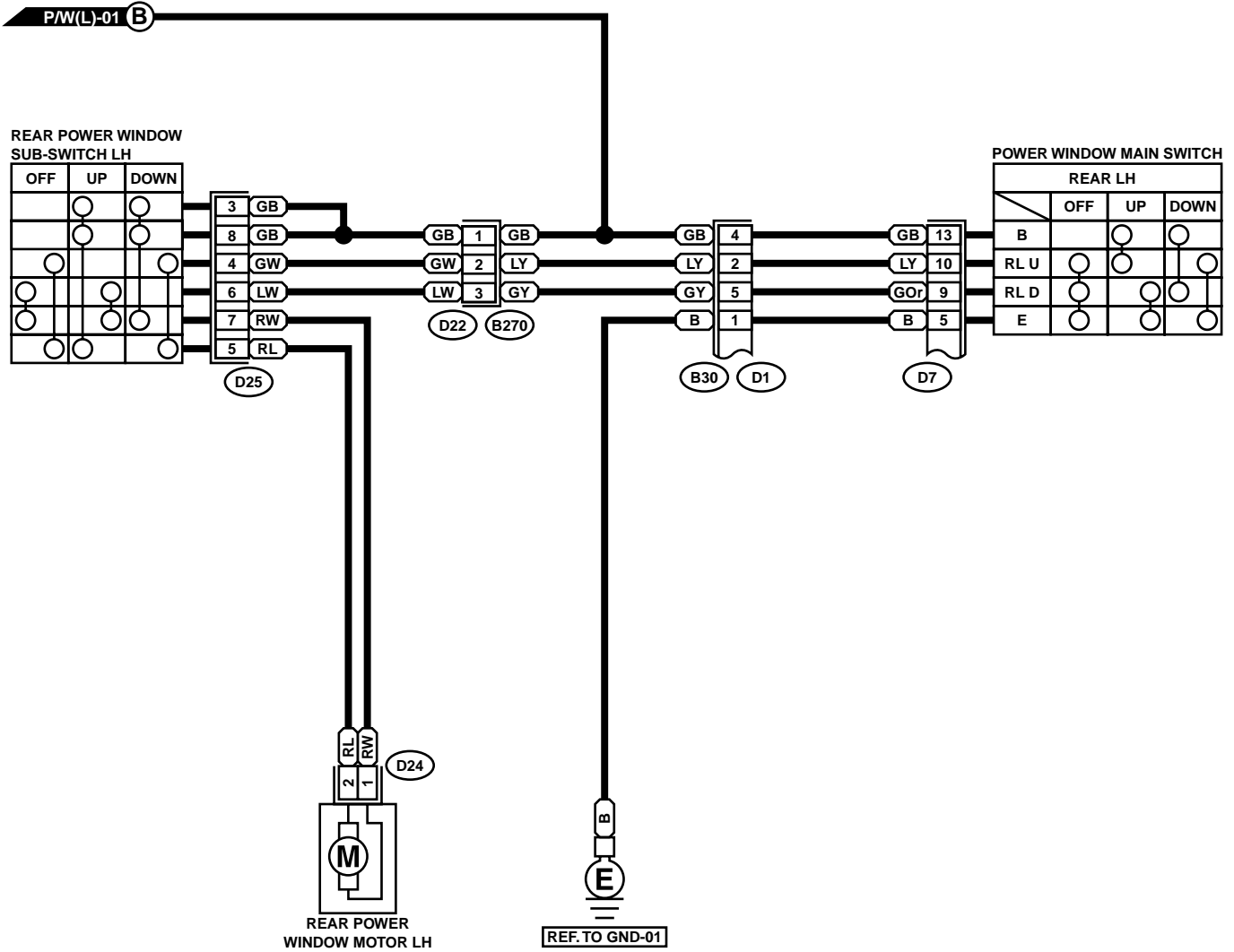

D24 (GREEN)



D22



D25

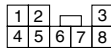

D7

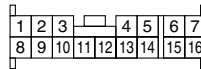

D1

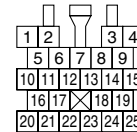

GL70-20C

POWER WINDOW SYSTEM

GLASS/WINDOWS/MIRRORS

P/W(L)-04

P/W(L)-04

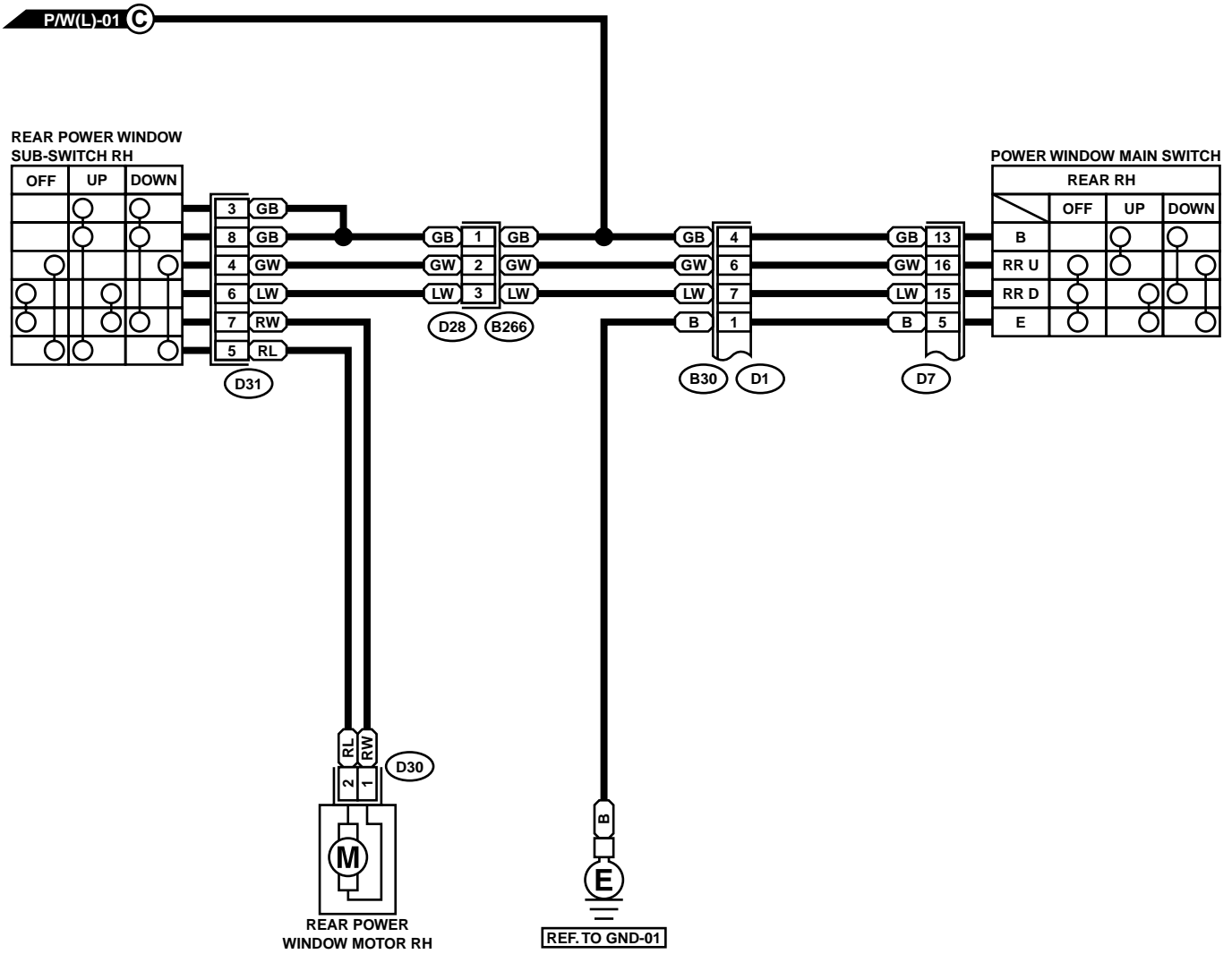

D30 (GREEN)



D28



D31

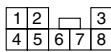

D7

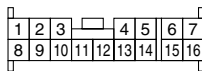

D1

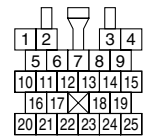

GL70-20D

POWER WINDOW SYSTEM

GLASS/WINDOWS/MIRRORS

2. POWER WINDOW RHD MODEL

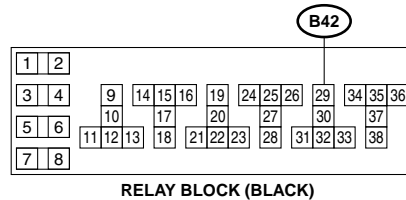
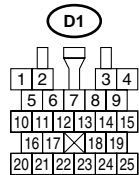
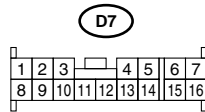
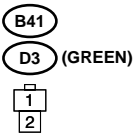
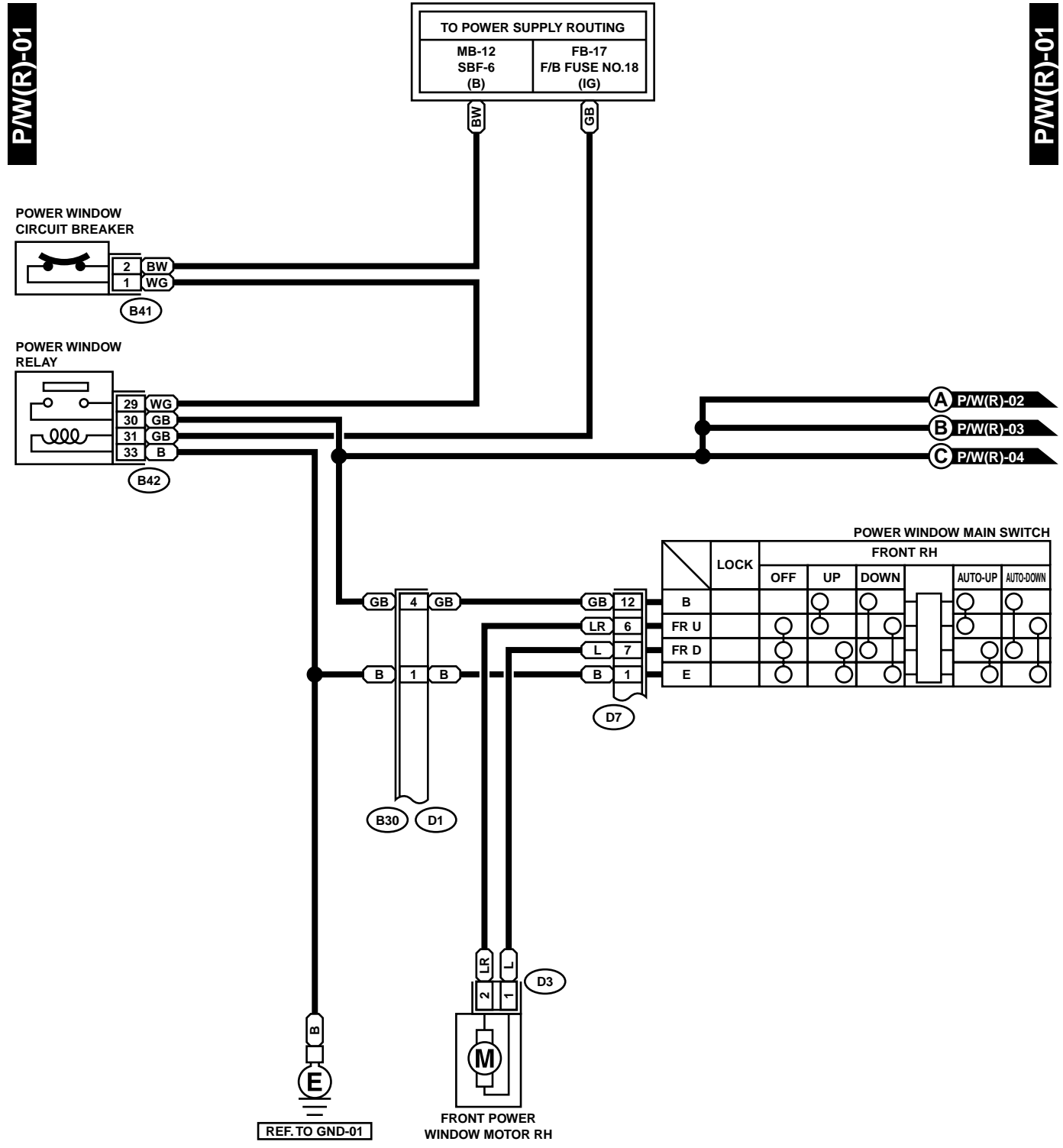

GR70-20A

POWER WINDOW SYSTEM

GLASS/WINDOWS/MIRRORS

P/W(R)-02

P/W(R)-02

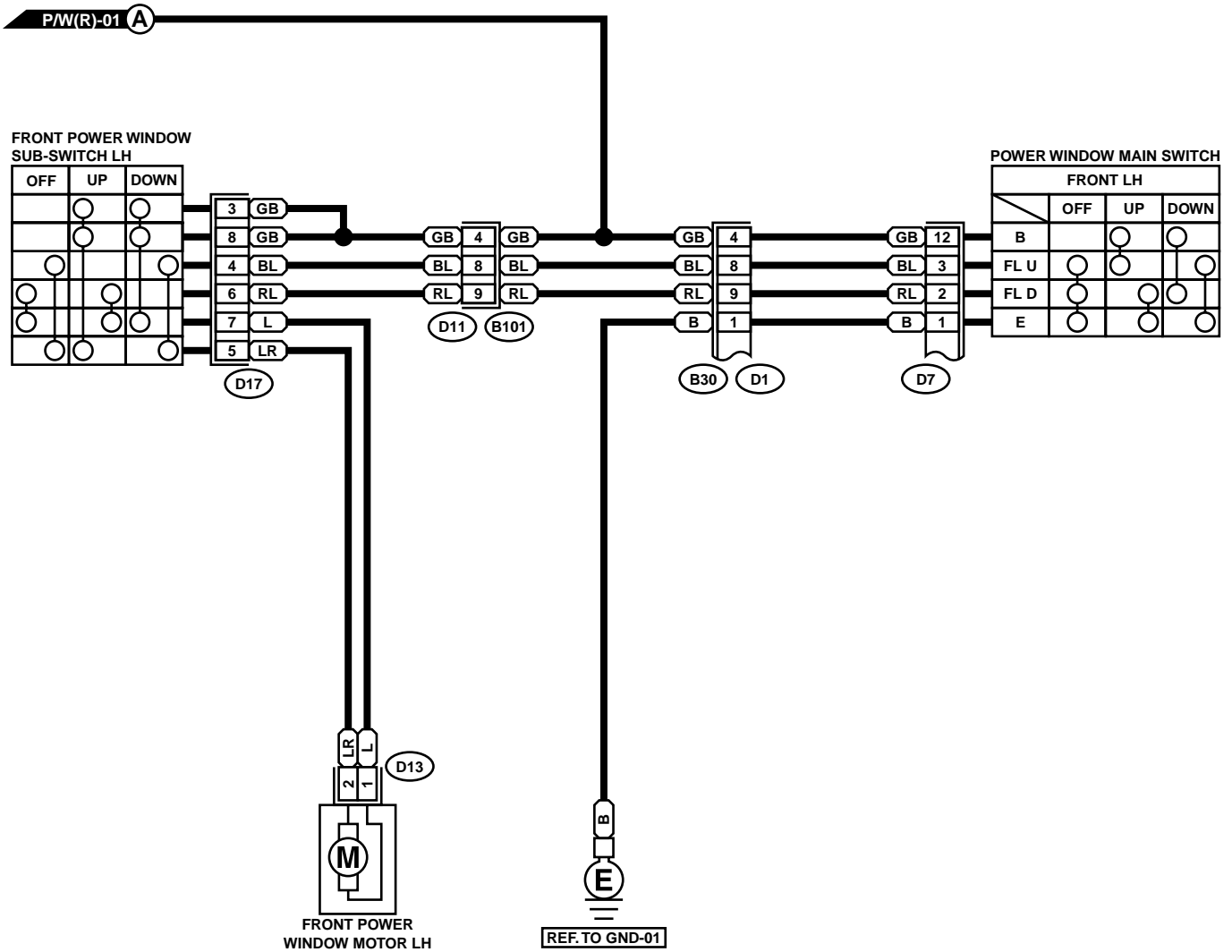

D13 (GREEN)



D17

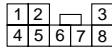

D7

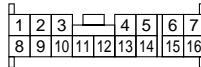

D1

D11

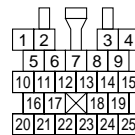

GR70-20B

POWER WINDOW SYSTEM

GLASS/WINDOWS/MIRRORS

P/W(R)-03

P/W(R)-03

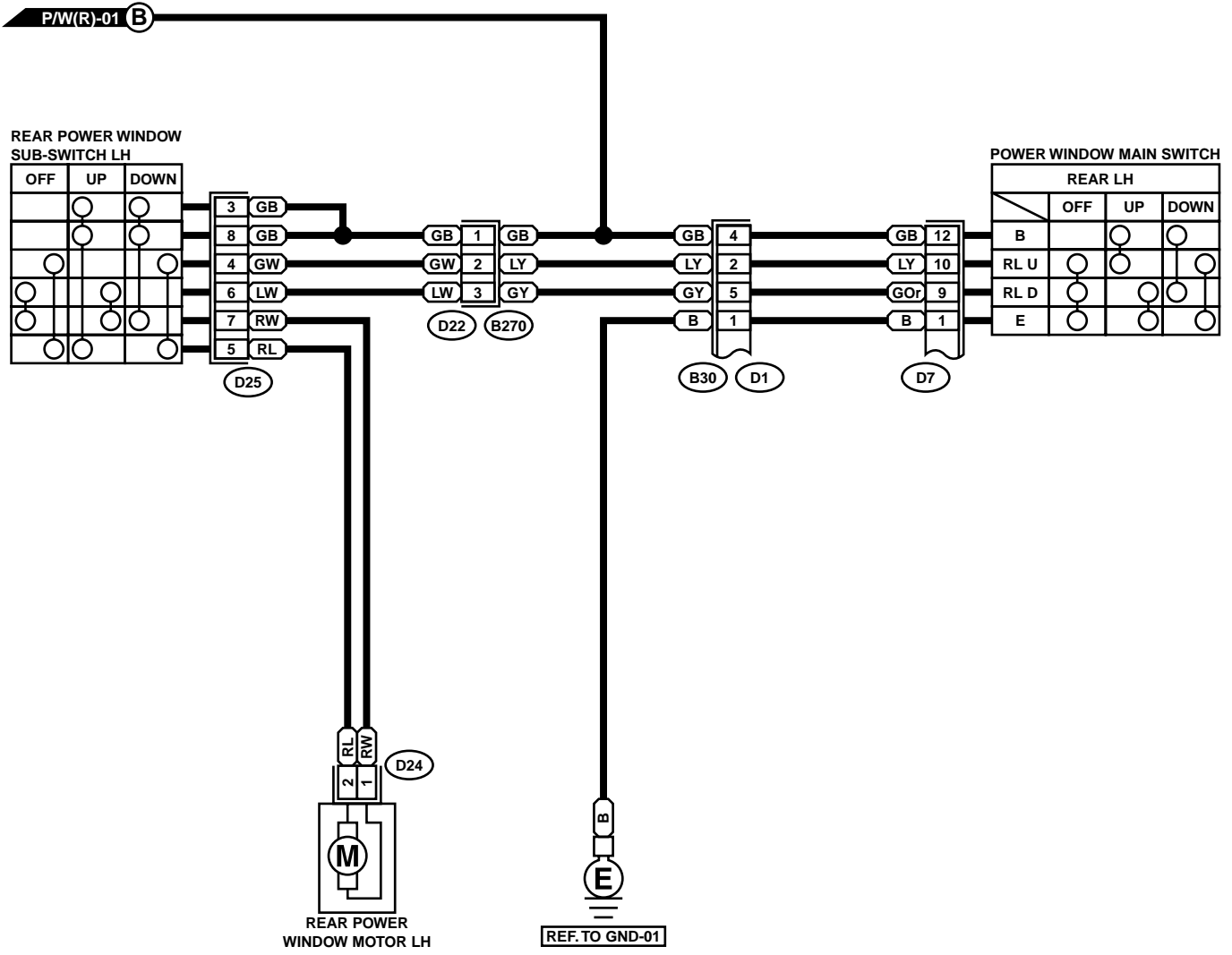

D24 (GREEN)



D22



D25

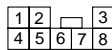

D7

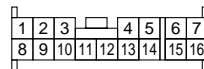

D1

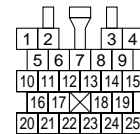

GR70-20C

POWER WINDOW SYSTEM

GLASS/WINDOWS/MIRRORS

P/W(R)-04

P/W(R)-04

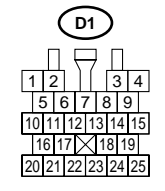
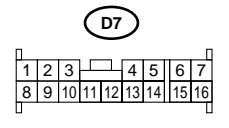
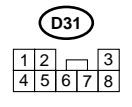
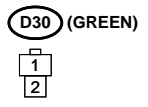
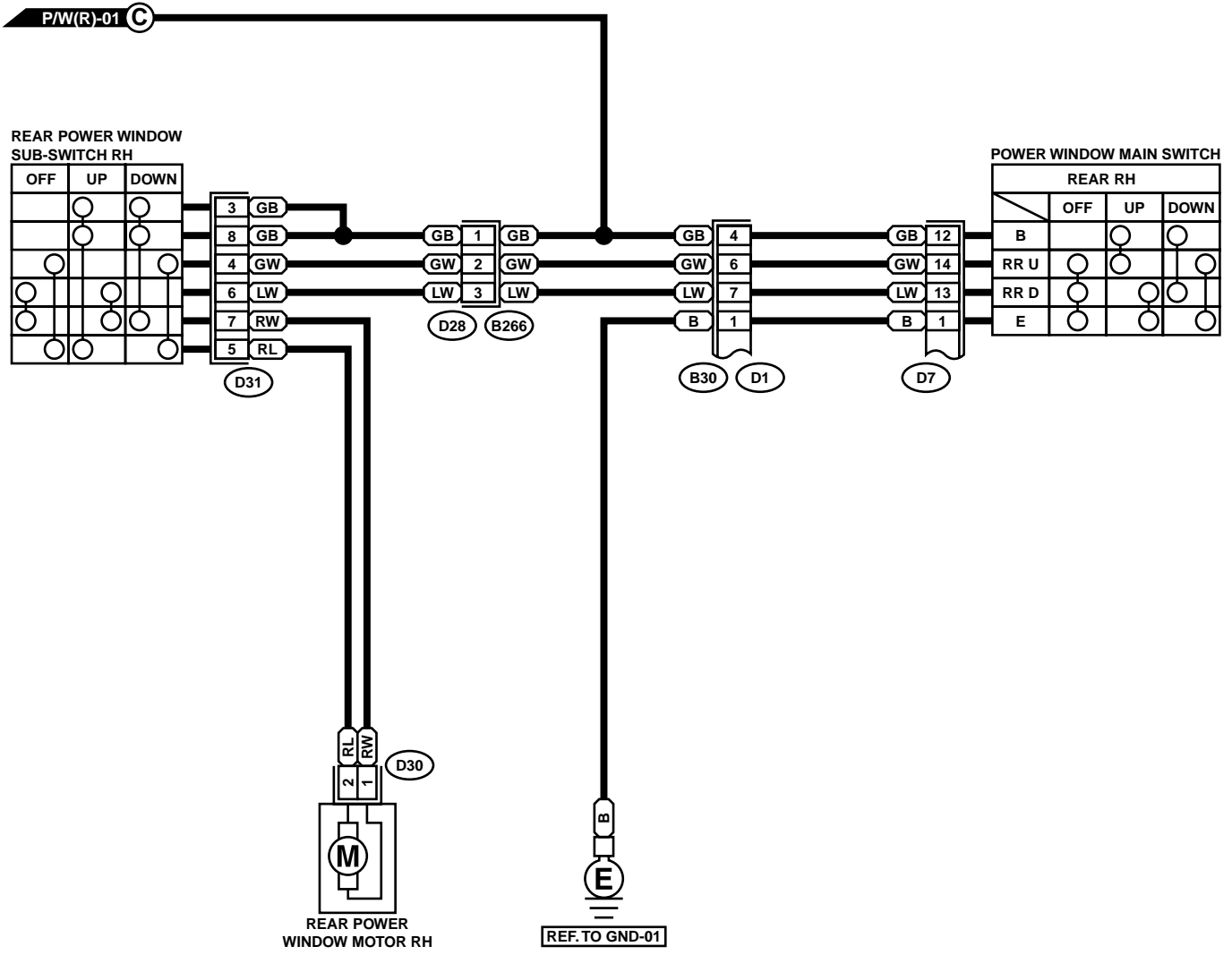

GR70-20D

POWER WINDOW SYSTEM

GLASS/WINDOWS/MIRRORS

B: INSPECTION

Symptom	Repair order
All power windows does not operate.	(1) Fuse (SBF-6) (F/B No. 18: RHD model) (2) Power window circuit breaker (3) Power window relay (4) Wire harness
One window does not operate.	(1) Power window main switch (2) Power window sub switch (3) Power window motor (4) Wire harness
"Window Lock" does not operate.	(1) Power window main switch

3. Rear Window Defogger System

A: SCHEMATIC

REAR WINDOW DEFOGGER SYSTEM

GLASS/WINDOWS/MIRRORS

1. REAR WINDOW DEFOGGER LHD MODEL

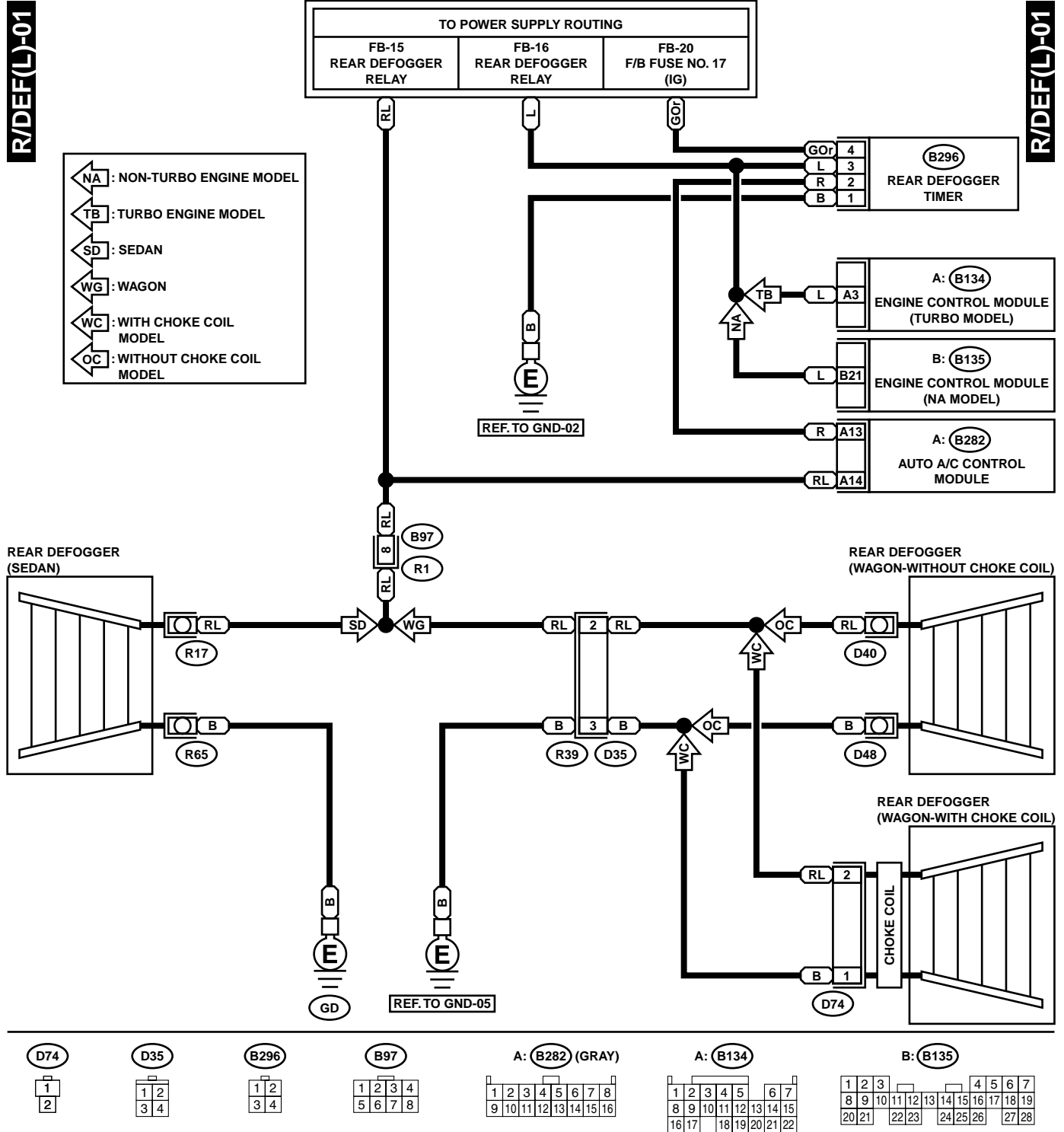

GL52-20

REAR WINDOW DEFOGGER SYSTEM

GLASS/WINDOWS/MIRRORS

2. REAR WINDOW DEFOGGER RHD MODEL

R/DEF(R)-01

R/DEF(R)-01

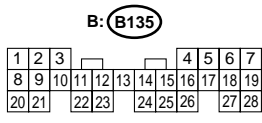
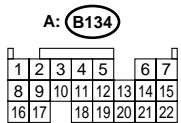
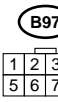
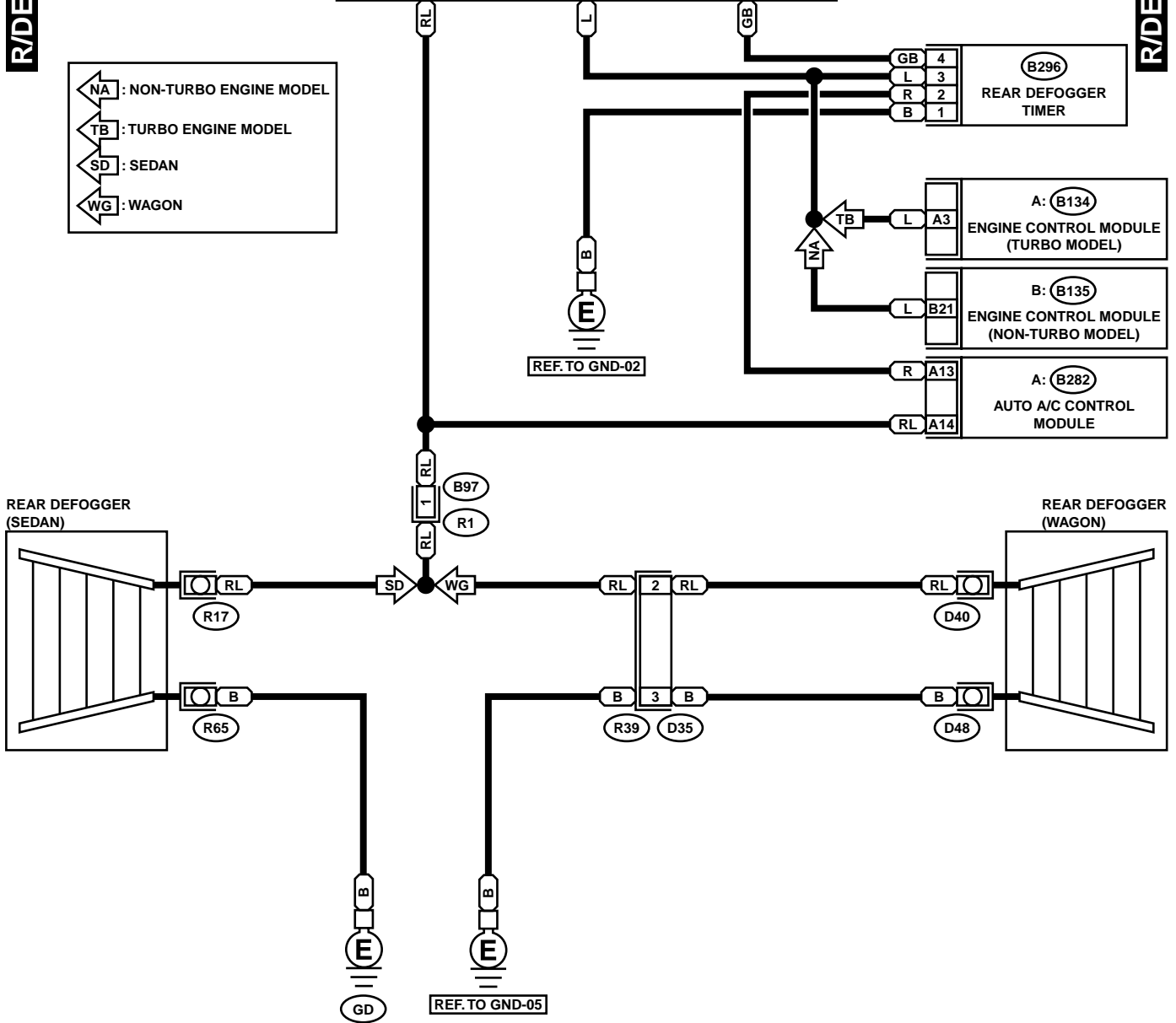
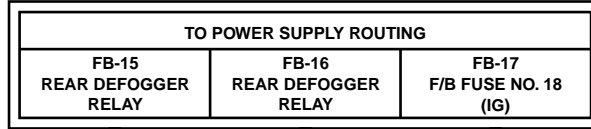
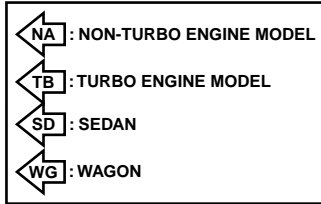

REAR WINDOW DEFOGGER SYSTEM

GLASS/WINDOWS/MIRRORS

B: INSPECTION

Symptom	Repair order
Rear window defogger does not operate.	<ul style="list-style-type: none">(1) Fuse (M/B No. 1) (F/B No. 17)(2) Rear defogger relay(3) Rear defogger timer(4) Defogger switch(5) Rear defogger condenser(6) Deffogger wire(7) Wire harness

4. Remote Control Mirror System

A: SCHEMATIC

REMOTE CONTROL MIRROR SYSTEM

GLASS/WINDOWS/MIRRORS

1. REMOTE CONTROL MIRROR LHD MODEL

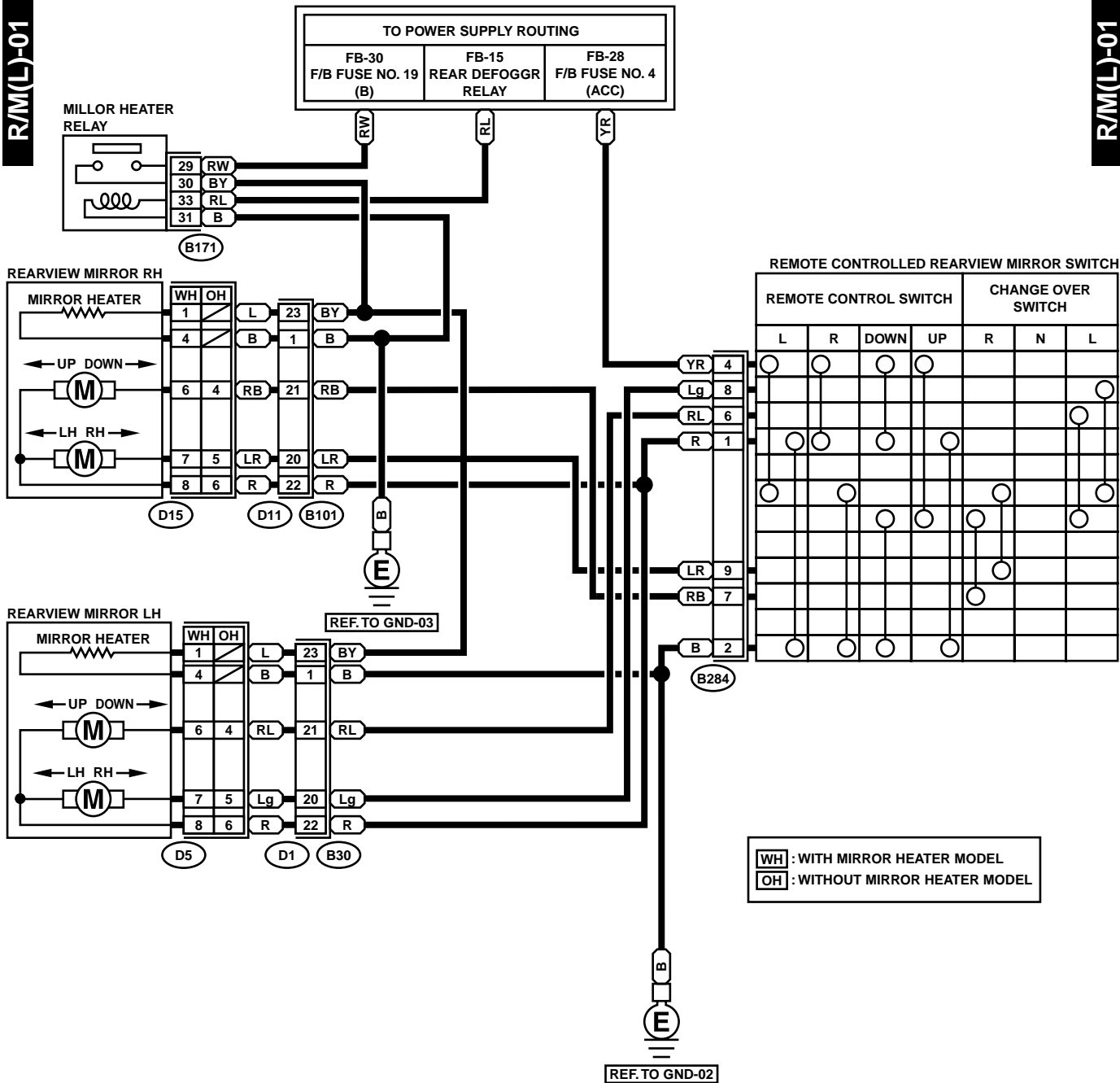

REMOTE CONTROL MIRROR SYSTEM

GLASS/WINDOWS/MIRRORS

2. REMOTE CONTROL MIRROR RHD MODEL

R/M(R)-01

R/M(R)-01

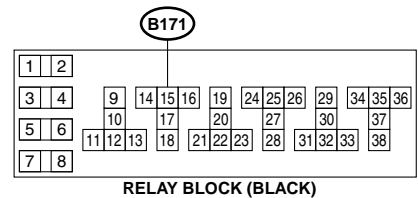
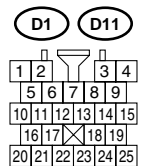
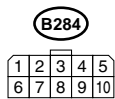
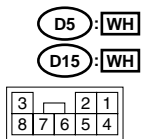
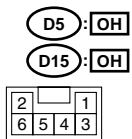
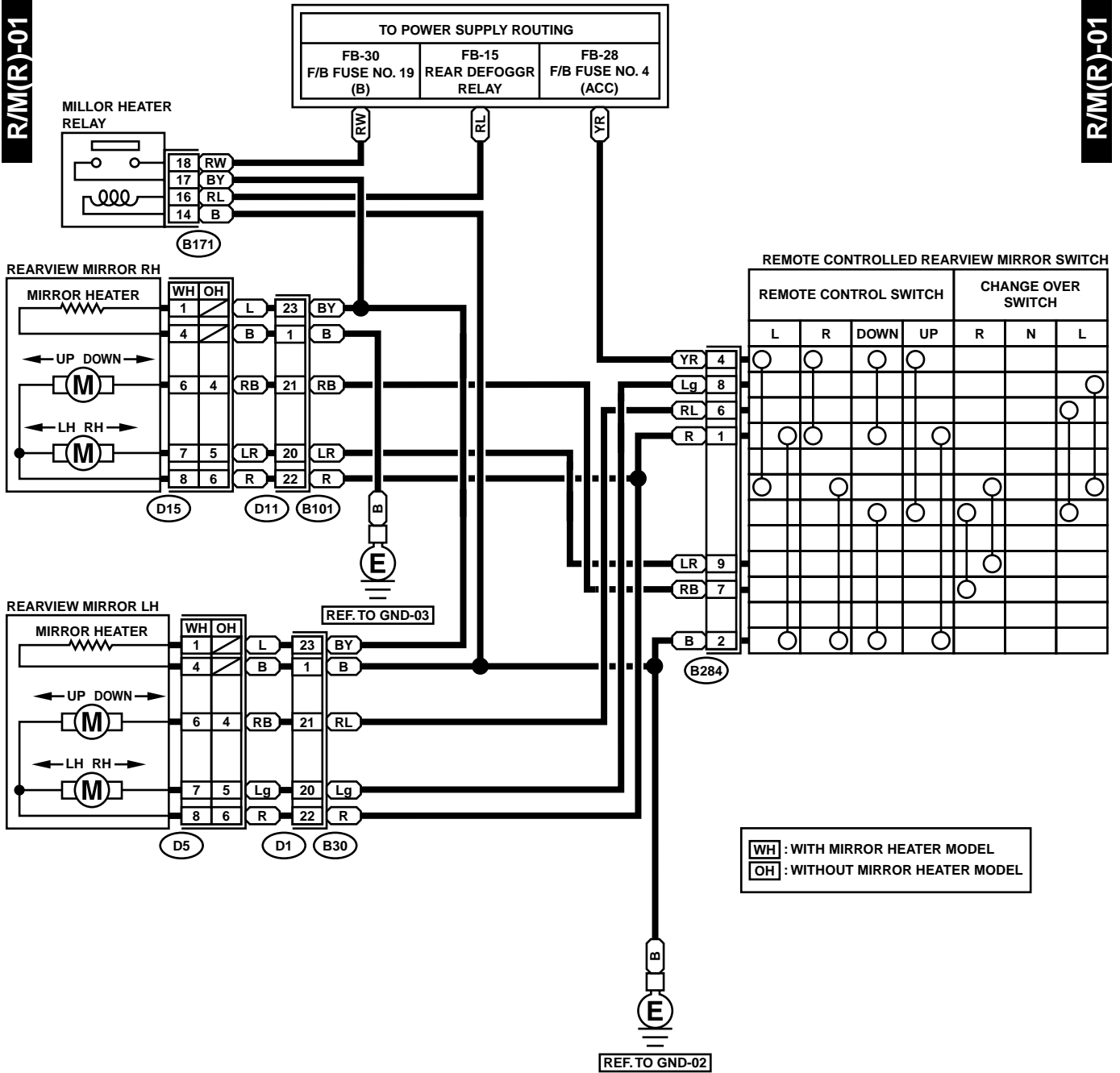

GR79-20

REMOTE CONTROL MIRROR SYSTEM

GLASS/WINDOWS/MIRRORS

B: INSPECTION

Symptom	Repair order
All function does not operate.	(1) Fuse (F/B No. 1) (F/B No. 4) (F/B No. 19) (2) Mirror switch (3) Wire harness
One side of the mirror motor does not operate.	(1) Mirror switch (2) Mirror motor (3) Wire harness
Mirror heater does not operate.	(1) Mirror switch (2) Mirror heater (3) Wire harness

5. Front Door Glass

A: REMOVAL

- 1) Remove front door trim. <Ref. to EI-20, REMOVAL, Front Door Trim.>
- 2) Remove sealing cover. <Ref. to EB-13, REMOVAL, Front Sealing Cover.>
- 3) Remove outer mirror assembly. <Ref. to GW-46, REMOVAL, Outer Mirror Assembly.>
- 4) Operate the power window switch to move glass to position shown in the figure, and then remove the two nuts from service holes.

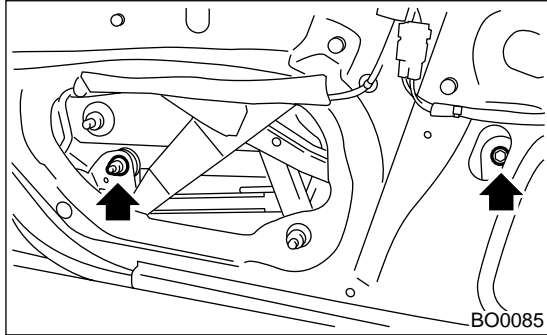

- 5) Remove stabilizers.

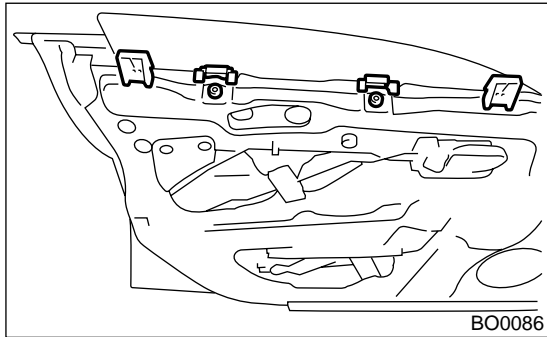

- 6) Remove weather strip outer.

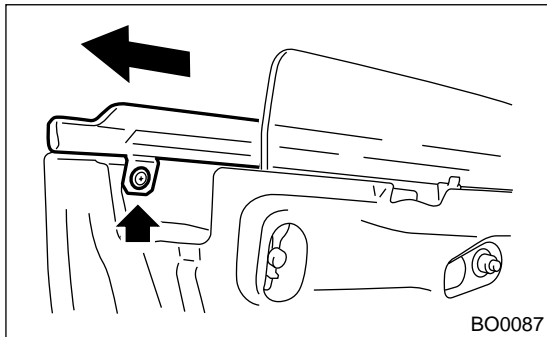

- 7) Remove gusset.

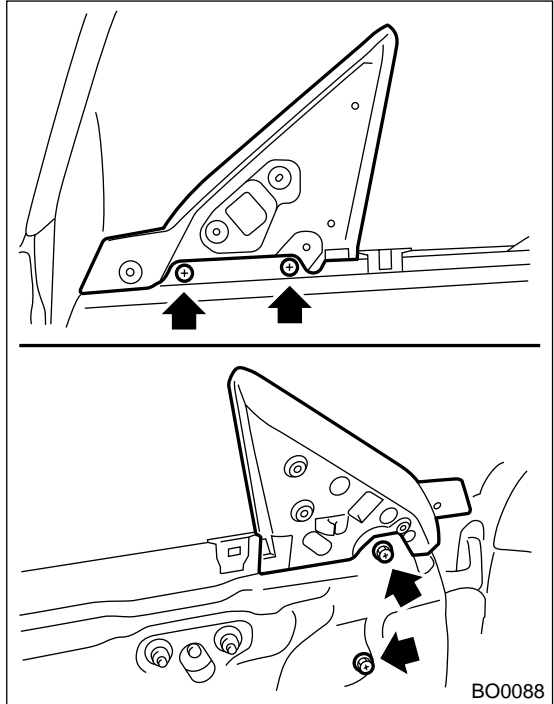

- 8) Take out door glass.

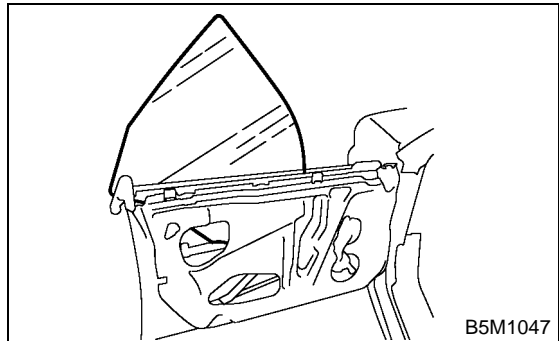

CAUTION:

- Do not turn regulator in the closing direction after removal of the glass. Otherwise gear may be disengaged.
- Avoid impact and damage to the glass.

FRONT DOOR GLASS

GLASS/WINDOWS/MIRRORS

B: INSTALLATION

1) Install in the reverse order of removal.

CAUTION:

Make sure that glass stay is placed securely in sash.

2) Adjust front door glass. <Ref. to GW-29, ADJUSTMENT, Front Door Glass.>

C: ADJUSTMENT

NOTE:

Before adjustment, ensure that all adjusting bolts of stabilizer, upper stopper, and sash are loose and door glass is raised so that it is in contact with weatherstrip.

- 1) Temporarily tighten one adjusting bolt on one side of rear sash at the midpoint of slotted hole in the inner panel.
- 2) Temporarily tighten regulator B-channel in a position slightly lower than midpoint of slotted hole.
- 3) Lower door glass 10 to 15 mm (0.39 to 0.59 in) from fully closed position. While applying outward pressure of 49.0 ± 4.9 N (5.0 ± 0.5 kg, 11.0 ± 1.1 lb) (F) to upper edge of glass above midpoint of two outer stabilizers, press inner stabilizer until it just touches the glass, then secure it.

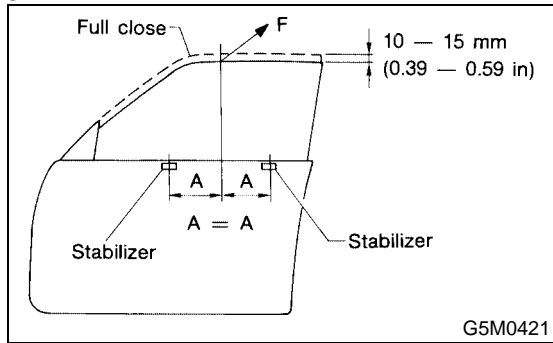

- 4) For adjustment of clearance between front and rear glasses, loosen nuts (A), and move glass sash back and forward until clearance becomes the value shown.

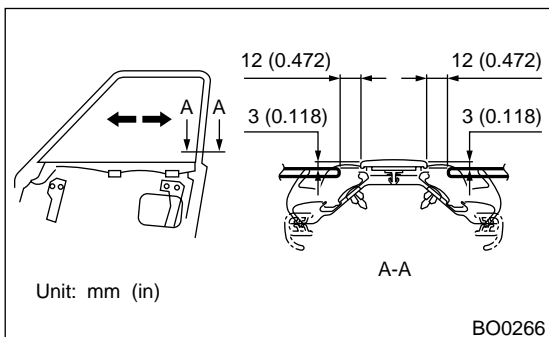
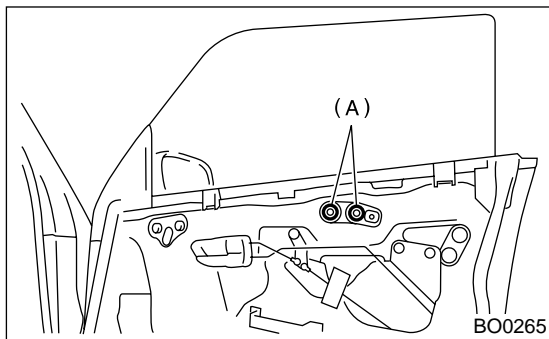

- 5) For adjustment of upper and lower ends of center pillar, loosen adjusting nut (A) of B-channel (B).

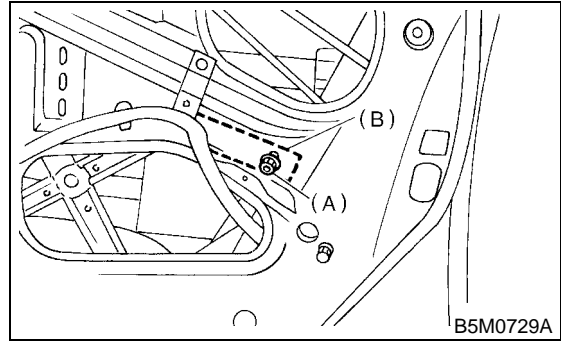

- 6) Adjust so that upper and lower ends of center pillar are the same size.

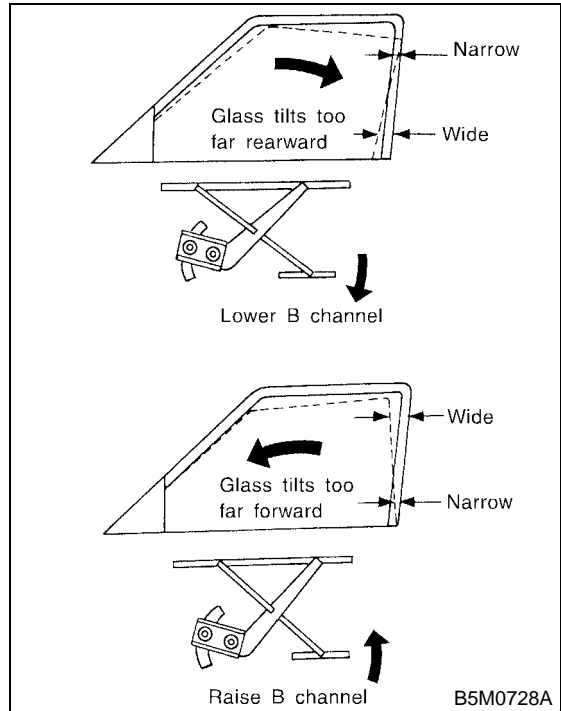

- 7) For glass stroke adjustment, close door, raise glass until positional relationship between glass and weatherstrip becomes as shown. And secure the glass so that upper stopper lightly touches the glass holder.

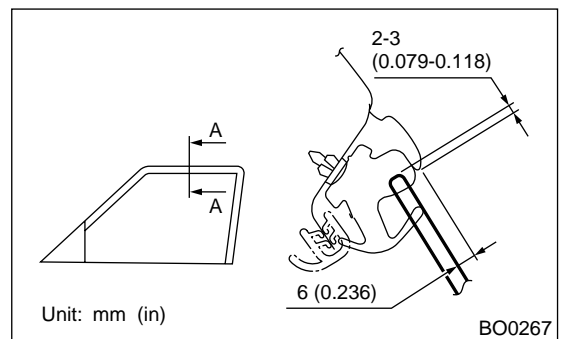

FRONT DOOR GLASS

GLASS/WINDOWS/MIRRORS

8) After stabilizer adjustment, carry out glass crimp adjustment. First, visually ensure positional relationship between retainer & molding and glass of the roof side, and then begin with rear sash adjustment. Adjust two adjusting bolts alternately step by step to obtain dimensions shown below (cross-section A).

NOTE:

If two nuts are loosened at the same time, sash moves back and forth. Therefore, when one nut is adjusted, secure the other.

9) Make the same adjustment of two adjusting bolts of rear sash.

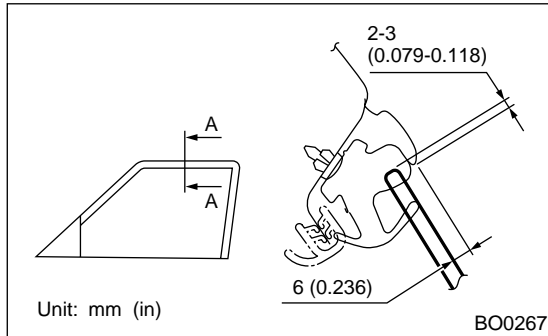

CAUTION:

Do not tilt sash bracket to inner panel during adjustment. Otherwise smooth regulator operation cannot be achieved.

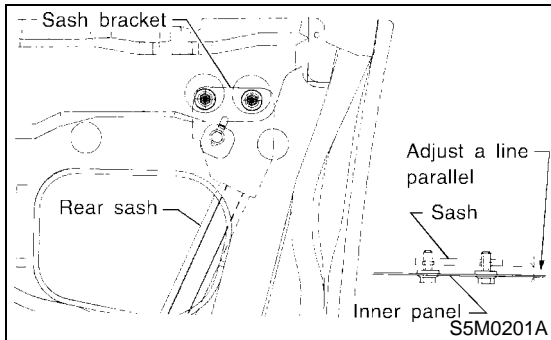

10) Make adjustment of front sash in the same manner as that of rear sash.

CAUTION:

Although front and rear sashes must, as a rule, be adjusted in the same manner, in some door installation, the adjustment in a different manner may be required. However, adjustment of one sash to the maximum amount and the other to the minimum amount is not permitted. Such adjustment may result in application of excessive load to regulator.

11) After adjustments, tighten nuts.

12) After adjustment of glass, if there is a gap between outer lip of gusset and glass surface, adjust the gap with adjusting bolt (A) in lower fitting part of gusset to prevent generation of wind noise.

13) During adjustments, loosen other three clamping bolts.

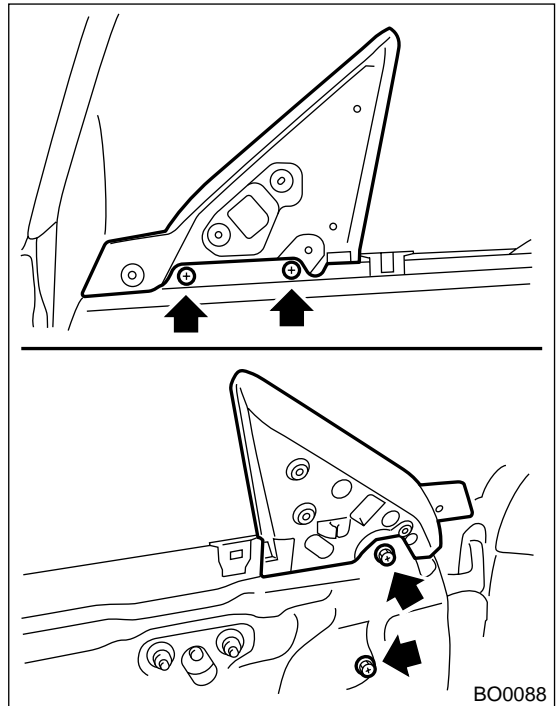

14) After adjustment, tighten bolts and nuts.

6. Front Regulator and Motor Assembly

A: REMOVAL

- 1) Remove door glass. <Ref. to GW-27, REMOVAL, Front Door Glass.>
- 2) Loosen nuts to remove rear sash.

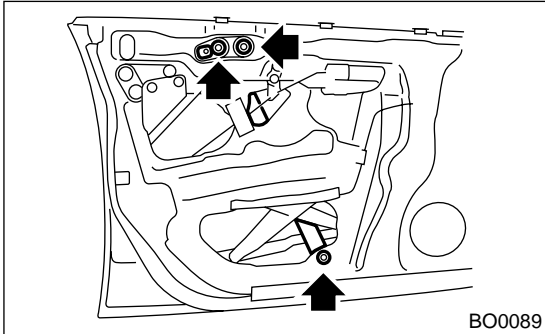

- 3) Disconnect motor connector.
- 4) Loosen four bolts and two nuts to remove regulator assembly.

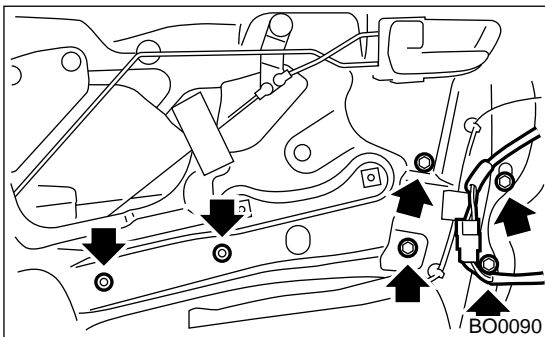

- 5) Loosen screw to remove motor assembly.

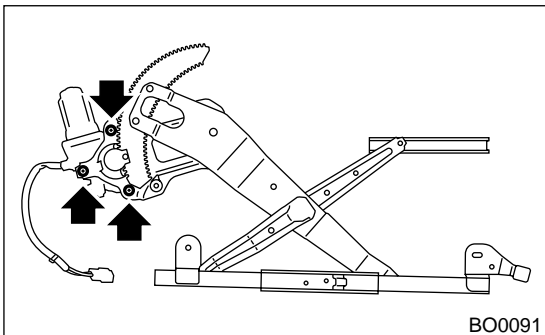

B: INSTALLATION

- 1) Install in the reverse order of removal.
- 2) Adjust front door glass. <Ref. to GW-29, ADJUSTMENT, Front Door Glass.>

C: INSPECTION

- 1) Make sure that power window motor rotates properly when battery voltage is applied to terminals of motor connector.
- 2) Change polarity of battery connections to terminals to ensure that motor rotates in reverse direction.

REAR DOOR GLASS

GLASS/WINDOWS/MIRRORS

7. Rear Door Glass

A: REMOVAL

- 1) Remove rear door trim. <Ref. to EI-21, REMOVAL, Rear Door Trim.>
- 2) Remove sealing cover. <Ref. to EB-16, REMOVAL, Rear Sealing Cover.>
- 3) Remove stabilizer.

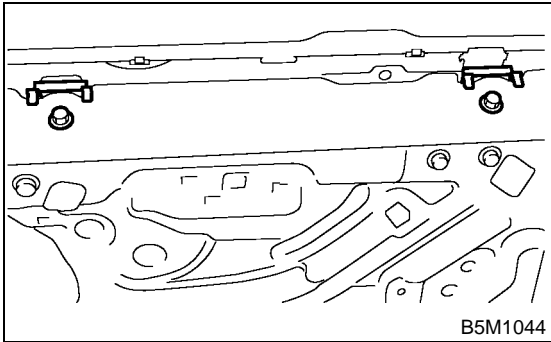

- 4) Remove door weather strip.

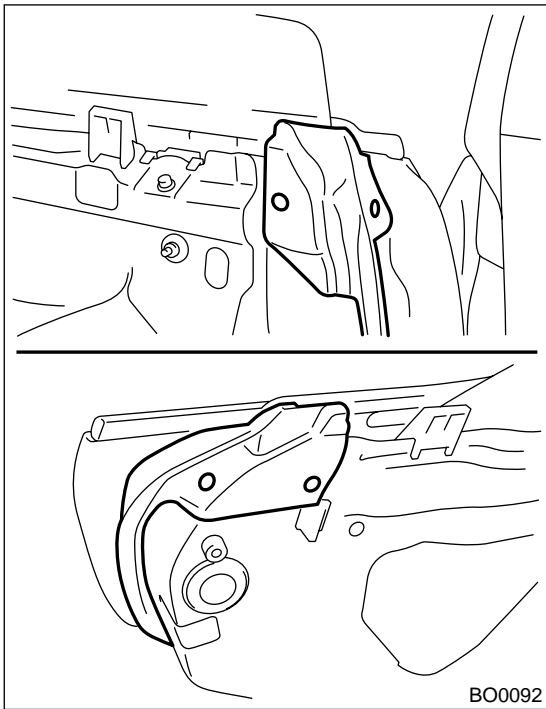

- 5) Loosen two screw to remove weather strip outer.

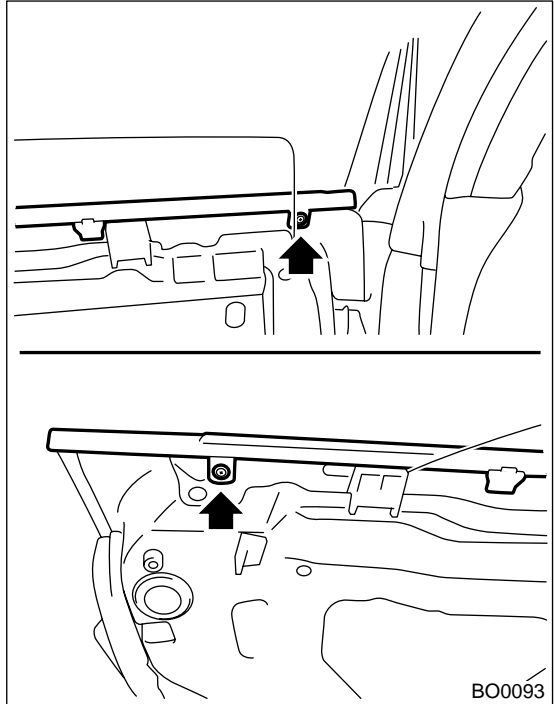

- 6) Operate power window switch to remove glass as shown in the figure, and remove two nuts.

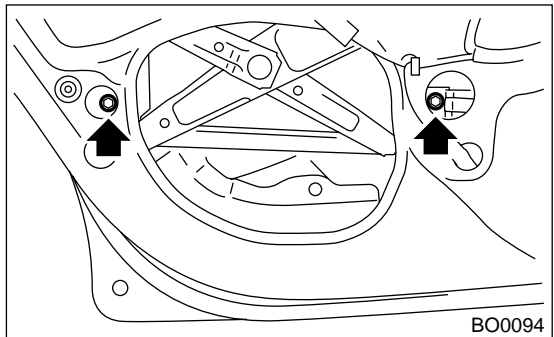

- 7) Remove two nuts, and then separate front sash and glass stay.

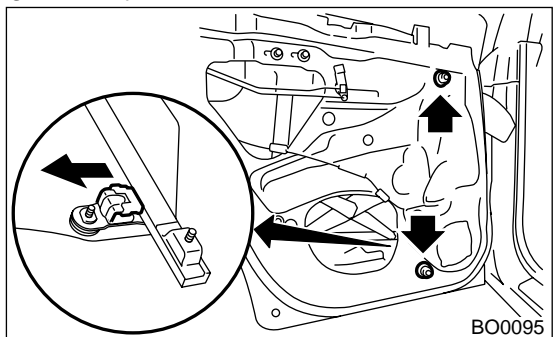

- 8) Pull out glass.

CAUTION:
Avoid impact and damage to the glass.

B: INSTALLATION

1) Install in the reverse order of removal.

CAUTION:

Make sure that glass stay is placed securely in sash.

2) Adjust rear door glass. <Ref. to GW-33, ADJUSTMENT, Rear Door Glass.>

C: ADJUSTMENT

NOTE:

Rear door glass, as a rule, should be adjusted in the same manner as front glass, although they are different in dimension. Special notes for rear glass are given below.

1) Adjust glass position using the following dimensions as a guide line.

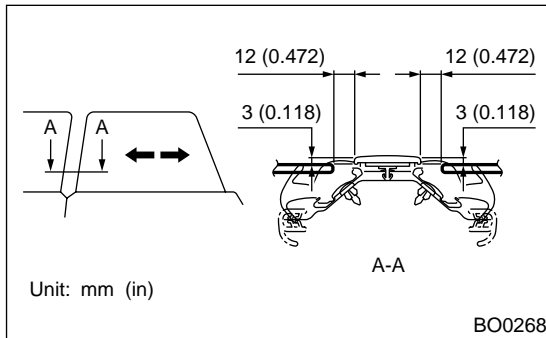

CAUTION:

- If dimensions are smaller than the given dimensions, glass may get caught in weatherstrip during lifting/lowering operation. In the worst case, it may cause glass not to be opened fully.

- After adjustment, move glass up and down to check whether it is caught.

2) Adjust crimp of glass using the following dimensions as a guide line.

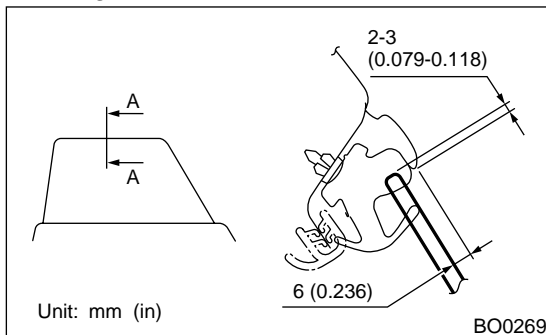

CAUTION:

- If crimp of rear glass is higher than necessary, glass may get caught in weatherstrip of center pillar corner, resulting in early wear of weatherstrip. Be careful when adjusting.

- After adjustment, move glass up and down to check whether it is caught.

REAR REGULATOR AND MOTOR ASSEMBLY

GLASS/WINDOWS/MIRRORS

8. Rear Regulator and Motor Assembly

A: REMOVAL

- 1) Remove door glass. <Ref. to GW-32, REMOVAL, Rear Door Glass.>
- 2) Disconnect motor connector.
- 3) Loosen four bolts and two nuts to remove regulator assembly.

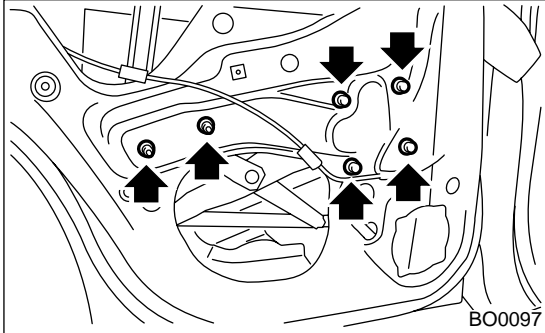

- 4) Loosen screws to remove motor assembly.

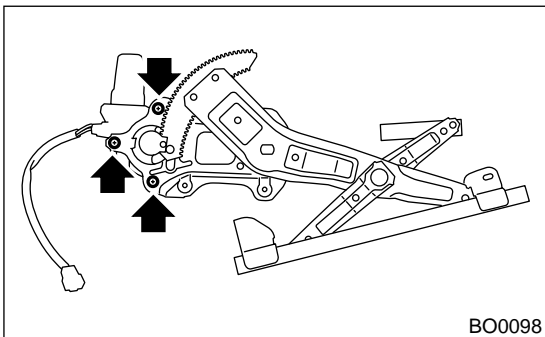

B: INSTALLATION

- 1) Install in the reverse order of removal.
- 2) Adjust rear door glass. <Ref. to GW-33, ADJUSTMENT, Rear Door Glass.>

C: INSPECTION

- 1) Make sure that power window motor rotates properly when battery voltage is applied to terminals of motor connector.
- 2) Change polarity of battery connections to terminals to ensure that motor rotates in reverse direction.

9. Windshield Glass

A: REMOVAL

1. USING WINDSHIELD KNIFE

- 1) Remove cowl panel. <Ref. to EI-17, REMOVAL, Cowl Panel.>
- 2) Remove glass molding.
- 3) Tape body side of the circumference of windshield glass for protection.
- 4) Apply sufficient amount of soapy water to adhesive layer.
- 5) Insert windshield knife into the adhesive layer.
- 6) While holding the knife edge and windshield glass edge at a right angle, move windshield knife in parallel to windshield glass edge along face and edge of windshield glass to cut the adhesive layer.

CAUTION:

- Do not twist windshield knife.
- Cutting of adhesive layer shall be started with wider gap between windshield glass and body.

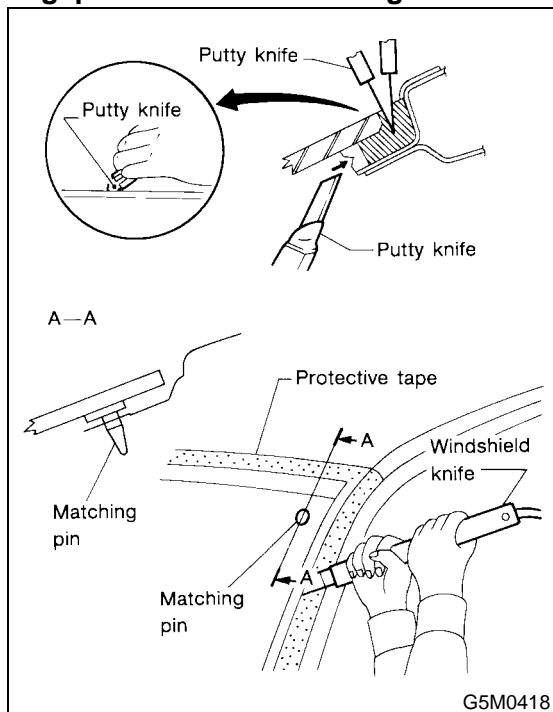

NOTE:

Because matching pins are bonded to the corners of glass, use piano wire to cut the pin.

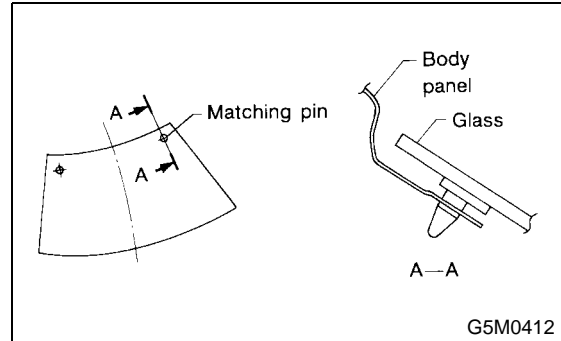

2. USING PIANO WIRE

- 1) Remove cowl panel. <Ref. to EI-17, REMOVAL, Cowl Panel.>
- 2) Remove roof molding and upper front molding.
- 3) Tape the body side of the circumference of windshield glass for protection.
- 4) Make a hole in adhesive layer using drill or knife.
- 5) Pass piano wire through the hole, and attach securely both the wire ends to pieces of wood.

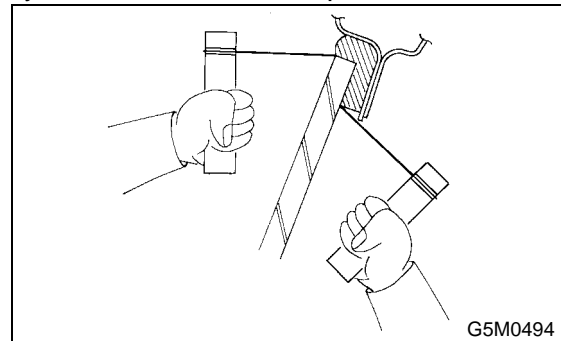

- 6) Pull the wire ends alternately to cut off the adhesive layer.

CAUTION:

- Do not tightly pull the piano wire against the windshield glass edge.
- Be careful not to damage interior and exterior parts.
- When removal is made with area close to instrument panel, place a protection plate over it. Pay particular attention to the removal.
- Do not cross piano wires. Otherwise they may be cut.

WINDSHIELD GLASS

GLASS/WINDOWS/MIRRORS

B: INSTALLATION

- 1) Clean external circumference of windshield glass with alcohol or white gasoline.
- 2) Remove adhesive layer on the body using cutter knife to obtain smooth face 2 mm (0.08 in) thick.

CAUTION:

Be careful not to damage the body and paint surface.

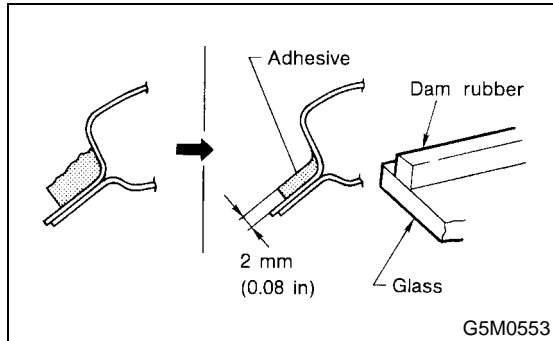

- 3) Clean body with alcohol or white gasoline to remove thoroughly chips, dusts, and dirt from body face.
- 4) Place glass on body.
- 5) Adjust glass position to make uniform clearance between body and glass in four corners.
- 6) Place matching pins and body on glass.

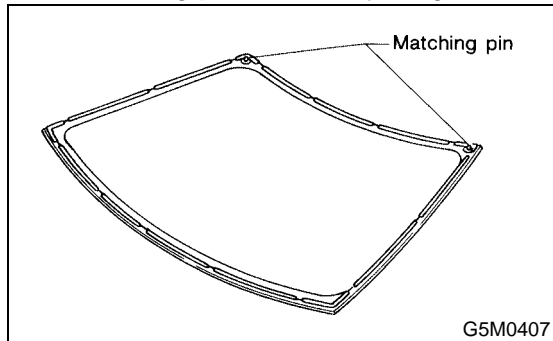

- 7) Remove glass from body.

- 8) Fit molding mark (B) to notch (A).

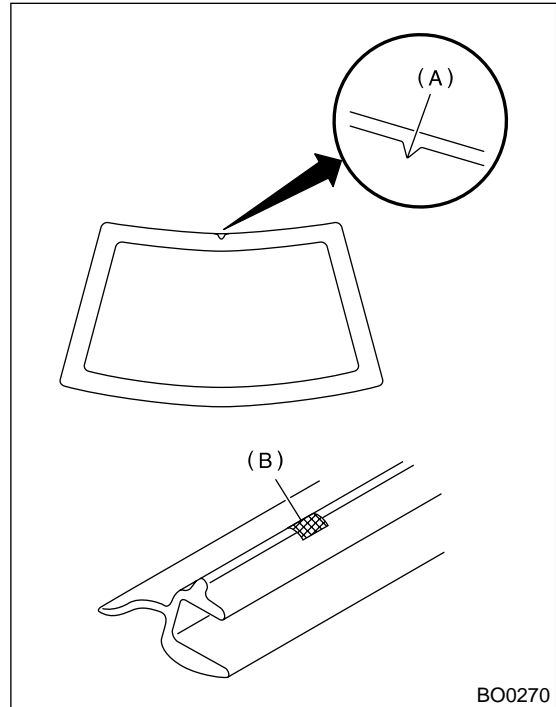

- 9) Apply primer to adhesive layer of glass using sponge.
- 10) Apply primer to adhesive layer of body.

CAUTION:

- Primer once attached to the painted surface of the body and internal trim is hard to wipe off. Mask the circumference of such areas.
- Let primer dry for about ten minutes before installing the glass.
- Do not touch surface coated with primer.

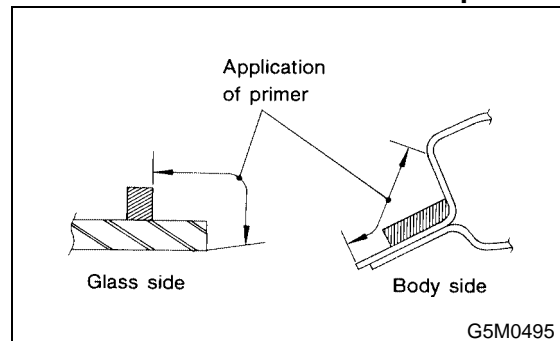

- 11) Cut off cartridge nozzle tip and set it in sealant gun as shown.

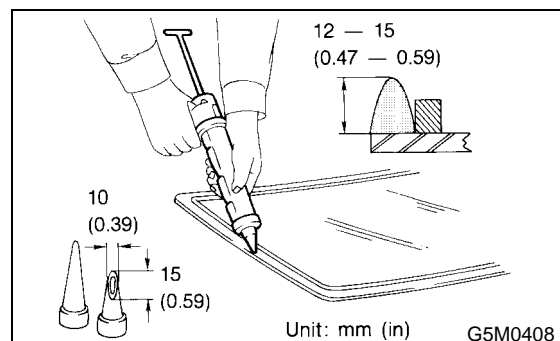

- 12) Apply adhesive to glass end surface as shown.
- 13) Fit matching pins using suction rubber cup to install windshield glass.

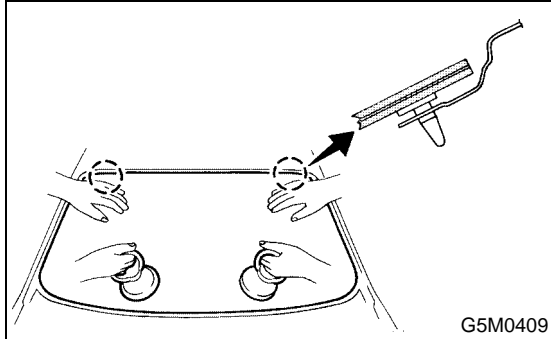

- 14) Lightly press windshield glass for tight fit.
- 15) Make adhesive surface flush using spatula.

CAUTION:

- When door is opened/closed after glass is bonded, always lower door glass and then open/close it carefully.
- Move vehicle slowly.

- 16) After completion of all work, allow vehicle to stand for about 24 hours.

NOTE:

For minimum drying time and time the vehicle must be left standing before driving after bonding, follow instructions or instruction manual from the adhesive manufacturer.

- 17) After curing of adhesive, pour water on external surface of vehicle to check that there are no water leaks.

CAUTION:

When a vehicle is returned to the user, tell him or her that the vehicle should not be subjected to heavy impact for at least three days.

- 18) Install cowl panel. <Ref. to EI-17, INSTALLATION, Cowl Panel.>

REAR GATE GLASS

GLASS/WINDOWS/MIRRORS

10. Rear Gate Glass

A: REMOVAL

- 1) Remove rear wiper motor. <Ref. to WW-21, REMOVAL, Rear Wiper Motor.>
- 2) Remove electrical connector from rear defogger terminal.
- 3) Remove glass in the same procedure as for windshield glass. <Ref. to GW-35, REMOVAL, Windshield Glass.>

B: INSTALLATION

- 1) Apply adhesive evenly to the glass attachment area.
- 2) Insert the glass clip pin into the rear gate hole, and after pushing on the area around the clip pin to secure it, push lightly all around the area to seal it.
- 3) About one hour after installation, conduct a leak test.

CAUTION:

When a vehicle is returned to the user, tell him or her that the vehicle should not be subjected to heavy impact for at least three days.

5) Connect rear defogger terminals.

6) Install rear wiper. <Ref. to WW-21, INSTALLATION, Rear Wiper Motor.>

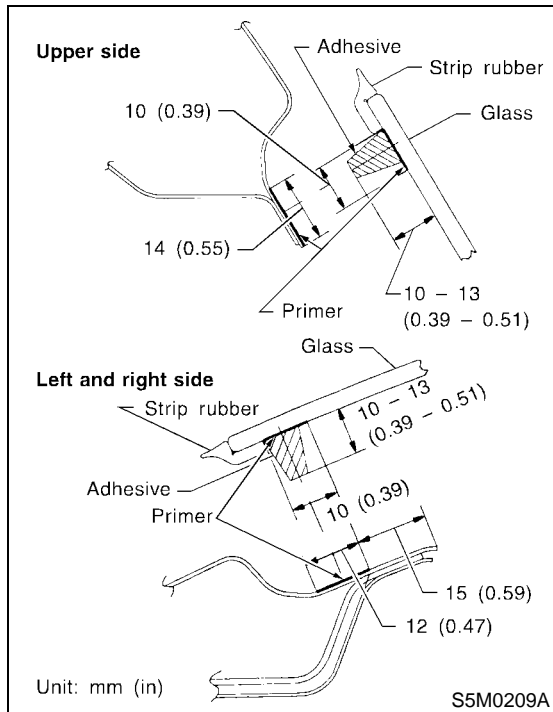

CAUTION:

- When door is opened/closed after glass is bonded, always lower door glass and then open/close it carefully.
- Move vehicle slowly.

4) After completion of all work, allow vehicle to stand for about 24 hours.

NOTE:

For minimum drying time and time the vehicle must be left standing before driving after bonding, follow instructions or instruction manual from the adhesive manufacturer.

11.Rear Quarter Glass

A: REMOVAL

1. SEDAN

Remove glass in the same procedure as for windshield glass. <Ref. to GW-35, REMOVAL, Windshield Glass.>

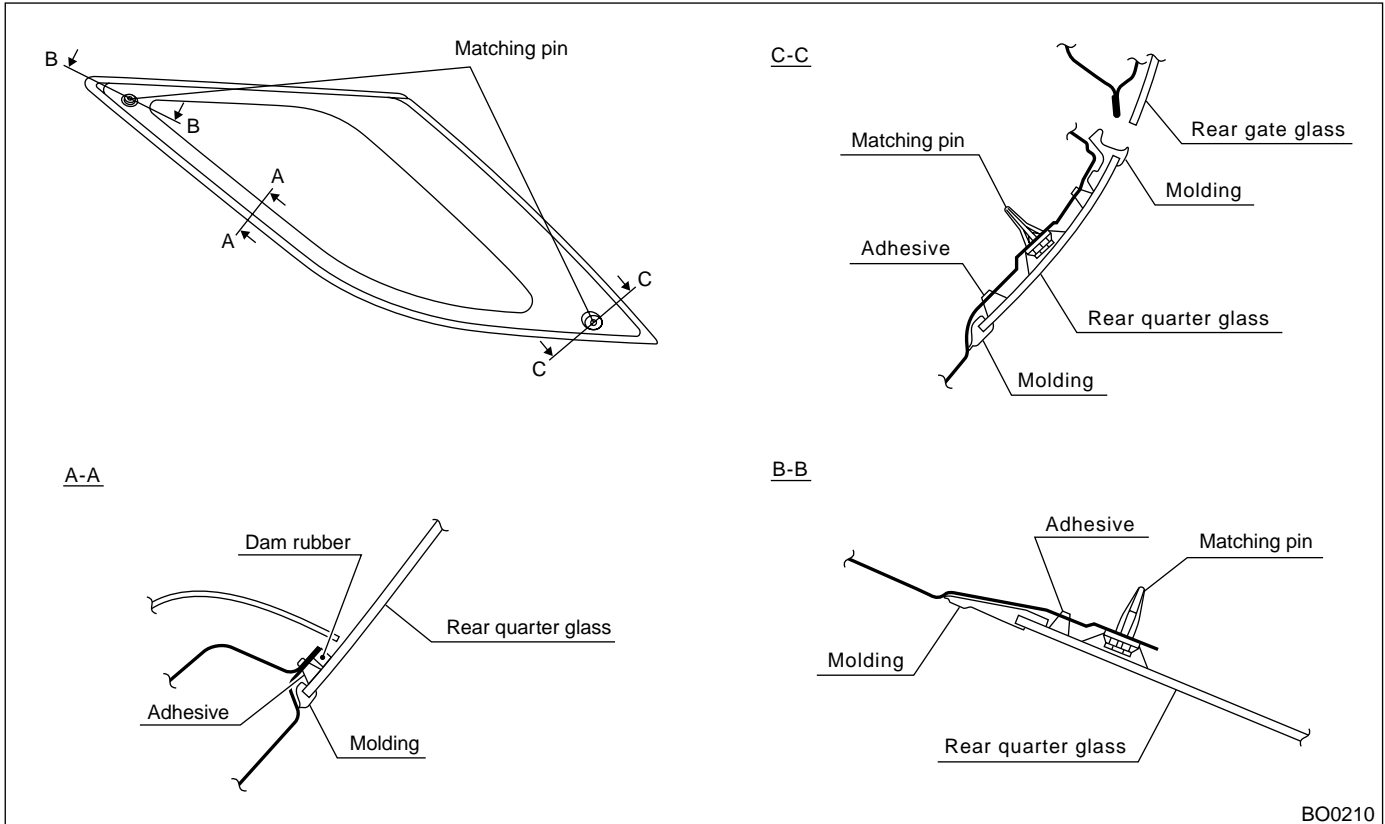

2. WAGON

Remove glass in the same procedure as for windshield glass. <Ref. to GW-35, REMOVAL, Windshield Glass.>

B: INSTALLATION

1) Cut off nozzle tip as shown in the figure.

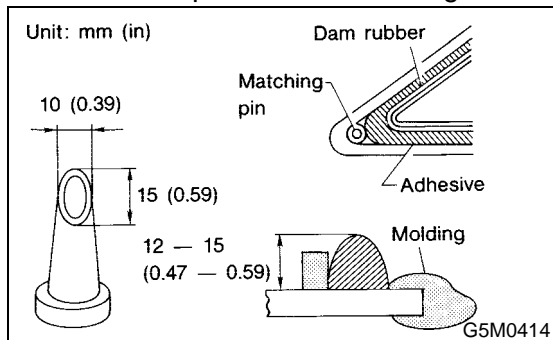

2) Install glass in the same procedure as for windshield glass. <Ref. to GW-36, INSTALLATION, Windshield Glass.>

CAUTION:

- When door is opened/closed after glass is bonded, always lower door glass and then open/close it carefully.

- Move vehicle slowly.

3) After completion of all work, allow vehicle to stand for about 24 hours.

NOTE:

For minimum drying time and time the vehicle must be left standing before driving after bonding, follow instructions or instruction manual from the adhesive manufacturer.

4) After curing of adhesive, pour water on external surface of vehicle to check that there are no water leaks.

CAUTION:

When a vehicle is returned to the user, tell him or her that the vehicle should not be subjected to heavy impact for at least three days.

12.Rear Window Glass

A: REMOVAL

- 1) Disconnect electrical connectors from rear defogger terminals.
- 2) Remove glass in the same procedure as for windshield glass. <Ref. to GW-35, REMOVAL, Windshield Glass.>

B: INSTALLATION

- 1) Bond dam rubber and matching pin.

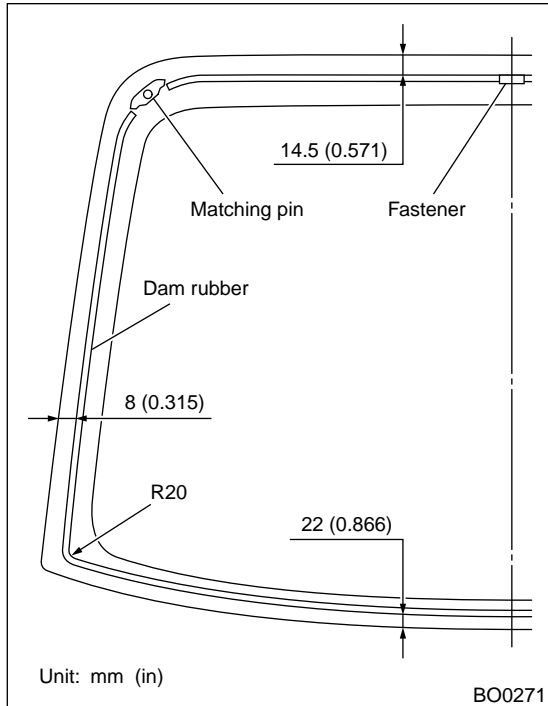

- 2) Install glass in the same procedure as for windshield glass. <Ref. to GW-36, INSTALLATION, Windshield Glass.>
- 3) Connect rear defogger terminals.

CAUTION:

- **When door is opened/closed after glass is bonded, always lower door glass and then open/close door carefully.**
- **Move vehicle slowly.**

- 4) After completion of all work, allow vehicle to stand for about 24 hours.

NOTE:

For minimum drying time and time the vehicle must be left standing before driving after bonding, follow instructions or instruction manual from the adhesive manufacturer.

- 5) After curing of adhesive, pour water on external surface of vehicle to check that there are no water leaks.

CAUTION:

When a vehicle is returned to the user, tell him or her that the vehicle should not be subjected to heavy impact for at least three days.

13.Roof Window Glass

A: REMOVAL

<Ref. to SR-6, REMOVAL, Sunroof Lid.>

B: INSTALLATION

<Ref. to SR-6, INSTALLATION, Sunroof Lid.>

C: ADJUSTMENT

<Ref. to SR-6, ADJUSTMENT, Sunroof Lid.>

14.Inner Rearview Mirror

A: REMOVAL

NOTE:

The spring cannot be reused. Prepare a new spring before removal.

1) Turn mirror base 90 degrees clockwise or counterclockwise to remove it.

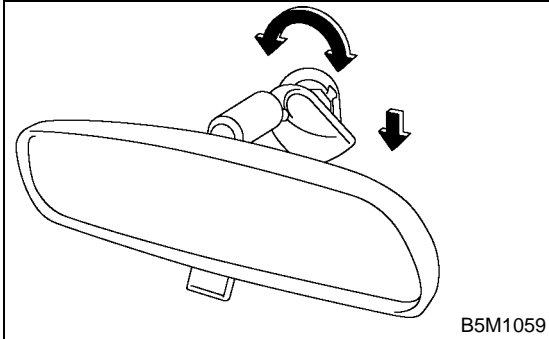

2) Remove spring from mirror base.

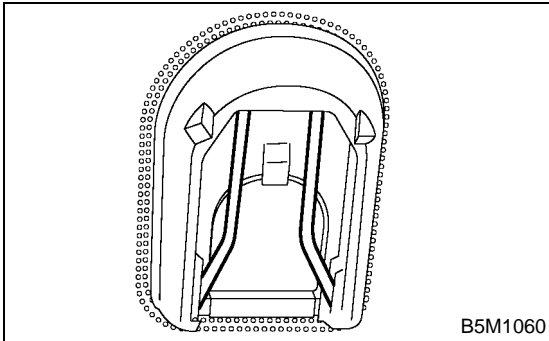

CAUTION:

Be careful not to damage the mirror surface.

B: INSTALLATION

Install in the reverse order of removal.

C: INSPECTION

Do not let mirror be damaged.

Do not let spring deteriorate.

15. Power Window Control Switch

A: REMOVAL

1. MAIN SWITCH

- 1) Loosen screw to remove power window main switch.
- 2) Disconnect the connector.

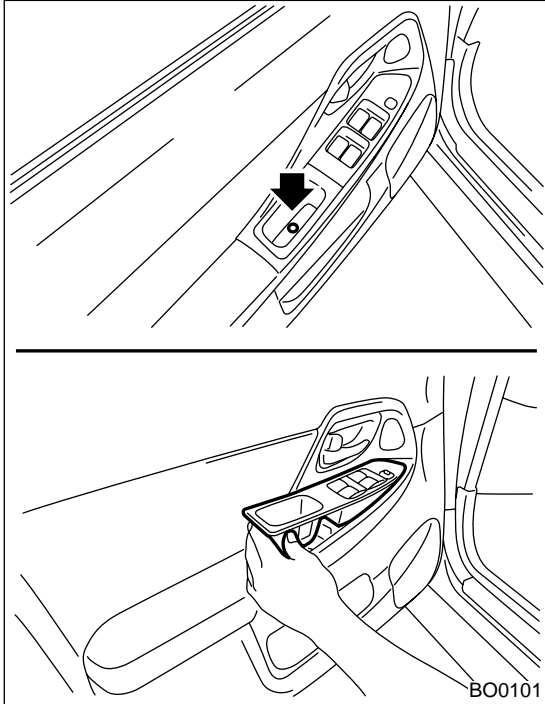

2. SUB-SWITCH

- 1) Remove switch panel.
- 2) Disconnect the connector.

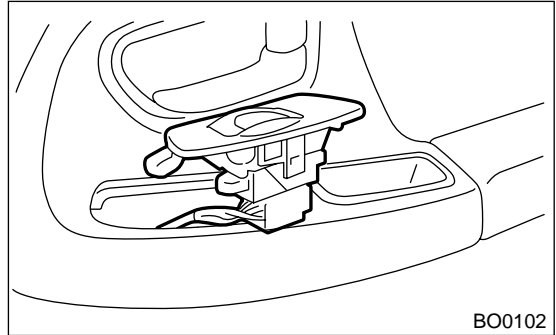

B: INSTALLATION

1. MAIN SWITCH

Install in the reverse order of removal.

2. SUB-SWITCH

Install in the reverse order of removal.

C: INSPECTION

1. MAIN SWITCH LHD MODEL

Check continuity between connector terminals.

Driver's switch:

Switch position	Tester connection	Specified condition
AUTO UP	13 — 2, 1 — 5	Continuity
UP	13 — 2, 1 — 5	Continuity
OFF	2 — 1 — 5	Continuity
DOWN	13 — 1, 2 — 5	Continuity
AUTO DOWN	13 — 1, 2 — 5	Continuity

Front passenger's switch:

Switch position	Tester connection	Specified condition
UP	13 — 6, 7 — 5	Continuity
OFF	6 — 7 — 5	Continuity
DOWN	13 — 7, 6 — 5	Continuity

Rear left switch:

Switch position	Tester connection	Specified condition
UP	10 — 13, 9 — 5	Continuity
OFF	10 — 9 — 5	Continuity
DOWN	13 — 9, 10 — 5	Continuity

POWER WINDOW CONTROL SWITCH

GLASS/WINDOWS/MIRRORS

Rear right switch:

Switch position	Tester connection	Specified condition
UP	13 — 16, 15 — 5	Continuity
OFF	16 — 15 — 5	Continuity
DOWN	13 — 15, 16 — 5	Continuity

If NG, replace the main switch.

2. MAIN SWITCH RHD MODEL

Check continuity between connector terminals.

Driver's switch:

Switch position	Tester connection	Specified condition
AUTO UP	12 — 6, 7 — 1	Continuity
UP	12 — 6, 7 — 1	Continuity
OFF	6 — 7 — 1	Continuity
DOWN	12 — 7, 6 — 1	Continuity
AUTO DOWN	12 — 7, 6 — 1	Continuity

Front passenger's switch:

Switch position	Tester connection	Specified condition
UP	12 — 3, 2 — 1	Continuity
OFF	3 — 2 — 1	Continuity
DOWN	12 — 2, 3 — 1	Continuity

Rear left switch:

Switch position	Tester connection	Specified condition
UP	12 — 10, 9 — 1	Continuity
OFF	10 — 9 — 1	Continuity
DOWN	12 — 9, 10 — 1	Continuity

Rear right switch:

Switch position	Tester connection	Specified condition
UP	12 — 14, 1 — 13	Continuity
OFF	14 — 13 — 1	Continuity
DOWN	12 — 13, 14 — 1	Continuity

If NG, replace the main switch.

3. SUB-SWITCH

Check continuity between connector terminals.

Front passenger's door switch and rear door switch:

Switch position	Tester connection	Specified condition
UP	8 — 5, 6 — 7	Continuity
OFF	4 — 5, 6 — 7	Continuity
DOWN	8 — 7, 4 — 5	Continuity

If NG, replace the sub-switch.

16. Rear Window Defogger

A: INSPECTION

CAUTION:

When wiping stain on glass off with cloth, use a dry and soft cloth and move it in the direction of the heat wire extension to avoid damage to the heat wire.

- 1) Turn ignition switch to ON.
- 2) Turn defogger switch to ON.
- 3) Wrap tips of tester pins with aluminum foil to avoid damage to heat wire.

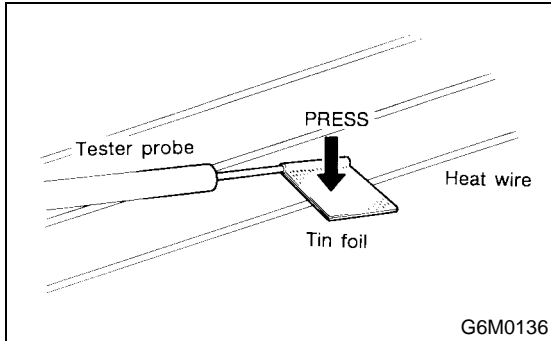

- 4) Measure voltage at wire center with DC voltmeter.

Standard voltage:

Approx. 6 volts

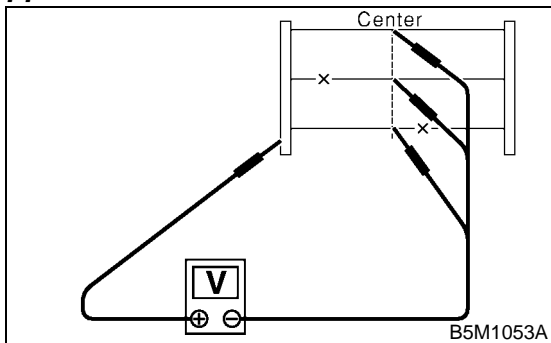

Voltage	Criteria
Approx. 6 V	OK
Approx. 12 V or 0 V	Broken

NOTE:

- If the measured value is 12 volts, heat wire is open between wire center and positive (+) end.
- If zero volt, heat wire is open between wire center and ground.

5) Apply positive lead of voltmeter to positive terminal of voltmeter, and then move negative lead along the wire up to the negative terminal end. If voltage changes from zero to several volts during movement of lead, heat wire is open at the voltage change point.

B: REPAIR

- 1) Clean broken portion with alcohol or white gasoline.
- 2) Mask both side of wire with thin film.
- 3) Apply conductive silver composition (DUPONT No. 4817) to broken portion.

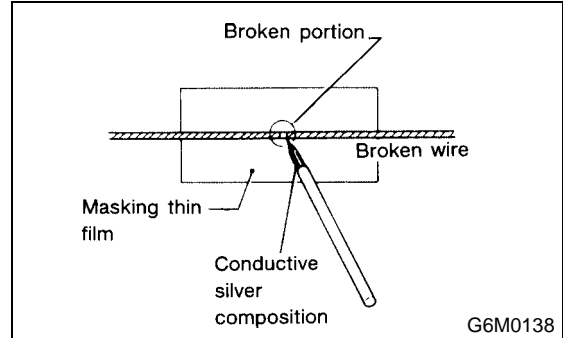

- 4) After repair, check wire.

OUTER MIRROR ASSEMBLY

GLASS/WINDOWS/MIRRORS

17. Outer Mirror Assembly

A: REMOVAL

- 1) Remove door trim. <Ref. to EI-20, REMOVAL, Front Door Trim.>
- 2) Remove mirror gusset cover.

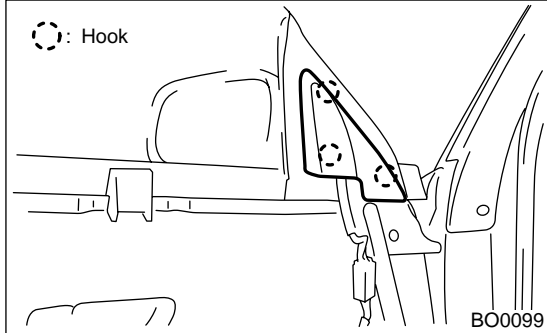

- 3) Disconnect the mirror connector.
- 4) Loosen screws to remove mirror assembly.

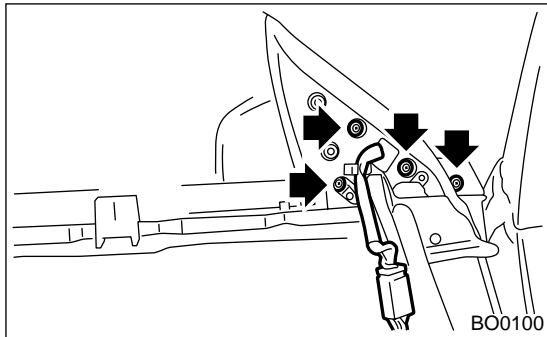

B: INSTALLATION

Install in the reverse order of removal.

C: INSPECTION

Check to ensure that rearview mirror moves properly when battery voltage is applied to terminals.

Mirror heater not-equipped model:

Switch position	Terminal connection
OFF	—
UP	4 (+) — 6 (-)
DOWN	6 (+) — 4 (-)
LEFT	5 (+) — 6 (-)
RIGHT	6 (+) — 5 (-)

If NG, replace the mirror.

Mirror heater equipped model:

Switch position	Terminal connection
OFF	—
UP	6 (+) — 8 (-)
DOWN	8 (+) — 6 (-)
LEFT	7 (+) — 8 (-)
RIGHT	8 (+) — 7 (-)

If NG, replace the mirror.

18. Outer Mirror

A: REPLACEMENT

- 1) Remove the door mirror assembly. <Ref. to GW-46, REMOVAL, Outer Mirror Assembly.>
- 2) Warm the area around the mirror holder with a hair drier until the edges of the mirror holder become soft (about 2 or 3 minutes with a 1,000 W drier.)
- 3) Use a flat-bladed screwdriver without sharp edges to lift the mirror out of the mirror holder. (Also remove the connector from the back of mirrors with heaters.)

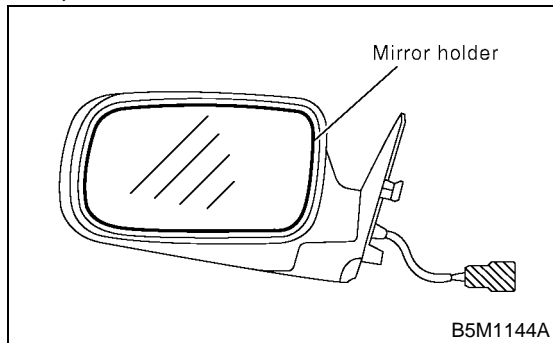

- 4) Warm the area around the mirror holder with a hair drier until the edges of the mirror holder become soft (about 2 or 3 minutes with a 1,000 W drier.)
- 5) Remove the backing of the new two-sided tape, and push the mirror in to install it.

CAUTION:

Unless the mirror holder is warmed sufficiently, the mirror holder edges may be damaged or the mirror cracked.

REMOTE CONTROL MIRROR SWITCH

GLASS/WINDOWS/MIRRORS

19.Remote Control Mirror Switch

B: INSTALLATION

Install in the reverse order of removal.

A: REMOVAL

- 1) Remove console cover.
- 2) Disconnect the connector.

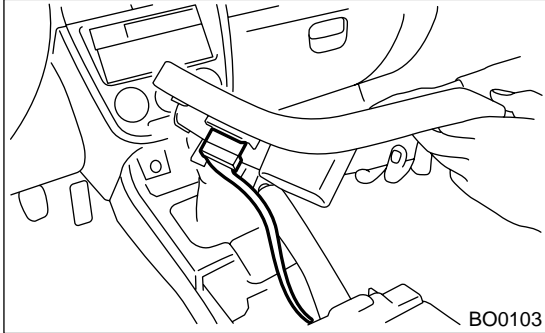

REMOTE CONTROL MIRROR SWITCH

GLASS/WINDOWS/MIRRORS

C: INSPECTION

Move rearview mirror switch to each position and check continuity between terminals.

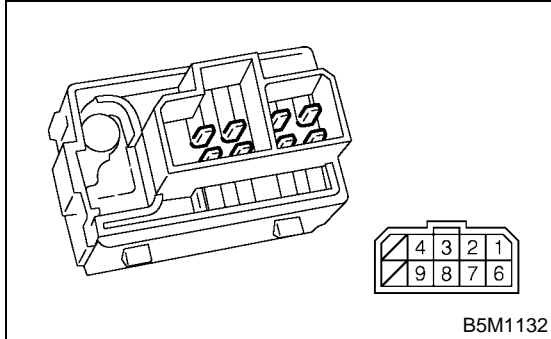

Change over switch left position:

Switch position	Tester connection	Specified condition
OFF	—	No continuity
UP	4 — 6, 2 — 1	Continuity
DOWN	6 — 2, 4 — 1	Continuity
LEFT	4 — 8, 2 — 1	Continuity
RIGHT	8 — 2, 4 — 1	Continuity

Change over switch right position:

Switch position	Tester connection	Specified condition
OFF	—	No continuity
UP	4 — 7, 2 — 1	Continuity
DOWN	7 — 2, 4 — 1	Continuity
LEFT	4 — 9, 2 — 1	Continuity
RIGHT	9 — 2, 4 — 1	Continuity

If NG, replace the switch.

BODY STRUCTURE

BS

Refer to G1831GE SUPPLEMENT for this section.

Page

