

BODY SECTION

This service manual has been prepared to provide SUBARU service personnel with the necessary information and data for the correct maintenance and repair of SUBARU vehicles.

This manual includes the procedures for maintenance, disassembling, reassembling, inspection and adjustment of components and diagnostics for guidance of experienced mechanics.

Please peruse and utilize this manual fully to ensure complete repair work for satisfying our customers by keeping their vehicle in optimum condition. When replacement of parts during repair work is needed, be sure to use SUBARU genuine parts.

All information, illustration and specifications contained in this manual are based on the latest product information available at the time of publication approval.

**HVAC SYSTEM
(HEATER, VENTILATOR AND A/C)** AC

**HVAC SYSTEM (AUTO A/C)
(DIAGNOSTICS)** AC

AIRBAG SYSTEM AB

AIRBAG SYSTEM (DIAGNOSTICS) AB

SEAT BELT SYSTEM SB

LIGHTING SYSTEM LI

WIPER AND WASHER SYSTEMS WW

ENTERTAINMENT ET

COMMUNICATION SYSTEM COM

GLASS/WINDOWS/MIRRORS GW

BODY STRUCTURE BS

INSTRUMENTATION/DRIVER INFO IDI

SEATS SE

SECURITY AND LOCKS SL

IMMOBILIZER (DIAGNOSTICS) IM

**SUNROOF/T-TOP/CONVERTIBLE TOP
(SUNROOF)** SR

EXTERIOR/INTERIOR TRIM EI

BODY SECTION

EXTERIOR BODY PANELS

EB

CRUISE CONTROL SYSTEM

CC

**CRUISE CONTROL SYSTEM
(DIAGNOSTICS)**

CC

HVAC SYSTEM (AUTO A/C) (DIAGNOSTICS)

AC

	Page
1. Basic Diagnostic Procedure	2
2. General Description	3
3. Electrical Components Location.....	6
4. A/C Control Module I/O Signal	8
5. Diagnostics Chart for Diagnosis System.....	18
6. Diagnostics for A/C System Failure	22
7. Diagnostic Procedure for Actuators	30
8. Diagnostic Procedure for Sensors	36
9. Symptom Related Diagnostic.....	46

BASIC DIAGNOSTIC PROCEDURE

HVAC SYSTEM (AUTO A/C) (DIAGNOSTICS)

1. Basic Diagnostic Procedure

A: PROCEDURE

Step	Check	Yes	No
1 START INSPECTIONS. 1)Perform pre-inspection. 2)Perform self-diagnosis. <Ref. to AC-18, SELF-DIAGNOSIS MODE, Diagnostics Chart for Diagnosis System.>	Dose self-diagnosis operate?	Go to step 2.	<Ref. to AC-22, A/C AND/OR SELF-DIAGNOSIS SYSTEMS DO NOT OPERATE, Diagnostics for A/C System Failure.>
2 CONFIRM MALFUNCTION PART. Confirm malfunction part with self-diagnosis.	Can the malfunction part be confirmed?	Repair the malfunction part according to each diagnostics chart.	Go to step 3.
3 CHECK COMPARTMENT TEMPERATURE. 1)Turn A/C switch ON. 2)Set temperature at maximum cold position. 3)Check compartment temperature changes.	Is the compartment temperature changed?	Go to step 4.	<Ref. to AC-26, COMPARTMENT TEMPERATURE IS NOT CHANGED OR A/C SYSTEM DOES NOT RESPOND QUICKLY, Diagnostics for A/C System Failure.>
4 CHECK A/C SYSTEM RESPONSE. Change the temperature setting, and check response of A/C system.	Dose A/C system respond quickly?	A/C system is OK.	<Ref. to AC-26, COMPARTMENT TEMPERATURE IS NOT CHANGED OR A/C SYSTEM DOES NOT RESPOND QUICKLY, Diagnostics for A/C System Failure.>

GENERAL DESCRIPTION

HVAC SYSTEM (AUTO A/C) (DIAGNOSTICS)

2. General Description

A: CAUTION

- 1) Never connect the battery in reverse polarity.
 - The Auto A/C control module will be destroyed instantly.
- 2) Do not disconnect the battery terminals while the engine is running.
 - A large counter electro motive force will be generated in the alternator, and this voltage may damage electronic parts such as A/C control module.
- 3) Before disconnecting the connectors of each sensor and the A/C control module, be sure to turn off the ignition switch.
 - Otherwise, the Auto A/C control module may be damaged.
- 4) Every Auto A/C-related part is a precision part. Do not drop them.
- 5) Airbag system wiring harness is routed near the A/C control panel (A/C control module) and junction box.

CAUTION:

- All Airbag system wiring harness and connectors are colored yellow. Do not use electrical test equipment on these circuits.
- Be careful not to damage Airbag system wiring harness when servicing the A/C control panel (A/C control module) and junction box.

B: INSPECTION

Before performing diagnosis, check the following items which might affect engine problems.

1. BATTERY

- 1) Measure battery voltage and specific gravity of electrolyte.

Standard voltage: 12 V

Specific gravity: Above 1.260

- 2) Check the condition of the fuses for A/C, heater and other fuses.
- 3) Check the condition of the harnesses and harness connectors connection.

2. ASPIRATOR HOSE

- 1) Make sure that the aspirator hose is securely connected to the heater unit by inserting a hand from the driver's compartment and secure as necessary.
- 2) Turn ignition switch to ON and push "A/C" switch.
- 3) Turn temperature control dial to maximum hot position.
- 4) Turn air flow control dial to "DEF" position.
- 5) Turn fan speed control dial to 4TH position.
- 6) Firmly hold a thin thread (b) in front of the in-vehicle sensor suction port (a) for the auto A/C control unit and check that the thread moves towards the port indicating that air is being sucked into the port.

NOTE:

- Ensure the thread does not get sucked into the port.
- Hold the thread approximately 5 mm (0.02 in) away from the port when the suction force is not very strong.

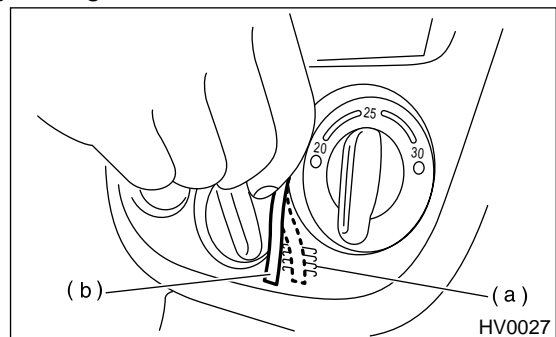

GENERAL DESCRIPTION

HVAC SYSTEM (AUTO A/C) (DIAGNOSTICS)

7) If the thread does not move at all, remove the auto A/C control unit <Ref. to AC-26, REMOVAL, Control Unit.> and check for improper connection of the aspirator hose (a) and auto A/C control unit and secure as necessary.

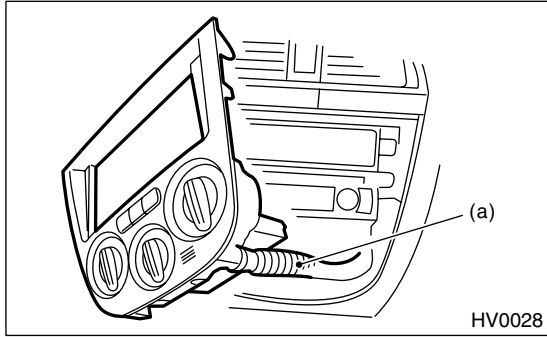

3. REFRIGERANT LINE

Check contact for refrigerant line (A).

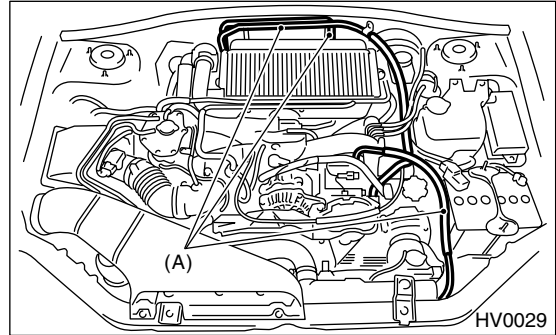

4. CONTROL LINKAGE

- 1) Check state of mode door linkage.
- 2) Check state of air mix door linkage.
- 3) Check state of intake door linkage.

GENERAL DESCRIPTION

HVAC SYSTEM (AUTO A/C) (DIAGNOSTICS)

5. CONTROL SWITCHES

Start and warm up engine completely.

1) Inspection using switches.

No.	Point to check	Switch operation	Judgement standard
1	Fan speed control dial	OFF position	A/C switch LED goes out. • Fan speed: OFF • Compressor: OFF
		Fan speed control dial 1st → 2nd → 3rd → 4th	Fan speed changes 1st → 2nd → 3rd → 4th
2	Fan speed control dial and temperature control dial	A. Fan speed control dial auto position. B. Temperature control dial maximum cold position	• Outlet air: Cool • Fan speed: 4th • Compressor: ON
		C. Turn temperature control dial from maximum cold position to maximum hot position gradually.	• Outlet air: Cool → Hot • Fan speed: AUTO • Compressor: ON
		D. Temperature control dial maximum hot position	• Outlet air: Hot • Fan speed: 4th • Compressor: ON
3	Air flow control dial	Air flow control dial VENT → BI-LEVEL → HEAT → DEF/HEAT → DEF	Air flow outlet changes from VENT → BI-LEVEL → HEAT → DEF/HEAT → DEF.
4	FRESH/RECIRC switch	FRESH/RECIRC switch ON	Changes from RECIRC → FRESH, or FRESH → RECIRC.

2) Compressor operation inspection

No.	Point to check	Switch operation	Judgement standard
1	Compressor	A. A/C switch ON B. Fan speed control dial 1st-4th	Compressor: ON

3) Illumination control inspection

No.	Point to check	Switch operation	Judgement standard
1	Illumination	Lighting switch ON	Illumination light illuminates.

ELECTRICAL COMPONENTS LOCATION

HVAC SYSTEM (AUTO A/C) (DIAGNOSTICS)

3. Electrical Components Location

A: LOCATION

1. ENGINE COMPARTMENT

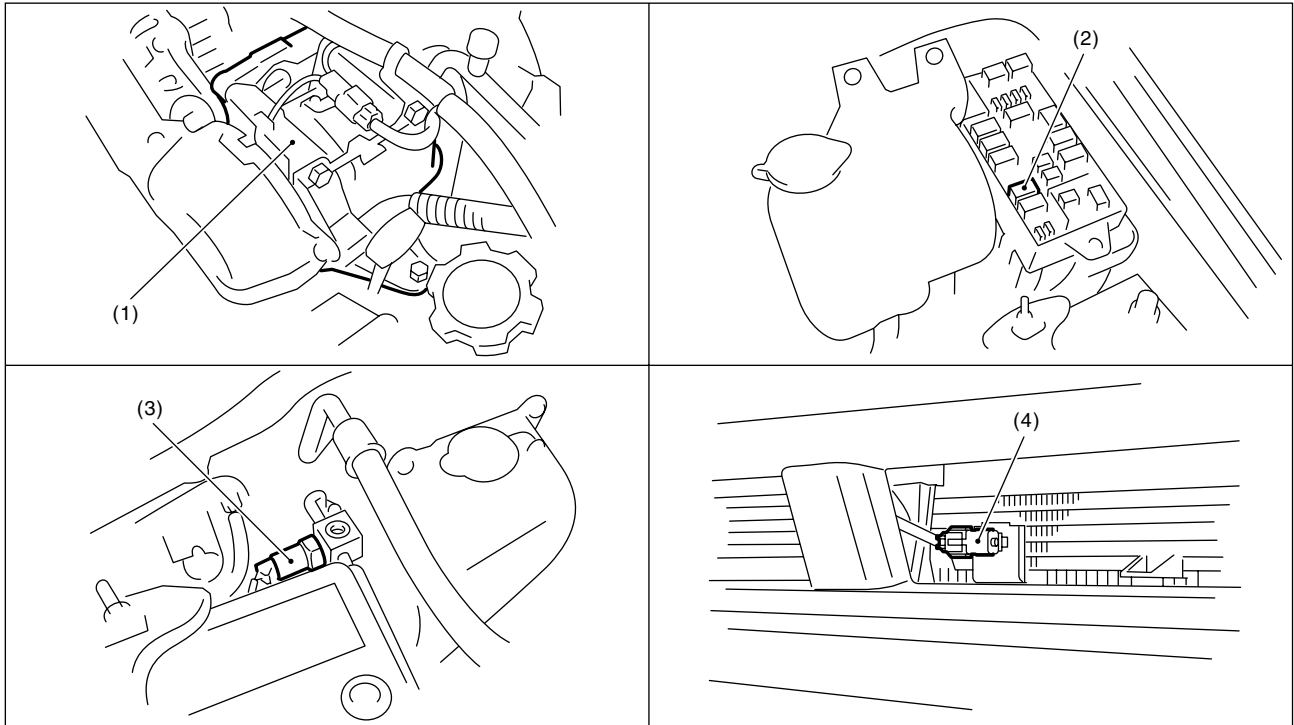
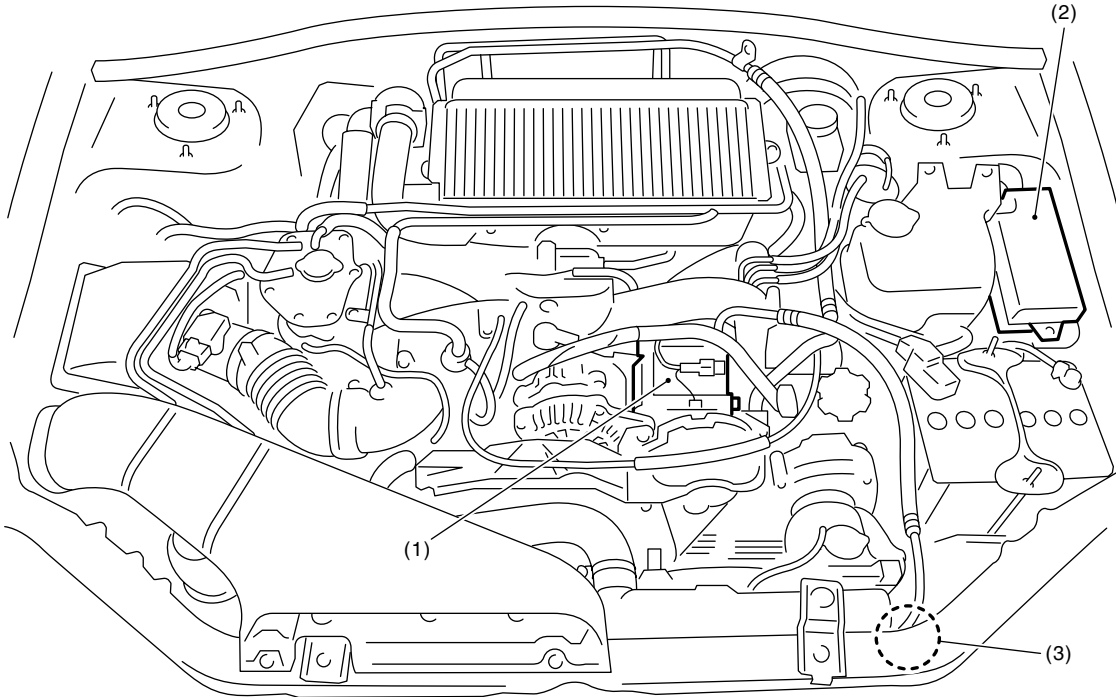

HV0030

- (1) A/C compressor
- (2) A/C relay

- (3) Pressure switch
- (4) Ambient sensor

ELECTRICAL COMPONENTS LOCATION

HVAC SYSTEM (AUTO A/C) (DIAGNOSTICS)

2. PASSENGER COMPARTMENT

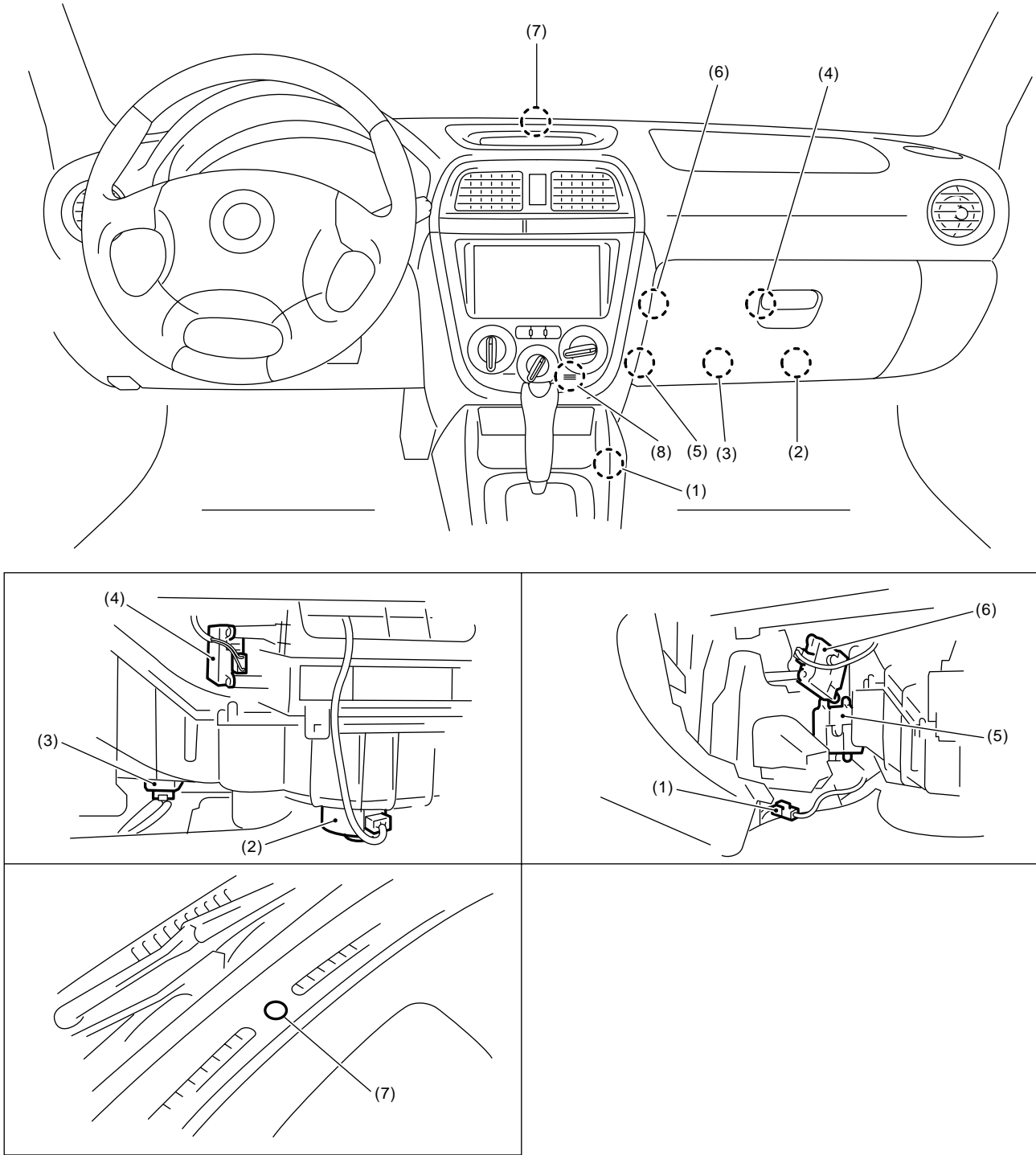

HV0031

- (1) Evaporator sensor
- (2) Blower motor
- (3) Blower motor resistor

- (4) Intake door actuator
- (5) Air mix door actuator
- (6) Mode door actuator

- (7) Sunload sensor
- (8) In-vehicle sensor
(built-in Auto A/C control module)

A/C CONTROL MODULE I/O SIGNAL

HVAC SYSTEM (AUTO A/C) (DIAGNOSTICS)

4. A/C Control Module I/O Signal

A: ELECTRICAL SPECIFICATION

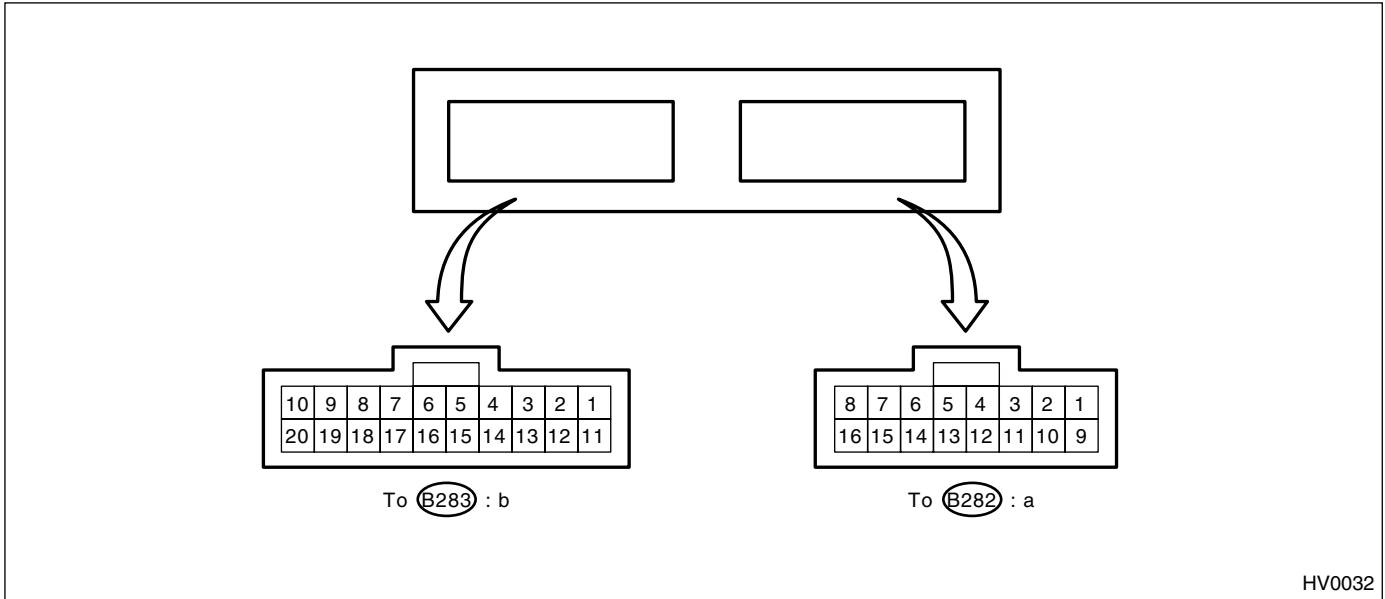

Content	Connector & Terminal No.	Signal (V)
Battery power supply (Memory back-up)	b1—b12	Battery voltage, 13 — 14 (engine running)
IGN power supply	a8—b12	Battery voltage (ignition switch ON), 13 — 14 (engine running)
ACC power supply (OFF: ignition in START or diagnosis system reset)	b2—b12	Battery voltage, 0 (engine cranking), Battery voltage (during engine starts)
A/C control module ground circuit	b12—body	0 (ignition switch ON) — circuit constantly grounded
Sensor ground circuit	b17—body	0 (ignition switch ON) — continuity exists
Ambient sensor	b9—b17	Approx. 3.3 (disconnect connector, and ignition switch ON)
Evaporator sensor	b7—b17	
Thermometer	b15—b12	
Sunload sensor	b16—b17	Approx. 4.2 (disconnect connector, and ignition switch ON)
Air mix door actuator	b5—b1	Battery voltage (ignition switch ON)
Air mix door actuator P.B.R.	a4—b17	Approx. 5.5
Mode door actuator	b6—b17	Battery voltage (ignition switch ON)
Mode door actuator P.B.R.	a12—b17	Approx. 5.5
Intake door FRS voltage	a15—a7	Battery voltage (CIRC switch OFF)
Intake door CIRC voltage	a7—a15	Battery voltage (CIRC switch ON)
Blower fan relay	b14—body	Battery voltage (ignition switch ON)
A/C relay	b3—b12	0 (ignition and A/C switches ON) Battery voltage (A/C switch OFF)
Illumination control signal	b10—b20	Battery voltage (ignition and lighting switches ON)
Rear defogger	a13—b12	0 (IGN ON, R Def SW ON)

A/C CONTROL MODULE I/O SIGNAL

HVAC SYSTEM (AUTO A/C) (DIAGNOSTICS)

B: SCHEMATIC

1. AIR CONDITIONER AUTO A/C LHD MODEL

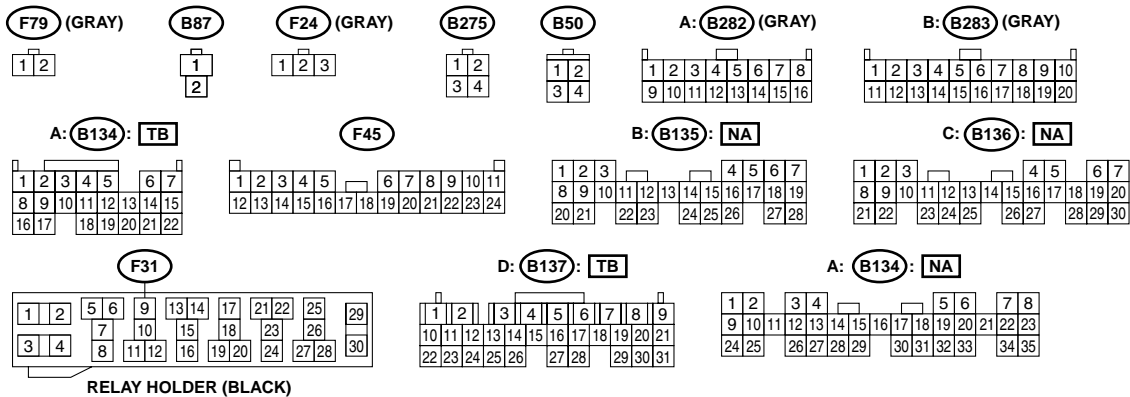
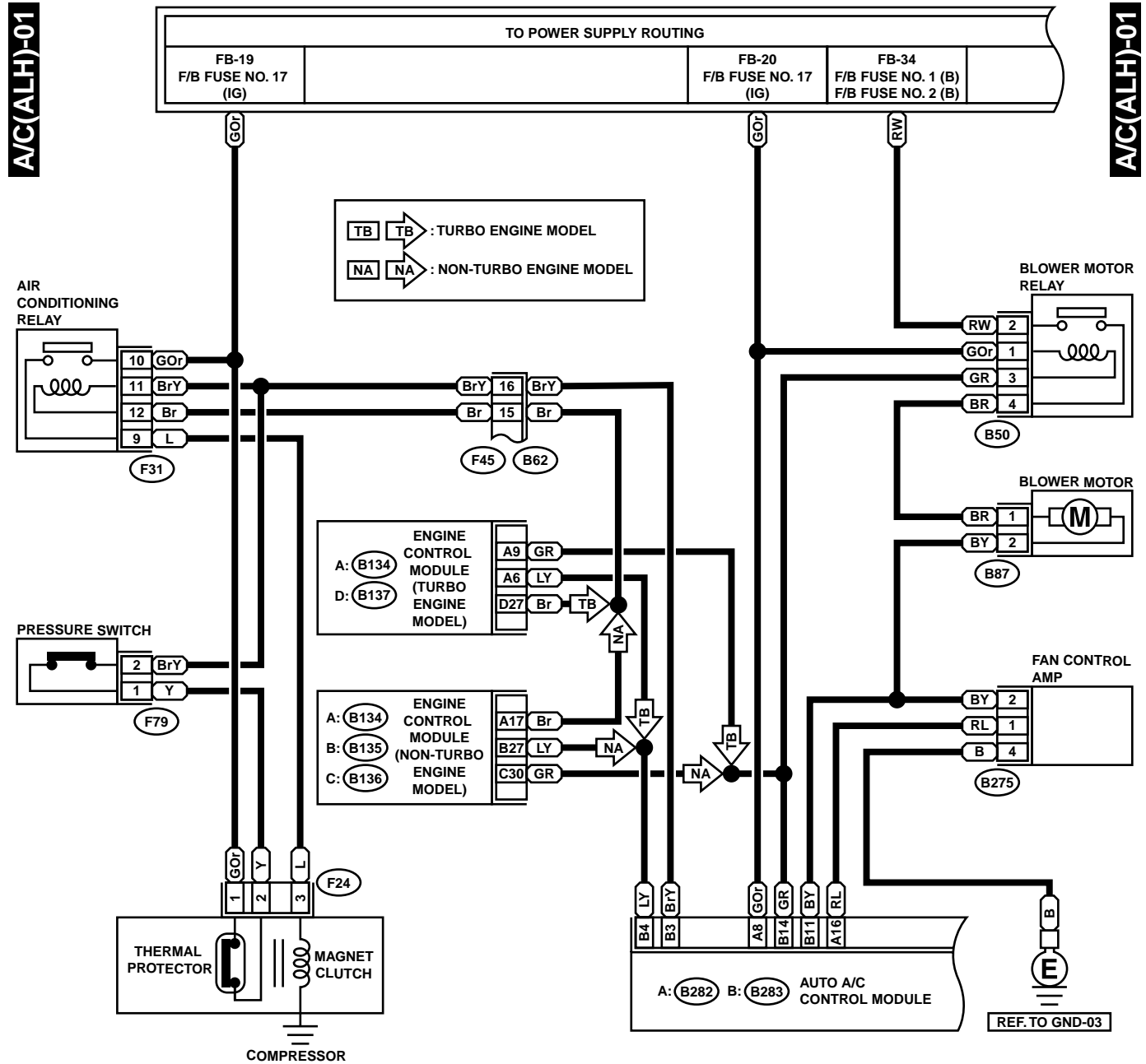

GL46-20A

A/C CONTROL MODULE I/O SIGNAL

HVAC SYSTEM (AUTO A/C) (DIAGNOSTICS)

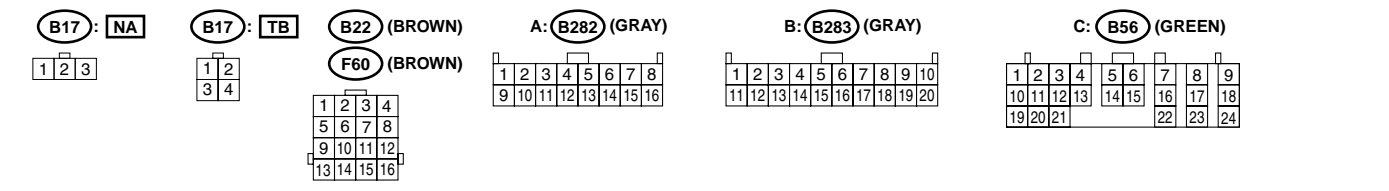
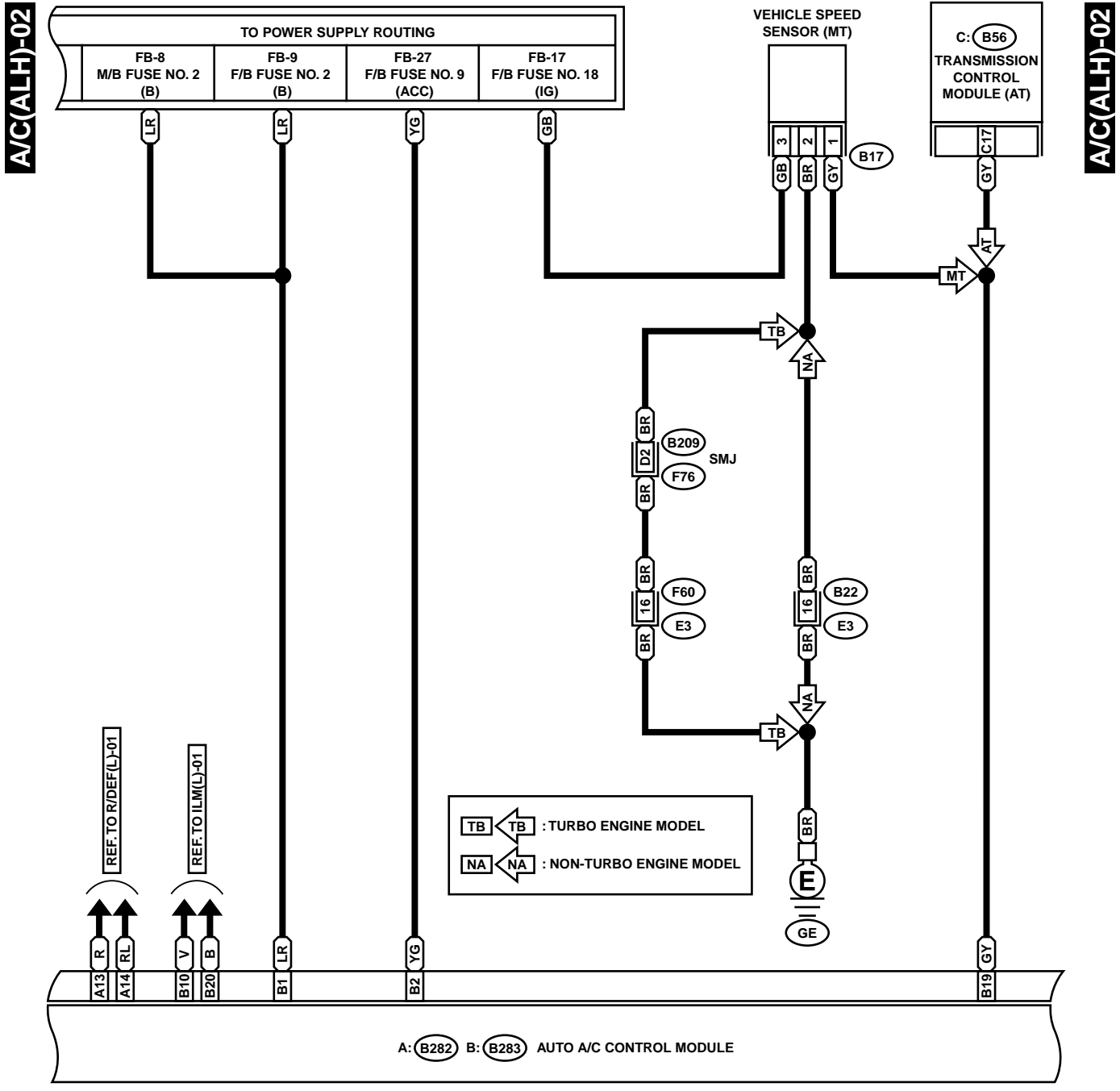

GL46-20B

A/C CONTROL MODULE I/O SIGNAL

HVAC SYSTEM (AUTO A/C) (DIAGNOSTICS)

A/C(ALH)-03

A/C(ALH)-03

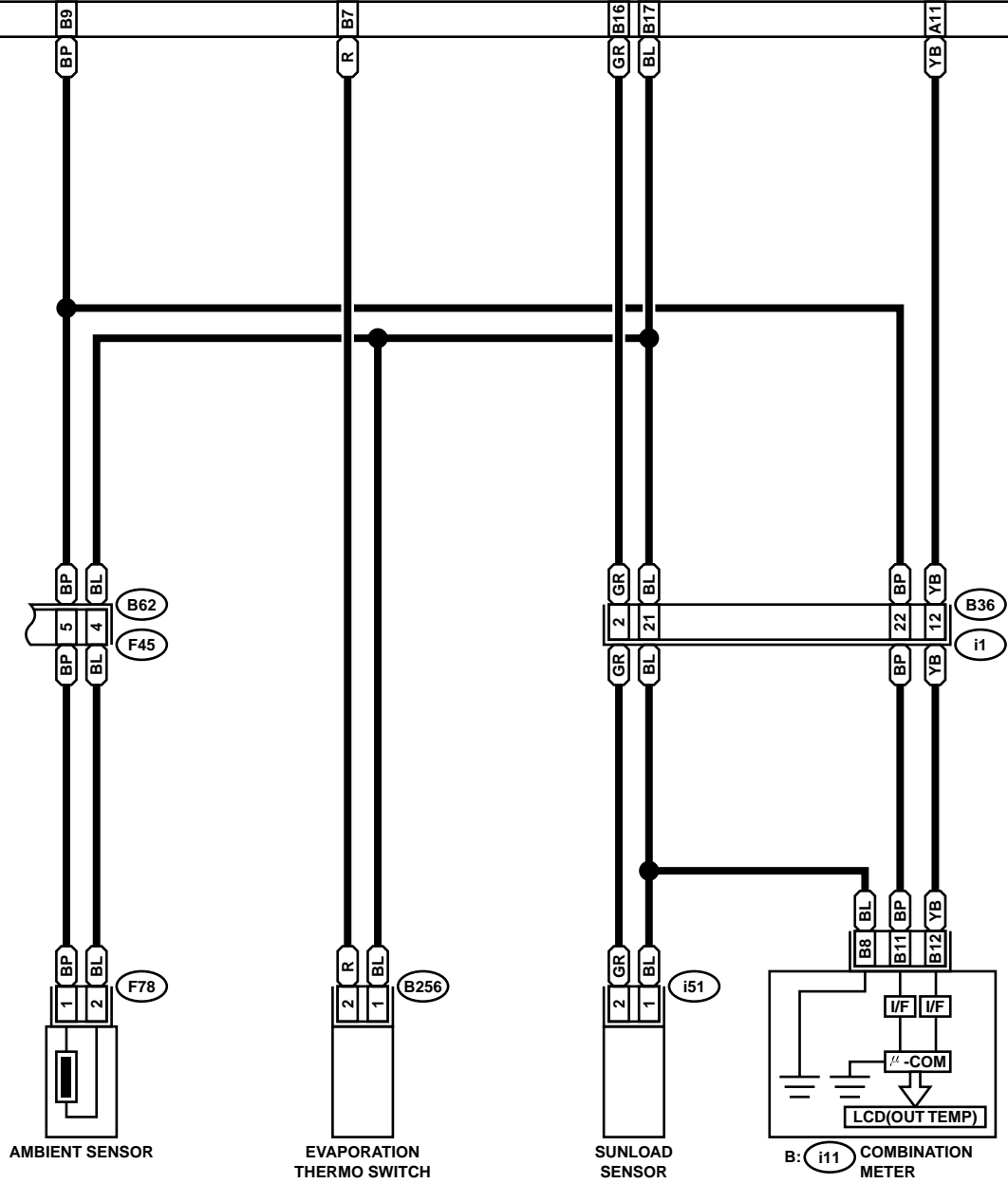
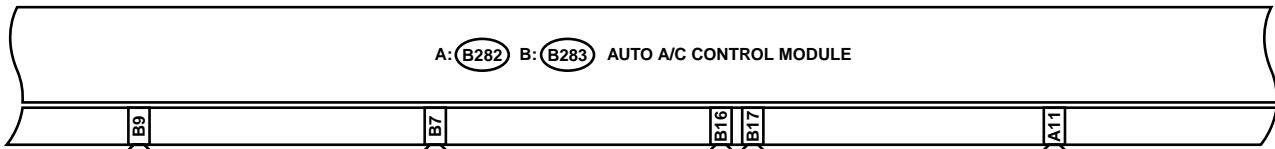

AMBIENT SENSOR

EVAPORATION THERMO SWITCH

SUNLOAD SENSOR

B: i11 COMBINATION METER

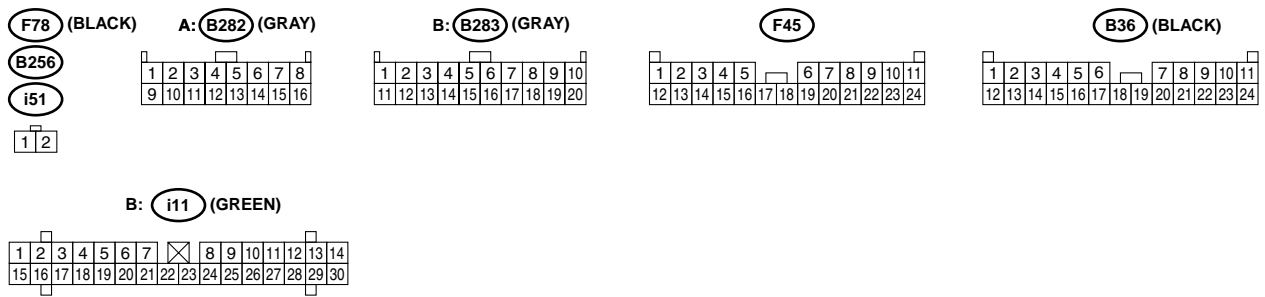

A/C CONTROL MODULE I/O SIGNAL

HVAC SYSTEM (AUTO A/C) (DIAGNOSTICS)

A/C(ALH)-04

A/C(ALH)-04

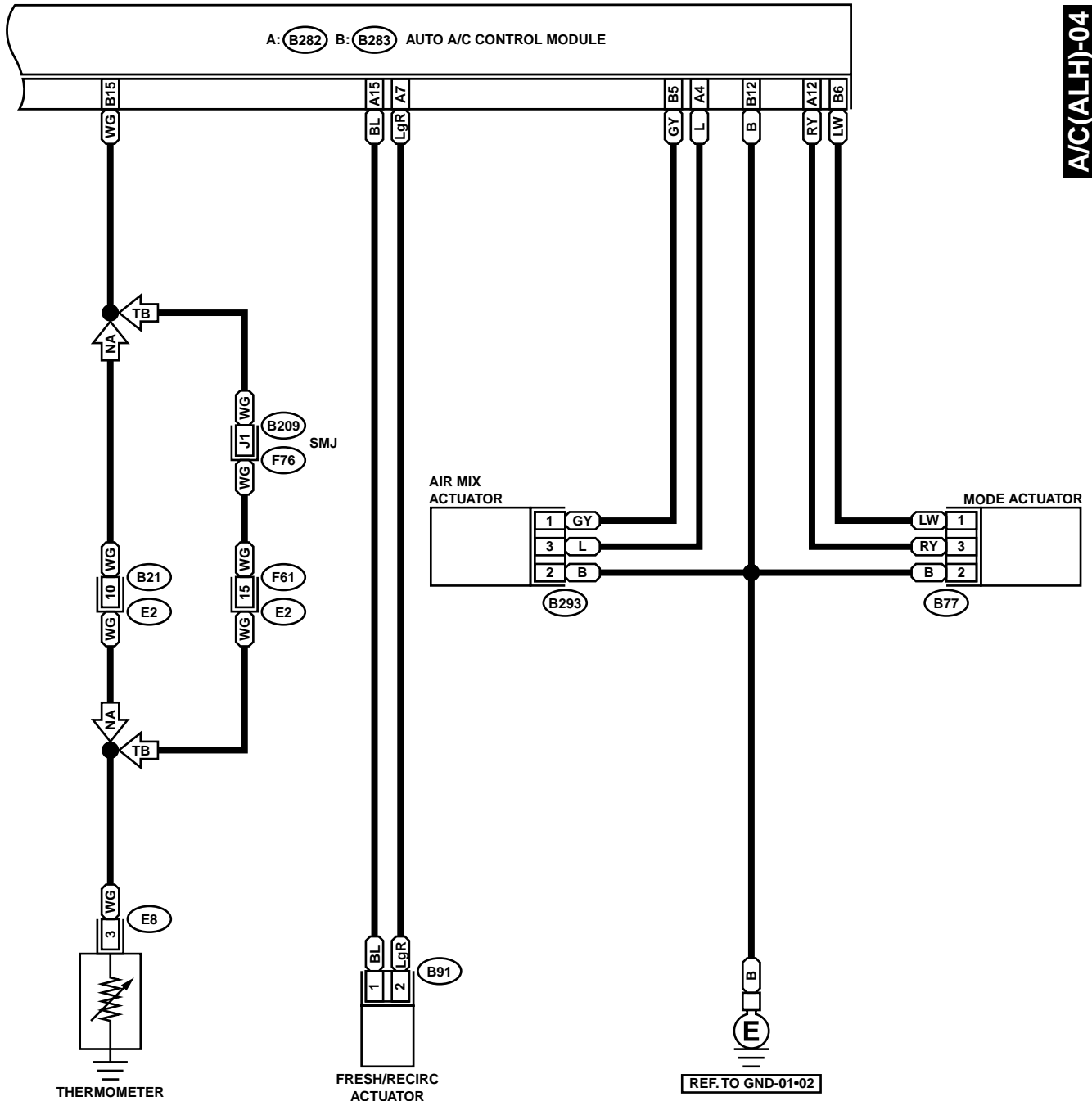

(B77)

(E8) (LIGHT GRAY)

(B91) (BLACK)

A: (B282) (GRAY)

B: (B283) (GRAY)

(F61) (BLACK)

(B293)

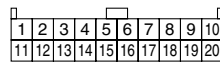
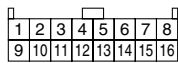

(B21) (LIGHT GRAY)

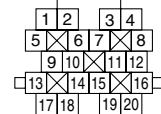

GL46-20D

A/C CONTROL MODULE I/O SIGNAL

HVAC SYSTEM (AUTO A/C) (DIAGNOSTICS)

2. AIR CONDITIONER AUTO A/C RHD MODEL

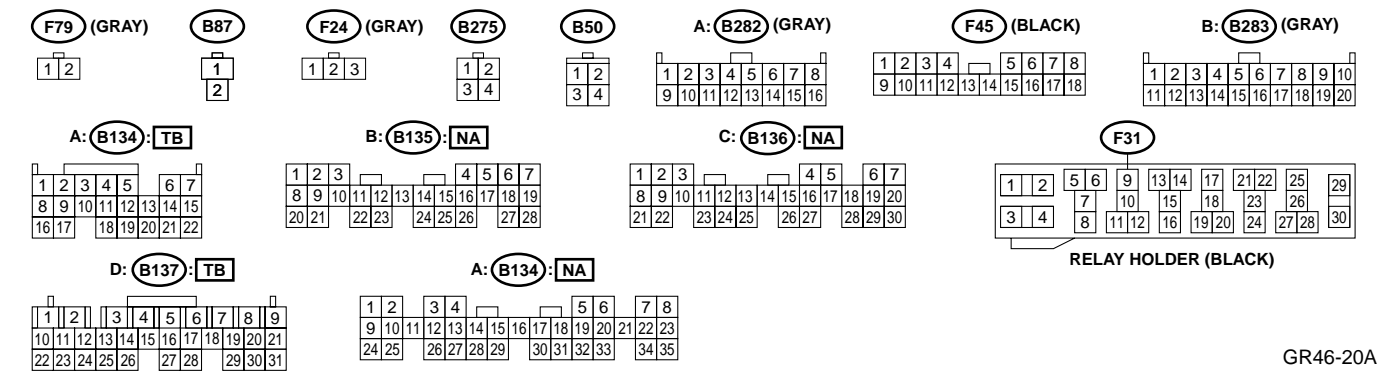
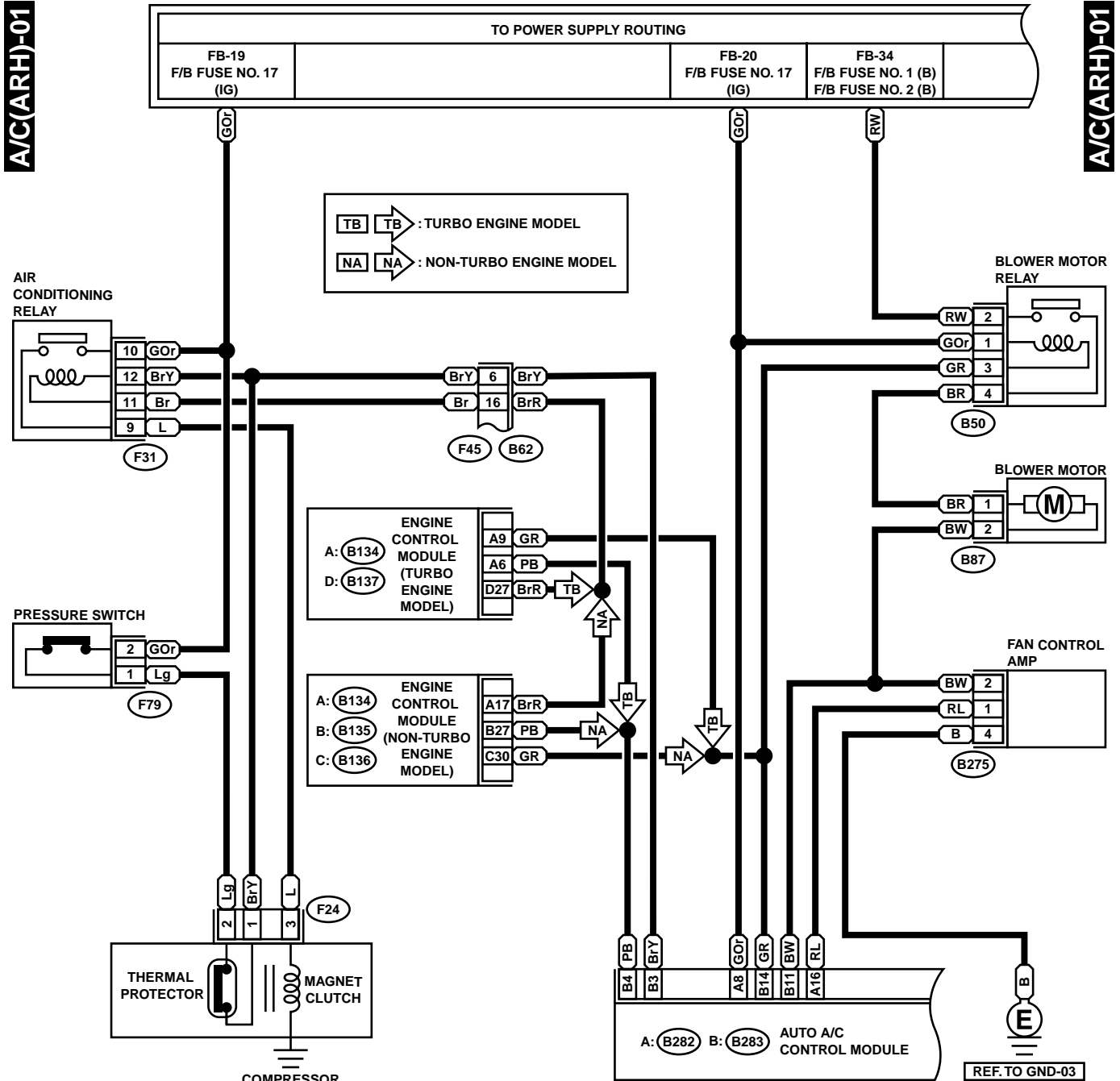

GR46-20A

A/C CONTROL MODULE I/O SIGNAL

HVAC SYSTEM (AUTO A/C) (DIAGNOSTICS)

A/C(ARH)-02

A/C(ARH)-02

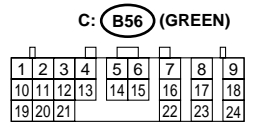
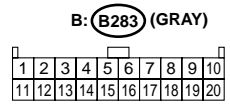
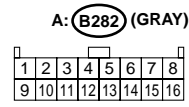
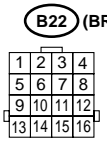
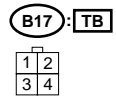
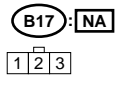
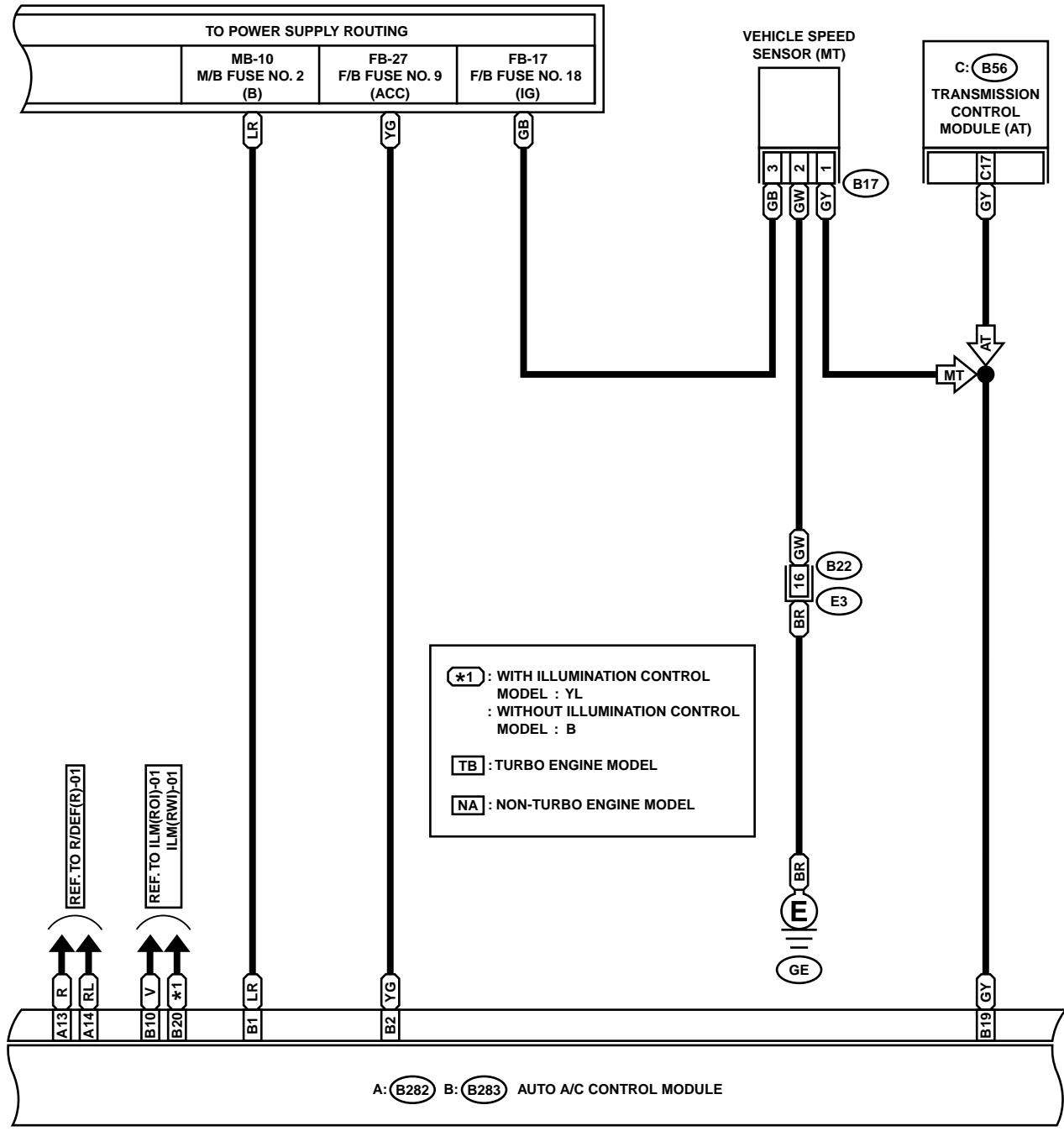

A/C CONTROL MODULE I/O SIGNAL

HVAC SYSTEM (AUTO A/C) (DIAGNOSTICS)

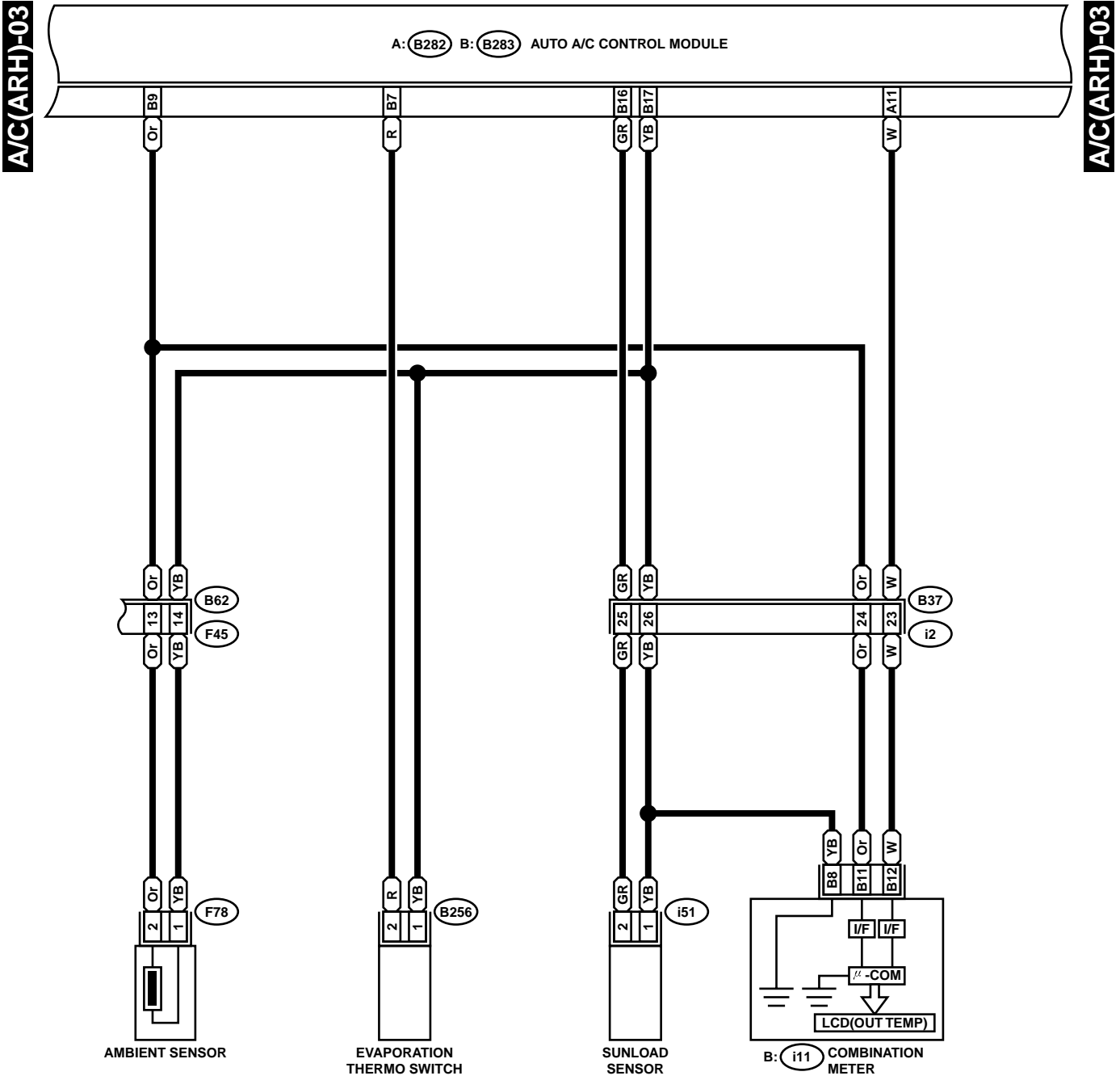

F78 (BLACK)

B256

i51

1 2

A: B282 (GRAY)

1	2	3	4	5	6	7	8
9	10	11	12	13	14	15	16

F45 (BLACK)

1	2	3	4	5	6	7	8		
9	10	11	12	13	14	15	16	17	18

B: B283 (GRAY)

1	2	3	4	5	6	7	8	9	10
11	12	13	14	15	16	17	18	19	20

B: i11 (GREEN)

1	2	3	4	5	6	7	8	9	10	11	12	13	14		
15	16	17	18	19	20	21	22	23	24	25	26	27	28	29	30

i2

1	2	3	4	5	6	7	8	9			
10	11	12	13	14	15	16	17	18	19	20	21
22	23	24	25	26	27	28	29	30	31	32	

A/C CONTROL MODULE I/O SIGNAL

HVAC SYSTEM (AUTO A/C) (DIAGNOSTICS)

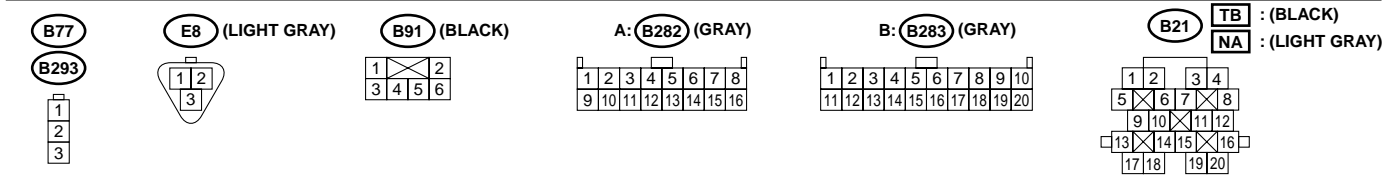
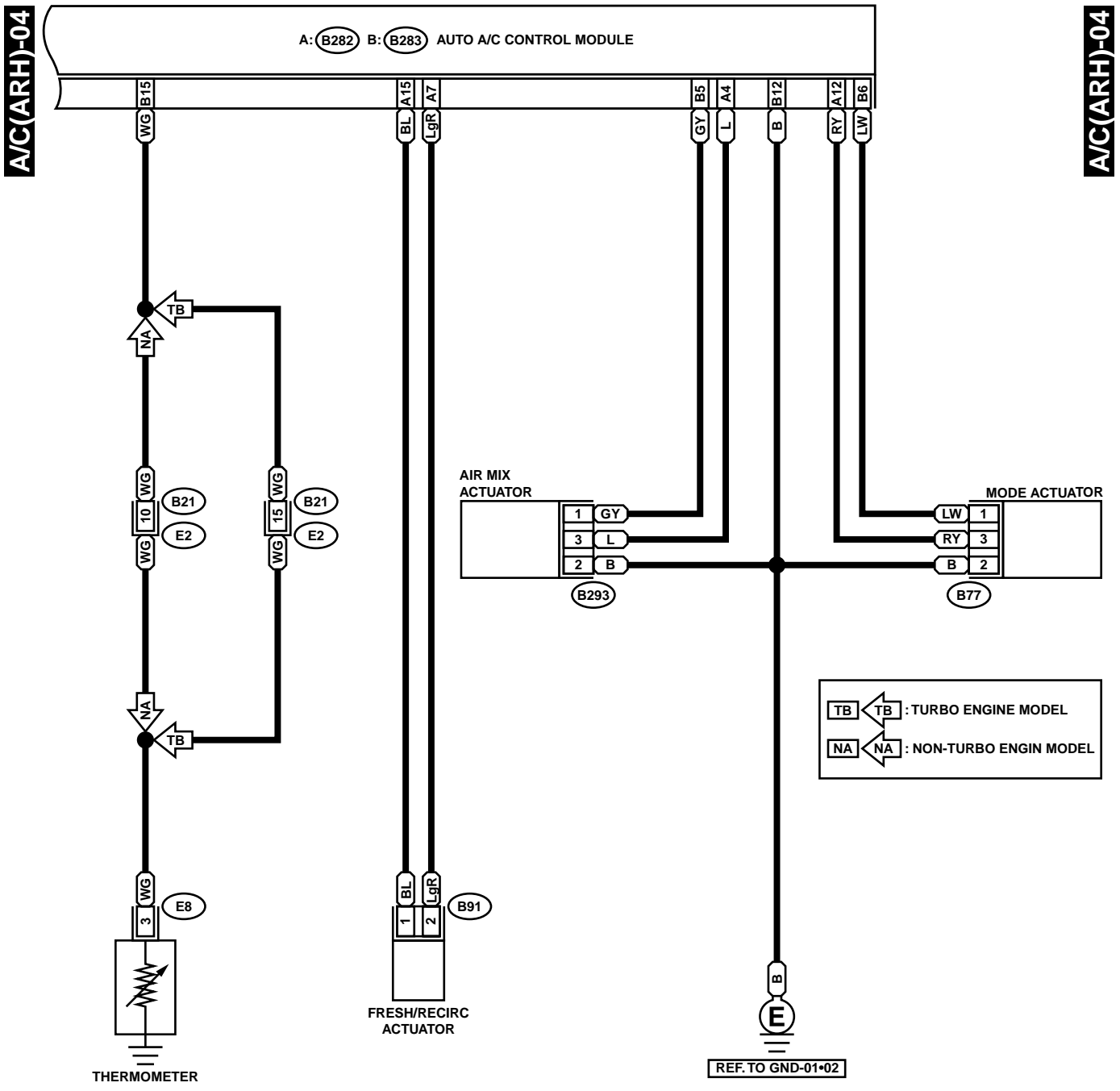

GR46-20D

A/C CONTROL MODULE I/O SIGNAL

HVAC SYSTEM (AUTO A/C) (DIAGNOSTICS)

DIAGNOSTICS CHART FOR DIAGNOSIS SYSTEM

HVAC SYSTEM (AUTO A/C) (DIAGNOSTICS)

5. Diagnostics Chart for Diagnosis System

A: SELF-DIAGNOSIS MODE

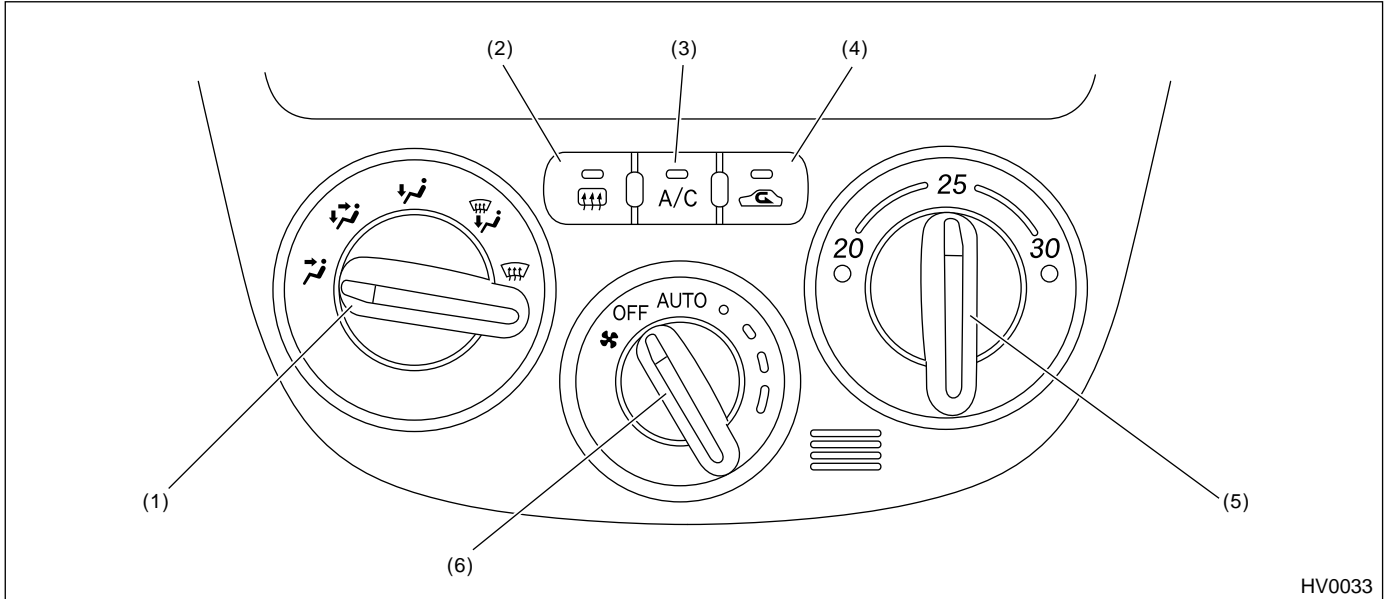

HV0033

- | | | |
|---------------------------------|-------------------------|------------------------------|
| (1) Air flow control dial | (3) A/C switch | (5) Temperature control dial |
| (2) Rear window defogger switch | (4) FRESH/RECIRC switch | (6) Fan speed control dial |

Step	Check	Yes	No
1 SELECT CONTROL PANEL TO SELF-DIAGNOSIS MODE. 1) Turn fan speed control dial to OFF position. 2) Start engine and press rear window defogger switch for at least 5 seconds. The rear window defogger switch must be pressed within 10 seconds after starting engine.	Does the self-diagnosis mode operate?	Go to step 2.	<Ref. to AC-22, A/C AND/OR SELF-DIAGNOSIS SYSTEMS DO NOT OPERATE, Diagnostics for A/C System Failure.>
2 CHECK LED ILLUMINATION. Make sure that all switch LED illuminate (RHD model) or blink (LHD model) on control panel.	Do all LED illuminate or blink?	Go to step 3.	Check the switch LED.
3 CHECK SENSORS MALFUNCTION. 1) Turn fan speed control dial to AUTO position. 2) If system has the trouble for each sensor, rear window defogger switch LED is turned off. 3) If system has no trouble, rear window defogger switch LED is illuminated.	Does rear window defogger switch LED illuminate?	Go to step 5.	Go to step 4.
4 CONFIRM MALFUNCTIONING SENSOR. 1) Turn fan speed control dial to 1st position. 2) Turn air flow control dial to each mode position, check each switch LED illumination according to sensor check table. <Ref. to AC-20, SENSOR CHECK TABLE, SELF-DIAGNOSIS MODE, Diagnostics Chart for Diagnosis System.>	Do FRESH/RECIRC and A/C switch LED illuminate when turning the dial to each mode position?	Go to step 5.	Repair malfunctioning sensor. <Ref. to AC-36, Diagnostic Procedure for Sensors.>

DIAGNOSTICS CHART FOR DIAGNOSIS SYSTEM

HVAC SYSTEM (AUTO A/C) (DIAGNOSTICS)

Step	Check	Yes	No
5 CHECK MODE DOOR POSITION SIGNAL. 1) Turn fan speed control dial to 2nd position. 2) If system has the trouble for mode door position signal, rear window defogger switch LED is turned off. 3) If system has no trouble, rear window defogger switch LED is illuminated.	Does rear window defogger switch LED illuminate?	Go to step 6.	Check mode door actuator circuit. <Ref. to AC-32, MODE DOOR ACTUATOR, Diagnostic Procedure for Actuators.>
6 CHECK BLOWER FAN OPERATION. 1) Turn fan speed control dial to 3rd position. 2) Turn temperature control dial, check that blower fan speed changes depending on set temperature.	Does blower fan speed change?	Go to step 7.	Check blower motor circuit. <Ref. to AC-24, BLOWER MOTOR IS NOT ROTATED, Diagnostics for A/C System Failure.>
7 CHECK OPERATION OF EACH ACTUATOR, BLOWER FAN AND COMPRESSOR CLUTCH. 1) Turn fan speed control dial to 4TH position. 2) Select operating mode by turning air flow control dial. 3) Check the operation of each mode according to operating mode table. <Ref. to AC-20, OPERATING MODE TABLE, SELF-DIAGNOSIS MODE, Diagnostics Chart for Diagnosis System.> •Air inlet: •Air outlet: •Air mix door: •Blower fan: •A/C compressor:	Does the operation of each mode match to the operating mode table?	Push A/C switch or turn ignition switch OFF, and finish the self-diagnosis.	Repair the malfunction part according to each diagnostics chart.

DIAGNOSTICS CHART FOR DIAGNOSIS SYSTEM

HVAC SYSTEM (AUTO A/C) (DIAGNOSTICS)

1. SENSOR CHECK TABLE

NOTE:

When the sunload sensor is checked indoors or in the shade, open circuit might be indicated. Always check the sunload sensor at a place where sun shines directly on it.

Air flow control dial position	Checked sensor	No trouble	Short circuit	Open circuit
VENT	Ambient sensor	A/C switch LED and FRESH/RECIRC switch LED illuminate	A/C switch LED illuminate	FRESH/RECIRC switch LED illuminate
BI-LEVEL	In-vehicle sensor	A/C switch LED and FRESH/RECIRC switch LED illuminate	A/C switch LED illuminate	FRESH/RECIRC switch LED illuminate
HEAT	Evaporator sensor	A/C switch LED and FRESH/RECIRC switch LED illuminate	A/C switch LED illuminate	FRESH/RECIRC switch LED illuminate
DEF/HEAT	Sunload sensor	A/C switch LED and FRESH/RECIRC switch LED illuminate	A/C switch LED illuminate	FRESH/RECIRC switch LED illuminate
DEF	Air mix door motor (Potential balance resistor)	A/C switch LED and FRESH/RECIRC switch LED illuminate	A/C switch LED illuminate	

2. OPERATING MODE TABLE

Operation	Air flow control dial position				
	VENT	BI-LEVEL	HEAT	DEF/HEAT	DEF
Air outlet	VENT	BI-LEVEL	HEAT	DEF/HEAT	DEF
Air inlet	RECIRC	RECIRC	RECIRC	FRESH	FRESH
Air mix door	FULL COOL	FULL COOL	FULL HOT	FULL HOT	FULL COOL
Blower fan	5V	5V	8V	10V	Power supply voltage
A/C compressor	ON	OFF	OFF	ON	ON

DIAGNOSTICS CHART FOR DIAGNOSIS SYSTEM

HVAC SYSTEM (AUTO A/C) (DIAGNOSTICS)

DIAGNOSTICS FOR A/C SYSTEM FAILURE

HVAC SYSTEM (AUTO A/C) (DIAGNOSTICS)

6. Diagnostics for A/C System Failure

A: A/C AND/OR SELF-DIAGNOSIS SYSTEMS DO NOT OPERATE

TROUBLE SYMPTOM:

- "Set" temperature is not indicated on display, switch LEDs are faulty and switches do not operate.
- Self-diagnosis system does not operate.

WIRING DIAGRAM:

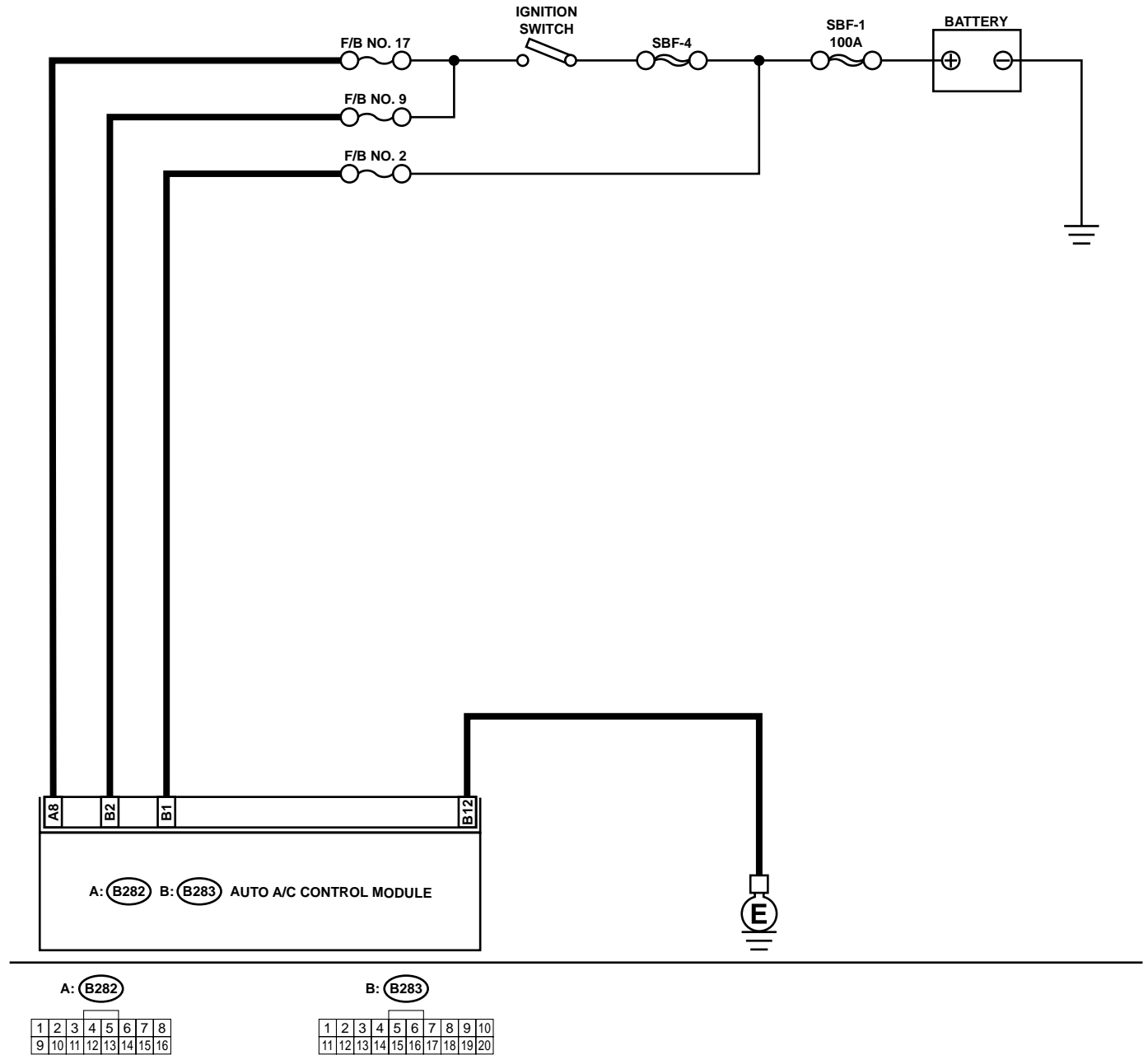

HV0034

DIAGNOSTICS FOR A/C SYSTEM FAILURE

HVAC SYSTEM (AUTO A/C) (DIAGNOSTICS)

Step	Check	Yes	No
1 CHECK FUSE. 1) Turn ignition switch to OFF. 2) Remove fuse No. 2 from main fuse box. 3) Check condition of fuse.	Is the fuse blown-out?	Replace fuse.	Go to step 2.
2 CHECK FUSE. 1) Turn ignition switch to OFF. 2) Remove fuses No. 9 and No. 17 from fuse & relay box. 3) Check condition of fuse.	Is the fuse blown-out?	Replace fuse.	Go to step 3.
3 CHECK A/C CONTROL MODULE POWER CIRCUIT. 1) Pull out A/C control module connector. 2) Measure voltage between A/C control module connector terminal and chassis ground when turning ignition switch to OFF. Connector & terminal (B283) No. 1 (+) — Chassis ground (-):	Is the voltage more than 10 V?	Go to step 4.	Repair short circuit in harness for power supply line.
4 CHECK A/C CONTROL MODULE POWER CIRCUIT. Measure voltage between A/C control module connector terminal and chassis ground when turning ignition switch to ACC. Connector & terminal (B283) No. 2 (+) — Chassis ground (-):	Is the voltage more than 10 V?	Go to step 5.	Repair short circuit in harness for power supply line.
5 CHECK A/C CONTROL MODULE POWER CIRCUIT. Measure voltage between A/C control module connector terminal and chassis ground when turning ignition switch to ON. Connector & terminal (B282) No. 8 (+) — Chassis ground (-):	Is the voltage more than 10 V?	Go to step 6.	Repair short circuit in harness for power supply line.
6 CHECK A/C CONTROL MODULE GROUND CIRCUIT. Measure resistance of harness between A/C control module and chassis ground. Connector & terminal (B283) No. 12 — Chassis ground:	Is the resistance less than 5 Ω ?	Go to step 7.	Repair short circuit in harness for ground line.
7 CHECK POOR CONTACT. Check poor contact in A/C control module.	Is there poor contact in A/C control module?	Repair poor contact in A/C control module.	Contact with your Subaru distributor.

DIAGNOSTICS FOR A/C SYSTEM FAILURE

HVAC SYSTEM (AUTO A/C) (DIAGNOSTICS)

B: BLOWER MOTOR IS NOT ROTATED

TROUBLE SYMPTOM:

- Blower motor is not rotated.
- Blower motor is not rotated in "HI".

WIRING DIAGRAM:

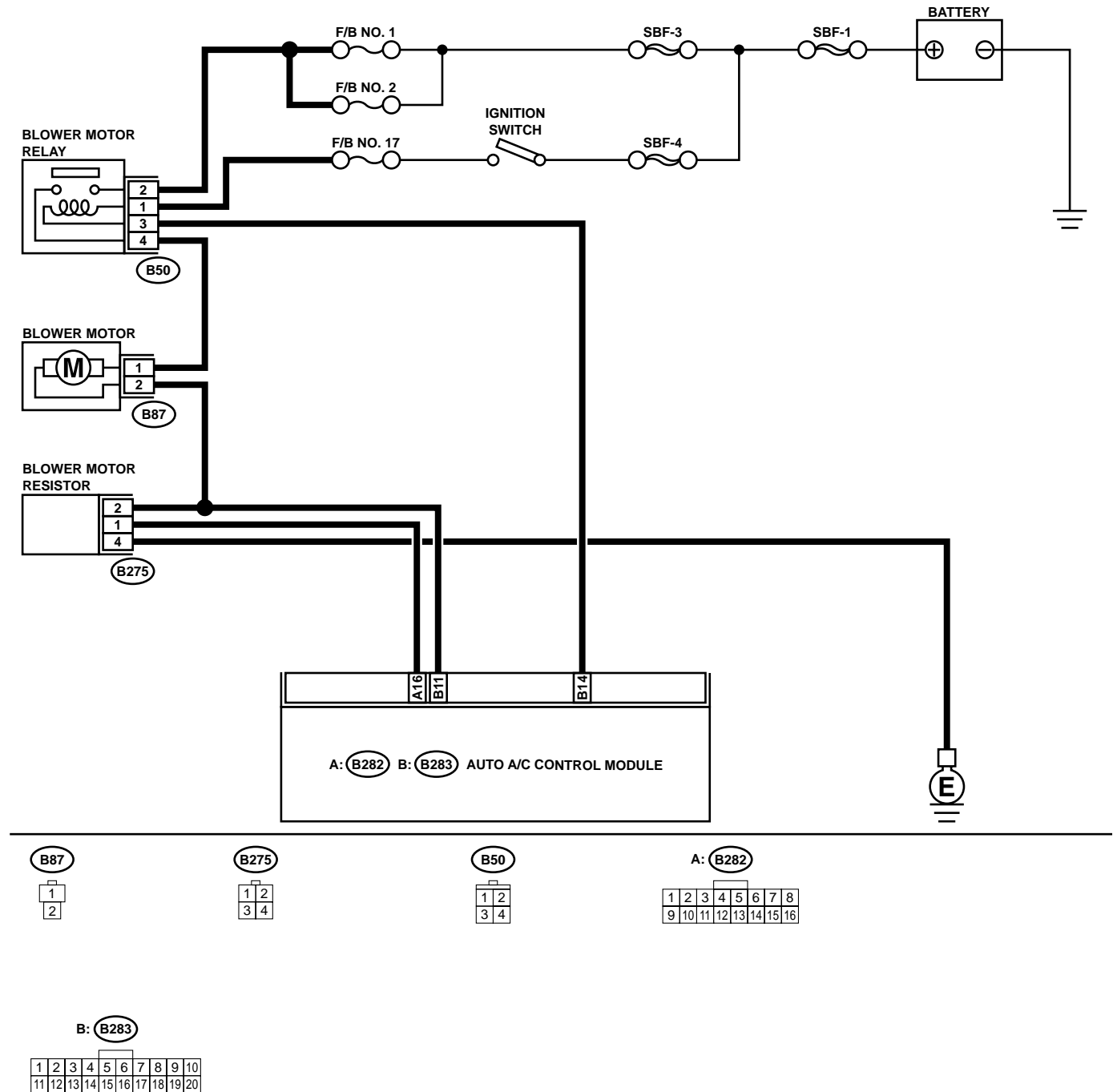

HV0035

DIAGNOSTICS FOR A/C SYSTEM FAILURE

HVAC SYSTEM (AUTO A/C) (DIAGNOSTICS)

Step	Check	Yes	No
1 CHECK FUSE. 1) Remove No. 1, No. 2 and No. 17 fuses in fuse & relay box. 2) Check condition of fuses.	Are any of the fuses blown-out?	Replace fuse.	Go to step 2.
2 CHECK POWER SUPPLY TO BLOWER FAN MOTOR. 1) Turn ignition switch to ON. 2) Turn blower switch to ON. 3) Measure voltage between blower fan motor and chassis ground. Connector & terminal (B87) No. 1 (+) — Chassis ground (-):	Is the voltage more than 10 V?	Go to step 3.	Repair open circuit in harness for blower fan motor power supply line.
3 CHECK BLOWER FAN MOTOR RELAY. 1) Turn ignition switch to OFF. 2) Remove blower fan motor relay. 3) Connect battery to No. 1 and No. 3 terminals of blower fan motor connector. 4) Measure resistance between No. 2 and No. 4 terminals. Terminals: No. 2 — No. 4	Is the resistance less than 1 Ω ?	Go to step 4.	Replace blower fan motor relay.
4 CHECK BLOWER FAN MOTOR. 1) Disconnect connector from blower fan motor. 2) Connect battery to connector terminals of blower fan motor. 3) Make sure that blower fan motor is operated.	Does the blower fan motor operate?	Go to step 5.	Replace blower fan motor.
5 CHECK POOR CONTACT. Check poor contact in A/C control module.	Is there poor contact in A/C control module?	Repair poor contact in A/C control module.	Contact with your Subaru distributor.

DIAGNOSTICS FOR A/C SYSTEM FAILURE

HVAC SYSTEM (AUTO A/C) (DIAGNOSTICS)

C: COMPARTMENT TEMPERATURE IS NOT CHANGED OR A/C SYSTEM DOES NOT RESPOND QUICKLY

WIRING DIAGRAM FOR TURBO ENGINE MODEL:

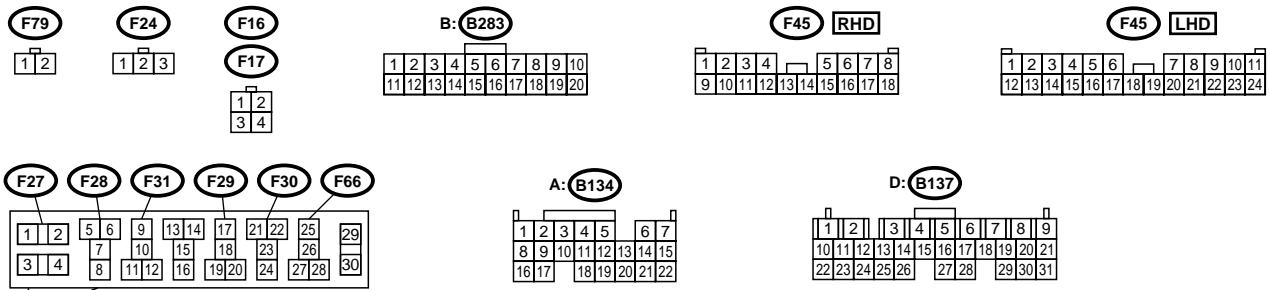
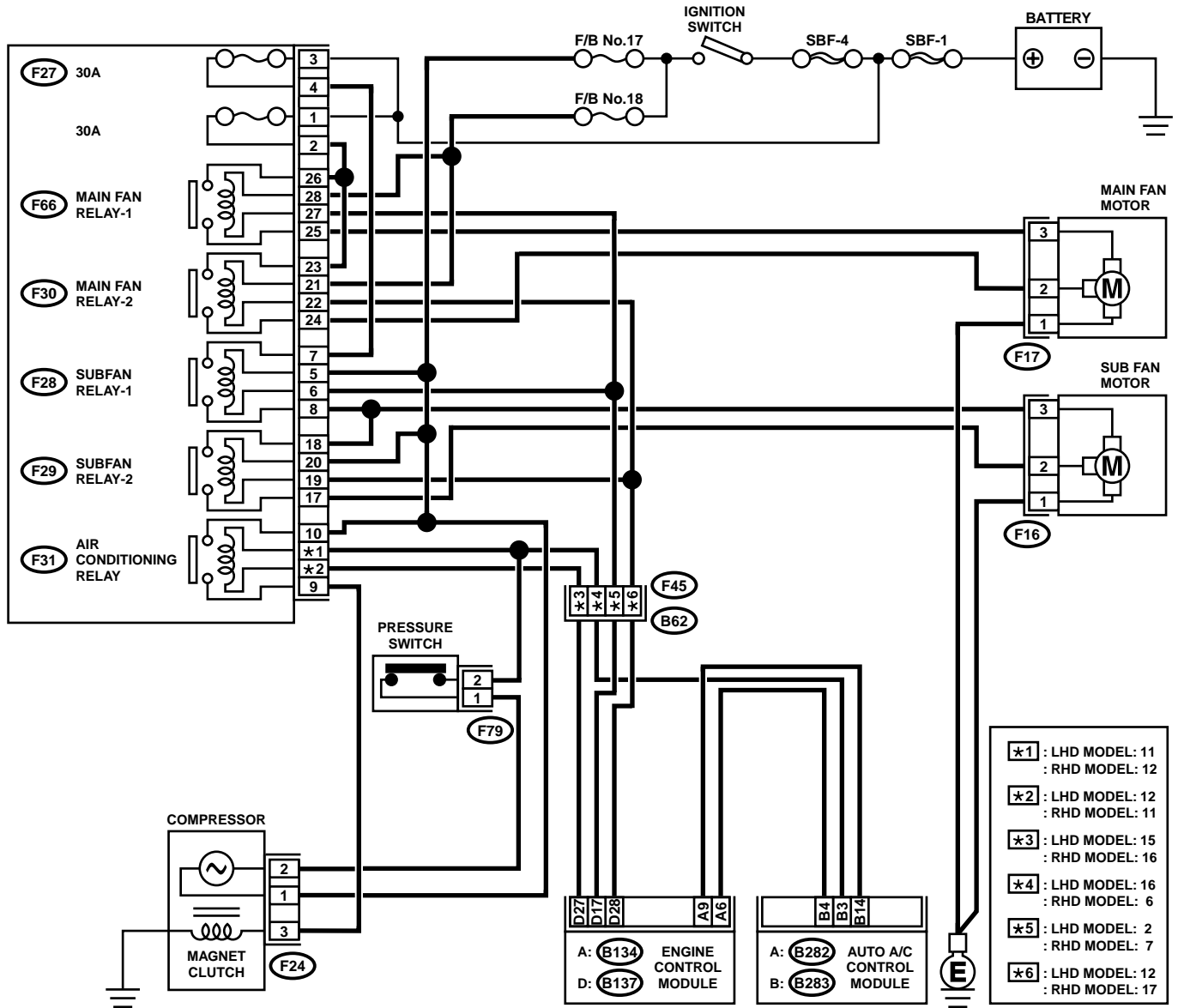

DIAGNOSTICS FOR A/C SYSTEM FAILURE

HVAC SYSTEM (AUTO A/C) (DIAGNOSTICS)

WIRING DIAGRAM FOR NON-TURBO ENGINE MODEL:

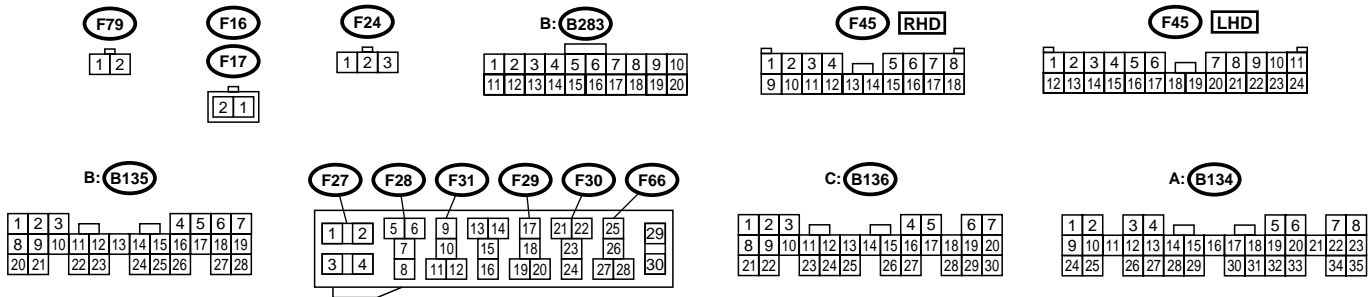
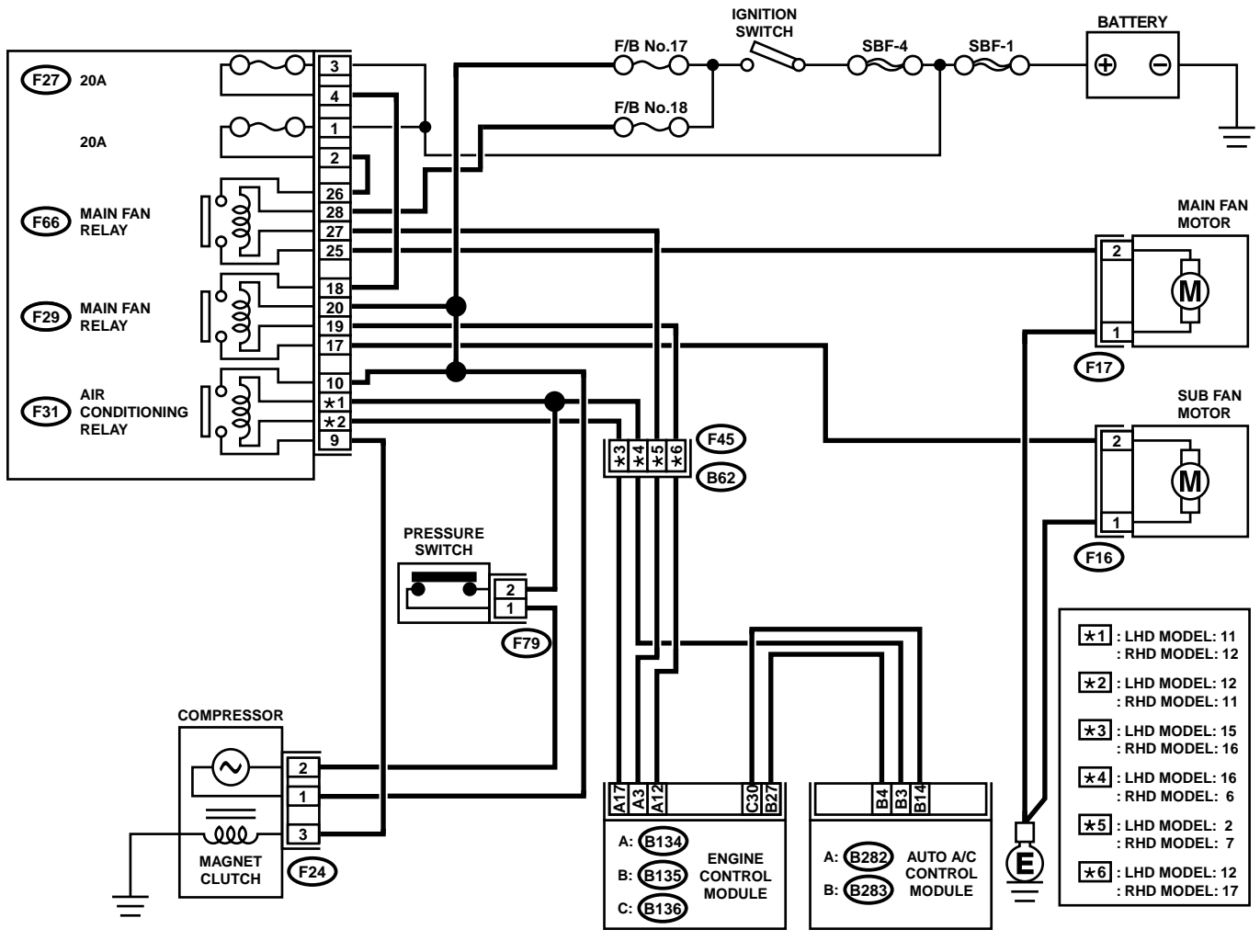

HV0037

DIAGNOSTICS FOR A/C SYSTEM FAILURE

HVAC SYSTEM (AUTO A/C) (DIAGNOSTICS)

Step	Check	Yes	No
1 CHECK FUSE. 1) Turn ignition switch to OFF. 2) Remove No. 2 fuse in main fuse box. 3) Check condition of fuse.	Is the fuse blown-out?	Replace fuse.	Go to step 2.
2 CHECK POWER SUPPLY TO MAGNET CLUTCH OF A/C COMPRESSOR. 1) Start the engine, and turn A/C switch to ON. 2) Set temperature control dial to maximum cold position. 3) Measure voltage between magnet clutch connector and chassis ground. Connector & terminal (F24) No. 3 (+) — Chassis ground (-):	Is the voltage more than 10 V?	Go to step 3.	Repair open circuit in harness for power supply line of the A/C compressor.
3 CHECK SIGNAL VOLTAGE TO A/C RELAY. 1) Turn ignition switch to ON. 2) Turn A/C switch to ON. 3) Measure signal voltage to A/C relay and chassis ground. Connector & terminal (F31) No. 9 (+) — Chassis ground (-):	Is the voltage more than 10 V?	Go to step 4.	Repair open circuit in harness for power supply line.
4 CHECK A/C RELAY. 1) Remove A/C relay in main fuse box. 2) Check A/C relay. <Ref. to AC-32, INSPECTION, Relay and Fuse.>	Is the operation of the relay OK?	Go to step 5.	Replace A/C relay.
5 CHECK OPERATION OF MAIN FAN MOTOR. 1) Start the engine. 2) Turn A/C switch to ON. 3) Check operation of main fan motor.	Does the radiator main fan operate?	Go to step 10.	Go to step 6.
6 CHECK POWER SUPPLY TO MAIN FAN MOTOR. CAUTION: Be careful not to overheat engine during repair. 1) Turn ignition switch to OFF. 2) Disconnect connector from main fan motor. 3) Start the engine, and warm it up until engine coolant temperature increases over 95°C (203°F). 4) Stop the engine and turn ignition switch to ON. 5) Measure voltage between main fan motor connector and chassis ground. Connector & terminal Turbo engine model: (F17) No. 2, 3 (+) — Chassis ground (-): Non-turbo engine model: (F17) No. 2 (+) — Chassis ground (-):	Is the voltage more than 10 V?	Go to step 7.	Repair open circuit in harness for power supply circuit.
7 CHECK GROUND CIRCUIT OF MAIN FAN MOTOR. 1) Turn ignition switch to OFF. 2) Measure resistance between main fan motor connector and chassis ground. Connector & terminal (F17) No. 1 — Chassis ground:	Is the resistance less than 1 Ω?	Go to step 8.	Repair open circuit in harness between main fan motor connector and chassis ground.
8 CHECK POOR CONTACT. Check poor contact in main fan motor connector.	Is there poor contact in main fan motor connector?	Repair poor contact in main fan motor connector.	Go to step 9.

DIAGNOSTICS FOR A/C SYSTEM FAILURE

HVAC SYSTEM (AUTO A/C) (DIAGNOSTICS)

Step	Check	Yes	No
9 CHECK MAIN FAN MOTOR. Connect battery positive (+) terminal to terminal No. 2 and 3 (turbo engine model) or 2 (non-turbo engine model), and negative (-) terminal to terminal No. 1 of main fan motor connector.	Does the main fan rotate?	Repair poor contact in main fan motor connector.	Replace main fan motor with a new one.
10 CHECK OPERATION OF SUB FAN MOTOR. Check operation of sub fan motor.	Does the radiator sub fan operate?	Go to step 15.	Go to step 11.
11 CHECK POWER SUPPLY TO SUB FAN MOTOR. CAUTION: Be careful not to overheat engine during repair. 1) Turn ignition switch to OFF. 2) Disconnect connector from sub fan motor. 3) Start the engine, and warm it up until engine coolant temperature increases over 100°C (212°F). 4) Stop the engine and turn ignition switch to ON. 5) Measure voltage between sub fan motor connector and chassis ground. Connector & terminal Turbo engine model: (F16) No. 2, 3 (+) — Chassis ground (-): Non-turbo engine model: (F16) No. 2 (+) — Chassis ground (-):	Is the voltage more than 10 V?	Go to step 12.	Repair open circuit in harness for power supply circuit.
12 CHECK GROUND CIRCUIT OF SUB FAN MOTOR. 1) Turn ignition switch to OFF. 2) Measure resistance between sub fan motor connector and chassis ground. Connector & terminal (F16) No. 1 — Chassis ground:	Is the resistance less than 1 Ω?	Go to step 13.	Repair open circuit in harness between sub fan motor connector and chassis ground.
13 CHECK POOR CONTACT. Check poor contact in sub fan motor connector.	Is there poor contact in sub fan motor connector?	Repair poor contact in sub fan motor connector.	Go to step 14.
14 CHECK SUB FAN MOTOR. Connect battery positive (+) terminal to terminal No. 2 and 3 (turbo engine model) or 2 (non-turbo engine model), and negative (-) terminal to terminal No. 1 of sub fan motor connector.	Does the sub fan rotate?	Repair poor contact in sub fan motor connector.	Replace sub fan motor with a new one.
15 CHECK EACH SENSOR AND POTENTIAL METER. Check the sensors and potential meter for proper operation using the self-diagnostic function. <Ref. to AC-18, Diagnostics Chart for Diagnosis System.>	Is the operation of each sensor and potential meter normal?	Go to step 16.	Check the sensor and circuit. <Ref. to AC-36, Diagnostic Procedure for Sensors.>
16 CHECK CONNECTION OF ASPIRATOR DUCT. Make sure that the connection of aspirator duct is correct.	Is the connection of aspirator duct correct?	Repair aspirator duct connection.	Go to step 17.
17 CHECK EACH ACTUATOR. Check the actuators for proper operation using the self-diagnostic function. <Ref. to AC-18, Diagnostics Chart for Diagnosis System.>	Is the operation of each actuator normal?	Go to step 18.	Check the actuator and circuit. <Ref. to AC-30, Diagnostic Procedure for Actuators.>
18 CHECK POOR CONTACT. Check poor contact in A/C control module.	Is there poor contact in A/C control module?	Repair poor contact in A/C control module.	Contact with your Subaru distributor.

DIAGNOSTIC PROCEDURE FOR ACTUATORS

HVAC SYSTEM (AUTO A/C) (DIAGNOSTICS)

7. Diagnostic Procedure for Actuators

A: INTAKE DOOR ACTUATOR

TRUBLE SYMPTOM:

FRESH/RECIRC mode is not changed.

WIRING DIAGRAM:

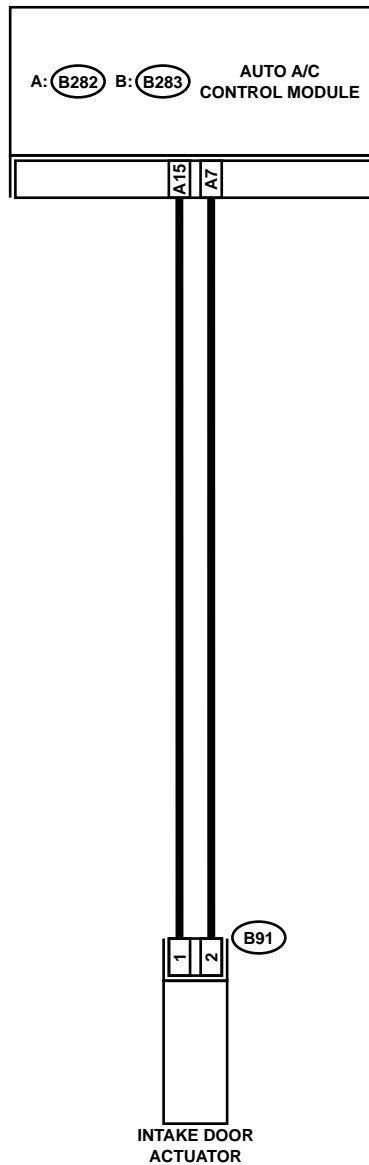

B91

A: B282

1	2
3	4

1	2	3	4	5	6	7	8
9	10	11	12	13	14	15	16

HV0038

DIAGNOSTIC PROCEDURE FOR ACTUATORS

HVAC SYSTEM (AUTO A/C) (DIAGNOSTICS)

Step	Check	Yes	No
1 CHECK FUSE. 1) Remove No. 17 fuse in fuse & relay box. 2) Check condition of fuse.	Is the fuse blown-out?	Replace fuse.	Go to step 2.
2 CHECK SIGNAL VOLTAGE. 1) Change air intake to RECIRC by pushing FRESH/RECIRC switch. 2) Measure voltage between A/C control module and chassis ground. Connector & terminal (B282) No. 15 (+) — Chassis ground (-):	Is the voltage less than 1 V?	Go to step 3.	Repair short circuit in harness for power supply line.
3 CHECK SIGNAL VOLTAGE. 1) Change air intake to FRESH with pushing FRESH/RECIRC switch. 2) Measure voltage between A/C control module and chassis ground. Connector & terminal (B282) No. 7 (+) — Chassis ground (-):	Is the voltage less than 1 V?	Go to step 4.	Repair short circuit in harness for power supply line.
4 CHECK HARNESS CONNECTOR BETWEEN A/C CONTROL MODULE AND FRESH/RECIRC ACTUATOR. 1) Turn ignition switch to OFF. 2) Disconnect connector from A/C control module and intake door actuator. 3) Measure resistance of harness between A/C control module and intake door actuator. Connector & terminal: (B282) No. 15 — (B91) No. 1	Is the resistance less than 1 Ω ?	Go to step 5.	Repair open circuit in harness between A/C control module and intake door actuator.
5 CHECK HARNESS CONNECTOR BETWEEN A/C CONTROL MODULE AND FRESH/RECIRC ACTUATOR. Measure resistance of harness between A/C control module and intake door actuator. Connector & terminal: (B282) No. 7 — (B91) No. 2	Is the resistance less than 1 Ω ?	Go to step 6.	Repair open circuit in harness between A/C control module and intake door actuator.
6 CHECK POOR CONTACT. Check poor contact in A/C control module.	Is there poor contact in A/C control module?	Repair poor contact in A/C control module.	Contact with your Subaru distributor.

DIAGNOSTIC PROCEDURE FOR ACTUATORS

HVAC SYSTEM (AUTO A/C) (DIAGNOSTICS)

B: MODE DOOR ACTUATOR

TROUBLE SYMPTOM:

Air flow outlet is not changed.

WIRING DIAGRAM:

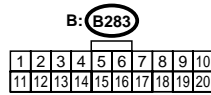
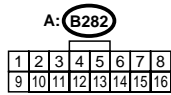
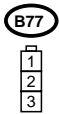
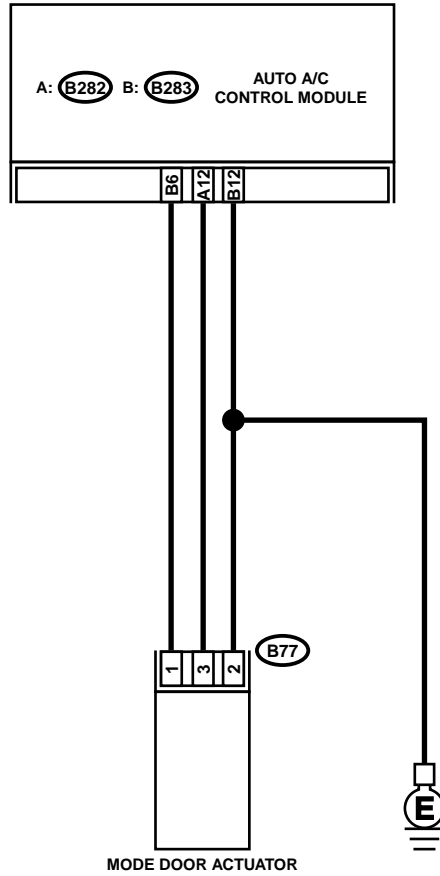

HV0039

DIAGNOSTIC PROCEDURE FOR ACTUATORS

HVAC SYSTEM (AUTO A/C) (DIAGNOSTICS)

Step	Check	Yes	No
1 CHECK POWER SUPPLY FOR AUTO A/C CONTROL MODULE SIDE. 1) Turn ignition switch ON. 2) Turn A/C switch ON. 3) Measure voltage between auto A/C control module harness connector terminal and chassis ground. <i>Connector & terminal</i> <i>(B283) No. 6 (+) — Chassis ground (-):</i>	Is the voltage more than 10V?	Go to step 2.	Replace auto A/C control module.
2 CHECK POWER SUPPLY FOR ACTUATOR SIDE. Measure voltage between mode door actuator harness connector terminal and chassis ground. <i>Connector & terminal</i> <i>(B77) No. 1 (+) — Chassis ground (-):</i>	Is the voltage more than 10V?	Go to step 3.	Repair open circuit in harness between auto A/C control module and mode door actuator.
3 CHECK SIGNAL FOR AUTO A/C CONTROL MODULE SIDE. Measure voltage between auto A/C control module harness connector terminal and chassis ground with oscilloscope. <i>Connector & terminal</i> <i>(B282) No. 12 (+) — Chassis ground (-):</i>	Is the voltage approx. 5.5V?	Go to step 4.	Replace auto A/C control module.
4 CHECK SIGNAL FOR ACTUATOR SIDE. Measure voltage between mode door actuator harness connector terminal and chassis ground. <i>Connector & terminal</i> <i>(B77) No. 3 (+) — Chassis ground (-):</i>	Is the voltage approx. 5.5V?	Go to step 5.	Repair open circuit in harness between auto A/C control module and mode door actuator.
5 CHECK GROUND CIRCUIT OF ACTUATOR. 1) Turn ignition switch and A/C switch OFF. 2) Measure resistance between mode door actuator harness connector terminal and chassis ground. <i>Connector & terminal</i> <i>(B77) No. 2 (+) — Chassis ground (-):</i>	Is the resistance less than 1 Ω ?	Go to step 6.	Repair open circuit in harness between mode door actuator and chassis ground.
6 CHECK POOR CONTACT. Check poor contact in auto A/C control module and mode door actuator.	Is there poor contact?	Repair poor contact.	Contact with your Subaru distributor.

DIAGNOSTIC PROCEDURE FOR ACTUATORS

HVAC SYSTEM (AUTO A/C) (DIAGNOSTICS)

C: AIR MIX DOOR ACTUATOR

TROUBLE SYMPTOM:

Outlet air temperature is not changed.

WIRING DIAGRAM:

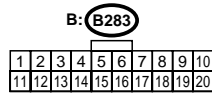
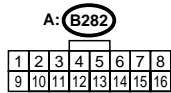
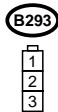
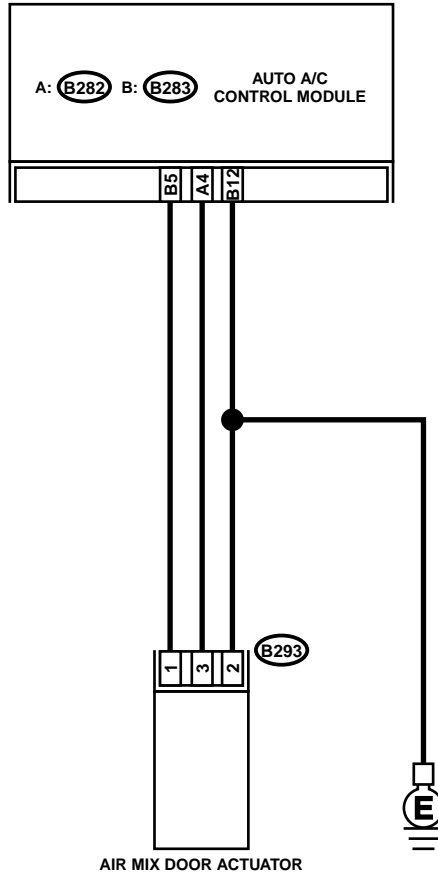

HV0040

DIAGNOSTIC PROCEDURE FOR ACTUATORS

HVAC SYSTEM (AUTO A/C) (DIAGNOSTICS)

Step	Check	Yes	No
1 CHECK POWER SUPPLY FOR AUTO A/C CONTROL MODULE SIDE. 1) Turn ignition switch ON. 2) Turn A/C switch ON. 3) Measure voltage between auto A/C control module harness connector terminal and chassis ground. <i>Connector & terminal</i> <i>(B283) No. 5 (+) — Chassis ground (-):</i>	Is the voltage more than 10V?	Go to step 2.	Replace auto A/C control module.
2 CHECK POWER SUPPLY FOR ACTUATOR SIDE. Measure voltage between air mix door actuator harness connector terminal and chassis ground. <i>Connector & terminal</i> <i>(B293) No. 1 (+) — Chassis ground (-):</i>	Is the voltage more than 10V?	Go to step 3.	Repair open circuit in harness between auto A/C control module and air mix door actuator.
3 CHECK SIGNAL FOR AUTO A/C CONTROL MODULE SIDE. Measure voltage between auto A/C control module harness connector terminal and chassis ground with oscilloscope. <i>Connector & terminal</i> <i>(B282) No. 4 (+) — Chassis ground (-):</i>	Is the voltage approx. 5.5V?	Go to step 4.	Replace auto A/C control module.
4 CHECK SIGNAL FOR ACTUATOR SIDE. Measure voltage between air mix door actuator harness connector terminal and chassis ground with oscilloscope. <i>Connector & terminal</i> <i>(B293) No. 3 (+) — Chassis ground (-):</i>	Is the voltage approx. 5.5V?	Go to step 5.	Repair open circuit in harness between auto A/C control module and air mix door actuator.
5 CHECK GROUND CIRCUIT OF ACTUATOR. 1) Turn ignition switch and A/C switch OFF. 2) Measure resistance between air mix door actuator harness connector terminal and chassis ground. <i>Connector & terminal</i> <i>(B293) No. 2 (+) — Chassis ground (-):</i>	Is the resistance less than 1 Ω ?	Go to step 6.	Repair open circuit in harness between air mix door actuator and chassis ground.
6 CHECK POOR CONTACT. Check poor contact in auto A/C control module and air mix door actuator.	Is there poor contact?	Repair poor contact.	Contact with your Subaru distributor.

DIAGNOSTIC PROCEDURE FOR SENSORS

HVAC SYSTEM (AUTO A/C) (DIAGNOSTICS)

8. Diagnostic Procedure for Sensors

A: AMBIENT SENSOR

TROUBLE SYMPTOM:

Fan speed is not switched when the fan speed control dial is in AUTO position.

WIRING DIAGRAM:

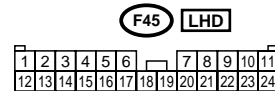
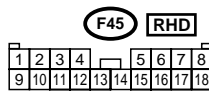
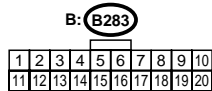
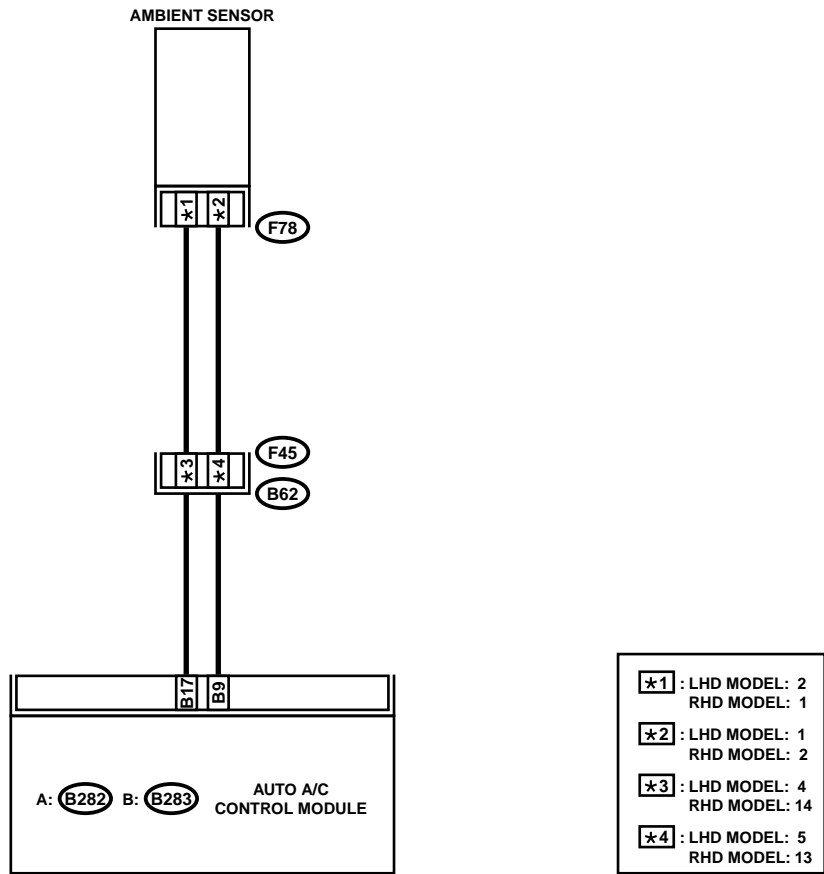

DIAGNOSTIC PROCEDURE FOR SENSORS

HVAC SYSTEM (AUTO A/C) (DIAGNOSTICS)

Step	Check	Yes	No
1 CHECK AMBIENT SENSOR. 1) Turn ignition switch to OFF. 2) Disconnect connector from ambient sensor. 3) Measure resistance between connector terminals of ambient sensor. <i>Terminals:</i> No. 1 — No. 2	Is the resistance approx. 2.2 k Ω at 25°C (77°F)?	Go to step 2.	Replace ambient sensor.
2 CHECK INPUT SIGNALS FOR AMBIENT SENSOR. 1) Turn ignition ON. 2) Measure voltage between (F78) connector terminals. <i>Connector & terminal:</i> (F78) No. 1 — No. 2	Is the voltage approx. 4.5 V?	Go to step 6.	Go to step 3.
3 CHECK OUTPUT SIGNALS FROM A/C CONTROL MODULE. 1) Turn ignition switch to OFF. 2) Pull out A/C control panel. 3) Disconnect connector from ambient sensor. 4) Turn ignition switch to ON. 5) Measure voltage between connector terminals of A/C control module. <i>Connector & terminal:</i> (B283) No. 9 (+) — No. 17 (-)	Is the voltage approx. 4.5 V?	Go to step 6.	Go to step 4.
4 CHECK HARNESS CONNECTOR BETWEEN A/C CONTROL MODULE AND AMBIENT SENSOR. 1) Turn ignition switch to OFF. 2) Disconnect connectors from A/C control module. 3) Measure resistance of harness between A/C control module and ambient sensor. <i>Connector & terminal</i> LHD model: (F78) No. 1 — (B283) No. 9 RHD model: (F78) No. 2 — (B283) No. 9	Is the resistance less than 1 Ω ?	Go to step 5.	Repair open circuit in harness between A/C control module and ambient sensor.
5 CHECK HARNESS CONNECTOR BETWEEN A/C CONTROL MODULE AND AMBIENT SENSOR. Measure resistance of harness between A/C control module and ambient sensor. <i>Connector & terminal</i> LHD model: (F78) No. 2 — (B283) No. 17 RHD model: (F78) No. 1 — (B283) No. 17	Is the resistance less than 1 Ω ?	Go to step 6.	Repair open circuit in harness between A/C control module and ambient sensor.
6 CHECK POOR CONTACT. Check poor contact in A/C control module.	Is there poor contact in A/C control module?	Repair poor contact in A/C control module.	Contact with your Subaru distributor.

DIAGNOSTIC PROCEDURE FOR SENSORS

HVAC SYSTEM (AUTO A/C) (DIAGNOSTICS)

B: IN-VEHICLE SENSOR

TROUBLE SYMPTOM:

When turning AUTO switch to ON, blower fan speed, outlet port and inlet port is not changed.

If switch LED indicates that the sensor is malfunctioning, replace the A/C control module. The in-vehicle sensor is built into the A/C control module and cannot be replaced as a single unit.

DIAGNOSTIC PROCEDURE FOR SENSORS

HVAC SYSTEM (AUTO A/C) (DIAGNOSTICS)

DIAGNOSTIC PROCEDURE FOR SENSORS

HVAC SYSTEM (AUTO A/C) (DIAGNOSTICS)

C: EVAPORATOR SENSOR

WIRING DIAGRAM:

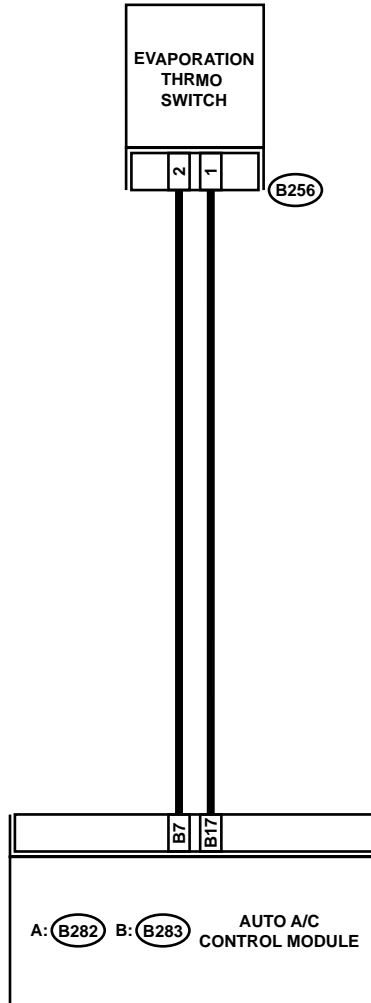

B256

B: B283

1 2

1	2	3	4	5	6	7	8	9	10
11	12	13	14	15	16	17	18	19	20

HV0042

DIAGNOSTIC PROCEDURE FOR SENSORS

HVAC SYSTEM (AUTO A/C) (DIAGNOSTICS)

Step	Check	Yes	No
1 CHECK EVAPORATOR SENSOR. 1) Turn ignition switch to OFF. 2) Remove glove box. 3) Disconnect connector from evaporator sensor. 4) Measure resistance between connector terminals of evaporator sensor. <i>Terminals:</i> No. 1 — No. 2	Is the resistance approx. 3.3 k Ω at 20°C (68°F)?	Go to step 2.	Replace evaporator sensor.
2 CHECK INPUT SIGNALS FOR EVAPORATOR SENSOR. 1) Turn ignition switch to "ON". 2) Measure voltage between (B88) connector terminal and chassis ground. <i>Connector & terminal</i> (B256) No. 2 (+) — Chassis ground (-):	Is the voltage approx. 4.5 V?	Go to step 3.	Replace evaporator sensor.
3 CHECK OUTPUT SIGNALS FROM A/C CONTROL MODULE. 1) Turn ignition switch to OFF. 2) Pull out A/C control module. 3) Turn ignition switch to "ON". 4) Measure voltage between A/C control module connector terminals. <i>Connector & terminal:</i> (B283) No. 7 (+) — No. 17 (-)	Is the voltage approx. 4.5 V?	Go to step 4.	Go to step 6.
4 CHECK HARNESS CONNECTOR BETWEEN A/C CONTROL MODULE AND EVAPORATOR SENSOR. 1) Turn ignition switch to OFF. 2) Disconnect connectors from A/C control module. 3) Measure resistance of harness between A/C control module and evaporator sensor. <i>Connector & terminal:</i> (B256) No. 2 — (B283) No. 7	Is the resistance less than 1 Ω ?	Go to step 5.	Repair open circuit in harness between A/C control module and evaporator sensor.
5 CHECK HARNESS CONNECTOR BETWEEN A/C CONTROL MODULE AND EVAPORATOR SENSOR. Measure resistance of harness between A/C control module and evaporator sensor. <i>Connector & terminal:</i> (B256) No. 1 — (B283) No. 17	Is the resistance less than 1 Ω ?	Go to step 6.	Repair open circuit in harness between A/C control module and evaporator sensor.
6 CHECK POOR CONTACT. Check poor contact in A/C control module.	Is there poor contact in A/C control module?	Repair poor contact in A/C control module.	Contact with your Subaru distributor.

DIAGNOSTIC PROCEDURE FOR SENSORS

HVAC SYSTEM (AUTO A/C) (DIAGNOSTICS)

DIAGNOSTIC PROCEDURE FOR SENSORS

HVAC SYSTEM (AUTO A/C) (DIAGNOSTICS)

D: SUNLOAD SENSOR

TROUBLE SYMPTOM:

- Sensor identified that sunlight is at maximum. Then, A/C system is controlled to COOL side.
- Sensor identified that sunlight is at minimum. Then, A/C system is controlled to HOT side.

NOTE:

When the sunload sensor is checked indoors or in the shade, open circuit might be indicated. Always check the sunload sensor at a place where sun shines directly on it.

DIAGNOSTIC PROCEDURE FOR SENSORS

HVAC SYSTEM (AUTO A/C) (DIAGNOSTICS)

WIRING DIAGRAM:

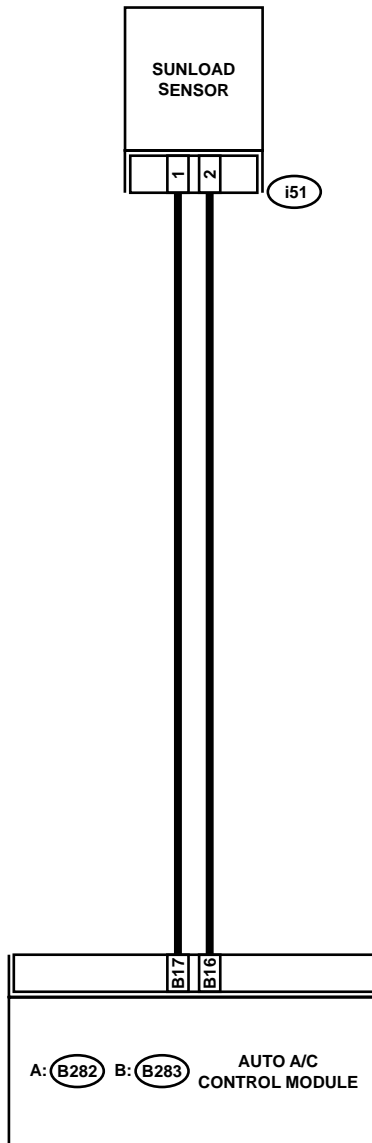

i51

B: B283

1 2

1	2	3	4	5	6	7	8	9	10
11	12	13	14	15	16	17	18	19	20

HV0043

DIAGNOSTIC PROCEDURE FOR SENSORS

HVAC SYSTEM (AUTO A/C) (DIAGNOSTICS)

Step	Check	Yes	No
1 CHECK SUNLOAD SENSOR. 1) Turn ignition switch to OFF. 2) Remove sunload sensor. <Ref. to AC-35, INSTALLATION, Sun-load Sensor (Auto A/C).> 3) Measure resistance between sunload sensor terminals. <i>Terminals:</i> No. 2 — No. 1	Is the resistance less than 1 Ω ?	Go to step 2.	Replace sunload sensor.
2 CHECK SUNLOAD SENSOR. Make sure that there is no resistance in the reverse side terminals. <i>Terminals:</i> No. 1 — No. 2	Is the resistance more than 1 M Ω ?	Go to step 3.	Replace sunload sensor.
3 CHECK INPUT VOLTAGE TO SUNLOAD SENSOR. 1) Turn ignition switch to ON. 2) Measure input voltage to sunload sensor. <i>Connector & terminal:</i> (i51) No. 2 (+) — No. 1 (-)	Is the voltage approx. 4.5 V?	Go to step 6.	Go to step 4.
4 CHECK HARNESS CONNECTOR BETWEEN A/C CONTROL MODULE AND SUNLOAD SENSOR. 1) Turn ignition switch to OFF. 2) Disconnect connectors from A/C control module. 3) Measure resistance of harness between A/C control module and sunload sensor. <i>Connector & terminal:</i> (i51) No. 2 — (B283) No. 16	Is the resistance less than 1 Ω ?	Go to step 5.	Repair open circuit in harness between A/C control module and sunload sensor.
5 CHECK HARNESS CONNECTOR BETWEEN A/C CONTROL MODULE AND SUNLOAD SENSOR. Measure resistance of harness between A/C control module and sunload sensor. <i>Connector & terminal:</i> (i51) No. 1 — (B283) No. 17	Is the resistance less than 1 Ω ?	Go to step 6.	Repair open circuit in harness between A/C control module and sunload sensor.
6 CHECK POOR CONTACT. Check poor contact in A/C control module.	Is there poor contact in A/C control module?	Repair poor contact in A/C control module.	Contact with your Subaru distributor.

SYMPTOM RELATED DIAGNOSTIC

HVAC SYSTEM (AUTO A/C) (DIAGNOSTICS)

9. Symptom Related Diagnostic

A: GENERAL DIAGNOSTICS TABLE

Symptom	A/C system fails to operate when IG SW is turned "ON".	Burned-out fuse.	Illumination does not dim at night.	Blower motor does not rotate or rotates erroneously.	A/C does not change from "Fresh" to "Recirc" or vice versa.	Air outlet cannot be switched.	Compartment temperature does not increase (No hot air is discharged).	Compartment temperature does not decrease (No cool air is discharged).	Compartment temperature is higher than or lower than the set value.	Compartment temperature does not quickly respond to the set value.	Condenser fan does not operate during A/C operation.
Component parts											
Fuses (M/B No. 5, F/B No. 17)	<input type="radio"/>	<input type="radio"/>	<input type="radio"/>	<input type="radio"/>							
Poor connector contacts	<input type="radio"/>	<input type="radio"/>	<input type="radio"/>	<input type="radio"/>	<input type="radio"/>	<input type="radio"/>	<input type="radio"/>	<input type="radio"/>			
Ground	<input type="radio"/>			<input type="radio"/>							
A/C control module	<input type="radio"/>		<input type="radio"/>	<input type="radio"/>	<input type="radio"/>	<input type="radio"/>	<input type="radio"/>	<input type="radio"/>	<input type="radio"/>		
Air mix door actuator and potention meter (including links)							<input type="radio"/>	<input type="radio"/>	<input type="radio"/>	<input type="radio"/>	
Mode door actuator and potention meter (including links)						<input type="radio"/>					
Intake door actuator and potention meter (including links)					<input type="radio"/>						
Blower fan motor				<input type="radio"/>							
Blower fan relay				<input type="radio"/>							
A/C relay								<input type="radio"/>			
Magnet clutch								<input type="radio"/>			
Radiator fan motors (Main and sub)											<input type="radio"/>
Radiator fan relays (Main and sub)											<input type="radio"/>
Sensors (In-vehicle, ambient, water temperature, evaporator, sunload, etc.)							<input type="radio"/>	<input type="radio"/>	<input type="radio"/>	<input type="radio"/>	
In-vehicle sensor aspirator duct								<input type="radio"/>			

HV0044