

CHASSIS SECTION

This service manual has been prepared to provide SUBARU service personnel with the necessary information and data for the correct maintenance and repair of SUBARU vehicles.

This manual includes the procedures for maintenance, disassembling, reassembling, inspection and adjustment of components and diagnostics for guidance of experienced mechanics.

Please peruse and utilize this manual fully to ensure complete repair work for satisfying our customers by keeping their vehicle in optimum condition. When replacement of parts during repair work is needed, be sure to use SUBARU genuine parts.

All information, illustration and specifications contained in this manual are based on the latest product information available at the time of publication approval.

FRONT SUSPENSION**FS****REAR SUSPENSION****RS****WHEEL AND TIRE SYSTEM****WT****DIFFERENTIALS****DI****TRANSFER CASE****TC****DRIVE SHAFT SYSTEM****DS****ABS****ABS****ABS (DIAGNOSTICS)****ABS****BRAKE****BR****PARKING BRAKE****PB****POWER ASSISTED SYSTEM
(POWER STEERING)****PS**

FRONT SUSPENSION



| | Page |
|----------------------------------|-------------|
| 1. General Description | 2 |
| 2. Wheel Alignment | 8 |
| 3. Front Transverse Link | 16 |
| 4. Front Ball Joint | 18 |
| 5. Front Strut | 19 |
| 6. Front Stabilizer | 23 |
| 7. Front Crossmember | 24 |
| 8. General Diagnostic Table..... | 25 |

GENERAL DESCRIPTION

FRONT SUSPENSION

1. General Description

A: SPECIFICATIONS

1. STABILIZER

| Model | Bar dia. |
|-----------|-----------------|
| ALL MODEL | 20 mm (0.79 in) |

2. WHEEL ALIGNMENT

| Model | Sedan | | Wagon | | OUTBACK |
|--|--|----------------------|----------------------|----------------------|----------------------|
| | Turbo | Non-turbo | Turbo | Non-turbo | |
| Camber (tolerance: $\pm 0^{\circ}45'$) | $-0^{\circ}25'$ | $-0^{\circ}15'$ | $-0^{\circ}20'$ | $-0^{\circ}10'$ | $-0^{\circ}05'$ |
| Caster (common difference: $\pm 0^{\circ}45'$) | $3^{\circ}35'$ | $3^{\circ}25'$ | $3^{\circ}35'$ | $3^{\circ}25'$ | $3^{\circ}25'$ |
| Toe-in | 0 \pm 3 mm (0 \pm 0.12 in) Each toe angle: $\pm 0^{\circ}07'30''$ | | | | |
| Kingpin angle (tolerance: $\pm 0^{\circ}45'$) | $14^{\circ}35'$ | $14^{\circ}20'$ | $13^{\circ}45'$ | $13^{\circ}30'$ | $13^{\circ}20'$ |
| Wheel arch height [tolerance: ± 12 mm (± 0.47 in)] | 396 mm (15.59 in) | 406 mm (15.98 in) | 387 mm (15.24 in) | 397 mm (15.63 in) | 402 mm (15.83 in) |

NOTE:

- Front and rear toe-ins and front camber can be adjusted. If toe-in or camber tolerance exceeds specifications, adjust toe-in and camber to the middle value of specification.
- The other items indicated in the specification table cannot be adjusted. If the other items exceeds specifications, check suspension parts and connections for deformities; replace with new ones as required.

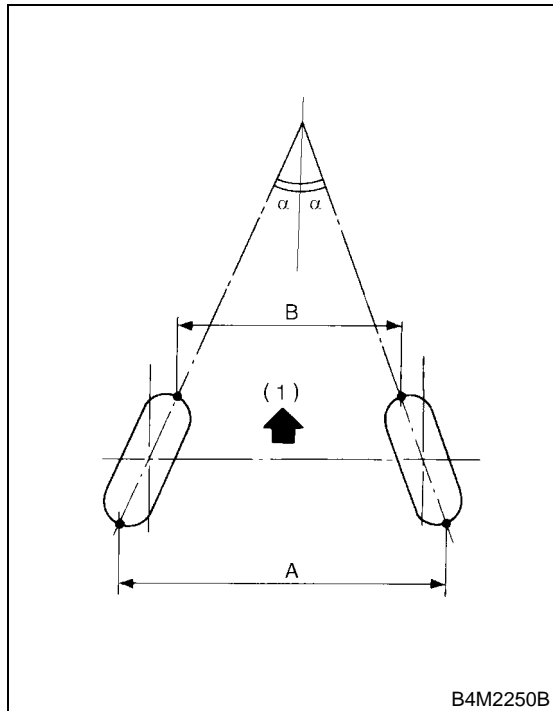

(1) Front

A – B = Positive: Toe-in, Negative: Toe-out

α = Each toe angle

GENERAL DESCRIPTION

FRONT SUSPENSION

B: COMPONENT

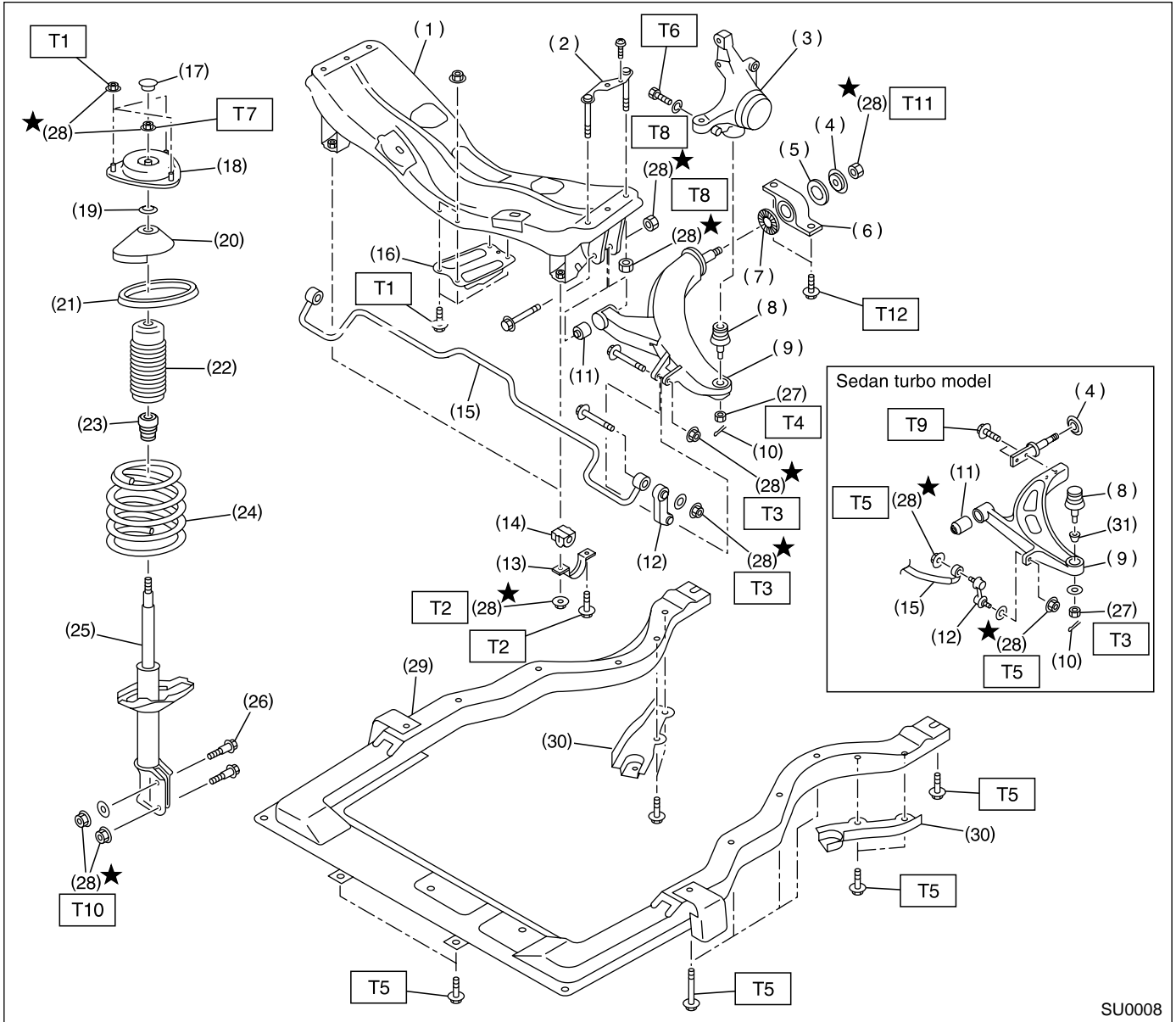

SU0008

GENERAL DESCRIPTION

FRONT SUSPENSION

| | | |
|----------------------------|------------------------|---|
| (1) Front crossmember | (16) Jack-up plate | (31) Boss |
| (2) Bolt ASSY | (17) Dust seal | |
| (3) Housing | (18) Strut mount | <i>Tightening torque: N·m (kgf-m, ft-lb)</i> |
| (4) Washer | (19) Spacer | <i>T1: 20 (2.0, 14.5)</i> |
| (5) Stopper rubber (Rear) | (20) Upper spring seat | <i>T2: 25 (2.5, 18.1)</i> |
| (6) Rear bushing | (21) Rubber seat | <i>T3: 30 (3.1, 22)</i> |
| (7) Stopper rubber (Front) | (22) Dust cover | <i>T4: 40 (4.1, 30)</i> |
| (8) Ball joint | (23) Helper | <i>T5: 45 (4.6, 33)</i> |
| (9) Transverse link | (24) Coil spring | <i>T6: 50 (5.1, 37)</i> |
| (10) Cotter pin | (25) Damper strut | <i>T7: 55 (5.6, 41)</i> |
| (11) Front bushing | (26) Adjusting bolt | <i>T8: 100 (10.2, 74)</i> |
| (12) Stabilizer link | (27) Castle nut | <i>T9: 155 (15.8, 114)</i> |
| (13) Clamp | (28) Self-locking nut | <i>T10: 175 (17.8, 129)</i> |
| (14) Bushing | (29) Sub frame | <i>T11: 190 (19.4, 140)</i> |
| (15) Stabilizer | (30) Cover | <i>T12: 250 (25.5, 184)</i> |

GENERAL DESCRIPTION

FRONT SUSPENSION

C: CAUTION

- Wear working clothing, including a cap, protective goggles, and protective shoes during operation.
- Remove contamination including dirt and corrosion before removal, installation or disassembly.
- Keep the disassembled parts in order and protect them from dust or dirt.
- Before removal, installation or disassembly, be sure to clarify the failure. Avoid unnecessary removal, installation, disassembly, and replacement.
- Use SUBARU genuine grease etc. or the equivalent. Do not mix grease etc. with that of another grade or from other manufacturers.
- Be sure to tighten fasteners including bolts and nuts to the specified torque.
- Place shop jacks or safety stands at the specified points.
- Apply grease onto sliding or revolution surfaces before installation.
- Before installing O-rings or snap rings, apply sufficient amount of grease to avoid damage and deformation.
- Before securing a part on a vice, place cushioning material such as wood blocks, aluminum plate, or shop cloth between the part and the vice.

GENERAL DESCRIPTION

FRONT SUSPENSION

D: PREPARATION TOOL

1. SPECIAL TOOLS

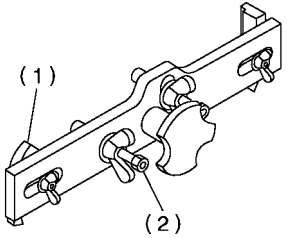
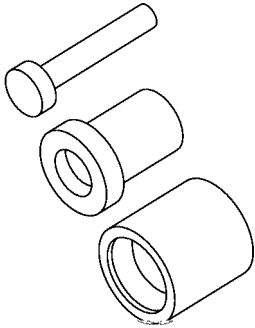
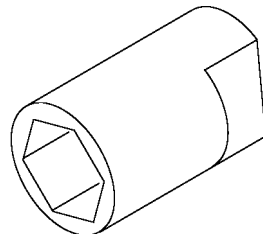
| ILLUSTRATION | TOOL NUMBER | DESCRIPTION | REMARKS |
|---|-------------|----------------------------|---|
|  <p style="text-align: right;">B4M2378A</p> | 927380002 | ADAPTER | Used as an adapter for camber & caster gauge when measuring camber and caster. (1) 28199AC000 PLATE (2) 28199AC010 BOLT |
|  <p style="text-align: right;">B4M2385</p> | 927680000 | INSTALLER & REMOVER SET | Used for replacing transverse link bushing. |
|  <p style="text-align: right;">B4M2384</p> | 927760000 | STRUT MOUNT SOCKET | Used for disassembling and assembling strut and shock mount. |

2. GENERAL PURPOSE TOOLS

| TOOL NAME | REMARKS |
|----------------------|---------------------------------------|
| Alignment gauge | Used for wheel alignment measurement. |
| Turning radius gauge | Used for wheel alignment measurement. |
| Toe-in gauge | Used for toe-in measurement. |
| Dial gauge | Used for damper strut measurement. |

WHEEL ALIGNMENT

FRONT SUSPENSION

2. Wheel Alignment

A: INSPECTION

Check, adjust and/or measure wheel alignment in accordance with procedures indicated in figure:

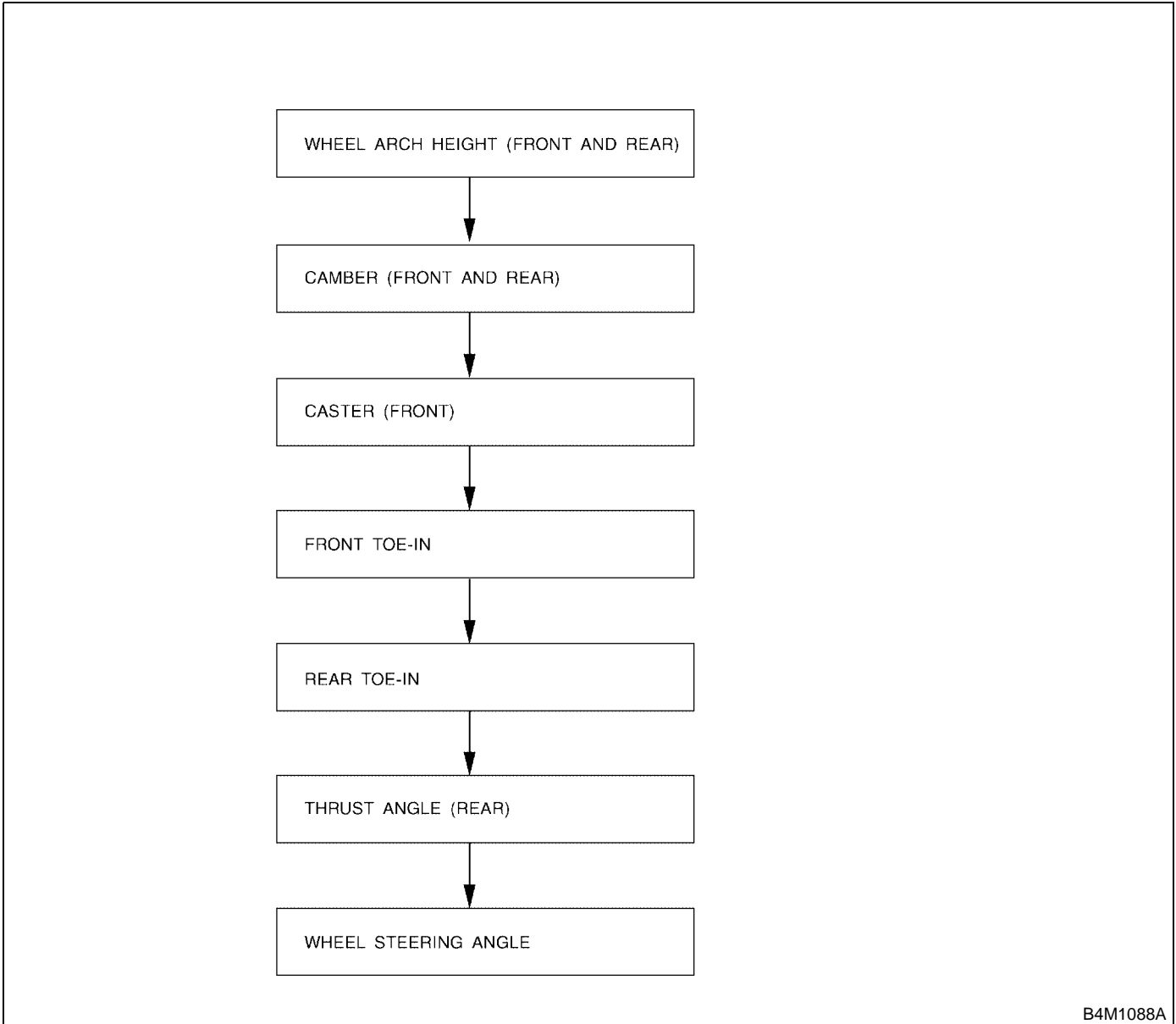

B4M1088A

WHEEL ALIGNMENT

FRONT SUSPENSION

1. WHEEL ARCH HEIGHT

- 1) Adjust tire pressure to specifications.
- 2) Set vehicle under "curb weight" conditions. (Empty luggage compartment, install spare tire, jack, service tools, and top up fuel tank.)
- 3) Set steering wheel in a wheel-forward position.
- 4) Suspend thread from wheel arch (point "A" in figure below) to determine a point directly above center of spindle.
- 5) Measure distance between measuring point "A" and center of spindle.

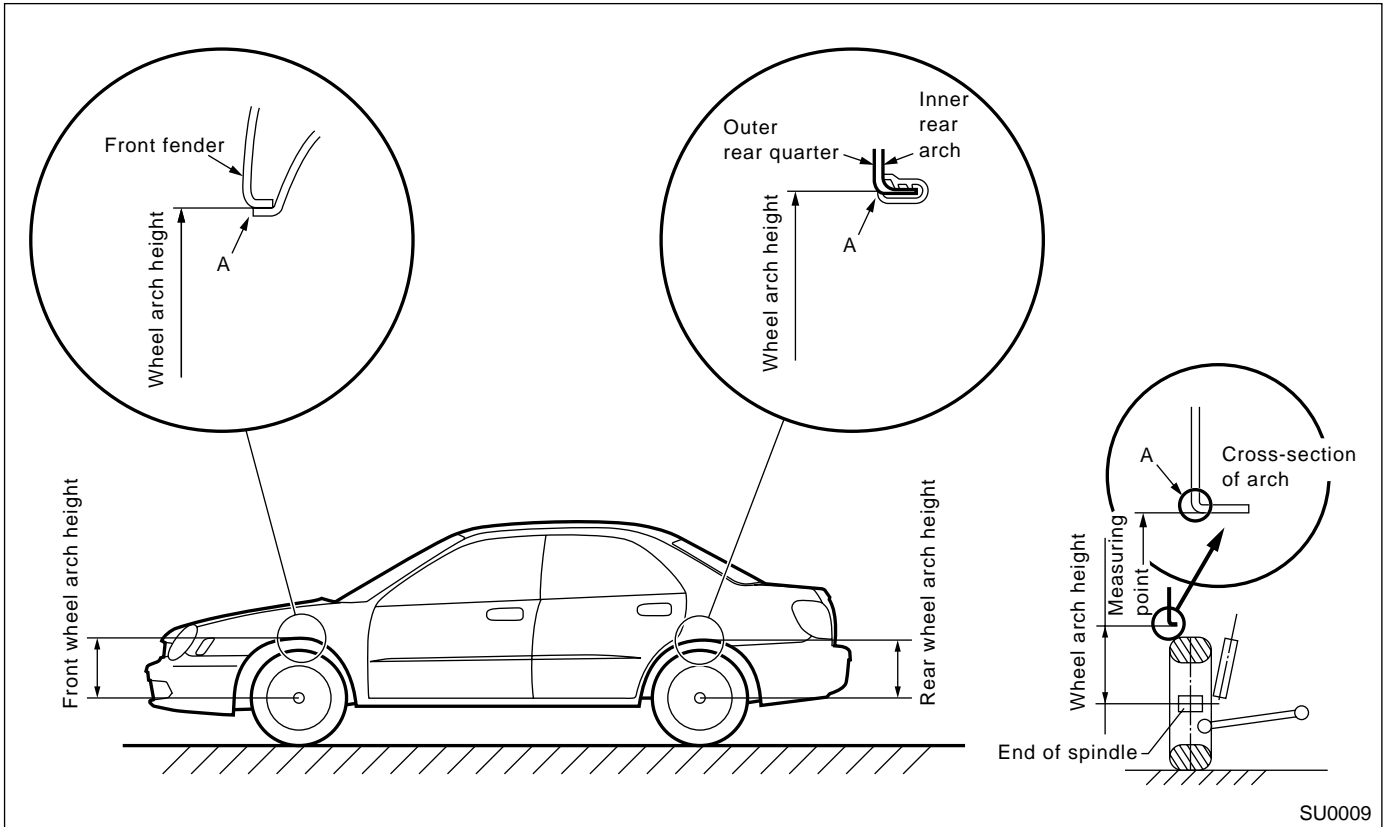

| Model | | Specified wheel arch height | |
|---------|-------|-----------------------------|---------------------------|
| | | Turbo | Non-turbo |
| Sedan | Front | 396±12 mm (15.59±0.47 in) | 406±12 mm (15.98±0.47 in) |
| | Rear | 376±12 mm (14.80±0.47 in) | 381±12 mm (15.0±0.47 in) |
| Wagon | Front | 387±12 mm (15.24±0.47 in) | 397±12 mm (15.63±0.47 in) |
| | Rear | 376±12 mm (14.80±0.47 in) | 381±12 mm (15.0±0.47 in) |
| OUTBACK | Front | — | 402±12 mm (15.83±0.47 in) |
| | Rear | — | 386±12 mm (15.20±0.47 in) |

WHEEL ALIGNMENT

FRONT SUSPENSION

2. CAMBER

• Inspection

1) Place front wheel on turning radius gauge. Make sure ground contacting surfaces of front and rear wheels are set at the same height.

2) Set ST into the center of the wheel, and then install the wheel alignment gauge.

ST 927380002 ADAPTER

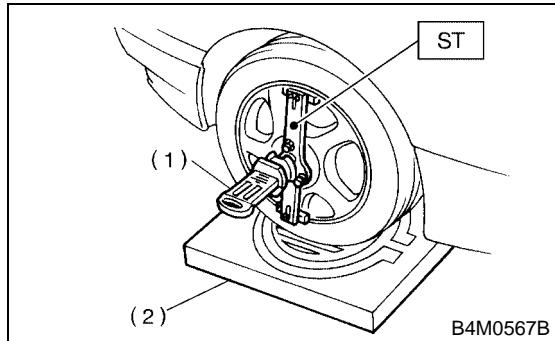

- (1) Alignment gauge
- (2) Turning radius gauge

NOTE:

Refer to the "SPECIFICATIONS" for the camber values.

Front: <Ref. to FS-2, SPECIFICATIONS, General Description.>

Rear: <Ref. to RS-2, SPECIFICATIONS, General Description.>

• Front camber adjustment

1) Loosen two self-locking nuts located at lower front portion of strut.

CAUTION:

• When adjusting bolt needs to be loosened or tightened, hold its head with a wrench and turn self-locking nut.

• Discard loosened self-locking nut and replace with a new one.

2) Turn camber adjusting bolt so that camber is set at the specification.

NOTE:

Moving the adjusting bolt by one scale graduation changes camber by approximately $0^{\circ}10'$.

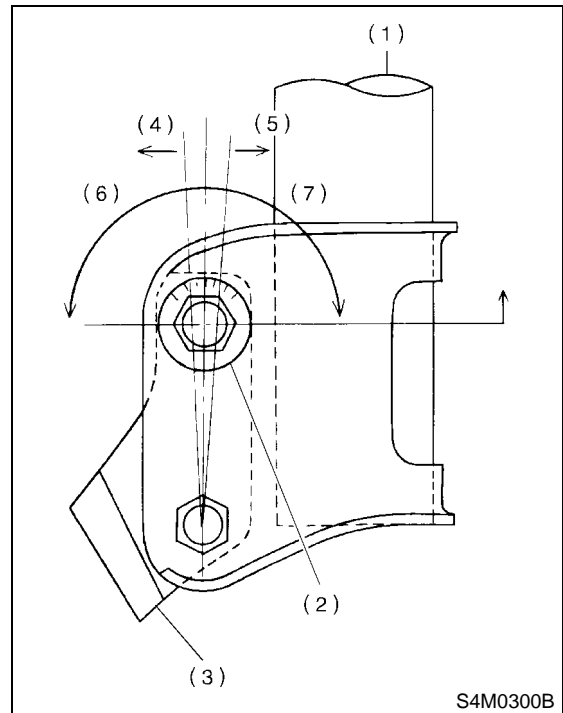

- (1) Strut
- (2) Adjusting bolt
- (3) Housing
- (4) Outer
- (5) Inner
- (6) Camber is increased.
- (7) Camber is decreased.

WHEEL ALIGNMENT

FRONT SUSPENSION

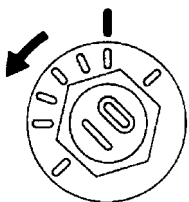
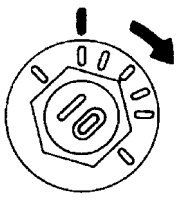
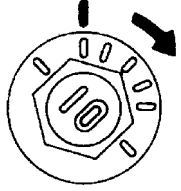
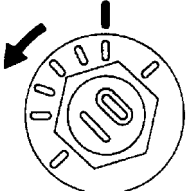
| | Left side | Right side |
|----------------------|--|---|
| Camber is increased. |  <p>B4M0190</p> <p>Rotate counterclockwise.</p> |  <p>B4M0350</p> <p>Rotate clockwise.</p> |
| Camber is decreased. |  <p>B4M0350</p> <p>Rotate clockwise.</p> |  <p>B4M0190</p> <p>Rotate counterclockwise.</p> |

3) Tighten the two self-locking nuts.

Tightening torque:

175 N·m (17.8 kgf·m, 129 ft·lb)

3. CASTER

• Inspection

- 1) Place front wheel on turning radius gauge. Make sure ground contacting surfaces of front and rear wheels are set at the same height.
 - 2) Set ST into the center of the wheel, and then install the wheel alignment gauge.
- ST 927380002 ADAPTER

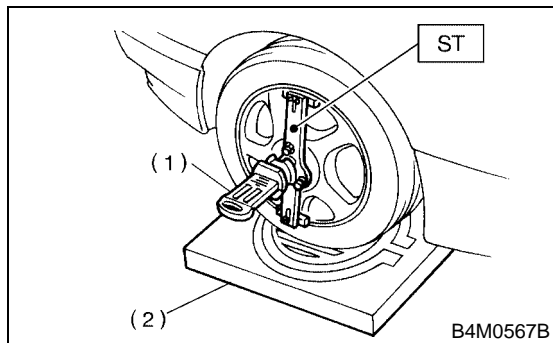

- (1) Alignment gauge
- (2) Turning radius gauge

NOTE:

Refer to the "SPECIFICATIONS" for the caster values. <Ref. to FS-2, SPECIFICATIONS, General Description.>

4. FRONT WHEEL TOE-IN

• Inspection

- 1) Using a toe gauge, measure front wheel toe-in.

Toe-in:

0±3 mm (0±0.12 in)

- 2) Mark rear sides of left and right tires at height corresponding to center of spindles and measure distance "A" between marks.
- 3) Move vehicle forward so that marks line up with front sides at height corresponding to center of spindles.
- 4) Measure distance "B" between left and right marks. Toe-in can then be obtained by the following equation:

$$A - B = \text{Toe-in}$$

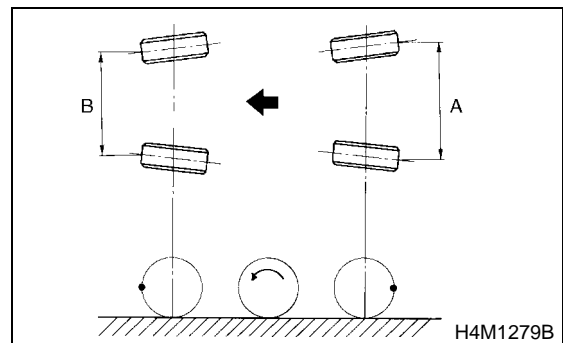

• Adjustment

- 1) Loosen the left and right side steering tie-rod lock nuts.

WHEEL ALIGNMENT

FRONT SUSPENSION

2) Turn the left and right tie rods equal amounts until the toe-in is at the specification.

Both the left and right tie-rods are right-hand threaded. To increase toe-in, turn both tie-rods clockwise equal amounts (as viewed from the inside of the vehicle).

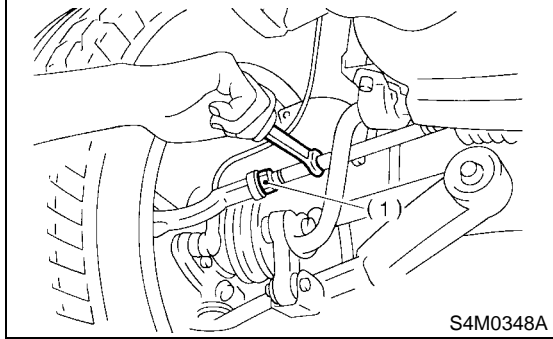

(1) Lock nut

3) Tighten tie-rod lock nut.

Tightening torque:

83 N-m (8.5 kgf-m, 61.5 ft-lb)

CAUTION:

Correct tie-rod boot, if it is twisted.

NOTE:

Check the left and right wheel steering angle is within specifications.

5. REAR WHEEL TOE-IN

• Inspection

1) Using a toe-in gauge, measure rear wheel toe-in.

Toe-in:

-1±2 mm (-0.039±0.079 in)

2) Mark rear sides of left and right tires at height corresponding to center of spindles and measure distance "A" between marks.

3) Move vehicle forward so that marks line up with front sides at height corresponding to center of spindles.

4) Measure distance "B" between left and right marks. Toe-in can then be obtained by the following equation:

$$A - B = \text{Toe-in}$$

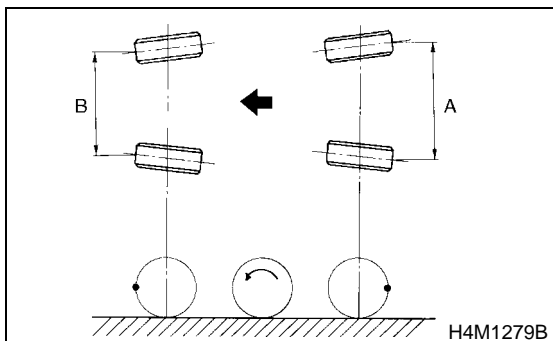

• Adjustment

1) Loosen self-locking nut on inner side of link rear.

CAUTION:

• **When loosening or tightening adjusting bolt, hold bolt head and turn self-locking nut.**

• **Discard loosened self-locking nut and replace with a new one.**

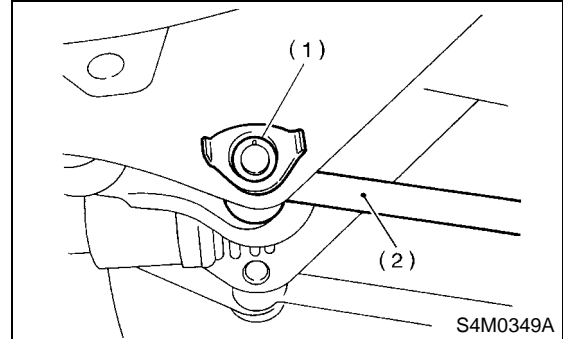

(1) Adjusting bolt

(2) Link rear

2) Turn adjusting bolt head until toe-in is at the specification.

WHEEL ALIGNMENT

FRONT SUSPENSION

NOTE:

When left and right wheels are adjusted for toe-in at the same time, the movement of one scale graduation changes toe-in by approximately 1.5 mm (0.12 in).

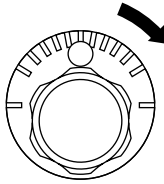
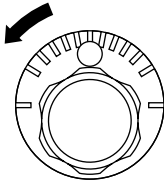
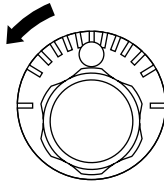
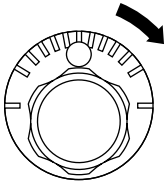
| | Left side | Right side |
|----------------------|--|--|
| Toe-in is increased. |  <p>Rotate clockwise.</p> <p>B4M0192</p> |  <p>Rotate counterclockwise.</p> <p>B4M0352</p> |
| Toe-in is decreased. |  <p>Rotate counterclockwise.</p> <p>B4M0352</p> |  <p>Rotate clockwise.</p> <p>B4M0192</p> |

3) Tighten self-locking nut.

Tightening torque:

100 N·m (10.2 kgf-m, 74 ft-lb)

6. STEERING ANGLE

• Inspection

- 1) Place vehicle on a turning radius gauge.
- 2) While depressing brake pedal, turn steering wheel fully to the left and right. With steering wheel held at each fully turned position, measure both the inner and outer wheel steering angle.

Steering angle:

| Model | Turbo and OUT-BACK | Others |
|-------------|---------------------------------|---------------------------------|
| Inner wheel | $34^{\circ}30' \pm 1.5^{\circ}$ | $37^{\circ}20' \pm 1.5^{\circ}$ |
| Outer wheel | $34^{\circ}30' \pm 1.5^{\circ}$ | $32^{\circ}25' \pm 1.5^{\circ}$ |

• Adjustment

Turn tie-rod to adjust steering angle of both inner and outer wheels.

CAUTION:

- Check toe-in.
- Correct boot if it is twisted.

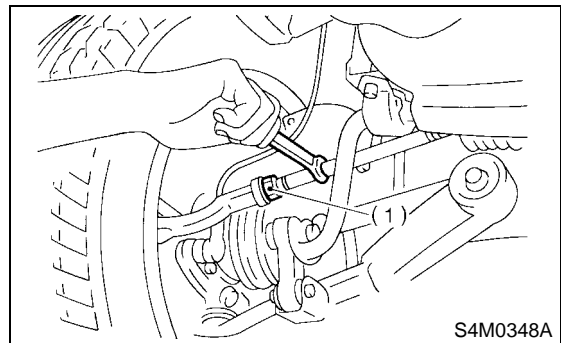

(1) Lock nut

S4M0348A

WHEEL ALIGNMENT

FRONT SUSPENSION

7. THRUST ANGLE

• Inspection

- 1) Position vehicle on a level surface.
- 2) Move vehicle 3 to 4 meters directly forward.
- 3) Determine locus of both front and rear axles.
- 4) Measure distance "L" between center line of loci of the axles.

Thrust angle:

Less than 20' when "L" is equal to or less than 15 mm (59 in).

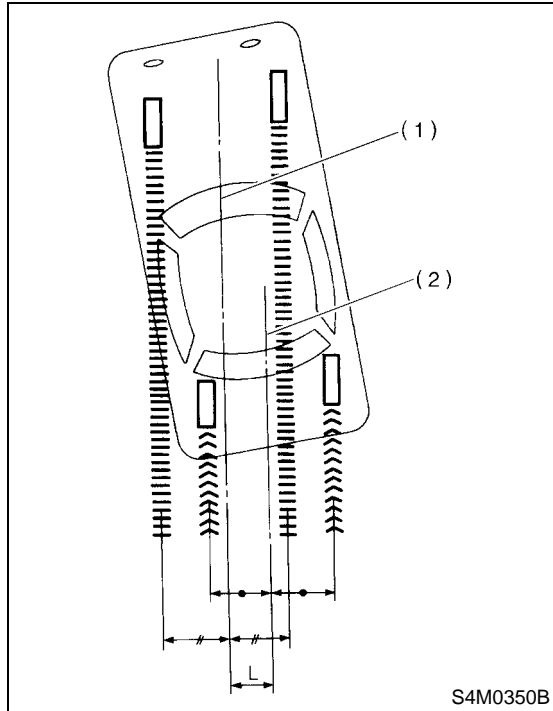

- (1) Center line of loci (front axle)
- (2) Center line of loci (rear axle)

• Adjustment

- 1) Make thrust angle adjustments by turning toe-in adjusting bolts of rear suspension equally in the same direction.
- 2) When one rear wheel is adjusted in a toe-in direction, adjust the other rear wheel equally in toe-out direction, in order to make thrust angle adjustment.

- 3) When left and right adjusting bolts are turned incrementally by one graduation in the same direction, the thrust angle will change approximately 16' ["L" is almost equal to 12 mm (0.472 in)].

Thrust angle:

0°±20'

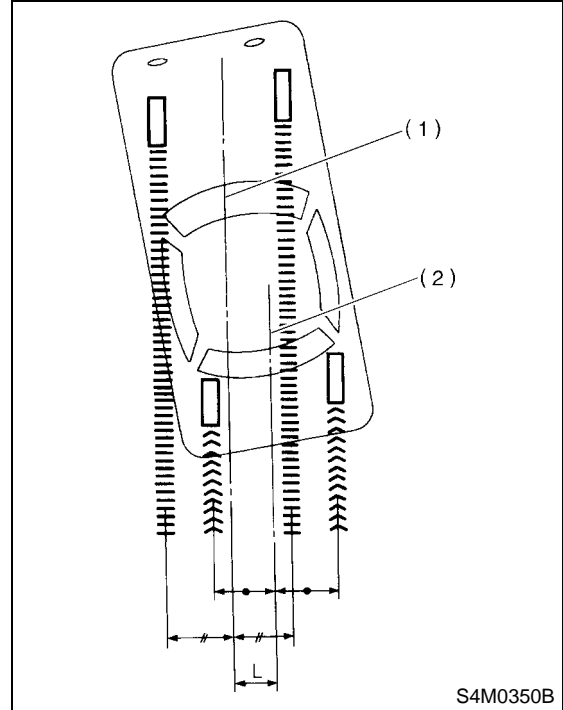

- (1) Center line of loci (front axle)
- (2) Center line of loci (rear axle)

NOTE:

Thrust angle refers to a mean value of left and right rear wheel toe angles in relation to vehicle body center line. Vehicle is driven straight in the thrust angle direction while swinging in the oblique direction depending on the degree of the mean thrust angle.

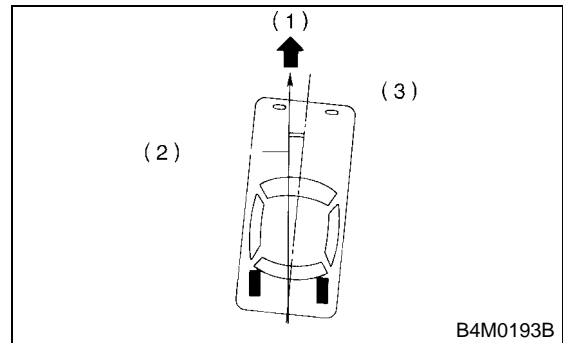

- (1) Front
- (2) Thrust angle
- (3) Body center line

Thrust angle: $r = (\alpha - \beta)/2$

α : Right rear wheel toe-in angle

β : Left rear wheel toe-in angle

NOTE:

Here, use only positive toe-in values from each wheel to substitute for α and β in the equation.

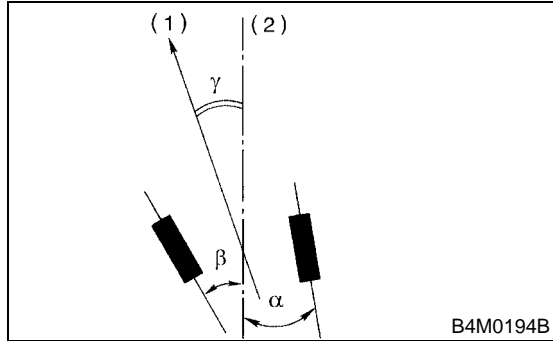

(1) Front

(2) Body center line

FRONT TRANSVERSE LINK

FRONT SUSPENSION

3. Front Transverse Link

A: REMOVAL

- 1) Set the vehicle on the lift.
- 2) Disconnect ground terminal from battery.
- 3) Lift-up the vehicle and remove the wheel.
- 4) Remove sub frame.
- 5) Disconnect stabilizer link from transverse link.
- 6) Remove bolt securing ball joint of transverse link to housing.

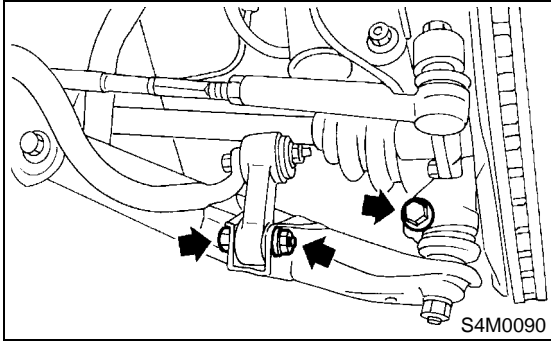

- 7) Remove nut (do not remove bolt.) securing transverse link to crossmember.
- 8) Remove two bolts securing bushing bracket of transverse link to vehicle body at rear bushing location.

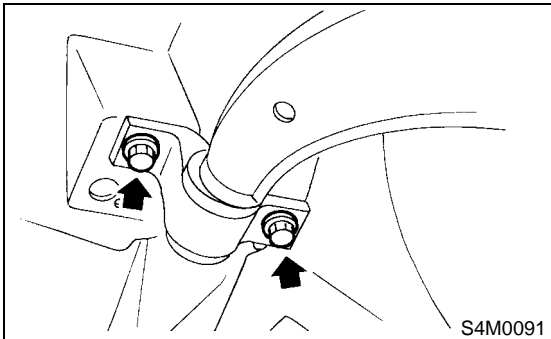

- 9) Extract ball joint from housing.
- 10) Remove bolt securing transverse link to crossmember and extract transverse link from crossmember.

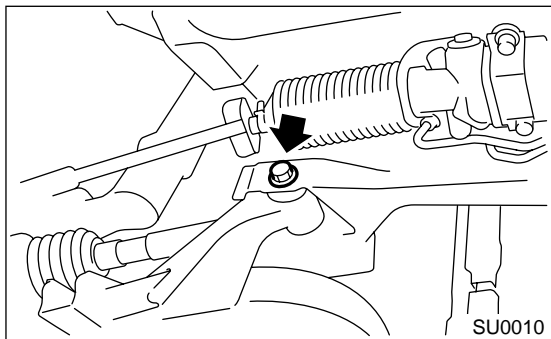

B: INSTALLATION

- 1) Temporarily tighten the two bolts used to secure rear bushing of the transverse link to body.

NOTE:

These bolts should be tightened to such an extent that they can still move back and forth in the oblong shaped hole in the bracket (which holds the bushing).

- 2) Install bolts used to connect transverse link to crossmember and temporarily tighten with nut.

CAUTION:

Discard loosened self-locking nut and replace with a new one.

- 3) Insert ball joint into housing.
- 4) Connect stabilizer link to transverse link, and temporarily tighten bolts.

CAUTION:

Discard loosened self-locking nut and replace with a new one.

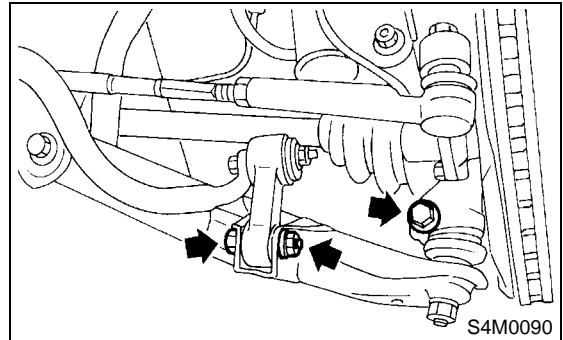

- 5) Tighten the following points in the order shown below when wheels are in full contact with the ground and vehicle is curb weight.

- (1) Transverse link and stabilizer

Tightening torque:

Sedan Turbo model:

45 N·m (4.6 kgf-m, 33 ft-lb)

Except sedan Turbo model:

30 N·m (3.1 kgf-m, 22 ft-lb)

- (2) Transverse link and crossmember

Tightening torque:

100 N·m (10.2 kgf-m, 74 ft-lb)

- (3) Transverse link rear bushing and body

Tightening torque:

250 N·m (25.5 kgf-m, 184 ft-lb)

NOTE:

- Move rear bushing back and forth until transverse link-to-rear bushing clearance is established (as indicated in figure.) before tightening.
- Check wheel alignment and adjust if necessary.

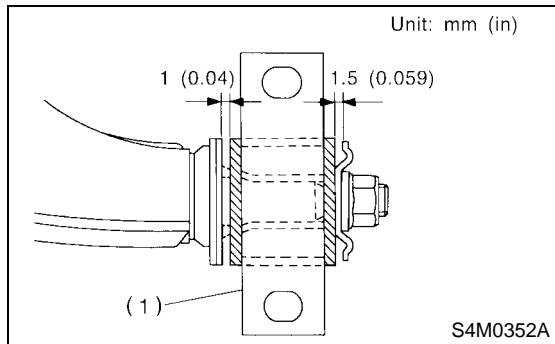

(1) Rear bushing

C: DISASSEMBLY

1. FRONT BUSHING

Using ST, press front bushing out of place.
 ST 927680000 INSTALLER & REMOVER SET

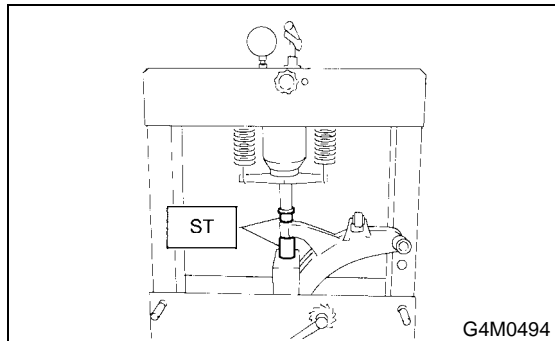

2. REAR BUSHING

- 1) Scribe an aligning mark on transverse link and rear bushing.
- 2) Loosen nut and remove rear bushing.

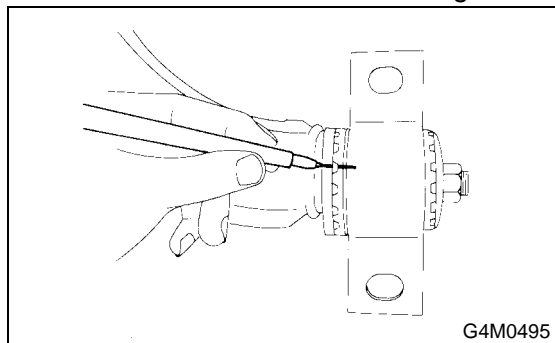

D: ASSEMBLY

1. FRONT BUSHING

To reassemble, reverse disassembly procedures.

CAUTION:

Install front bushing in correct direction, as shown in figure.

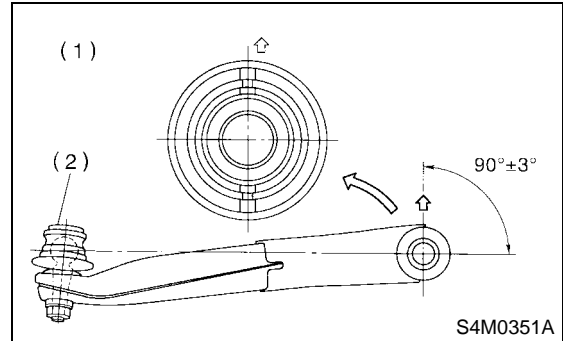

- (1) Face bushing toward center of ball joint
- (2) Ball joint

2. REAR BUSHING

- 1) Install rear bushing to transverse link and align aligning marks scribed on the two.
- 2) Tighten self-locking nut.

CAUTION:

- Discard loosened self-locking nut and replace with a new one.
- While holding rear bushing so as not to change position of aligning marks, tighten self-locking nut.

Tightening torque:

190 N·m (19.4 kgf-m, 140 ft-lb)

E: INSPECTION

- 1) Check transverse link for wear, damage and cracks, and correct or replace if defective.
- 2) Check bushings for cracks, fatigue or damage.
- 3) Check rear bushing for oil leaks.

FRONT BALL JOINT

FRONT SUSPENSION

4. Front Ball Joint

A: REMOVAL

- 1) Remove the wheel.
- 2) Pull out the cotter pin from the ball stud, remove the castle nut, and extract the ball stud from the transverse link.
- 3) Remove the bolt securing the ball joint to the housing.

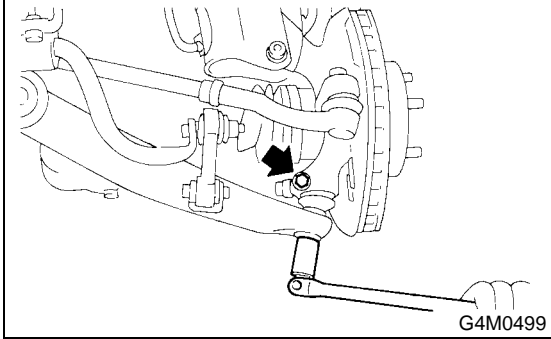

- 4) Extract the ball joint from the housing.

B: INSTALLATION

- 1) Install ball joint onto housing.

Torque (Bolt):

50 N·m (5.1 kgf·m, 37 ft·lb)

CAUTION:

Do not apply grease to tapered portion of ball stud.

- 2) Connect ball joint to transverse link.

Torque (Castle nut):

Sedan turbo model:

30 N·m (3.1 kgf·m, 22ft·lb)

Except sedan turbo model:

40 N·m (4.1 kgf·m, 30ft·lb)

- 3) Retighten castle nut further within 60° until a slot in castle nut is aligned with the hole in ball stud end, then insert new cotter pin and bend it around castle nut.
- 4) Install front wheel.

C: INSPECTION

- 1) Measure play of ball joint by the following procedures. Replace with a new one when the play exceeds the specified value.

- (1) With 686 N (70 kgf, 154 lb) loaded in the direction shown in the figure, measure dimension l_1 .

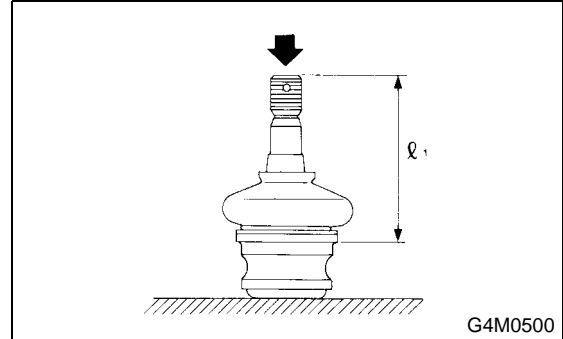

- (2) With 686 N (70 kgf, 154 lb) loaded in the opposite direction shown in the figure, measure dimension l_2 .

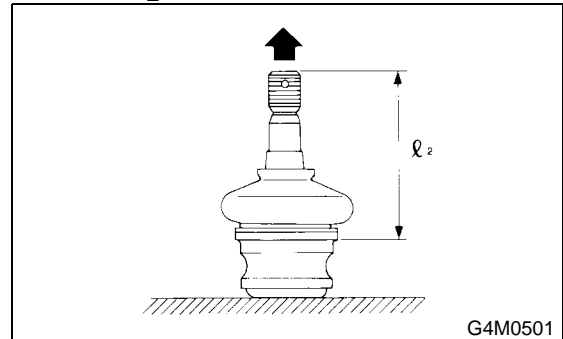

- (3) Calculate plays from the following formula.

$$S = l_2 - l_1$$

- (4) When plays are larger than the following value, replace with a new one.

FRONT BALL JOINT

Specified play for replacement: S
Less than 0.3 mm (0.012 in)

- 2) When play is smaller than the specified value, visually inspect the dust cover.
- 3) The ball joint and cover that have been removed must be checked for wear, damage or cracks, and any defective part must be replaced.
- 4) If the dust cover is damaged, replace with the new ball joint.

5. Front Strut

A: REMOVAL

- 1) Remove wheel.
- 2) Remove bolt securing brake hose from strut.

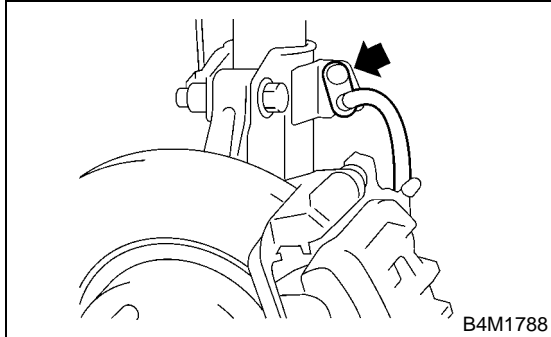

- 3) Scribe an alignment mark on the camber adjusting bolt which secures strut to housing.
- 4) Remove bolt securing the ABS sensor harness.

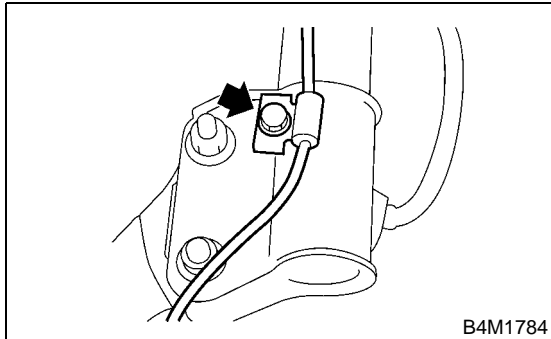

- 5) Remove two bolts securing housing to strut.

CAUTION:
While holding head of adjusting bolt, loosen self-locking nut.

- 6) Remove the three nuts securing strut mount to body.

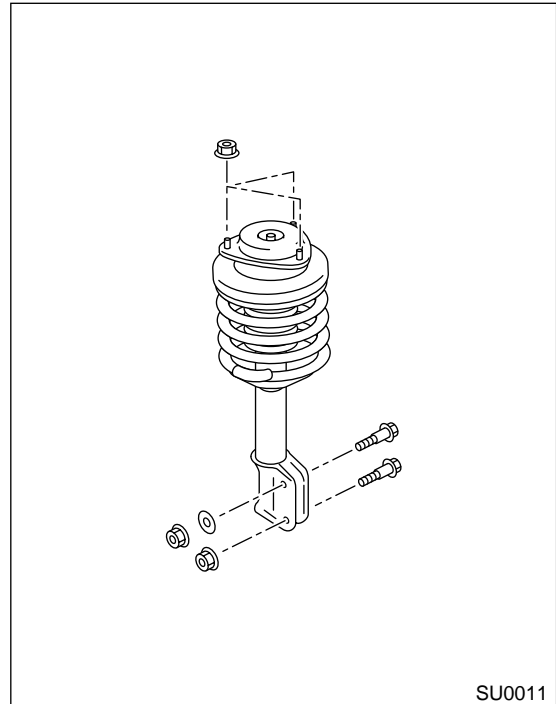

FRONT STRUT

FRONT SUSPENSION

B: INSTALLATION

1) Install strut mount at upper side of strut to body and tighten with nuts.

Tightening torque:

20 N·m (2.0 kgf-m, 14.5 ft-lb)

2) Position aligning mark on camber adjustment bolt with aligning mark on lower side of strut.

CAUTION:

- While holding head of adjusting bolt, tighten self-locking nut.
- Be sure to use new self-locking nut.

Tightening torque:

175 N·m (17.8 kgf-m, 129 ft-lb)

3) Install ABS sensor harness to strut.

Tightening torque:

33 N·m (3.4 kgf-m, 24.3 ft-lb)

4) Install bolts which secure brake hose to strut.

Tightening torque:

33 N·m (3.4 kgf-m, 24.3 ft-lb)

5) Install wheels.

NOTE:

Check wheel alignment and adjust if necessary.

C: DISASSEMBLY

1) Using a coil spring compressor, compress coil spring.

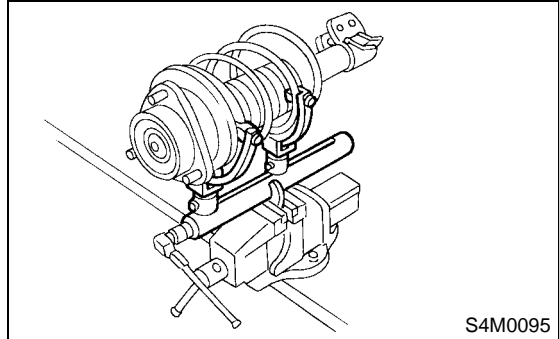

2) Using ST, remove self-locking nut.

ST 927760000 STRUT MOUNT SOCKET

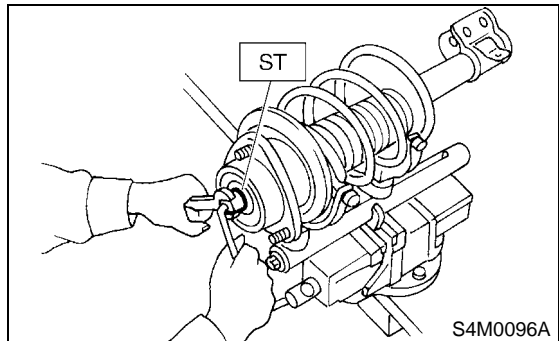

3) Remove strut mount, upper spring seat and rubber seat from strut.

4) Gradually decreasing compression force, and remove coil spring.

5) Remove dust cover and helper spring.

D: ASSEMBLY

1) Before installing coil spring, strut mount, etc., on the strut, check for the presence of air in the dampening force generating mechanism of the strut since air prevents proper dampening force from being produced.

2) Checking for the presence of air

(1) Place the strut vertically with the piston rod facing up.

(2) Move the piston rod to the center of its entire stroke.

(3) While holding the piston rod end with fingertips, move the rod up and down.

(4) If the piston rod moves at least 10 mm (0.39 in) in the former step, purge air from the strut.

3) Air purging procedure

(1) Place the strut vertically with the piston rod facing up.

(2) Fully extend the piston rod.

(3) With the piston rod fully extended, place the piston rod side down. The strut must stand vertically.

(4) Fully contract the piston rod.

(5) Repeat 3 or 4 times from the first step.

NOTE:

After completely purging air from the strut, be sure to place the strut with the piston rod facing up. If it is laid down, check for entry of air in the strut as outlined under "Checking for the presence of air".

4) Using a coil spring compressor, compress the coil spring.

NOTE:

Make sure that the vertical installing direction of coil spring is as shown in figure.

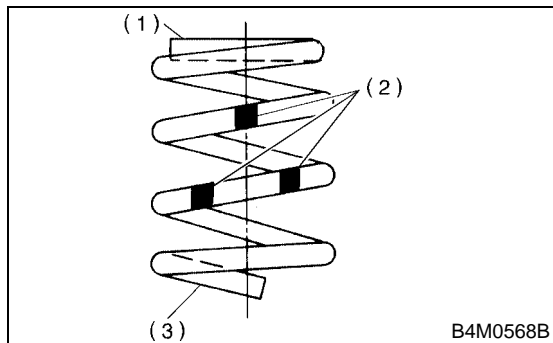

- (1) Flat (top side)
- (2) Identification paint
- (3) Inclined (bottom side)

5) Set the coil spring correctly so that its end face fits well into the spring seat as shown.

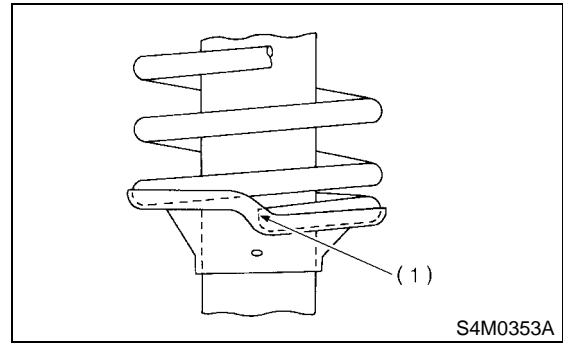

6) Install helper and dust cover to the piston rod.

7) Pull the piston rod fully upward, and install rubber seat and spring seat.

NOTE:

Ensure that upper spring seat is positioned as shown in figure.

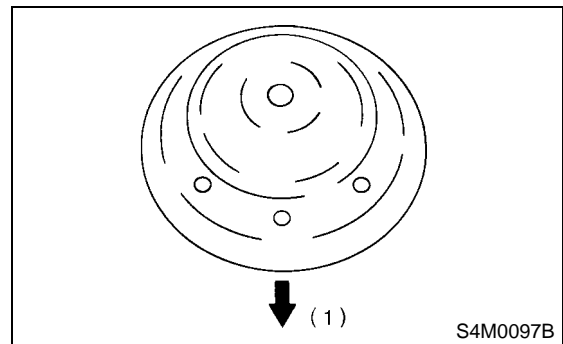

- (1) Outside of body

8) Install strut mount to the piston rod, and tighten the self-locking nut temporarily.

CAUTION:

Be sure to use a new self-locking nut.

9) Using hexagon wrench to prevent strut rod from turning, tighten self-locking nut with ST.

ST 927760000 STRUT MOUNT SOCKET

Tightening torque:

54 N·m (5.5 kgf·m, 39.8 ft·lb)

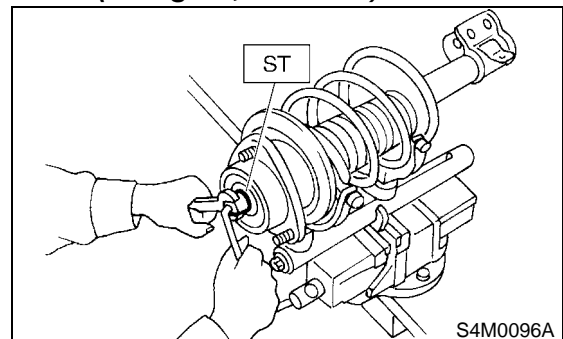

10) Loosen the coil spring carefully.

FRONT STRUT

FRONT SUSPENSION

E: INSPECTION

Check the disassembled parts for cracks, damage and wear, and replace with new parts if defective.

1. DAMPER STRUT

- 1) Check for oil leakage.
- 2) Move the piston rod up and down to check it operates smoothly without any binding.
- 3) Play of piston rod

- Measure the play as follows:

Fix outer shell and fully extend the rod. Set a dial gauge at the end of the rod: L [10 mm (0.39 in)], then apply a force of W [20 N (2 kgf, 4 lb)] to threaded portion. With the force of 20 N (2 kgf, 4 lb) applied, read dial gauge indication: P₁. Apply a force of 20 N (2 kgf, 4 lb) in the opposite direction of "W", then read dial gauge indication: P₂.

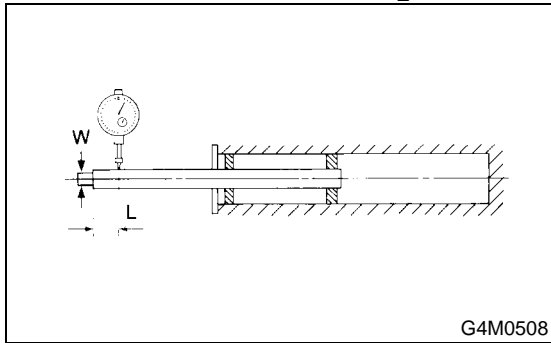

The free play is determined by the following equation:

$$\text{Play} = P_1, P_2$$

Limit of play:

Less than 0.8 mm (0.031 in)

If the play is greater, replace the strut.

2. STRUT MOUNT

Check rubber part for creep, cracks and deterioration, and replace it with new one if defective.

3. DUST COVER

If any cracks or damage are found, replace it with a new one.

4. COIL SPRING

One having permanent strain should be replaced with a new one. When vehicle posture is uneven, although there are no considerable reasons like tire puncture, uneven loading, etc., check coil spring for its free length referring to specifications, cracks, etc., and replace it with a new one if defective.

5. HELPER

Replace it with new one if cracked or damaged.

F: DISPOSAL

CAUTION:

- On struts which have "GAS FILLED" marked on outer housing under spring seat, completely discharge gas before disposing, following the methods below.
- Do not disassemble strut damper or place into a fire.
- Drill holes before disposing of gas filled struts.
- Before handling gas filled struts, be sure to wear goggles to protect eyes from gas, oil and/or filings.

**GAS FILLED
DO NOT OPEN
DO NOT HEAT**

B4M1201

- 1) Place gas filled strut on a flat and level surface with piston rod fully extended.
- 2) Using a 2 to 3 mm (0.08 to 0.12 in) dia. drill, make holes in areas shown in the figure.

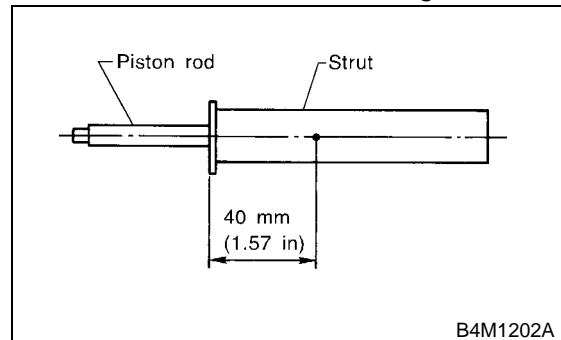

6. Front Stabilizer

A: REMOVAL

- 1) Jack-up the front part of the vehicle and support it with safety stand (rigid racks).
- 2) Remove jack-up plate from lower part of cross-member.
- 3) Remove sub frame.
- 4) Remove bolts which secure stabilizer to cross-member.

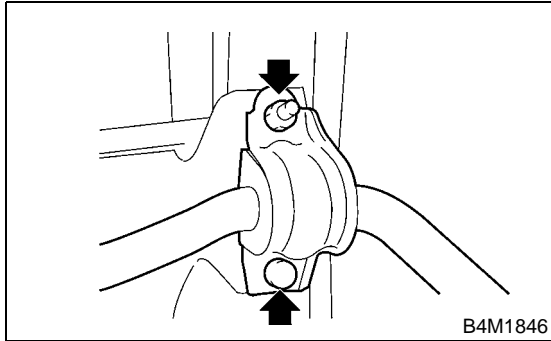

- 5) Remove bolts which secure stabilizer link to front transverse link.

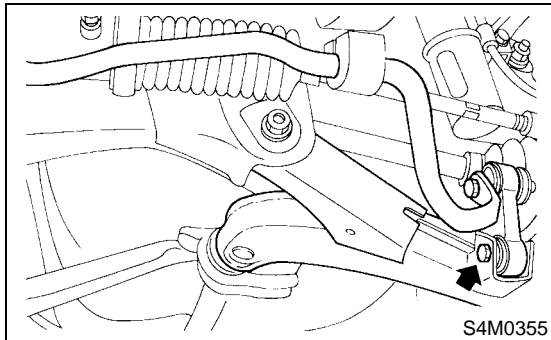

B: INSTALLATION

- 1) Install in the reverse order of removal.

NOTE:

- Install bushing (on front crossmember side) while aligning it with paint mark on stabilizer.
- Ensure that bushing and stabilizer have the same identification colors when installing.

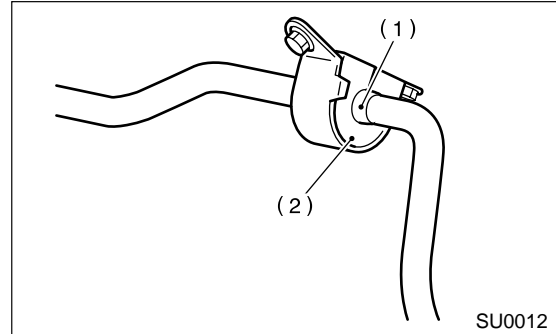

(1) Mark stamped on stabilizer

(2) Bushing identification color

- 2) Always tighten rubber bushing location when wheels are in full contact with the ground and vehicle is curb weight.

Tightening torque (Sedan turbo model):

Jack-up plate to crossmember:

20 N·m (2.0 kgf-m, 14.5 ft-lb)

Stabilizer link to front transverse link:

45 N·m (4.6 kgf-m, 33 ft-lb)

Stabilizer to crossmember:

25 N·m (2.5 kgf-m, 18.1 ft-lb)

Tightening torque (Except sedan turbo model):

Jack-up plate to crossmember:

20 N·m (2.0 kgf-m, 14.5 ft-lb)

Stabilizer link to front transverse link:

30 N·m (3.1 kgf-m, 22 ft-lb)

Stabilizer to crossmember:

25 N·m (2.5 kgf-m, 18.1 ft-lb)

C: INSPECTION

- 1) Check bushing for cracks, fatigue or damage.
- 2) Check stabilizer link for deformities, cracks, or damage, and bushing for protrusions from the hole of stabilizer link.

FRONT CROSSMEMBER

FRONT SUSPENSION

7. Front Crossmember

A: REMOVAL

- 1) Disconnect ground terminal from battery.
- 2) Lift-up vehicle and remove front tires and wheels.
- 3) Remove sub frame.
- 4) Remove both stabilizer and jack-up plate.

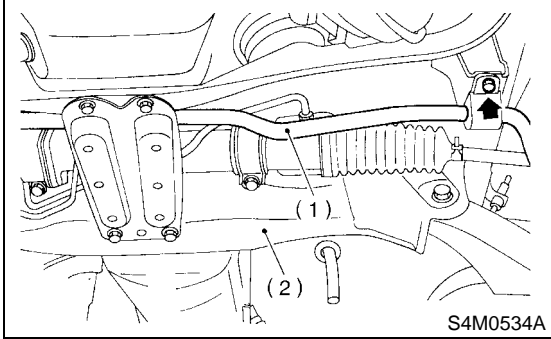

- (1) Front stabilizer
- (2) Front crossmember

- 5) Disconnect tie-rod end from housing.
- 6) Remove front exhaust pipe.
- 7) Remove front transverse link from front crossmember and body.

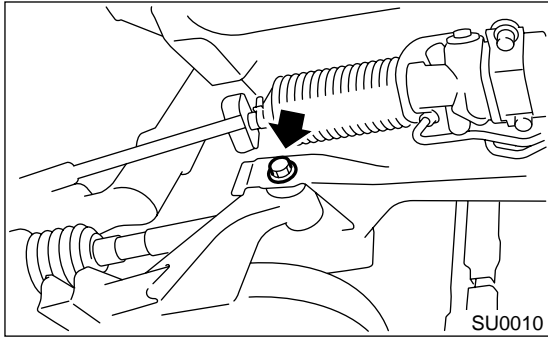

- 8) Remove nuts attaching engine mount cushion rubber to crossmember.
- 9) Remove steering universal joint.
- 10) Disconnect power steering pipe from steering gear box.
- 11) Lift engine by approx. 10 mm (0.39 in) by using chain block.
- 12) Support crossmember with a jack, remove nuts securing crossmember to body and lower crossmember gradually along with steering gearbox.

CAUTION:

When removing crossmember downward, be careful that tie-rod end does not interfere with SFJ boot.

B: INSTALLATION

- 1) Install in the reverse order of removal.

CAUTION:

Always tighten rubber bushing when wheels are in full contact with the ground and vehicle is curb weight.

Tightening torque:

Transverse link bushing to crossmember:

100 N·m (10.2 kgf-m, 74 ft-lb)

Stabilizer to bushing:

25 N·m (2.5 kgf-m, 18.1 ft-lb)

Tie-rod end to housing:

27.0 N·m (2.75 kgf-m, 19.9 ft-lb)

Front cushion rubber to crossmember:

85 N·m (8.7 kgf-m, 62.7 ft-lb)

Universal joint to pinion shaft:

24 N·m (2.4 kgf-m, 17.4 ft-lb)

Crossmember to body:

100 N·m (10.2 kgf-m, 74 ft-lb)

- 2) Purge air from power steering system.

NOTE:

Check wheel alignment and adjust if necessary.

C: INSPECTION

Check crossmember for wear, damage and cracks, and correct or replace if defective.

8. General Diagnostic Table

A: INSPECTION

1. IMPROPER VEHICLE POSTURE OR IMPROPER WHEEL ARCH HEIGHT

| Possible causes | Countermeasures |
|--|----------------------------|
| (1) Permanent distortion or breakage of coil spring | Replace. |
| (2) Unsmooth operation of damper strut and/or shock absorber | Replace. |
| (3) Installation of wrong strut and/or shock absorber | Replace with proper parts. |
| (4) Installation of wrong coil spring | Replace with proper parts. |

2. POOR RIDE COMFORT

1) Large rebound shock

2) Rocking of vehicle continues too long after running over bump and/or hump.

3) Large shock in bumping

| Possible causes | Countermeasures |
|--|---|
| (1) Breakage of coil spring | Replace. |
| (2) Overinflation pressure of tire | Adjust. |
| (3) Improper wheel arch height | Adjust or replace coil springs with new ones. |
| (4) Fault in operation of damper strut and/or shock absorber | Replace. |
| (5) Damage or deformation of strut mount and/or shock absorber mount | Replace. |
| (6) Unsuitability of maximum and/or minimum length of damper strut and/or shock absorber | Replace with proper parts. |
| (7) Deformation or loss of bushing | Replace. |
| (8) Deformation or damage of helper in strut assembly and/or shock absorber | Replace. |
| (9) Oil leakage of damper strut and/or shock absorber | Replace. |

3. NOISE

| Possible causes | Countermeasures |
|--|------------------------------------|
| (1) Wear or damage of damper strut and/or shock absorber component parts | Replace. |
| (2) Loosening of suspension link installing bolt | Retighten to the specified torque. |
| (3) Deformation or loss of bushing | Replace. |
| (4) Unsuitability of maximum and/or minimum length of damper strut and/or shock absorber | Replace with proper parts. |
| (5) Breakage of coil spring | Replace. |
| (6) Wear or damage of ball joint | Replace. |
| (7) Deformation of stabilizer clamp | Replace. |

GENERAL DIAGNOSTIC TABLE

FRONT SUSPENSION
