

**CHASSIS SECTION**

This service manual has been prepared to provide SUBARU service personnel with the necessary information and data for the correct maintenance and repair of SUBARU vehicles.

This manual includes the procedures for maintenance, disassembling, reassembling, inspection and adjustment of components and diagnostics for guidance of experienced mechanics.

Please peruse and utilize this manual fully to ensure complete repair work for satisfying our customers by keeping their vehicle in optimum condition. When replacement of parts during repair work is needed, be sure to use SUBARU genuine parts.

All information, illustration and specifications contained in this manual are based on the latest product information available at the time of publication approval.

**FRONT SUSPENSION****FS****REAR SUSPENSION****RS****WHEEL AND TIRE SYSTEM****WT****DIFFERENTIALS****DI****TRANSFER CASE****TC****DRIVE SHAFT SYSTEM****DS****ABS****ABS****ABS (DIAGNOSTICS)****ABS****BRAKE****BR****PARKING BRAKE****PB****POWER ASSISTED SYSTEM  
(POWER STEERING)****PS**

# REAR SUSPENSION

# RS

---

	<b>Page</b>
1. General Description .....	2
2. Wheel Alignment .....	10
3. Rear Stabilizer.....	11
4. Rear Trailing Link.....	12
5. Rear Strut.....	16
6. Lateral link.....	18
7. Rear Crossmember .....	22
8. General Diagnostic Table.....	24

# GENERAL DESCRIPTION

## REAR SUSPENSION

### 1. General Description

#### A: SPECIFICATIONS

Item	Sedan		Wagon		OUTBACK
	Turbo	Non-turbo	Turbo	Non-turbo	
Camber (tolerance: $\pm 0^{\circ}45'$ )	$-1^{\circ}30'$	$-1^{\circ}25'$	$-1^{\circ}20'$	$-1^{\circ}15'$	$-1^{\circ}10'$
Toe-in	$-1 \pm 2$ mm ( $-0.039 \pm 0.079$ in) Each toe-in angle: $\pm 0^{\circ}07'30''$				
Wheel arch height [tolerance: $\pm 12$ mm ( $\pm 0.47$ in)]	376 mm (14.80 in)	381 mm (15.0 in)	376 mm (14.80 in)	381 mm (15.0 in)	386 mm (15.20 in)
Thrust angle	$0^{\circ} \pm 20'$				
Diameter of stabilizer	20 mm (0.79 in)	—	17 mm (0.67 in)	—	

**NOTE:**

- Front and rear toe-ins and front camber can be adjusted. If toe-in or camber tolerance exceeds specifications, adjust toe-in and camber to the middle value of specification.
- The other items indicated in the specification table cannot be adjusted. If the other items exceeds specifications, check suspension parts and connections for deformities; replace with new ones as required.

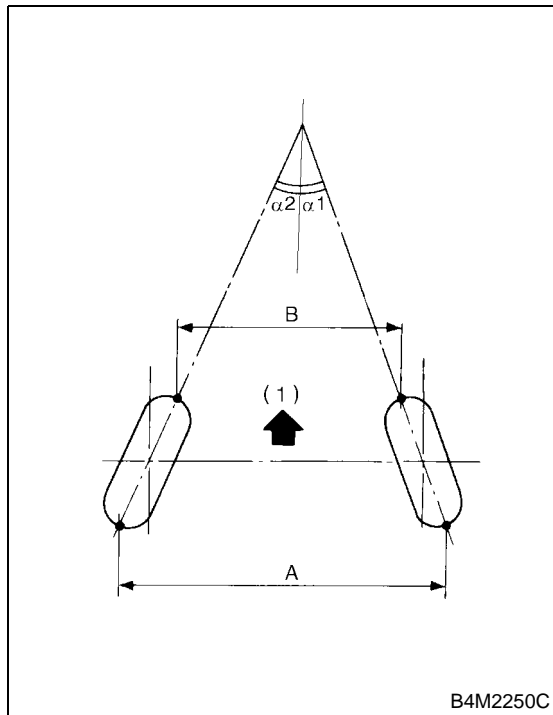

(1) Front

A – B = Positive: Toe-in, Negative: Toe-out

$\alpha 1, \alpha 2$ : Each toe-in angle



# GENERAL DESCRIPTION

## REAR SUSPENSION

### B: COMPONENT

#### 1. REAR SUSPENSION

• AWD model

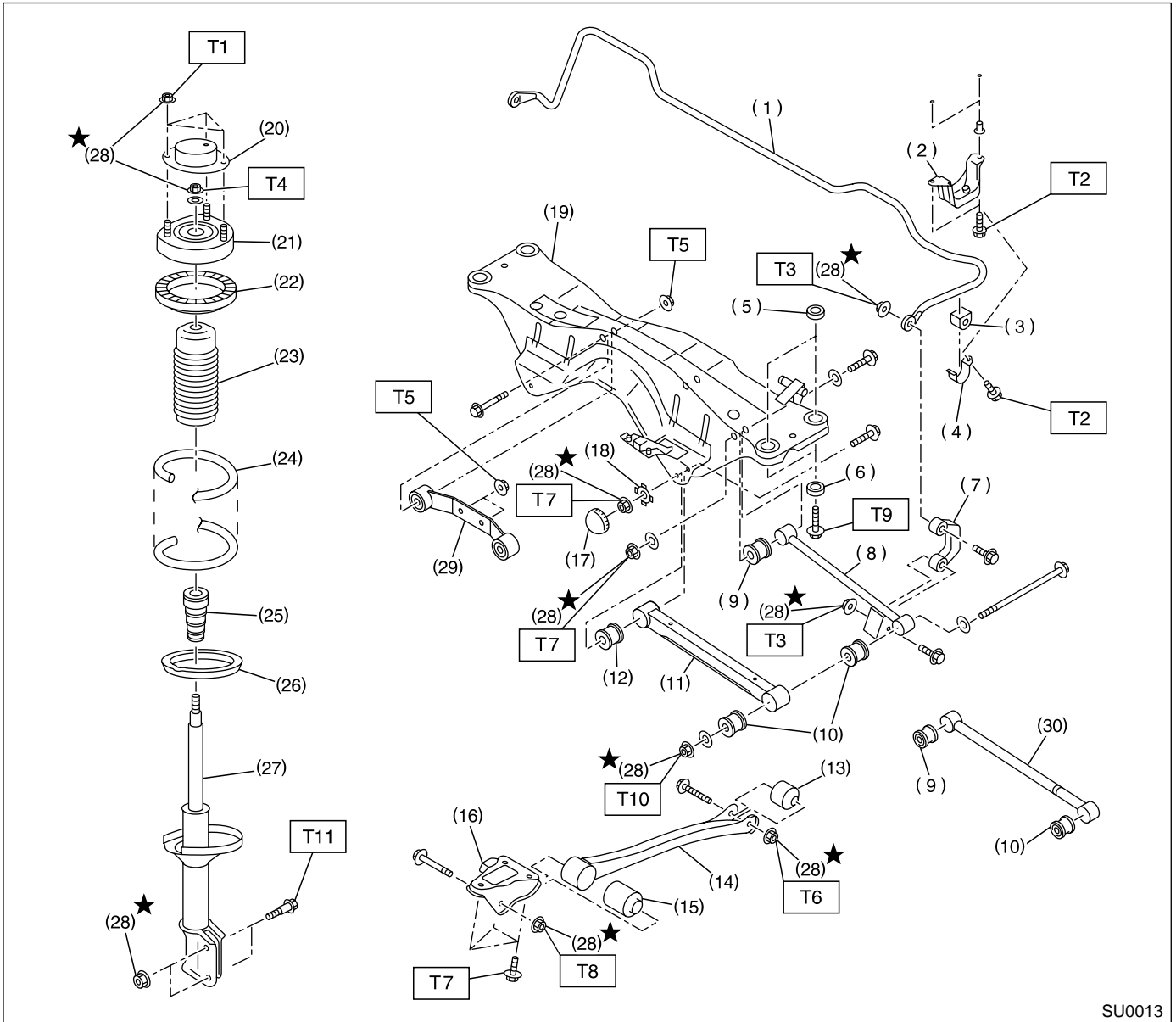

SU0013

# GENERAL DESCRIPTION

## REAR SUSPENSION

---

(1) Stabilizer (Turbo model)	(16) Trailing link bracket	<b><i>Tightening torque: N·m (kgf-m, ft-lb)</i></b>
(2) Stabilizer bracket (Turbo model)	(17) Cap (Protection)	<b><i>T1: 20 (2.0, 14.5)</i></b>
(3) Stabilizer bushing (Turbo model)	(18) Washer	<b><i>T2: 25 (2.5, 18.1)</i></b>
(4) Clamp (Turbo model)	(19) Rear crossmember	<b><i>T3: 45 (4.6, 33.2)</i></b>
(5) Floating bushing	(20) Strut mount cap	<b><i>T4: 55 (5.6, 41)</i></b>
(6) Stopper	(21) Strut mount	<b><i>T5: 70 (7.1, 52)</i></b>
(7) Stabilizer link (Turbo model)	(22) Rubber seat upper	<b><i>T6: 90 (9.2, 66)</i></b>
(8) Rear lateral link (Turbo model)	(23) Dust cover	<b><i>T7: 100 (10.2, 74)</i></b>
(9) Bushing (C)	(24) Coil spring	<b><i>T8: 115 (11.7, 85)</i></b>
(10) Bushing (A)	(25) Helper	<b><i>T9: 130 (13.3, 96)</i></b>
(11) Front lateral link	(26) Rubber seat lower	<b><i>T10: 135 (13.8, 100)</i></b>
(12) Bushing (B)	(27) Damper strut	<b><i>T11: 220 (22.4, 162)</i></b>
(13) Trailing link rear bushing	(28) Self-locking nut	
(14) Trailing link	(29) Rear differential member rear	
(15) Trailing link front bushing	(30) Rear lateral link (Non-turbo model)	

---

# GENERAL DESCRIPTION

## REAR SUSPENSION

### • FWD model

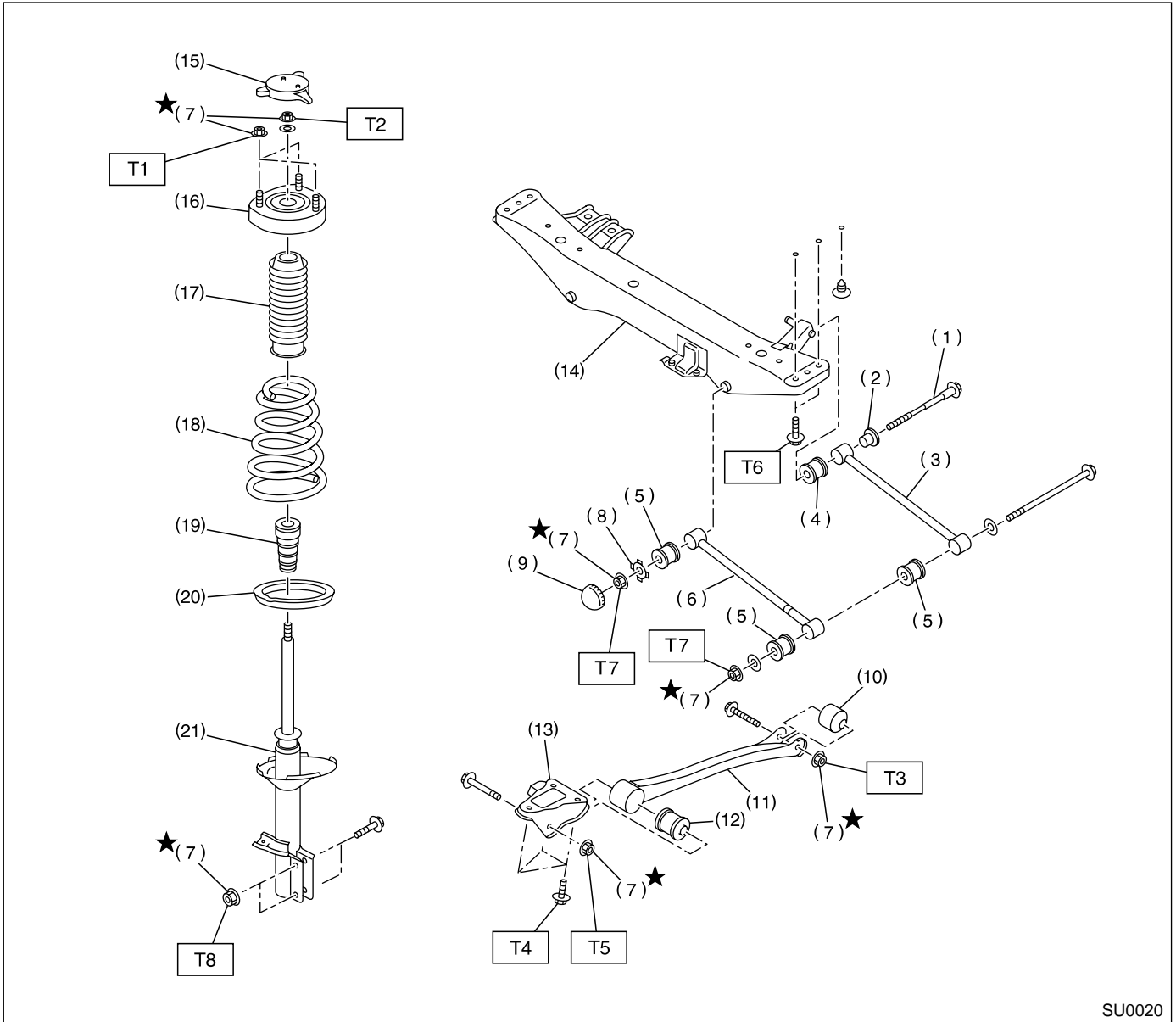

SU0020

- |                                 |                                  |
|---------------------------------|----------------------------------|
| (1) Adjusting bolt              | (12) Trailing link front bushing |
| (2) Adjusting wheel             | (13) Trailing link bracket       |
| (3) Rear lateral link           | (14) Crossmember                 |
| (4) Bushing (D)                 | (15) Cap                         |
| (5) Bushing (A)                 | (16) Strut mount                 |
| (6) Front lateral link          | (17) Dust cover                  |
| (7) Self-locking nut            | (18) Coil spring                 |
| (8) Washer                      | (19) Helper                      |
| (9) Cap                         | (20) Rubber seat lower           |
| (10) Trailing link rear bushing | (21) Damper strut                |
| (11) Trailing link              |                                  |

#### **Tightening torque: N·m (kgf·m, ft·lb)**

**T1: 20 (2.0, 14.5)**

**T2: 55 (5.6, 41)**

**T3: 90 (9.2, 66)**

**T4: 100 (10.2, 74)**

**T5: 115 (11.7, 85)**

**T6: 130 (13.3, 96)**

**T7: 135 (13.8, 100)**

**T8: 220 (22.4, 162)**

### **C: CAUTION**

- Wear working clothing, including a cap, protective goggles, and protective shoes during operation.
- Remove contamination including dirt and corrosion before removal, installation or disassembly.
- Keep the disassembled parts in order and protect them from dust or dirt.
- Before removal, installation or disassembly, be sure to clarify the failure. Avoid unnecessary removal, installation, disassembly, and replacement.
- Use SUBARU genuine grease etc. or the equivalent. Do not mix grease etc. with that of another grade or from other manufacturers.
- Be sure to tighten fasteners including bolts and nuts to the specified torque.
- Place shop jacks or safety stands at the specified points.
- Apply grease onto sliding or revolution surfaces before installation.
- Before installing O-rings or snap rings, apply sufficient amount of grease to avoid damage and deformation.
- Before securing a part on a vice, place cushioning material such as wood blocks, aluminum plate, or shop cloth between the part and the vice.
- Before disposing shock absorbers, be sure to bleed gas completely. Also, do not throw away in fire.



# GENERAL DESCRIPTION

## REAR SUSPENSION

### D: PREPARATION TOOL

#### 1. SPECIAL TOOLS

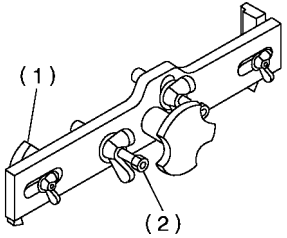
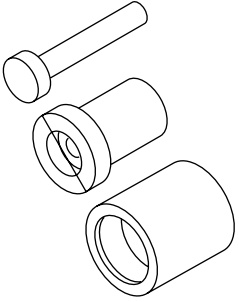
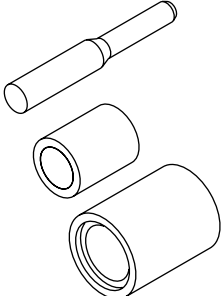
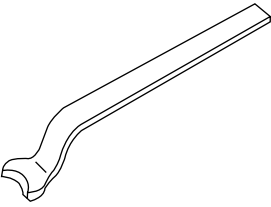
ILLUSTRATION	TOOL NUMBER	DESCRIPTION	REMARKS
 <p style="text-align: right;">B4M2378A</p>	927380002	ADAPTER	Used as an adapter for camber & caster gauge when measuring camber and caster. (1) 28199AC000 PLATE (2) 28199AC010 BOLT
 <p style="text-align: right;">SU0014</p>	927720000	INSTALLER & REMOVER	Used for replacing front bushing.
 <p style="text-align: right;">SU0015</p>	927730000	INSTALLER & REMOVER	Used for replacing rear bushing.
 <p style="text-align: right;">SU0016</p>	28099PA100	REMOVER	Used for removing DOJ.

# GENERAL DESCRIPTION

REAR SUSPENSION

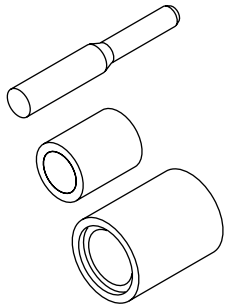
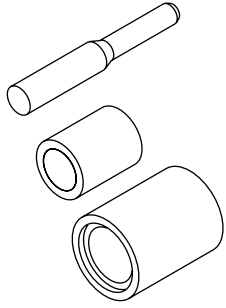
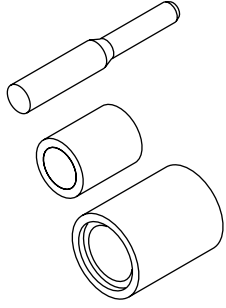
ILLUSTRATION	TOOL NUMBER	DESCRIPTION	REMARKS
 <p style="text-align: right;">SU0015</p>	927710000	INSTALLER & REMOVER	Used for replacing lateral link bushing.
 <p style="text-align: right;">SU0015</p>	92770000	INSTALLER & REMOVER	Used for replacing lateral link bushing.
 <p style="text-align: right;">SU0015</p>	927690000	HELPER SOCKET WRENCH	Used for replacing lateral link bushing.

## 2. GENERAL PURPOSE TOOLS

TOOL NAME	REMARKS
Alignment gauge	Used for wheel alignment measurement.
Turning radius gauge	Used for wheel alignment measurement.
Toe-in gauge	Used for toe-in measurement.
Transmission jack	Used for suspension assembly/disassembly.
Bearing puller	Used for removing bushings.

## 2. Wheel Alignment

### A: INSPECTION

#### NOTE:

The front and rear wheel alignment must be measured and/or adjusted at once to obtain accuracy. Measure and/or adjust the rear wheel alignment together with the front. Follow the procedure in "FS" section "Wheel Alignment" for measurement and/or adjustment of wheel alignment. <Ref. to FS-8, INSPECTION, Wheel Alignment.>

## 3. Rear Stabilizer

### A: REMOVAL

- 1) Jack-up the rear part of the vehicle, support it with safety stands (rigid racks).
- 2) Remove bolts which secure stabilizer link to rear lateral link.

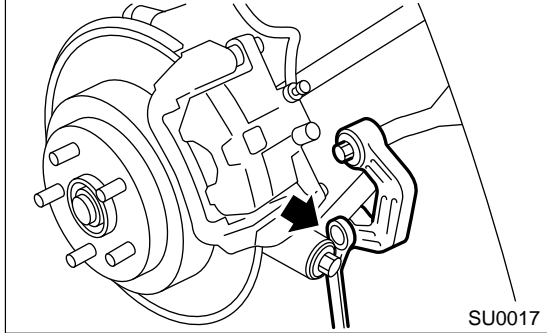

- 3) Remove bolt and nut which secure stabilizer to stabilizer bracket.

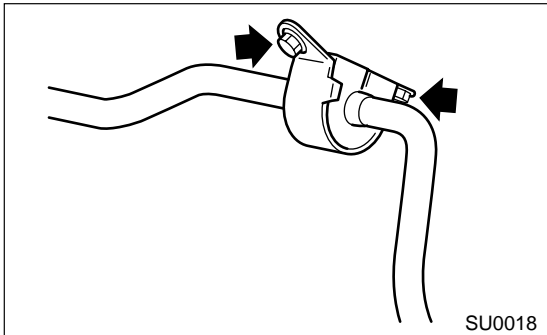

### B: INSTALLATION

- 1) Install in the reverse order of removal.

#### NOTE:

- Install bushing while aligning it with paint mark on stabilizer.
- Ensure that bushing and stabilizer have the same identification colors when installing.

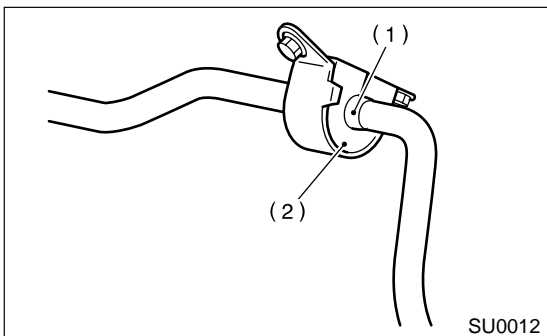

- (1) Mark stamped on stabilizer
- (2) Bushing identification color

- 2) Always tighten rubber bushing location when wheels are in full contact with the ground and vehicle is curb weight.

#### Tightening torque:

**Stabilizer link to rear lateral link**

**45 N·m (4.6 kgf-m, 33.2 ft-lb)**

**Stabilizer to stabilizer bracket**

**25 N·m (2.5 kgf-m, 18.1 ft-lb)**

### C: INSPECTION

- 1) Check bushing for cracks, fatigue or damage.
- 2) Check stabilizer links for deformities, cracks, or damage, and bushing for protrusions from the hole of stabilizer link.

# REAR TRAILING LINK

## REAR SUSPENSION

### 4. Rear Trailing Link

#### A: REMOVAL

- 1) Loosen rear wheel nuts.
- 2) Jack-up vehicle, support it with safety stands (rigid racks) and remove rear wheels.
- 3) Remove both rear parking brake clamp and ABS sensor harness. (Models equipped with ABS)
- 4) Remove bolt which secure trailing link to trailing link bracket.

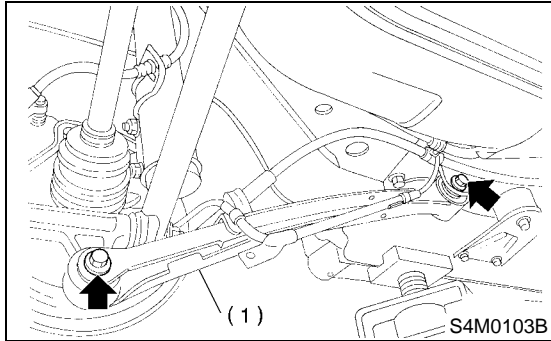

(1) Trailing link

- 5) Remove bolt which secure trailing link to rear housing.

#### B: INSTALLATION

Install in the reverse order of removal.

#### CAUTION:

**Always tighten rubber bushing location when wheels are in full contact with the ground and vehicle is at curb weight condition.**

#### NOTE:

Check wheel alignment and adjust if necessary.

## C: DISASSEMBLY

### 1. FRONT BUSHING

Using ST, press front bushing out of place.

ST 927720000 INSTALLER & REMOVER SET

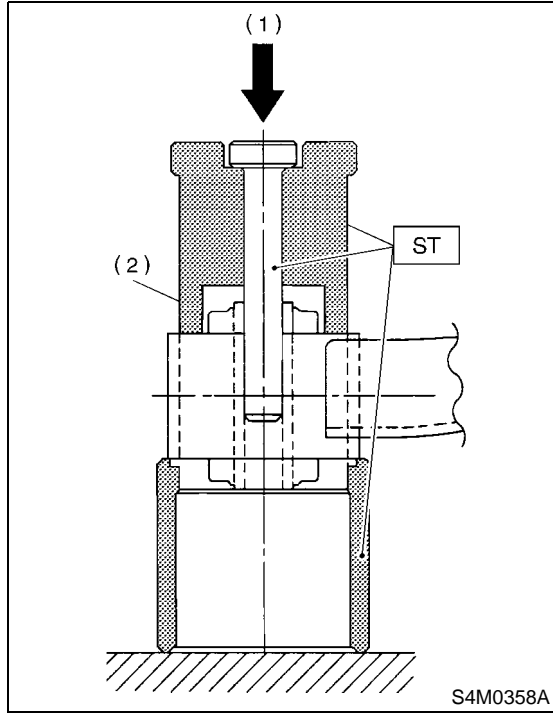

- (1) Press
- (2) Trailing link

### 2. REAR BUSHING

1) Remove housing. <Ref. to DS-24, REMOVAL, Rear Axle.>

2) Using ST, press rear bushing out of place.

ST 927730000 INSTALLER & REMOVER SET

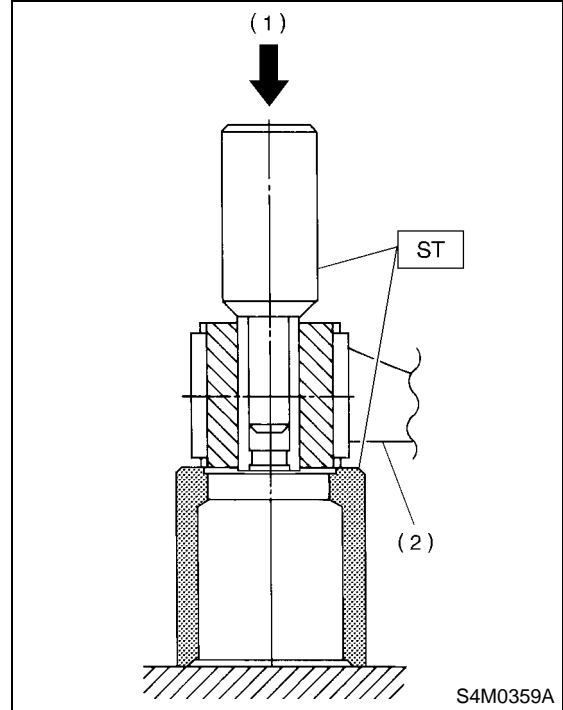

- (1) Press
- (2) Housing

# REAR TRAILING LINK

## REAR SUSPENSION

### D: ASSEMBLY

#### 1. FRONT BUSHING

Using ST, press bushing into trailing link.

ST 927720000 INSTALLER & REMOVER SET

#### CAUTION:

When installing bushing, turn ST plunger upside down and press it until plunger end surface contacts trailing link end surface.

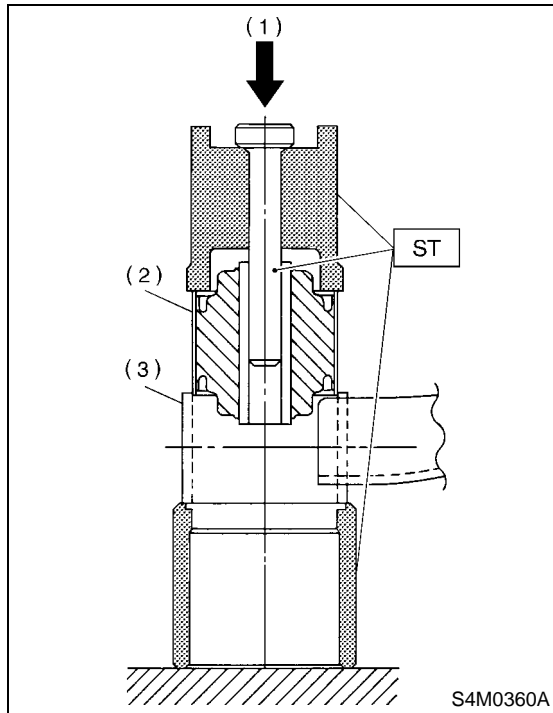

- (1) Press
- (2) Front bushing
- (3) Trailing link

#### 2. REAR BUSHING

1) Using ST, press bushing into trailing link.

ST 927730000 INSTALLER & REMOVER SET

#### NOTE:

If it is difficult to press bushing into trailing link, apply water-diluted TIRE LUBE to the inner surface of ST as a lubricant.

#### SPECIFIED lubricant:

TIRE LUBE : water = 1 : 3

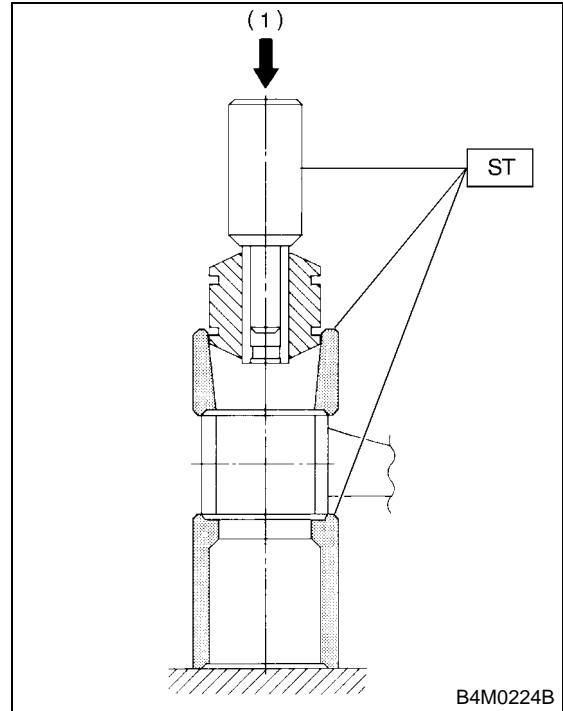

- (1) Press

#### CAUTION:

Install front bushing in the proper direction, as shown in figure.

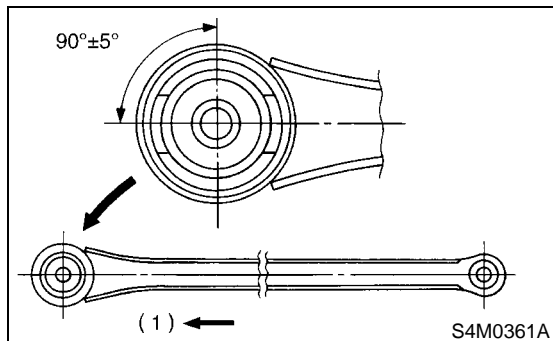

- (1) Front

# REAR TRAILING LINK

REAR SUSPENSION

2) Press ST plunger until bushing flange protrudes beyond trailing link.

ST 927730000 INSTALLER & REMOVER SET

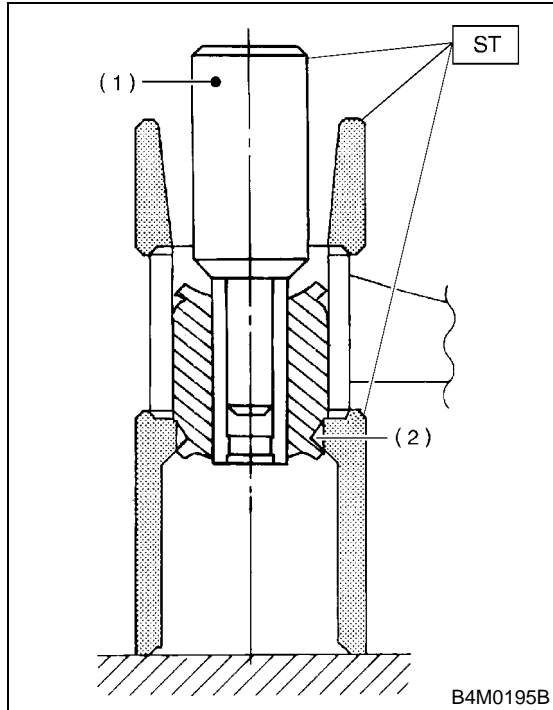

- (1) Plunger
- (2) Flange

3) Turn trailing link upside down. Press ST plunger in the direction opposite that outlines in the former procedure until bushing is correctly positioned in trailing link.

ST 927730000 INSTALLER & REMOVER SET

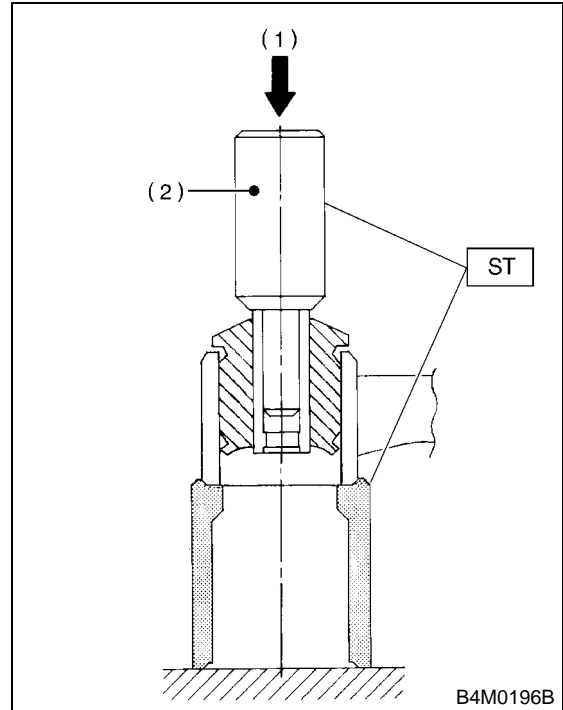

- (1) Press
- (2) Plunger

4) Install housing. <Ref. to DS-27, INSTALLATION, Rear Axle.>

## E: INSPECTION

Check trailing links for bends, corrosion or damage.



# REAR STRUT

## REAR SUSPENSION

### 5. Rear Strut

9) Remove nuts securing strut mount to body.

#### A: REMOVAL

- 1) Depress brake pedal and secure it in that position using a wooden block, etc. (FWD only)
- 2) Remove rear seat cushion and backrest. (Sedan model)
- 3) Remove strut cap of quarter trim. (Wagon model)
- 4) Loosen rear wheel nuts.
- 5) Jack-up vehicle, support it with safety stands (rigid racks) and remove rear wheels.
- 6) FWD models:  
Remove brake hose clip.  
Disconnect brake hose from brake pipe from strut, and disconnect brake pipe from drum brake.

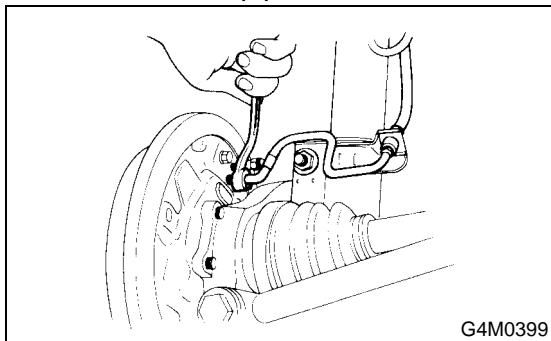

- 7) AWD models:  
Remove brake hose clip and remove brake hose from rear strut.

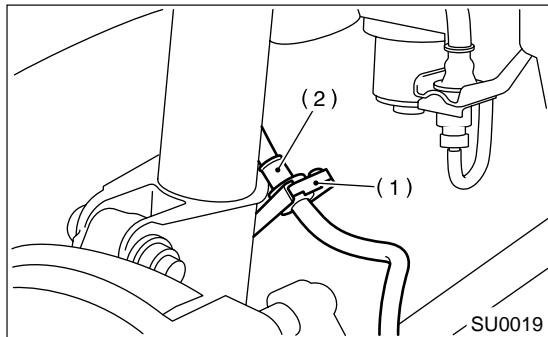

- (1) Brake hose clip
- (2) Brake hose

- 8) Remove bolts which secure rear strut to housing.

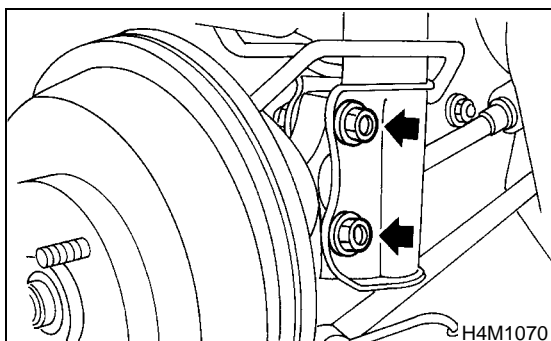

## B: INSTALLATION

1) Tighten self-locking nut used to secure strut mount to car body.

### CAUTION:

**Discard loosened self-locking nut, and replace with a new one.**

### *Tightening torque:*

**20 N·m (2.0 kgf-m, 14.5 ft-lb)**

2) Tighten bolts which secure rear strut to housing.

### *Tightening torque:*

**220 N·m (22.4 kgf-m, 162 ft-lb)**

### CAUTION:

**Discard loosened self-locking nut, and replace with a new one.**

3) AWD model

Install brake hose to lower side of strut, then insert brake hose clip.

FWD model

Connect brake hose to brake pipe.

### *Tightening torque:*

**15 N·m (1.5 kgf-m, 10.8 ft-lb)**

Insert brake hose clip between brake hose and lower side of strut.

### CAUTION:

- Check that hose clip is positioned properly.
- Check brake hose for twisting, or excessive tension.

- (Model equipped with ABS)

**Do not subject ABS sensor harness to excessive tension.**

4) Be sure to bleed air from brake system.

5) Lower vehicle and tighten wheel nut.

### *Tightening torque:*

**90 N·m (9.2 kgf-m, 66 ft-lb)**

6) (Sedan model)

Install rear seat backrest and rear seat cushion.

(Wagon model)

Install strut cap to rear quarter trim.

### NOTE:

Check wheel alignment and adjust if necessary.

## C: DISASSEMBLY

For disassembly of rear strut, refer to procedures outlined under front strut as a guide. <Ref. to FS-20, DISASSEMBLY, Front Strut.>

## D: ASSEMBLY

Refer to Front Strut as a guide for assembly procedures.

<Ref. to FS-21, ASSEMBLY, Front Strut.>

## E: INSPECTION

Refer to Front Strut as a guide for inspection procedures.

<Ref. to FS-22, INSPECTION, Front Strut.>

## F: DISPOSAL

Refer to Front Strut as a guide for disposal procedures.<Ref. to FS-22, DISPOSAL, Front Strut.>

# LATERAL LINK

## REAR SUSPENSION

### 6. Lateral link

#### A: REMOVAL

- 1) Loosen wheel nuts. Lift-up vehicle and remove wheel.
- 2) Remove stabilizers. (Turbo model)
- 3) Remove ABS sensor harness from trailing link. (Models equipped with ABS)
- 4) Remove bolt securing trailing link to housing.

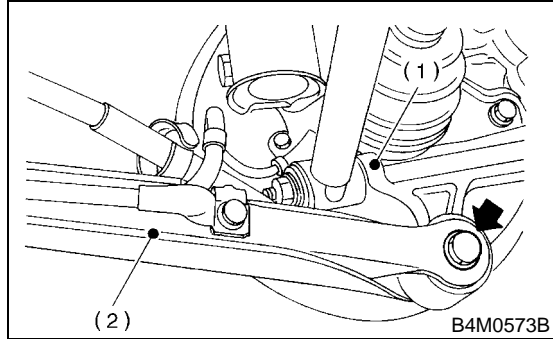

- (1) Rear housing
- (2) Trailing link

- 5) Remove bolts which secure lateral link assembly to rear housing.

- 6) Remove DOJ from rear differential using ST. (2.0 L MT model)

ST 28099PA100 DRIVE SHAFT REMOVER

#### NOTE:

The side spline shaft circlip comes out together with the shaft.

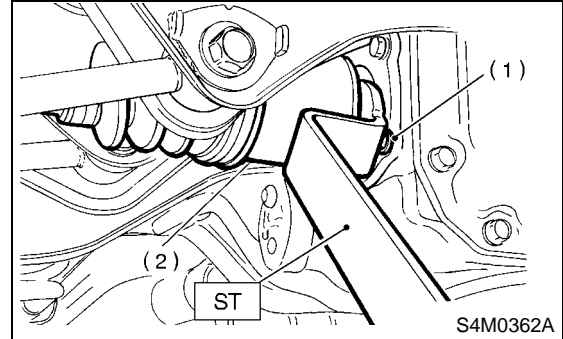

- (1) Bolt
- (2) DOJ

#### CAUTION:

Be careful not to damage side bearing retainer. Always use bolt shown in figure, as supporting point for ST during removal.

- 7) Remove DOJ from rear differential using tire lever.

(Except for 2.0 L MT model)

#### NOTE:

The side spline shaft circlip comes out together with the shaft.

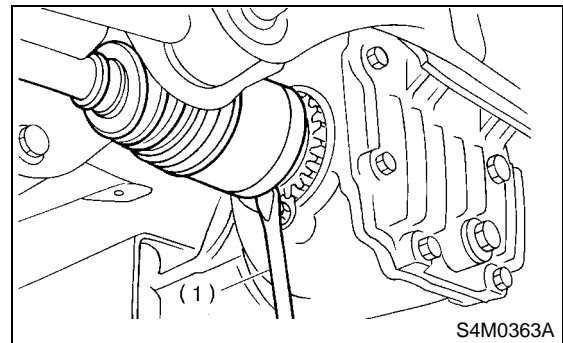

- (1) Tire lever

#### CAUTION:

When removing the DOJ from the rear differential, fit tire lever to the bolt as shown in figure so as not to damage the axle shaft holder.

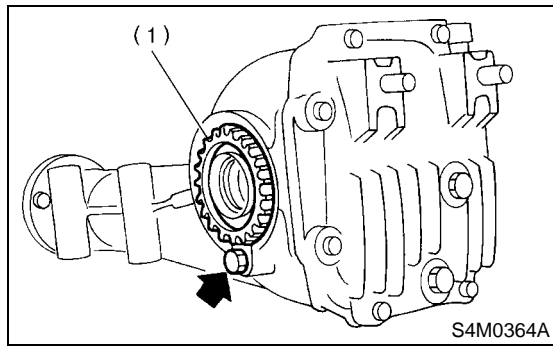

(1) Axle shaft holder

8) Scribe an alignment mark on rear lateral link adjusting bolt and crossmember.

9) Remove bolts securing front and rear lateral links to crossmember, detach lateral links.

**CAUTION:**

To loosen adjusting bolt, always loosen nut while holding the head of adjusting bolt.

**B: INSTALLATION**

Install in the reverse order of removal. Observe the following instructions.

- Installation of DOJ to differential:<Ref. to DS-37, INSTALLATION, Rear Drive Shaft.>

**CAUTION:**

- Do not allow DOJ splines to damage side oil seal.
- Always tighten rubber bushing location when wheels are in full contact with the ground and vehicle is curb weight.
- Tighten nut when installing adjusting bolt.
- Replace self-locking nut and DOJ circlip with new ones.

**NOTE:**

Check wheel alignment and adjust if necessary.

**C: DISASSEMBLY**

Using ST, press bushing out of place.

**NOTE:**

- Using the following table as a guide, verify the type of bushings.
- Select ST according to the type of bushings used.

Bushing	ST:INSTALLER & REMOVER SET
Bushing A	927700000
Bushing B	927690000
Bushing C	927700000
Bushing D	927710000

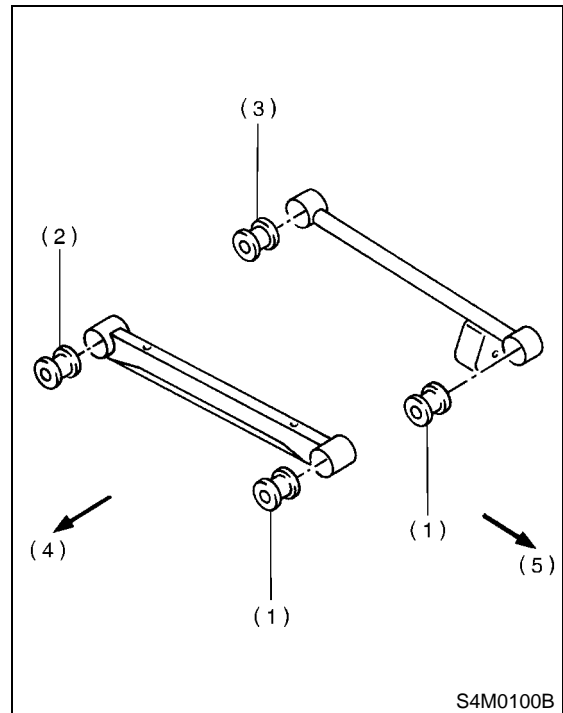

- (1) Bushing A
- (2) FWD: Bushing A, AWD: Bushing B
- (3) FWD: Bushing D, AWD: Bushing C
- (4) Front
- (5) Outside of body

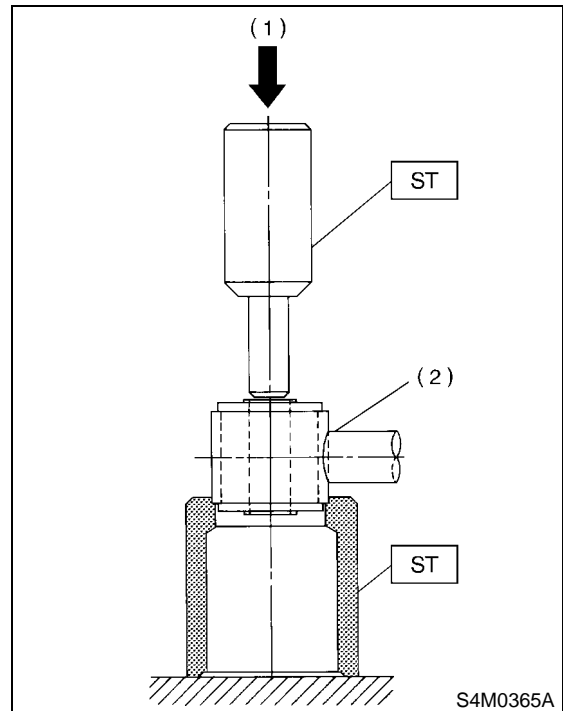

- (1) Press
- (2) Lateral link

# LATERAL LINK

## REAR SUSPENSION

### D: ASSEMBLY

1) Using ST, press bushing into place.

#### CAUTION:

Select ST according to the type of bushings used.

#### NOTE:

- Using the same ST as that used during disassembly.
- If it is difficult to press bushing into trailing link, apply water-diluted TIRE LUBE to the inner surface of ST as a lubricant.

#### Specified lubricant:

**TIRE LUBE : water = 1 : 3**

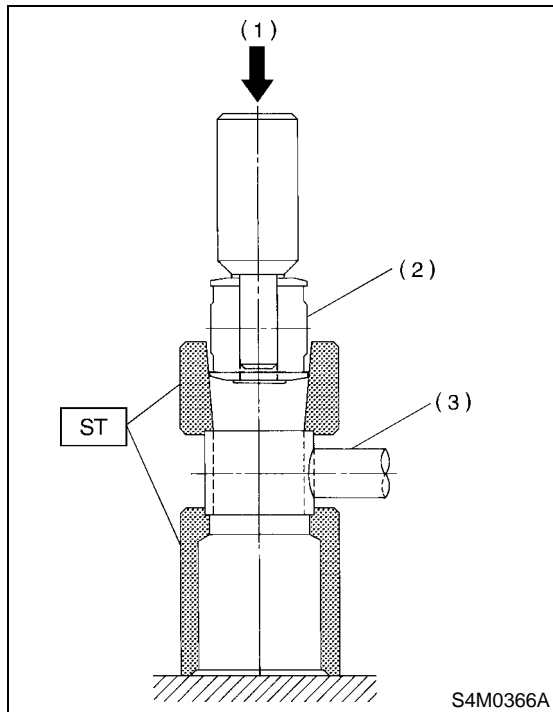

- (1) Press
- (2) Bushing
- (3) Lateral link

2) Press ST plunger until bushing flange protrudes beyond lateral link.

#### NOTE:

Using the same ST as that used during disassembly.

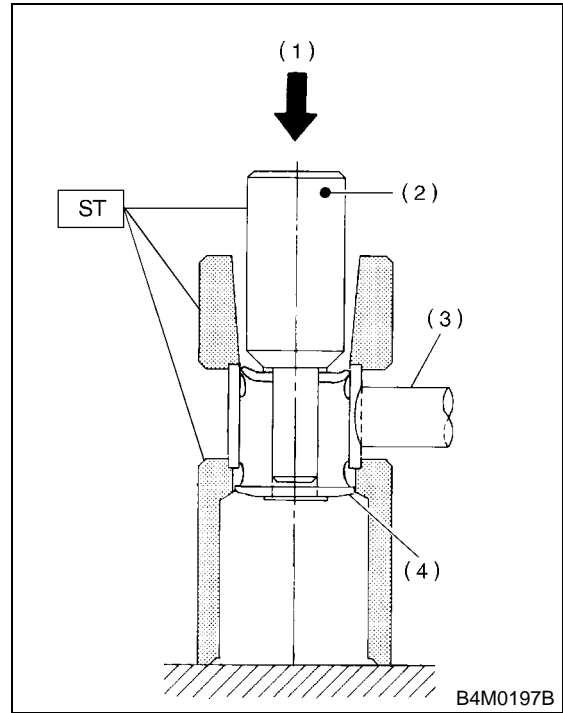

- (1) Press
- (2) Plunger
- (3) Lateral link
- (4) Flange

3) Turn lateral link upside down. Press ST plunger in the direction opposite that outlined in the former procedure until bushing is correctly positioned in trailing link.

**NOTE:**

Using the same ST as that used during disassembly.

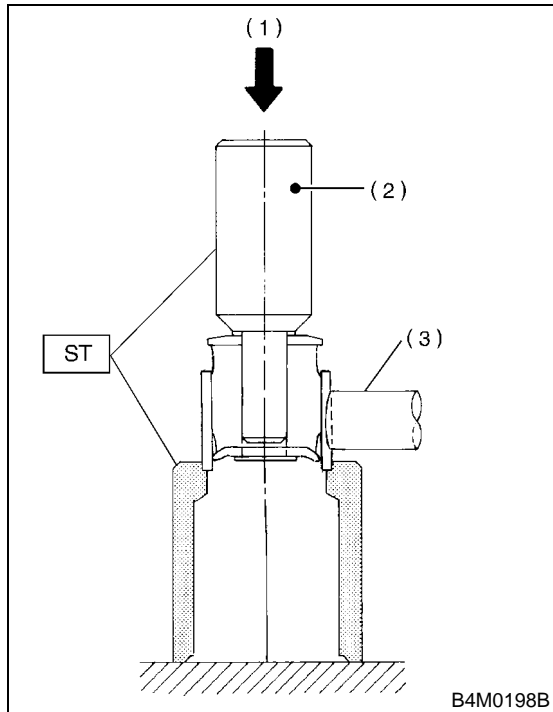

- (1) Press
- (2) Plunger
- (3) Lateral link

### **E: INSPECTION**

Visually check lateral links for damage or bends.

# REAR CROSSMEMBER

## REAR SUSPENSION

### 7. Rear Crossmember

#### A: REMOVAL

##### 1. AWD MODEL

##### CAUTION:

**Do not subject ABS sensor harness to excessive tension. (Models equipped with ABS)**

- 1) Separate front exhaust pipe and rear exhaust pipe.
- 2) Remove rear exhaust pipe and muffler.
- 3) Remove rear differential.

T-type

<Ref. to DI-25, REMOVAL, Rear Differential for T-type.>

VA-type

<Ref. to DI-40, REMOVAL, Rear Differential for VA-type.>

- 4) Place transmission jack under rear crossmember.

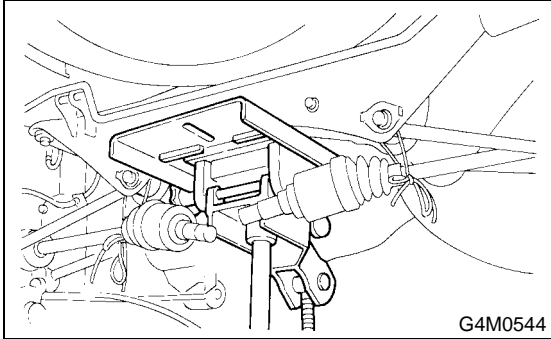

- 5) Remove bolts securing crossmember to vehicle body, and remove crossmember.

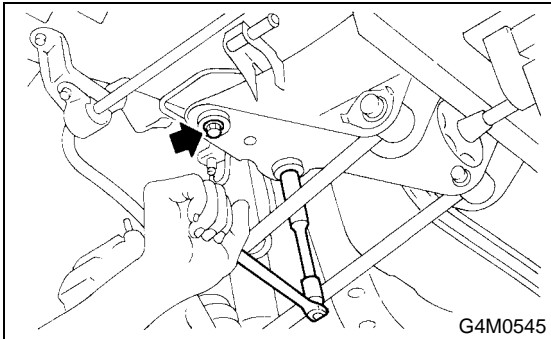

- 6) Scribe an alignment mark on rear lateral link cam bolt and crossmember.

- 7) Remove front and rear lateral links by loosening nuts.

##### 2. FWD MODEL

- 1) Disconnect lateral links from housing.
- 2) Remove rear exhaust pipe and muffler.
- 3) Remove heat-shield cover.
- 4) Remove four bolts securing crossmember to body.

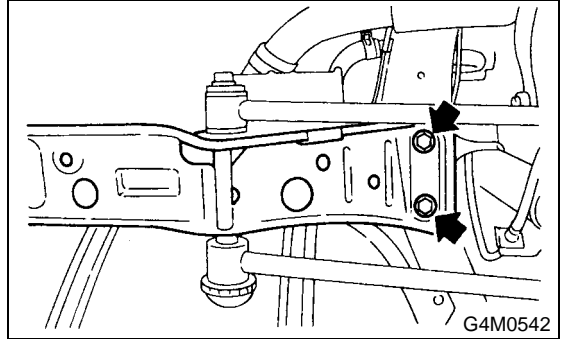

## B: INSTALLATION

### 1. AWD MODEL

- 1) Install in the reverse order of removal.
- 2) For installation and tightening torque of rear differential;  
T-type  
<Ref. to DI-27, INSTALLATION, Rear Differential for T-type.>  
VA-type  
<Ref. to DI-42, INSTALLATION, Rear Differential for VA-type.>
- 3) Always tighten rubber bushing when wheels are in full contact with the ground and vehicle is curb weight.

**NOTE:**

Check wheel alignment and adjust if necessary.

### 2. FWD MODEL

Install in the reverse order of removal.

**CAUTION:**

- **Discard loosened self-locking nut and replace with a new one.**
- **Always tighten nut (not adjusting bolt), when tightening adjusting bolt.**
- **Always tighten rubber bushing when wheels are in full contact with the ground and vehicle is curb weight.**

**NOTE:**

Check wheel alignment and adjust if necessary.

## C: INSPECTION

Check removed parts for wear, damage and cracks, and correct or replace if defective.



# GENERAL DIAGNOSTIC TABLE

## REAR SUSPENSION

### 8. General Diagnostic Table

#### A: INSPECTION

##### 1. IMPROPER VEHICLE POSTURE OR IMPROPER WHEEL ARCH HEIGHT

Possible causes	Countermeasures
(1) Permanent distortion or breakage of coil spring	Replace.
(2) Unsmooth operation of damper strut and/or shock absorber	Replace.
(3) Installation of wrong strut and/or shock absorber	Replace with proper parts.
(4) Installation of wrong coil spring	Replace with proper parts.

##### 2. POOR RIDE COMFORT

- 1) Large rebound shock
- 2) Rocking of vehicle continues too long after running over bump and/or hump.
- 3) Large shock in bumping

Possible causes	Countermeasures
(1) Breakage of coil spring	Replace.
(2) Overinflation pressure of tire	Adjust.
(3) Improper wheel arch height	Adjust or replace coil springs with new ones.
(4) Fault in operation of damper strut and/or shock absorber	Replace.
(5) Damage or deformation of strut mount and/or shock absorber mount	Replace.
(6) Unsuitability of maximum and/or minimum length of damper strut and/or shock absorber	Replace with proper parts.
(7) Deformation or loss of bushing	Replace.
(8) Deformation or damage of helper in strut assembly and/or shock absorber	Replace.
(9) Oil leakage of damper strut and/or shock absorber	Replace.

##### 3. NOISE

Possible causes	Countermeasures
(1) Wear or damage of damper strut and/or shock absorber component parts	Replace.
(2) Loosening of suspension link installing bolt	Retighten to the specified torque.
(3) Deformation or loss of bushing	Replace.
(4) Unsuitability of maximum and/or minimum length of damper strut and/or shock absorber	Replace with proper parts.
(5) Breakage of coil spring	Replace.
(6) Wear or damage of ball joint	Replace.
(7) Deformation of stabilizer clamp	Replace.