

CHASSIS SECTION

This service manual has been prepared to provide SUBARU service personnel with the necessary information and data for the correct maintenance and repair of SUBARU vehicles.

This manual includes the procedures for maintenance, disassembling, reassembling, inspection and adjustment of components and diagnostics for guidance of experienced mechanics.

Please peruse and utilize this manual fully to ensure complete repair work for satisfying our customers by keeping their vehicle in optimum condition. When replacement of parts during repair work is needed, be sure to use SUBARU genuine parts.

All information, illustration and specifications contained in this manual are based on the latest product information available at the time of publication approval.

FRONT SUSPENSION**FS****REAR SUSPENSION****RS****WHEEL AND TIRE SYSTEM****WT****DIFFERENTIALS****DI****TRANSFER CASE****TC****DRIVE SHAFT SYSTEM****DS****ABS****ABS****ABS (DIAGNOSTICS)****ABS****BRAKE****BR****PARKING BRAKE****PB****POWER ASSISTED SYSTEM
(POWER STEERING)****PS**

ABS (DIAGNOSTICS)

ABS

	Page
1. Basic Diagnostic Procedure	2
2. Check List for Interview	6
3. General Description	9
4. Electrical Components Location.....	12
5. Control Module I/O Signal	14
6. Subaru Select Monitor.....	18
7. Read Diagnostic Trouble Code	20
8. Inspection Mode.....	21
9. Clear Memory Mode.....	22
10. ABS Warning Light Illumination Pattern	23
11. List of Diagnostics Trouble Code	24
12. Diagnostics Chart with Diagnosis Connector	28
13. Diagnostics Chart with Subaru Select Monitor	96
14. General Diagnostics Table.....	186

BASIC DIAGNOSTIC PROCEDURE

ABS (DIAGNOSTICS)

1. Basic Diagnostic Procedure

A: PROCEDURE

1. WITHOUT SUBARU SELECT MONITOR

CAUTION:

Remove foreign matter (dust, water, etc.) from the ABSCM&H/U connector during removal and installation.

NOTE:

- To check harness for broken wires or short circuits, shake it while holding it or the connector.
- When ABS warning light illuminates, read and record trouble code indicated by ABS warning light.

Step	Check	Yes	No
1 CHECK PRE-INSPECTION. 1)Ask the customer when and how the trouble occurred using interview checklist. <Ref. to ABS-6, Check List for Interview.> 2)Before performing diagnosis, inspect unit which might influence the ABS problem. <Ref. to ABS-9, INSPECTION, General Description.>	Is unit that might influence the ABS problem normal?	Go to step 2.	Repair or replace each unit.
2 CHECK INDICATION OF TROUBLE CODE. Calling up trouble code. <Ref. to ABS-20, Read Diagnostic Trouble Code.>	Is trouble code readable?	Go to step 3.	Inspect using diagnostic chart for ABS warning light failure.<Ref. to ABS-28, Diagnostics Chart with Diagnosis Connector.> NOTE: Call up trouble code again after inspecting ABS warning light. <Ref. to ABS-20, Read Diagnostic Trouble Code.>
3 CHECK TROUBLE CODE. NOTE: Record all trouble codes.	Is only the start code issued?	Go to step 4.	Go to step 5.
4 PERFORM THE GENERAL DIAGNOSTICS. 1)Inspect using "General Diagnostics Table". <Ref. to ABS-186, General Diagnostics Table.> 2)Perform the clear memory mode. <Ref. to ABS-22, WITHOUT SUBARU SELECT MONITOR, OPERATION, Clear Memory Mode.> 3)Perform the inspection mode. <Ref. to ABS-21, Inspection Mode.> Calling up the trouble code. <Ref. to ABS-20, Read Diagnostic Trouble Code.>	Is only the start code issued?	Complete the diagnosis.	Go to step 5.

BASIC DIAGNOSTIC PROCEDURE

ABS (DIAGNOSTICS)

Step	Check	Yes	No
<p>5</p> <p>PERFORM THE DIAGNOSIS.</p> <p>1)Inspect using “Diagnostics Chart with Diagnostic Connector”.<Ref. to ABS-28, Diagnostics Chart with Diagnosis Connector.></p> <p>NOTE: For trouble code list, refer to “List of Diagnostics Trouble Code”.<Ref. to ABS-24, WITHOUT SUBARU SELECT MONITOR, LIST, List of Diagnostics Trouble Code.></p> <p>2)Repair trouble cause.</p> <p>3)Perform the clear memory mode. <Ref. to ABS-22, WITHOUT SUBARU SELECT MONITOR, OPERATION, Clear Memory Mode.></p> <p>4)Perform the inspection mode. <Ref. to ABS-21, Inspection Mode.></p> <p>5)Calling up the trouble code. <Ref. to ABS-20, Read Diagnostic Trouble Code.></p>	<p>Is only the start code issued?</p>	<p>Complete the diagnosis.</p>	<p>Inspect using “Diagnostics Chart with Diagnostic Connector”. <Ref. to ABS-28, Diagnostics Chart with Diagnosis Connector.></p>

BASIC DIAGNOSTIC PROCEDURE

ABS (DIAGNOSTICS)

2. WITH SUBARU SELECT MONITOR

CAUTION:

Remove foreign matter (dust, water, etc.) from the ABSCM&H/U connector during removal and installation.

NOTE:

- To check harness for broken wires or short circuits, shake it while holding it or the connector.
- Check list for interview. <Ref. to ABS-26, WITH SUBARU SELECT MONITOR, LIST, List of Diagnostics Trouble Code.>

Step	Check	Yes	No
1 CHECK PRE-INSPECTION. 1)Ask the customer when and how the trouble occurred using interview checklist. <Ref. to ABS-6, Check List for Interview.> 2)Before performing diagnosis, inspect unit which might influence the ABS problem. <Ref. to ABS-9, INSPECTION, General Description.>	Is unit that might influence the ABS problem normal?	Go to step 2.	Repair or replace each unit.
2 CHECK INDICATION OF TROUBLE CODE DISPLAY. 1)Turn ignition switch to OFF. 2)Connect the SUBARU SELECT MONITOR to data link connector. 3)Turn ignition switch to ON and SUBARU SELECT MONITOR to ON. NOTE: If the communication function of the select monitor cannot be executed normally, check the communication circuit. <Ref. to ABS-96, COMMUNICATION FOR INITIALIZING IMPOSSIBLE, Diagnostics Chart with Subaru Select Monitor.> 4)Read diagnostic trouble code. <Ref. to ABS-19, READ CURRENT DATA, OPERATION, Subaru Select Monitor.> 5)Record all trouble codes and frame data.	Is the corresponding trouble encoding?	Go to step 3.	Go to step 4.
3 PERFORM THE GENERAL DIAGNOSTICS. 1)Inspect using "General Diagnostics Table". <Ref. to ABS-186, General Diagnostics Table.> 2)Perform the clear memory mode. <Ref. to ABS-19, CLEAR MEMORY MODE, OPERATION, Subaru Select Monitor.> 3)Perform the inspection mode. <Ref. to ABS-21, Inspection Mode.> 4)Calling up the trouble code. <Ref. to ABS-18, READ DIAGNOSTIC TROUBLE CODE, OPERATION, Subaru Select Monitor.>	Is no trouble code designated and ABS warning light goes out after turning on?	Complete the diagnosis.	Go to step 4.

BASIC DIAGNOSTIC PROCEDURE

ABS (DIAGNOSTICS)

Step	Check	Yes	No
<p>4</p> <p>PERFORM THE DIAGNOSIS.</p> <p>1)Inspect using “Diagnostics Chart with Subaru Select Monitor”.<Ref. to ABS-96, Diagnostics Chart with Subaru Select Monitor.></p> <p>NOTE: For trouble code list, refer to “List of Diagnostics Trouble Code”.<Ref. to ABS-24, WITHOUT SUBARU SELECT MONITOR, LIST, List of Diagnostics Trouble Code.></p> <p>2)Repair trouble cause.</p> <p>3)Perform the clear memory mode. <Ref. to ABS-19, CLEAR MEMORY MODE, OPERATION, Subaru Select Monitor.></p> <p>4)Perform the inspection mode. <Ref. to ABS-21, Inspection Mode.></p> <p>5)Calling up the trouble code. <Ref. to ABS-18, READ DIAGNOSTIC TROUBLE CODE, OPERATION, Subaru Select Monitor.></p>	<p>Is no trouble code designated and does ABS warning light go out after turning on?</p>	<p>Complete the diagnosis.</p>	<p>Inspect using “Diagnostics Chart with Subaru Select Monitor”. <Ref. to ABS-96, Diagnostics Chart with Subaru Select Monitor.></p>

CHECK LIST FOR INTERVIEW

ABS (DIAGNOSTICS)

2. Check List for Interview

A: CHECK

Check the following items about the vehicle's state.

1. STATE OF ABS WARNING LIGHT

ABS warning light comes on.	<input type="checkbox"/> Always <input type="checkbox"/> Sometimes <input type="checkbox"/> Only once <input type="checkbox"/> Does not come on • When / how long does it come on?:		
Ignition key position	<input type="checkbox"/> LOCK <input type="checkbox"/> ACC <input type="checkbox"/> ON (before starting engine) <input type="checkbox"/> START <input type="checkbox"/> On after starting (Engine is running) <input type="checkbox"/> On after starting (Engine is stop)		
Timing	<input type="checkbox"/> Immediately after ignition is ON. <input type="checkbox"/> Immediately after ignition starts.		
	<input type="checkbox"/> When advancing	km/h to	km/h
		MPH to	MPH
	<input type="checkbox"/> While traveling at a constant speed	km/h	MPH
	<input type="checkbox"/> When decelerating	km/h to	km/h
		MPH to	MPH
	<input type="checkbox"/> When turning to right	Steering angle :	deg
		Steering time :	sec
	<input type="checkbox"/> When turning to left	Steering angle :	deg
		Steering time :	sec
<input type="checkbox"/> When moving other electrical parts • Parts name : • Operating condition :			

2. SYMPTOMS

ABS operating condition	<input type="checkbox"/> Performs no work.		
	<input type="checkbox"/> Operates only when abruptly applying brakes.	Vehicle speed :	km/h
			MPH
	• How to step on brake pedal :		
	a) Operating time :		sec
	b) Operating noise : <input type="checkbox"/> Produce / <input type="checkbox"/> Does not produce		
	• What kind of noise?	<input type="checkbox"/> Knock <input type="checkbox"/> Gong gong <input type="checkbox"/> Bong <input type="checkbox"/> Buzz <input type="checkbox"/> Gong gong buzz <input type="checkbox"/> Others :	
	c) Reaction force of brake pedal		
		<input type="checkbox"/> Stick <input type="checkbox"/> Press down once with a clunk <input type="checkbox"/> Press and released <input type="checkbox"/> Others :	

CHECK LIST FOR INTERVIEW

ABS (DIAGNOSTICS)

Behavior of vehicle	a) Directional stability cannot be obtained or steering arm refuses to work when applying brakes : <input type="checkbox"/> Yes / <input type="checkbox"/> No	
	• When :	<input type="checkbox"/> Vehicle turns to right <input type="checkbox"/> Vehicle turns to left <input type="checkbox"/> Spins <input type="checkbox"/> Others :
	b) Directional stability cannot be obtained or steering arm refuses to work when accelerating : <input type="checkbox"/> Yes / <input type="checkbox"/> No	
	• When :	<input type="checkbox"/> Vehicle turns to right <input type="checkbox"/> Vehicle turns to left <input type="checkbox"/> Spins <input type="checkbox"/> Others :
	c) Brakes are out of order : <input type="checkbox"/> Yes / <input type="checkbox"/> No	
	• What :	<input type="checkbox"/> Braking distance is long <input type="checkbox"/> Brakes lock or drag <input type="checkbox"/> Pedal stroke is long <input type="checkbox"/> Pedal sticks <input type="checkbox"/> Others :
	d) Poor acceleration : <input type="checkbox"/> Yes / <input type="checkbox"/> No	
	• What :	<input type="checkbox"/> Fails to accelerate <input type="checkbox"/> Engine stalls <input type="checkbox"/> Others :
	e) Occurrence of vibration : <input type="checkbox"/> Yes / <input type="checkbox"/> No	
	• Where	
• What kind :		
f) Occurrence of abnormal noise : <input type="checkbox"/> Yes / <input type="checkbox"/> No		
• Where		
• What kind :		
g) Occurrence of other phenomena : <input type="checkbox"/> Yes / <input type="checkbox"/> No		
• What kind :		

3. CONDITIONS UNDER WHICH TROUBLE OCCURS

Environment	a) Weather	<input type="checkbox"/> Fine <input type="checkbox"/> Cloudy <input type="checkbox"/> Rainy <input type="checkbox"/> Snowy <input type="checkbox"/> Various/Others :
	b) Ambient temperature	°F (°C)
	c) Road	<input type="checkbox"/> Urban area <input type="checkbox"/> Suburbs <input type="checkbox"/> Highway <input type="checkbox"/> General road <input type="checkbox"/> Ascending slope <input type="checkbox"/> Descending slope <input type="checkbox"/> Paved road <input type="checkbox"/> Gravel road <input type="checkbox"/> Muddy road <input type="checkbox"/> Sandy place <input type="checkbox"/> Others :
	d) Road surface	<input type="checkbox"/> Dry <input type="checkbox"/> Wet <input type="checkbox"/> New-fallen snow <input type="checkbox"/> Compressed snow <input type="checkbox"/> Frozen slope <input type="checkbox"/> Others :

CHECK LIST FOR INTERVIEW

ABS (DIAGNOSTICS)

Condition	a) Brakes	Deceleration : _____ g		
		<input type="checkbox"/> Continuous / <input type="checkbox"/> Intermittent		
	b) Accelerator	Acceleration : _____ g		
		<input type="checkbox"/> Continuous / <input type="checkbox"/> Intermittent		
	c) Vehicle speed	km/h	MPH	
		<input type="checkbox"/> Advancing <input type="checkbox"/> Accelerating <input type="checkbox"/> Reducing speed <input type="checkbox"/> Low speed <input type="checkbox"/> Turning <input type="checkbox"/> Others : _____		
	d) Tire inflation pressure	Front RH tire :	_____ kPa	
		Front LH tire :	_____ kPa	
		Rear RH tire :	_____ kPa	
		Rear LH tire :	_____ kPa	
	e) Degree of wear	Front RH tire :	_____	
		Front LH tire :	_____	
		Rear RH tire :	_____	
		Rear LH tire :	_____	
	f) Genuine parts are used. : <input type="checkbox"/> Yes / <input type="checkbox"/> No			
	g) Chain is passed around tires. : <input type="checkbox"/> Yes / <input type="checkbox"/> No			
	h) T tire is used. : <input type="checkbox"/> Yes / <input type="checkbox"/> No			
i) Condition of suspension alignment :				
j) Loading state :				
k) Repair parts are used. : <input type="checkbox"/> Yes / <input type="checkbox"/> No				
• What :				
l) Others :				

3. General Description

A: CAUTION

1. SUPPLEMENTAL RESTRAINT SYSTEM "AIRBAG"

Airbag system wiring harness is routed near the ABS sensor, ABS control module and hydraulic control unit.

CAUTION:

- All Airbag system wiring harness and connectors are colored yellow. Do not use electrical test equipment on these circuit.
- Be careful not to damage Airbag system wiring harness when servicing the ABS sensor, ABS control module and hydraulic control unit.

B: INSPECTION

Before performing diagnostics, check the following items which might affect ABS problems:

1. BATTERY

Measure battery voltage and specific gravity of electrolyte.

Standard voltage: 12 V, or more

Specific gravity: Above 1.260

2. BRAKE FLUID

- 1) Check brake fluid level.
- 2) Check brake fluid leakage.

3. HYDRAULIC UNIT

Check the hydraulic unit.

- With brake tester <Ref. to ABS-9, CHECKING THE HYDRAULIC UNIT ABS OPERATION WITH BRAKE TESTER, INSPECTION, ABS Control Module and Hydraulic Control Unit (ABSCM&H/U).>
- Without brake tester <Ref. to ABS-8, CHECKING THE HYDRAULIC UNIT ABS OPERATION BY PRESSURE GAUGE, INSPECTION, ABS Control Module and Hydraulic Control Unit (ABSCM&H/U).>

4. BRAKE DRAG

Check brake drag.

5. BRAKE PAD AND ROTOR

Check brake pad and rotor.

- Front <Ref. to BR-24, INSPECTION, Front Brake Pad.> and <Ref. to BR-27, INSPECTION, Front Disc Rotor.>
- Rear <Ref. to BR-35, INSPECTION, Rear Brake Pad.> and <Ref. to BR-38, INSPECTION, Rear Disc Rotor.> or <Ref. to BR-45, INSPECTION, Rear Drum Brake Shoe.> and <Ref. to BR-47, INSPECTION, Rear Drum Brake Drum.>

6. TIRE



Check tire specifications, tire wear and air pressure. <Ref. to WT-2, SPECIFICATIONS, General Description.>

GENERAL DESCRIPTION

ABS (DIAGNOSTICS)

C: PREPARATION TOOL

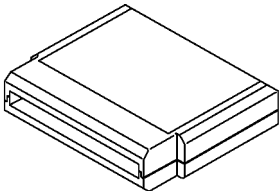
1. SPECIAL TOOLS

ILLUSTRATION	TOOL NUMBER	DESCRIPTION	REMARKS
 B2M3876	24082AA150	CARTRIDGE	Troubleshooting for electrical systems.
 B2M3877	22771AA030	SELECT MONITOR KIT	Troubleshooting for electrical systems. <ul style="list-style-type: none"> • English: 22771AA030 (Without printer) • German: 22771AA070 (Without printer) • French: 22771AA080 (Without printer) • Spanish: 22771AA090 (Without printer)

2. GENERAL PURPOSE TOOLS

TOOL NAME	REMARKS
Circuit tester	Used for measuring resistance, voltage and ampere.
Oscilloscope	Used for measuring sensor.

ELECTRICAL COMPONENTS LOCATION

ABS (DIAGNOSTICS)

4. Electrical Components Location

A: LOCATION

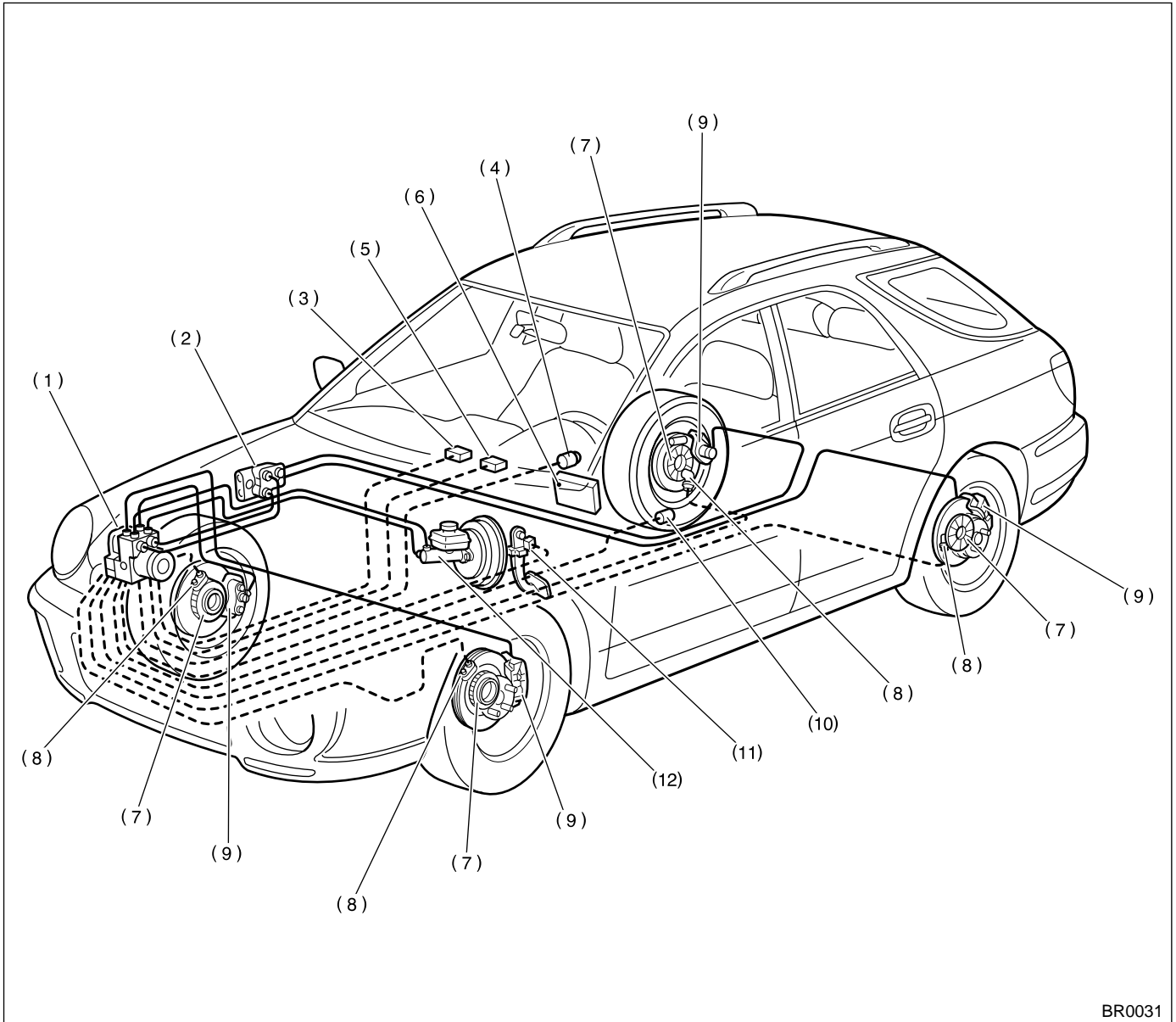

BR0031

- | | | |
|---|---|------------------------|
| (1) ABS control module and hydraulic control unit (ABSCM&H/U) | (5) Data link connector (for Subaru select monitor) | (8) ABS sensor |
| (2) Proportioning valve | (6) Transmission control module (only AT vehicle) | (9) Wheel cylinder |
| (3) Diagnosis connector | (7) Tone wheel | (10) G sensor |
| (4) ABS warning light | | (11) Stop light switch |
| | | (12) Master cylinder |

ELECTRICAL COMPONENTS LOCATION

ABS (DIAGNOSTICS)

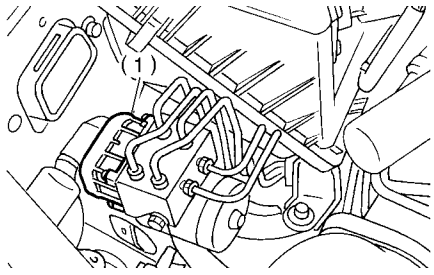
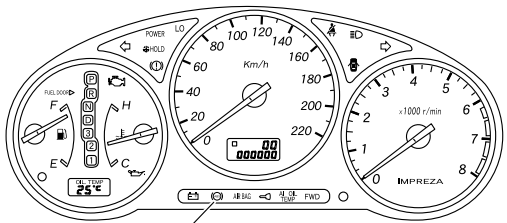
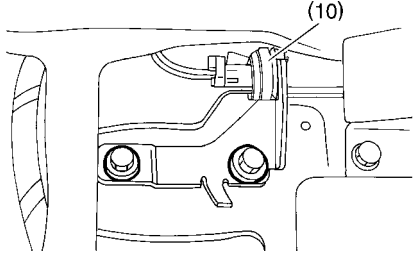
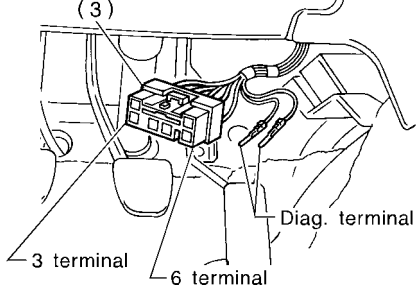
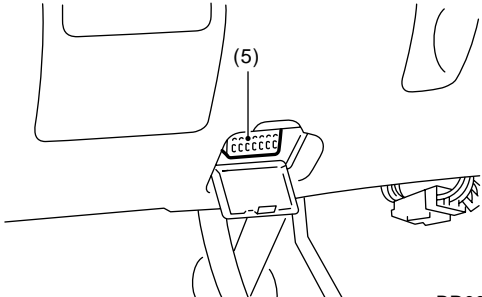
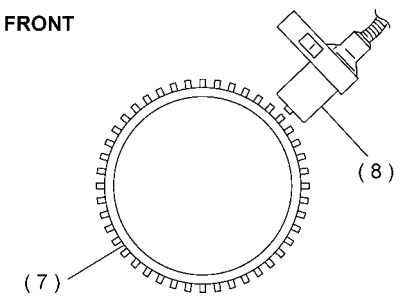
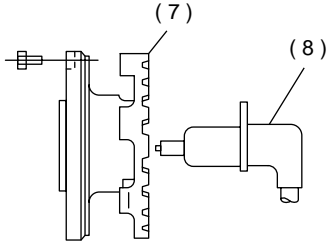
 <p>B4M1226B</p>	 <p>BR0032</p>
 <p>BR0056</p>	 <p>B4M0231E</p>
 <p>BR0033</p>	<p>FRONT</p>  <p>BR0057</p>
<p>REAR</p>  <p>BR0058</p>	<p style="text-align: center;">SUBARU.</p>

5. Control Module I/O Signal

A: ELECTRICAL SPECIFICATION

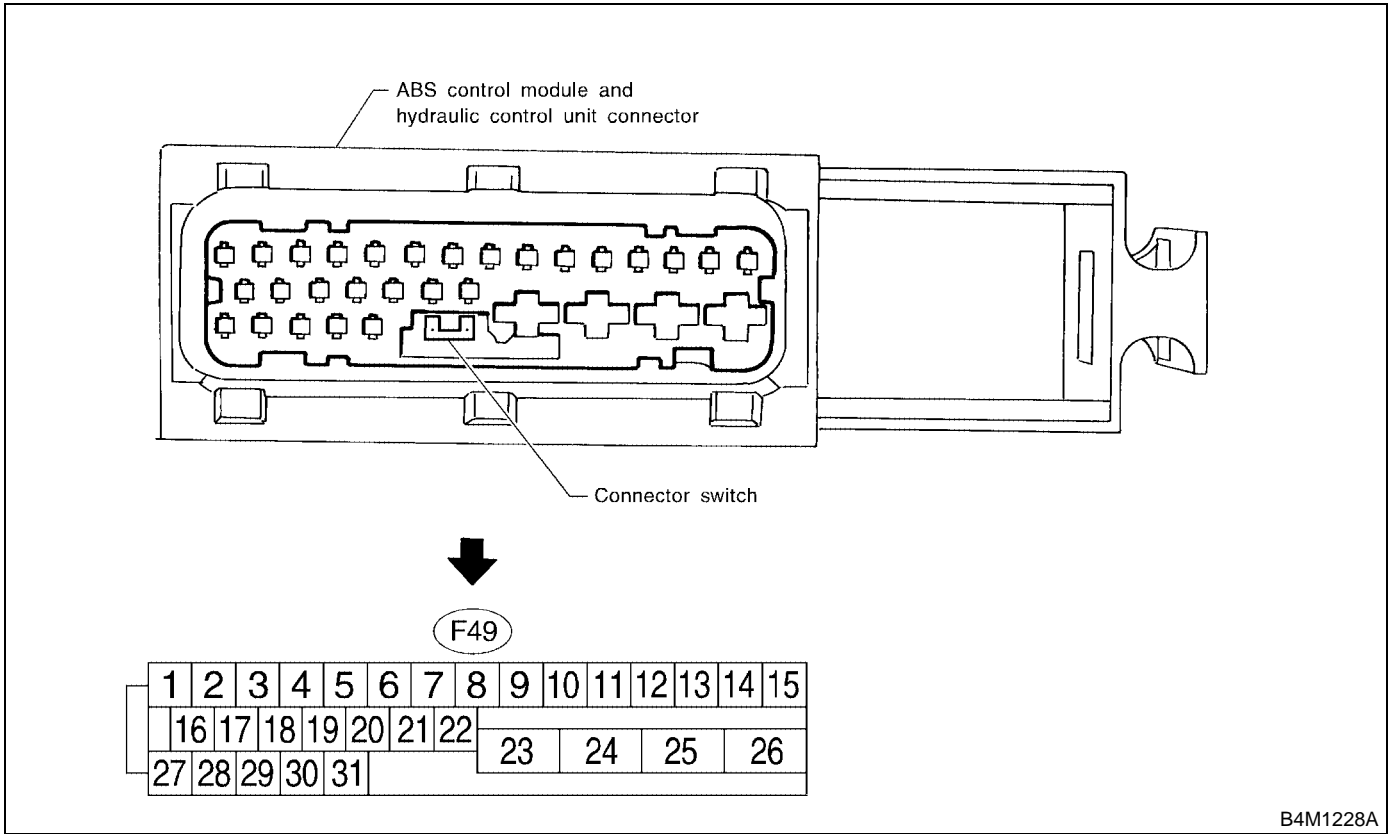

NOTE:

- The terminal numbers in the ABS control module and hydraulic control unit connector are as shown in the figure.
- When the connector is removed from the ABSCM&H/U, the connector switch closes the circuit between terminal No. 22 and No. 23. The ABS warning light illuminates.

CONTROL MODULE I/O SIGNAL

ABS (DIAGNOSTICS)

Contents		Terminal No. (+)-(-)	Input/Output signal
			Measured value and measuring conditions
ABS sensor*2 (Wheel speed sensor)	Front left wheel	9—10	0.12 — 1 V (When it is 20 Hz.)
	Front right wheel	11—12	
	Rear left wheel	7—8	
	Rear right wheel	14—15	
Valve relay power supply		24—23	10 — 15 V
Motor relay power supply		25—23	10 — 15 V
G sensor*2 (AWD model only)	power supply	30—28	4.75 — 5.25 V
	ground	28	—
	output	6—28	2.3±0.2 V when vehicle is in horizontal position.
Stop light switch*1		2—23	Less than 1.5 V when the stop light is OFF and, 10 — 15 V when the stop light is ON.
ABS warning light*2		22—23	Less than 1.5 V during 1.5 seconds when ignition switch is ON, and 10 — 15 V after 1.5 seconds.
AT ABS signal*2 (AT model only)		31—23	Less than 1.5 V when the ABS control still operates and more than 5.5 V when ABS does not operate.
ABS operation signal monitor*2		3—23	Less than 1.5 V when the ABS control still operates and more than 5.5 V when ABS does not operate.
Select monitor*2	Data is received.	20—23	Less than 1.5 V when no data is received.
	Data is sent.	5—23	4.75 — 5.25 V when no data is sent.
ABS diagnosis connector*2	Terminal No. 3	29—23	10 — 15 V when ignition switch is ON.
	Terminal No. 6	4—23	10 — 15 V when ignition switch is ON.
Power supply*1		1—23	10 — 15 V when ignition switch is ON.
Grounding line		23	—
Grounding line		26	—

*1: Measure the I/O signal voltage after removing the connector from the ABSCM&H/U terminal.

*2: Measure the I/O signal voltage at connector (B200) or (F74).

CONTROL MODULE I/O SIGNAL

ABS (DIAGNOSTICS)

B: SCHEMATIC

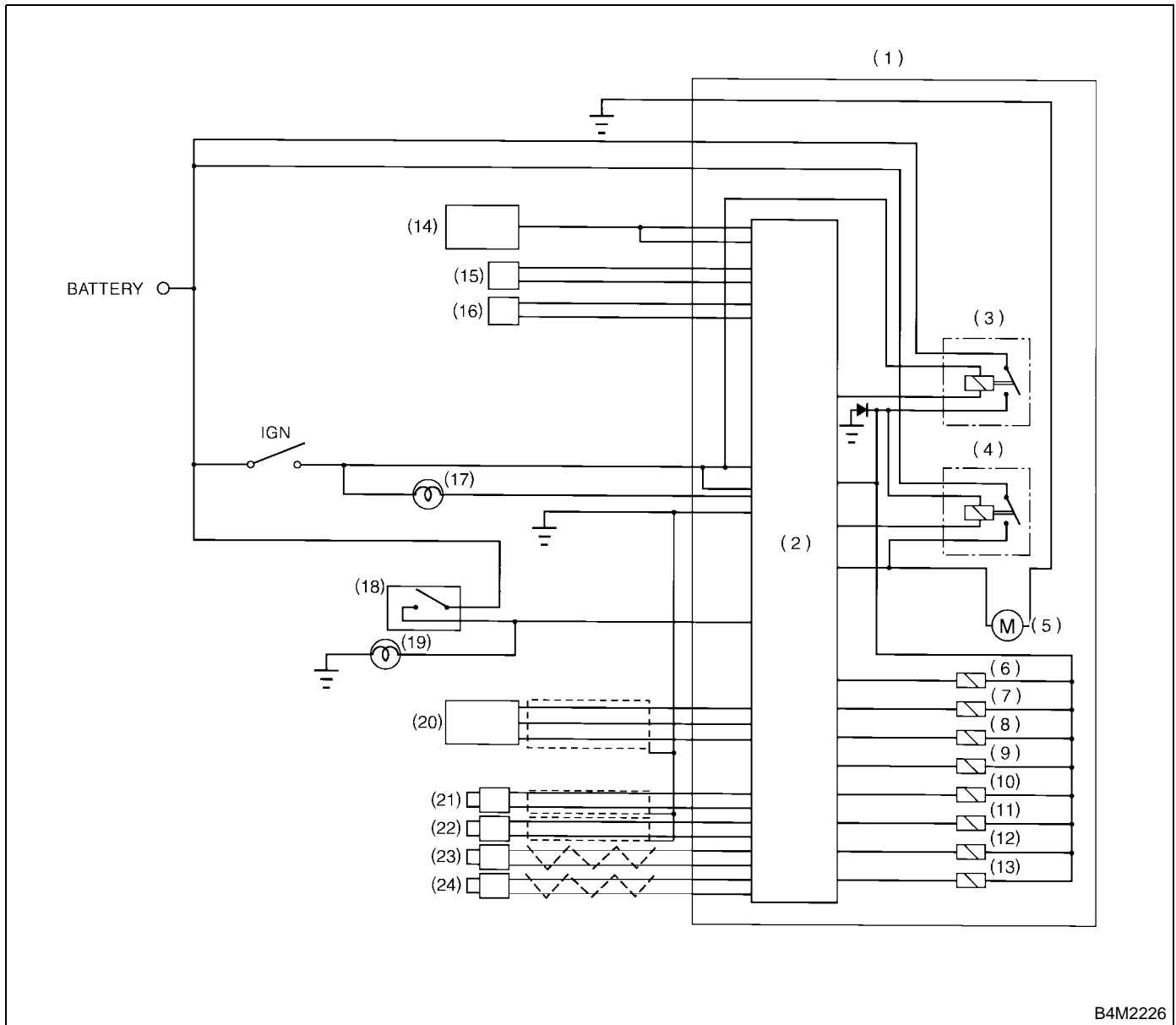

- | | | |
|---|--|-----------------------------|
| (1) ABS control module and hydraulic control unit (ABSCM&H/U) | (9) Front right outlet solenoid valve | (17) ABS warning light |
| (2) ABS control module area | (10) Rear left inlet solenoid valve | (18) Stop light switch |
| (3) Valve relay | (11) Rear left outlet solenoid valve | (19) Stop light |
| (4) Motor relay | (12) Rear right inlet solenoid valve | (20) G sensor |
| (5) Motor | (13) Rear right outlet solenoid valve | (21) Front left ABS sensor |
| (6) Front left inlet solenoid valve | (14) Transmission control module (only AT model) | (22) Front right ABS sensor |
| (7) Front left outlet solenoid valve | (15) Diagnosis connector | (23) Rear left ABS sensor |
| (8) Front right inlet solenoid valve | (16) Data link connector | (24) Rear right ABS sensor |

C: WAVEFORM

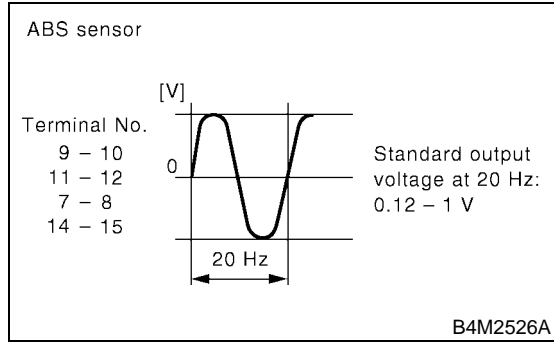

6. Subaru Select Monitor

A: OPERATION

1. READ DIAGNOSTIC TROUBLE CODE

1) Prepare Subaru Select Monitor kit.

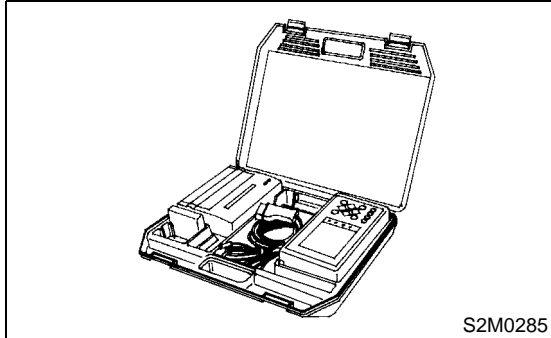

2) Connect diagnosis cable to Subaru Select Monitor.

3) Insert cartridge into Subaru Select Monitor.
<Ref. to ABS-10, SPECIAL TOOLS, PREPARATION TOOL, General Description.>

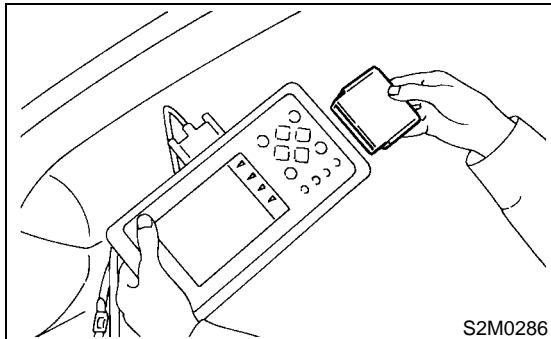

4) Connect Subaru Select Monitor to data link connector.

(1) Data link connector located in the lower portion of the instrument panel (on the driver's side).

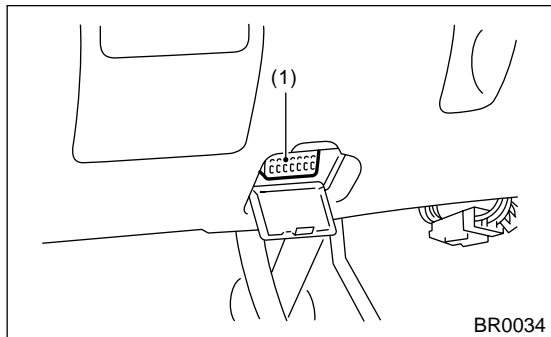

(1) Data link connector

(2) Connect diagnosis cable to data link connector.

5) Turn ignition switch to ON (engine OFF) and Subaru Select Monitor switch to ON.

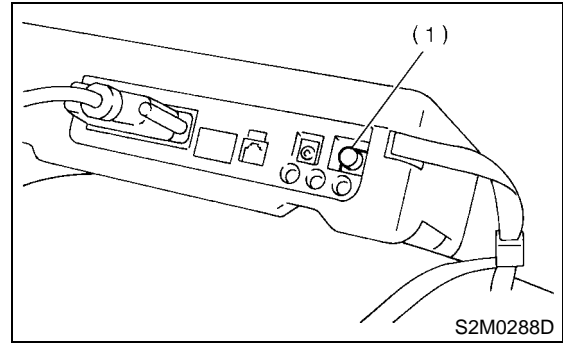

(1) Power switch

6) On the «Main Menu» display screen, select the {Each System Check} and press the [YES] key.

7) On the «System Selection Menu» display screen, select the {Brake Control System} and press the [YES] key.

8) Press the [YES] key after displayed the information of engine type.

9) On the «ABS Diagnosis» display screen, select the {Diagnostic Code(s) Display} and press the [YES] key.

10) On the «Diagnostic Code(s) Display» display screen, select the {Current Diagnostic Code(s)} or {History Diagnostic Code(s)} and press the [YES] key.

NOTE:

- For detailed operation procedure, refer to the SUBARU SELECT MONITOR OPERATION MANUAL.

- For detailed concerning diagnostic trouble codes, refer to the LIST OF DIAGNOSTICS TROUBLE CODE. <Ref. to ABS-24, List of Diagnostics Trouble Code.>

2. READ CURRENT DATA

- 1) On the «Main Menu» display screen, select the {Each System Check} and press the «YES» key.
 - 2) On the «System Selection Menu» display screen, select the {Brake Control System} and press the «YES» key.
 - 3) Press the «YES» key after displayed the information of ABS type.
 - 4) On the «Brake Control Diagnosis» display screen, select the {Current Data Display & Save} and press the «YES» key.
 - 5) On the «Data Display Menu» display screen, select the {Data Display} and press the «YES» key.
 - 6) Using the scroll key, move the display screen up or down until the desired data is shown.
- A list of the support data is shown in the following table.

Display screen	Contents to be monitored	Unit of measure
FR Wheel Speed	Wheel speed detected by the Front Right ABS sensor is displayed	km/h or MPH
FL Wheel Speed	Wheel speed detected by the Front Left ABS sensor is displayed	km/h or MPH
RR Wheel Speed	Wheel speed detected by the Rear Right ABS sensor is displayed	km/h or MPH
RL Wheel Speed	Wheel speed detected by the Rear Left ABS sensor is displayed	km/h or MPH
Stop Light Switch	Stop light switch signal	ON or OFF
Stop Light Switch	Stop light switch monitor voltage is displayed.	V
G sensor output Signal	Refers to vehicle acceleration detecting by the analog G sensor. It appears on the select monitor display in volts.	V
Valve Relay Signal	Valve Relay Signal	ON or OFF
Motor Relay Signal	Motor Relay Signal	ON or OFF
ABS Signal to TCM	ABS operation signal from ABS control module to TCM	ON or OFF
ABS Warning Lamp	ON operation of the ABS warning light is displayed.	ON or OFF
Motor Relay Monitor	Operating condition of the motor relay is displayed.	High or Low
Valve Relay Monitor	Operating condition of the valve relay is displayed.	ON or OFF
CCM Signal	ABS operation signal from ABS control module to TCM	ON or OFF

NOTE:

For detailed operation procedure, refer to the SUBARU SELECT MONITOR OPERATION MANUAL.

3. CLEAR MEMORY MODE

- 1) On the «Main Menu» display screen, select the {2. Each System Check} and press the «YES» key.
- 2) On the «System Select Menu» display screen, select {Brake System} and press the «YES» key.
- 3) Press the «YES» key after displayed the information of engine type.
- 4) On the «Brake Control Diagnosis» display screen, select the {Clear Memory} and press the «YES» key.
- 5) When the “Done” and “turn ignition switch OFF” are shown on the display screen, turn the Subaru Select Monitor and ignition switch to OFF.

NOTE:

For detailed operation procedure, refer to the SUBARU SELECT MONITOR OPERATION MANUAL.

READ DIAGNOSTIC TROUBLE CODE

ABS (DIAGNOSTICS)

7. Read Diagnostic Trouble Code

A: OPERATION

1. WITHOUT SUBARU SELECT MONITOR

1) Take out diagnosis connector from side of driver's seat heater unit.

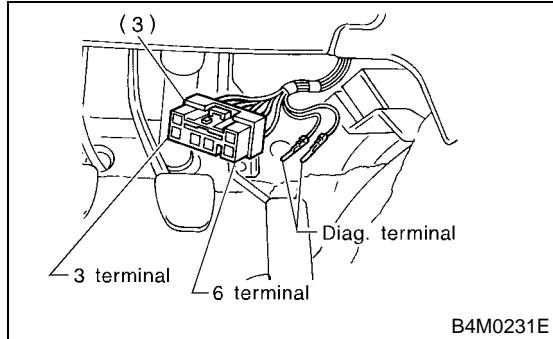

- 2) Turn ignition switch OFF.
- 3) Connect diagnosis connector terminal 6 to diagnosis terminal.
- 4) Turn ignition switch ON.
- 5) ABS warning light is set in the diagnostic mode and blinks to identify trouble code.
- 6) After the start code (11) is shown, the trouble codes will be shown in order of the last information first.

These repeat for a maximum of 3 minutes.

NOTE:

- When there are no trouble codes in memory, only the start code (11) is shown.
- When on-board diagnosis of the ABS control module detects a problem, the information (up to a maximum of three) will be stored in the EEPROM as a trouble code. When there are more than three, the most recent three will be stored. (Stored codes will stay in memory until they are cleared.)

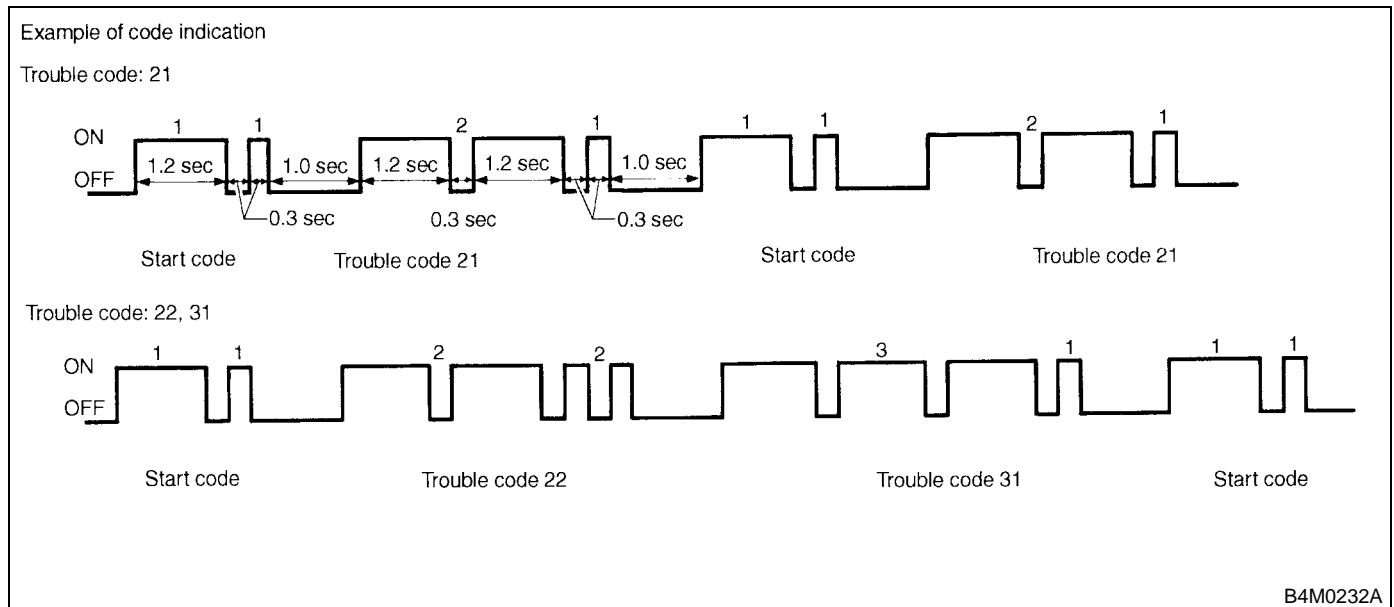

2. WITH SUBARU SELECT MONITOR

Refer to SUBARU SELECT MONITOR for information about how to obtain and understand trouble codes.
<Ref. to ABS-18, Subaru Select Monitor.>

8. Inspection Mode

A: OPERATION

Reproduce the condition under which the problem has occurred as much as possible.

Drive the vehicle at a speed more than 40 km/h (25 MPH) for at least one minute.

CLEAR MEMORY MODE

ABS (DIAGNOSTICS)

9. Clear Memory Mode

A: OPERATION

1. WITHOUT SUBARU SELECT MONITOR

1) After calling up a trouble code, disconnect diagnosis connector terminal 6 from diagnosis terminal.

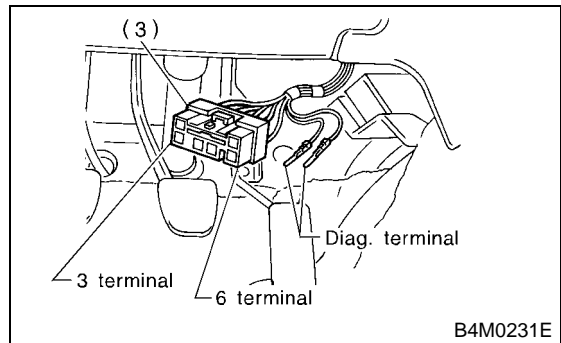

2) Repeat 3 times within approx. 12 seconds; connecting and disconnecting terminal 6 and diagnosis terminal for at least 0.2 seconds each time.

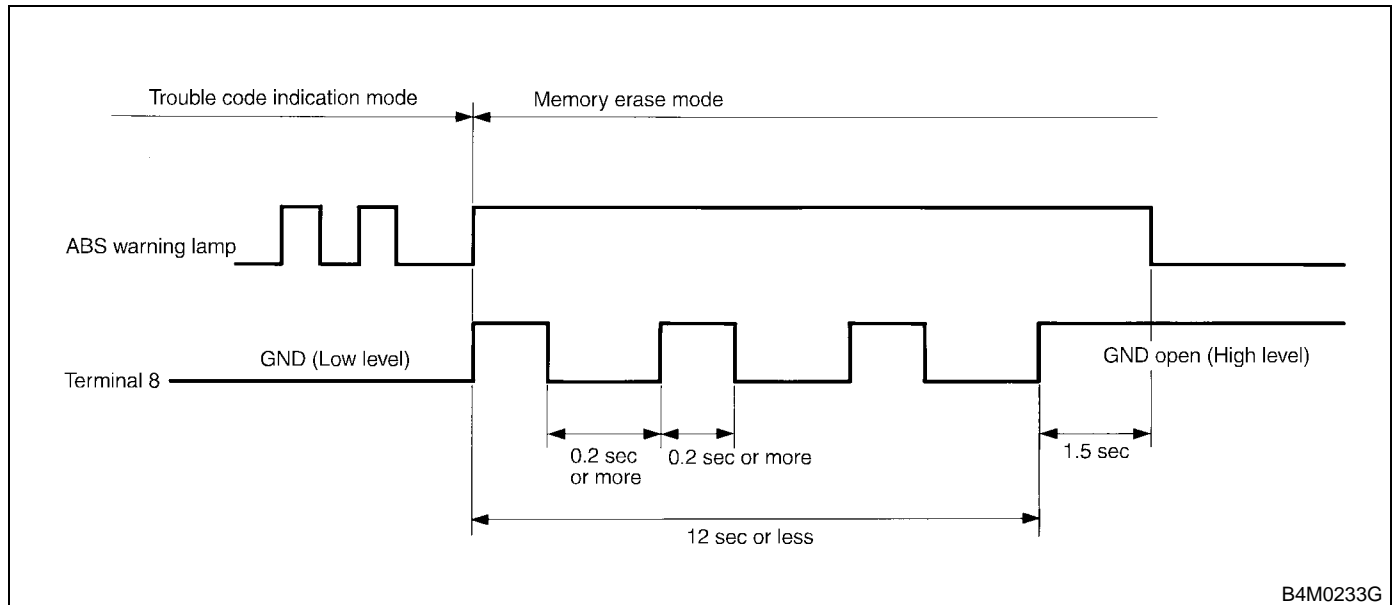

NOTE:

After diagnostics is completed, make sure to clear memory. Make sure only start code (11) is shown after memory is cleared.

2. WITH SUBARU SELECT MONITOR

Refer to SUBARU SELECT MONITOR for information about how to clear trouble codes. <Ref. to ABS-18, Subaru Select Monitor.>

10.ABS Warning Light Illumination Pattern

A: INSPECTION

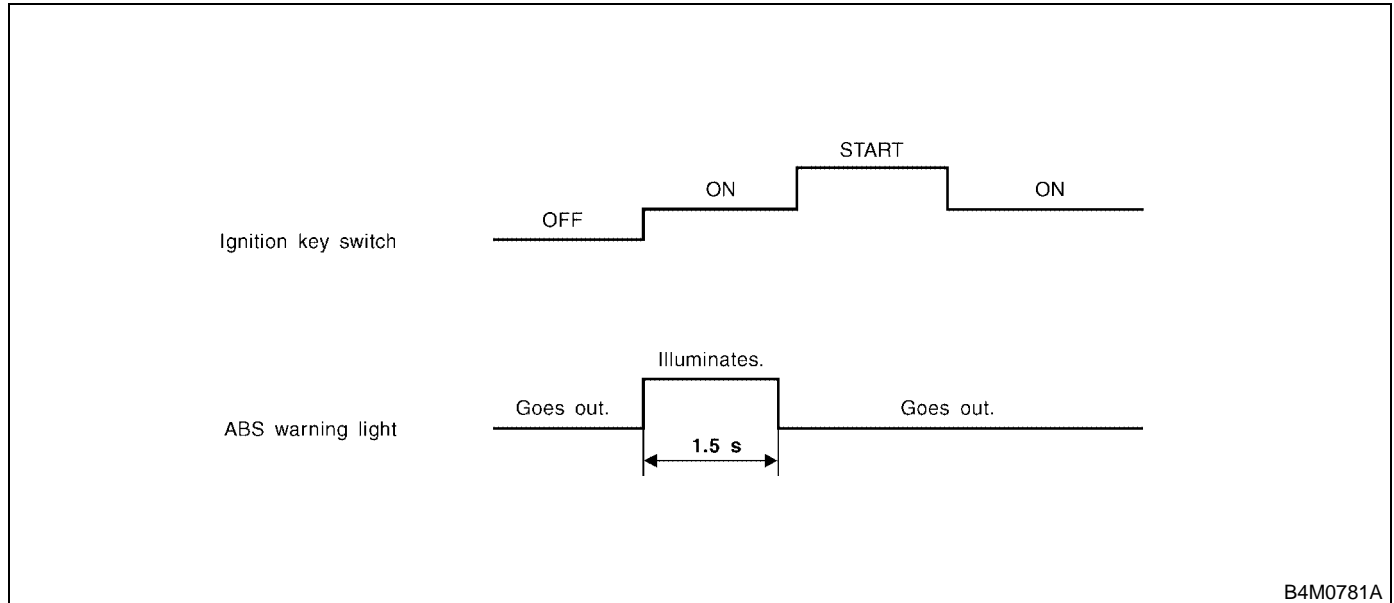

1) When the ABS warning light does not illuminate in accordance with this illumination pattern, there must be an electrical malfunction.

2) When the ABS warning light remains constantly OFF, repair the ABS warning light circuit or diagnosis circuit. <Ref. to ABS-28, Diagnostics Chart with Diagnosis Connector.>

NOTE:

Even though the ABS warning light does not go out 1.5 seconds after it illuminates, the ABS system operates normally when the warning light goes out while driving at approximately 12 km/h (7 MPH). However, the Anti-lock brakes do not work while the ABS warning light is illuminated.

LIST OF DIAGNOSTICS TROUBLE CODE

ABS (DIAGNOSTICS)

11. List of Diagnostics Trouble Code

A: LIST

1. WITHOUT SUBARU SELECT MONITOR

Trouble code	Contents of diagnosis		Index No.
11	Start code • Trouble code is shown after start code. • Only start code is shown in normal condition.		—
21	Abnormal ABS sensor (Open circuit or input voltage too high)	Front right ABS sensor	<Ref. to ABS-39, TROUBLE CODE 21 — ABNORMAL ABS SENSOR (OPEN CIRCUIT OR INPUT VOLTAGE TOO HIGH) (FRONT RH) —, Diagnostics Chart with Diagnosis Connector.>
23		Front left ABS sensor	<Ref. to ABS-39, TROUBLE CODE 23 — ABNORMAL ABS SENSOR (OPEN CIRCUIT OR INPUT VOLTAGE TOO HIGH) (FRONT LH) —, Diagnostics Chart with Diagnosis Connector.>
25		Rear right ABS sensor	<Ref. to ABS-39, TROUBLE CODE 25 — ABNORMAL ABS SENSOR (OPEN CIRCUIT OR INPUT VOLTAGE TOO HIGH) (REAR RH) —, Diagnostics Chart with Diagnosis Connector.>
27		Rear left ABS sensor	<Ref. to ABS-40, TROUBLE CODE 27 — ABNORMAL ABS SENSOR (OPEN CIRCUIT OR INPUT VOLTAGE TOO HIGH) (REAR LH) —, Diagnostics Chart with Diagnosis Connector.>
22	Abnormal ABS sensor (Abnormal ABS sensor signal)	Front right ABS sensor	<Ref. to ABS-46, TROUBLE CODE 22 — ABNORMAL ABS SENSOR (FRONT RH) —, Diagnostics Chart with Diagnosis Connector.>
24		Front left ABS sensor	<Ref. to ABS-46, TROUBLE CODE 24 — ABNORMAL ABS SENSOR (FRONT LH) —, Diagnostics Chart with Diagnosis Connector.>
26		Rear right ABS sensor	<Ref. to ABS-46, TROUBLE CODE 26 — ABNORMAL ABS SENSOR (REAR RH) —, Diagnostics Chart with Diagnosis Connector.>
28		Rear left ABS sensor	<Ref. to ABS-48, TROUBLE CODE 28 — ABNORMAL ABS SENSOR (REAR LH) —, Diagnostics Chart with Diagnosis Connector.>
29		Any one of four	<Ref. to ABS-54, TROUBLE CODE 29 — ABNORMAL ABS SENSOR SIGNAL (ANY ONE OF FOUR) —, Diagnostics Chart with Diagnosis Connector.>

LIST OF DIAGNOSTICS TROUBLE CODE

ABS (DIAGNOSTICS)

Trouble code	Contents of diagnosis		Index No.
31	Abnormal solenoid valve circuit(s) in ABS control module and hydraulic unit	Front right inlet valve	<Ref. to ABS-58, TROUBLE CODE 31 — ABNORMAL INLET SOLENOID VALVE CIRCUIT(S) IN ABSCM&H/U (FRONT RH) —, Diagnostics Chart with Diagnosis Connector.>
32		Front right outlet valve	<Ref. to ABS-63, TROUBLE CODE 32 — ABNORMAL OUTLET SOLENOID VALVE CIRCUIT(S) IN ABSCM&H/U (FRONT RH) —, Diagnostics Chart with Diagnosis Connector.>
33		Front left inlet valve	<Ref. to ABS-58, TROUBLE CODE 33 — ABNORMAL INLET SOLENOID VALVE CIRCUIT(S) IN ABSCM&H/U (FRONT LH) —, Diagnostics Chart with Diagnosis Connector.>
34		Front left outlet valve	<Ref. to ABS-63, TROUBLE CODE 34 — ABNORMAL OUTLET SOLENOID VALVE CIRCUIT(S) IN ABSCM&H/U (FRONT LH) —, Diagnostics Chart with Diagnosis Connector.>
35		Rear right inlet valve	<Ref. to ABS-58, TROUBLE CODE 35 — ABNORMAL INLET SOLENOID VALVE CIRCUIT(S) IN ABSCM&H/U (REAR RH) —, Diagnostics Chart with Diagnosis Connector.>
36		Rear right outlet valve	<Ref. to ABS-63, TROUBLE CODE 36 — ABNORMAL OUTLET SOLENOID VALVE CIRCUIT(S) IN ABSCM&H/U (REAR RH) —, Diagnostics Chart with Diagnosis Connector.>
37		Rear left inlet valve	<Ref. to ABS-59, TROUBLE CODE 37 — ABNORMAL INLET SOLENOID VALVE CIRCUIT(S) IN ABSCM&H/U (REAR LH) —, Diagnostics Chart with Diagnosis Connector.>
38		Rear left outlet valve	<Ref. to ABS-65, TROUBLE CODE 38 — ABNORMAL OUTLET SOLENOID VALVE CIRCUIT(S) IN ABSCM&H/U (REAR LH) —, Diagnostics Chart with Diagnosis Connector.>
41	Abnormal ABS control module		<Ref. to ABS-70, TROUBLE CODE 41 — ABNORMAL ABS CONTROL MODULE —, Diagnostics Chart with Diagnosis Connector.>
42	Source voltage is abnormal.		<Ref. to ABS-72, TROUBLE CODE 42 — SOURCE VOLTAGE IS ABNORMAL. —, Diagnostics Chart with Diagnosis Connector.>
44	A combination of AT control abnormal		<Ref. to ABS-76, TROUBLE CODE 44 — A COMBINATION OF AT CONTROL ABNORMAL —, Diagnostics Chart with Diagnosis Connector.>
51	Abnormal valve relay		<Ref. to ABS-79, TROUBLE CODE 51 — ABNORMAL VALVE RELAY —, Diagnostics Chart with Diagnosis Connector.>
52	Abnormal motor and/or motor relay		<Ref. to ABS-83, TROUBLE CODE 52 — ABNORMAL MOTOR AND/OR MOTOR RELAY —, Diagnostics Chart with Diagnosis Connector.>
54	Abnormal stop light switch		<Ref. to ABS-88, TROUBLE CODE 54 — ABNORMAL STOP LIGHT SWITCH —, Diagnostics Chart with Diagnosis Connector.>
56	Abnormal G sensor output voltage		<Ref. to ABS-90, TROUBLE CODE 56 — ABNORMAL G SENSOR OUTPUT VOLTAGE —, Diagnostics Chart with Diagnosis Connector.>

LIST OF DIAGNOSTICS TROUBLE CODE

ABS (DIAGNOSTICS)

2. WITH SUBARU SELECT MONITOR

Code	Display screen	Contents of diagnosis	Index No.
—	Communication for initializing impossible	Select monitor communication failure	<Ref. to ABS-96, COMMUNICATION FOR INITIALIZING IMPOSSIBLE, Diagnostics Chart with Subaru Select Monitor.>
—	No trouble code	Although no trouble code appears on the select monitor display, the ABS warning light remains on.	<Ref. to ABS-100, NO TROUBLE CODE, Diagnostics Chart with Subaru Select Monitor.>
21	Open or short circuit in front right ABS sensor circuit	Open or short circuit in front right ABS sensor circuit	<Ref. to ABS-104, TROUBLE CODE 21 — OPEN OR SHORT CIRCUIT IN FRONT RIGHT ABS SENSOR CIRCUIT —, Diagnostics Chart with Subaru Select Monitor.>
22	Front right ABS sensor abnormal signal	Front right ABS sensor abnormal signal	<Ref. to ABS-112, TROUBLE CODE 22 — FRONT RIGHT ABNORMAL ABS SENSOR SIGNAL —, Diagnostics Chart with Subaru Select Monitor.>
23	Open or short circuit in front left ABS sensor circuit	Open or short circuit in front left ABS sensor circuit	<Ref. to ABS-104, TROUBLE CODE 23 — OPEN OR SHORT CIRCUIT IN FRONT LEFT ABS SENSOR CIRCUIT —, Diagnostics Chart with Subaru Select Monitor.>
24	Front left ABS sensor abnormal signal	Front left ABS sensor abnormal signal	<Ref. to ABS-112, TROUBLE CODE 24 — FRONT LEFT ABNORMAL ABS SENSOR SIGNAL —, Diagnostics Chart with Subaru Select Monitor.>
25	Open or short circuit in rear right ABS sensor circuit	Open or short circuit in rear right ABS sensor circuit	<Ref. to ABS-104, TROUBLE CODE 25 — OPEN OR SHORT CIRCUIT IN REAR RIGHT ABS SENSOR CIRCUIT —, Diagnostics Chart with Subaru Select Monitor.>
26	Rear right ABS sensor abnormal signal	Rear right ABS sensor abnormal signal	<Ref. to ABS-112, TROUBLE CODE 26 — REAR RIGHT ABNORMAL ABS SENSOR SIGNAL —, Diagnostics Chart with Subaru Select Monitor.>
27	Open or short circuit in rear left ABS sensor circuit	Open or short circuit in rear left ABS sensor circuit	<Ref. to ABS-106, TROUBLE CODE 27 — OPEN OR SHORT CIRCUIT IN REAR LEFT ABS SENSOR CIRCUIT —, Diagnostics Chart with Subaru Select Monitor.>
28	Rear left ABS sensor abnormal signal	Rear left ABS sensor abnormal signal	<Ref. to ABS-114, TROUBLE CODE 28 — REAR LEFT ABNORMAL ABS SENSOR SIGNAL —, Diagnostics Chart with Subaru Select Monitor.>
29	Abnormal ABS sensor signal on any one of four sensor	Abnormal ABS sensor signal on any one of four	<Ref. to ABS-120, TROUBLE CODE 29 — ABNORMAL ABS SENSOR SIGNAL ON ANY ONE OF FOUR SENSOR —, Diagnostics Chart with Subaru Select Monitor.>
31	Front right inlet valve malfunction	Front right inlet valve malfunction	<Ref. to ABS-124, TROUBLE CODE 31 — FRONT RIGHT INLET VALVE MALFUNCTION —, Diagnostics Chart with Subaru Select Monitor.>
32	Front right outlet valve malfunction	Front right outlet valve malfunction	<Ref. to ABS-129, TROUBLE CODE 32 — FRONT RIGHT OUTLET VALVE MALFUNCTION —, Diagnostics Chart with Subaru Select Monitor.>
33	Front left inlet valve malfunction	Front left inlet valve malfunction	<Ref. to ABS-124, TROUBLE CODE 33 — FRONT LEFT INLET VALVE MALFUNCTION —, Diagnostics Chart with Subaru Select Monitor.>
34	Front left outlet valve malfunction	Front left outlet valve malfunction	<Ref. to ABS-129, TROUBLE CODE 34 — FRONT LEFT OUTLET VALVE MALFUNCTION —, Diagnostics Chart with Subaru Select Monitor.>
35	Rear right inlet valve malfunction	Rear right inlet valve malfunction	<Ref. to ABS-124, TROUBLE CODE 35 — REAR RIGHT INLET VALVE MALFUNCTION —, Diagnostics Chart with Subaru Select Monitor.>
36	Rear right outlet valve malfunction	Rear right outlet valve malfunction	<Ref. to ABS-129, TROUBLE CODE 36 — REAR RIGHT OUTLET VALVE MALFUNCTION —, Diagnostics Chart with Subaru Select Monitor.>
37	Rear left inlet valve malfunction	Rear left inlet valve malfunction	<Ref. to ABS-126, TROUBLE CODE 37 — REAR LEFT INLET VALVE MALFUNCTION —, Diagnostics Chart with Subaru Select Monitor.>

LIST OF DIAGNOSTICS TROUBLE CODE

ABS (DIAGNOSTICS)

Code	Display screen	Contents of diagnosis	Index No.
38	Rear left outlet valve malfunction	Rear left outlet valve malfunction	<Ref. to ABS-130, TROUBLE CODE 38 — REAR LEFT OUTLET VALVE MALFUNCTION —, Diagnostics Chart with Subaru Select Monitor.>
41	ABS control module malfunction	ABS control module and hydraulic control unit malfunction	<Ref. to ABS-134, TROUBLE CODE 41 — ABS CONTROL MODULE MALFUNCTION —, Diagnostics Chart with Subaru Select Monitor.>
42	Power supply voltage too low	Power supply voltage too low	<Ref. to ABS-136, TROUBLE CODE 42 — POWER SUPPLY VOLTAGE TOO LOW —, Diagnostics Chart with Subaru Select Monitor.>
42	Power supply voltage too high	Power supply voltage too high	<Ref. to ABS-138, TROUBLE CODE 42 — POWER SUPPLY VOLTAGE TOO HIGH —, Diagnostics Chart with Subaru Select Monitor.>
44	ABS-AT control (Non Controlled)	ABS-AT control (Non Controlled)	<Ref. to ABS-142, TROUBLE CODE 44 — ABS-AT CONTROL (NON CONTROLLED) —, Diagnostics Chart with Subaru Select Monitor.>
44	ABS-AT control (Controlled)	ABS-AT control (Controlled)	<Ref. to ABS-144, TROUBLE CODE 44 — ABS-AT CONTROL (CONTROLLED) —, Diagnostics Chart with Subaru Select Monitor.>
51	Valve relay malfunction	Valve relay malfunction	<Ref. to ABS-147, TROUBLE CODE 51 — VALVE RELAY MALFUNCTION —, Diagnostics Chart with Subaru Select Monitor.>
51	Valve relay ON failure	Valve relay ON failure	<Ref. to ABS-151, TROUBLE CODE 51 — VALVE RELAY ON FAILURE —, Diagnostics Chart with Subaru Select Monitor.>
52	Open circuit in motor relay circuit	Open circuit in motor relay circuit	<Ref. to ABS-155, TROUBLE CODE 52 — OPEN CIRCUIT IN MOTOR RELAY CIRCUIT —, Diagnostics Chart with Subaru Select Monitor.>
52	Motor relay ON failure	Motor relay ON failure	<Ref. to ABS-159, TROUBLE CODE 52 — MOTOR RELAY ON FAILURE —, Diagnostics Chart with Subaru Select Monitor.>
52	Motor malfunction	Motor malfunction	<Ref. to ABS-163, TROUBLE CODE 52 — MOTOR MALFUNCTION —, Diagnostics Chart with Subaru Select Monitor.>
54	Stop light switch signal circuit malfunction	Stop light switch signal circuit malfunction	<Ref. to ABS-166, TROUBLE CODE 54 — STOP LIGHT SWITCH SIGNAL CIRCUIT MALFUNCTION —, Diagnostics Chart with Subaru Select Monitor.>
56	Open or short circuit in G sensor circuit	Open or short circuit in G sensor circuit	<Ref. to ABS-168, TROUBLE CODE 56 — OPEN OR SHORT CIRCUIT IN G SENSOR CIRCUIT —, Diagnostics Chart with Subaru Select Monitor.>
56	Battery short in G sensor circuit	Battery short in G sensor circuit	<Ref. to ABS-172, TROUBLE CODE 56 — BATTERY SHORT IN G SENSOR CIRCUIT —, Diagnostics Chart with Subaru Select Monitor.>
56	Abnormal G sensor high μ output	Abnormal G sensor high μ output	<Ref. to ABS-178, TROUBLE CODE 56 — ABNORMAL G SENSOR HIGH μ OUTPUT —, Diagnostics Chart with Subaru Select Monitor.>
56	Detection of G sensor stick	Detection of G sensor stick	<Ref. to ABS-182, TROUBLE CODE 56 — DETECTION OF G SENSOR STICK —, Diagnostics Chart with Subaru Select Monitor.>

NOTE:

High μ means high friction coefficient against road surface.

DIAGNOSTICS CHART WITH DIAGNOSIS CONNECTOR

ABS (DIAGNOSTICS)

12. Diagnostics Chart with Diagnosis Connector

A: ABS WARNING LIGHT DOES NOT COME ON.

DIAGNOSIS:

- ABS warning light circuit is open or shorted.

TROUBLE SYMPTOM:

- When ignition switch is turned ON (engine OFF), ABS warning light does not come on.

WIRING DIAGRAM: LHD MODEL

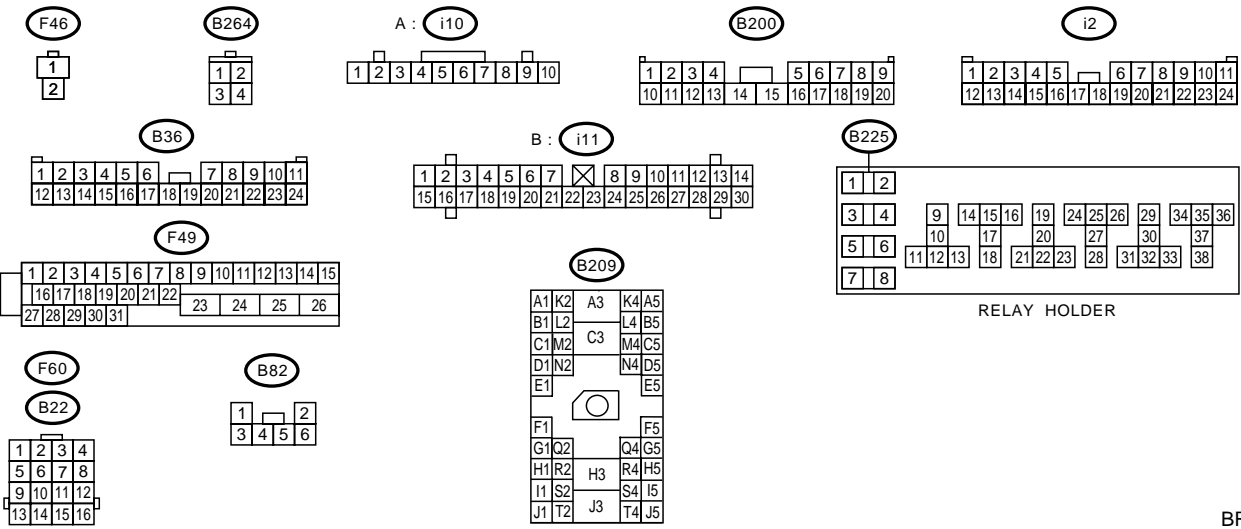
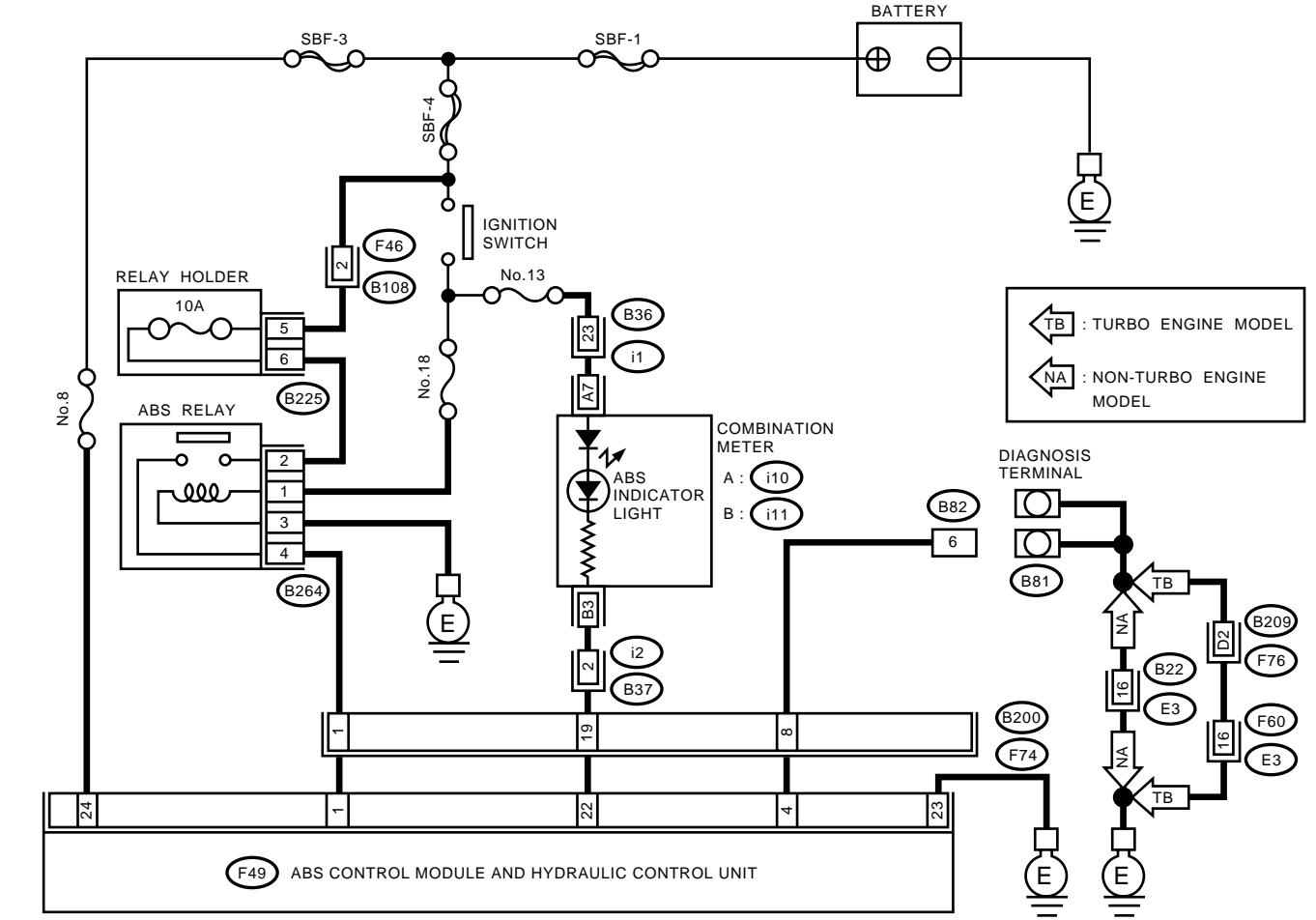

BR0035

DIAGNOSTICS CHART WITH DIAGNOSIS CONNECTOR

ABS (DIAGNOSTICS)

WIRING DIAGRAM: RHD MODEL

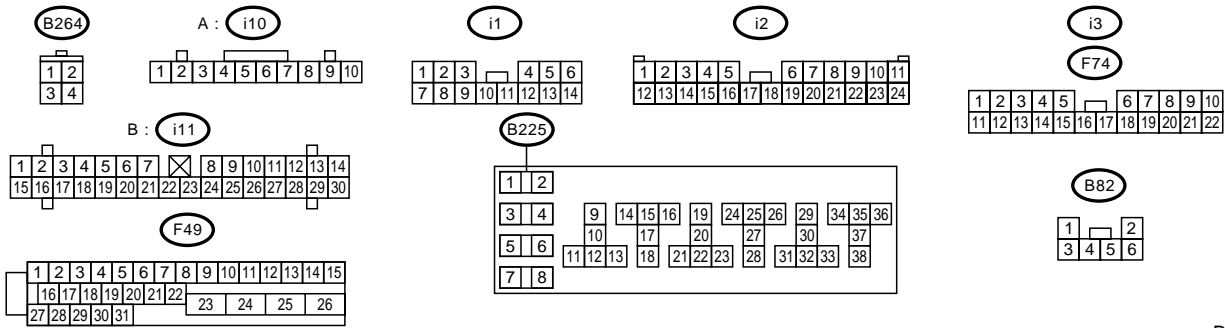
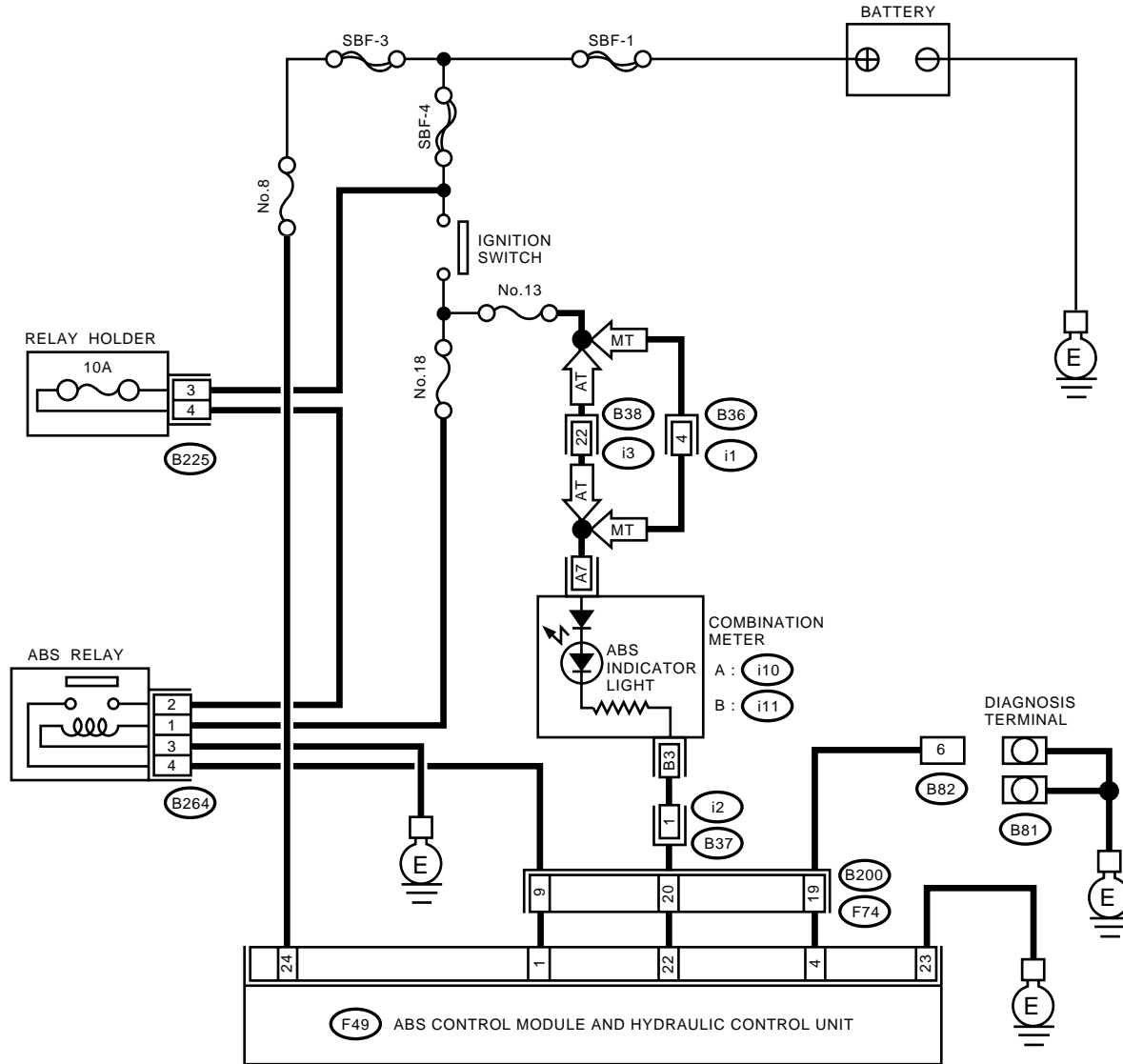

BR0036

DIAGNOSTICS CHART WITH DIAGNOSIS CONNECTOR

ABS (DIAGNOSTICS)

	Step	Check	Yes	No
1	CHECK IF OTHER WARNING LIGHTS TURN ON. Turn ignition switch to ON (engine OFF).	Do other warning lights turn on?	Go to step 2.	Repair combination meter. <Ref. to IDI-19, Combination Meter Assembly.>
2	CHECK ABS WARNING LIGHT BULB. 1) Turn ignition switch to OFF. 2) Remove combination meter. 3) Remove ABS warning light bulb from combination meter.	Is ABS warning light bulb OK?	Go to step 3.	Replace ABS warning light bulb. <Ref. to IDI-19, Combination Meter Assembly.>
3	CHECK BATTERY SHORT OF ABS WARNING LIGHT HARNESS. 1) Disconnect connector (B200) from connector (F74). 2) Measure voltage between connector (B200) and chassis ground. Connector & terminal LHD: (B200) No. 19 (+) — Chassis ground (-): RHD: (B200) No .20 (+) — Chassis ground (-):	Is the voltage less than 3 V?	Go to step 4.	Repair warning light harness.
4	CHECK BATTERY SHORT OF ABS WARNING LIGHT HARNESS. 1) Turn ignition switch to ON. 2) Measure voltage between connector (B200) and chassis ground. Connector & terminal LHD: (B200) No. 19 (+) — Chassis ground (-): RHD: (B200) No .20 (+) — Chassis ground (-):	Is the voltage less than 3 V?	Go to step 5.	Repair warning light harness.
5	CHECK WIRING HARNESS. 1) Turn ignition switch to OFF. 2) Install ABS warning light bulb from combination meter. 3) Install combination meter. 4) Turn ignition switch to ON. 5) Measure voltage between connector (B200) and chassis ground. Connector & terminal LHD: (B200) No. 19 (+) — Chassis ground (-): RHD: (B200) No .20 (+) — Chassis ground (-):	Is the voltage between 10 and 15 V?	Go to step 6.	Repair wiring harness.
6	CHECK BATTERY SHORT OF ABS WARNING LIGHT HARNESS. 1) Turn ignition switch to OFF. 2) Measure voltage between connector (F74) and chassis ground. Connector & terminal LHD: (F74) No. 19 (+) — Chassis ground (-): RHD: (F74) No .20 (+) — Chassis ground (-):	Is the voltage less than 3 V?	Go to step 7.	Repair wiring harness.

DIAGNOSTICS CHART WITH DIAGNOSIS CONNECTOR

ABS (DIAGNOSTICS)

Step	Check	Yes	No
7 CHECK BATTERY SHORT OF ABS WARNING LIGHT HARNESS. 1) Turn ignition switch to ON. 2) Measure voltage between connector (F74) and chassis ground. Connector & terminal LHD: (F74) No. 19 (+) — Chassis ground (-): RHD: (F74) No .20 (+) — Chassis ground (-):	Is the voltage less than 3 V?	Go to step 8 .	Repair wiring harness.
8 CHECK GROUND CIRCUIT OF ABSCM&H/U. Measure resistance between ABSCM&H/U and chassis ground. Connector & terminal (F49) No. 23 — GND:	Is the resistance less than 0.5 Ω ?	Go to step 9 .	Repair ABSCM&H/U ground harness.
9 CHECK WIRING HARNESS. Measure resistance between connector (F74) and chassis ground. Connector & terminal LHD: (F74) No. 19 (+) — Chassis ground (-): RHD: (F74) No .20 (+) — Chassis ground (-):	Is the resistance less than 0.5 Ω ?	Go to step 10 .	Repair harness/connector.
10 CHECK POOR CONTACT IN CONNECTORS. Turn ignition switch to OFF.	Is there poor contact in connectors between combination meter and ABSCM&H/U?	Repair connector.	Replace ABSCM&H/U. <Ref. to ABS-7, ABS Control Module and Hydraulic Control Unit (ABSCM&H/U).>

DIAGNOSTICS CHART WITH DIAGNOSIS CONNECTOR

ABS (DIAGNOSTICS)

B: ABS WARNING LIGHT DOES NOT GO OFF.

DIAGNOSIS:

- ABS warning light circuit is open or shorted.

TROUBLE SYMPTOM:

- When starting the engine and while ABS warning light is kept ON.

WIRING DIAGRAM: LHD MODEL

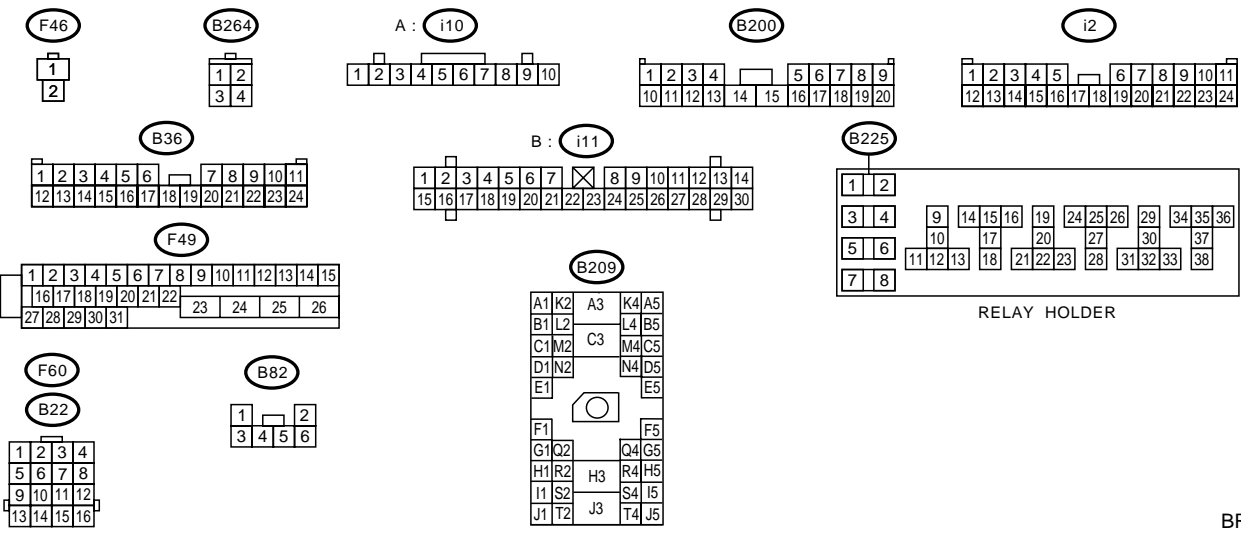
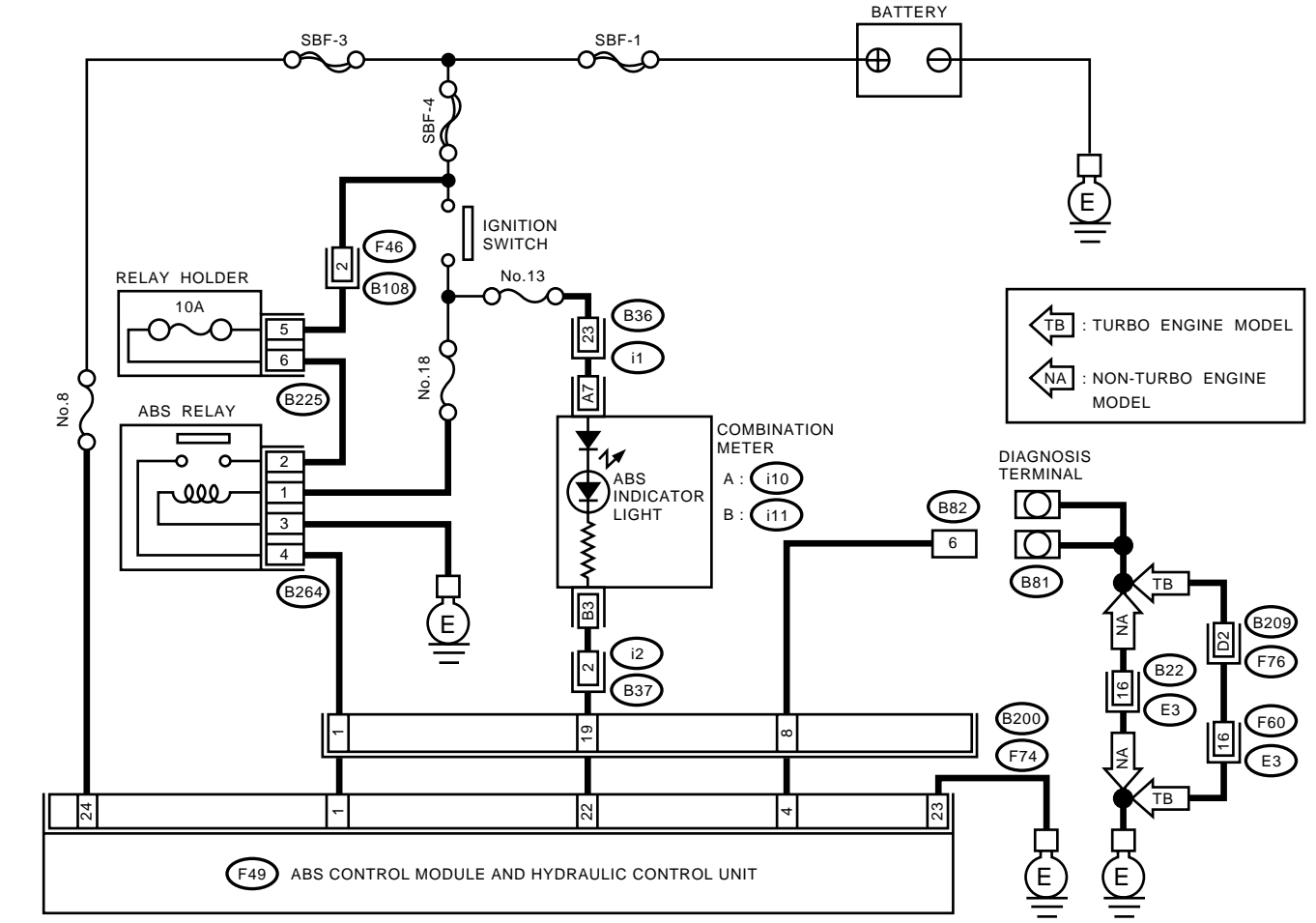

BR0035

DIAGNOSTICS CHART WITH DIAGNOSIS CONNECTOR

ABS (DIAGNOSTICS)

WIRING DIAGRAM: RHD MODEL

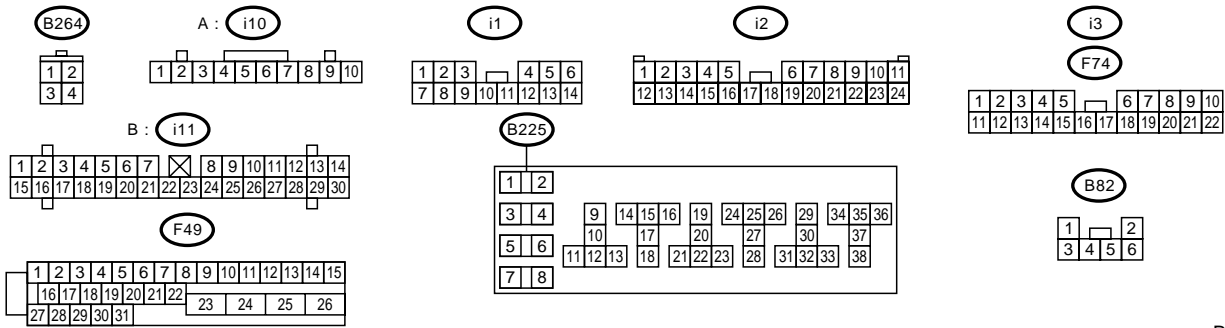
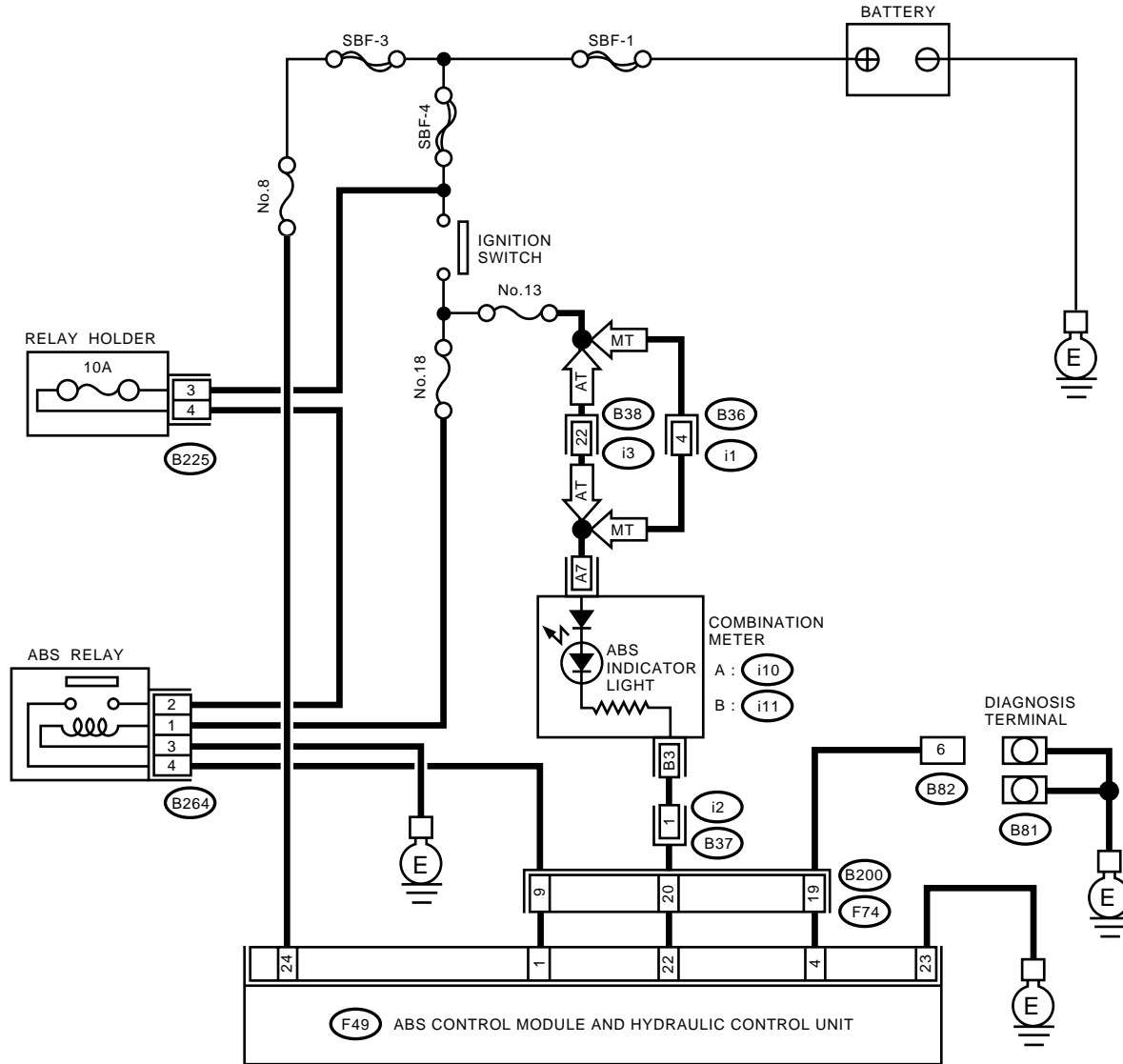

BR0036

DIAGNOSTICS CHART WITH DIAGNOSIS CONNECTOR

ABS (DIAGNOSTICS)

Step	Check	Yes	No	
1	CHECK INSTALLATION OF ABSCM&H/U CONNECTOR. Turn ignition switch to OFF.	Is ABSCM&H/U connector inserted into ABSCM until the clamp locks onto it?	Go to step 2.	Insert ABSCM&H/U connector into ABSCM&H/U until the clamp locks onto it.
2	CHECK DIAGNOSIS TERMINAL. Measure resistance between diagnosis terminals (B81) and chassis ground. Terminals Diagnosis terminal (A) — Chassis ground: Diagnosis terminal (B) — Chassis ground:	Is the resistance less than 0.5 Ω?	Go to step 3.	Repair diagnosis terminal harness.
3	CHECK DIAGNOSIS LINE. 1)Turn ignition switch to OFF. 2)Connect diagnosis terminal (B81) to diagnosis connector (B82) No. 6. 3)Disconnect connector from ABSCM&H/U. 4)Measure resistance between ABSCM&H/U connector and chassis ground. Connector & terminal (F49) No. 4 — Chassis ground:	Is the resistance less than 0.5 Ω?	Go to step 4.	Repair harness connector between ABSCM&H/U and diagnosis connector.
4	CHECK GENERATOR. 1)Start the engine. 2)Idle the engine. 3)Measure voltage between generator and chassis ground. Terminal Generator B terminal (+) — Chassis ground (-):	Is the voltage between 10 and 15 V?	Go to step 5.	Repair generator. <Ref. to SC-12, Generator.>
5	CHECK BATTERY TERMINAL. Turn ignition switch to OFF.	Is there poor contact at battery terminal?	Repair battery terminal.	Go to step 6.
6	CHECK POWER SUPPLY OF ABSCM. 1)Disconnect connector from ABSCM&H/U. 2)Start engine. 3)Idle the engine. 4)Measure voltage between ABSCM&H/U connector and chassis ground. Connector & terminal (F49) No. 1 (+) — Chassis ground (-):	Is the voltage between 10 and 15 V?	Go to step 7.	Repair ABSCM&H/U power supply circuit.
7	CHECK WIRING HARNESS. 1)Disconnect connector (F74) from connector (B200). 2)Turn ignition switch to ON.	Does the ABS warning light remain off?	Go to step 8.	Repair front wiring harness.
8	CHECK PROJECTION AT ABSCM&H/U. 1)Turn ignition switch to OFF. 2)Check for broken projection at the ABSCM&H/U terminal.	Are the projection broken?	Go to step 9.	Replace ABSCM&H/U. <Ref. to ABS-7, ABS Control Module and Hydraulic Control Unit (ABSCM&H/U).>
9	CHECK ABSCM&H/U. Measure resistance between ABSCM&H/U terminals. Terminal No. 22 — No. 23:	Is the resistance more than 1 MΩ?	Go to step 10.	Replace ABSCM&H/U. <Ref. to ABS-7, ABS Control Module and Hydraulic Control Unit (ABSCM&H/U).>

DIAGNOSTICS CHART WITH DIAGNOSIS CONNECTOR

ABS (DIAGNOSTICS)

Step	Check	Yes	No
10 CHECK WIRING HARNESS. Measure resistance between connector (F74) and chassis ground. <i>Connector & terminal</i> <i>(F74) No. 20 — Chassis ground:</i>	Is the resistance less than 0.5 Ω ?	Go to step 11.	Repair harness.
11 CHECK WIRING HARNESS. 1)Connect connector to ABSCM&H/U. 2)Measure resistance between connector (F74) and chassis ground. <i>Connector & terminal</i> <i>(F74) No. 20 — Chassis ground:</i>	Is the resistance more than 1 M Ω ?	Go to step 12.	Repair harness.
12 CHECK POOR CONTACT IN ABSCM&H/U CONNECTOR.	Is there poor contact in ABSCM&H/U connector?	Repair connector.	Replace ABSCM&H/U. <Ref. to ABS-7, ABS Control Module and Hydraulic Control Unit (ABSCM&H/U).>

DIAGNOSTICS CHART WITH DIAGNOSIS CONNECTOR

ABS (DIAGNOSTICS)

C: TROUBLE CODE DOES NOT APPEAR.

DIAGNOSIS:

- Diagnosis circuit is open.

TROUBLE SYMPTOM:

- The ABS warning light turns on or off normally but the start code cannot be read out in the diagnostic mode.

WIRING DIAGRAM: LHD MODEL

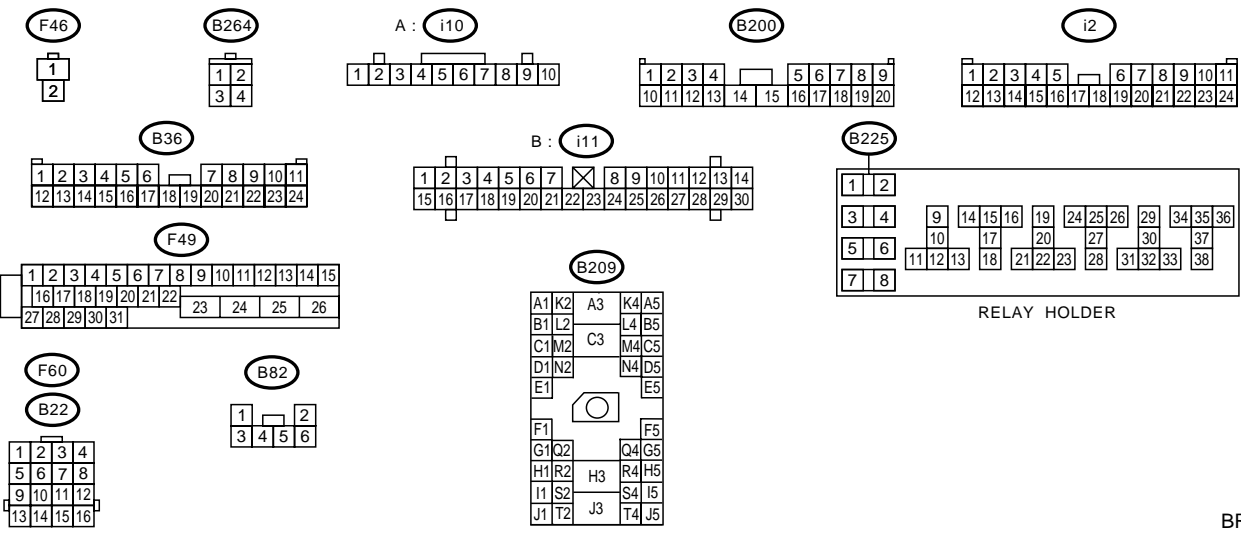
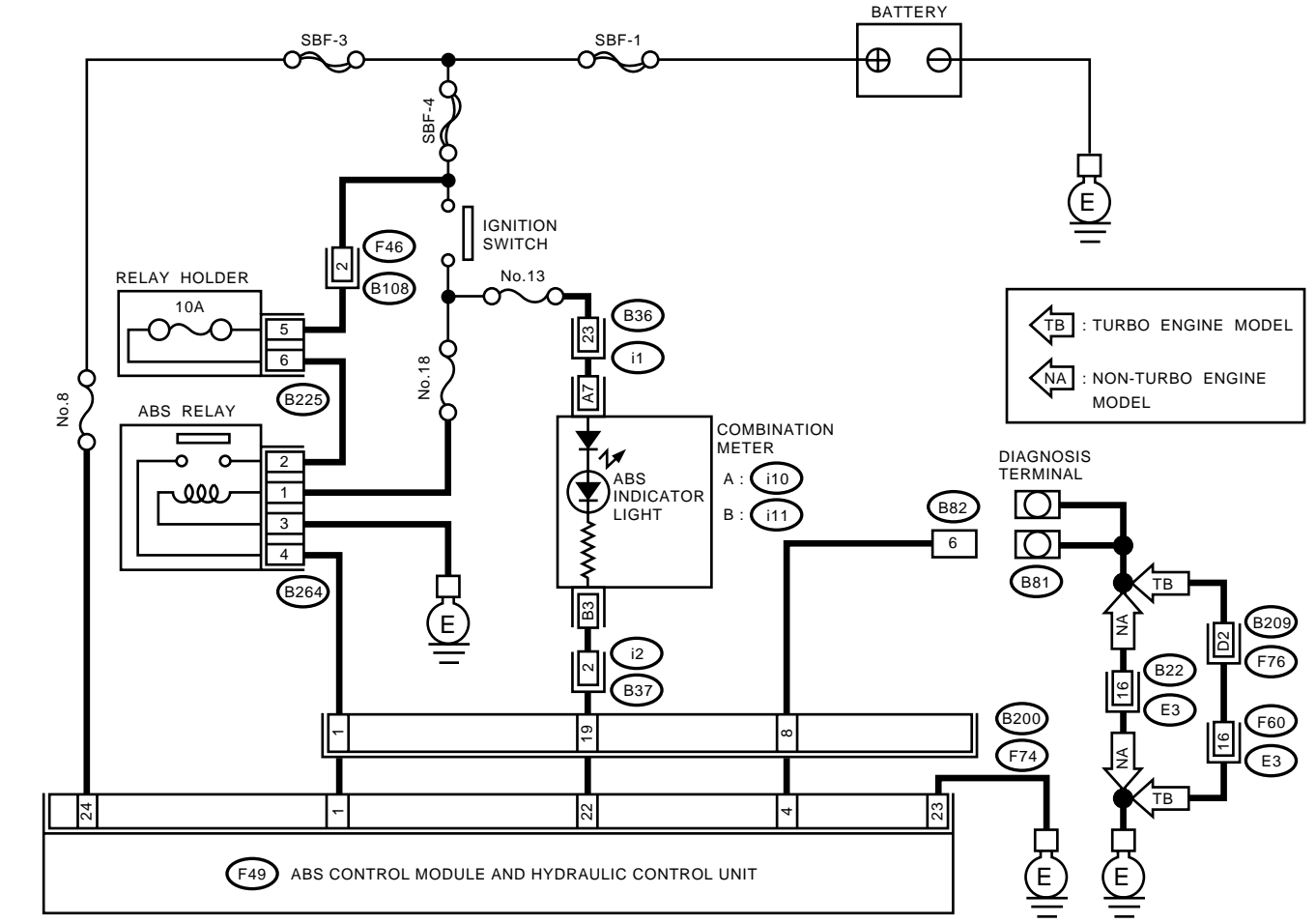

BR0035

DIAGNOSTICS CHART WITH DIAGNOSIS CONNECTOR

ABS (DIAGNOSTICS)

WIRING DIAGRAM: RHD MODEL

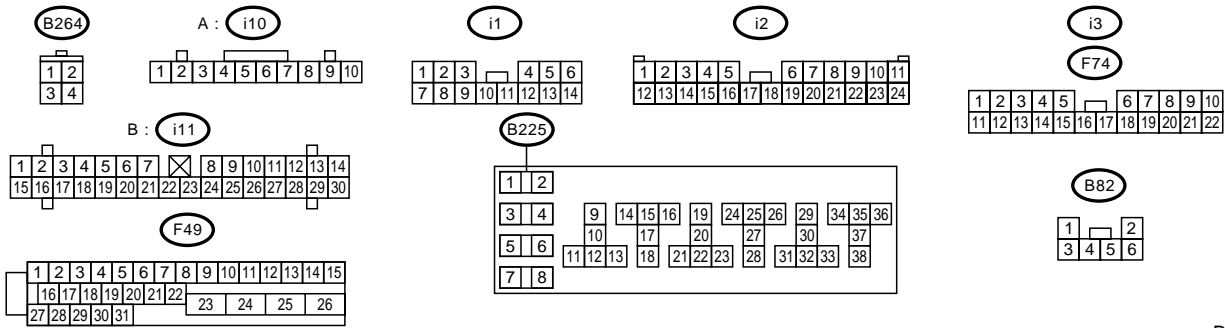
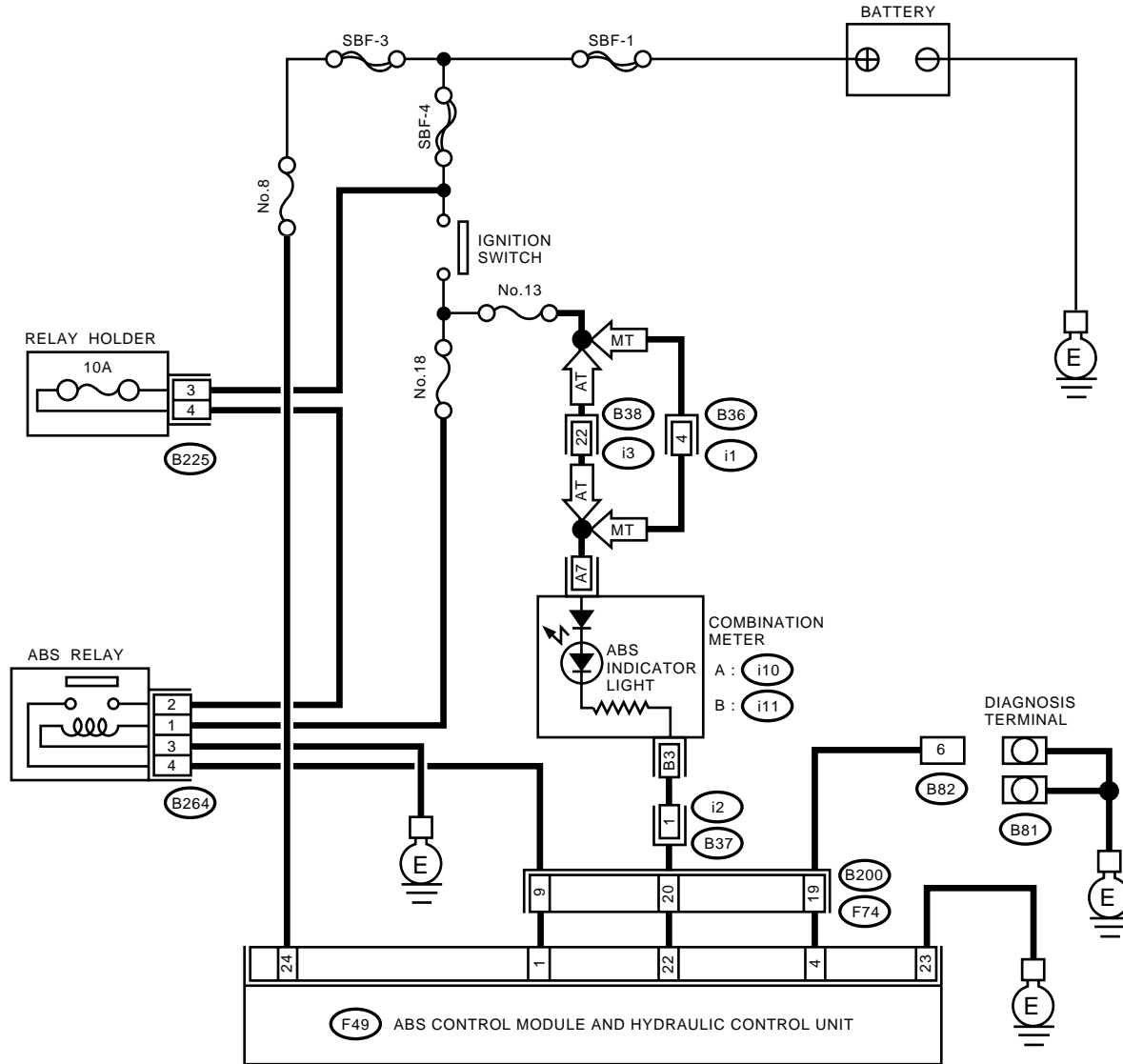

BR0036

DIAGNOSTICS CHART WITH DIAGNOSIS CONNECTOR

ABS (DIAGNOSTICS)

Step	Check	Yes	No
1 CHECK DIAGNOSIS TERMINAL. 1) Turn ignition switch to OFF. 2) Measure resistance between diagnosis terminals (B81) and chassis ground. Terminals <i>Diagnosis terminal (A) — Chassis ground:</i> <i>Diagnosis terminal (B) — Chassis ground:</i>	Is the resistance less than 0.5 Ω ?	Go to step 2.	Repair diagnosis terminal harness.
2 CHECK DIAGNOSIS LINE. 1) Turn ignition switch to OFF. 2) Connect diagnosis terminal (B81) to diagnosis connector (B82) No. 6. 3) Disconnect connector from ABSCM&H/U. 4) Measure resistance between ABSCM&H/U connector and chassis ground. Connector & terminal <i>(F49) No. 4 — Chassis ground:</i>	Is the resistance less than 0.5 Ω ?	Go to step 3.	Repair harness connector between ABSCM&H/U and diagnosis connector.
3 CHECK POOR CONTACT IN ABSCM&H/U CONNECTOR.	Is there poor contact in ABSCM&H/U connector?	Repair connector.	Replace ABSCM&H/U. <Ref. to ABS-7, ABS Control Module and Hydraulic Control Unit (ABSCM&H/U).>

D: TROUBLE CODE 21

— ABNORMAL ABS SENSOR (OPEN CIRCUIT OR INPUT VOLTAGE TOO HIGH) (FRONT RH) —

NOTE:

For the diagnostic procedure, refer to TROUBLE CODE 27. <Ref. to ABS-40, TROUBLE CODE 27 — ABNORMAL ABS SENSOR (OPEN CIRCUIT OR INPUT VOLTAGE TOO HIGH) (REAR LH) —, Diagnostics Chart with Diagnosis Connector.>

E: TROUBLE CODE 23

— ABNORMAL ABS SENSOR (OPEN CIRCUIT OR INPUT VOLTAGE TOO HIGH) (FRONT LH) —

NOTE:

For the diagnostic procedure, refer to TROUBLE CODE 27. <Ref. to ABS-40, TROUBLE CODE 27 — ABNORMAL ABS SENSOR (OPEN CIRCUIT OR INPUT VOLTAGE TOO HIGH) (REAR LH) —, Diagnostics Chart with Diagnosis Connector.>

F: TROUBLE CODE 25

— ABNORMAL ABS SENSOR (OPEN CIRCUIT OR INPUT VOLTAGE TOO HIGH) (REAR RH) —

NOTE:

For the diagnostic procedure, refer to TROUBLE CODE 27. <Ref. to ABS-40, TROUBLE CODE 27 — ABNORMAL ABS SENSOR (OPEN CIRCUIT OR INPUT VOLTAGE TOO HIGH) (REAR LH) —, Diagnostics Chart with Diagnosis Connector.>

DIAGNOSTICS CHART WITH DIAGNOSIS CONNECTOR

ABS (DIAGNOSTICS)

G: TROUBLE CODE 27

— ABNORMAL ABS SENSOR (OPEN CIRCUIT OR INPUT VOLTAGE TOO HIGH) (REAR LH) —

DIAGNOSIS:

- Faulty ABS sensor (Broken wire, input voltage too high)
- Faulty harness connector

TROUBLE SYMPTOM:

- ABS does not operate.

DIAGNOSTICS CHART WITH DIAGNOSIS CONNECTOR

ABS (DIAGNOSTICS)

WIRING DIAGRAM: LHD MODEL

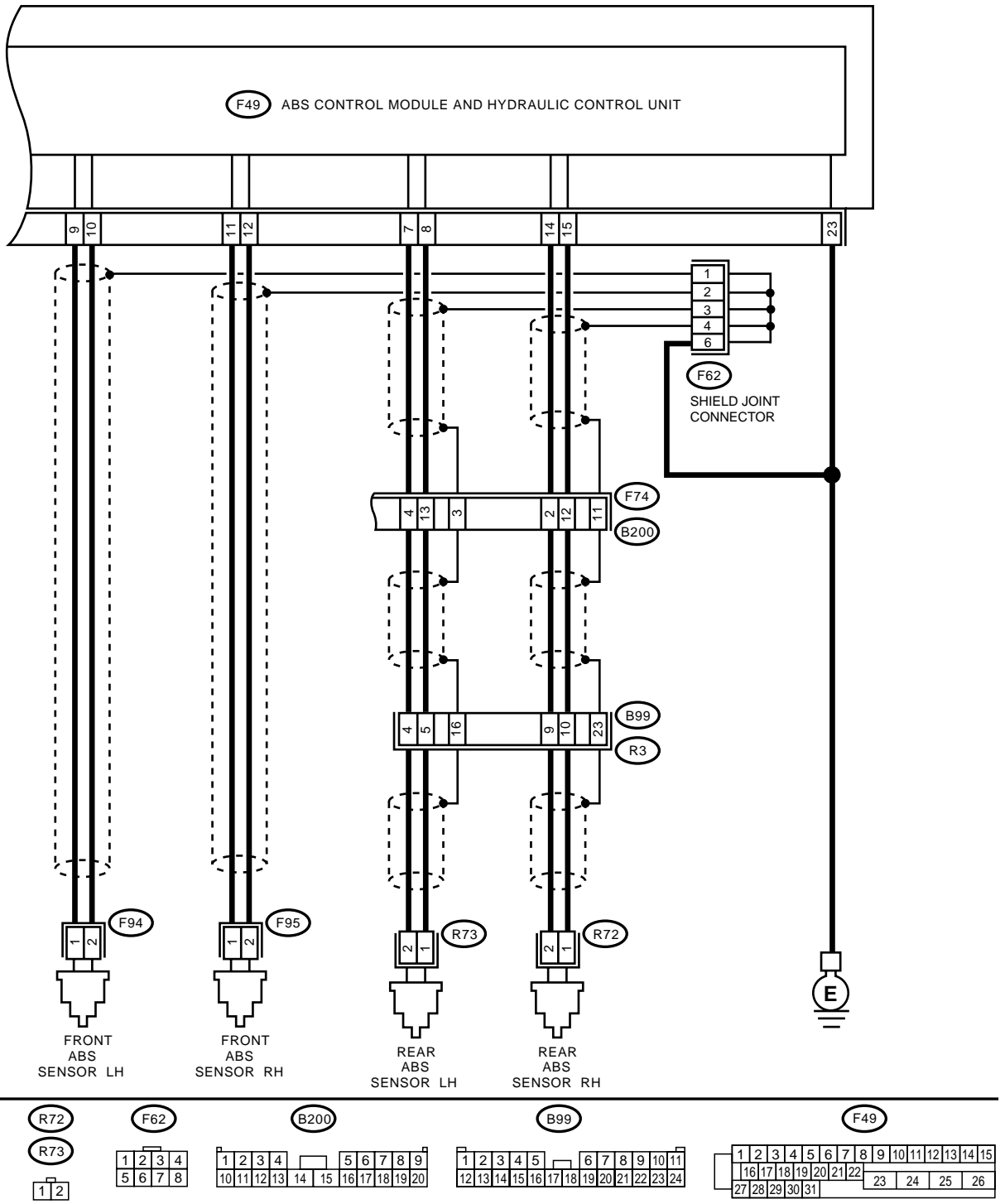

BR0037

DIAGNOSTICS CHART WITH DIAGNOSIS CONNECTOR

ABS (DIAGNOSTICS)

WIRING DIAGRAM: RHD MODEL

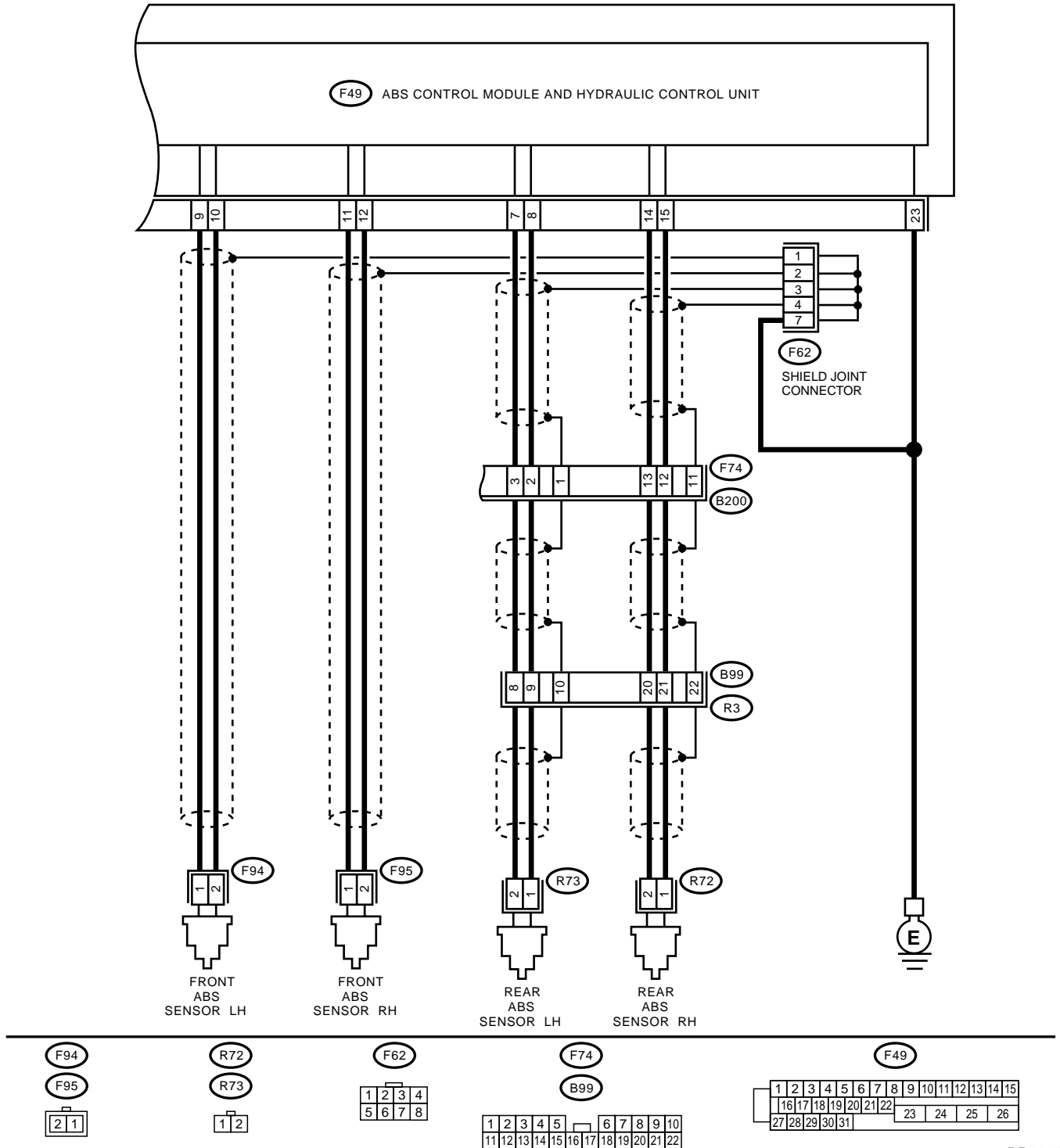

BR0038

DIAGNOSTICS CHART WITH DIAGNOSIS CONNECTOR

ABS (DIAGNOSTICS)

Step	Check	Yes	No
<p>1 CHECK ABS SENSOR. 1) Turn ignition switch to OFF. 2) Disconnect connector from ABS sensor. 3) Measure resistance of ABS sensor connector terminals.</p> <p>Terminal Front RH No. 1 — No. 2: Front LH No. 1 — No. 2: Rear RH No. 1 — No. 2: Rear LH No. 1 — No. 2:</p>	Is the resistance between 1 and 1.5 kΩ?	Go to step 2.	Replace ABS sensor. Front: <Ref. to ABS-14, Front ABS Sensor.> Rear: <Ref. to ABS-17, Rear ABS Sensor.>
<p>2 CHECK BATTERY SHORT OF ABS SENSOR. 1) Disconnect connector from ABSCM&H/U. 2) Measure voltage between ABS sensor and chassis ground.</p> <p>Terminal Front RH No. 1 (+) — Chassis ground (-): Front LH No. 1 (+) — Chassis ground (-): Rear RH No. 2 (+) — Chassis ground (-): Rear LH No. 2 (+) — Chassis ground (-):</p>	Is the voltage less than 1 V?	Go to step 3.	Replace ABS sensor. Front: <Ref. to ABS-14, Front ABS Sensor.> Rear: <Ref. to ABS-17, Rear ABS Sensor.>
<p>3 CHECK BATTERY SHORT OF ABS SENSOR. 1) Turn ignition switch to ON. 2) Measure voltage between ABS sensor and chassis ground.</p> <p>Terminal Front RH No. 1 (+) — Chassis ground (-): Front LH No. 1 (+) — Chassis ground (-): Rear RH No. 2 (+) — Chassis ground (-): Rear LH No. 2 (+) — Chassis ground (-):</p>	Is the voltage less than 1 V?	Go to step 4.	Replace ABS sensor. Front: <Ref. to ABS-14, Front ABS Sensor.> Rear: <Ref. to ABS-17, Rear ABS Sensor.>
<p>4 CHECK HARNESS/CONNECTOR BETWEEN ABSCM&H/U AND ABS SENSOR. 1) Turn ignition switch to OFF. 2) Connect connector to ABS sensor. 3) Measure resistance between ABSCM&H/U connector terminals.</p> <p>Connector & terminal Trouble code 21 / (F49) No. 11 — No. 12: Trouble code 23 / (F49) No. 9 — No. 10: Trouble code 25 / (F49) No. 14 — No. 15: Trouble code 27 / (F49) No. 7 — No. 8:</p>	Is the resistance between 1 and 1.5 kΩ?	Go to step 5.	Repair harness/connector between ABSCM&H/U and ABS sensor.
<p>5 CHECK BATTERY SHORT OF HARNESS. Measure voltage between ABSCM&H/U connector and chassis ground.</p> <p>Connector & terminal Trouble code 21 / (F49) No. 11 (+) — Chassis ground (-): Trouble code 23 / (F49) No. 9 (+) — Chassis ground (-): Trouble code 25 / (F49) No. 14 (+) — Chassis ground (-): Trouble code 27 / (F49) No. 7 (+) — Chassis ground (-):</p>	Is the voltage less than 1 V?	Go to step 6.	Repair harness between ABSCM&H/U and ABS sensor.

DIAGNOSTICS CHART WITH DIAGNOSIS CONNECTOR

ABS (DIAGNOSTICS)

Step	Check	Yes	No
6 CHECK BATTERY SHORT OF HARNESS. 1) Turn ignition switch to ON. 2) Measure voltage between ABSCM&H/U connector and chassis ground. Connector & terminal <i>Trouble code 21 / (F49) No. 11 (+) — Chassis ground (-):</i> <i>Trouble code 23 / (F49) No. 9 (+) — Chassis ground (-):</i> <i>Trouble code 25 / (F49) No. 14 (+) — Chassis ground (-):</i> <i>Trouble code 27 / (F49) No. 7 (+) — Chassis ground (-):</i>	Is the voltage less than 1 V?	Go to step 7.	Repair harness between ABSCM&H/U and ABS sensor.
7 CHECK INSTALLATION OF ABS SENSOR. Turn ignition switch to OFF. Tightening torque: 32 N·m (3.3 kgf-m, 24 ft-lb)	Are the ABS sensor installation bolts tightened securely?	Go to step 8.	Tighten ABS sensor installation bolts securely.
8 CHECK ABS SENSOR GAP. Measure tone wheel to ABS sensor piece gap over entire perimeter of the wheel. Front wheel 0.3 — 0.8 mm (0.012 — 0.031 in) Rear wheel 0.7 — 1.2 mm (0.028 — 0.047 in)	Is the gap within the specifications?	Go to step 9.	Adjust the gap. NOTE: Adjust the gap using spacers (Part No. 26755AA000). If spacers cannot correct the gap, replace worn sensor or worn tone wheel.
9 CHECK TONE WHEEL RUNOUT. Measure tone wheel runout.	Is the runout less than 0.05 mm (0.0020 in)?	Go to step 10.	Replace tone wheel. Front: <Ref. to ABS-20, Front Tone Wheel.> Rear: <Ref. to ABS-21, Rear Tone Wheel.>
10 CHECK GROUND SHORT OF ABS SENSOR. 1) Turn ignition switch to ON. 2) Measure resistance between ABS sensor and chassis ground. Terminal Front RH No. 1 — Chassis ground: Front LH No. 1 — Chassis ground: Rear RH No. 1 — Chassis ground: Rear LH No. 1 — Chassis ground:	Is the resistance more than 1 MΩ?	Go to step 11.	Replace ABS sensor and ABSCM&H/U. Front: <Ref. to ABS-14, Front ABS Sensor.> Rear: <Ref. to ABS-17, Rear ABS Sensor.> and <Ref. to ABS-7, ABS Control Module and Hydraulic Control Unit (ABSCM&H/U).>

DIAGNOSTICS CHART WITH DIAGNOSIS CONNECTOR

ABS (DIAGNOSTICS)

Step	Check	Yes	No
11 CHECK GROUND SHORT OF HARNESS. 1) Turn ignition switch to OFF. 2) Connect connector to ABS sensor. 3) Measure resistance between ABSCM&H/U connector terminal and chassis ground. Connector & terminal Trouble code 21 / (F49) No. 11 — Chassis ground: Trouble code 23 / (F49) No. 9 — Chassis ground: Trouble code 25 / (F49) No. 14 — Chassis ground: Trouble code 27 / (F49) No. 7 — Chassis ground:	Is the resistance more than 1 MΩ?	Go to step 12.	Repair harness between ABSCM&H/U and ABS sensor. Replace ABSCM&H/U. <Ref. to ABS-7, ABS Control Module and Hydraulic Control Unit (ABSCM&H/U).>
12 CHECK POOR CONTACT IN CONNECTORS.	Is there poor contact in connectors between ABSCM&H/U and ABS sensor?	Repair connector.	Go to step 13.
13 CHECK ABSCM&H/U. 1) Connect all connectors. 2) Erase the memory. 3) Perform inspection mode. 4) Read out the trouble code.	Is the same trouble code as in the current diagnosis still being output?	Replace ABSCM&H/U. <Ref. to ABS-7, ABS Control Module and Hydraulic Control Unit (ABSCM&H/U).>	Go to step 14.
14 CHECK ANY OTHER TROUBLE CODES APPEARANCE.	Are other trouble codes being output?	Proceed with the diagnosis corresponding to the trouble code.	A temporary poor contact. NOTE: Check harness and connectors between ABSCM&H/U and ABS sensor.

DIAGNOSTICS CHART WITH DIAGNOSIS CONNECTOR

ABS (DIAGNOSTICS)

H: TROUBLE CODE 22 **— ABNORMAL ABS SENSOR (FRONT RH) —**

NOTE:

For the diagnostic procedure, refer to TROUBLE CODE 28. <Ref. to ABS-48, TROUBLE CODE 28 — ABNORMAL ABS SENSOR (REAR LH) —, Diagnostics Chart with Diagnosis Connector.>

I: TROUBLE CODE 24 **— ABNORMAL ABS SENSOR (FRONT LH) —**

NOTE:

For the diagnostic procedure, refer to TROUBLE CODE 28. <Ref. to ABS-48, TROUBLE CODE 28 — ABNORMAL ABS SENSOR (REAR LH) —, Diagnostics Chart with Diagnosis Connector.>

J: TROUBLE CODE 26 **— ABNORMAL ABS SENSOR (REAR RH) —**

NOTE:

For the diagnostic procedure, refer to TROUBLE CODE 28. <Ref. to ABS-48, TROUBLE CODE 28 — ABNORMAL ABS SENSOR (REAR LH) —, Diagnostics Chart with Diagnosis Connector.>

DIAGNOSTICS CHART WITH DIAGNOSIS CONNECTOR

ABS (DIAGNOSTICS)

DIAGNOSTICS CHART WITH DIAGNOSIS CONNECTOR

ABS (DIAGNOSTICS)

K: TROUBLE CODE 28 — ABNORMAL ABS SENSOR (REAR LH) —

DIAGNOSIS:

- Faulty ABS sensor signal (noise, irregular signal, etc.)
- Faulty harness/connector

TROUBLE SYMPTOM:

- ABS does not operate.

WIRING DIAGRAM: LHD MODEL

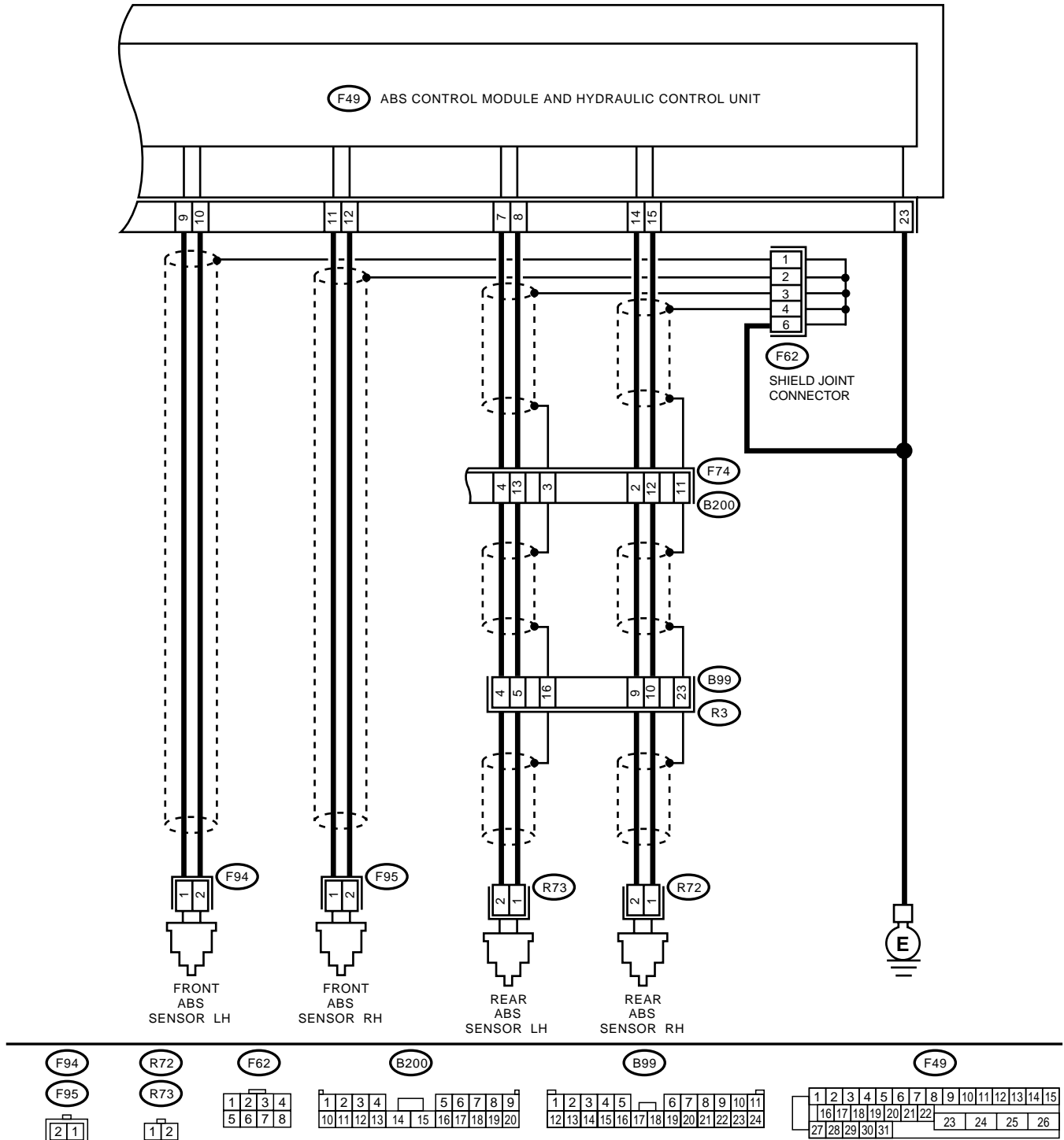

BR0037

DIAGNOSTICS CHART WITH DIAGNOSIS CONNECTOR

ABS (DIAGNOSTICS)

WIRING DIAGRAM: RHD MODEL

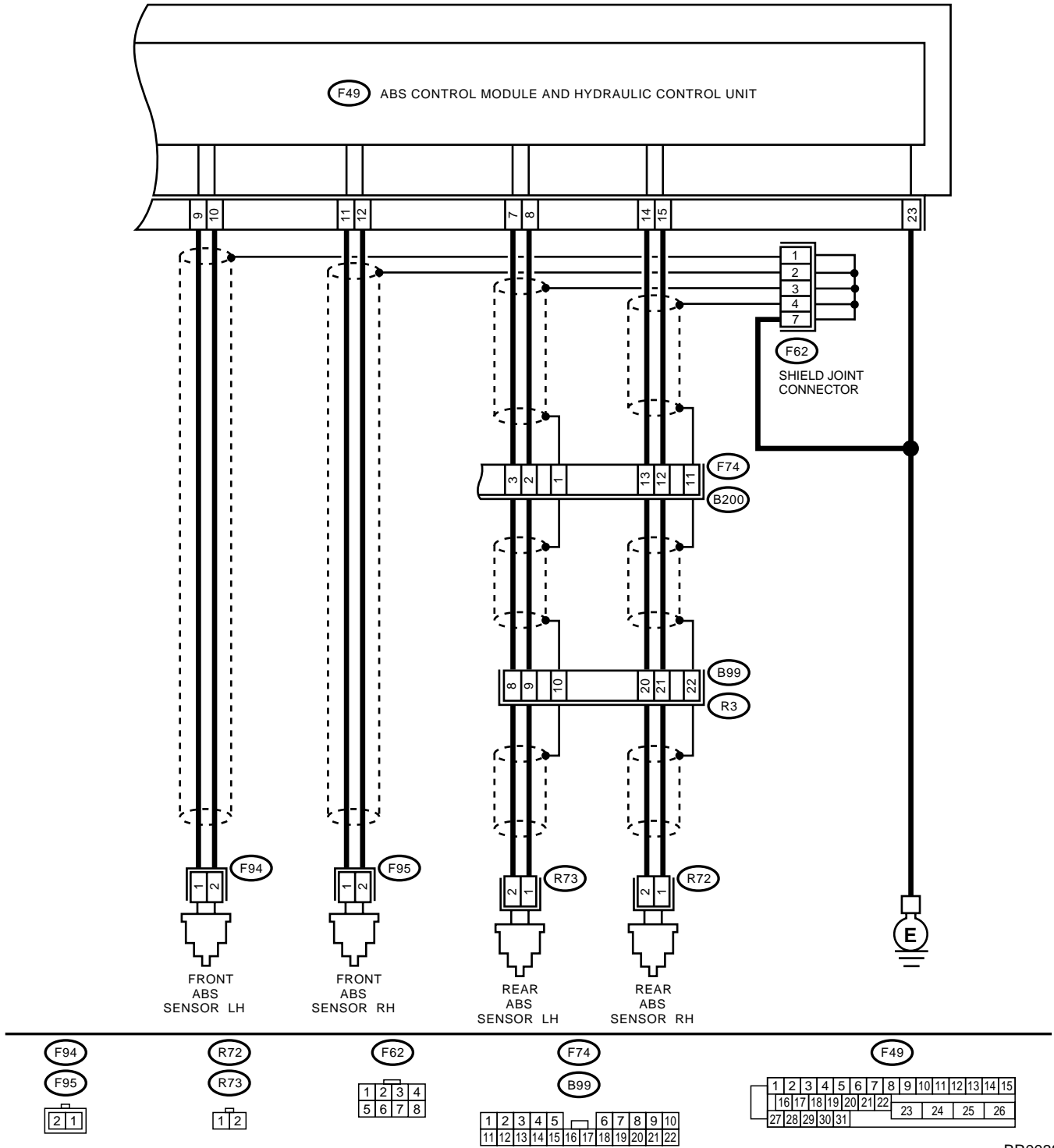

BR0038

DIAGNOSTICS CHART WITH DIAGNOSIS CONNECTOR

ABS (DIAGNOSTICS)

Step	Check	Yes	No
1 CHECK INSTALLATION OF ABS SENSOR. Turn ignition switch to OFF. <i>Tightening torque:</i> 32±10 N·m (3.3±1.0 kgf·m, 24±7 ft·lb)	Are the ABS sensor installation bolts tightened securely?	Go to step 2.	Tighten ABS sensor installation bolts securely.
2 CHECK ABS SENSOR GAP. Measure tone wheel to ABS sensor piece gap over entire perimeter of the wheel. <i>Front wheel</i> 0.3 — 0.8 mm (0.012 — 0.031 in) <i>Rear wheel</i> 0.7 — 1.2 mm (0.028 — 0.047 in)	Is the gap within the specifications?	Go to step 3.	Adjust the gap. NOTE: Adjust the gap using spacer (Part No. 26755AA000). If spacers cannot correct the gap, replace worn sensor or worn tone wheel.
3 PREPARE OSCILLOSCOPE.	Is an oscilloscope available?	Go to step 4.	Go to step 5.
4 CHECK ABS SENSOR SIGNAL. 1) Raise all four wheels of ground. 2) Turn ignition switch OFF. 3) Connect the oscilloscope to the connector. 4) Turn ignition switch ON. 5) Rotate wheels and measure voltage at specified frequency. <Ref. to ABS-17, WAVEFORM, Control Module I/O Signal.> NOTE: When this inspection is completed, the ABS control module sometimes stores the trouble code 29. <i>Connector & terminal</i> <i>Trouble code 22 /</i> <i>(F95) No. 1 (+) — No. 2 (-):</i> <i>Trouble code 24 /</i> <i>(F94) No. 1 (+) — No. 2 (-):</i> <i>Trouble code 26 /</i> <i>LHD: (B99) No. 9 (+) — No. 10 (-):</i> <i>RHD: (B99) No. 20 (+) — No. 21 (-):</i> <i>Trouble code 28 /</i> <i>LHD: (B99) No. 4 (+) — No. 5 (-):</i> <i>RHD: (B99) No. 8 (+) — No. 9 (-):</i>	Is oscilloscope pattern smooth, as shown in figure?	Go to step 8.	Go to step 7.
5 CHECK CONTAMINATION OF ABS SENSOR OR TONE WHEEL. Remove disc rotor or drum from hub in accordance with trouble code.	Is the ABS sensor piece or the tone wheel contaminated by dirt or other foreign matter?	Thoroughly remove dirt or other foreign matter.	Go to step 6.
6 CHECK DAMAGE OF ABS SENSOR OR TONE WHEEL.	Are there broken or damaged in the ABS sensor piece or the tone wheel?	Replace ABS sensor or tone wheel. Front: <Ref. to ABS-14, Front ABS Sensor.> Rear: <Ref. to ABS-17, Rear ABS Sensor.> and Front: <Ref. to ABS-20, Front Tone Wheel.> Rear: <Ref. to ABS-21, Rear Tone Wheel.>	Go to step 7.

DIAGNOSTICS CHART WITH DIAGNOSIS CONNECTOR

ABS (DIAGNOSTICS)

Step	Check	Yes	No	
7	CHECK TONE WHEEL RUNOUT. Measure tone wheel runout.	Is the runout less than 0.05 mm (0.0020 in)?	Go to step 8.	Replace tone wheel. Front: <Ref. to ABS-20, Front Tone Wheel.> Rear: <Ref. to ABS-21, Rear Tone Wheel.>
8	CHECK RESISTANCE OF ABS SENSOR. 1) Turn ignition switch OFF. 2) Disconnect connector from ABS sensor. 3) Measure resistance between ABS sensor connector terminals. Terminal Front RH No. 1 — No. 2: Front LH No. 1 — No. 2: Rear RH No. 1 — No. 2: Rear LH No. 1 — No. 2:	Is the resistance between 1 and 1.5 kΩ?	Go to step 9.	Replace ABS sensor. Front: <Ref. to ABS-14, Front ABS Sensor.> Rear: <Ref. to ABS-17, Rear ABS Sensor.>
9	CHECK GROUND SHORT OF ABS SENSOR. Measure resistance between ABS sensor and chassis ground. Terminal Front RH No. 1 — Chassis ground: Front LH No. 1 — Chassis ground: Rear RH No. 1 — Chassis ground: Rear LH No. 1 — Chassis ground:	Is the resistance more than 1 MΩ?	Go to step 10.	Replace ABS sensor. Front: <Ref. to ABS-14, Front ABS Sensor.> Rear: <Ref. to ABS-17, Rear ABS Sensor.>
10	CHECK HARNESS/CONNECTOR BETWEEN ABSCM&H/U AND ABS SENSOR. 1) Connect connector to ABS sensor. 2) Disconnect connector from ABSCM&H/U. 3) Measure resistance at ABSCM&H/U connector terminals. Connector & terminal Trouble code 22 / (F49) No. 11 — No. 12: Trouble code 24 / (F49) No. 9 — No. 10: Trouble code 26 / (F49) No. 14 — No. 15: Trouble code 28 / (F49) No. 7 — No. 8:	Is the resistance between 1 and 1.5 kΩ?	Go to step 11.	Repair harness/connector between ABSCM&H/U and ABS sensor.
11	CHECK GROUND SHORT OF HARNESS. Measure resistance between ABSCM&H/U connector and chassis ground. Connector & terminal Trouble code 22 / (F49) No. 11 — Chassis ground: Trouble code 24 / (F49) No. 9 — Chassis ground: Trouble code 26 / (F49) No. 14 — Chassis ground: Trouble code 28 / (F49) No. 7 — Chassis ground:	Is the resistance more than 1 MΩ?	Go to step 12.	Repair harness/connector between ABSCM&H/U and ABS sensor.
12	CHECK GROUND CIRCUIT OF ABSCM&H/U. Measure resistance between ABSCM&H/U and chassis ground. Connector & terminal (F49) No. 23 — GND:	Is the resistance less than 0.5 Ω?	Go to step 13.	Repair ABSCM&H/U ground harness.
13	CHECK POOR CONTACT IN CONNECTORS.	Is there poor contact in connectors between ABSCM&H/U and ABS sensor?	Repair connector.	Go to step 14.

DIAGNOSTICS CHART WITH DIAGNOSIS CONNECTOR

ABS (DIAGNOSTICS)

Step	Check	Yes	No
14	CHECK SOURCES OF SIGNAL NOISE.	Go to step 15 .	Properly install the car telephone or the wireless transmitter.
15	CHECK SOURCES OF SIGNAL NOISE.	Install the noise sources apart from the sensor harness.	Go to step 16 .
16	CHECK SHIELD CIRCUIT. 1)Connect all connectors. 2)Measure resistance between shield connector and chassis ground. Connector & terminal <i>Trouble code 26 / (B200) No. 11 — Chassis ground:</i> <i>Trouble code 28 / RHD: (B200) No. 1 — Chassis ground:</i> <i>Trouble code 28 / LHD: (B200) No. 3 — Chassis ground:</i> NOTE: For the Trouble code 22 and 24 : Go to step 17 .	Is the resistance less than 0.5 Ω ?	Go to step 17 . Repair shield harness.
17	CHECK ABSCM&H/U. 1)Connect all connectors. 2)Erase the memory. 3)Perform inspection mode. 4)Read out the trouble code.	Is the same trouble code as in the current diagnosis still being output?	Replace ABSCM&H/U. <Ref. to ABS-7, ABS Control Module and Hydraulic Control Unit (ABSCM&H/U).> Go to step 18 .
18	CHECK ANY OTHER TROUBLE CODES APPEARANCE.	Are other trouble codes being output?	Proceed with the diagnosis corresponding to the trouble code. A temporary noise interference.

DIAGNOSTICS CHART WITH DIAGNOSIS CONNECTOR

ABS (DIAGNOSTICS)

L: TROUBLE CODE 29

— ABNORMAL ABS SENSOR SIGNAL (ANY ONE OF FOUR) —

DIAGNOSIS:

- Faulty ABS sensor signal (noise, irregular signal, etc.)
- Faulty tone wheel
- Wheels turning freely for a long time

TROUBLE SYMPTOM:

- ABS does not operate.

WIRING DIAGRAM: LHD MODEL

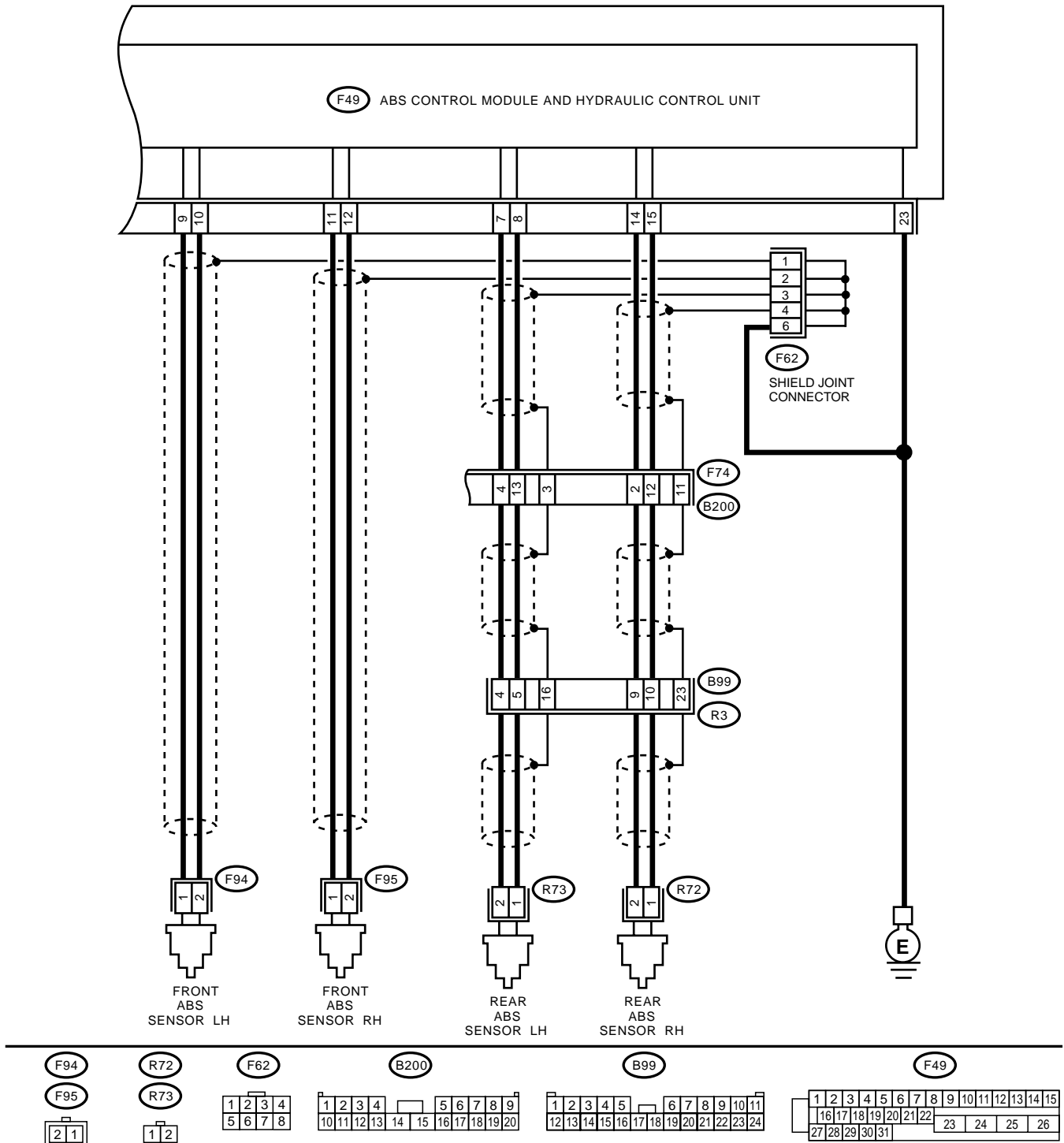

BR0037

DIAGNOSTICS CHART WITH DIAGNOSIS CONNECTOR

ABS (DIAGNOSTICS)

WIRING DIAGRAM: RHD MODEL

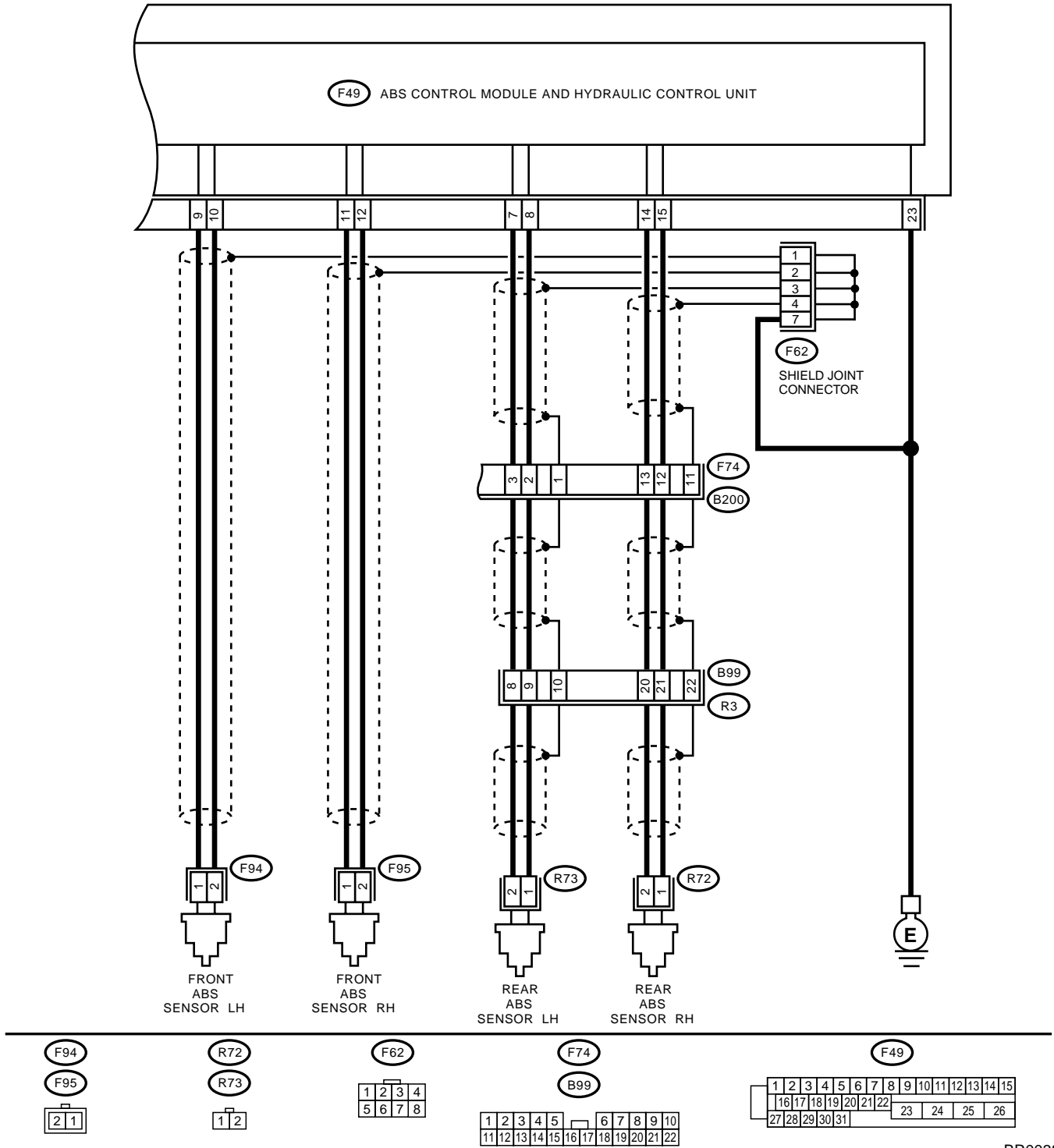

BR0038

DIAGNOSTICS CHART WITH DIAGNOSIS CONNECTOR

ABS (DIAGNOSTICS)

Step	Check	Yes	No
1	CHECK IF THE WHEELS HAVE TURNED FREELY FOR A LONG TIME.	Check if the wheels have been turned freely for more than one minute, such as when the vehicle is jacked-up, under full-lock cornering or when tire is not in contact with road surface.	The ABS is normal. Erase the trouble code. NOTE: When the wheels turn freely for a long time, such as when the vehicle is towed or jacked-up, or when steering wheel is continuously turned all the way, this trouble code may sometimes occur.
2	CHECK TIRE SPECIFICATIONS. Turn ignition switch to OFF.	Are the tire specifications correct?	Go to step 3. Replace tire.
3	CHECK WEAR OF TIRE.	Is the tire worn excessively?	Replace tire. Go to step 4.
4	CHECK TIRE PRESSURE.	Is the tire pressure correct?	Go to step 5. Adjust tire pressure.
5	CHECK INSTALLATION OF ABS SENSOR. <i>Tightening torque:</i> 32±10 N·m (3.3±1.0 kgf·m, 24±7 ft·lb)	Are the ABS sensor installation bolts tightened securely?	Go to step 6. Tighten ABS sensor installation bolts securely.
6	CHECK ABS SENSOR GAP. Measure tone wheel to ABS sensor piece gap over entire perimeter of the wheel. Specifications <i>Front wheel</i> 0.3 — 0.8 mm (0.012 — 0.031 in) <i>Rear wheel</i> 0.7 — 1.2 mm (0.028 — 0.047 in)	Is the gap within the specifications?	Go to step 7. Adjust the gap. NOTE: Adjust the gap using spacer (Part No. 26755AA000). If spacers cannot correct the gap, replace worn sensor or worn tone wheel.
7	PREPARE OSCILLOSCOPE.	Is an oscilloscope available?	Go to step 8. Go to step 9.
8	CHECK ABS SENSOR SIGNAL. 1) Raise all four wheels of ground. 2) Turn ignition switch OFF. 3) Connect the oscilloscope to the connector. 4) Turn ignition switch ON. 5) Rotate wheels and measure voltage at specified frequency. <Ref. to ABS-17, WAVEFORM, Control Module I/O Signal.> NOTE: When this inspection is completed, the ABS/SCM&H/U sometimes stores the trouble code 29. Connector & terminal <i>Front RH</i> (F95) No. 1 (+) — No. 2 (-): <i>Front LH</i> (F94) No. 1 (+) — No. 2 (-): <i>Rear RH</i> LHD: (B99) No. 9 (+) — No. 10 (-): RHD: (B99) No. 20 (+) — No. 21 (-): <i>Rear LH</i> LHD: (B99) No. 4 (+) — No. 5 (-): RHD: (B99) No. 8 (+) — No. 9 (-):	Is oscilloscope pattern smooth, as shown in figure?	Go to step 12. Go to step 9.

DIAGNOSTICS CHART WITH DIAGNOSIS CONNECTOR

ABS (DIAGNOSTICS)

Step	Check	Yes	No
9 CHECK CONTAMINATION OF ABS SENSOR OR TONE WHEEL. Remove disc rotor from hub.	Is the ABS sensor piece or the tone wheel contaminated by dirt or other foreign matter?	Thoroughly remove dirt or other foreign matter.	Go to step 10 .
10 CHECK DAMAGE OF ABS SENSOR OR TONE WHEEL.	Are there broken or damaged teeth in the ABS sensor piece or the tone wheel?	Replace ABS sensor or tone wheel. Front: <Ref. to ABS-14, Front ABS Sensor.> Rear: <Ref. to ABS-17, Rear ABS Sensor.> and Front: <Ref. to ABS-20, Front Tone Wheel.> Rear: <Ref. to ABS-21, Rear Tone Wheel.>	Go to step 11 .
11 CHECK TONE WHEEL RUNOUT. Measure tone wheel runout.	Is the runout less than 0.05 mm (0.0020 in)?	Go to step 12 .	Replace tone wheel. Front: <Ref. to ABS-20, Front Tone Wheel.> Rear: <Ref. to ABS-21, Rear Tone Wheel.>
12 CHECK ABSCM&H/U. 1)Turn ignition switch to OFF. 2)Connect all connectors. 3)Erase the memory. 4)Perform inspection mode. 5)Read out the trouble code.	Is the same trouble code as in the current diagnosis still being output?	Replace ABSCM&H/U. <Ref. to ABS-7, ABS Control Module and Hydraulic Control Unit (ABSCM&H/U).>	Go to step 13 .
13 CHECK ANY OTHER TROUBLE CODES APPEARANCE.	Are other trouble codes being output?	Proceed with the diagnosis corresponding to the trouble code.	A temporary poor contact.

DIAGNOSTICS CHART WITH DIAGNOSIS CONNECTOR

ABS (DIAGNOSTICS)

M: TROUBLE CODE 31

**— ABNORMAL INLET SOLENOID VALVE CIRCUIT(S) IN ABSCM&H/U
(FRONT RH) —**

NOTE:

For the diagnostic procedure, refer to TROUBLE CODE 37. <Ref. to ABS-59, TROUBLE CODE 37 — ABNORMAL INLET SOLENOID VALVE CIRCUIT(S) IN ABSCM&H/U (REAR LH) —, Diagnostics Chart with Diagnosis Connector.>

N: TROUBLE CODE 33

**— ABNORMAL INLET SOLENOID VALVE CIRCUIT(S) IN ABSCM&H/U
(FRONT LH) —**

NOTE:

For the diagnostic procedure, refer to TROUBLE CODE 37. <Ref. to ABS-59, TROUBLE CODE 37 — ABNORMAL INLET SOLENOID VALVE CIRCUIT(S) IN ABSCM&H/U (REAR LH) —, Diagnostics Chart with Diagnosis Connector.>

O: TROUBLE CODE 35

**— ABNORMAL INLET SOLENOID VALVE CIRCUIT(S) IN ABSCM&H/U
(REAR RH) —**

NOTE:

For the diagnostic procedure, refer to TROUBLE CODE 37. <Ref. to ABS-59, TROUBLE CODE 37 — ABNORMAL INLET SOLENOID VALVE CIRCUIT(S) IN ABSCM&H/U (REAR LH) —, Diagnostics Chart with Diagnosis Connector.>

P: TROUBLE CODE 37

**— ABNORMAL INLET SOLENOID VALVE CIRCUIT(S) IN ABSCM&H/U
(REAR LH) —**

DIAGNOSIS:

- Faulty harness/connector
- Faulty inlet solenoid valve in ABSCM&H/U

TROUBLE SYMPTOM:

- ABS does not operate.

DIAGNOSTICS CHART WITH DIAGNOSIS CONNECTOR

ABS (DIAGNOSTICS)

WIRING DIAGRAM:

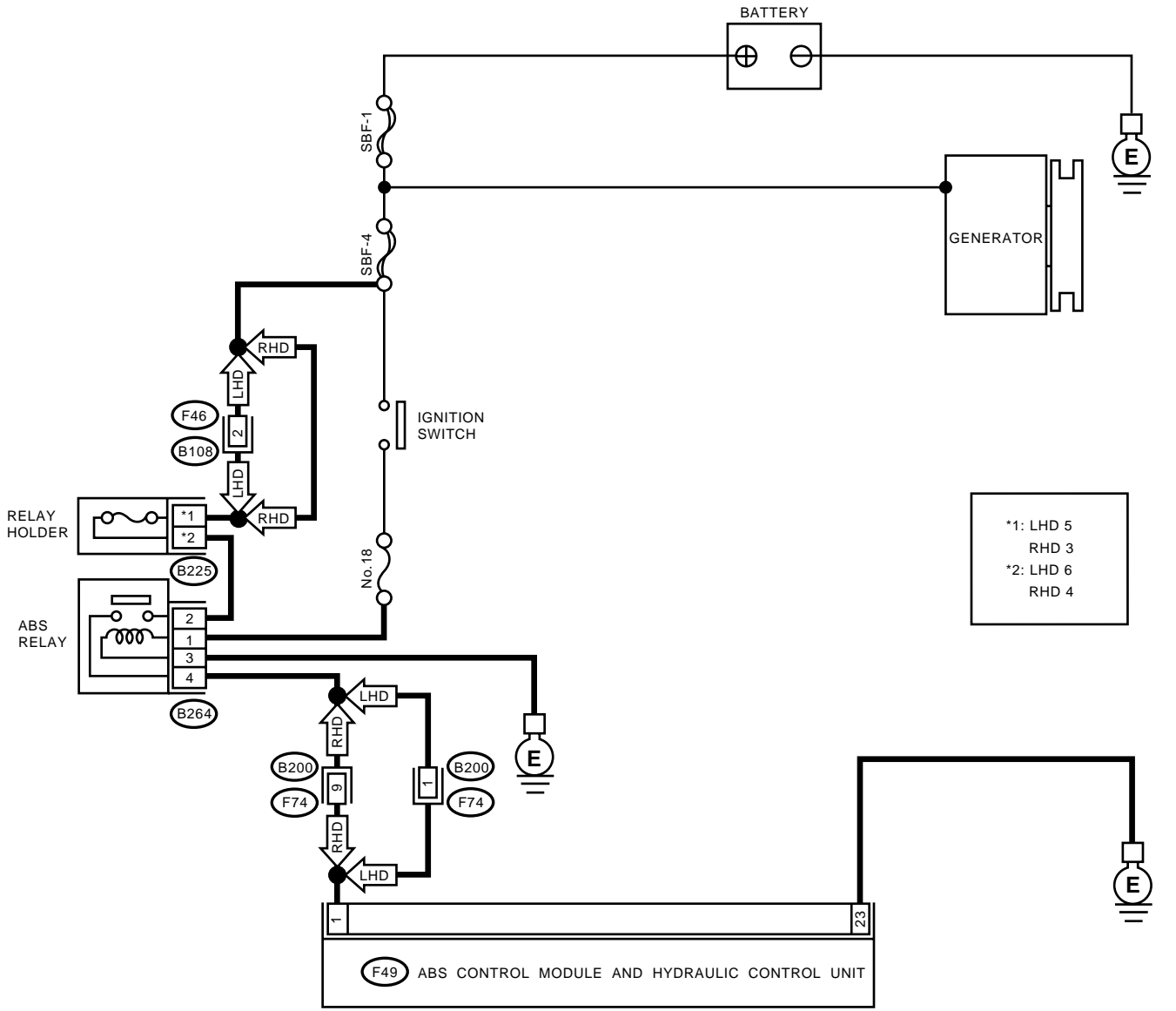

*1: LHD 5
RHD 3
*2: LHD 6
RHD 4

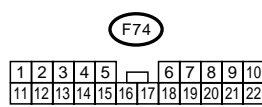
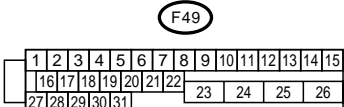
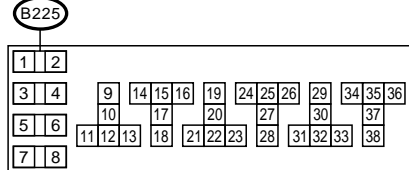
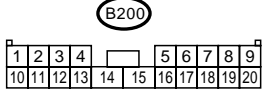

BR0039

DIAGNOSTICS CHART WITH DIAGNOSIS CONNECTOR

ABS (DIAGNOSTICS)

Step	Check	Yes	No
1 CHECK INPUT VOLTAGE OF RELAY HOLDER. 1) Turn ignition switch to OFF. 2) Remove fuse. 3) Measure voltage between ABS relay connector and chassis ground. Connector & terminal <i>LHD model</i> (B225) No. 5 (+) — Chassis ground (-): <i>RHD model</i> (B225) No. 3 (+) — Chassis ground (-):	Is the voltage more than 10 V?	Go to step 2.	Repair open circuit in harness between battery and Relay holder connector.
2 CHECK RELAY HOLDER.	Is the fuse blown out?	Replace fuse.	Go to step 3.
3 CHECK INPUT VOLTAGE OF ABS RELAY. 1) Install fuse. 2) Remove ABS relay. 3) Turn ignition switch to ON. 4) Measure voltage between ABS relay connector and chassis ground. Connector & terminal (B264) No. 2 (+) — Chassis ground (-):	Is the voltage more than 10 V?	Go to step 4.	Repair open circuit in harness between battery and Relay holder connector.
4 CHECK INPUT VOLTAGE OF ABS RELAY. Measure voltage between ABS relay connector and chassis ground. Connector & terminal (B264) No. 1 (+) — Chassis ground (-):	Is the voltage more than 10 V?	Go to step 5.	Repair harness connector between battery, ignition switch and ABS relay.
5 CHECK GROUND CIRCUIT OF ABS RELAY. 1) Turn ignition switch to OFF. 2) Measure resistance between ABS relay connector and chassis ground. Connector & terminal (B264) No. 3 (+) — Chassis ground:	Is the resistance less than 5 Ω ?	Go to step 6.	Repair open circuit between ABS relay and chassis ground.
6 CHECK ABS RELAY. 1) Connect battery to ABS relay terminal No. 1 and 3. 2) Measure resistance between ABS relay terminals.	Is the resistance less than 10 Ω ?	Go to step 7.	Replace ABS relay.
7 CHECK INPUT VOLTAGE OF ABSCM&H/U. 1) Disconnect connector from ABSCM&H/U. 2) Run the engine at idle. 3) Measure voltage between ABSCM&H/U connector and chassis ground. Connector & terminal (F49) No. 1 (+) — Chassis ground (-):	Is the voltage between 10 and 15 V?	Go to step 8.	Repair harness connector between ABS relay and ABSCM&H/U.
8 CHECK GROUND CIRCUIT OF ABSCM&H/U. 1) Turn ignition switch to OFF. 2) Measure resistance between ABSCM&H/U connector and chassis ground. Connector & terminal (F49) No. 23 — Chassis ground:	Is the resistance less than 0.5 Ω ?	Go to step 9.	Repair ABSCM&H/U ground harness.
9 CHECK POOR CONTACT IN CONNECTORS.	Is there poor contact in connectors between generator, battery and ABSCM&H/U?	Repair connector.	Go to step 10.
10 CHECK ABSCM&H/U. 1) Connect all connectors. 2) Erase the memory. 3) Perform inspection mode. 4) Read out the trouble code.	Is the same trouble code as in the current diagnosis still being output?	Replace ABSCM&H/U. <Ref. to ABS-7, ABS Control Module and Hydraulic Control Unit (ABSCM&H/U).>	Go to step 11.

DIAGNOSTICS CHART WITH DIAGNOSIS CONNECTOR

ABS (DIAGNOSTICS)

	Step	Check	Yes	No
11	CHECK ANY OTHER TROUBLE CODES APPEARANCE.	Are other trouble codes being output?	Proceed with the diagnosis corresponding to the trouble code.	A temporary poor contact.

Q: TROUBLE CODE 32
— ABNORMAL OUTLET SOLENOID VALVE CIRCUIT(S) IN ABSCM&H/U
(FRONT RH) —

NOTE:

For the diagnostic procedure, refer to TROUBLE CODE 38. <Ref. to ABS-65, TROUBLE CODE 38 — ABNORMAL OUTLET SOLENOID VALVE CIRCUIT(S) IN ABSCM&H/U (REAR LH) —, Diagnostics Chart with Diagnosis Connector.>

R: TROUBLE CODE 34
— ABNORMAL OUTLET SOLENOID VALVE CIRCUIT(S) IN ABSCM&H/U
(FRONT LH) —

NOTE:

For the diagnostic procedure, refer to TROUBLE CODE 38. <Ref. to ABS-65, TROUBLE CODE 38 — ABNORMAL OUTLET SOLENOID VALVE CIRCUIT(S) IN ABSCM&H/U (REAR LH) —, Diagnostics Chart with Diagnosis Connector.>

S: TROUBLE CODE 36
— ABNORMAL OUTLET SOLENOID VALVE CIRCUIT(S) IN ABSCM&H/U
(REAR RH) —

NOTE:

For the diagnostic procedure, refer to TROUBLE CODE 38. <Ref. to ABS-65, TROUBLE CODE 38 — ABNORMAL OUTLET SOLENOID VALVE CIRCUIT(S) IN ABSCM&H/U (REAR LH) —, Diagnostics Chart with Diagnosis Connector.>

DIAGNOSTICS CHART WITH DIAGNOSIS CONNECTOR

ABS (DIAGNOSTICS)

T: TROUBLE CODE 38

**— ABNORMAL OUTLET SOLENOID VALVE CIRCUIT(S) IN ABSCM&H/U
(REAR LH) —**

DIAGNOSIS:

- Faulty harness/connector
- Faulty outlet solenoid valve in ABSCM&H/U

TROUBLE SYMPTOM:

- ABS does not operate.

DIAGNOSTICS CHART WITH DIAGNOSIS CONNECTOR

ABS (DIAGNOSTICS)

WIRING DIAGRAM:

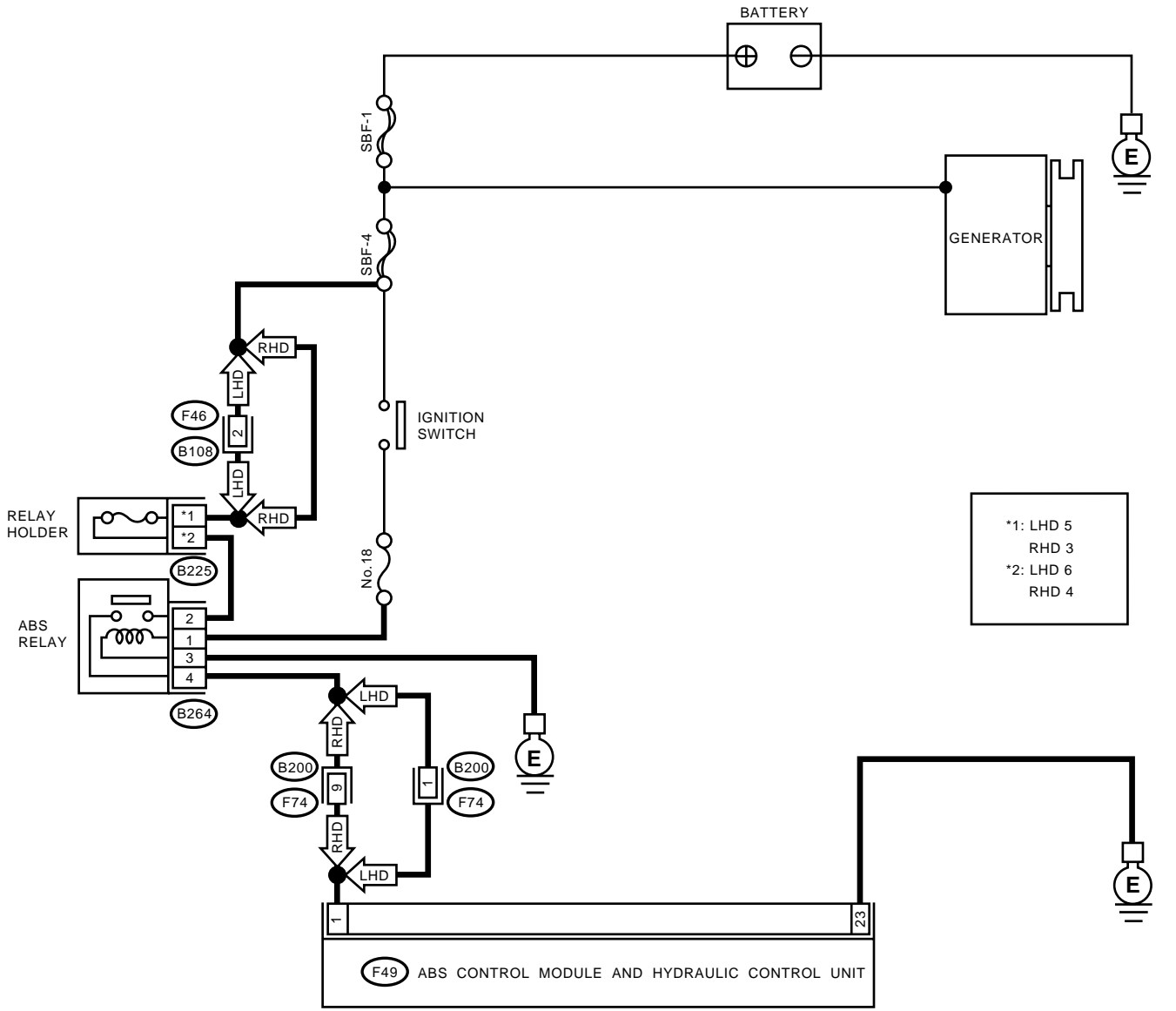

*1: LHD 5
RHD 3
*2: LHD 6
RHD 4

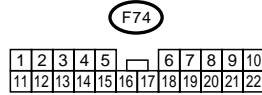
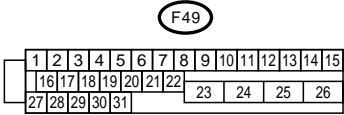
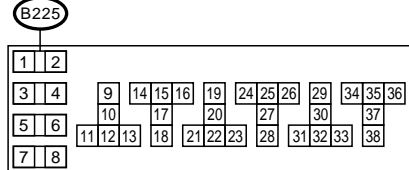
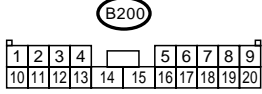

BR0039

DIAGNOSTICS CHART WITH DIAGNOSIS CONNECTOR

ABS (DIAGNOSTICS)

Step	Check	Yes	No
1 CHECK INPUT VOLTAGE OF RELAY HOLDER. 1) Turn ignition switch to OFF. 2) Remove fuse. 3) Measure voltage between ABS relay connector and chassis ground. Connector & terminal <i>LHD model</i> (B225) No. 5 (+) — Chassis ground (-): <i>RHD model</i> (B225) No. 3 (+) — Chassis ground (-):	Is the voltage more than 10 V?	Go to step 2.	Repair open circuit in harness between battery and Relay holder connector.
2 CHECK RELAY HOLDER.	Is the fuse blown out?	Replace fuse.	Go to step 3.
3 CHECK INPUT VOLTAGE OF ABS RELAY. 1) Install fuse. 2) Remove ABS relay. 3) Turn ignition switch to ON. 4) Measure voltage between ABS relay connector and chassis ground. Connector & terminal (B264) No. 2 (+) — Chassis ground (-):	Is the voltage more than 10 V?	Go to step 4.	Repair open circuit in harness between battery and Relay holder connector.
4 CHECK INPUT VOLTAGE OF ABS RELAY. Measure voltage between ABS relay connector and chassis ground. Connector & terminal (B264) No. 1 (+) — Chassis ground (-):	Is the voltage more than 10 V?	Go to step 5.	Repair harness connector between battery, ignition switch and ABS relay.
5 CHECK GROUND CIRCUIT OF ABS RELAY. 1) Turn ignition switch to OFF. 2) Measure resistance between ABS relay connector and chassis ground. Connector & terminal (B264) No. 3 (+) — Chassis ground:	Is the resistance less than 5 Ω ?	Go to step 6.	Repair open circuit between ABS relay and chassis ground.
6 CHECK ABS RELAY. 1) Connect battery to ABS relay terminal No. 1 and 3. 2) Measure resistance between ABS relay terminals.	Is the resistance less than 10 Ω ?	Go to step 7.	Replace ABS relay.
7 CHECK INPUT VOLTAGE OF ABSCM&H/U. 1) Disconnect connector from ABSCM&H/U. 2) Run the engine at idle. 3) Measure voltage between ABSCM&H/U connector and chassis ground. Connector & terminal (F49) No. 1 (+) — Chassis ground (-):	Is the voltage between 10 and 15 V?	Go to step 8.	Repair harness connector between battery, ignition switch and ABSCM&H/U.
8 CHECK GROUND CIRCUIT OF ABSCM&H/U. 1) Turn ignition switch to OFF. 2) Measure resistance between ABSCM&H/U connector and chassis ground. Connector & terminal (F49) No. 23 — Chassis ground:	Is the resistance less than 0.5 Ω ?	Go to step 9.	Repair ABSCM&H/U ground harness.
9 CHECK POOR CONTACT IN CONNECTORS.	Is there poor contact in connectors between generator, battery and ABSCM&H/U?	Repair connector.	Go to step 10.
10 CHECK ABSCM&H/U. 1) Connect all connectors. 2) Erase the memory. 3) Perform inspection mode. 4) Read out the trouble code.	Is the same trouble code as in the current diagnosis still being output?	Replace ABSCM&H/U. <Ref. to ABS-7, ABS Control Module and Hydraulic Control Unit (ABSCM&H/U).>	Go to step 11.

DIAGNOSTICS CHART WITH DIAGNOSIS CONNECTOR

ABS (DIAGNOSTICS)

	Step	Check	Yes	No
11	CHECK ANY OTHER TROUBLE CODES APPEARANCE.	Are other trouble codes being output?	Proceed with the diagnosis corresponding to the trouble code.	A temporary poor contact.

DIAGNOSTICS CHART WITH DIAGNOSIS CONNECTOR

ABS (DIAGNOSTICS)

DIAGNOSTICS CHART WITH DIAGNOSIS CONNECTOR

ABS (DIAGNOSTICS)

U: TROUBLE CODE 41 — ABNORMAL ABS CONTROL MODULE —

DIAGNOSIS:

- Faulty ABSCM&H/U.

TROUBLE SYMPTOM:

- ABS does not operate.

WIRING DIAGRAM:

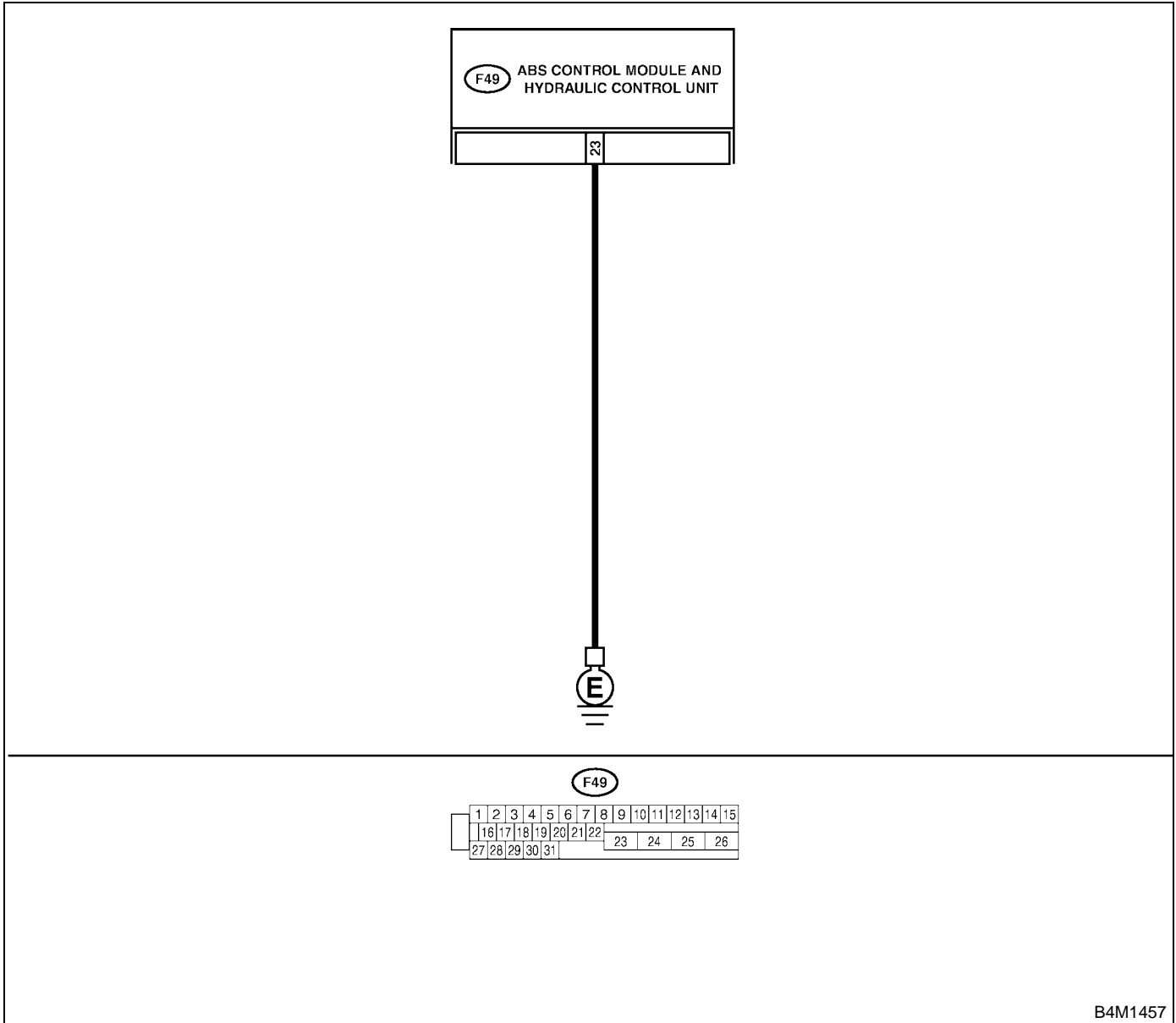

B4M1457

DIAGNOSTICS CHART WITH DIAGNOSIS CONNECTOR

ABS (DIAGNOSTICS)

Step	Check	Yes	No
1 CHECK GROUND CIRCUIT OF ABSCM&H/U. 1) Turn ignition switch to OFF. 2) Disconnect connector from ABSCM&H/U. 3) Measure resistance between ABSCM&H/U and chassis ground. <i>Connector & terminal (F49) No. 23 — Chassis ground:</i>	Is the resistance less than 0.5 Ω ?	Go to step 2.	Repair ABSCM&H/U ground harness.
2 CHECK POOR CONTACT IN CONNECTORS.	Is there poor contact in connectors between battery, ignition switch and ABSCM&H/U?	Repair connector.	Go to step 3.
3 CHECK SOURCES OF SIGNAL NOISE.	Is the car telephone or the wireless transmitter properly installed?	Go to step 4.	Properly install the car telephone or the wireless transmitter.
4 CHECK SOURCES OF SIGNAL NOISE.	Are noise sources (such as an antenna) installed near the sensor harness?	Install the noise sources apart from the sensor harness.	Go to step 5.
5 CHECK ABSCM&H/U. 1) Connect all connectors. 2) Erase the memory. 3) Perform inspection mode. 4) Read out the trouble code.	Is the same trouble code as in the current diagnosis still being output?	Replace ABSCM&H/U. <Ref. to ABS-7, ABS Control Module and Hydraulic Control Unit (ABSCM&H/U).>	Go to step 6.
6 CHECK ANY OTHER TROUBLE CODES APPEARANCE.	Are other trouble codes being output?	Proceed with the diagnosis corresponding to the trouble code.	A temporary poor contact.

DIAGNOSTICS CHART WITH DIAGNOSIS CONNECTOR

ABS (DIAGNOSTICS)

V: TROUBLE CODE 42 — SOURCE VOLTAGE IS ABNORMAL. —

DIAGNOSIS:

- Power source voltage of the ABSCM&H/U is low or high.

TROUBLE SYMPTOM:

- ABS does not operate.

WIRING DIAGRAM:

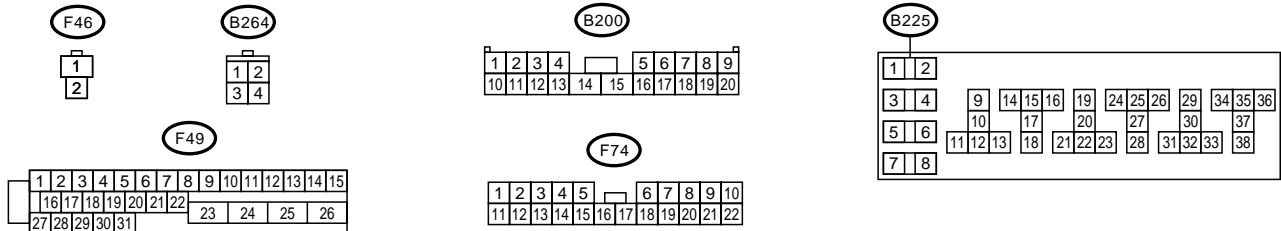
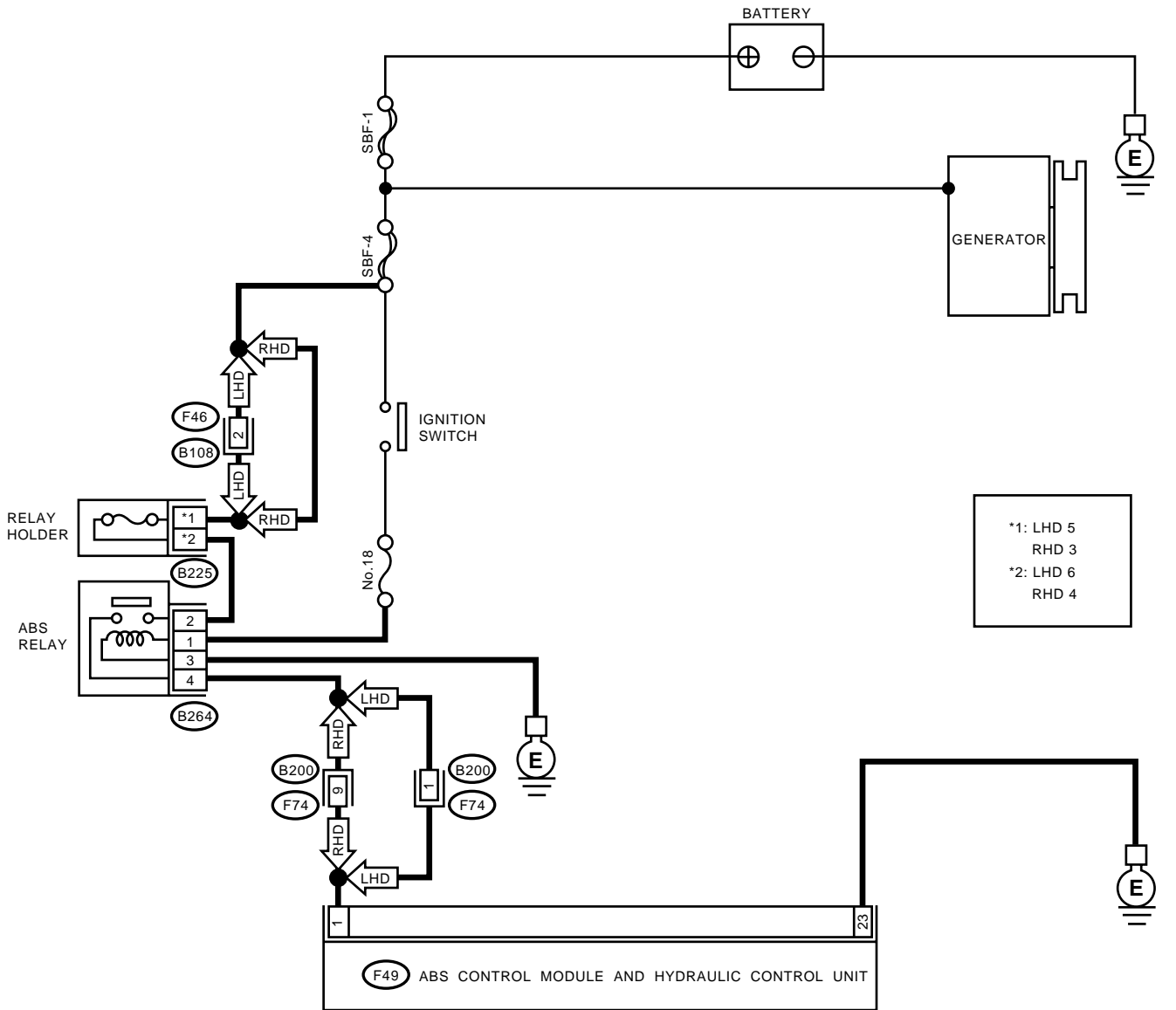

BR0039

DIAGNOSTICS CHART WITH DIAGNOSIS CONNECTOR

ABS (DIAGNOSTICS)

Step	Check	Yes	No
1 CHECK GENERATOR. 1)Start engine. 2)Idling after warm-up. 3)Measure voltage between generator B terminal and chassis ground. <i>Terminal</i> <i>Generator B terminal — Chassis ground:</i>	Is the voltage between 10 and 17 V?	Go to step 2.	Repair generator. <Ref. to SC-12, Generator.>
2 CHECK BATTERY TERMINAL. Turn ignition switch to OFF.	Are the positive and negative battery terminals tightly clamped?	Go to step 3.	Tighten the clamp of terminal.
3 CHECK INPUT VOLTAGE OF RELAY HOLDER. 1)Turn ignition switch to OFF. 2)Remove fuse. 3)Measure voltage between ABS relay connector and chassis ground. <i>Connector & terminal</i> <i>LHD model</i> <i>(B225) No. 5 (+) — Chassis ground (-):</i> <i>RHD model</i> <i>(B225) No. 3 (+) — Chassis ground (-):</i>	Is the voltage more than 10 V?	Go to step 4.	Repair open circuit in harness between battery and Relay holder connector.
4 CHECK RELAY HOLDER.	Is the fuse blown out?	Replace fuse.	Go to step 5.
5 CHECK INPUT VOLTAGE OF ABS RELAY. 1)Install fuse. 2)Remove ABS relay. 3)Turn ignition switch to ON. 4)Measure voltage between ABS relay connector and chassis ground. <i>Connector & terminal</i> <i>(B264) No. 2 (+) — Chassis ground (-):</i>	Is the voltage more than 10 V?	Go to step 6.	Repair open circuit in harness between battery and Relay holder connector.
6 CHECK INPUT VOLTAGE OF ABS RELAY. Measure voltage between ABS relay connector and chassis ground. <i>Connector & terminal</i> <i>(B264) No. 1 (+) — Chassis ground (-):</i>	Is the voltage more than 10 V?	Go to step 7.	Repair harness connector between battery, ignition switch and ABS relay.
7 CHECK GROUND CIRCUIT OF ABS RELAY. 1)Turn ignition switch to OFF. 2)Measure resistance between ABS relay connector and chassis ground. <i>Connector & terminal</i> <i>(B264) No. 3 (+) — Chassis ground:</i>	Is the resistance less than 5 Ω ?	Go to step 8.	Repair open circuit between ABS relay and chassis ground.
8 CHECK ABS RELAY. 1)Connect battery to ABS relay terminal No. 1 and 3. 2)Measure resistance between ABS relay terminals.	Is the resistance less than 10 Ω ?	Go to step 9.	Replace ABS relay.
9 CHECK INPUT VOLTAGE OF ABSCM&H/U. 1)Disconnect connector from ABSCM&H/U. 2)Run the engine at idle. 3)Measure voltage between ABSCM&H/U connector and chassis ground. <i>Connector & terminal</i> <i>(F49) No. 1 (+) — Chassis ground (-):</i>	Is the voltage between 10 and 17 V?	Go to step 10.	Repair harness connector between battery, ignition switch and ABSCM&H/U.
10 CHECK GROUND CIRCUIT OF ABSCM&H/U. 1)Turn ignition switch to OFF. 2)Measure resistance between ABSCM&H/U connector and chassis ground. <i>Connector & terminal</i> <i>(F49) No. 23 — Chassis ground:</i>	Is the resistance less than 0.5 Ω ?	Go to step 11.	Repair ABSCM&H/U ground harness.

DIAGNOSTICS CHART WITH DIAGNOSIS CONNECTOR

ABS (DIAGNOSTICS)

Step	Check	Yes	No
11 CHECK POOR CONTACT IN CONNECTORS.	Is there poor contact in connectors between generator, battery and ABSCM&H/U?	Repair connector.	Go to step 12 .
12 CHECK ABSCM&H/U. 1)Connect all connectors. 2)Erase the memory. 3)Perform inspection mode. 4)Read out the trouble code.	Is the same trouble code as in the current diagnosis still being output?	Replace ABSCM&H/U. <Ref. to ABS-7, ABS Control Module and Hydraulic Control Unit (ABSCM&H/U).>	Go to step 13 .
13 CHECK ANY OTHER TROUBLE CODES APPEARANCE.	Are other trouble codes being output?	Proceed with the diagnosis corresponding to the trouble code.	A temporary poor contact.

DIAGNOSTICS CHART WITH DIAGNOSIS CONNECTOR

ABS (DIAGNOSTICS)

DIAGNOSTICS CHART WITH DIAGNOSIS CONNECTOR

ABS (DIAGNOSTICS)

W: TROUBLE CODE 44

— A COMBINATION OF AT CONTROL ABNORMAL —

DIAGNOSIS:

- Combination of AT control faults

TROUBLE SYMPTOM:

- ABS does not operate.

WIRING DIAGRAM:

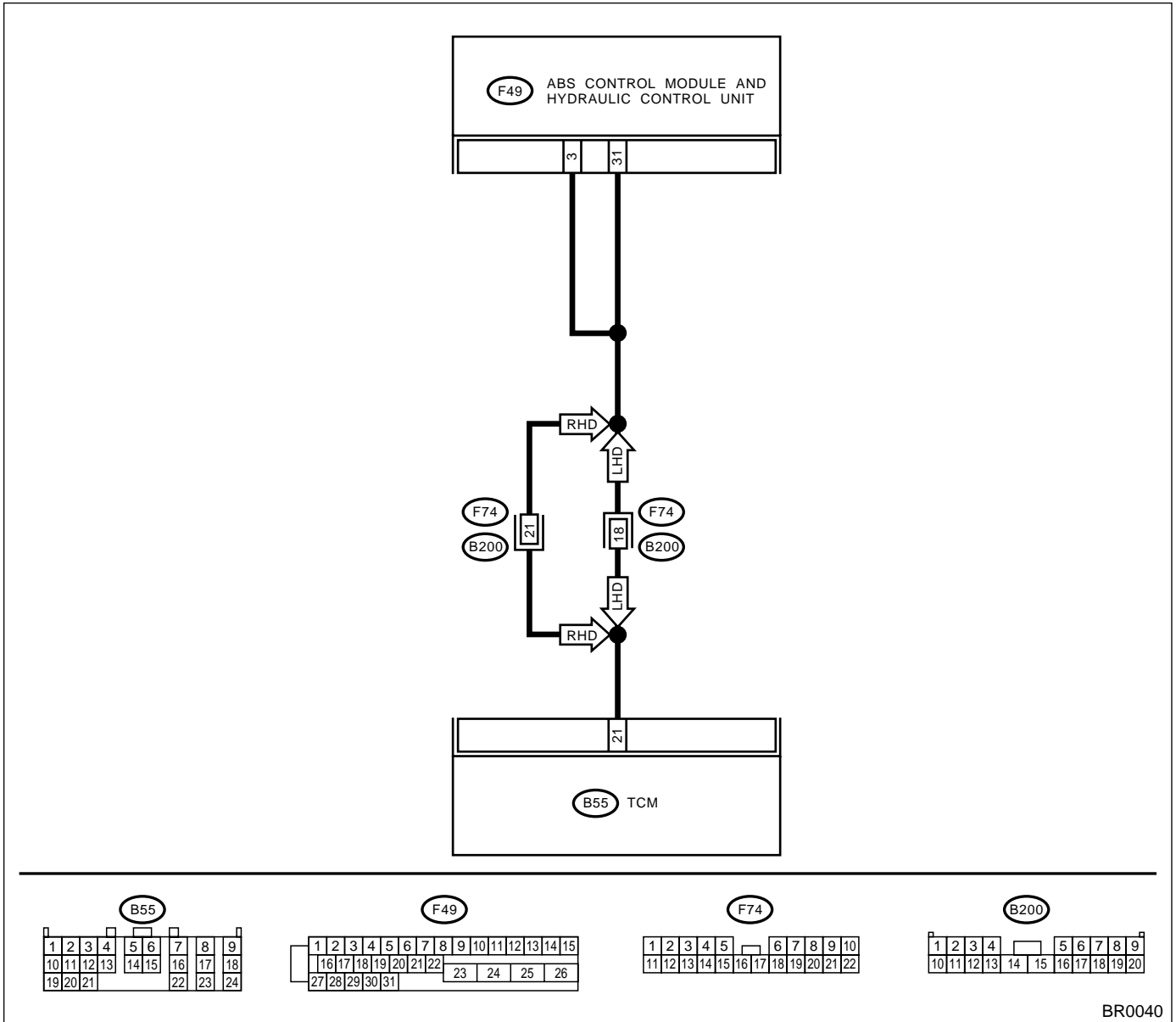

BR0040

DIAGNOSTICS CHART WITH DIAGNOSIS CONNECTOR

ABS (DIAGNOSTICS)

Step	Check	Yes	No
1 CHECK SPECIFICATIONS OF THE AB-SCM&H/U. Check specifications of the mark to the ABSCM&H/U. <i>CA: AT (FWD)</i> <i>CB: MT (FWD)</i> <i>CC: AT (AWD)</i> <i>CD: MT (AWD)</i>	Is an ABSCM&H/U for AT model installed on a MT model?	Replace ABSCM&H/U. <Ref. to ABS-7, ABS Control Module and Hydraulic Control Unit (ABSCM&H/U).>	Go to step 2.
2 CHECK GROUND SHORT OF HARNESS. 1)Turn ignition switch to OFF. 2)Disconnect two connectors from TCM. 3)Disconnect connector from ABSCM&H/U. 4)Measure resistance between ABSCM&H/U connector and chassis ground. <i>Connector & terminal (F49) No. 3 — Chassis ground:</i>	Is the resistance more than 1 MΩ?	Go to step 3.	Repair harness between TCM and ABSCM&H/U.
3 CHECK BATTERY SHORT OF HARNESS. Measure voltage between ABSCM&H/U connector and chassis ground. <i>Connector & terminal (F49) No. 3 (+) — Chassis ground (-):</i>	Is the voltage less than 1 V?	Go to step 4.	Repair harness between TCM and ABSCM&H/U.
4 CHECK BATTERY SHORT OF HARNESS. 1)Turn ignition switch to ON. 2)Measure voltage between ABSCM&H/U connector and chassis ground. <i>Connector & terminal (F49) No. 3 (+) — Chassis ground (-):</i>	Is the voltage less than 1 V?	Go to step 5.	Repair harness between TCM and ABSCM&H/U.
5 CHECK TCM. 1)Turn ignition switch to OFF. 2)Connect all connectors to TCM. 3)Turn ignition switch to ON. 4)Measure voltage between TCM connector terminal and chassis ground. <i>Connector & terminal (B55) No. 21 (+) — Chassis ground (-):</i>	Is the voltage between 10 and 15 V?	Go to step 7.	Go to step 6.
6 CHECK AT.	Is the AT functioning normally?	Replace TCM.	Repair AT.
7 CHECK OPEN CIRCUIT OF HARNESS. Measure voltage between ABSCM&H/U connector and chassis ground. <i>Connector & terminal (F49) No. 3 (+) — Chassis ground (-):</i> <i>(F49) No. 31 (+) — Chassis ground (-):</i>	Is the voltage between 10 and 15 V?	Go to step 8.	Repair harness/connector between TCM and ABSCM&H/U.
8 CHECK POOR CONTACT IN CONNECTORS.	Is there poor contact in connectors between TCM and ABSCM&H/U?	Repair connector.	Go to step 9.
9 CHECK ABSCM&H/U. 1)Turn ignition switch to OFF. 2)Connect all connectors. 3)Erase the memory. 4)Perform inspection mode. 5)Read out the trouble code.	Is the same trouble code as in the current diagnosis still being output?	Replace ABSCM&H/U. <Ref. to ABS-7, ABS Control Module and Hydraulic Control Unit (ABSCM&H/U).>	Go to step 10.
10 CHECK ANY OTHER TROUBLE CODES APPEARANCE.	Are other trouble codes being output?	Proceed with the diagnosis corresponding to the trouble code.	A temporary poor contact.

DIAGNOSTICS CHART WITH DIAGNOSIS CONNECTOR

ABS (DIAGNOSTICS)

X: TROUBLE CODE 51
— ABNORMAL VALVE RELAY —

DIAGNOSIS:

- Faulty valve relay

TROUBLE SYMPTOM:

- ABS does not operate.

DIAGNOSTICS CHART WITH DIAGNOSIS CONNECTOR

ABS (DIAGNOSTICS)

WIRING DIAGRAM:

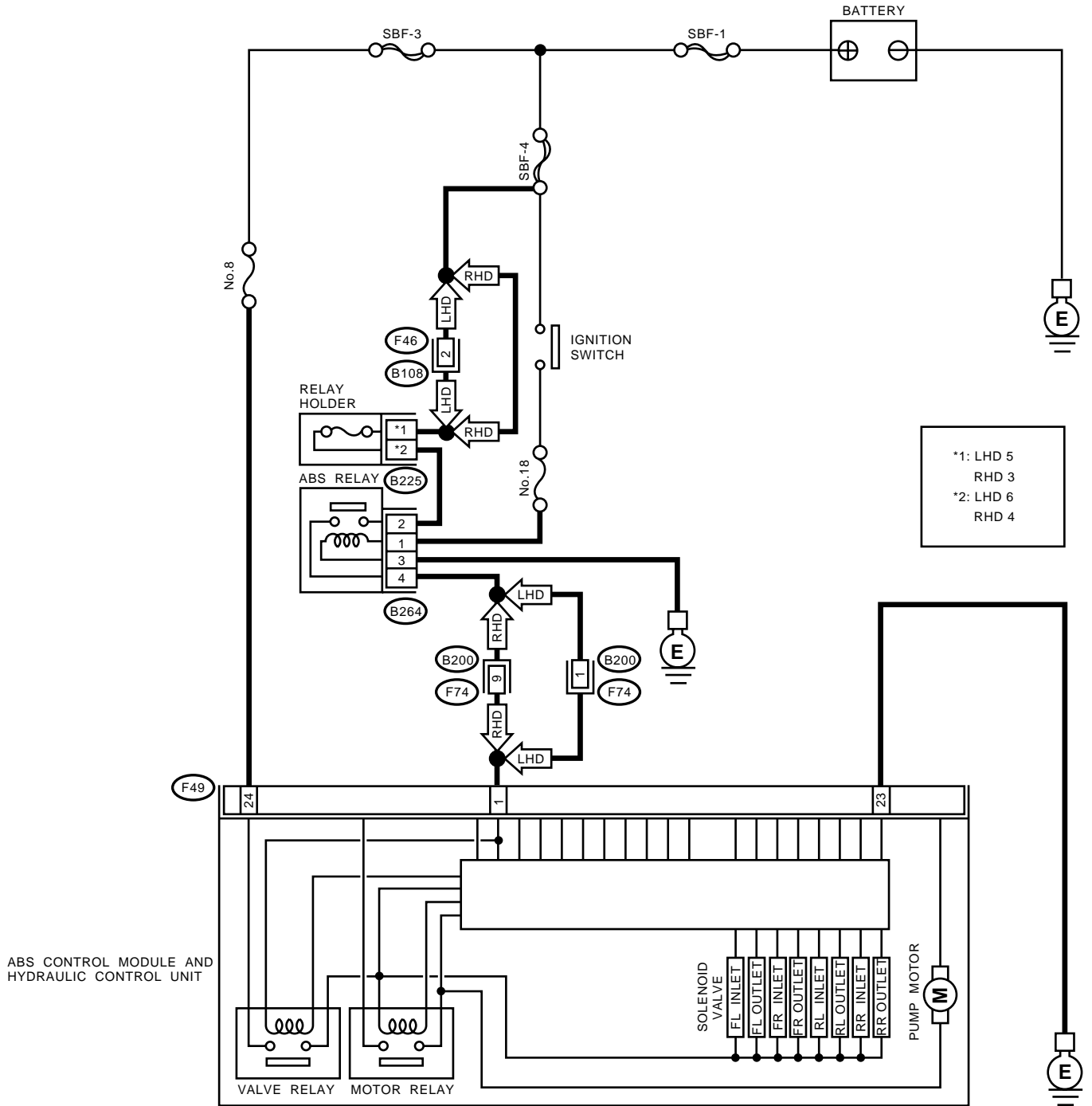

*1: LHD 5
RHD 3
*2: LHD 6
RHD 4

ABS CONTROL MODULE AND HYDRAULIC CONTROL UNIT

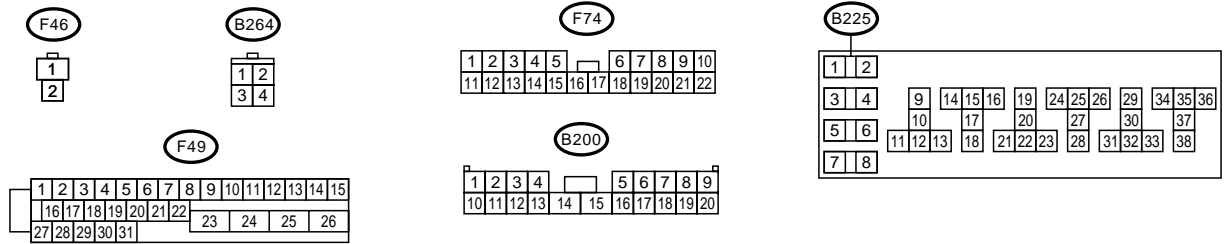

DIAGNOSTICS CHART WITH DIAGNOSIS CONNECTOR

ABS (DIAGNOSTICS)

Step	Check	Yes	No
1 CHECK INPUT VOLTAGE OF RELAY HOLDER. 1) Turn ignition switch to OFF. 2) Remove fuse. 3) Measure voltage between ABS relay connector and chassis ground. Connector & terminal <i>LHD model</i> (B225) No. 5 (+) — Chassis ground (-): <i>RHD model</i> (B225) No. 3 (+) — Chassis ground (-):	Is the voltage more than 10 V?	Go to step 2.	Repair open circuit in harness between battery and Relay holder connector.
2 CHECK RELAY HOLDER.	Is the fuse blown out?	Replace fuse.	Go to step 3.
3 CHECK INPUT VOLTAGE OF ABS RELAY. 1) Install fuse. 2) Remove ABS relay. 3) Turn ignition switch to ON. 4) Measure voltage between ABS relay connector and chassis ground. Connector & terminal (B264) No. 2 (+) — Chassis ground (-):	Is the voltage more than 10 V?	Go to step 4.	Repair open circuit in harness between battery and Relay holder connector.
4 CHECK INPUT VOLTAGE OF ABS RELAY. Measure voltage between ABS relay connector and chassis ground. Connector & terminal (B264) No. 1 (+) — Chassis ground (-):	Is the voltage more than 10 V?	Go to step 5.	Repair harness connector between battery, ignition switch and ABS relay.
5 CHECK GROUND CIRCUIT OF ABS RELAY. 1) Turn ignition switch to OFF. 2) Measure resistance between ABS relay connector and chassis ground. Connector & terminal (B264) No. 3 (+) — Chassis ground:	Is the resistance less than 5 Ω ?	Go to step 6.	Repair open circuit between ABS relay and chassis ground.
6 CHECK ABS RELAY. 1) Connect battery to ABS relay terminal No. 1 and 3. 2) Measure resistance between ABS relay terminals.	Is the resistance less than 10 Ω ?	Go to step 7.	Replace ABS relay.
7 CHECK INPUT VOLTAGE OF ABSCM&H/U. 1) Turn ignition switch to OFF. 2) Disconnect connector from ABSCM&H/U. 3) Run the engine at idle. 4) Measure voltage between ABSCM&H/U connector and chassis ground. Connector & terminal (F49) No. 1 (+) — Chassis ground (-): (F49) No. 24 (+) — Chassis ground (-):	Is the voltage between 10 and 15 V?	Go to step 8.	Repair harness connector between battery, ABS relay and ABSCM&H/U.
8 CHECK GROUND CIRCUIT OF ABSCM&H/U. 1) Turn ignition switch to OFF. 2) Measure resistance between ABSCM&H/U connector and chassis ground. Connector & terminal (F49) No. 23 — Chassis ground:	Is the resistance less than 0.5 Ω ?	Go to step 9.	Repair ABSCM&H/U ground harness.
9 CHECK VALVE RELAY IN ABSCM&H/U. Measure resistance between ABSCM&H/U and terminals. Terminals No. 23 (+) — No. 24 (-):	Is the resistance more than 1 M Ω ?	Go to step 10.	Replace ABSCM&H/U. <Ref. to ABS-7, ABS Control Module and Hydraulic Control Unit (ABSCM&H/U).>

DIAGNOSTICS CHART WITH DIAGNOSIS CONNECTOR

ABS (DIAGNOSTICS)

Step	Check	Yes	No	
10	CHECK POOR CONTACT IN CONNECTORS.	Is there poor contact in connectors between generator, battery and ABSCM&H/U?	Repair connector.	Go to step 11.
11	CHECK ABSCM&H/U. 1)Connect all connectors. 2)Erase the memory. 3)Perform inspection mode. 4)Read out the trouble code.	Is the same trouble code as in the current diagnosis still being output?	Replace ABSCM&H/U. <Ref. to ABS-7, ABS Control Module and Hydraulic Control Unit (ABSCM&H/U).>	Go to step 12.
12	CHECK ANY OTHER TROUBLE CODES APPEARANCE.	Are other trouble codes being output?	Proceed with the diagnosis corresponding to the trouble code.	A temporary poor contact.

Y: TROUBLE CODE 52

— ABNORMAL MOTOR AND/OR MOTOR RELAY —

DIAGNOSIS:

- Faulty motor
- Faulty motor relay
- Faulty harness connector

TROUBLE SYMPTOM:

- ABS does not operate.

DIAGNOSTICS CHART WITH DIAGNOSIS CONNECTOR

ABS (DIAGNOSTICS)

WIRING DIAGRAM:

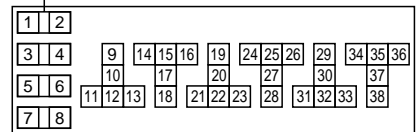
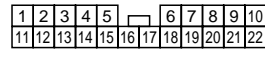
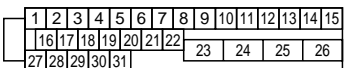
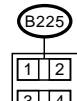
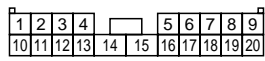
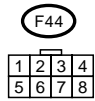
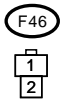
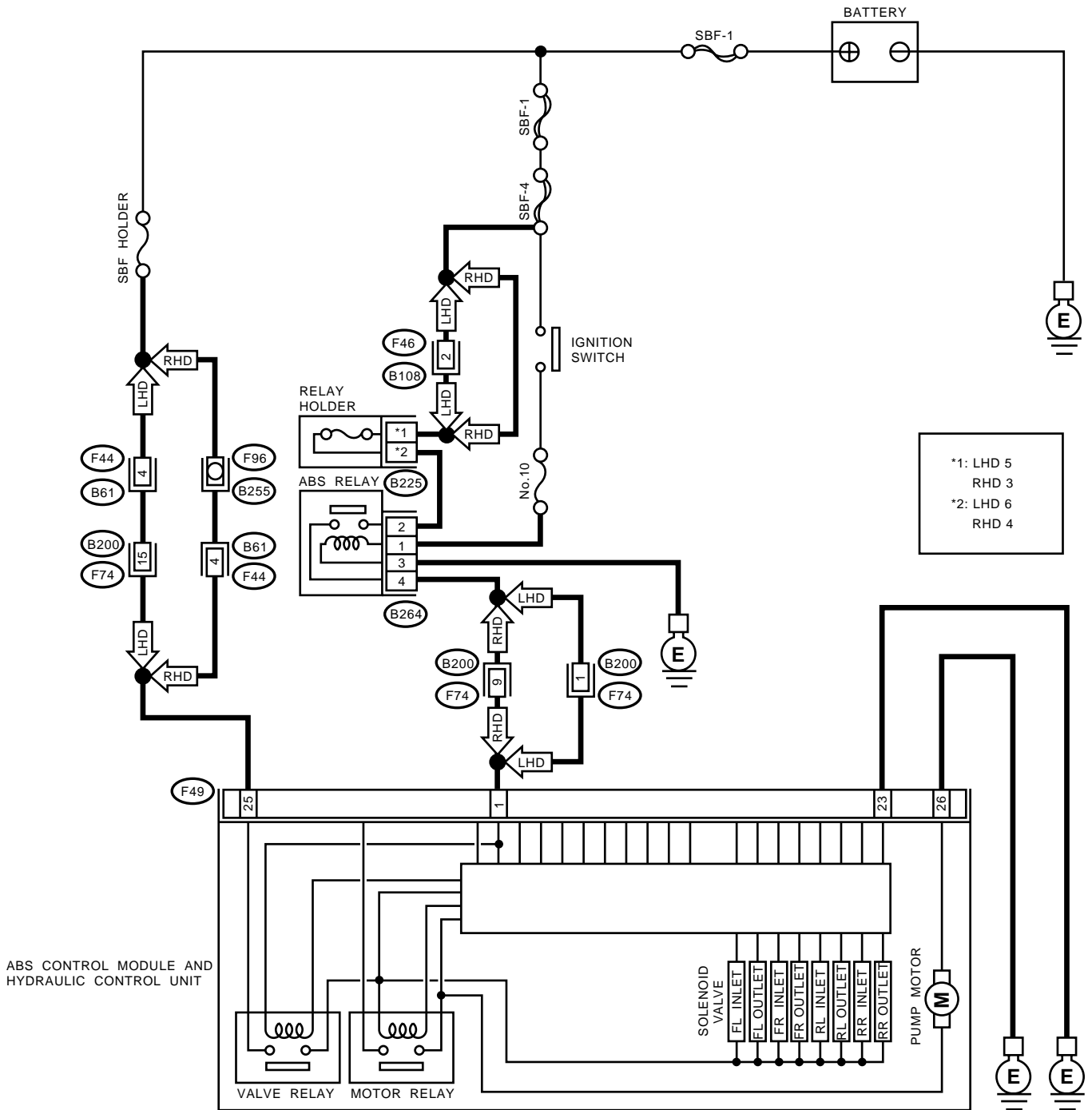

BR0042

DIAGNOSTICS CHART WITH DIAGNOSIS CONNECTOR

ABS (DIAGNOSTICS)

Step	Check	Yes	No
1 CHECK INPUT VOLTAGE OF ABSCM&H/U. 1) Turn ignition switch to OFF. 2) Disconnect connector from ABSCM&H/U. 3) Turn ignition switch to ON. 4) Measure voltage between ABSCM&H/U connector and chassis ground. Connector & terminal (F49) No. 25 (+) — Chassis ground (-):	Is the voltage between 10 and 15 V?	Go to step 2.	Repair harness/connector between battery and ABSCM&H/U and check fuse SBF-holder.
2 CHECK GROUND CIRCUIT OF MOTOR. 1) Turn ignition switch to OFF. 2) Measure resistance between ABSCM&H/U connector and chassis ground. Connector & terminal (F49) No. 26 — Chassis ground:	Is the resistance less than 0.5 Ω ?	Go to step 3.	Repair ABSCM&H/U ground harness.
3 CHECK INPUT VOLTAGE OF RELAY HOLDER. 1) Turn ignition switch to OFF. 2) Remove fuse. 3) Measure voltage between ABS relay connector and chassis ground. Connector & terminal LHD model (B225) No. 5 (+) — Chassis ground (-): RHD model (B225) No. 3 (+) — Chassis ground (-):	Is the voltage more than 10 V?	Go to step 4.	Repair open circuit in harness between battery and Relay holder connector.
4 CHECK RELAY HOLDER.	Is the fuse blown out?	Replace fuse.	Go to step 5.
5 CHECK INPUT VOLTAGE OF ABS RELAY. 1) Install fuse. 2) Remove ABS relay. 3) Turn ignition switch to ON. 4) Measure voltage between ABS relay connector and chassis ground. Connector & terminal (B264) No. 2 (+) — Chassis ground (-):	Is the voltage more than 10 V?	Go to step 6.	Repair open circuit in harness between battery and Relay holder connector.
6 CHECK INPUT VOLTAGE OF ABS RELAY. Measure voltage between ABS relay connector and chassis ground. Connector & terminal (B264) No. 1 (+) — Chassis ground (-):	Is the voltage more than 10 V?	Go to step 7.	Repair harness connector between battery, ignition switch and ABS relay.
7 CHECK GROUND CIRCUIT OF ABS RELAY. 1) Turn ignition switch to OFF. 2) Measure resistance between ABS relay connector and chassis ground. Connector & terminal (B264) No. 3 (+) — Chassis ground:	Is the resistance less than 5 Ω ?	Go to step 8.	Repair open circuit between ABS relay and chassis ground.
8 CHECK ABS RELAY. 1) Connect battery to ABS relay terminal No. 1 and 3. 2) Measure resistance between ABS relay terminals.	Is the resistance less than 10 Ω ?	Go to step 9.	Replace ABS relay.
9 CHECK INPUT VOLTAGE OF ABSCM&H/U. 1) Run the engine at idle. 2) Measure voltage between ABSCM&H/U connector and chassis ground. Connector & terminal (F49) No. 1 (+) — Chassis ground (-):	Is the voltage between 10 and 15 V?	Go to step 10.	Repair harness connector between battery, ignition switch and ABSCM&H/U.

DIAGNOSTICS CHART WITH DIAGNOSIS CONNECTOR

ABS (DIAGNOSTICS)

Step	Check	Yes	No
10 CHECK GROUND CIRCUIT OF ABSCM&H/U. 1) Turn ignition switch to OFF. 2) Measure resistance between ABSCM&H/U connector and chassis ground. Connector & terminal (F49) No. 23 — Chassis ground:	Is the resistance less than 0.5 Ω?	Go to step 11.	Repair ABSCM&H/U ground harness.
11 CHECK MOTOR OPERATION. Operate the sequence control. <Ref. to ABS-11, ABS Sequence Control.> NOTE: Use the diagnosis connector to operate the sequence control.	Can motor revolution noise (buzz) be heard when carrying out the sequence control?	Go to step 12.	Replace ABSCM&H/U. <Ref. to ABS-7, ABS Control Module and Hydraulic Control Unit (ABSCM&H/U).>
12 CHECK POOR CONTACT IN CONNECTORS. Turn ignition switch to OFF.	Is there poor contact in connector between generator, battery and ABSCM&H/U?	Repair connector.	Go to step 13.
13 CHECK ABSCM&H/U. 1) Connect all connectors. 2) Erase the memory. 3) Perform inspection mode. 4) Read out the trouble code.	Is the same trouble code as in the current diagnosis still being output?	Replace ABSCM&H/U. <Ref. to ABS-7, ABS Control Module and Hydraulic Control Unit (ABSCM&H/U).>	Go to step 14.
14 CHECK ANY OTHER TROUBLE CODES APPEARANCE.	Are other trouble codes being output?	Proceed with the diagnosis corresponding to the trouble code.	A temporary poor contact.

DIAGNOSTICS CHART WITH DIAGNOSIS CONNECTOR

ABS (DIAGNOSTICS)

DIAGNOSTICS CHART WITH DIAGNOSIS CONNECTOR

ABS (DIAGNOSTICS)

Z: TROUBLE CODE 54 — ABNORMAL STOP LIGHT SWITCH —

DIAGNOSIS:

- Faulty stop light switch

TROUBLE SYMPTOM:

- ABS does not operate.

WIRING DIAGRAM:

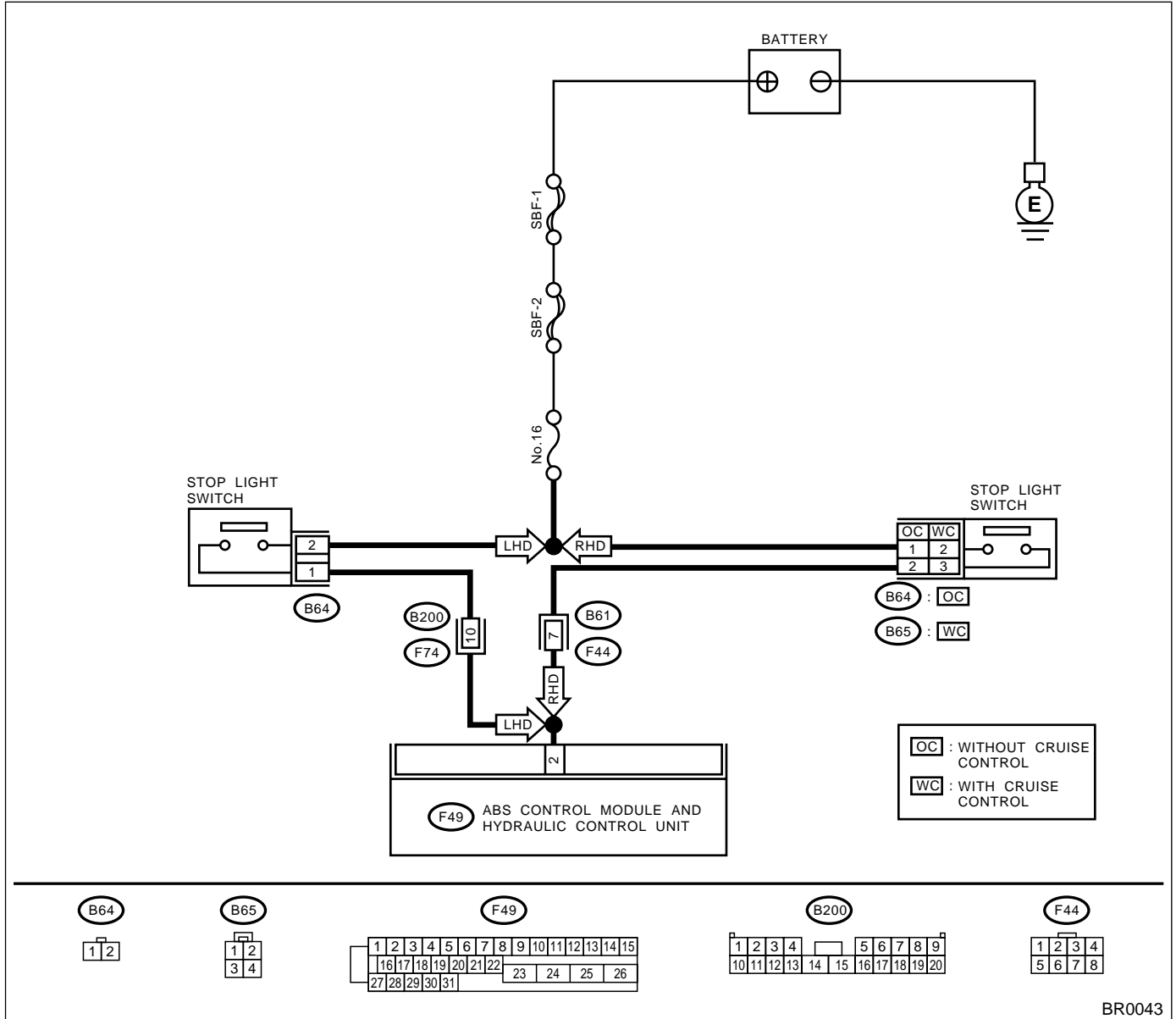

DIAGNOSTICS CHART WITH DIAGNOSIS CONNECTOR

ABS (DIAGNOSTICS)

Step	Check	Yes	No	
1	CHECK STOP LIGHTS COME ON. Depress the brake pedal.	Do stop lights come on?	Go to step 2.	Repair stop lights circuit.
2	CHECK OPEN CIRCUIT IN HARNESS. 1) Turn ignition switch to OFF. 2) Disconnect connector from ABSCM&H/U. 3) Depress brake pedal. 4) Measure voltage between ABSCM&H/U connector and chassis ground. Connector & terminal (F49) No. 2 (+) — Chassis ground (-):	Is the voltage between 10 and 15 V?	Go to step 3.	Repair harness between stop light switch and ABSCM&H/U.
3	CHECK POOR CONTACT IN CONNECTORS.	Is there poor contact in connector between stop light switch and ABSCM&H/U?	Repair connector.	Go to step 4.
4	CHECK ABSCM&H/U. 1) Connect all connectors. 2) Erase the memory. 3) Perform inspection mode. 4) Read out the trouble code.	Is the same trouble code as in the current diagnosis still being output?	Replace ABSCM&H/U. <Ref. to ABS-7, ABS Control Module and Hydraulic Control Unit (ABSCM&H/U).>	Go to step 5.
5	CHECK ANY OTHER TROUBLE CODES APPEARANCE.	Are other trouble codes being output?	Proceed with the diagnosis corresponding to the trouble code.	A temporary poor contact.

DIAGNOSTICS CHART WITH DIAGNOSIS CONNECTOR

ABS (DIAGNOSTICS)

AA:TROUBLE CODE 56 — ABNORMAL G SENSOR OUTPUT VOLTAGE —

DIAGNOSIS:

- Faulty G sensor output voltage

TROUBLE SYMPTOM:

- ABS does not operate.

WIRING DIAGRAM: LHD MODEL

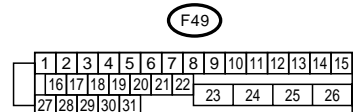
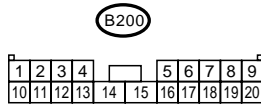
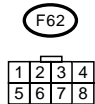
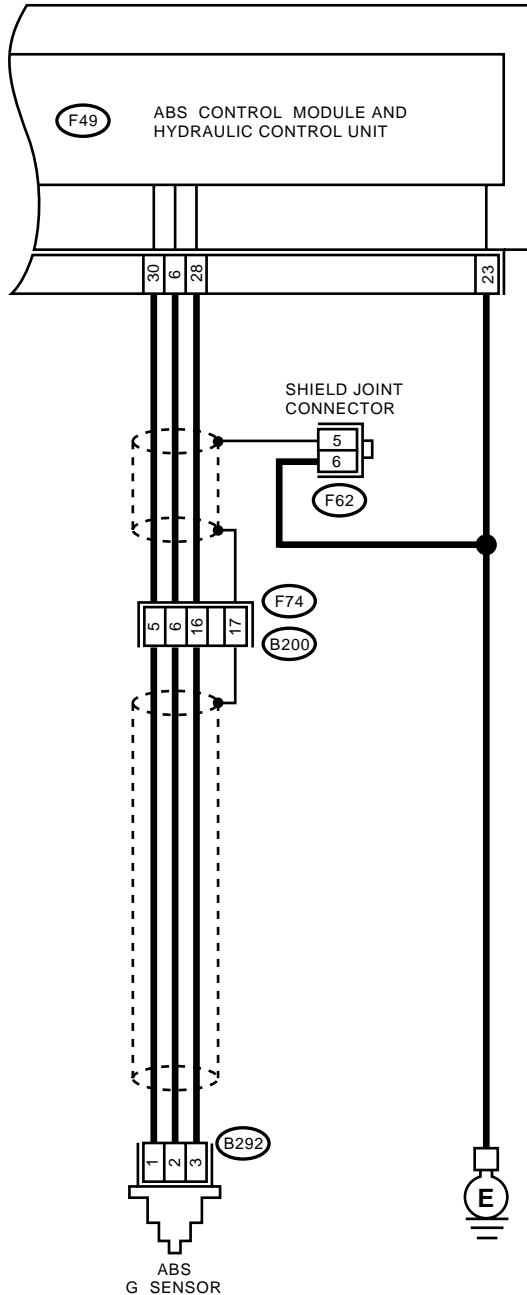

BR0044

DIAGNOSTICS CHART WITH DIAGNOSIS CONNECTOR

ABS (DIAGNOSTICS)

WIRING DIAGRAM: RHD MODEL

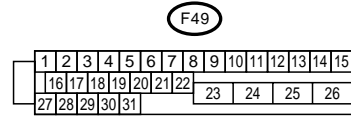
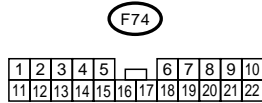
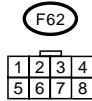
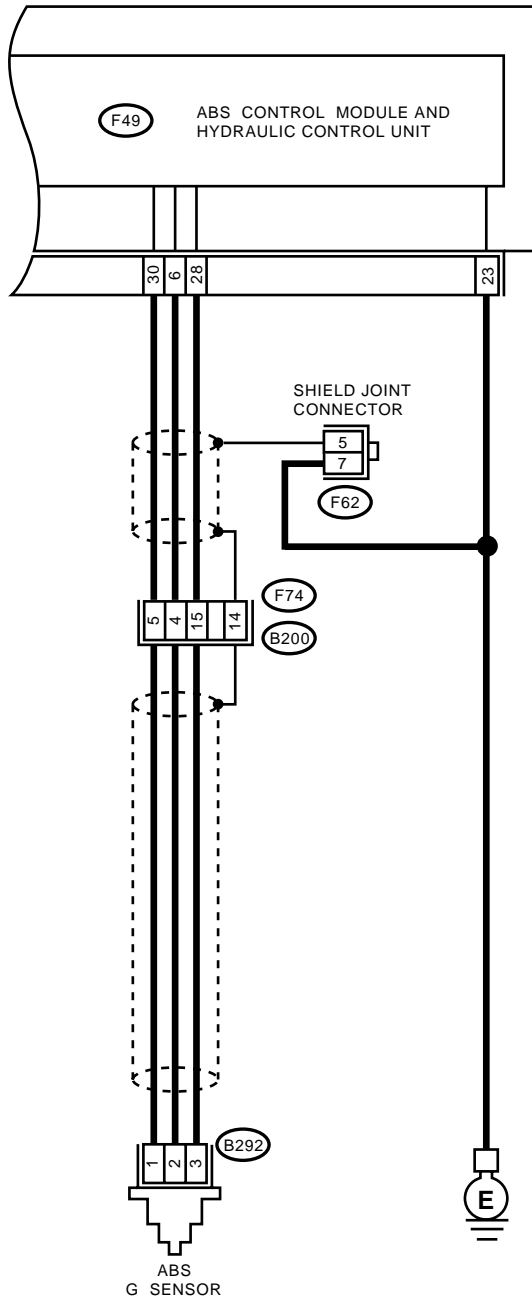

BR0045

DIAGNOSTICS CHART WITH DIAGNOSIS CONNECTOR

ABS (DIAGNOSTICS)

	Step	Check	Yes	No
1	CHECK ALL FOUR WHEELS FOR FREE TURNING.	Have the wheels been turned freely such as when the vehicle is lifted up, or operated on a rolling road?	The ABS is normal. Erase the trouble code.	Go to step 2.
2	CHECK SPECIFICATIONS OF ABSCM&H/U. Check specifications of the mark to the ABSCM&H/U. CA: AT (FWD) CB: MT (FWD) CC: AT (AWD) CD: MT (AWD)	Does the vehicle specification and the ABSCM&H/U specification match?	Replace ABSCM&H/U. <Ref. to ABS-7, ABS Control Module and Hydraulic Control Unit (ABSCM&H/U).> CAUTION: Be sure to turn ignition switch to OFF when removing ABSCM&H/U.	Go to step 3.
3	CHECK INPUT VOLTAGE OF G SENSOR. 1) Turn ignition switch to OFF. 2) Remove console box. 3) Disconnect G sensor from body. (Do not disconnect connector.) 4) Turn ignition switch to ON. 5) Measure voltage between G sensor connector terminals. Connector & terminal (B292) No. 1 (+) — No. 3 (-):	Is the voltage between 4.75 and 5.25 V?	Go to step 4.	Repair harness/connector between G sensor and ABSCM&H/U.
4	CHECK OPEN CIRCUIT IN G SENSOR OUTPUT HARNESS AND GROUND HARNESS. 1) Turn ignition switch to OFF. 2) Disconnect connector from ABSCM&H/U. 3) Measure resistance between ABSCM&H/U connector terminals. Connector & terminal (F49) No. 6 — No. 28:	Is the resistance between 4.3 and 4.9 kΩ?	Go to step 5.	Repair harness/connector between G sensor and ABSCM&H/U.
5	CHECK GROUND SHORT IN G SENSOR OUTPUT HARNESS. 1) Disconnect connector from G sensor. 2) Measure resistance between ABSCM&H/U connector and chassis ground. Connector & terminal (F49) No. 6 — Chassis ground:	Is the resistance more than 1 MΩ?	Go to step 6.	Repair harness between G sensor and ABSCM&H/U.
6	CHECK BATTERY SHORT OF HARNESS. Measure voltage between ABSCM&H/U connector and chassis ground. Connector & terminal (F49) No. 6 (+) — Chassis ground (-):	Is the voltage less than 1 V?	Go to step 7.	Repair harness between G sensor and ABSCM&H/U.
7	CHECK BATTERY SHORT OF HARNESS. 1) Turn ignition switch to ON. 2) Measure voltage between ABSCM&H/U connector and chassis ground. Connector & terminal (F49) No. 6 (+) — Chassis ground (-):	Is the voltage less than 1 V?	Go to step 8.	Repair harness between G sensor and ABSCM&H/U.

DIAGNOSTICS CHART WITH DIAGNOSIS CONNECTOR

ABS (DIAGNOSTICS)

Step	Check	Yes	No
8 CHECK GROUND SHORT OF HARNESS. Measure resistance between ABSCM&H/U connector and chassis ground. <i>Connector & terminal</i> <i>(F49) No. 28 — Chassis ground:</i>	Is the resistance more than 1 MΩ?	Go to step 9.	Repair harness between G sensor and ABSCM&H/U. Replace ABSCM&H/U. <Ref. to ABS-7, ABS Control Module and Hydraulic Control Unit (ABSCM&H/U).>
9 CHECK G SENSOR. 1)Turn ignition switch to OFF. 2)Remove G sensor from vehicle. 3)Connect connector to G sensor. 4)Connect connector to ABSCM&H/U. 5)Turn ignition switch to ON. 6)Measure voltage between G sensor connector terminals. <i>Connector & terminal</i> <i>(B292) No. 2 (+) — No. 3 (-):</i>	Is the voltage between 2.1 and 2.4 V when G sensor is horizontal?	Go to step 10.	Replace G sensor. <Ref. to ABS-22, G Sensor.>
10 CHECK G SENSOR. Measure voltage between G sensor connector terminals. <i>Connector & terminal</i> <i>(B292) No. 2 (+) — No. 3 (-):</i>	Is the voltage between 3.7 and 4.1 V when G sensor is inclined forwards to 90°?	Go to step 11.	Replace G sensor. <Ref. to ABS-22, G Sensor.>
11 CHECK G SENSOR. Measure voltage between G sensor connector terminals. <i>Connector & terminal</i> <i>(B292) No. 2 (+) — No. 3 (-):</i>	Is the voltage between 0.5 and 0.9 V when G sensor is inclined backwards to 90°?	Go to step 12.	Replace G sensor. <Ref. to ABS-22, G Sensor.>
12 CHECK POOR CONTACT IN CONNECTORS.	Is there poor contact in connector between ABSCM&H/U and G sensor?	Repair connector.	Go to step 13.
13 CHECK ABSCM&H/U. 1)Connect all connectors. 2)Erase the memory. 3)Perform inspection mode. 4)Read out the trouble code.	Is the same trouble code as in the current diagnosis still being output?	Replace ABSCM&H/U. <Ref. to ABS-7, ABS Control Module and Hydraulic Control Unit (ABSCM&H/U).>	Go to step 14.
14 CHECK ANY OTHER TROUBLE CODES APPEARANCE.	Are other trouble codes being output?	Proceed with the diagnosis corresponding to the trouble code.	A temporary poor contact.

DIAGNOSTICS CHART WITH DIAGNOSIS CONNECTOR

ABS (DIAGNOSTICS)

AB:SELECT MONITOR

Applicable cartridge of select monitor: <Ref. to ABS-10, SPECIAL TOOLS, PREPARATION TOOL, General Description.>

NOTE:

For basic handling of the select monitor, refer to its Operation Manual.

AC:TROUBLE CODES ARE DISPLAYED.

A maximum of 3 trouble codes are displayed in order of occurrence.

- If a particular trouble code is not properly stored in memory (due to a drop in ABSCM&H/U power supply, etc.) when a problem occurs, the trouble code, followed by a question mark "?", appears on the select monitor display. This shows it may be an unreliable reading.

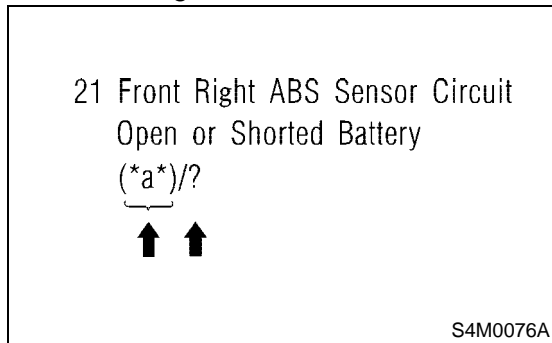

- *a* refers to the troubles in order of occurrence (Latest, Old, Older and Reference).

Display screen	Contents to be monitored
Latest	The most recent trouble code appears on the select monitor display.
Old	The second most recent trouble code appears on the select monitor display.
Older	The third most recent trouble code appears on the select monitor display.
Reference	A specified period of time preceding trouble code appears on the select monitor display.

AD:CLEAR MEMORY

Display screen	Contents to be monitored
Clear memory?	Function of clearing trouble code and freeze frame data.

AE:ANALOG DATA ARE DISPLAYED.

Display screen	Contents to be monitored
FR wheel speed	Wheel speed detected by the Front Right ABS sensor is displayed in km/h or mile/h.
FL wheel speed	Wheel speed detected by the Front Left ABS sensor is displayed in km/h or mile/h.
RR wheel speed	Wheel speed detected by the Rear Right ABS sensor is displayed in km/h or mile/h.
RL wheel speed	Wheel speed detected by the Rear Left ABS sensor is displayed in km/h or mile/h.
Stop light switch	Stop light switch monitor voltage is displayed.
G sensor output voltage	Refers to vehicle acceleration detecting by the analog G sensor. It appears on the select monitor display in volts.

AF:ON/OFF DATA ARE DISPLAYED.

Display screen	Contents to be monitored
Stop light switch	Stop light switch signal
Valve relay signal	Valve relay signal
Motor relay signal	Motor relay signal
ABS signal to TCM	ABS operation signal from ABS control module to TCM
ABS warning light	ABS warning light
Valve relay monitor	Valve relay operation monitor signal
Motor relay monitor	Motor relay operation monitor signal
CCM signal	ABS operation signal from ABS control module to TCM

AG:ABS SEQUENCE CONTROL

Display screen	Contents to be monitored	Index No.
ABS sequence control	Perform ABS sequence control by operating valve and pump motor sequentially.	<Ref. to ABS-11, ABS Sequence Control.>

AH:FREEZE FRAME DATA

NOTE:

- Data stored at the time of trouble occurrence is shown on display.
- Each time trouble occurs, the latest information is stored in the freeze frame data in memory.
- Freeze frame data will be memorized maximum to three.
- If freeze frame data is not properly stored in memory (due to a drop in ABSCM power supply, etc.), a trouble code, preceded by a question mark “?”, appears on the select monitor display. This shows it may be an unreliable reading.

Display screen	Contents to be monitored
FR wheel speed	Wheel speed detected by the Front Right ABS sensor is displayed in km/h or mile/h.
FL wheel speed	Wheel speed detected by the Front Left ABS sensor is displayed in km/h or mile/h.
RR wheel speed	Wheel speed detected by the Rear Right ABS sensor is displayed in km/h or mile/h.
RL wheel speed	Wheel speed detected by the Rear Left ABS sensor is displayed in km/h or mile/h.
ABSCM power voltage	Power (in volts) supplied to ABSCM&H/U appears on the select monitor display.
G sensor output voltage	Refers to vehicle acceleration detected by the analog G sensor. It appears on the select monitor display in volts.
Motor relay monitor	Motor relay operation monitor signal
Stop light switch	Stop light switch signal
ABS signal to TCM	ABS operation signal from ABS control module to TCM
ABS-AT control	ABS operation signal from ABS control module to TCM
ABS operation signal	ABS operation signal

DIAGNOSTICS CHART WITH SUBARU SELECT MONITOR

ABS (DIAGNOSTICS)

13. Diagnostics Chart with Subaru Select Monitor

A: COMMUNICATION FOR INITIALIZING IMPOSSIBLE

DIAGNOSIS:

- Faulty harness connector

TROUBLE SYMPTOM:

- ABS warning light remains on.

WIRING DIAGRAM:

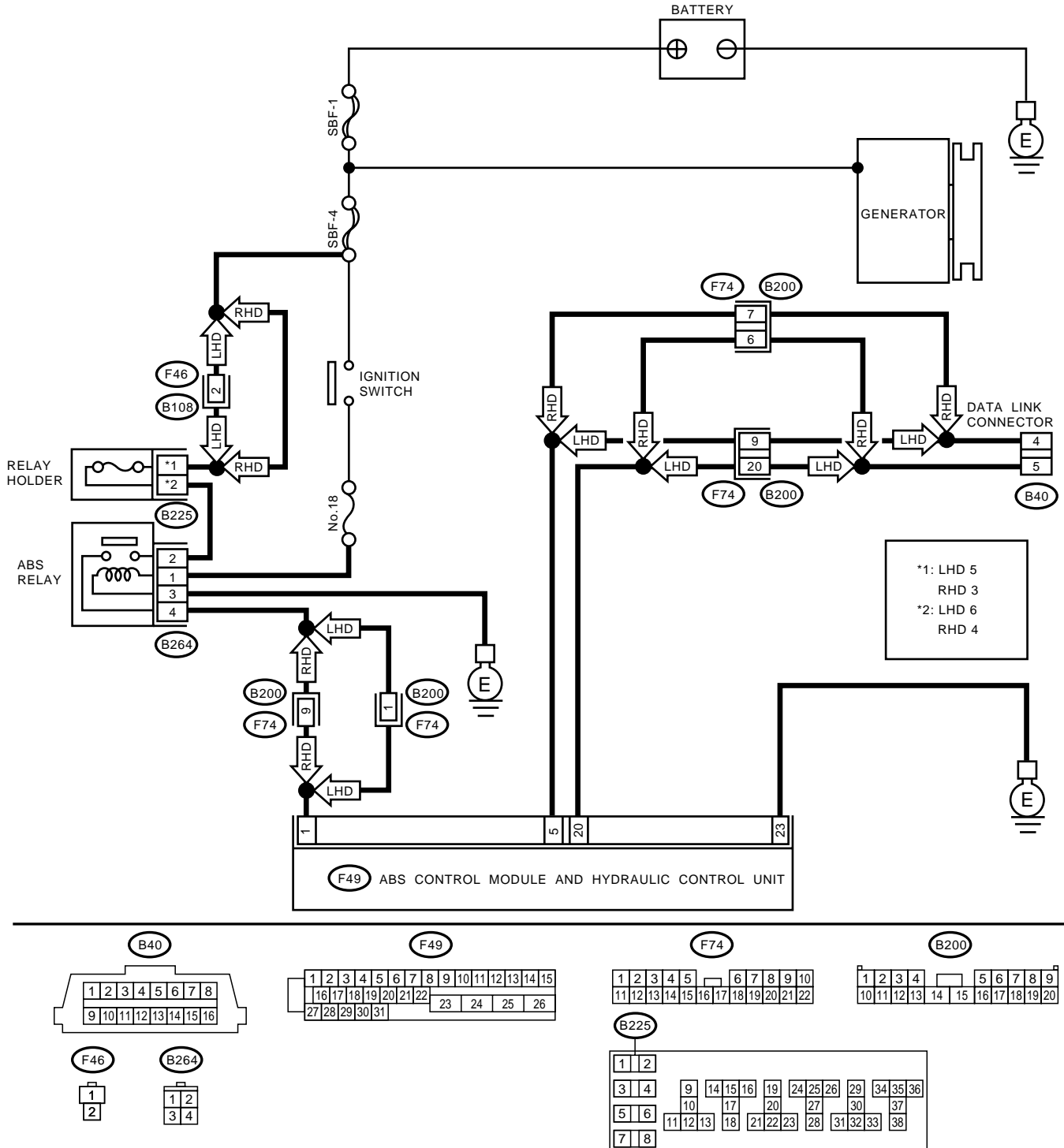

BR0046

DIAGNOSTICS CHART WITH SUBARU SELECT MONITOR

ABS (DIAGNOSTICS)

Step	Check	Yes	No	
1	CHECK IGNITION SWITCH.	Is ignition switch ON?	Go to step 2.	Turn ignition switch to ON, and select ABS mode using the select monitor.
2	CHECK BATTERY. 1) Turn ignition switch to OFF. 2) Measure battery voltage.	Is voltage more than 11 V?	Go to step 3.	Charge or replace battery.
3	CHECK BATTERY TERMINAL.	Is there poor contact at battery terminal?	Repair or tighten battery terminal.	Go to step 4.
4	CHECK COMMUNICATION OF SELECT MONITOR. 1) Turn ignition switch to OFF. 2) Using the select monitor, check whether communication to other system (such as engine, TCM, etc.) can be executed normally.	Are the name and year of the system displayed on the select monitor?	Go to step 10.	Go to step 5.
5	CHECK COMMUNICATION OF SELECT MONITOR. 1) Turn ignition switch to OFF. 2) Disconnect ABSCM&H/U connector. 3) Check whether communication to other systems (such as TCM, engine etc.) can be executed normally.	Are the name and year of the system displayed on the select monitor?	Go to step 10.	Go to step 6.
6	CHECK COMMUNICATION OF SELECT MONITOR. 1) Turn ignition switch to OFF. 2) Connect ABSCM&H/U connector. 3) Disconnect ECM connector. 4) Check whether communication to other systems (such as TCM, engine etc.) can be executed normally.	Are the name and year of the system displayed on the select monitor?	Inspect ECM.	Go to step 7.
7	CHECK COMMUNICATION OF SELECT MONITOR. 1) Turn ignition switch to OFF. 2) Connect ECM connector. 3) Disconnect TCM connector. 4) Check whether communication to other systems (such as engine etc.) can be executed normally.	Are the name and year of the system displayed on the select monitor?	Inspect TCM.	Go to step 8.
8	CHECK COMMUNICATION OF SELECT MONITOR. 1) Turn ignition switch to OFF. 2) Connect TCM connector. 3) Disconnect cruise control module connector. 4) Check whether communication to other systems (such as engine, TCM etc.) can be executed normally. NOTE: If the vehicle is not equipped with cruise control: Go to step 9.	Are the name and year of the system displayed on the select monitor?	Inspect cruise control module.	Go to step 9.

DIAGNOSTICS CHART WITH SUBARU SELECT MONITOR

ABS (DIAGNOSTICS)

Step	Check	Yes	No
9 CHECK HARNESS CONNECTOR BETWEEN EACH CONTROL MODULE AND DATA LINK CONNECTOR. 1) Turn ignition switch to OFF. 2) Disconnect TCM, ECM, ABSCM&H/U, and, cruise control module connectors. 3) Measure resistance between ABSCM&H/U connector and chassis ground. <i>Connector & terminal</i> <i>(B40) No. 5 — Chassis ground:</i> <i>(B40) No. 4 — Chassis ground:</i>	Is the resistance less than 1 Ω ?	Go to step 10.	Repair harness and connector between each control module and data link connector.
10 CHECK OUTPUT SIGNAL FOR ABSCM&H/U. 1) Turn ignition switch to ON. 2) Measure voltage between ABSCM&H/U and chassis ground. <i>Connector & terminal</i> <i>(B40) No. 5 (+) — Chassis ground (-):</i> <i>(B40) No. 4 (+) — Chassis ground (-):</i>	Is the voltage more than 1 V?	Repair harness and connector between each control module and data link connector.	Go to step 11.
11 CHECK HARNESS/CONNECTOR BETWEEN ABSCM&H/U AND DATA LINK CONNECTOR. Measure resistance between ABSCM&H/U connector and data link connector. <i>Connector & terminal</i> <i>(F49) No. 20 — (B40) No. 5:</i> <i>(F49) No. 5 — (B40) No. 4:</i>	Is the resistance less than 0.5 Ω ?	Repair harness and connector between ABSCM&H/U and data link connector.	Go to step 12.
12 CHECK INSTALLATION OF ABSCM&H/U CONNECTOR. Turn ignition switch to OFF.	Is ABSCM&H/U connector inserted into ABSCM&H/U until the clamp locks onto it?	Go to step 13.	Insert ABSCM&H/U connector into ABSCM&H/U.
13 CHECK INPUT VOLTAGE OF RELAY HOLDER. 1) Turn ignition switch to OFF. 2) Remove fuse. 3) Measure voltage between ABS relay connector and chassis ground. <i>Connector & terminal</i> <i>LHD model</i> <i>(B225) No. 5 (+) — Chassis ground (-):</i> <i>RHD model</i> <i>(B225) No. 3 (+) — Chassis ground (-):</i>	Is the voltage more than 10 V?	Go to step 14.	Repair open circuit in harness between battery and Relay holder connector.
14 CHECK RELAY HOLDER.	Is the fuse blown out?	Replace fuse.	Go to step 15.
15 CHECK INPUT VOLTAGE OF ABS RELAY. 1) Install fuse. 2) Remove ABS relay. 3) Turn ignition switch to ON. 4) Measure voltage between ABS relay connector and chassis ground. <i>Connector & terminal</i> <i>(B264) No. 2 (+) — Chassis ground (-):</i>	Is the voltage more than 10 V?	Go to step 16.	Repair open circuit in harness between battery and Relay holder connector.
16 CHECK INPUT VOLTAGE OF ABS RELAY. Measure voltage between ABS relay connector and chassis ground. <i>Connector & terminal</i> <i>(B264) No. 1 (+) — Chassis ground (-):</i>	Is the voltage more than 10 V?	Go to step 17.	Repair harness connector between battery, ignition switch and ABS relay.

DIAGNOSTICS CHART WITH SUBARU SELECT MONITOR

ABS (DIAGNOSTICS)

Step	Check	Yes	No
17 CHECK GROUND CIRCUIT OF ABS RELAY. 1) Turn ignition switch to OFF. 2) Measure resistance between ABS relay connector and chassis ground. Connector & terminal (B264) No. 3 (+) — Chassis ground:	Is the resistance less than 5 Ω?	Go to step 18 .	Repair open circuit between ABS relay and chassis ground.
18 CHECK ABS RELAY. 1) Connect battery to ABS relay terminal No. 1 and 3. 2) Measure resistance between ABS relay terminals.	Is the resistance less than 10 Ω?	Go to step 19 .	Replace ABS relay.
19 CHECK POWER SUPPLY CIRCUIT. 1) Turn ignition switch to ON (engine OFF). 2) Measure ignition power supply voltage between ABSCM&H/U connector and chassis ground. Connector & terminal (F49) No. 1 (+) — Chassis ground (-):	Is the voltage more than 10 V?	Go to step 20 .	Repair open circuit in harness between ABSCM&H/U and battery.
20 CHECK HARNESS CONNECTOR BETWEEN ABSCM&H/U AND CHASSIS GROUND. 1) Turn ignition switch to OFF. 2) Disconnect connector from ABSCM&H/U and transmission. 3) Measure resistance of harness between ABSCM&H/U and chassis ground. Connector & terminal (F49) No. 23 — Chassis ground:	Is the resistance less than 1 Ω?	Go to step 21 .	Repair open circuit in harness between ABSCM&H/U and inhibitor side connector, and poor contact in coupling connector.
21 CHECK POOR CONTACT IN CONNECTORS.	Is there poor contact in control module power supply, ground line and data link connector?	Repair connector.	Replace ABSCM&H/U. <Ref. to ABS-7, ABS Control Module and Hydraulic Control Unit (ABSCM&H/U).>

DIAGNOSTICS CHART WITH SUBARU SELECT MONITOR

ABS (DIAGNOSTICS)

B: NO TROUBLE CODE

DIAGNOSIS:

- ABS warning light circuit is shorted.

TROUBLE SYMPTOM:

- ABS warning light remains on.
- NO TROUBLE CODE displayed on the select monitor.

NOTE:

When the ABS warning light is OFF and “NO TROUBLE CODE” is displayed on the select monitor, the system is in normal condition.

DIAGNOSTICS CHART WITH SUBARU SELECT MONITOR

ABS (DIAGNOSTICS)

WIRING DIAGRAM: LHD MODEL

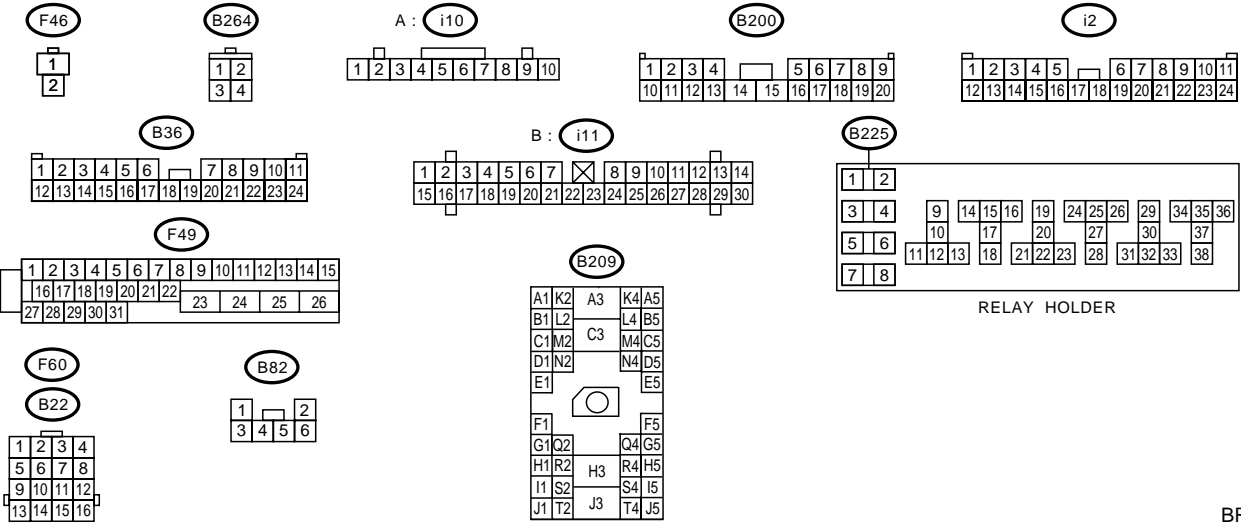
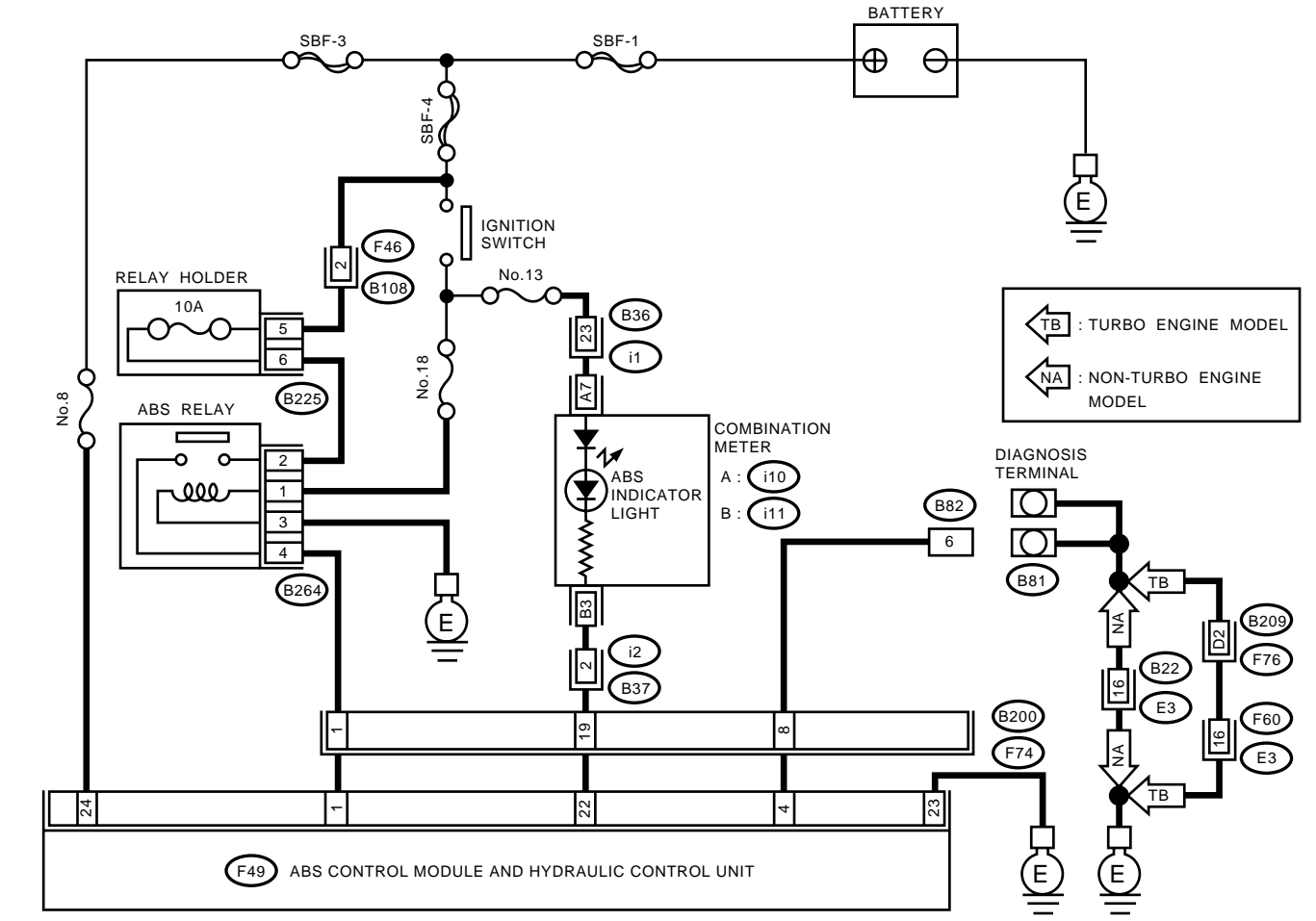

BR0035

DIAGNOSTICS CHART WITH SUBARU SELECT MONITOR

ABS (DIAGNOSTICS)

WIRING DIAGRAM: RHD MODEL

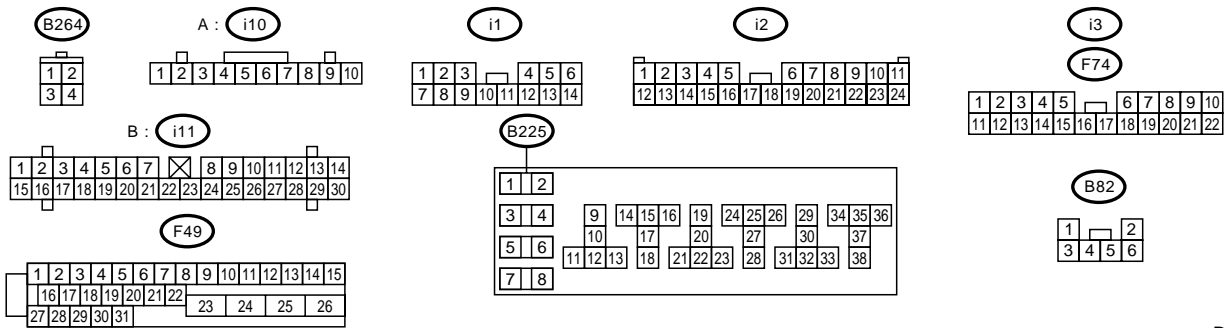
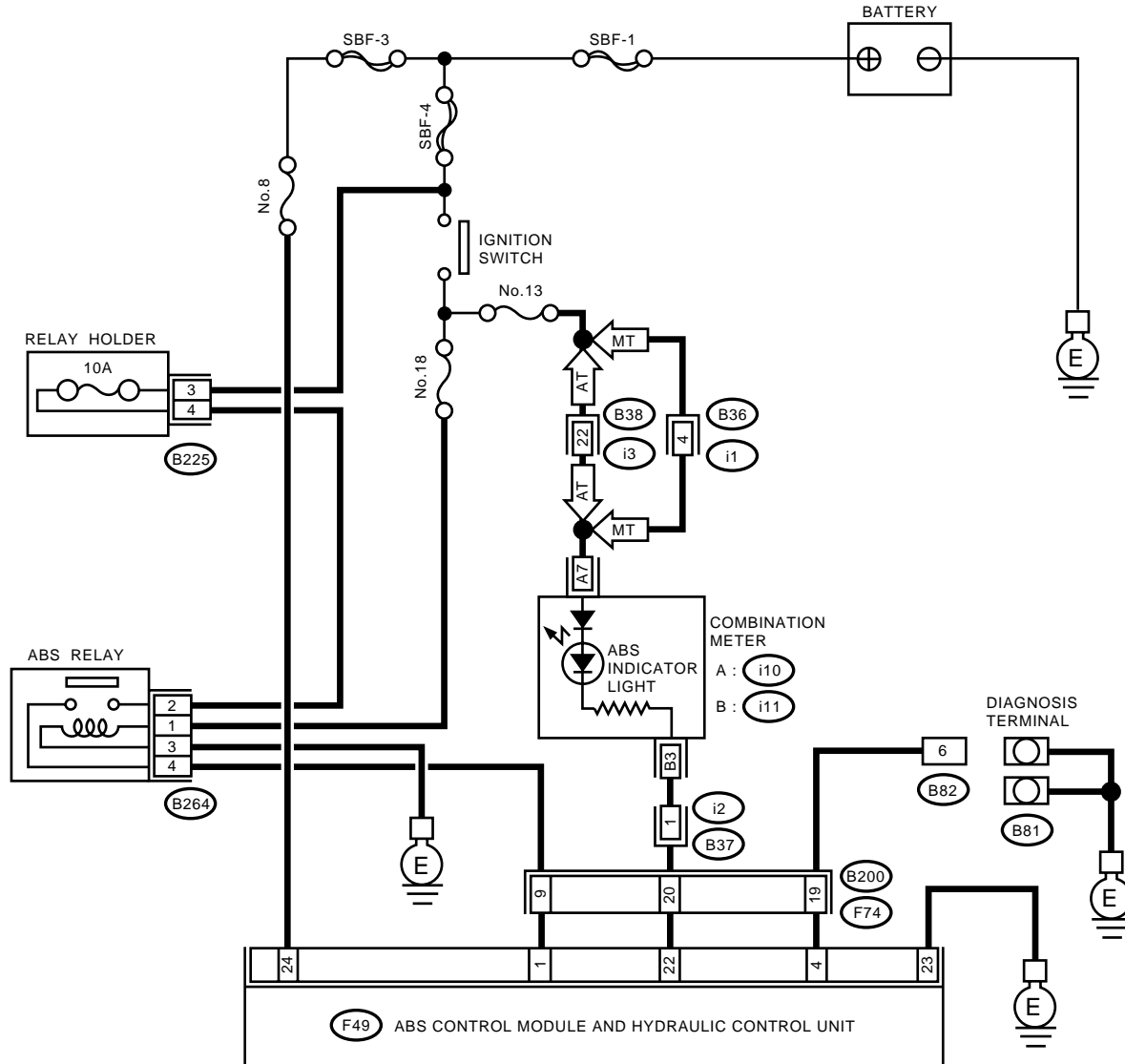

BR0036

DIAGNOSTICS CHART WITH SUBARU SELECT MONITOR

ABS (DIAGNOSTICS)

Step	Check	Yes	No
1 CHECK WIRING HARNESS. 1) Turn ignition switch to OFF. 2) Disconnect connector (F74) from connector (B200). 3) Turn ignition switch to ON.	Does the ABS warning light remain off?	Go to step 2.	Repair front wiring harness.
2 CHECK PROJECTION AT ABSCM&H/U. 1) Turn ignition switch to OFF. 2) Disconnect connector from ABSCM&H/U. 3) Check for broken projection at the ABSCM&H/U terminal.	Are the projection broken?	Go to step 3.	Replace ABSCM&H/U. <Ref. to ABS-7, ABS Control Module and Hydraulic Control Unit (ABSCM&H/U).>
3 CHECK ABSCM&H/U. Measure resistance between ABSCM&H/U terminals. <i>Terminals</i> <i>No. 22 — No. 23:</i>	Is the resistance more than 1 MΩ?	Go to step 4.	Replace ABSCM&H/U. <Ref. to ABS-7, ABS Control Module and Hydraulic Control Unit (ABSCM&H/U).>
4 CHECK WIRING HARNESS. Measure resistance between connector (F45) and chassis ground. <i>Connector & terminal</i> <i>(F74) No. 19 — Chassis ground:</i>	Is the resistance less than 0.5 Ω?	Go to step 5.	Repair harness.
5 CHECK WIRING HARNESS. 1) Connect connector to ABSCM&H/U. 2) Measure resistance between connector (F45) and chassis ground. <i>Connector & terminal</i> <i>(F74) No. 19 — Chassis ground:</i>	Is the resistance more than 1 MΩ?	Go to step 6.	Repair harness.
6 CHECK POOR CONTACT IN ABSCM&H/U CONNECTOR.	Is there poor contact in ABSCM&H/U connector?	Repair connector.	Replace ABSCM&H/U. <Ref. to ABS-7, ABS Control Module and Hydraulic Control Unit (ABSCM&H/U).>

DIAGNOSTICS CHART WITH SUBARU SELECT MONITOR

ABS (DIAGNOSTICS)

C: TROUBLE CODE 21

— OPEN OR SHORT CIRCUIT IN FRONT RIGHT ABS SENSOR CIRCUIT —

NOTE:

For the diagnostic procedure, refer to TROUBLE CODE 27. <Ref. to ABS-106, TROUBLE CODE 27 — OPEN OR SHORT CIRCUIT IN REAR LEFT ABS SENSOR CIRCUIT —, Diagnostics Chart with Subaru Select Monitor.>

D: TROUBLE CODE 23

— OPEN OR SHORT CIRCUIT IN FRONT LEFT ABS SENSOR CIRCUIT —

NOTE:

For the diagnostic procedure, refer to TROUBLE CODE 27. <Ref. to ABS-106, TROUBLE CODE 27 — OPEN OR SHORT CIRCUIT IN REAR LEFT ABS SENSOR CIRCUIT —, Diagnostics Chart with Subaru Select Monitor.>

E: TROUBLE CODE 25

— OPEN OR SHORT CIRCUIT IN REAR RIGHT ABS SENSOR CIRCUIT —

NOTE:

For the diagnostic procedure, refer to TROUBLE CODE 27. <Ref. to ABS-106, TROUBLE CODE 27 — OPEN OR SHORT CIRCUIT IN REAR LEFT ABS SENSOR CIRCUIT —, Diagnostics Chart with Subaru Select Monitor.>

DIAGNOSTICS CHART WITH SUBARU SELECT MONITOR

ABS (DIAGNOSTICS)

DIAGNOSTICS CHART WITH SUBARU SELECT MONITOR

ABS (DIAGNOSTICS)

F: TROUBLE CODE 27

— OPEN OR SHORT CIRCUIT IN REAR LEFT ABS SENSOR CIRCUIT —

DIAGNOSIS:

- Faulty ABS sensor (Broken wire, input voltage too high)
- Faulty harness connector

TROUBLE SYMPTOM:

- ABS does not operate.

WIRING DIAGRAM: LHD MODEL

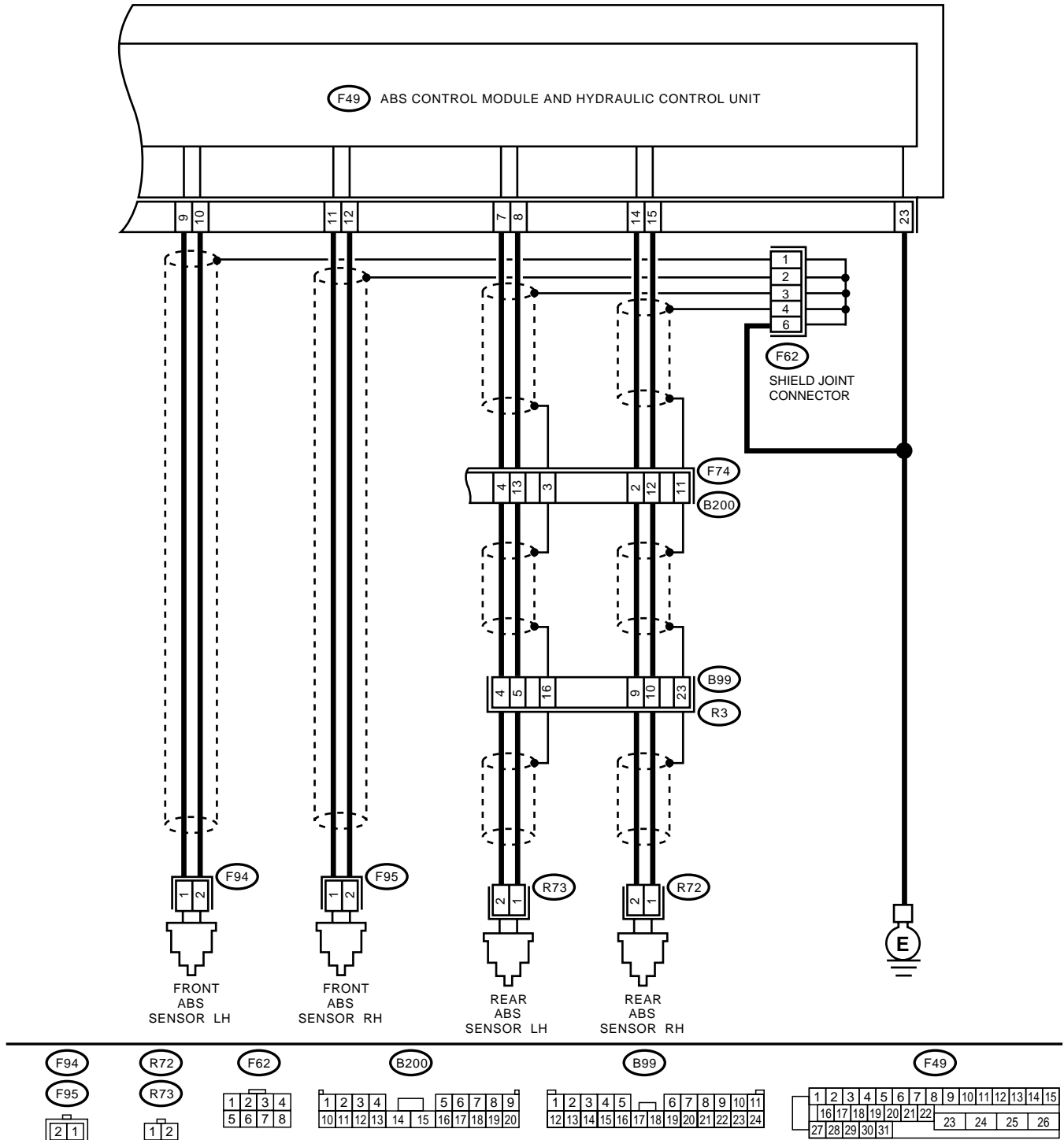

BR0037

DIAGNOSTICS CHART WITH SUBARU SELECT MONITOR

ABS (DIAGNOSTICS)

WIRING DIAGRAM: RHD MODEL

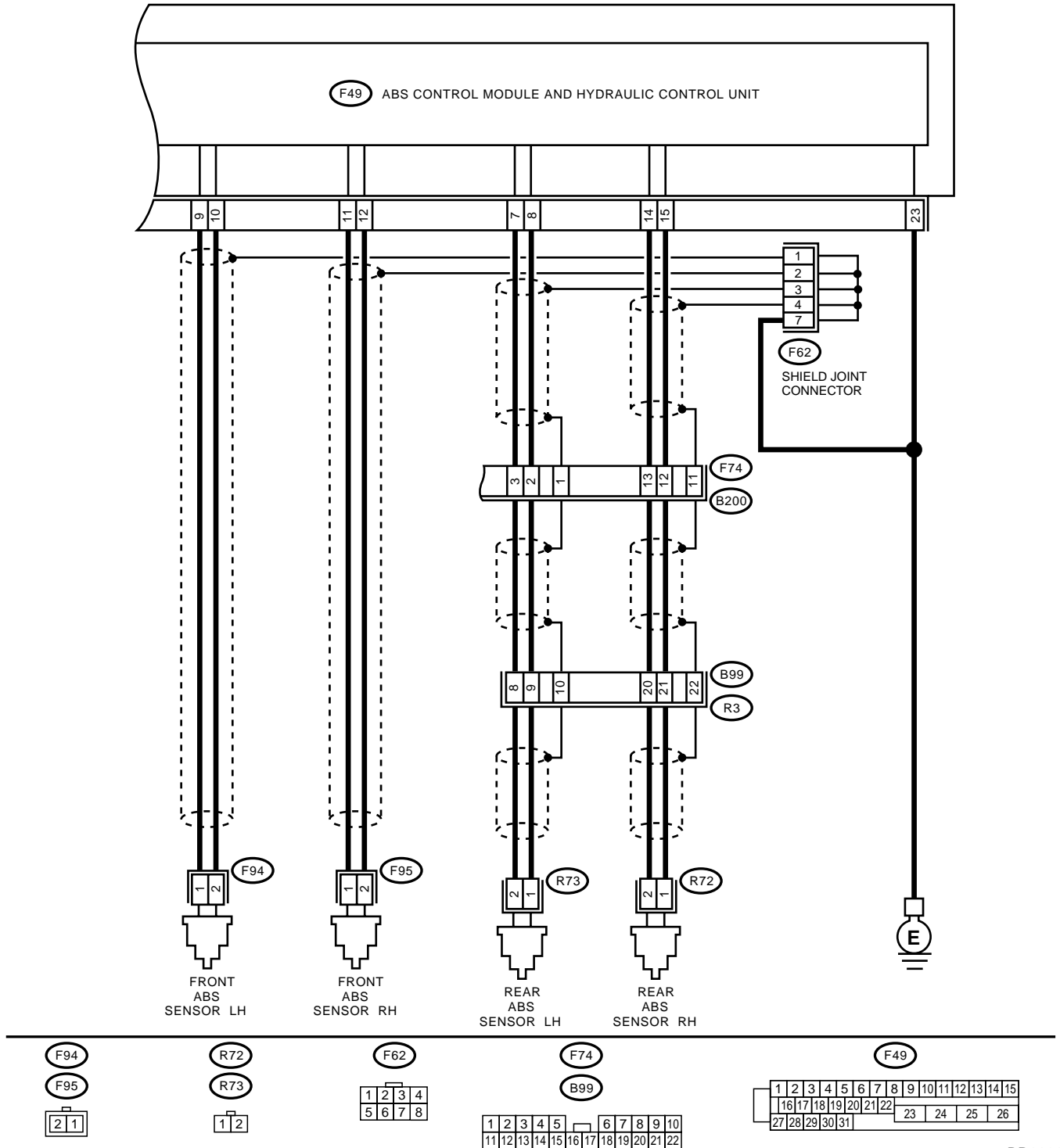

BR0038

DIAGNOSTICS CHART WITH SUBARU SELECT MONITOR

ABS (DIAGNOSTICS)

Step	Check	Yes	No
1 CHECK OUTPUT OF ABS SENSOR USING SELECT MONITOR. 1) Select "Current data display & Save" on the select monitor. 2) Read the ABS sensor output corresponding to the faulty system in the select monitor data display mode.	Does the speed indicated on the display change in response to the speedometer reading during acceleration/deceleration when the steering wheel is in the straight-ahead position?	Go to step 2.	Go to step 8.
2 CHECK INSTALLATION OF ABS SENSOR. Tightening torque: 32±10 N·m (3.3±1.0 kgf-m, 24±7 ft-lb)	Are the ABS sensor installation bolts tightened securely?	Go to step 3.	Tighten ABS sensor installation bolts securely.
3 CHECK ABS SENSOR GAP. Measure tone wheel to ABS sensor piece gap over entire perimeter of the wheel. Front wheel 0.3 — 0.8 mm (0.012 — 0.031 in) Rear wheel 0.7 — 1.2 mm (0.028 — 0.047 in)	Is the gap within the specifications?	Go to step 4.	Adjust the gap. NOTE: Adjust the gap using spacers (Part No. 26755AA000). If spacers cannot correct the gap, replace worn sensor or worn tone wheel.
4 CHECK TONE WHEEL RUNOUT. Measure tone wheel runout.	Is the runout less than 0.05 mm (0.0020 in)?	Go to step 5.	Replace tone wheel. Front: <Ref. to ABS-20, Front Tone Wheel.> Rear: <Ref. to ABS-21, Rear Tone Wheel.>
5 CHECK POOR CONTACT IN CONNECTORS. Turn ignition switch to OFF.	Is there poor contact in connectors between ABSCM&H/U and ABS sensor?	Repair connector.	Go to step 6.
6 CHECK ABSCM&H/U. 1) Connect all connectors. 2) Erase the memory. 3) Perform inspection mode. 4) Read out the trouble code.	Is the same trouble code as in the current diagnosis still being output?	Replace ABSCM&H/U. <Ref. to ABS-7, ABS Control Module and Hydraulic Control Unit (ABSCM&H/U).>	Go to step 7.
7 CHECK ANY OTHER TROUBLE CODES APPEARANCE.	Are other trouble codes being output?	Proceed with the diagnosis corresponding to the trouble code.	A temporary poor contact. NOTE: Check harness and connectors between ABSCM&H/U and ABS sensor.
8 CHECK ABS SENSOR. 1) Turn ignition switch to OFF. 2) Disconnect connector from ABS sensor. 3) Measure resistance of ABS sensor connector terminals. Terminal Front RH No. 1 — No. 2: Front LH No. 1 — No. 2: Rear RH No. 1 — No. 2: Rear LH No. 1 — No. 2:	Is the resistance between 1 and 1.5 kΩ?	Go to step 9.	Replace ABS sensor. Front: <Ref. to ABS-14, Front ABS Sensor.> Rear: <Ref. to ABS-17, Rear ABS Sensor.>

DIAGNOSTICS CHART WITH SUBARU SELECT MONITOR

ABS (DIAGNOSTICS)

Step	Check	Yes	No
<p>9 CHECK BATTERY SHORT OF ABS SENSOR. 1)Disconnect connector from ABSCM&H/U. 2)Measure voltage between ABS sensor and chassis ground. Terminal <i>Front RH No. 1 (+) — Chassis ground (-):</i> <i>Front LH No. 1 (+) — Chassis ground (-):</i> <i>Rear RH No. 1 (+) — Chassis ground (-):</i> <i>Rear LH No. 1 (+) — Chassis ground (-):</i></p>	Is the voltage less than 1 V?	Go to step 10.	Replace ABS sensor. Front: <Ref. to ABS-14, Front ABS Sensor.> Rear: <Ref. to ABS-17, Rear ABS Sensor.>
<p>10 CHECK BATTERY SHORT OF ABS SENSOR. 1)Turn ignition switch to ON. 2)Measure voltage between ABS sensor and chassis ground. Terminal <i>Front RH No. 1 (+) — Chassis ground (-):</i> <i>Front LH No. 1 (+) — Chassis ground (-):</i> <i>Rear RH No. 1 (+) — Chassis ground (-):</i> <i>Rear LH No. 1 (+) — Chassis ground (-):</i></p>	Is the voltage less than 1 V?	Go to step 11.	Replace ABS sensor. Front: <Ref. to ABS-14, Front ABS Sensor.> Rear: <Ref. to ABS-17, Rear ABS Sensor.>
<p>11 CHECK HARNESS/CONNECTOR BETWEEN ABSCM&H/U AND ABS SENSOR. 1)Turn ignition switch to OFF. 2)Connect connector to ABS sensor. 3)Measure resistance between ABSCM&H/U connector terminals. Connector & terminal <i>Trouble code 21 / (F49) No. 11 — No. 12:</i> <i>Trouble code 23 / (F49) No. 9 — No. 10:</i> <i>Trouble code 25 / (F49) No. 14 — No. 15:</i> <i>Trouble code 27 / (F49) No. 7 — No. 8:</i></p>	Is the resistance between 1 and 1.5 kΩ?	Go to step 12.	Repair harness/connector between ABSCM&H/U and ABS sensor.
<p>12 CHECK BATTERY SHORT OF HARNESS. Measure voltage between ABSCM&H/U connector and chassis ground. Connector & terminal <i>Trouble code 21 / (F49) No. 11 (+) — Chassis ground (-):</i> <i>Trouble code 23 / (F49) No. 9 (+) — Chassis ground (-):</i> <i>Trouble code 25 / (F49) No. 14 (+) — Chassis ground (-):</i> <i>Trouble code 27 / (F49) No. 7 (+) — Chassis ground (-):</i></p>	Is the voltage less than 1 V?	Go to step 13.	Repair harness between ABSCM&H/U and ABS sensor.
<p>13 CHECK BATTERY SHORT OF HARNESS. 1)Turn ignition switch to ON. 2)Measure voltage between ABSCM&H/U connector and chassis ground. Connector & terminal <i>Trouble code 21 / (F49) No. 11 (+) — Chassis ground (-):</i> <i>Trouble code 23 / (F49) No. 9 (+) — Chassis ground (-):</i> <i>Trouble code 25 / (F49) No. 14 (+) — Chassis ground (-):</i> <i>Trouble code 27 / (F49) No. 7 (+) — Chassis ground (-):</i></p>	Is the voltage less than 1 V?	Go to step 14.	Repair harness between ABSCM&H/U and ABS sensor.
<p>14 CHECK INSTALLATION OF ABS SENSOR. Tightening torque: 32±10 N·m (3.3±1.0 kgf·m, 24±7 ft·lb)</p>	Are the ABS sensor installation bolts tightened securely?	Go to step 15.	Tighten ABS sensor installation bolts securely.

DIAGNOSTICS CHART WITH SUBARU SELECT MONITOR

ABS (DIAGNOSTICS)

Step	Check	Yes	No
15 CHECK ABS SENSOR GAP. Measure tone wheel to ABS sensor piece gap over entire perimeter of the wheel. <i>Front wheel</i> 0.3 — 0.8 mm (0.012 — 0.031 in) <i>Rear wheel</i> 0.7 — 1.2 mm (0.028 — 0.047 in)	Is the gap within the specifications?	Go to step 16.	Adjust the gap. NOTE: Adjust the gap using spacers (Part No. 26755AA000). If spacers cannot correct the gap, replace worn sensor or worn tone wheel.
16 CHECK TONE WHEEL RUNOUT. Measure tone wheel runout.	Is the runout less than 0.05 mm (0.0020 in)?	Go to step 17.	Replace tone wheel. Front: <Ref. to ABS-20, Front Tone Wheel.> Rear: <Ref. to ABS-21, Rear Tone Wheel.>
17 CHECK GROUND SHORT OF ABS SENSOR. 1)Turn ignition switch to ON. 2)Measure resistance between ABS sensor and chassis ground. <i>Terminal</i> <i>Front RH No. 1 — Chassis ground:</i> <i>Front LH No. 1 — Chassis ground:</i> <i>Rear RH No. 1 — Chassis ground:</i> <i>Rear LH No. 1 — Chassis ground:</i>	Is the resistance more than 1 MΩ?	Go to step 18.	Replace ABS sensor and ABSCM&H/U. Front: <Ref. to ABS-14, Front ABS Sensor.> Rear: <Ref. to ABS-17, Rear ABS Sensor.> and <Ref. to ABS-7, ABS Control Module and Hydraulic Control Unit (ABSCM&H/U).>
18 CHECK GROUND SHORT OF HARNESS. 1)Turn ignition switch to OFF. 2)Connect connector to ABS sensor. 3)Measure resistance between ABSCM&H/U connector terminal and chassis ground. <i>Connector & terminal</i> <i>Trouble code 21 / (F49) No. 11 — Chassis ground:</i> <i>Trouble code 23 / (F49) No. 9 — Chassis ground:</i> <i>Trouble code 25 / (F49) No. 14 — Chassis ground:</i> <i>Trouble code 27 / (F49) No. 7 — Chassis ground:</i>	Is the resistance more than 1 MΩ?	Go to step 19.	Repair harness between ABSCM&H/U and ABS sensor. And replace ABSCM&H/U. <Ref. to ABS-7, ABS Control Module and Hydraulic Control Unit (ABSCM&H/U).>
19 CHECK POOR CONTACT IN CONNECTORS.	Is there poor contact in connectors between ABSCM&H/U and ABS sensor?	Repair connector.	Go to step 20.
20 CHECK ABSCM&H/U. 1)Connect all connectors. 2)Erase the memory. 3)Perform inspection mode. 4)Read out the trouble code.	Is the same trouble code as in the current diagnosis still being output?	Replace ABSCM&H/U.	Go to step 21.

DIAGNOSTICS CHART WITH SUBARU SELECT MONITOR

ABS (DIAGNOSTICS)

	Step	Check	Yes	No
21	CHECK ANY OTHER TROUBLE CODES APPEARANCE.	Are other trouble codes being output?	Proceed with the diagnosis corresponding to the trouble code.	A temporary poor contact. NOTE: Check harness and connectors between AB-SCM&H/U and ABS sensor.

DIAGNOSTICS CHART WITH SUBARU SELECT MONITOR

ABS (DIAGNOSTICS)

G: TROUBLE CODE 22

— FRONT RIGHT ABNORMAL ABS SENSOR SIGNAL —

NOTE:

For the diagnostic procedure, refer to TROUBLE CODE 28. <Ref. to ABS-114, TROUBLE CODE 28 — REAR LEFT ABNORMAL ABS SENSOR SIGNAL —, Diagnostics Chart with Subaru Select Monitor.>

H: TROUBLE CODE 24

— FRONT LEFT ABNORMAL ABS SENSOR SIGNAL —

NOTE:

For the diagnostic procedure, refer to TROUBLE CODE 28. <Ref. to ABS-114, TROUBLE CODE 28 — REAR LEFT ABNORMAL ABS SENSOR SIGNAL —, Diagnostics Chart with Subaru Select Monitor.>

I: TROUBLE CODE 26

— REAR RIGHT ABNORMAL ABS SENSOR SIGNAL —

NOTE:

For the diagnostic procedure, refer to TROUBLE CODE 28. <Ref. to ABS-114, TROUBLE CODE 28 — REAR LEFT ABNORMAL ABS SENSOR SIGNAL —, Diagnostics Chart with Subaru Select Monitor.>

DIAGNOSTICS CHART WITH SUBARU SELECT MONITOR

ABS (DIAGNOSTICS)

DIAGNOSTICS CHART WITH SUBARU SELECT MONITOR

ABS (DIAGNOSTICS)

J: TROUBLE CODE 28 — REAR LEFT ABNORMAL ABS SENSOR SIGNAL —

DIAGNOSIS:

- Faulty ABS sensor signal (noise, irregular signal, etc.)
- Faulty harness/connector

TROUBLE SYMPTOM:

- ABS does not operate.

WIRING DIAGRAM: LHD MODEL

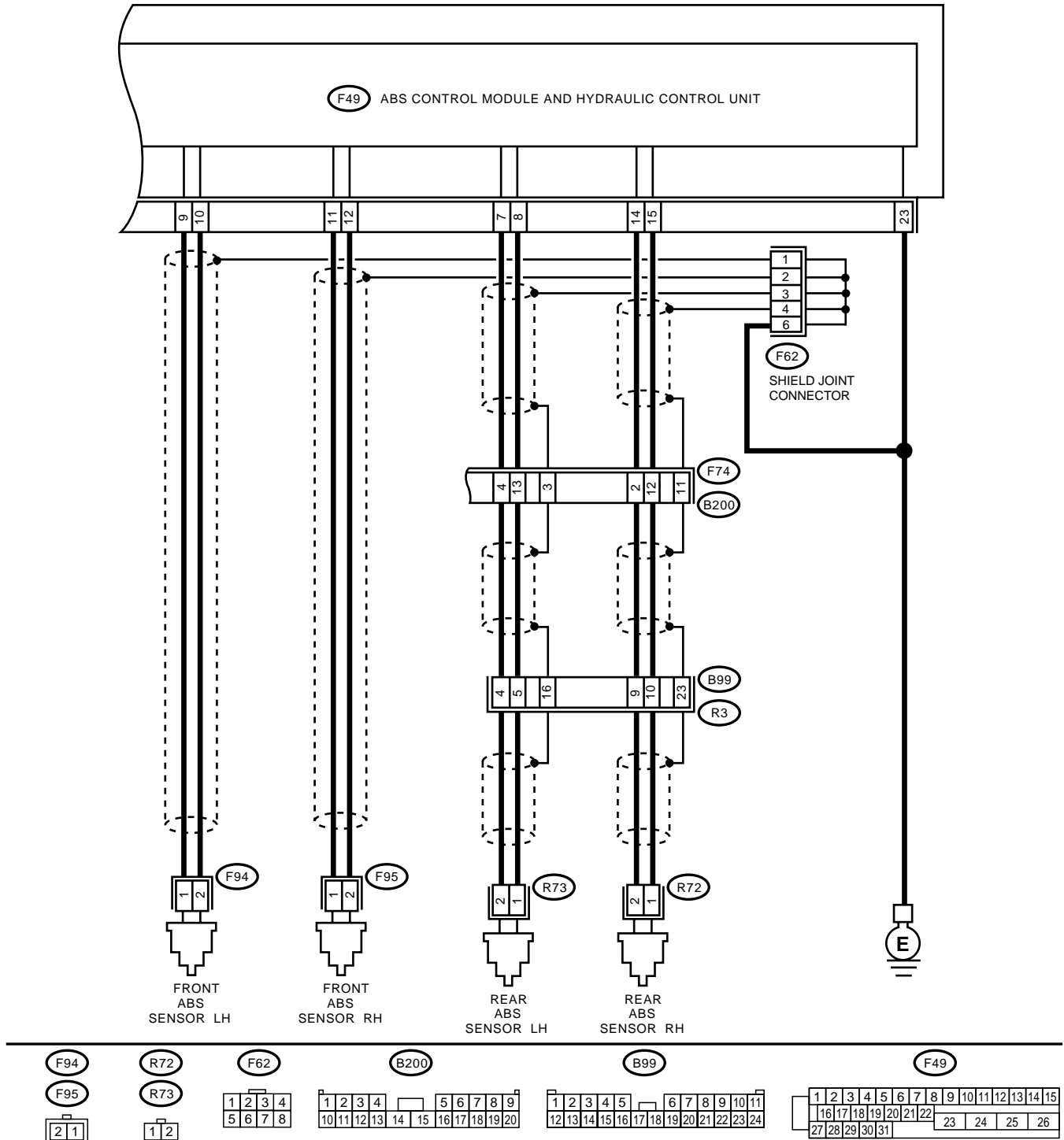

BR0037

DIAGNOSTICS CHART WITH SUBARU SELECT MONITOR

ABS (DIAGNOSTICS)

WIRING DIAGRAM: RHD MODEL

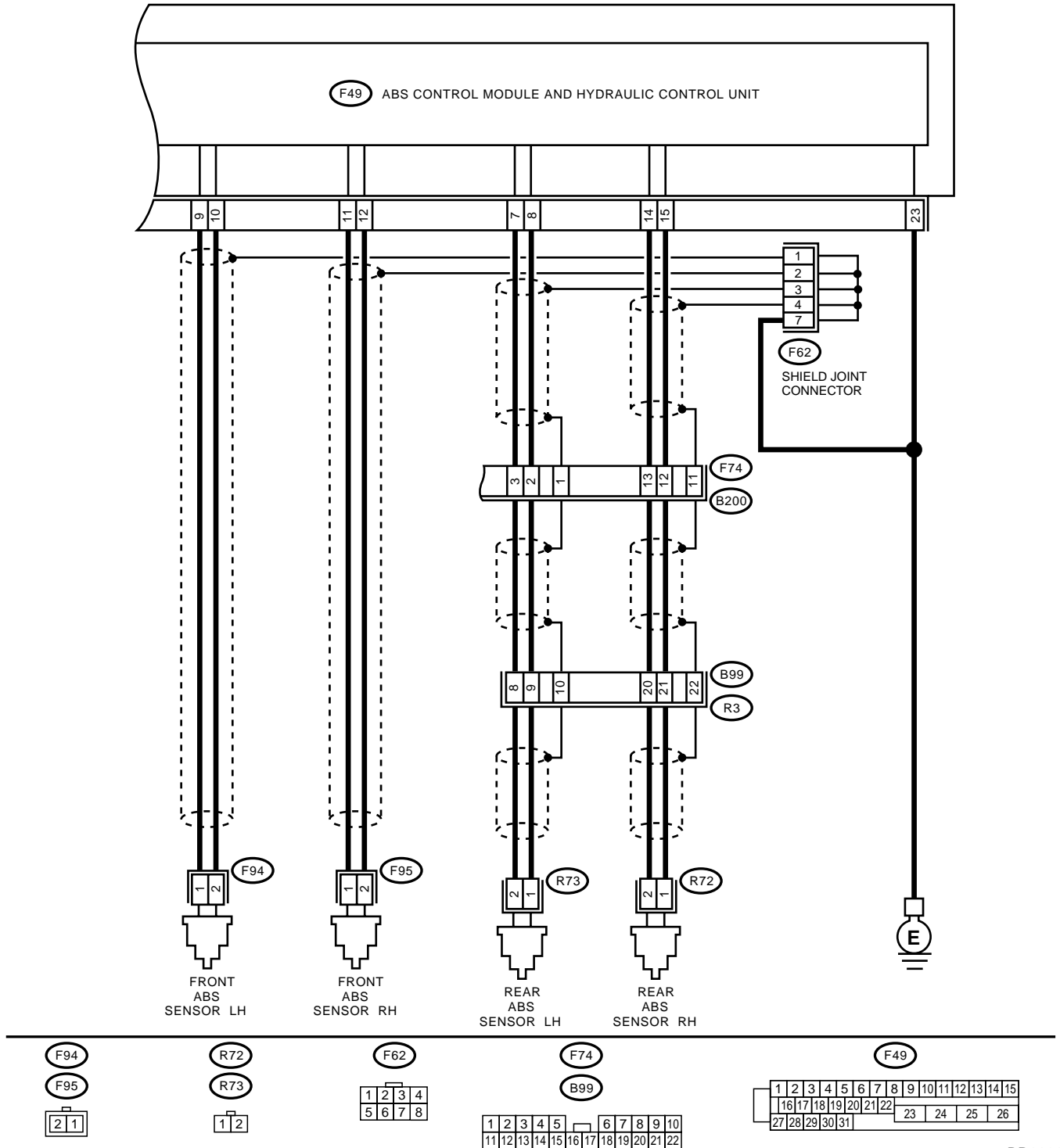

BR0038

DIAGNOSTICS CHART WITH SUBARU SELECT MONITOR

ABS (DIAGNOSTICS)

Step	Check	Yes	No	
1	CHECK OUTPUT OF ABS SENSOR USING SELECT MONITOR. 1) Select "Current data display & Save" on the select monitor. 2) Read the ABS sensor output corresponding to the faulty system in the select monitor data display mode.	Does the speed indicated on the display change in response to the speedometer reading during acceleration/deceleration when the steering wheel is in the straight-ahead position?	Go to step 2.	Go to step 8.
2	CHECK POOR CONTACT IN CONNECTORS. Turn ignition switch to OFF.	Is there poor contact in connectors between ABSCM&H/U and ABS sensor?	Repair connector.	Go to step 3.
3	CHECK SOURCES OF SIGNAL NOISE.	Is the car telephone or the wireless transmitter properly installed?	Go to step 4.	Properly install the car telephone or the wireless transmitter.
4	CHECK SOURCES OF SIGNAL NOISE.	Are noise sources (such as an antenna) installed near the sensor harness?	Install the noise sources apart from the sensor harness.	Go to step 5.
5	CHECK SHIELD CIRCUIT. 1) Turn ignition switch to OFF. 2) Connect all connectors. 3) Measure resistance between shield connector and chassis ground. Connector & terminal <i>Trouble code 26 / (B200) No. 11 — Chassis ground:</i> <i>Trouble code 28 / RHD: (B200) No. 1 — Chassis ground:</i> <i>Trouble code 28 / LHD: (B200) No. 3 — Chassis ground:</i> NOTE: For the Trouble code 22 and 24: Go to step 6.	Is the resistance less than 0.5 Ω?	Go to step 6.	Repair shield harness.
6	CHECK ABSCM&H/U. 1) Connect all connectors. 2) Erase the memory. 3) Perform inspection mode. 4) Read out the trouble code.	Is the same trouble code as in the current diagnosis still being output?	Replace ABSCM&H/U. <Ref. to ABS-7, ABS Control Module and Hydraulic Control Unit (ABSCM&H/U).>	Go to step 7.
7	CHECK ANY OTHER TROUBLE CODES APPEARANCE.	Are other trouble codes being output?	Proceed with the diagnosis corresponding to the trouble code.	A temporary noise interference.
8	CHECK INSTALLATION OF ABS SENSOR. Tightening torque: 32±10 N·m (3.3±1.0 kgf-m, 24±7 ft-lb)	Are the ABS sensor installation bolts tightened securely?	Go to step 9.	Tighten ABS sensor installation bolts securely.
9	CHECK ABS SENSOR GAP. Measure tone wheel to ABS sensor piece gap over entire perimeter of the wheel. Front wheel 0.3 — 0.8 mm (0.012 — 0.031 in) Rear wheel 0.7 — 1.2 mm (0.028 — 0.047 in)	Is the gap within the specifications?	Go to step 10.	Adjust the gap. NOTE: Adjust the gap using spacer (Part No. 26755AA000). If spacers cannot correct the gap, replace worn sensor or worn tone wheel.
10	PREPARE OSCILLOSCOPE.	Is an oscilloscope available?	Go to step 11.	Go to step 12.

DIAGNOSTICS CHART WITH SUBARU SELECT MONITOR

ABS (DIAGNOSTICS)

Step	Check	Yes	No
<p>11 CHECK ABS SENSOR SIGNAL. 1) Raise all four wheels of ground. 2) Turn ignition switch OFF. 3) Connect the oscilloscope to the connector. 4) Turn ignition switch ON. 5) Rotate wheels and measure voltage at specified frequency. <Ref. to ABS-17, WAVEFORM, Control Module I/O Signal.></p> <p>NOTE: When this inspection is completed, the ABS-CM&H/U sometimes stores the trouble code 29.</p> <p>Connector & terminal Trouble code 22 / (F95) No. 1 (+) — No. 2 (-): Trouble code 24 / (F94) No. 1 (+) — No. 2 (-): Trouble code 26 / LHD: (B99) No. 9 (+) — No. 10 (-): RHD: (B99) No. 20 (+) — No. 21 (-): Trouble code 28 / LHD: (B99) No. 4 (+) — No. 5 (-): RHD: (B99) No. 8 (+) — No. 9 (-):</p>	<p>Is oscilloscope pattern smooth, as shown in figure?</p>	<p>Go to step 15.</p>	<p>Go to step 12.</p>
<p>12 CHECK CONTAMINATION OF ABS SENSOR OR TONE WHEEL. Remove disc rotor or drum from hub in accordance with trouble code.</p>	<p>Is the ABS sensor piece or the tone wheel contaminated by dirt or other foreign matter?</p>	<p>Thoroughly remove dirt or other foreign matter.</p>	<p>Go to step 13.</p>
<p>13 CHECK DAMAGE OF ABS SENSOR OR TONE WHEEL.</p>	<p>Are there broken or damaged in the ABS sensor piece or the tone wheel?</p>	<p>Replace ABS sensor or tone wheel. Front: <Ref. to ABS-14, Front ABS Sensor.> Rear: <Ref. to ABS-17, Rear ABS Sensor.> and Front: <Ref. to ABS-20, Front Tone Wheel.> Rear: <Ref. to ABS-21, Rear Tone Wheel.></p>	<p>Go to step 14.</p>
<p>14 CHECK TONE WHEEL RUNOUT. Measure tone wheel runout.</p>	<p>Is the runout less than 0.05 mm (0.0020 in)?</p>	<p>Go to step 15.</p>	<p>Replace tone wheel. Front: <Ref. to ABS-20, Front Tone Wheel.> Rear: <Ref. to ABS-21, Rear Tone Wheel.></p>
<p>15 CHECK RESISTANCE OF ABS SENSOR. 1) Turn ignition switch OFF. 2) Disconnect connector from ABS sensor. 3) Measure resistance between ABS sensor connector terminals.</p> <p>Terminal Front RH No. 1 — No. 2: Front LH No. 1 — No. 2: Rear RH No. 1 — No. 2: Rear LH No. 1 — No. 2:</p>	<p>Is the resistance between 1 and 1.5 kΩ?</p>	<p>Go to step 16.</p>	<p>Replace ABS sensor. Front: <Ref. to ABS-14, Front ABS Sensor.> Rear: <Ref. to ABS-17, Rear ABS Sensor.></p>

DIAGNOSTICS CHART WITH SUBARU SELECT MONITOR

ABS (DIAGNOSTICS)

Step	Check	Yes	No
16 CHECK GROUND SHORT OF ABS SENSOR. Measure resistance between ABS sensor and chassis ground. <i>Terminal</i> <i>Front RH No. 1 — Chassis ground:</i> <i>Front LH No. 1 — Chassis ground:</i> <i>Rear RH No. 1 — Chassis ground:</i> <i>Rear LH No. 1 — Chassis ground:</i>	Is the resistance more than 1 M Ω ?	Go to step 17.	Replace ABS sensor. Front: <Ref. to ABS-14, Front ABS Sensor.> Rear: <Ref. to ABS-17, Rear ABS Sensor.>
17 CHECK HARNESS/CONNECTOR BETWEEN ABSCM&H/U AND ABS SENSOR. 1)Connect connector to ABS sensor. 2)Disconnect connector from ABSCM&H/U. 3)Measure resistance at ABSCM&H/U connector terminals. <i>Connector & terminal</i> <i>Trouble code 22 / (F49) No. 11 — No. 12:</i> <i>Trouble code 24 / (F49) No. 9 — No. 10:</i> <i>Trouble code 26 / (F49) No. 14 — No. 15:</i> <i>Trouble code 28 / (F49) No. 7 — No. 8:</i>	Is the resistance between 1 and 1.5 k Ω ?	Go to step 18.	Repair harness/connector between ABSCM&H/U and ABS sensor.
18 CHECK GROUND SHORT OF HARNESS. Measure resistance between ABSCM&H/U connector and chassis ground. <i>Connector & terminal</i> <i>Trouble code 22 / (F49) No. 11 — Chassis ground:</i> <i>Trouble code 24 / (F49) No. 9 — Chassis ground:</i> <i>Trouble code 26 / (F49) No. 14 — Chassis ground:</i> <i>Trouble code 28 / (F49) No. 7 — Chassis ground:</i>	Is the resistance more than 1 M Ω ?	Go to step 19.	Repair harness/connector between ABSCM&H/U and ABS sensor.
19 CHECK GROUND CIRCUIT OF ABSCM&H/U. Measure resistance between ABSCM&H/U and chassis ground. <i>Connector & terminal</i> <i>(F49) No. 23 — GND:</i>	Is the resistance less than 0.5 Ω ?	Go to step 20.	Repair ABSCM&H/U ground harness.
20 CHECK POOR CONTACT IN CONNECTORS.	Is there poor contact in connectors between ABSCM&H/U and ABS sensor?	Repair connector.	Go to step 21.
21 CHECK SOURCES OF SIGNAL NOISE.	Is the car telephone or the wireless transmitter properly installed?	Go to step 22.	Properly install the car telephone or the wireless transmitter.
22 CHECK SOURCES OF SIGNAL NOISE.	Are noise sources (such as an antenna) installed near the sensor harness?	Install the noise sources apart from the sensor harness.	Go to step 23.

DIAGNOSTICS CHART WITH SUBARU SELECT MONITOR

ABS (DIAGNOSTICS)

Step	Check	Yes	No
23 CHECK SHIELD CIRCUIT. 1)Connect all connectors. 2)Measure resistance between shield connector and chassis ground. Connector & terminal Trouble code 26 / (B200) No. 11 — Chassis ground: Trouble code 28 / RHD: (B200) No. 1 — Chassis ground: Trouble code 28 / LHD: (B200) No. 3 — Chassis ground: NOTE: For the Trouble code 22 and 24 : Go to step 24 .	Is the resistance less than 0.5 Ω?	Go to step 24 .	Repair shield harness.
24 CHECK ABSCM&H/U. 1)Connect all connectors. 2)Erase the memory. 3)Perform inspection mode. 4)Read out the trouble code.	Is the same trouble code as in the current diagnosis still being output?	Replace ABSCM&H/U. <Ref. to ABS-7, ABS Control Module and Hydraulic Control Unit (ABSCM&H/U).>	Go to step 25 .
25 CHECK ANY OTHER TROUBLE CODES APPEARANCE.	Are other trouble codes being output?	Proceed with the diagnosis corresponding to the trouble code.	A temporary noise interference.

DIAGNOSTICS CHART WITH SUBARU SELECT MONITOR

ABS (DIAGNOSTICS)

K: TROUBLE CODE 29

— ABNORMAL ABS SENSOR SIGNAL ON ANY ONE OF FOUR SENSOR —

DIAGNOSIS:

- Faulty ABS sensor signal (noise, irregular signal, etc.)
- Faulty tone wheel
- Wheels turning freely for a long time

TROUBLE SYMPTOM:

- ABS does not operate.

WIRING DIAGRAM: LHD MODEL

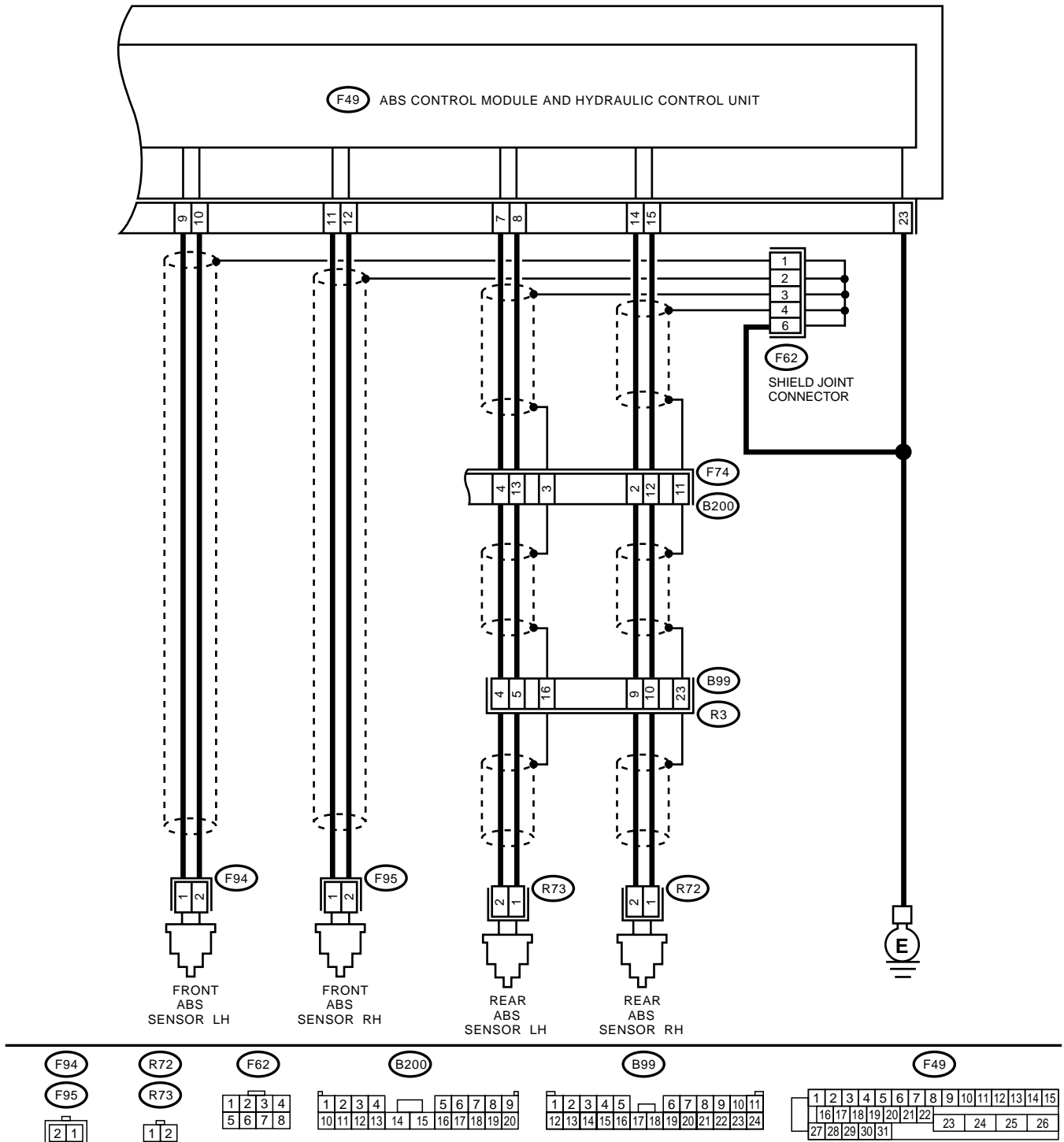

BR0037

DIAGNOSTICS CHART WITH SUBARU SELECT MONITOR

ABS (DIAGNOSTICS)

WIRING DIAGRAM: RHD MODEL

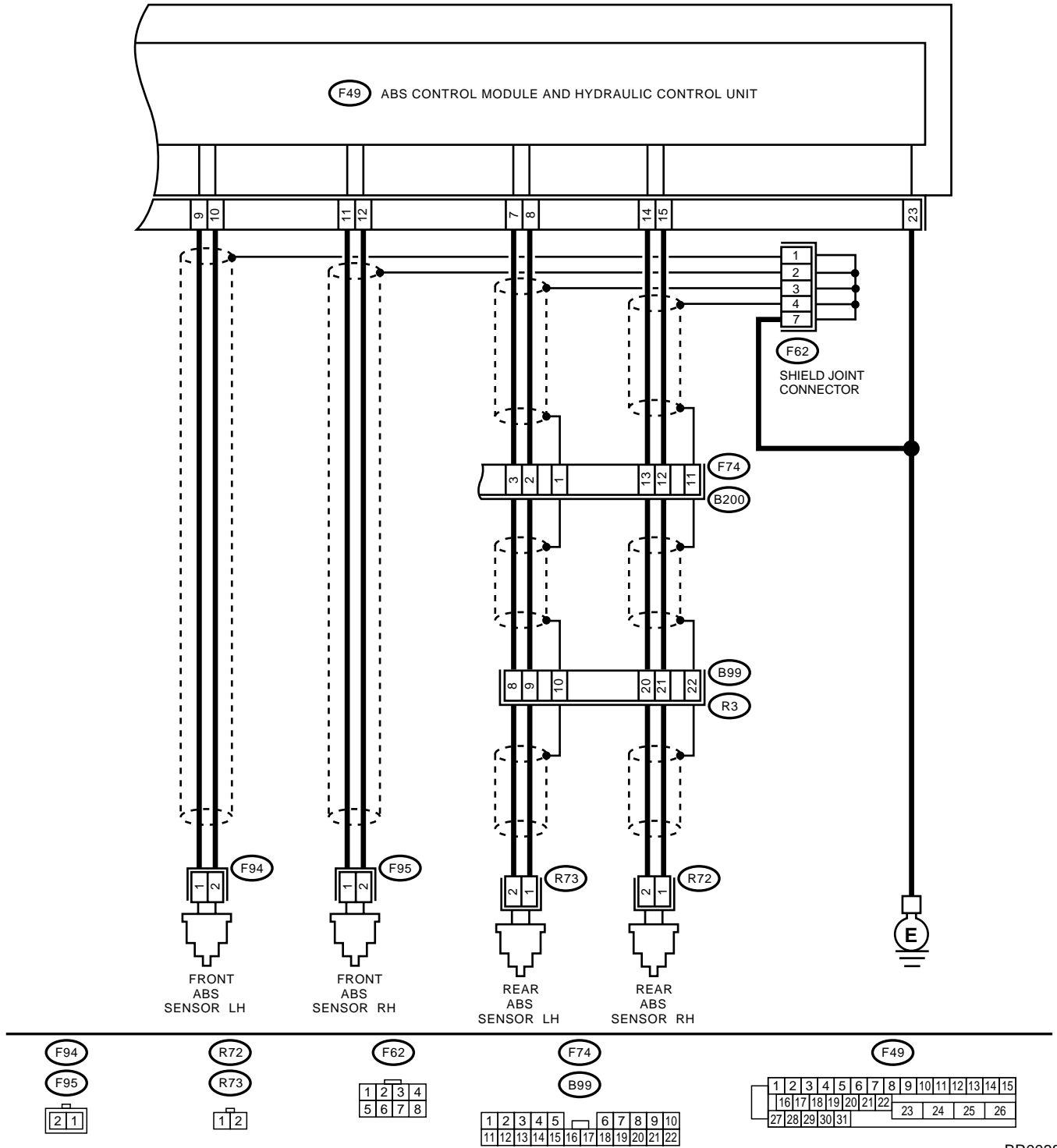

BR0038

DIAGNOSTICS CHART WITH SUBARU SELECT MONITOR

ABS (DIAGNOSTICS)

Step	Check	Yes	No
1	CHECK IF THE WHEELS HAVE TURNED FREELY FOR A LONG TIME.	Check if the wheels have been turned freely for more than one minute, such as when the vehicle is jacked-up, under full-lock cornering or when tire is not in contact with road surface.	The ABS is normal. Erase the trouble code. NOTE: When the wheels turn freely for a long time, such as when the vehicle is towed or jacked-up, or when steering wheel is continuously turned all the way, this trouble code may sometimes occur.
2	CHECK TIRE SPECIFICATIONS. Turn ignition switch to OFF.	Are the tire specifications correct?	Go to step 3 . Replace tire.
3	CHECK WEAR OF TIRE.	Is the tire worn excessively?	Replace tire. Go to step 4 .
4	CHECK TIRE PRESSURE.	Is the tire pressure correct?	Go to step 5 . Adjust tire pressure.
5	CHECK INSTALLATION OF ABS SENSOR. <i>Tightening torque:</i> 32±10 N·m (3.3±1.0 kgf·m, 24±7 ft·lb)	Are the ABS sensor installation bolts tightened securely?	Go to step 6 . Tighten ABS sensor installation bolts securely.
6	CHECK ABS SENSOR GAP. Measure tone wheel to ABS sensor piece gap over entire perimeter of the wheel. <i>Front wheel</i> 0.3 — 0.8 mm (0.012 — 0.031 in) <i>Rear wheel</i> 0.7 — 1.2 mm (0.028 — 0.047 in)	Is the gap within the specifications?	Go to step 7 . Adjust the gap. NOTE: Adjust the gap using spacer (Part No. 26755AA000). If spacers cannot correct the gap, replace worn sensor or worn tone wheel.
7	PREPARE OSCILLOSCOPE.	Is an oscilloscope available?	Go to step 8 . Go to step 9 .
8	CHECK ABS SENSOR SIGNAL. 1) Raise all four wheels of ground. 2) Turn ignition switch OFF. 3) Connect the oscilloscope to the connector (B99), (F95) or (F94) in accordance with trouble code. 4) Turn ignition switch ON. 5) Rotate wheels and measure voltage at specified frequency. <Ref. to ABS-17, WAVEFORM, Control Module I/O Signal.> NOTE: When this inspection is completed, the ABS-CM&H/U sometimes stores the trouble code 29. Connector & terminal <i>Front RH</i> (F95) No. 1 (+) — No. 2 (-): <i>Front LH</i> (F94) No. 1 (+) — No. 2 (-): <i>Rear RH</i> LHD: (B99) No. 9 (+) — No. 10 (-): RHD: (B99) No. 20 (+) — No. 21 (-): <i>Rear LH</i> LHD: (B99) No. 4 (+) — No. 5 (-): RHD: (B99) No. 8 (+) — No. 9 (-):	Is oscilloscope pattern smooth, as shown in figure?	Go to step 12 . Go to step 9 .

DIAGNOSTICS CHART WITH SUBARU SELECT MONITOR

ABS (DIAGNOSTICS)

Step	Check	Yes	No
9 CHECK CONTAMINATION OF ABS SENSOR OR TONE WHEEL. Remove disc rotor from hub.	Is the ABS sensor piece or the tone wheel contaminated by dirt or other foreign matter?	Thoroughly remove dirt or other foreign matter.	Go to step 10 .
10 CHECK DAMAGE OF ABS SENSOR OR TONE WHEEL.	Are there broken or damaged teeth in the ABS sensor piece or the tone wheel?	Replace ABS sensor or tone wheel. Front: <Ref. to ABS-14, Front ABS Sensor.> Rear: <Ref. to ABS-17, Rear ABS Sensor.> and Front: <Ref. to ABS-20, Front Tone Wheel.> Rear: <Ref. to ABS-21, Rear Tone Wheel.>	Go to step 11 .
11 CHECK TONE WHEEL RUNOUT. Measure tone wheel runout.	Is the runout less than 0.05 mm (0.0020 in)?	Go to step 12 .	Replace tone wheel. Front: <Ref. to ABS-20, Front Tone Wheel.> Rear: <Ref. to ABS-21, Rear Tone Wheel.>
12 CHECK ABSCM&H/U. 1)Turn ignition switch to OFF. 2)Connect all connectors. 3)Erase the memory. 4)Perform inspection mode. 5)Read out the trouble code.	Is the same trouble code as in the current diagnosis still being output?	Replace ABSCM&H/U. <Ref. to ABS-7, ABS Control Module and Hydraulic Control Unit (ABSCM&H/U).>	Go to step 13 .
13 CHECK ANY OTHER TROUBLE CODES APPEARANCE.	Are other trouble codes being output?	Proceed with the diagnosis corresponding to the trouble code.	A temporary poor contact.

DIAGNOSTICS CHART WITH SUBARU SELECT MONITOR

ABS (DIAGNOSTICS)

L: TROUBLE CODE 31 **— FRONT RIGHT INLET VALVE MALFUNCTION —**

NOTE:

For the diagnostic procedure, refer to TROUBLE CODE 37. <Ref. to ABS-126, TROUBLE CODE 37 — REAR LEFT INLET VALVE MALFUNCTION —, Diagnostics Chart with Subaru Select Monitor.>

M: TROUBLE CODE 33 **— FRONT LEFT INLET VALVE MALFUNCTION —**

NOTE:

For the diagnostic procedure, refer to TROUBLE CODE 37. <Ref. to ABS-126, TROUBLE CODE 37 — REAR LEFT INLET VALVE MALFUNCTION —, Diagnostics Chart with Subaru Select Monitor.>

N: TROUBLE CODE 35 **— REAR RIGHT INLET VALVE MALFUNCTION —**

NOTE:

For the diagnostic procedure, refer to TROUBLE CODE 37. <Ref. to ABS-126, TROUBLE CODE 37 — REAR LEFT INLET VALVE MALFUNCTION —, Diagnostics Chart with Subaru Select Monitor.>

DIAGNOSTICS CHART WITH SUBARU SELECT MONITOR

ABS (DIAGNOSTICS)

DIAGNOSTICS CHART WITH SUBARU SELECT MONITOR

ABS (DIAGNOSTICS)

O: TROUBLE CODE 37 — REAR LEFT INLET VALVE MALFUNCTION —

DIAGNOSIS:

- Faulty harness/connector
- Faulty inlet solenoid valve

TROUBLE SYMPTOM:

- ABS does not operate.

WIRING DIAGRAM:

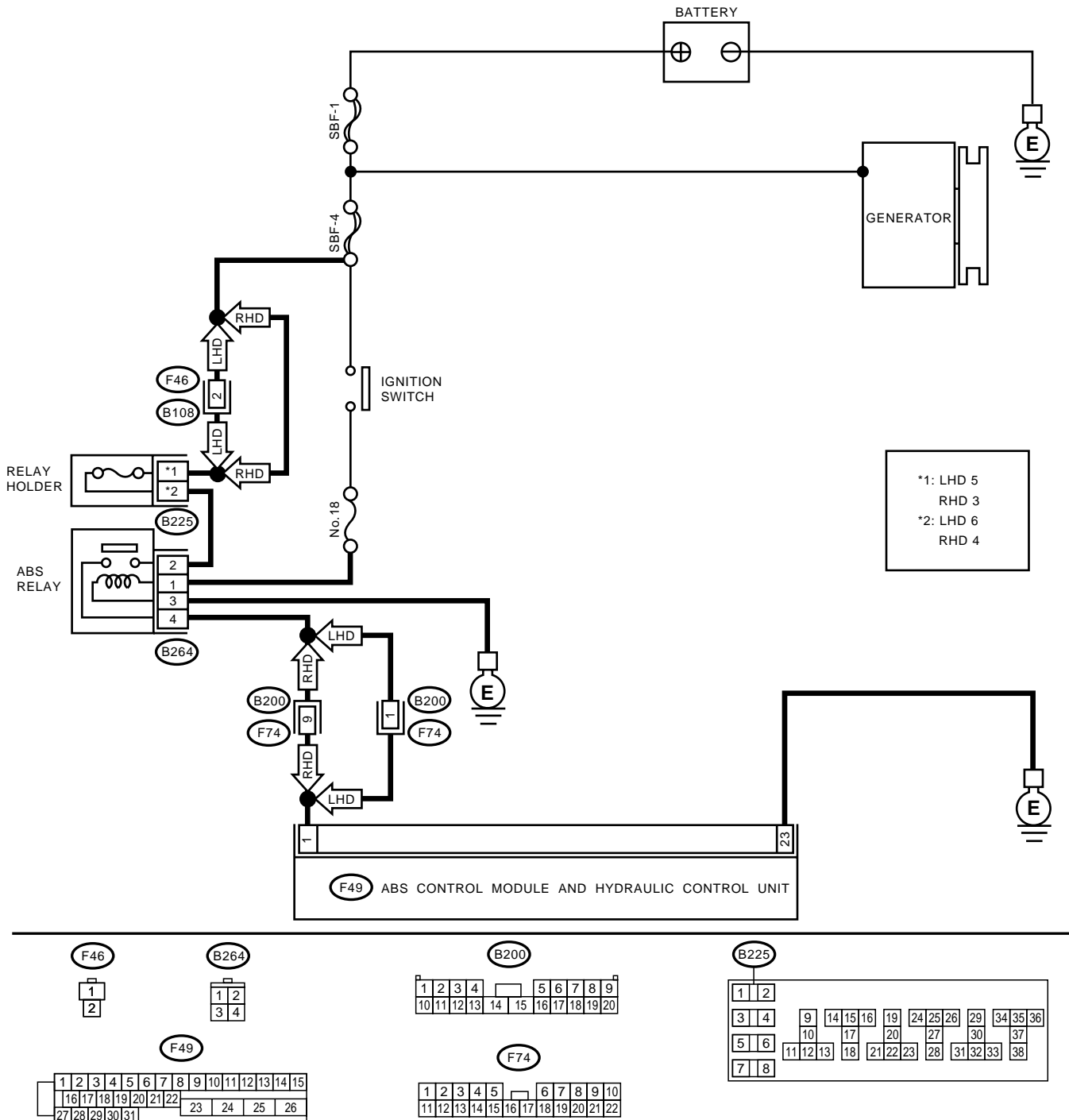

DIAGNOSTICS CHART WITH SUBARU SELECT MONITOR

ABS (DIAGNOSTICS)

Step	Check	Yes	No
1 CHECK INPUT VOLTAGE OF RELAY HOLDER. 1) Turn ignition switch to OFF. 2) Remove fuse. 3) Measure voltage between ABS relay connector and chassis ground. <i>Connector & terminal</i> <i>LHD model</i> (B225) No. 5 (+) — Chassis ground (-): <i>RHD model</i> (B225) No. 3 (+) — Chassis ground (-):	Is the voltage more than 10 V?	Go to step 2.	Repair open circuit in harness between battery and Relay holder connector.
2 CHECK RELAY HOLDER.	Is the fuse blown out?	Replace fuse.	Go to step 3.
3 CHECK INPUT VOLTAGE OF ABS RELAY. 1) Install fuse. 2) Remove ABS relay. 3) Turn ignition switch to ON. 4) Measure voltage between ABS relay connector and chassis ground. <i>Connector & terminal</i> (B264) No. 2 (+) — Chassis ground (-):	Is the voltage more than 10 V?	Go to step 4.	Repair open circuit in harness between battery and Relay holder connector.
4 CHECK INPUT VOLTAGE OF ABS RELAY. Measure voltage between ABS relay connector and chassis ground. <i>Connector & terminal</i> (B264) No. 1 (+) — Chassis ground (-):	Is the voltage more than 10 V?	Go to step 5.	Repair harness connector between battery, ignition switch and ABS relay.
5 CHECK GROUND CIRCUIT OF ABS RELAY. 1) Turn ignition switch to OFF. 2) Measure resistance between ABS relay connector and chassis ground. <i>Connector & terminal</i> (B264) No. 3 (+) — Chassis ground:	Is the resistance less than 5 Ω ?	Go to step 6.	Repair open circuit between ABS relay and chassis ground.
6 CHECK ABS RELAY. 1) Connect battery to ABS relay terminal No. 1 and 3. 2) Measure resistance between ABS relay terminals.	Is the resistance less than 10 Ω ?	Go to step 7.	Replace ABS relay.
7 CHECK INPUT VOLTAGE OF ABSCM&H/U. 1) Turn ignition switch to OFF. 2) Disconnect connector from ABSCM&H/U. 3) Run the engine at idle. 4) Measure voltage between ABSCM&H/U connector and chassis ground. <i>Connector & terminal</i> (F49) No. 1 (+) — Chassis ground (-):	Is the voltage between 10 and 15 V?	Go to step 8.	Repair harness connector between battery, ignition switch and ABSCM&H/U.
8 CHECK GROUND CIRCUIT OF ABSCM&H/U. 1) Turn ignition switch to OFF. 2) Measure resistance between ABSCM&H/U connector and chassis ground. <i>Connector & terminal</i> (F49) No. 23 — Chassis ground:	Is the resistance less than 0.5 Ω ?	Go to step 9.	Repair ABSCM&H/U ground harness.
9 CHECK POOR CONTACT IN CONNECTORS.	Is there poor contact in connectors between generator, battery and ABSCM&H/U?	Repair connector.	Go to step 10.

DIAGNOSTICS CHART WITH SUBARU SELECT MONITOR

ABS (DIAGNOSTICS)

Step	Check	Yes	No
10 CHECK ABSCM&H/U. 1)Connect all connectors. 2)Erase the memory. 3)Perform inspection mode. 4)Read out the trouble code.	Is the same trouble code as in the current diagnosis still being output?	Replace ABSCM&H/U. <Ref. to ABS-7, ABS Control Module and Hydraulic Control Unit (ABSCM&H/U).>	Go to step 11.
11 CHECK ANY OTHER TROUBLE CODES APPEARANCE.	Are other trouble codes being output?	Proceed with the diagnosis corresponding to the trouble code.	A temporary poor contact.

P: TROUBLE CODE 32
— FRONT RIGHT OUTLET VALVE MALFUNCTION —

NOTE:

For the diagnostic procedure, refer to TROUBLE CODE 38. <Ref. to ABS-130, TROUBLE CODE 38 — REAR LEFT OUTLET VALVE MALFUNCTION —, Diagnostics Chart with Subaru Select Monitor.>

Q: TROUBLE CODE 34
— FRONT LEFT OUTLET VALVE MALFUNCTION —

NOTE:

For the diagnostic procedure, refer to TROUBLE CODE 38. <Ref. to ABS-130, TROUBLE CODE 38 — REAR LEFT OUTLET VALVE MALFUNCTION —, Diagnostics Chart with Subaru Select Monitor.>

R: TROUBLE CODE 36
— REAR RIGHT OUTLET VALVE MALFUNCTION —

NOTE:

For the diagnostic procedure, refer to TROUBLE CODE 38. <Ref. to ABS-130, TROUBLE CODE 38 — REAR LEFT OUTLET VALVE MALFUNCTION —, Diagnostics Chart with Subaru Select Monitor.>

DIAGNOSTICS CHART WITH SUBARU SELECT MONITOR

ABS (DIAGNOSTICS)

S: TROUBLE CODE 38 — REAR LEFT OUTLET VALVE MALFUNCTION —

DIAGNOSIS:

- Faulty harness/connector
- Faulty outlet solenoid valve

TROUBLE SYMPTOM:

- ABS does not operate.

WIRING DIAGRAM:

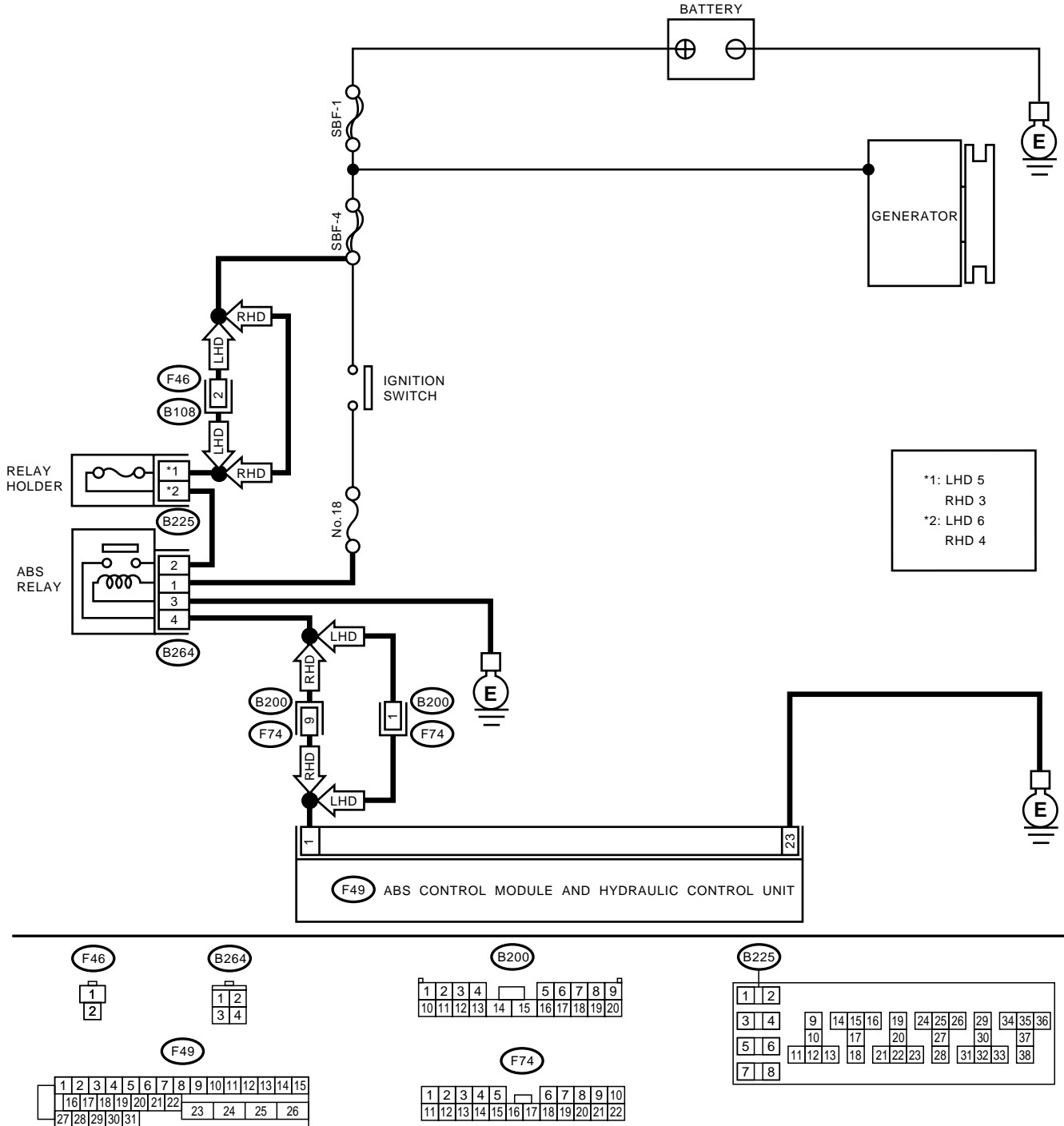

BR0039

DIAGNOSTICS CHART WITH SUBARU SELECT MONITOR

ABS (DIAGNOSTICS)

Step	Check	Yes	No
1 CHECK INPUT VOLTAGE OF RELAY HOLDER. 1) Turn ignition switch to OFF. 2) Remove fuse. 3) Measure voltage between ABS relay connector and chassis ground. Connector & terminal <i>LHD model</i> (B225) No. 5 (+) — Chassis ground (-): <i>RHD model</i> (B225) No. 3 (+) — Chassis ground (-):	Is the voltage more than 10 V?	Go to step 2.	Repair open circuit in harness between battery and Relay holder connector.
2 CHECK RELAY HOLDER.	Is the fuse blown out?	Replace fuse.	Go to step 3.
3 CHECK INPUT VOLTAGE OF ABS RELAY. 1) Install fuse. 2) Remove ABS relay. 3) Turn ignition switch to ON. 4) Measure voltage between ABS relay connector and chassis ground. Connector & terminal (B264) No. 2 (+) — Chassis ground (-):	Is the voltage more than 10 V?	Go to step 4.	Repair open circuit in harness between battery and Relay holder connector.
4 CHECK INPUT VOLTAGE OF ABS RELAY. Measure voltage between ABS relay connector and chassis ground. Connector & terminal (B264) No. 1 (+) — Chassis ground (-):	Is the voltage more than 10 V?	Go to step 5.	Repair harness connector between battery, ignition switch and ABS relay.
5 CHECK GROUND CIRCUIT OF ABS RELAY. 1) Turn ignition switch to OFF. 2) Measure resistance between ABS relay connector and chassis ground. Connector & terminal (B264) No. 3 (+) — Chassis ground:	Is the resistance less than 5 Ω ?	Go to step 6.	Repair open circuit between ABS relay and chassis ground.
6 CHECK ABS RELAY. 1) Connect battery to ABS relay terminal No. 1 and 3. 2) Measure resistance between ABS relay terminals.	Is the resistance less than 10 Ω ?	Go to step 7.	Replace ABS relay.
7 CHECK INPUT VOLTAGE OF ABSCM&H/U. 1) Turn ignition switch to OFF. 2) Disconnect connector from ABSCM&H/U. 3) Run the engine at idle. 4) Measure voltage between ABSCM&H/U connector and chassis ground. Connector & terminal (F49) No. 1 (+) — Chassis ground (-):	Is the voltage between 10 and 15 V?	Go to step 8.	Repair harness connector between battery, ignition switch and ABSCM&H/U.
8 CHECK GROUND CIRCUIT OF ABSCM&H/U. 1) Turn ignition switch to OFF. 2) Measure resistance between ABSCM&H/U connector and chassis ground. Connector & terminal (F49) No. 23 — Chassis ground:	Is the resistance less than 0.5 Ω ?	Go to step 9.	Repair ABSCM&H/U ground harness.
9 CHECK POOR CONTACT IN CONNECTORS.	Is there poor contact in connectors between generator, battery and ABSCM&H/U?	Repair connector.	Go to step 10.

DIAGNOSTICS CHART WITH SUBARU SELECT MONITOR

ABS (DIAGNOSTICS)

	Step	Check	Yes	No
10	CHECK ABSCM&H/U. 1)Connect all connectors. 2)Erase the memory. 3)Perform inspection mode. 4)Read out the trouble code.	Is the same trouble code as in the current diagnosis still being output?	Replace ABSCM&H/U. <Ref. to ABS-7, ABS Control Module and Hydraulic Control Unit (ABSCM&H/U).>	Go to step 11.
11	CHECK ANY OTHER TROUBLE CODES APPEARANCE.	Are other trouble codes being output?	Proceed with the diagnosis corresponding to the trouble code.	A temporary poor contact.

DIAGNOSTICS CHART WITH SUBARU SELECT MONITOR

ABS (DIAGNOSTICS)

T: TROUBLE CODE 41 — ABS CONTROL MODULE MALFUNCTION —

DIAGNOSIS:

- Faulty ABSCM&H/U

TROUBLE SYMPTOM:

- ABS does not operate.

WIRING DIAGRAM:

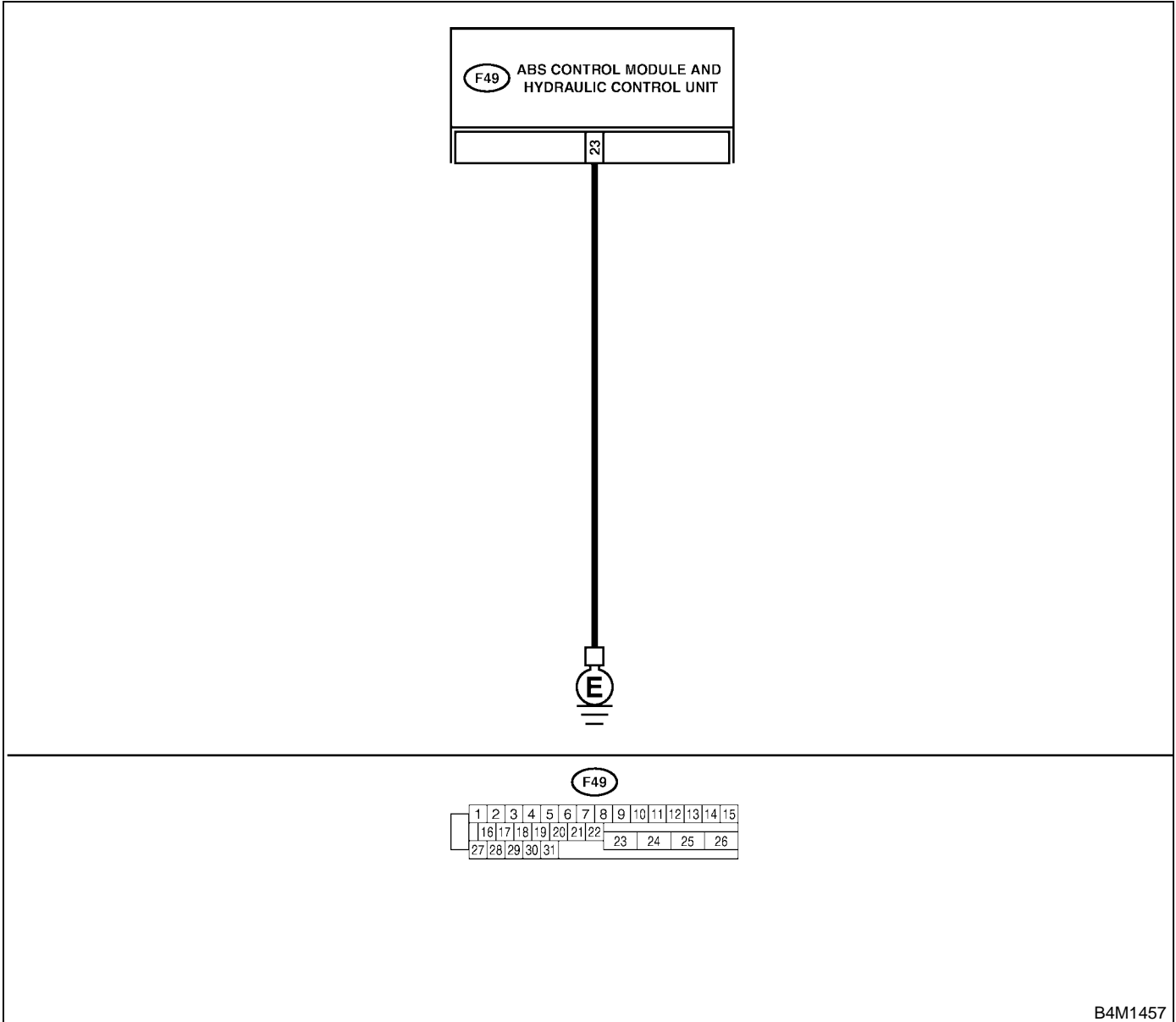

B4M1457

DIAGNOSTICS CHART WITH SUBARU SELECT MONITOR

ABS (DIAGNOSTICS)

Step	Check	Yes	No
1 CHECK GROUND CIRCUIT OF ABSCM&H/U. 1) Turn ignition switch to OFF. 2) Disconnect connector from ABSCM&H/U. 3) Measure resistance between ABSCM&H/U and chassis ground. <i>Connector & terminal (F49) No. 23 — Chassis ground:</i>	Is the resistance less than 0.5 Ω ?	Go to step 2.	Repair ABSCM&H/U ground harness.
2 CHECK POOR CONTACT IN CONNECTORS.	Is there poor contact in connectors between battery, ignition switch and ABSCM&H/U?	Repair connector.	Go to step 3.
3 CHECK SOURCES OF SIGNAL NOISE.	Is the car telephone or the wireless transmitter properly installed?	Go to step 4.	Properly install the car telephone or the wireless transmitter.
4 CHECK SOURCES OF SIGNAL NOISE.	Are noise sources (such as an antenna) installed near the sensor harness?	Install the noise sources apart from the sensor harness.	Go to step 5.
5 CHECK ABSCM&H/U. 1) Turn ignition switch to OFF. 2) Connect all connectors. 3) Erase the memory. 4) Perform inspection mode. 5) Read out the trouble code.	Is the same trouble code as in the current diagnosis still being output?	Replace ABSCM&H/U. <Ref. to ABS-7, ABS Control Module and Hydraulic Control Unit (ABSCM&H/U).>	Go to step 6.
6 CHECK ANY OTHER TROUBLE CODES APPEARANCE.	Are other trouble codes being output?	Proceed with the diagnosis corresponding to the trouble code.	A temporary poor contact.

DIAGNOSTICS CHART WITH SUBARU SELECT MONITOR

ABS (DIAGNOSTICS)

U: TROUBLE CODE 42 — POWER SUPPLY VOLTAGE TOO LOW —

DIAGNOSIS:

- Power source voltage of the ABSCM&H/U is low.

TROUBLE SYMPTOM:

- ABS does not operate.

WIRING DIAGRAM:

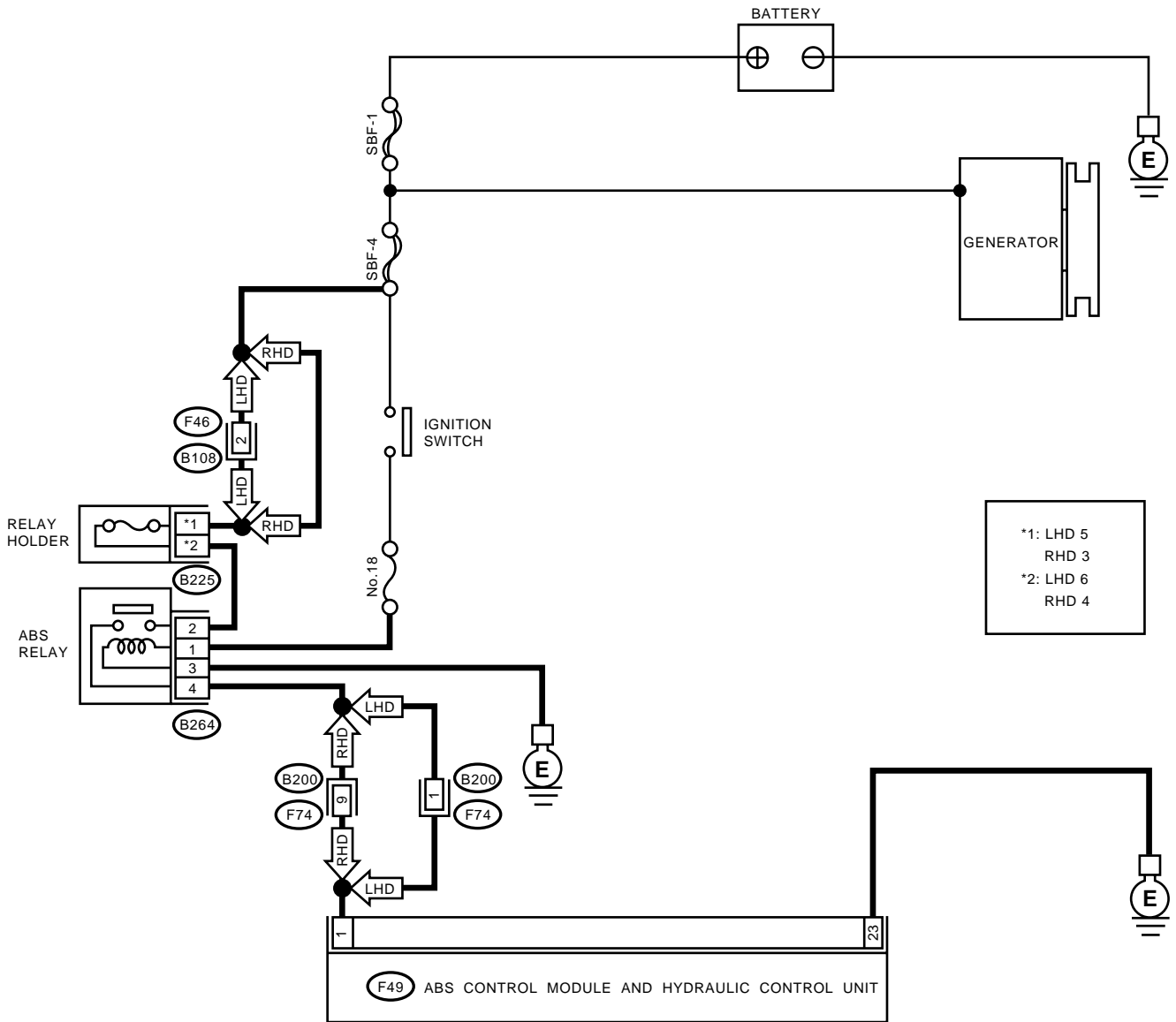

*1: LHD 5
RHD 3
*2: LHD 6
RHD 4

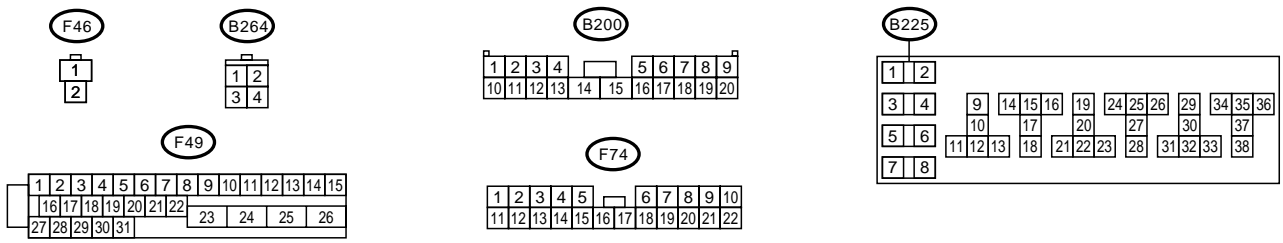

BR0039

DIAGNOSTICS CHART WITH SUBARU SELECT MONITOR

ABS (DIAGNOSTICS)

Step	Check	Yes	No
1 CHECK GENERATOR. 1)Start engine. 2)Idling after warm-up. 3)Measure voltage between generator B terminal and chassis ground. <i>Terminal</i> <i>Generator B terminal — Chassis ground:</i>	Is the voltage between 10 and 15 V?	Go to step 2.	Repair generator. <Ref. to SC-12, Generator.>
2 CHECK BATTERY TERMINAL. Turn ignition switch to OFF.	Are the positive and negative battery terminals tightly clamped?	Go to step 3.	Tighten the clamp of terminal.
3 CHECK INPUT VOLTAGE OF ABSCM&H/U. 1)Disconnect connector from ABSCM&H/U. 2)Run the engine at idle. 3)Measure voltage between ABSCM&H/U connector and chassis ground. <i>Connector & terminal</i> <i>(F49) No. 1 (+) — Chassis ground (-):</i>	Is the voltage between 10 and 15 V?	Go to step 4.	Repair harness connector between battery, ignition switch and ABSCM&H/U.
4 CHECK GROUND CIRCUIT OF ABSCM&H/U. 1)Turn ignition switch to OFF. 2)Measure resistance between ABSCM&H/U connector and chassis ground. <i>Connector & terminal</i> <i>(F49) No. 23 — Chassis ground:</i>	Is the resistance less than 0.5 Ω?	Go to step 5.	Repair ABSCM&H/U ground harness.
5 CHECK POOR CONTACT IN CONNECTORS.	Is there poor contact in connectors between generator, battery and ABSCM&H/U?	Repair connector.	Go to step 6.
6 CHECK ABSCM&H/U. 1)Connect all connectors. 2)Erase the memory. 3)Perform inspection mode. 4)Read out the trouble code.	Is the same trouble code as in the current diagnosis still being output?	Replace ABSCM&H/U. <Ref. to ABS-7, ABS Control Module and Hydraulic Control Unit (ABSCM&H/U).>	Go to step 7.
7 CHECK ANY OTHER TROUBLE CODES APPEARANCE.	Are other trouble codes being output?	Proceed with the diagnosis corresponding to the trouble code.	A temporary poor contact.

DIAGNOSTICS CHART WITH SUBARU SELECT MONITOR

ABS (DIAGNOSTICS)

V: TROUBLE CODE 42 — POWER SUPPLY VOLTAGE TOO HIGH —

DIAGNOSIS:

- Power source voltage of the ABSCM&H/U is high.

TROUBLE SYMPTOM:

- ABS does not operate.

WIRING DIAGRAM:

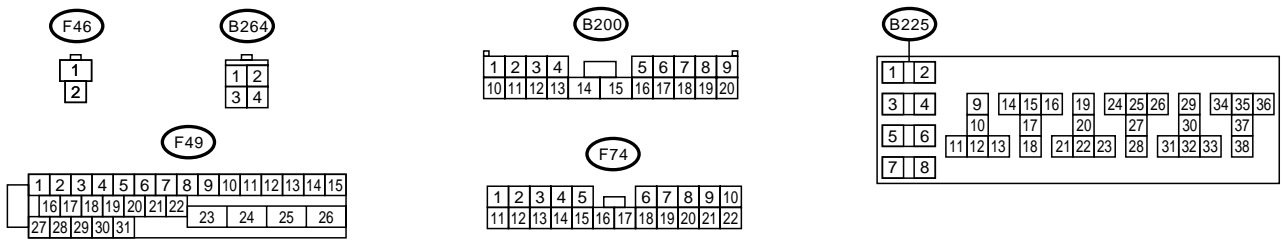
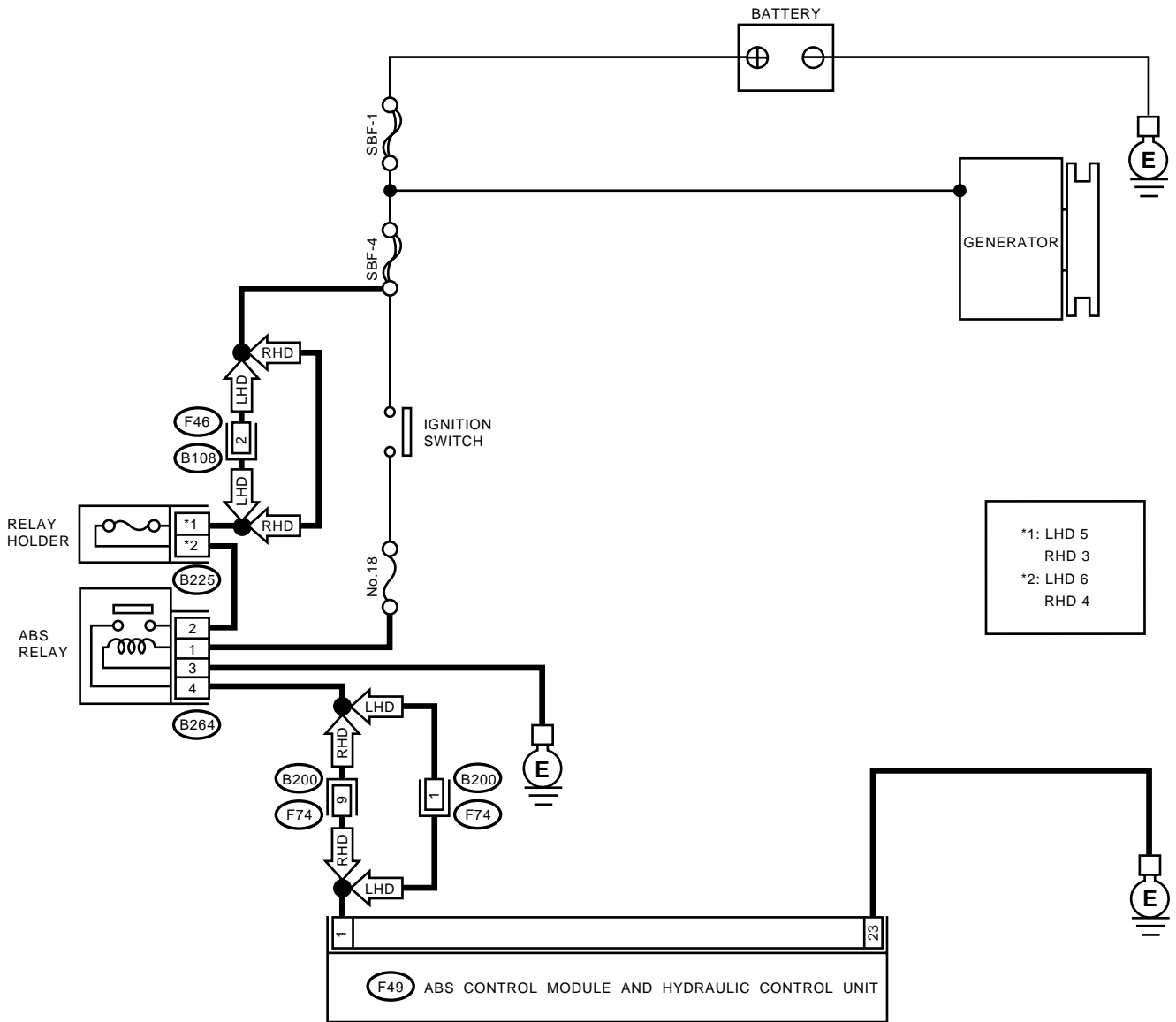

BR0039

DIAGNOSTICS CHART WITH SUBARU SELECT MONITOR

ABS (DIAGNOSTICS)

Step	Check	Yes	No
1 CHECK GENERATOR. 1)Start engine. 2)Idling after warm-up. 3)Measure voltage between generator B terminal and chassis ground. <i>Terminal</i> <i>Generator B terminal — Chassis ground:</i>	Is the voltage between 10 and 17 V?	Go to step 2.	Repair generator. <Ref. to SC-12, Generator.>
2 CHECK BATTERY TERMINAL. Turn ignition switch to OFF.	Are the positive and negative battery terminals tightly clamped?	Go to step 3.	Tighten the clamp of terminal.
3 CHECK INPUT VOLTAGE OF RELAY HOLDER. 1)Turn ignition switch to OFF. 2)Remove fuse. 3)Measure voltage between ABS relay connector and chassis ground. <i>Connector & terminal</i> <i>LHD model</i> <i>(B225) No. 5 (+) — Chassis ground (-):</i> <i>RHD model</i> <i>(B225) No. 3 (+) — Chassis ground (-):</i>	Is the voltage more than 10 V?	Go to step 4.	Repair open circuit in harness between battery and Relay holder connector.
4 CHECK RELAY HOLDER.	Is the fuse blown out?	Replace fuse.	Go to step 5.
5 CHECK INPUT VOLTAGE OF ABS RELAY. 1)Install fuse. 2)Remove ABS relay. 3)Turn ignition switch to ON. 4)Measure voltage between ABS relay connector and chassis ground. <i>Connector & terminal</i> <i>(B264) No. 2 (+) — Chassis ground (-):</i>	Is the voltage more than 10 V?	Go to step 6.	Repair open circuit in harness between battery and Relay holder connector.
6 CHECK INPUT VOLTAGE OF ABS RELAY. Measure voltage between ABS relay connector and chassis ground. <i>Connector & terminal</i> <i>(B264) No. 1 (+) — Chassis ground (-):</i>	Is the voltage more than 10 V?	Go to step 7.	Repair harness connector between battery, ignition switch and ABS relay.
7 CHECK GROUND CIRCUIT OF ABS RELAY. 1)Turn ignition switch to OFF. 2)Measure resistance between ABS relay connector and chassis ground. <i>Connector & terminal</i> <i>(B264) No. 3 (+) — Chassis ground:</i>	Is the resistance less than 5 Ω ?	Go to step 8.	Repair open circuit between ABS relay and chassis ground.
8 CHECK ABS RELAY. 1)Connect battery to ABS relay terminal No. 1 and 3. 2)Measure resistance between ABS relay terminals.	Is the resistance less than 10 Ω ?	Go to step 9.	Replace ABS relay.
9 CHECK INPUT VOLTAGE OF ABSCM&H/U. 1)Disconnect connector from ABSCM&H/U. 2)Run the engine at idle. 3)Measure voltage between ABSCM&H/U connector and chassis ground. <i>Connector & terminal</i> <i>(F49) No. 1 (+) — Chassis ground (-):</i>	Is the voltage between 10 and 17 V?	Go to step 10.	Repair harness connector between battery, ignition switch and ABSCM&H/U.
10 CHECK GROUND CIRCUIT OF ABSCM&H/U. 1)Turn ignition switch to OFF. 2)Measure resistance between ABSCM&H/U connector and chassis ground. <i>Connector & terminal</i> <i>(F49) No. 23 — Chassis ground:</i>	Is the resistance less than 0.5 Ω ?	Go to step 11.	Repair ABSCM&H/U ground harness.

DIAGNOSTICS CHART WITH SUBARU SELECT MONITOR

ABS (DIAGNOSTICS)

Step	Check	Yes	No
11	CHECK POOR CONTACT IN CONNECTORS.	Is there poor contact in connectors between generator, battery and ABSCM&H/U?	Repair connector. Go to step 12 .
12	CHECK ABSCM&H/U. 1)Connect all connectors. 2)Erase the memory. 3)Perform inspection mode. 4)Read out the trouble code.	Is the same trouble code as in the current diagnosis still being output?	Replace ABSCM&H/U. <Ref. to ABS-7, ABS Control Module and Hydraulic Control Unit (ABSCM&H/U).> Go to step 13 .
13	CHECK ANY OTHER TROUBLE CODES APPEARANCE.	Are other trouble codes being output?	Proceed with the diagnosis corresponding to the trouble code. A temporary poor contact.

DIAGNOSTICS CHART WITH SUBARU SELECT MONITOR

ABS (DIAGNOSTICS)

DIAGNOSTICS CHART WITH SUBARU SELECT MONITOR

ABS (DIAGNOSTICS)

W: TROUBLE CODE 44 — ABS-AT CONTROL (NON CONTROLLED) —

DIAGNOSIS:

- Combination of AT control faults

TROUBLE SYMPTOM:

- ABS does not operate.

WIRING DIAGRAM:

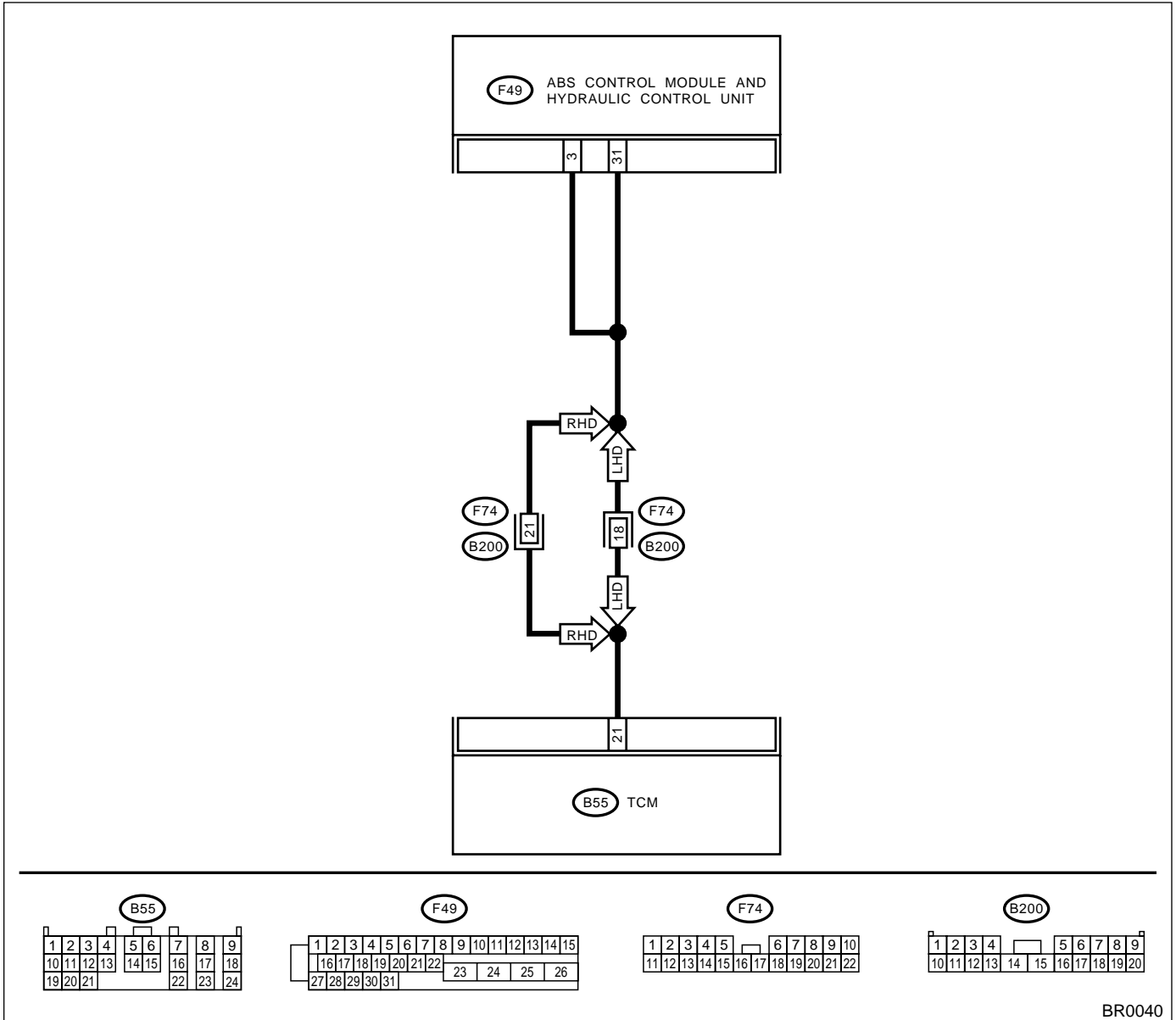

BR0040

DIAGNOSTICS CHART WITH SUBARU SELECT MONITOR

ABS (DIAGNOSTICS)

Step	Check	Yes	No
1 CHECK SPECIFICATIONS OF THE ABSCM&H/U. Check specifications of the mark to the ABSCM&H/U. <i>CA: AT (FWD)</i> <i>CB: MT (FWD)</i> <i>CC: AT (AWD)</i> <i>CD: MT (AWD)</i>	Is an ABSCM&H/U for AT model installed on a MT model?	Replace ABSCM&H/U. <Ref. to ABS-7, ABS Control Module and Hydraulic Control Unit (ABSCM&H/U).>	Go to step 2.
2 CHECK GROUND SHORT OF HARNESS. 1)Turn ignition switch to OFF. 2)Disconnect two connectors from TCM. 3)Disconnect connector from ABSCM&H/U. 4)Measure resistance between ABSCM&H/U connector and chassis ground. Connector & terminal (F49) No. 3 — Chassis ground:	Is the resistance more than 1 MΩ?	Go to step 3.	Repair harness between TCM and ABSCM&H/U.
3 CHECK TCM. 1)Connect all connectors to TCM. 2)Turn ignition switch to ON. 3)Measure voltage between TCM connector terminal and chassis ground. Connector & terminal (B55) No. 21 (+) — Chassis ground (-):	Is the voltage between 10 and 15 V?	Go to step 5.	Go to step 4.
4 CHECK AT.	Is the AT functioning normally?	Replace TCM.	Repair AT.
5 CHECK OPEN CIRCUIT OF HARNESS. Measure voltage between ABSCM&H/U connector and chassis ground. Connector & terminal (F49) No. 3 (+) — Chassis ground (-): (F49) No. 31 (+) — Chassis ground (-):	Is the voltage more than 10 V?	Go to step 6.	Repair harness/connector between TCM and ABSCM&H/U.
6 CHECK POOR CONTACT IN CONNECTORS.	Is there poor contact in connectors between TCM and ABSCM&H/U?	Repair connector.	Go to step 7.
7 CHECK ABSCM&H/U. 1)Connect all connectors. 2)Erase the memory. 3)Perform inspection mode. 4)Read out the trouble code.	Is the same trouble code as in the current diagnosis still being output?	Replace ABSCM&H/U. <Ref. to ABS-7, ABS Control Module and Hydraulic Control Unit (ABSCM&H/U).>	Go to step 8.
8 CHECK ANY OTHER TROUBLE CODES APPEARANCE.	Are other trouble codes being output?	Proceed with the diagnosis corresponding to the trouble code.	A temporary poor contact.

DIAGNOSTICS CHART WITH SUBARU SELECT MONITOR

ABS (DIAGNOSTICS)

X: TROUBLE CODE 44 — ABS-AT CONTROL (CONTROLLED) —

DIAGNOSIS:

- Combination of AT control faults

TROUBLE SYMPTOM:

- ABS does not operate.

WIRING DIAGRAM:

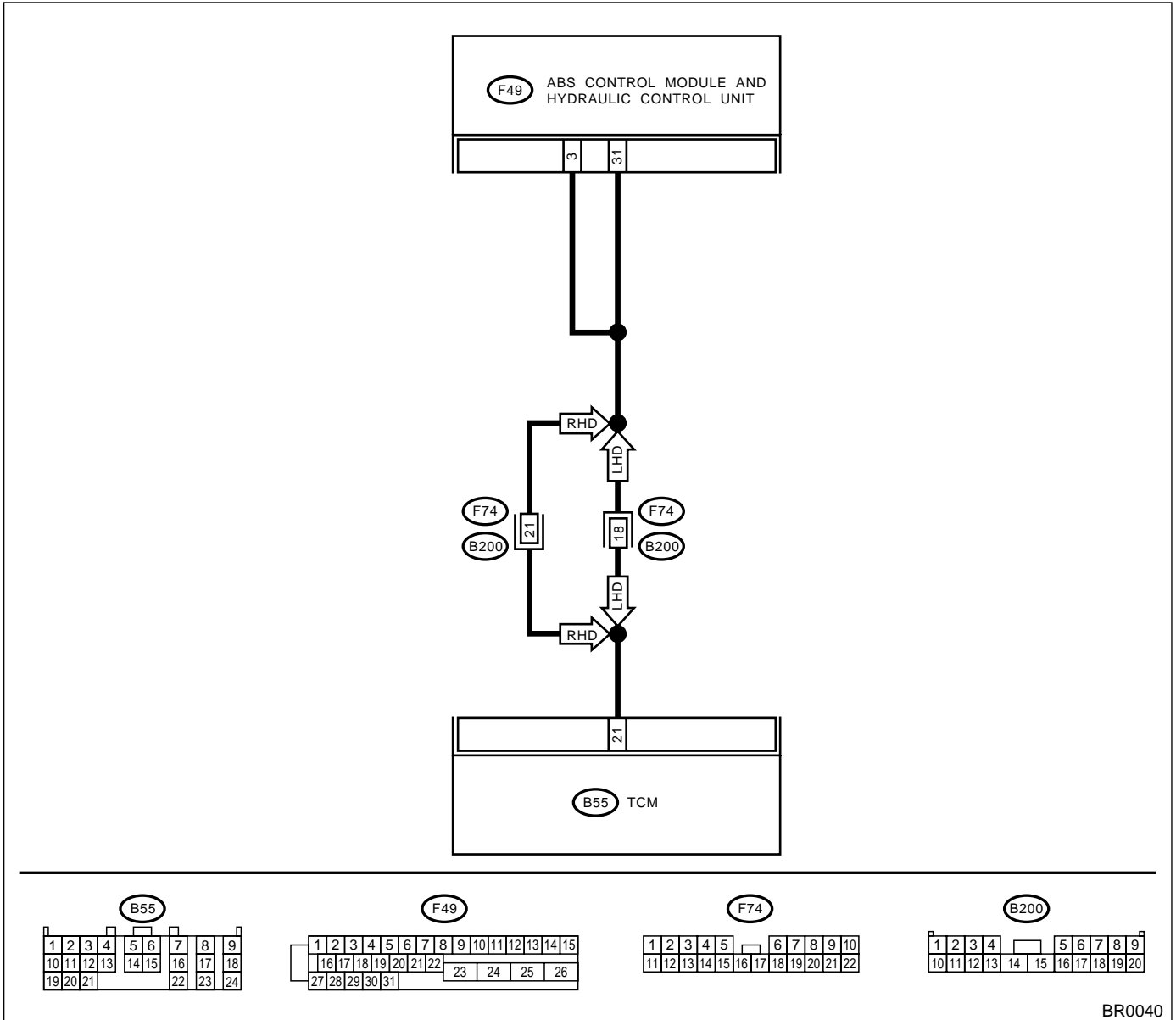

BR0040

DIAGNOSTICS CHART WITH SUBARU SELECT MONITOR

ABS (DIAGNOSTICS)

Step	Check	Yes	No
1 CHECK BATTERY SHORT OF HARNESS. 1)Turn ignition switch to OFF. 2)Disconnect two connectors from TCM. 3)Disconnect connector from ABSCM&H/U. 4)Measure voltage between ABSCM&H/U connector and chassis ground. Connector & terminal (F49) No. 3 (+) — Chassis ground (-):	Is the voltage less than 1 V?	Go to step 2.	Repair harness between TCM and ABSCM&H/U.
2 CHECK BATTERY SHORT OF HARNESS. 1)Turn ignition switch to ON. 2)Measure voltage between ABSCM&H/U connector and chassis ground. Connector & terminal (F49) No. 3 (+) — Chassis ground (-):	Is the voltage less than 1 V?	Go to step 3.	Repair harness between TCM and ABSCM&H/U.
3 CHECK OPEN CIRCUIT OF HARNESS. 1)Turn ignition switch to OFF. 2)Connect all connectors to TCM. 3)Turn ignition switch to ON. 4)Measure voltage between ABSCM&H/U connector and chassis ground. Connector & terminal (F49) No. 3 (+) — Chassis ground (-): (F49) No. 31 (+) — Chassis ground (-):	Is the voltage between 10 and 13 V?	Go to step 4.	Repair harness/connector between TCM and ABSCM&H/U.
4 CHECK POOR CONTACT IN CONNECTORS. Turn ignition switch to OFF.	Is there poor contact in connectors between TCM and ABSCM&H/U?	Repair connector.	Go to step 5.
5 CHECK ABSCM&H/U. 1)Connect all connectors. 2)Erase the memory. 3)Perform inspection mode. 4)Read out the trouble code.	Is the same trouble code as in the current diagnosis still being output?	Replace ABSCM&H/U. <Ref. to ABS-7, ABS Control Module and Hydraulic Control Unit (ABSCM&H/U).>	Go to step 6.
6 CHECK ANY OTHER TROUBLE CODES APPEARANCE.	Are other trouble codes being output?	Proceed with the diagnosis corresponding to the trouble code.	A temporary poor contact.

DIAGNOSTICS CHART WITH SUBARU SELECT MONITOR

ABS (DIAGNOSTICS)

Y: TROUBLE CODE 51
— VALVE RELAY MALFUNCTION —

DIAGNOSIS:

- Faulty valve relay

TROUBLE SYMPTOM:

- ABS does not operate.

DIAGNOSTICS CHART WITH SUBARU SELECT MONITOR

ABS (DIAGNOSTICS)

WIRING DIAGRAM:

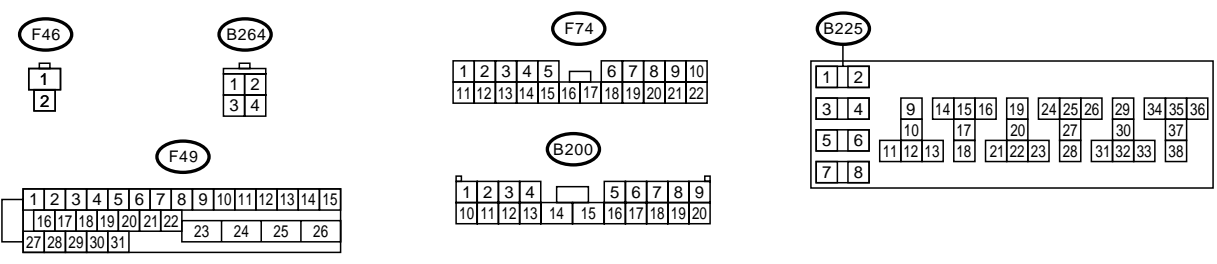
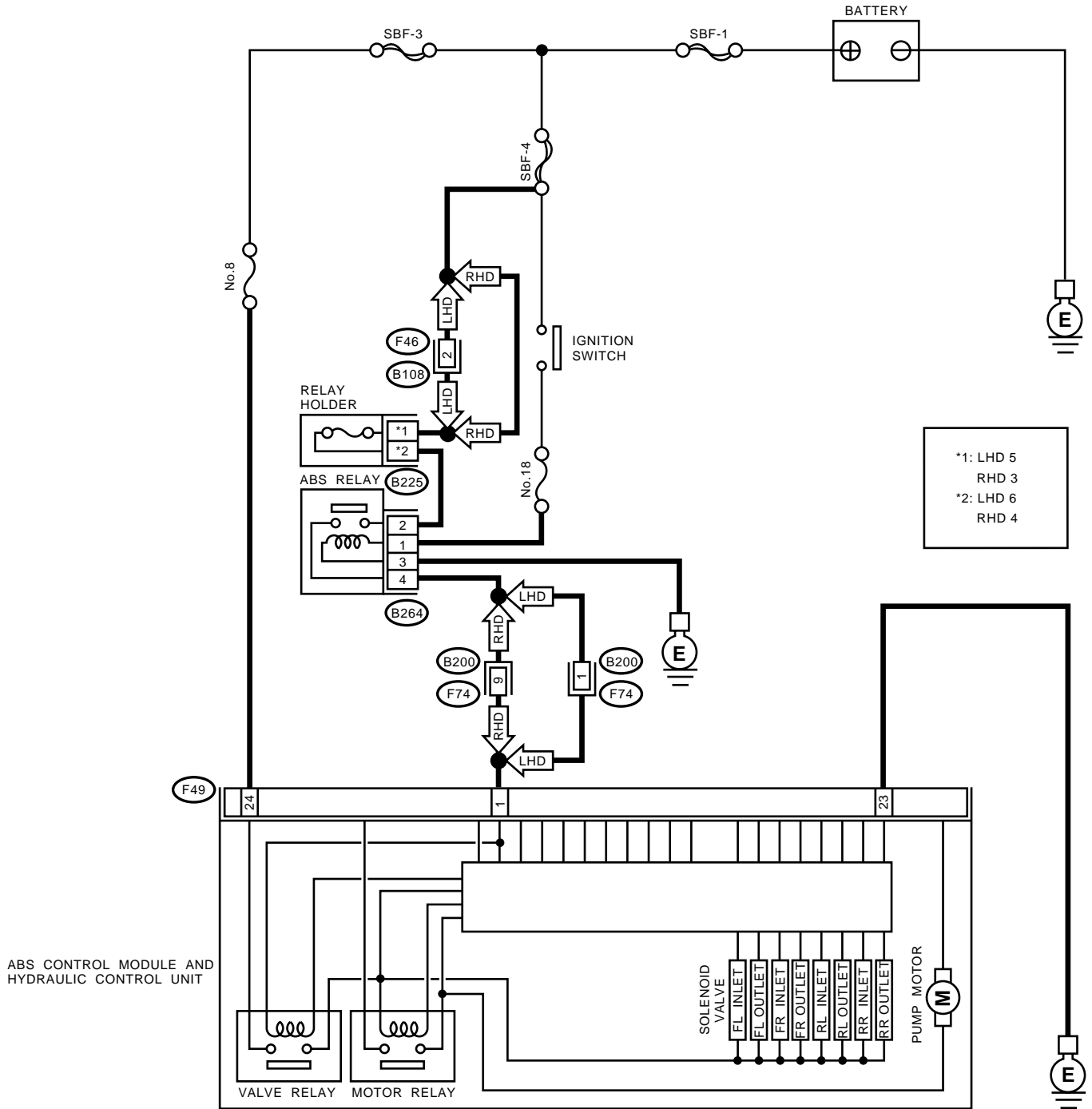

BR0041

DIAGNOSTICS CHART WITH SUBARU SELECT MONITOR

ABS (DIAGNOSTICS)

Step	Check	Yes	No
1 CHECK INPUT VOLTAGE OF RELAY HOLDER. 1) Turn ignition switch to OFF. 2) Remove fuse. 3) Measure voltage between ABS relay connector and chassis ground. Connector & terminal <i>LHD model</i> (B225) No. 5 (+) — Chassis ground (-): <i>RHD model</i> (B225) No. 3 (+) — Chassis ground (-):	Is the voltage more than 10 V?	Go to step 2.	Repair open circuit in harness between battery and Relay holder connector.
2 CHECK RELAY HOLDER.	Is the fuse blown out?	Replace fuse.	Go to step 3.
3 CHECK INPUT VOLTAGE OF ABS RELAY. 1) Install fuse. 2) Remove ABS relay. 3) Turn ignition switch to ON. 4) Measure voltage between ABS relay connector and chassis ground. Connector & terminal (B264) No. 2 (+) — Chassis ground (-):	Is the voltage more than 10 V?	Go to step 4.	Repair open circuit in harness between battery and Relay holder connector.
4 CHECK INPUT VOLTAGE OF ABS RELAY. Measure voltage between ABS relay connector and chassis ground. Connector & terminal (B264) No. 1 (+) — Chassis ground (-):	Is the voltage more than 10 V?	Go to step 5.	Repair harness connector between battery, ignition switch and ABS relay.
5 CHECK GROUND CIRCUIT OF ABS RELAY. 1) Turn ignition switch to OFF. 2) Measure resistance between ABS relay connector and chassis ground. Connector & terminal (B264) No. 3 (+) — Chassis ground:	Is the resistance less than 5 Ω ?	Go to step 6.	Repair open circuit between ABS relay and chassis ground.
6 CHECK ABS RELAY. 1) Connect battery to ABS relay terminal No. 1 and 3. 2) Measure resistance between ABS relay terminals.	Is the resistance less than 10 Ω ?	Go to step 7.	Replace ABS relay.
7 CHECK INPUT VOLTAGE OF ABSCM&H/U. 1) Turn ignition switch to OFF. 2) Disconnect connector from ABSCM&H/U. 3) Run the engine at idle. 4) Measure voltage between ABSCM&H/U connector and chassis ground. Connector & terminal (F49) No. 1 (+) — Chassis ground (-): (F49) No. 24 (+) — Chassis ground (-):	Is the voltage between 10 and 15 V?	Go to step 8.	Repair harness connector between battery and ABSCM&H/U.
8 CHECK GROUND CIRCUIT OF ABSCM&H/U. 1) Turn ignition switch to OFF. 2) Measure resistance between ABSCM&H/U connector and chassis ground. Connector & terminal (F49) No. 23 — Chassis ground:	Is the resistance less than 0.5 Ω ?	Go to step 9.	Repair ABSCM&H/U ground harness.
9 CHECK POOR CONTACT IN CONNECTORS.	Is there poor contact in connectors between generator, battery and ABSCM&H/U?	Repair connector.	Go to step 10.

DIAGNOSTICS CHART WITH SUBARU SELECT MONITOR

ABS (DIAGNOSTICS)

Step	Check	Yes	No
10 CHECK ABSCM&H/U. 1)Connect all connectors. 2)Erase the memory. 3)Perform inspection mode. 4)Read out the trouble code.	Is the same trouble code as in the current diagnosis still being output?	Replace ABSCM&H/U. <Ref. to ABS-7, ABS Control Module and Hydraulic Control Unit (ABSCM&H/U).>	Go to step 11.
11 CHECK ANY OTHER TROUBLE CODES APPEARANCE.	Are other trouble codes being output?	Proceed with the diagnosis corresponding to the trouble code.	A temporary poor contact.

Z: TROUBLE CODE 51
— VALVE RELAY ON FAILURE —

DIAGNOSIS:

- Faulty valve relay

TROUBLE SYMPTOM:

- ABS does not operate.

DIAGNOSTICS CHART WITH SUBARU SELECT MONITOR

ABS (DIAGNOSTICS)

WIRING DIAGRAM:

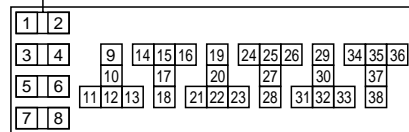
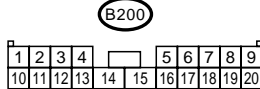
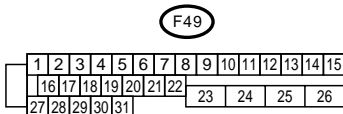
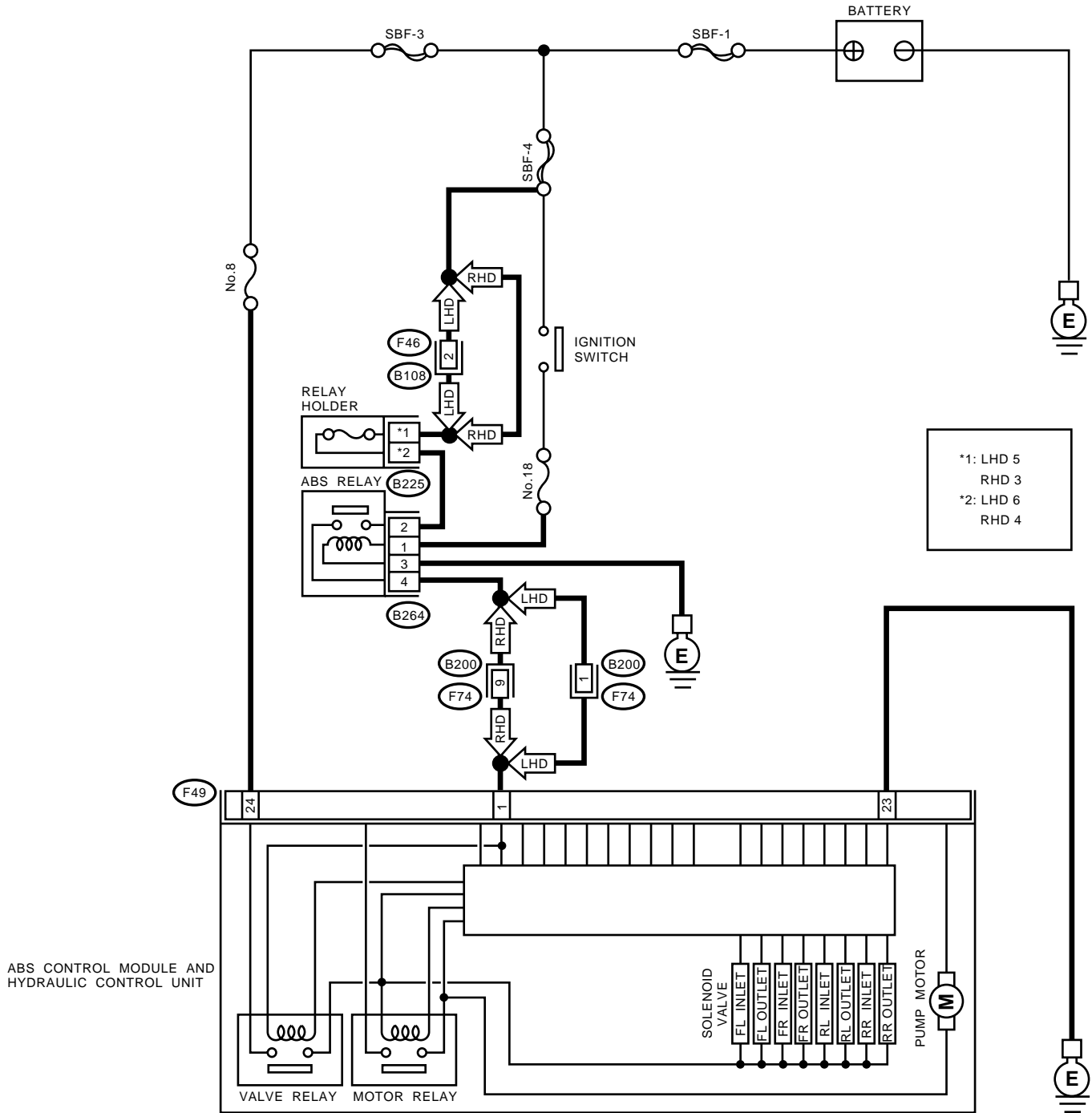

BR0041

DIAGNOSTICS CHART WITH SUBARU SELECT MONITOR

ABS (DIAGNOSTICS)

Step	Check	Yes	No
1 CHECK VALVE RELAY IN ABSCM&H/U. Measure resistance between ABSCM&H/U terminals. <i>Terminals</i> No. 23 (+) — No. 24 (-):	Is the resistance more than 1 MΩ?	Go to step 2.	Replace ABSCM&H/U. <Ref. to ABS-7, ABS Control Module and Hydraulic Control Unit (ABSCM&H/U).>
2 CHECK POOR CONTACT IN CONNECTORS.	Is there poor contact in connectors between generator, battery and ABSCM&H/U?	Repair connector.	Go to step 3.
3 CHECK ABSCM&H/U. 1)Connect all connectors. 2)Erase the memory. 3)Perform inspection mode. 4)Read out the trouble code.	Is the same trouble code as in the current diagnosis still being output?	Replace ABSCM&H/U. <Ref. to ABS-7, ABS Control Module and Hydraulic Control Unit (ABSCM&H/U).>	Go to step 4.
4 CHECK ANY OTHER TROUBLE CODES APPEARANCE.	Are other trouble codes being output?	Proceed with the diagnosis corresponding to the trouble code.	A temporary poor contact.

DIAGNOSTICS CHART WITH SUBARU SELECT MONITOR

ABS (DIAGNOSTICS)

AA:TROUBLE CODE 52

— OPEN CIRCUIT IN MOTOR RELAY CIRCUIT —

DIAGNOSIS:

- Faulty motor
- Faulty motor relay
- Faulty harness connector

TROUBLE SYMPTOM:

- ABS does not operate.

DIAGNOSTICS CHART WITH SUBARU SELECT MONITOR

ABS (DIAGNOSTICS)

WIRING DIAGRAM:

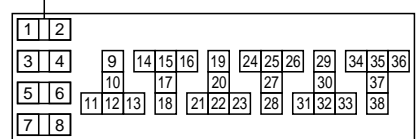
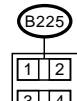
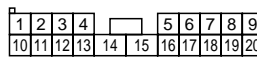
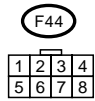
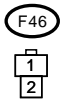
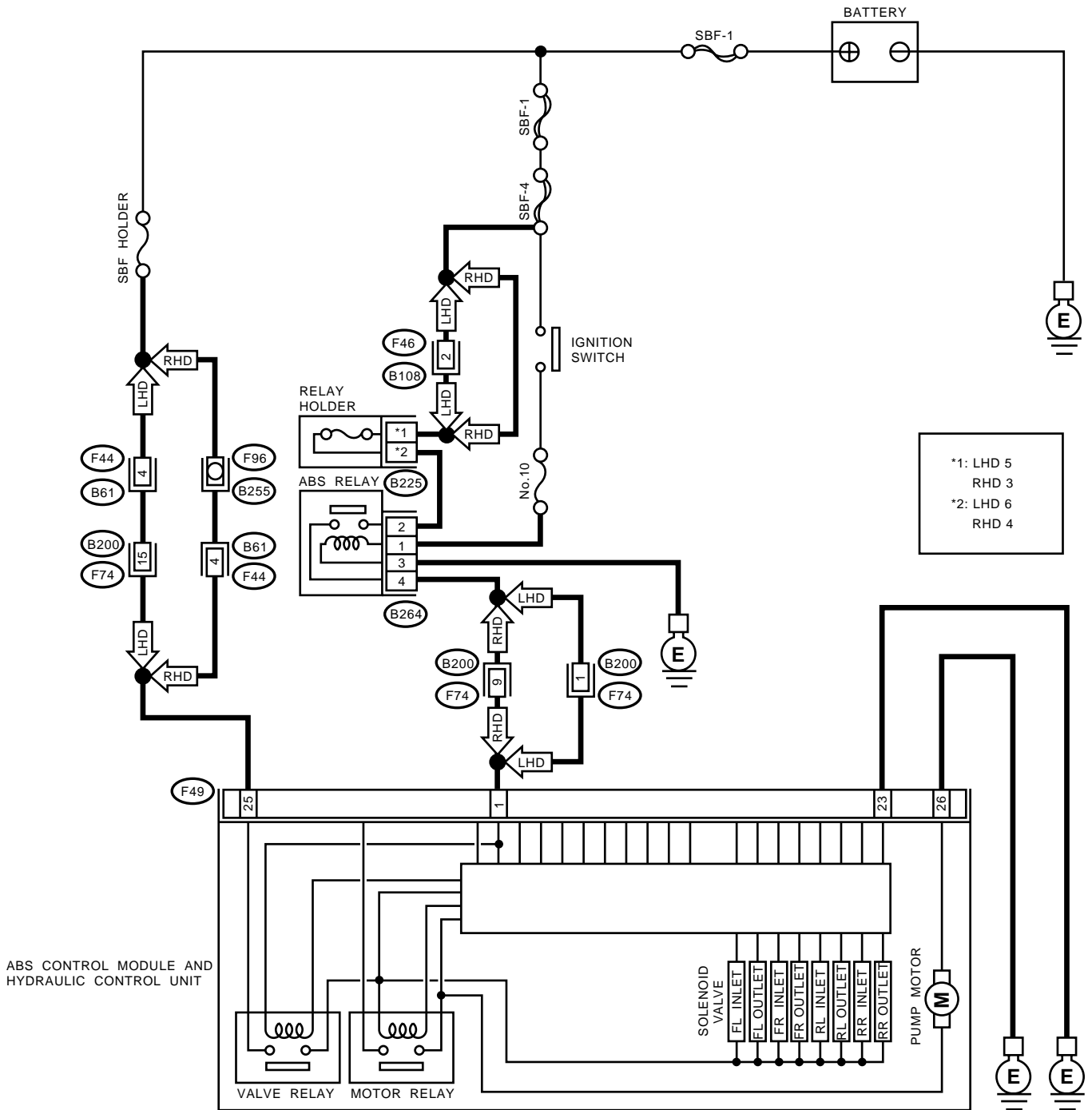

BR0042

DIAGNOSTICS CHART WITH SUBARU SELECT MONITOR

ABS (DIAGNOSTICS)

Step	Check	Yes	No
1 CHECK INPUT VOLTAGE OF ABSCM&H/U. 1) Turn ignition switch to OFF. 2) Disconnect connector from ABSCM&H/U. 3) Turn ignition switch to ON. 4) Measure voltage between ABSCM&H/U connector and chassis ground. Connector & terminal (F49) No. 25 (+) — Chassis ground (-):	Is the voltage between 10 and 13 V?	Go to step 2.	Repair harness/connector between battery and ABSCM&H/U and check fuse SBF6.
2 CHECK GROUND CIRCUIT OF MOTOR. 1) Turn ignition switch to OFF. 2) Measure resistance between ABSCM&H/U connector and chassis ground. Connector & terminal (F49) No. 26 — Chassis ground:	Is the resistance less than 0.5 Ω ?	Go to step 3.	Repair ABSCM&H/U ground harness.
3 CHECK MOTOR OPERATION. Operate the sequence control. <Ref. to ABS-11, ABS Sequence Control.> NOTE: Use the diagnosis connector to operate the sequence control.	Can motor revolution noise (buzz) be heard when carrying out the check sequence?	Go to step 4.	Replace ABSCM&H/U. <Ref. to ABS-7, ABS Control Module and Hydraulic Control Unit (ABSCM&H/U).>
4 CHECK POOR CONTACT IN CONNECTORS. Turn ignition switch to OFF.	Is there poor contact in connector between hydraulic unit, relay box and ABSCM&H/U?	Repair connector.	Go to step 5.
5 CHECK ABSCM&H/U. 1) Connect all connectors. 2) Erase the memory. 3) Perform inspection mode. 4) Read out the trouble code.	Is the same trouble code as in the current diagnosis still being output?	Replace ABSCM&H/U. <Ref. to ABS-7, ABS Control Module and Hydraulic Control Unit (ABSCM&H/U).>	Go to step 6.
6 CHECK ANY OTHER TROUBLE CODES APPEARANCE.	Are other trouble codes being output?	Proceed with the diagnosis corresponding to the trouble code.	A temporary poor contact.

DIAGNOSTICS CHART WITH SUBARU SELECT MONITOR

ABS (DIAGNOSTICS)

AB:TROUBLE CODE 52

— MOTOR RELAY ON FAILURE —

DIAGNOSIS:

- Faulty motor
- Faulty motor relay
- Faulty harness connector

TROUBLE SYMPTOM:

- ABS does not operate.

DIAGNOSTICS CHART WITH SUBARU SELECT MONITOR

ABS (DIAGNOSTICS)

WIRING DIAGRAM:

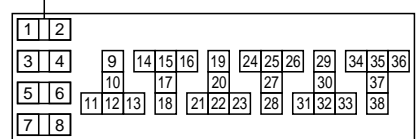
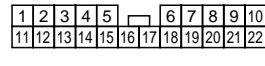
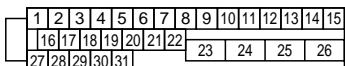
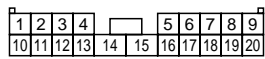
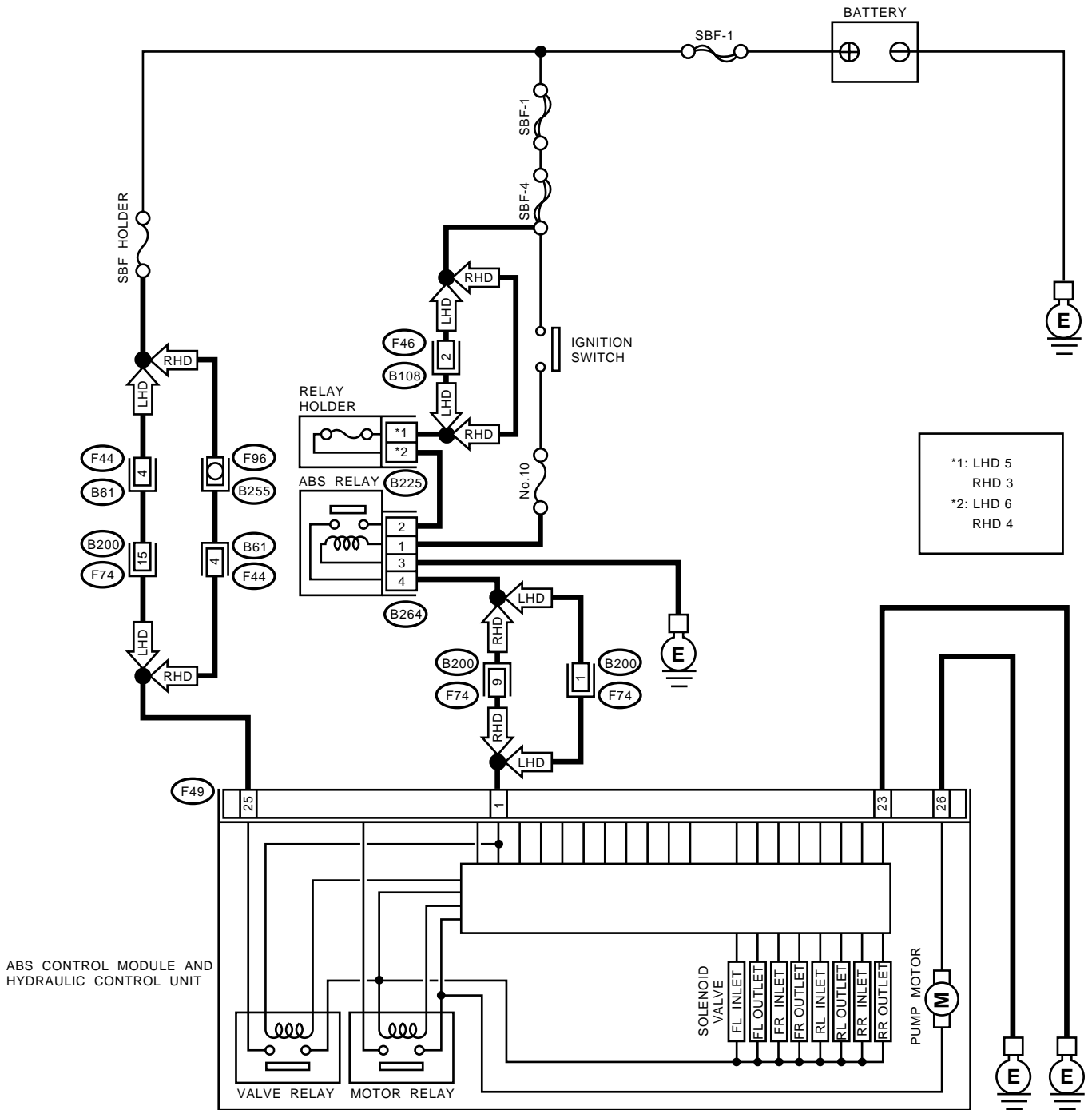

BR0042

DIAGNOSTICS CHART WITH SUBARU SELECT MONITOR

ABS (DIAGNOSTICS)

Step	Check	Yes	No
1 CHECK MOTOR RELAY IN ABSCM&H/U. Measure resistance between ABSCM&H/U terminals. <i>Terminals</i> No. 25 — No. 26:	Is the resistance more than 1 MΩ?	Go to step 2.	Replace ABSCM&H/U. <Ref. to ABS-7, ABS Control Module and Hydraulic Control Unit (ABSCM&H/U).>
2 CHECK MOTOR OPERATION. Operate the sequence control. <Ref. to ABS-11, ABS Sequence Control.> NOTE: Use the diagnosis connector to operate the sequence control.	Can motor revolution noise (buzz) be heard when carrying out the sequence control?	Go to step 3.	Replace ABSCM&H/U. <Ref. to ABS-7, ABS Control Module and Hydraulic Control Unit (ABSCM&H/U).>
3 CHECK POOR CONTACT IN CONNECTORS. Turn ignition switch to OFF.	Is there poor contact in connector between hydraulic unit, relay box and ABSCM&H/U?	Repair connector.	Go to step 4.
4 CHECK ABSCM&H/U. 1)Connect all connectors. 2)Erase the memory. 3)Perform inspection mode. 4)Read out the trouble code.	Is the same trouble code as in the current diagnosis still being output?	Replace ABSCM&H/U. <Ref. to ABS-7, ABS Control Module and Hydraulic Control Unit (ABSCM&H/U).>	Go to step 5.
5 CHECK ANY OTHER TROUBLE CODES APPEARANCE.	Are other trouble codes being output?	Proceed with the diagnosis corresponding to the trouble code.	A temporary poor contact.

DIAGNOSTICS CHART WITH SUBARU SELECT MONITOR

ABS (DIAGNOSTICS)

AC:TROUBLE CODE 52
— MOTOR MALFUNCTION —

DIAGNOSIS:

- Faulty motor
- Faulty motor relay
- Faulty harness connector

TROUBLE SYMPTOM:

- ABS does not operate.

DIAGNOSTICS CHART WITH SUBARU SELECT MONITOR

ABS (DIAGNOSTICS)

WIRING DIAGRAM:

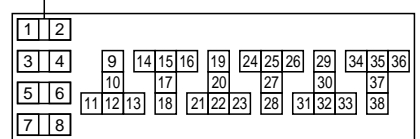
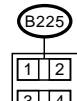
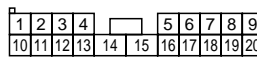
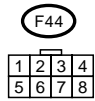
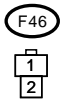
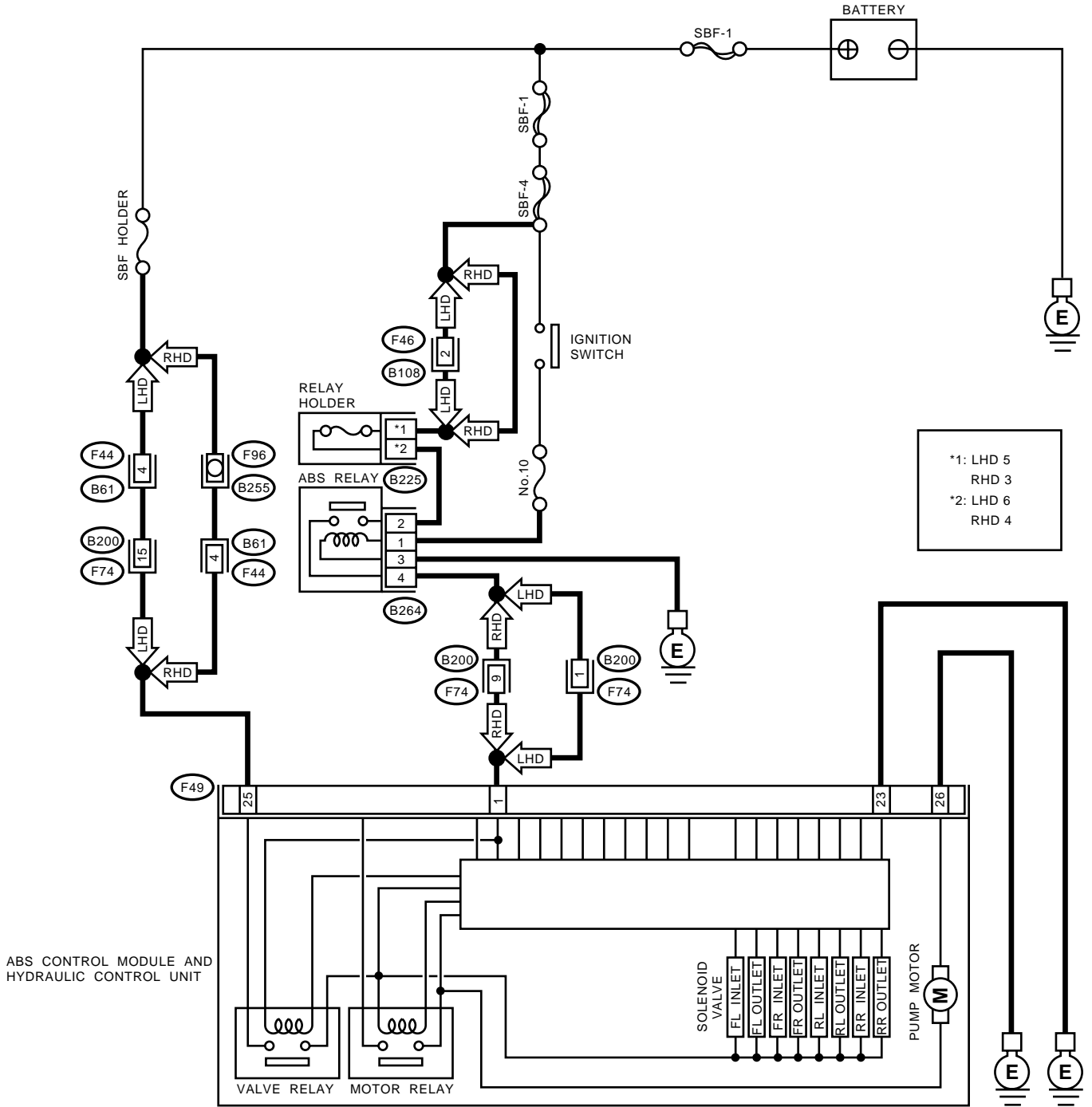

BR0042

DIAGNOSTICS CHART WITH SUBARU SELECT MONITOR

ABS (DIAGNOSTICS)

Step	Check	Yes	No
1 CHECK INPUT VOLTAGE OF ABSCM&H/U. 1) Turn ignition switch to OFF. 2) Disconnect connector from ABSCM&H/U. 3) Turn ignition switch to ON. 4) Measure voltage between ABSCM&H/U connector and chassis ground. Connector & terminal (F49) No. 25 (+) — Chassis ground (-):	Is the voltage between 10 and 13 V?	Go to step 2.	Repair harness/connector between battery and ABSCM&H/U and check fuse SBF6.
2 CHECK GROUND CIRCUIT OF MOTOR. 1) Turn ignition switch to OFF. 2) Measure resistance between ABSCM&H/U connector and chassis ground. Connector & terminal (F49) No. 26 — Chassis ground:	Is the resistance less than 0.5 Ω?	Go to step 3.	Repair ABSCM&H/U ground harness.
3 CHECK INPUT VOLTAGE OF ABSCM&H/U. 1) Run the engine at idle. 2) Measure voltage between ABSCM&H/U connector and chassis ground. Connector & terminal (F49) No. 1 (+) — Chassis ground (-):	Is the voltage between 10 and 15 V?	Go to step 4.	Repair harness connector between battery, ignition switch and ABSCM&H/U.
4 CHECK GROUND CIRCUIT OF ABSCM&H/U. 1) Turn ignition switch to OFF. 2) Measure resistance between ABSCM&H/U connector and chassis ground. Connector & terminal (F49) No. 23 — Chassis ground:	Is the resistance less than 0.5 Ω?	Go to step 5.	Repair ABSCM&H/U ground harness.
5 CHECK MOTOR OPERATION. Operate the sequence control. <Ref. to ABS-11, ABS Sequence Control.> NOTE: Use the diagnosis connector to operate the sequence control.	Can motor revolution noise (buzz) be heard when carrying out the sequence control?	Go to step 6.	Replace ABSCM&H/U. <Ref. to ABS-7, ABS Control Module and Hydraulic Control Unit (ABSCM&H/U).>
6 CHECK POOR CONTACT IN CONNECTORS. Turn ignition switch to OFF.	Is there poor contact in connector between generator, battery and ABSCM&H/U?	Repair connector.	Go to step 7.
7 CHECK ABSCM&H/U. 1) Connect all connectors. 2) Erase the memory. 3) Perform inspection mode. 4) Read out the trouble code.	Is the same trouble code as in the current diagnosis still being output?	Replace ABSCM&H/U. <Ref. to ABS-7, ABS Control Module and Hydraulic Control Unit (ABSCM&H/U).>	Go to step 8.
8 CHECK ANY OTHER TROUBLE CODES APPEARANCE.	Are other trouble codes being output?	Proceed with the diagnosis corresponding to the trouble code.	A temporary poor contact.

DIAGNOSTICS CHART WITH SUBARU SELECT MONITOR

ABS (DIAGNOSTICS)

AD:TROUBLE CODE 54

— STOP LIGHT SWITCH SIGNAL CIRCUIT MALFUNCTION —

DIAGNOSIS:

- Faulty stop light switch

TROUBLE SYMPTOM:

- ABS does not operate.

WIRING DIAGRAM:

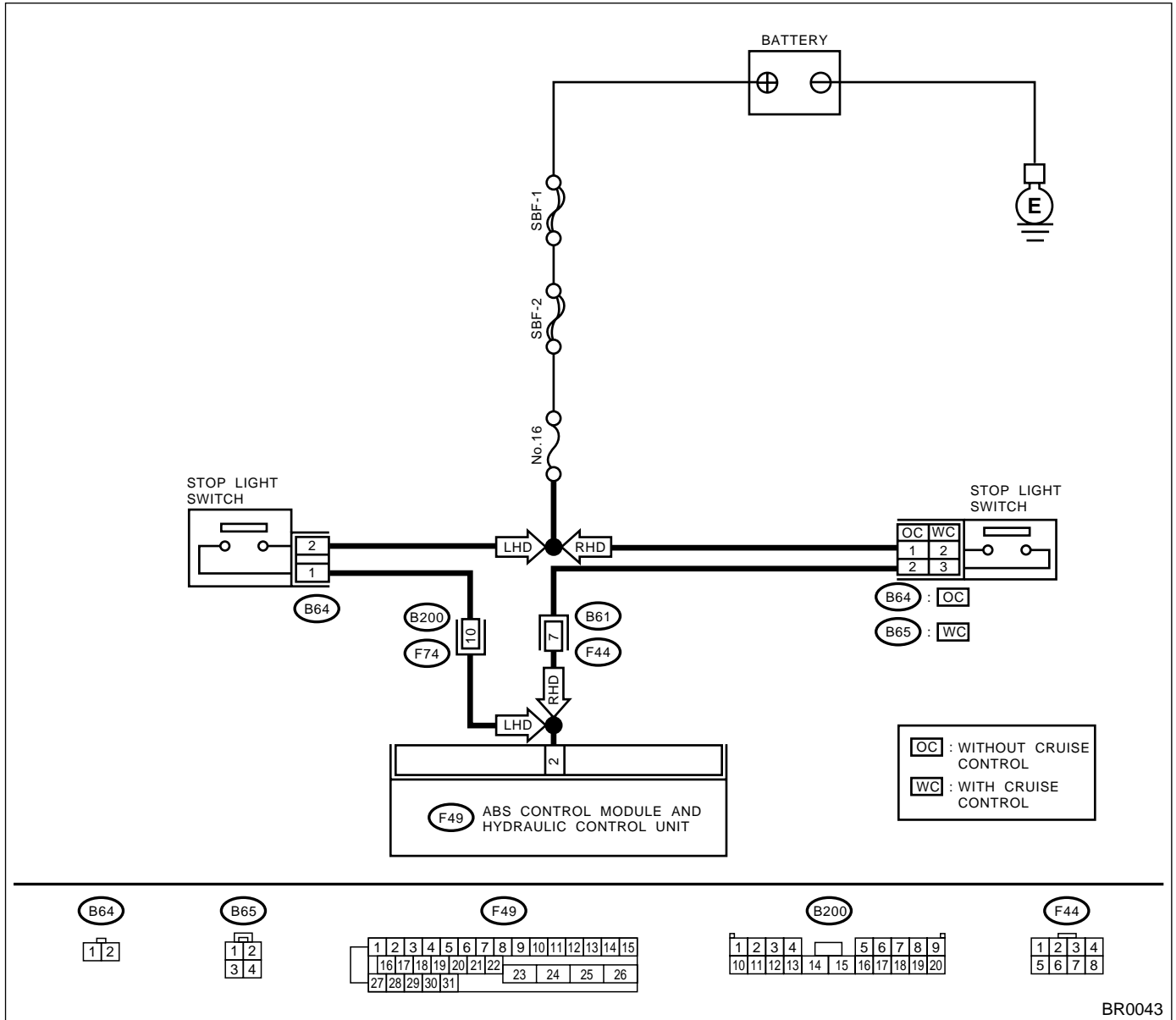

BR0043

DIAGNOSTICS CHART WITH SUBARU SELECT MONITOR

ABS (DIAGNOSTICS)

Step	Check	Yes	No
1 CHECK OUTPUT OF STOP LIGHT SWITCH USING SELECT MONITOR. 1) Select "Current data display & Save" on the select monitor. 2) Release the brake pedal. 3) Read the stop light switch output in the select monitor data display.	Is the reading indicated on monitor display less than 1.5 V?	Go to step 2.	Go to step 3.
2 CHECK OUTPUT OF STOP LIGHT SWITCH USING SELECT MONITOR. 1) Depress the brake pedal. 2) Read the stop light switch output in the select monitor data display.	Is the reading indicated on monitor display between 10 and 15 V?	Go to step 5.	Go to step 3.
3 CHECK IF STOP LIGHTS COME ON. Depress the brake pedal.	Do stop lights turn on?	Go to step 4.	Repair stop lights circuit.
4 CHECK OPEN CIRCUIT IN HARNESS. 1) Turn ignition switch to OFF. 2) Disconnect connector from ABSCM&H/U. 3) Depress brake pedal. 4) Measure voltage between ABSCM&H/U connector and chassis ground. Connector & terminal (F49) No. 2 — Chassis ground:	Is the voltage between 10 and 15 V?	Go to step 5.	Repair harness between stop light switch and ABSCM&H/U connector.
5 CHECK POOR CONTACT IN CONNECTORS.	Is there poor contact in connector between stop light switch and ABSCM&H/U?	Repair connector.	Go to step 6.
6 CHECK ABSCM&H/U. 1) Connect all connectors. 2) Erase the memory. 3) Perform inspection mode. 4) Read out the trouble code.	Is the same trouble code as in the current diagnosis still being output?	Replace ABSCM&H/U. <Ref. to ABS-7, ABS Control Module and Hydraulic Control Unit (ABSCM&H/U).>	Go to step 7.
7 CHECK ANY OTHER TROUBLE CODES APPEARANCE.	Are other trouble codes being output?	Proceed with the diagnosis corresponding to the trouble code.	A temporary poor contact.

DIAGNOSTICS CHART WITH SUBARU SELECT MONITOR

ABS (DIAGNOSTICS)

AE:TROUBLE CODE 56

— OPEN OR SHORT CIRCUIT IN G SENSOR CIRCUIT —

DIAGNOSIS:

- Faulty G sensor output voltage

TROUBLE SYMPTOM:

- ABS does not operate.

WIRING DIAGRAM: LHD MODEL

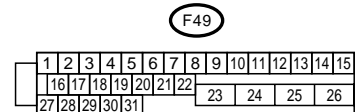
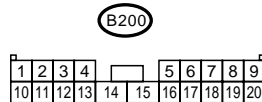
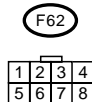
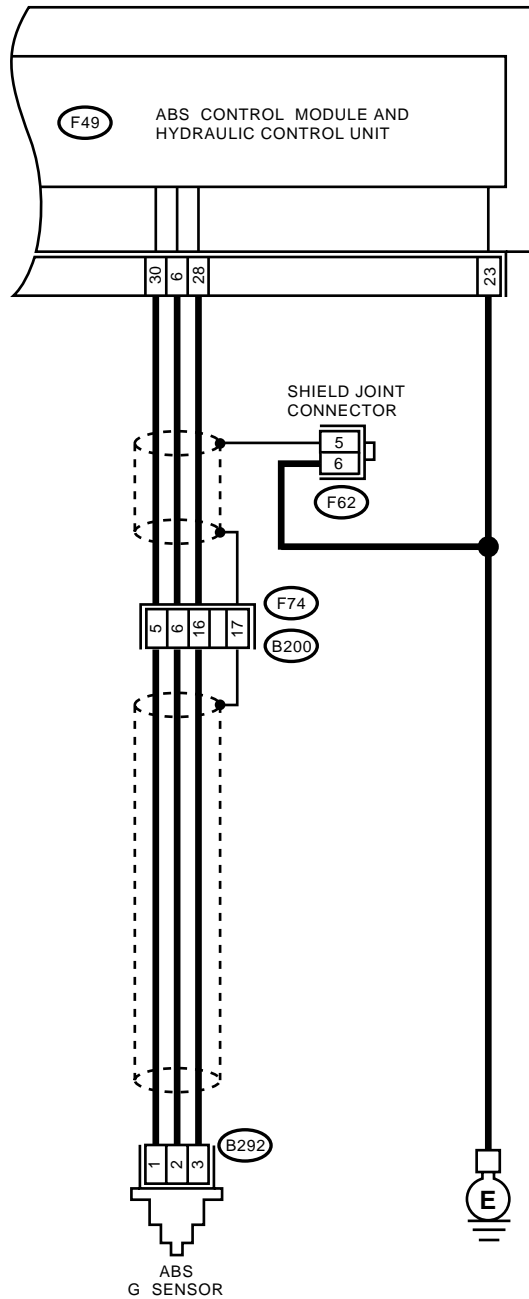

BR0044

DIAGNOSTICS CHART WITH SUBARU SELECT MONITOR

ABS (DIAGNOSTICS)

WIRING DIAGRAM: RHD MODEL

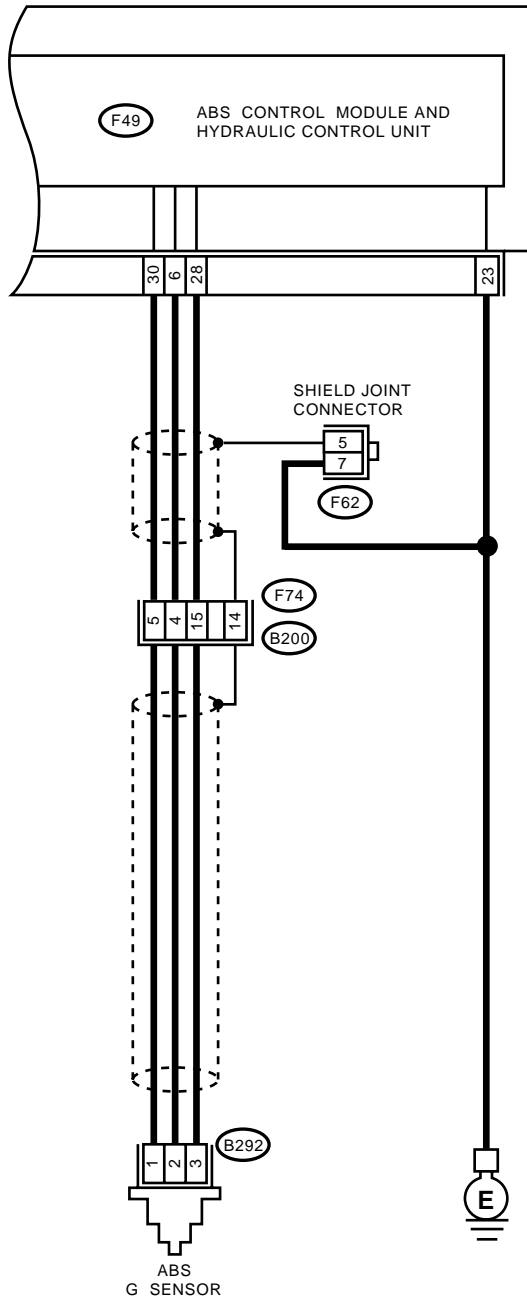

(B292)



(F62)



(F74)

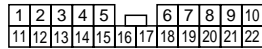

(F49)

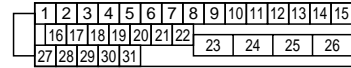

BR0045

DIAGNOSTICS CHART WITH SUBARU SELECT MONITOR

ABS (DIAGNOSTICS)

Step	Check	Yes	No	
1	CHECK OUTPUT OF G SENSOR USING SELECT MONITOR. 1) Select "Current data display & Save" on the select monitor. 2) Read the G sensor output in select monitor data display.	Is the G sensor output on the monitor display between 2.1 and 2.5 V when the G sensor is in horizontal position?	Go to step 2.	Go to step 5.
2	CHECK POOR CONTACT IN CONNECTORS.	Is there poor contact in connector between ABSCM&H/U and G sensor?	Repair connector.	Go to step 3.
3	CHECK ABSCM&H/U. 1) Connect all connectors. 2) Erase the memory. 3) Perform inspection mode. 4) Read out the trouble code.	Is the same trouble code as in the current diagnosis still being output?	Replace ABSCM&H/U. <Ref. to ABS-7, ABS Control Module and Hydraulic Control Unit (ABSCM&H/U).>	Go to step 4.
4	CHECK ANY OTHER TROUBLE CODES APPEARANCE.	Are other trouble codes being output?	Proceed with the diagnosis corresponding to the trouble code.	A temporary poor contact.
5	CHECK INPUT VOLTAGE OF G SENSOR. 1) Turn ignition switch to OFF. 2) Remove console box. 3) Disconnect G sensor from body. (Do not disconnect connector.) 4) Turn ignition switch to ON. 5) Measure voltage between G sensor connector terminals. Connector & terminal (B292) No. 1 (+) — No. 3 (-):	Is the voltage between 4.75 and 5.25 V?	Go to step 6.	Repair harness/connector between G sensor and ABSCM&H/U.
6	CHECK OPEN CIRCUIT IN G SENSOR OUTPUT HARNESS AND GROUND HARNESS. 1) Turn ignition switch to OFF. 2) Disconnect connector from ABSCM&H/U. 3) Measure resistance between ABSCM&H/U connector terminals. Connector & terminal (F49) No. 6 — No. 28:	Is the resistance between 4.3 and 4.9 kΩ?	Go to step 7.	Repair harness/connector between G sensor and ABSCM&H/U.
7	CHECK GROUND SHORT IN G SENSOR OUTPUT HARNESS. 1) Disconnect connector from G sensor. 2) Measure resistance between ABSCM&H/U connector and chassis ground. Connector & terminal (F49) No. 6 — Chassis ground:	Is the resistance more than 1 MΩ?	Go to step 8.	Repair harness between G sensor and ABSCM&H/U.
8	CHECK G SENSOR. 1) Connect connector to G sensor. 2) Connect connector to ABSCM&H/U. 3) Turn ignition switch to ON. 4) Measure voltage between G sensor connector terminals. Connector & terminal (B292) No. 2 (+) — No. 3 (-):	Is the voltage between 2.1 and 2.5 V when G sensor is horizontal?	Go to step 9.	Replace G sensor. <Ref. to ABS-22, G Sensor.>
9	CHECK G SENSOR. Measure voltage between G sensor connector terminals. Connector & terminal (B292) No. 2 (+) — No. 3 (-):	Is the voltage between 3.7 and 4.1 V when G sensor is inclined forwards to 90°?	Go to step 10.	Replace G sensor. <Ref. to ABS-22, G Sensor.>

DIAGNOSTICS CHART WITH SUBARU SELECT MONITOR

ABS (DIAGNOSTICS)

Step	Check	Yes	No
10 CHECK G SENSOR. Measure voltage between G sensor connector terminals. <i>Connector & terminal</i> <i>(B292) No. 2 (+) — No. 3 (-):</i>	Is the voltage between 0.5 and 0.9 V when G sensor is inclined backwards to 90°?	Go to step 11.	Replace G sensor. <Ref. to ABS-22, G Sensor.>
11 CHECK POOR CONTACT IN CONNECTORS. Turn ignition switch to OFF.	Is there poor contact in connector between ABSCM&H/U and G sensor?	Repair connector.	Go to step 12.
12 CHECK ABSCM&H/U. 1)Connect all connectors. 2)Erase the memory. 3)Perform inspection mode. 4)Read out the trouble code.	Is the same trouble code as in the current diagnosis still being output?	Replace ABSCM&H/U. <Ref. to ABS-7, ABS Control Module and Hydraulic Control Unit (ABSCM&H/U).>	Go to step 13.
13 CHECK ANY OTHER TROUBLE CODES APPEARANCE.	Are other trouble codes being output?	Proceed with the diagnosis corresponding to the trouble code.	A temporary poor contact.

DIAGNOSTICS CHART WITH SUBARU SELECT MONITOR

ABS (DIAGNOSTICS)

AF:TROUBLE CODE 56 — BATTERY SHORT IN G SENSOR CIRCUIT —

DIAGNOSIS:

- Faulty G sensor output voltage

TROUBLE SYMPTOM:

- ABS does not operate.

WIRING DIAGRAM: LHD MODEL

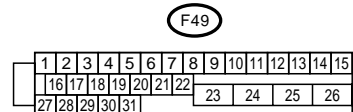
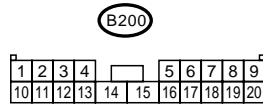
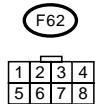
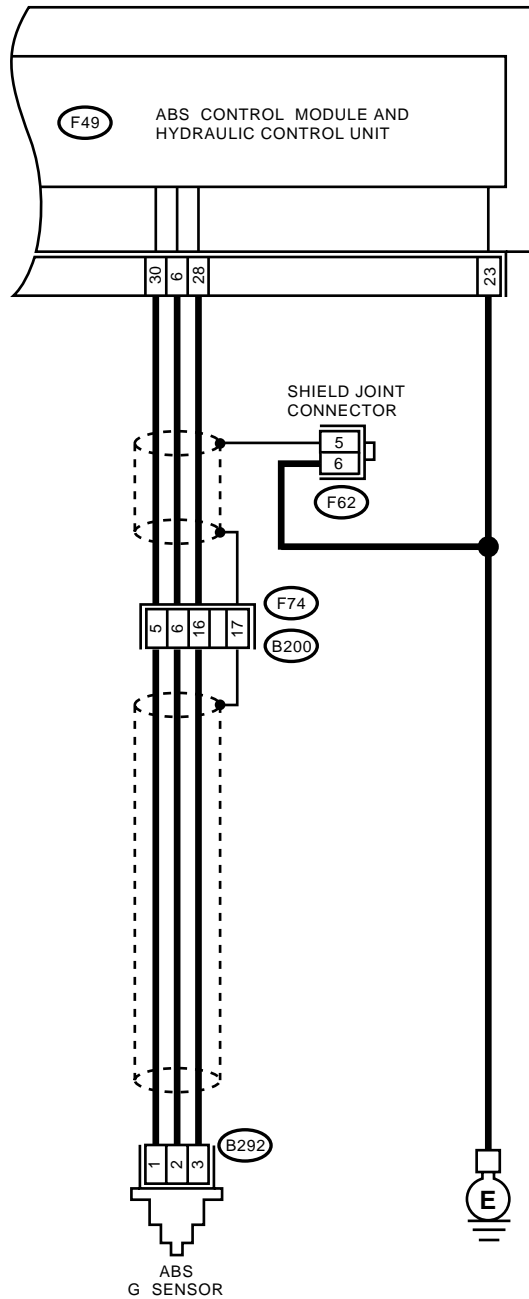

BR0044

DIAGNOSTICS CHART WITH SUBARU SELECT MONITOR

ABS (DIAGNOSTICS)

WIRING DIAGRAM: RHD MODEL

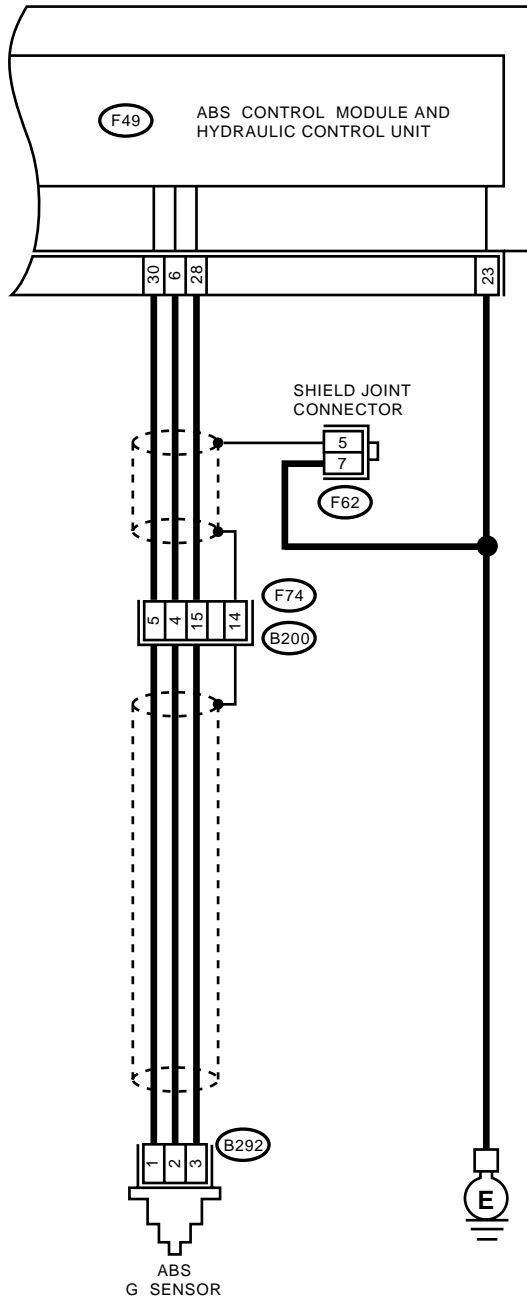

(B292)



(F62)



(F74)

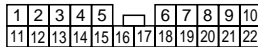

(F49)

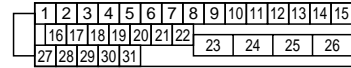

BR0045

DIAGNOSTICS CHART WITH SUBARU SELECT MONITOR

ABS (DIAGNOSTICS)

Step	Check	Yes	No
1 CHECK OUTPUT OF G SENSOR USING SELECT MONITOR. 1)Select "Current data display & Save" on the select monitor. 2)Read the G sensor output in select monitor data display.	Is the G sensor output on the monitor display between 2.1 and 2.5 V when the G sensor is in horizontal position?	Go to step 2.	Go to step 5.
2 CHECK POOR CONTACT IN CONNECTORS.	Is there poor contact in connector between ABSCM&H/U and G sensor?	Repair connector.	Go to step 3.
3 CHECK ABSCM&H/U. 1)Connect all connectors. 2)Erase the memory. 3)Perform inspection mode. 4)Read out the trouble code.	Is the same trouble code as in the current diagnosis still being output?	Replace ABSCM&H/U. <Ref. to ABS-7, ABS Control Module and Hydraulic Control Unit (ABSCM&H/U).>	Go to step 4.
4 CHECK ANY OTHER TROUBLE CODES APPEARANCE.	Are other trouble codes being output?	Proceed with the diagnosis corresponding to the trouble code.	A temporary poor contact.
5 CHECK FREEZE FRAME DATA. 1)Select "Freeze frame data" on the select monitor. 2)Read front right wheel speed on the select monitor display.	Is the front right wheel speed on monitor display 0 km?	Go to step 6.	Go to step 16.
6 CHECK FREEZE FRAME DATA. Read front left wheel speed on the select monitor display.	Is the front left wheel speed on monitor display 0 km?	Go to step 7.	Go to step 16.
7 CHECK FREEZE FRAME DATA. Read rear right wheel speed on the select monitor display.	Is the rear right wheel speed on monitor display 0 km?	Go to step 8.	Go to step 16.
8 CHECK FREEZE FRAME DATA. Read rear left wheel speed on the select monitor display.	Is the rear left wheel speed on monitor display 0 km?	Go to step 9.	Go to step 16.
9 CHECK FREEZE FRAME DATA. Read G sensor output on the select monitor display.	Is the G sensor output on monitor display more than 3.65 V?	Go to step 10.	Go to step 16.
10 CHECK OPEN CIRCUIT IN G SENSOR OUTPUT HARNESS AND GROUND HARNESS. 1)Turn ignition switch to OFF. 2)Disconnect connector from ABSCM&H/U. 3)Measure resistance between ABSCM&H/U connector terminals. <i>Connector & terminal (F49) No. 6 — No. 28:</i>	Is the resistance between 4.3 and 4.9 kΩ?	Go to step 11.	Repair harness/connector between G sensor and ABSCM&H/U.
11 CHECK BATTERY SHORT OF HARNESS. 1)Turn ignition switch to OFF. 2)Remove console box. 3)Disconnect connector from G sensor. 4)Disconnect connector from ABSCM&H/U. 5)Measure voltage between ABSCM&H/U connector and chassis ground. <i>Connector & terminal (F49) No. 6 (+) — Chassis ground (-):</i>	Is the voltage less than 1 V?	Go to step 12.	Repair harness between G sensor and ABSCM&H/U.

DIAGNOSTICS CHART WITH SUBARU SELECT MONITOR

ABS (DIAGNOSTICS)

Step	Check	Yes	No
12 CHECK BATTERY SHORT OF HARNESS. 1) Turn ignition switch to ON. 2) Measure voltage between ABSCM&H/U connector and chassis ground. <i>Connector & terminal</i> <i>(F49) No. 6 (+) — Chassis ground (-):</i>	Is the voltage less than 1 V?	Go to step 13.	Repair harness between G sensor and ABSCM&H/U.
13 CHECK POOR CONTACT IN CONNECTORS.	Is there poor contact in connector between ABSCM&H/U and G sensor?	Repair connector.	Go to step 14.
14 CHECK ABSCM&H/U. 1) Connect all connectors. 2) Erase the memory. 3) Perform inspection mode. 4) Read out the trouble code.	Is the same trouble code as in the current diagnosis still being output?	Replace ABSCM&H/U. <Ref. to ABS-7, ABS Control Module and Hydraulic Control Unit (ABSCM&H/U).>	Go to step 15.
15 CHECK ANY OTHER TROUBLE CODES APPEARANCE.	Are other trouble codes being output?	Proceed with the diagnosis corresponding to the trouble code.	A temporary poor contact.
16 CHECK INPUT VOLTAGE OF G SENSOR. 1) Turn ignition switch to OFF. 2) Remove console box. 3) Disconnect G sensor from body. (Do not disconnect connector.) 4) Turn ignition switch to ON. 5) Measure voltage between G sensor connector terminals. <i>Connector & terminal</i> <i>(B292) No. 1 (+) — No. 3 (-):</i>	Is the voltage between 4.75 and 5.25 V?	Go to step 17.	Repair harness/connector between G sensor and ABSCM&H/U.
17 CHECK OPEN CIRCUIT IN G SENSOR OUTPUT HARNESS AND GROUND HARNESS. 1) Turn ignition switch to OFF. 2) Disconnect connector from ABSCM&H/U. 3) Measure resistance between ABSCM&H/U connector terminals. <i>Connector & terminal</i> <i>(F49) No. 6 — No. 28:</i>	Is the resistance between 4.3 and 4.9 kΩ?	Go to step 18.	Repair harness/connector between G sensor and ABSCM&H/U.
18 CHECK G SENSOR. 1) Connect connector to G sensor. 2) Connect connector to ABSCM&H/U. 3) Turn ignition switch to ON. 4) Measure voltage between G sensor connector terminals. <i>Connector & terminal</i> <i>(B292) No. 2 (+) — No. 3 (-):</i>	Is the voltage between 2.1 and 2.5 V when G sensor is horizontal?	Go to step 19.	Replace G sensor. <Ref. to ABS-22, G Sensor.>
19 CHECK G SENSOR. Measure voltage between G sensor connector terminals. <i>Connector & terminal</i> <i>(B292) No. 2 (+) — No. 3 (-):</i>	Is the voltage between 3.7 and 4.1 V when G sensor is inclined forwards to 90°?	Go to step 20.	Replace G sensor. <Ref. to ABS-22, G Sensor.>
20 CHECK G SENSOR. Measure voltage between G sensor connector terminals. <i>Connector & terminal</i> <i>(B292) No. 2 (+) — No. 3 (-):</i>	Is the voltage between 0.5 and 0.9 V when G sensor is inclined backwards to 90°?	Go to step 21.	Replace G sensor. <Ref. to ABS-22, G Sensor.>
21 CHECK POOR CONTACT IN CONNECTORS. Turn ignition switch to OFF.	Is there poor contact in connector between ABSCM&H/U and G sensor?	Repair connector.	Go to step 22.

DIAGNOSTICS CHART WITH SUBARU SELECT MONITOR

ABS (DIAGNOSTICS)

Step	Check	Yes	No
22 CHECK ABSCM&H/U. 1)Connect all connectors. 2)Erase the memory. 3)Perform inspection mode. 4)Read out the trouble code.	Is the same trouble code as in the current diagnosis still being output?	Replace ABSCM&H/U. <Ref. to ABS-7, ABS Control Module and Hydraulic Control Unit (ABSCM&H/U).>	Go to step 23 .
23 CHECK ANY OTHER TROUBLE CODES APPEARANCE.	Are other trouble codes being output?	Proceed with the diagnosis corresponding to the trouble code.	A temporary poor contact.

DIAGNOSTICS CHART WITH SUBARU SELECT MONITOR

ABS (DIAGNOSTICS)

DIAGNOSTICS CHART WITH SUBARU SELECT MONITOR

ABS (DIAGNOSTICS)

AG:TROUBLE CODE 56

— ABNORMAL G SENSOR HIGH μ OUTPUT —

DIAGNOSIS:

- Faulty G sensor output voltage

TROUBLE SYMPTOM:

- ABS does not operate.

WIRING DIAGRAM: LHD MODEL

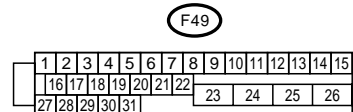
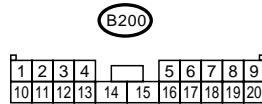
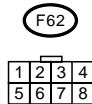
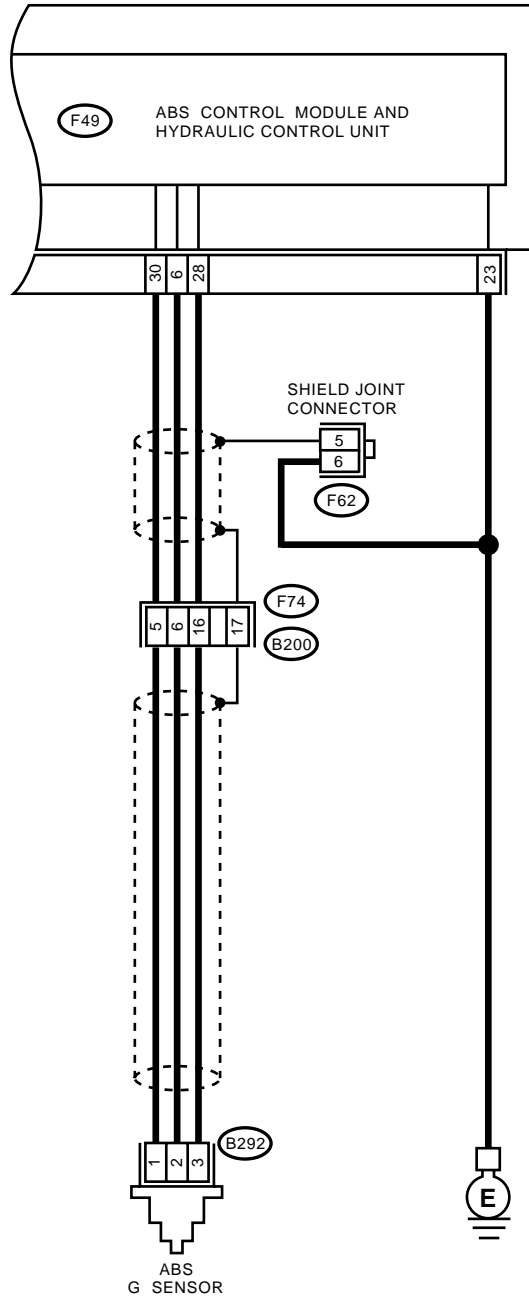

BR0044

DIAGNOSTICS CHART WITH SUBARU SELECT MONITOR

ABS (DIAGNOSTICS)

WIRING DIAGRAM: RHD MODEL

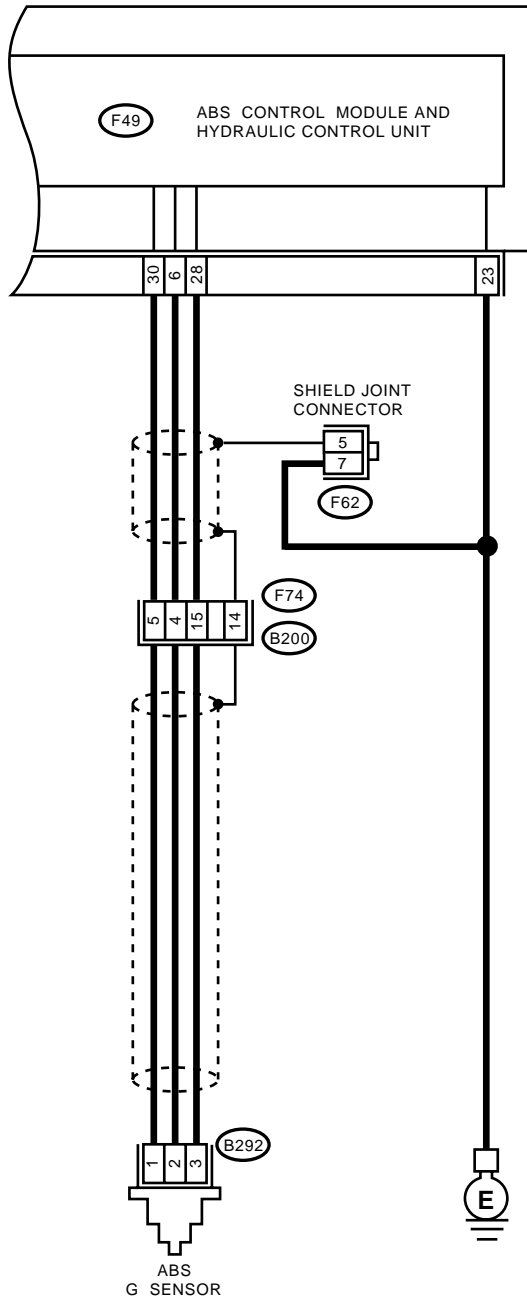

(B292)



(F62)



(F74)

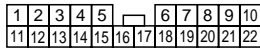

(F49)

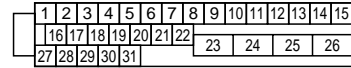

BR0045

DIAGNOSTICS CHART WITH SUBARU SELECT MONITOR

ABS (DIAGNOSTICS)

	Step	Check	Yes	No
1	CHECK OUTPUT OF G SENSOR USING SELECT MONITOR. 1) Select "Current data display & Save" on the select monitor. 2) Read G sensor output on the select monitor display.	Is the G sensor output on monitor display 2.3 ± 0.2 V when the G sensor is in horizontal position?	Go to step 2.	Go to step 6.
2	CHECK POOR CONTACT IN CONNECTORS. Turn ignition switch to OFF.	Is there poor contact in connector between ABSCM&H/U and G sensor?	Repair connector.	Go to step 3.
3	CHECK ABSCM&H/U. 1) Connect all connectors. 2) Erase the memory. 3) Perform inspection mode. 4) Read out the trouble code.	Is the same trouble code as in the current diagnosis still being output?	Replace ABSCM&H/U. <Ref. to ABS-7, ABS Control Module and Hydraulic Control Unit (ABSCM&H/U).>	Go to step 4.
4	CHECK ANY OTHER TROUBLE CODES APPEARANCE.	Are other trouble codes being output?	Proceed with the diagnosis corresponding to the trouble code.	A temporary poor contact.
5	CHECK OPEN CIRCUIT IN G SENSOR OUTPUT HARNESS AND GROUND HARNESS. 1) Turn ignition switch to OFF. 2) Disconnect connector from ABSCM&H/U. 3) Measure resistance between ABSCM&H/U connector terminals. <i>Connector & terminal (F49) No. 6 — No. 28:</i>	Is the resistance between 4.3 and 4.9 k Ω ?	Go to step 6.	Repair harness/connector between G sensor and ABSCM&H/U.
6	CHECK GROUND SHORT OF HARNESS. Measure resistance between ABSCM&H/U connector and chassis ground. <i>Connector & terminal (F49) No. 28 — Chassis ground:</i>	Is the resistance more than 1 M Ω ?	Go to step 7.	Repair harness between G sensor and ABSCM&H/U. Replace ABSCM&H/U. <Ref. to ABS-7, ABS Control Module and Hydraulic Control Unit (ABSCM&H/U).>
7	CHECK G SENSOR. 1) Remove console box. 2) Remove G sensor from vehicle. 3) Connect connector to G sensor. 4) Connect connector to ABSCM&H/U. 5) Turn ignition switch to ON. 6) Measure voltage between G sensor connector terminals. <i>Connector & terminal (B292) No. 2 (+) — No. 3 (-):</i>	Is the voltage between 2.1 and 2.5 V when G sensor is horizontal?	Go to step 8.	Replace G sensor. <Ref. to ABS-22, G Sensor.>
8	CHECK G SENSOR. Measure voltage between G sensor connector terminals. <i>Connector & terminal (B292) No. 2 (+) — No. 3 (-):</i>	Is the voltage between 3.7 and 4.1 V when G sensor is inclined forwards to 90°?	Go to step 9.	Replace G sensor. <Ref. to ABS-22, G Sensor.>
9	CHECK G SENSOR. Measure voltage between G sensor connector terminals. <i>Connector & terminal (B292) No. 2 (+) — No. 3 (-):</i>	Is the voltage between 0.5 and 0.9 V when G sensor is inclined backwards to 90°?	Go to step 10.	Replace G sensor. <Ref. to ABS-22, G Sensor.>

DIAGNOSTICS CHART WITH SUBARU SELECT MONITOR

ABS (DIAGNOSTICS)

Step	Check	Yes	No
10 CHECK ABSCM&H/U. 1)Turn ignition switch to OFF. 2)Connect all connectors. 3)Erase the memory. 4)Perform inspection mode. 5)Read out the trouble code.	Is the same trouble code as in the current diagnosis still being output?	Replace ABSCM&H/U. <Ref. to ABS-7, ABS Control Module and Hydraulic Control Unit (ABSCM&H/U).>	Go to step 11.
11 CHECK ANY OTHER TROUBLE CODES APPEARANCE.	Are other trouble codes being output?	Proceed with the diagnosis corresponding to the trouble code.	A temporary poor contact.

DIAGNOSTICS CHART WITH SUBARU SELECT MONITOR

ABS (DIAGNOSTICS)

AH:TROUBLE CODE 56 — DETECTION OF G SENSOR STICK —

DIAGNOSIS:

- Faulty G sensor output voltage

TROUBLE SYMPTOM:

- ABS does not operate.

WIRING DIAGRAM: LHD MODEL

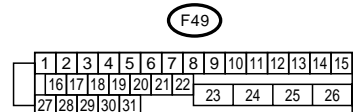
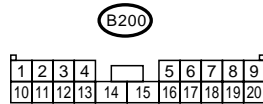
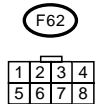
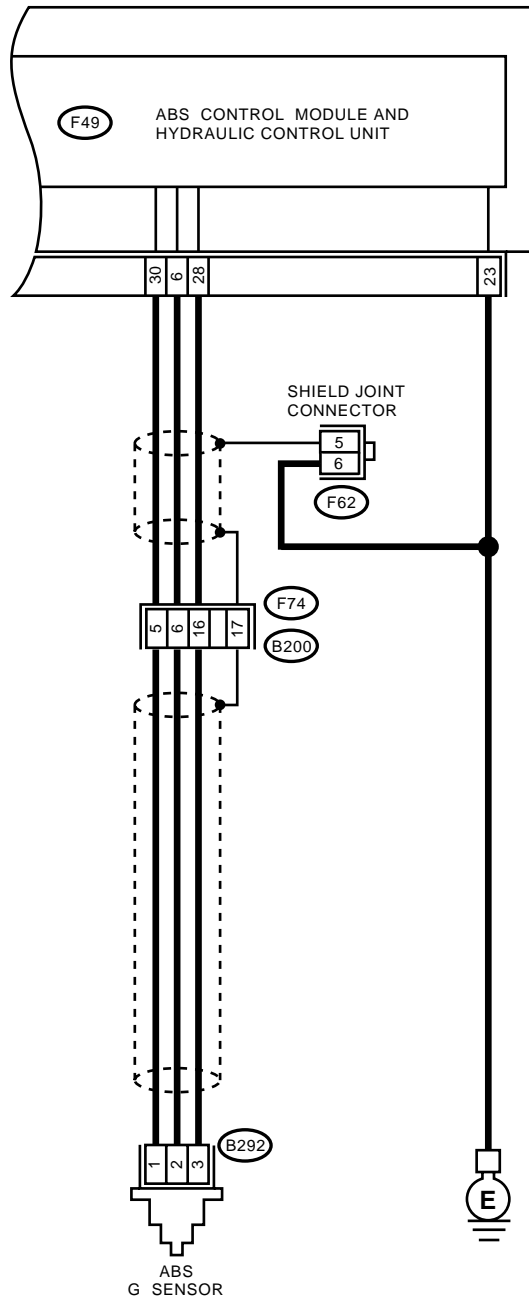

BR0044

DIAGNOSTICS CHART WITH SUBARU SELECT MONITOR

ABS (DIAGNOSTICS)

WIRING DIAGRAM: RHD MODEL

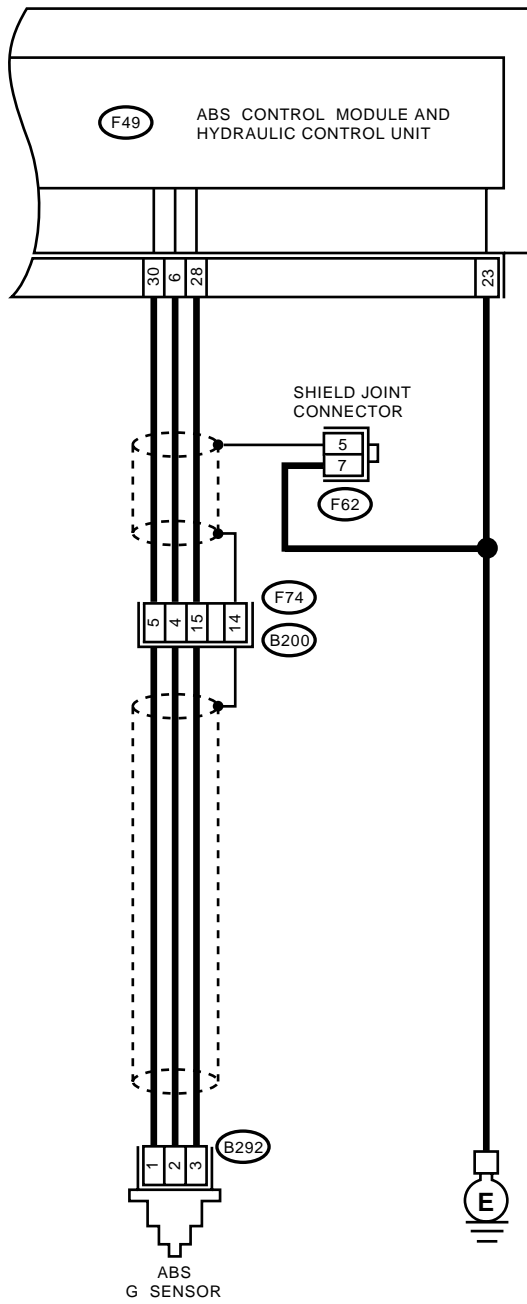

(B292)



(F62)



(F74)

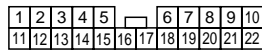

(F49)

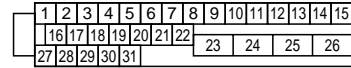

BR0045

DIAGNOSTICS CHART WITH SUBARU SELECT MONITOR

ABS (DIAGNOSTICS)

Step	Check	Yes	No	
1	CHECK ALL FOUR WHEELS FOR FREE TURNING.	Have the wheels been turned freely such as when the vehicle is lifted up, or operated on a rolling road?	The ABS is normal. Erase the trouble code.	Go to step 2.
2	CHECK OUTPUT OF G SENSOR USING SELECT MONITOR. 1) Select "Current data display & Save" on the select monitor. 2) Read the select monitor display.	Is the G sensor output on the monitor display between 2.1 and 2.5 V when the vehicle is in horizontal position?	Go to step 3.	Go to step 8.
3	CHECK OUTPUT OF G SENSOR USING SELECT MONITOR. 1) Turn ignition switch to OFF. 2) Remove console box. 3) Remove G sensor from vehicle. (Do not disconnect connector.) 4) Turn ignition switch to ON. 5) Select "Current data display & Save" on the select monitor. 6) Read the select monitor display.	Is the G sensor output on the monitor display between 3.7 and 4.1 V when G sensor is inclined forwards to 90°?	Go to step 4.	Replace G sensor. <Ref. to ABS-22, G Sensor.>
4	CHECK OUTPUT OF G SENSOR USING SELECT MONITOR. Read the select monitor display.	Is the G sensor output on the monitor display between 0.5 and 0.9 V when G sensor is inclined backwards to 90°?	Go to step 5.	Replace G sensor. <Ref. to ABS-22, G Sensor.>
5	CHECK POOR CONTACT IN CONNECTORS. Turn ignition switch to OFF.	Is there poor contact in connector between ABSCM&H/U and G sensor?	Repair connector.	Go to step 6.
6	CHECK ABSCM&H/U. 1) Connect all connectors. 2) Erase the memory. 3) Perform inspection mode. 4) Read out the trouble code.	Is the same trouble code as in the current diagnosis still being output?	Replace ABSCM&H/U. <Ref. to ABS-7, ABS Control Module and Hydraulic Control Unit (ABSCM&H/U).>	Go to step 7.
7	CHECK ANY OTHER TROUBLE CODES APPEARANCE.	Are other trouble codes being output?	Proceed with the diagnosis corresponding to the trouble code.	A temporary poor contact.
8	CHECK OPEN CIRCUIT IN G SENSOR OUTPUT HARNESS AND GROUND HARNESS. 1) Turn ignition switch to OFF. 2) Disconnect connector from ABSCM&H/U. 3) Measure resistance between ABSCM&H/U connector terminals. Connector & terminal (F49) No. 6 — No. 28:	Is the resistance between 4.3 and 4.9 kΩ?	Go to step 9.	Repair harness/connector between G sensor and ABSCM&H/U.
9	CHECK G SENSOR. 1) Remove console box. 2) Remove G sensor from vehicle. 3) Connect connector to G sensor. 4) Connect connector to ABSCM&H/U. 5) Turn ignition switch to ON. 6) Measure voltage between G sensor connector terminals. Connector & terminal (B292) No. 2 (+) — No. 3 (-):	Is the voltage between 2.1 and 2.5 V when G sensor is horizontal?	Go to step 10.	Replace G sensor. <Ref. to ABS-22, G Sensor.>

DIAGNOSTICS CHART WITH SUBARU SELECT MONITOR

ABS (DIAGNOSTICS)

Step	Check	Yes	No
10 CHECK G SENSOR. Measure voltage between G sensor connector terminals. <i>Connector & terminal</i> <i>(B292) No. 2 (+) — No. 3 (-):</i>	Is the voltage between 3.7 and 4.1 V when G sensor is inclined forwards to 90°?	Go to step 11.	Replace G sensor. <Ref. to ABS-22, G Sensor.>
11 CHECK G SENSOR. Measure voltage between G sensor connector terminals. <i>Connector & terminal</i> <i>(B292) No. 2 (+) — No. 3 (-):</i>	Is the voltage between 0.5 and 0.9 V when G sensor is inclined backwards to 90°?	Go to step 12.	Replace G sensor. <Ref. to ABS-22, G Sensor.>
12 CHECK ABSCM&H/U. 1) Turn ignition switch to OFF. 2) Connect all connectors. 3) Erase the memory. 4) Perform inspection mode. 5) Read out the trouble code.	Is the same trouble code as in the current diagnosis still being output?	Replace ABSCM&H/U. <Ref. to ABS-7, ABS Control Module and Hydraulic Control Unit (ABSCM&H/U).>	Go to step 13.
13 CHECK ANY OTHER TROUBLE CODES APPEARANCE.	Are other trouble codes being output?	Proceed with the diagnosis corresponding to the trouble code.	A temporary poor contact.

GENERAL DIAGNOSTICS TABLE

ABS (DIAGNOSTICS)

14. General Diagnostics Table

A: INSPECTION

Symptom		Probable faulty units/parts
Vehicle instability during braking	Vehicle pulls to either side.	<ul style="list-style-type: none"> • ABSCM&H/U (solenoid valve) • ABS sensor • Brake (caliper & piston, pads) • Wheel alignment • Tire specifications, tire wear and air pressures • Incorrect wiring or piping connections • Road surface (uneven, camber)
	Vehicle spins.	<ul style="list-style-type: none"> • ABSCM&H/U (solenoid valve) • ABS sensor • Brake (pads) • Tire specifications, tire wear and air pressures • Incorrect wiring or piping connections
Poor braking	Long braking/stopping distance	<ul style="list-style-type: none"> • ABSCM&H/U (solenoid valve) • Brake (pads) • Air in brake line • Tire specifications, tire wear and air pressures • Incorrect wiring or piping connections
	Wheel locks.	<ul style="list-style-type: none"> • ABSCM&H/U (solenoid valve, motor) • ABS sensor • Incorrect wiring or piping connections
	Brake dragging	<ul style="list-style-type: none"> • ABSCM&H/U (solenoid valve) • ABS sensor • Master cylinder • Brake (caliper & piston) • Parking brake • Axle & wheels • Brake pedal play
	Long brake pedal stroke	<ul style="list-style-type: none"> • Air in brake line • Brake pedal play
	Vehicle pitching	<ul style="list-style-type: none"> • Suspension play or fatigue (reduced damping) • Incorrect wiring or piping connections • Road surface (uneven)
	Unstable or uneven braking	<ul style="list-style-type: none"> • ABSCM&H/U (solenoid valve) • ABS sensor • Brake (caliper & piston, pads) • Tire specifications, tire wear and air pressures • Incorrect wiring or piping connections • Road surface (uneven)

GENERAL DIAGNOSTICS TABLE

ABS (DIAGNOSTICS)

Symptom	Probable faulty units/parts	
Vibration and/or noise (while driving on slippery roads)	Excessive pedal vibration	<ul style="list-style-type: none"> • Incorrect wiring or piping connections • Road surface (uneven)
	Noise from ABSCM&H/U	<ul style="list-style-type: none"> • ABSCM&H/U (mount bushing) • ABS sensor • Brake piping
	Noise from front of vehicle	<ul style="list-style-type: none"> • ABSCM&H/U (mount bushing) • ABS sensor • Master cylinder • Brake (caliper & piston, pads, rotor) • Brake piping • Brake booster & check valve • Suspension play or fatigue
	Noise from rear of vehicle	<ul style="list-style-type: none"> • ABS sensor • Brake (caliper & piston, pads, rotor) • Parking brake • Brake piping • Suspension play or fatigue

GENERAL DIAGNOSTICS TABLE

ABS (DIAGNOSTICS)
