

**ENGINE 1 SECTION**

This service manual has been prepared to provide SUBARU service personnel with the necessary information and data for the correct maintenance and repair of SUBARU vehicles.

This manual includes the procedures for maintenance, disassembling, reassembling, inspection and adjustment of components and diagnostics for guidance of experienced mechanics.

Please peruse and utilize this manual fully to ensure complete repair work for satisfying our customers by keeping their vehicle in optimum condition. When replacement of parts during repair work is needed, be sure to use SUBARU genuine parts.

All information, illustration and specifications contained in this manual are based on the latest product information available at the time of publication approval.

**FUEL INJECTION (FUEL SYSTEMS) FU(SOHC)**

**EMISSION CONTROL (AUX. EMISSION CONTROL DEVICES) EC(SOHC)**

**INTAKE (INDUCTION) IN(SOHC)**

**MECHANICAL ME(SOHC)**

**EXHAUST EX(SOHC)**

**COOLING CO**

**LUBRICATION LU**

**SPEED CONTROL SYSTEMS SP**

**IGNITION IG(SOHC)**

**STARTING/CHARGING SYSTEMS SC**

**ENGINE (DIAGNOSTICS) EN(SOHC)**

# LUBRICATION

# *LU*

---

	<b>Page</b>
1. General Description .....	2
2. Oil Pressure System .....	7
3. Engine Oil.....	10
4. Oil Pump .....	12
5. Oil Pan and Strainer .....	16
6. Oil Pressure Switch.....	21
7. Engine Oil Cooler .....	23
8. Engine Oil Filter.....	25
9. Engine Lubrication System Trouble in General.....	26

# GENERAL DESCRIPTION

## LUBRICATION

### 1. General Description

#### A: SPECIFICATIONS

Lubrication method				Forced lubrication	
Oil pump	Pump type			Trochoid type	
	Number of teeth	Inner rotor		9	
		Outer rotor		10	
	Outer rotor diameter × thickness			78 × 9 mm (3.07 × 0.35 in)	
	Tip clearance between inner and outer rotor			STANDARD	0.04 — 0.14 mm (0.0016 — 0.0055 in)
				LIMIT	0.18 mm (0.0071 in)
	Side clearance between inner rotor and pump case			STANDARD	0.02 — 0.07 mm (0.0008 — 0.0028 in)
				LIMIT	0.12 mm (0.0047 in)
	Case clearance between outer rotor and pump case			STANDARD	0.10 — 0.175 mm (0.0039 — 0.0069 in)
				LIMIT	0.20 mm (0.0079 in)
	Capacity at 80°C (176°F)	700 rpm	Discharge	- pressure	98 kPa (1.0 kg/cm <sup>2</sup> , 14 psi)
- quantity				4.2 ℓ (4.4 US qt, 3.7 Imp qt)/min.	
5,000 rpm		Discharge	- pressure	294 kPa (3.0 kg/cm <sup>2</sup> , 43 psi)	
			- quantity	42.0 ℓ (11.10 US gal, 9.24 Imp gal)/min.	
Relief valve operation pressure				490 kPa (5.0 kg/cm <sup>2</sup> , 71 psi)	
Oil filter	Type			Full-flow filter type	
	Filtration area			1,000 cm <sup>2</sup> (155 sq in)	
	By-pass valve opening pressure			157 kPa (1.6 kg/cm <sup>2</sup> , 23 psi)	
	Outer diameter × width			80 × 70 mm (3.15 × 2.76 in)	
	Oil filter to engine thread size			M 20 × 1.5	
Relief valve (on rocker shaft) operation pressure				69 kPa (0.7kg/cm <sup>2</sup> , 10 psi)	
Oil pressure switch	Type			Immersed contact point type	
	Working voltage — wattage			12 V — 3.4 W or less	
	Warning light activation pressure			14.7 kPa (0.15 kg/cm <sup>2</sup> , 2.1 psi)	
	Proof pressure			More than 981 kPa (10 kg/cm <sup>2</sup> , 142 psi)	
Oil capacity (at replacement)		Non-Turbo model		4.0 ℓ (4.2 US qt, 3.5 Imp qt)	
		Turbo model		4.5 ℓ (4.8 US qt, 4.0 Imp qt)	

## B: COMPONENT

### 1. NON-TURBO MODEL

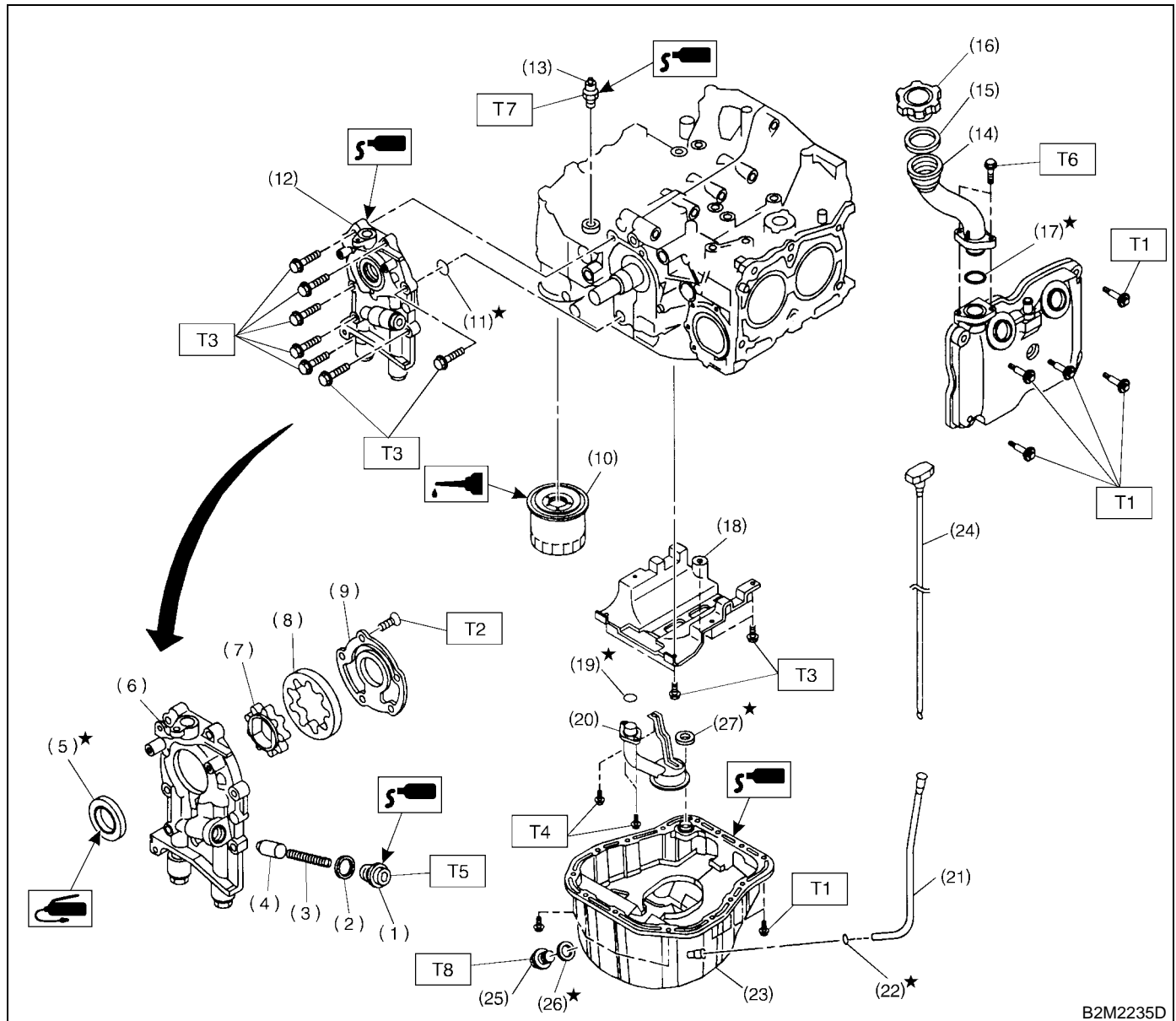

B2M2235D

- |                          |                            |
|--------------------------|----------------------------|
| (1) Plug                 | (14) Oil filler duct       |
| (2) Washer               | (15) O-ring                |
| (3) Relief valve spring  | (16) Oil filler cap        |
| (4) Relief valve         | (17) O-ring                |
| (5) Oil seal             | (18) Baffle plate          |
| (6) Oil pump case        | (19) O-ring                |
| (7) Inner rotor          | (20) Oil strainer          |
| (8) Outer rotor          | (21) Oil level gauge guide |
| (9) Oil pump cover       | (22) O-ring                |
| (10) Oil filter          | (23) Oil pan               |
| (11) O-ring              | (24) Oil level gauge       |
| (12) Oil pump ASSY       | (25) Drain plug            |
| (13) Oil pressure switch | (26) Metal gasket          |

- (27) Gasket

**Tightening torque: N·m (kgf·m, ft·lb)**

- T1: 5 (0.5, 3.6)**  
**T2: 5 (0.5, 3.6)**  
**T3: 6.4 (0.65, 4.7)**  
**T4: 10 (1.0, 7.2)**  
**T5: 44.1 (4.5, 32.5)**  
**T6: 6.4 (0.65, 4.7)**  
**T7: 25 (2.5, 18.1)**  
**T8: 44 (4.5, 33)**

# GENERAL DESCRIPTION

## LUBRICATION

### 2. TURBO MODEL

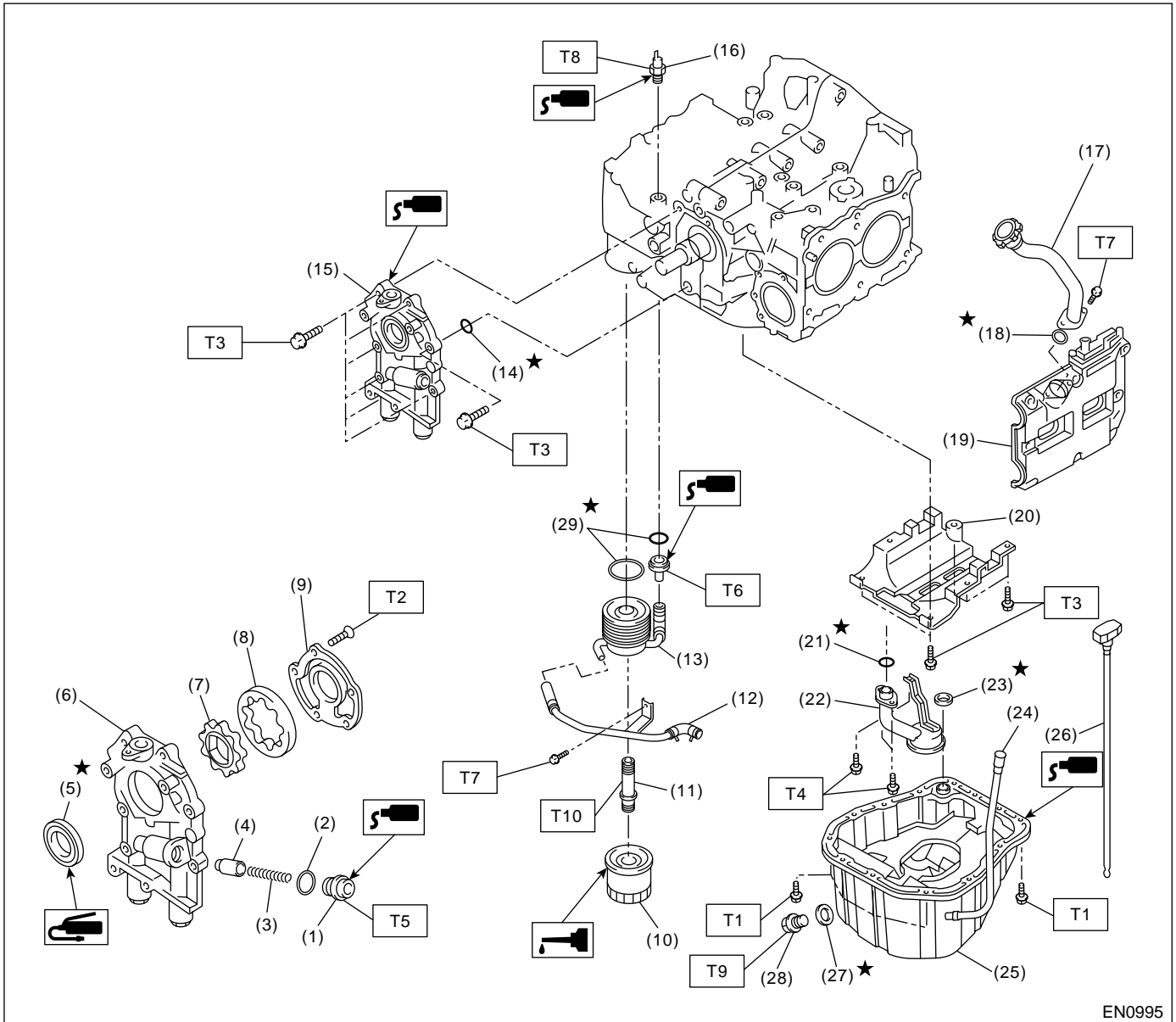

EN0995

- |                         |                            |             |
|-------------------------|----------------------------|-------------|
| (1) Plug                | (15) Oil pump ASSY         | (29) O-ring |
| (2) Washer              | (16) Oil pressure switch   |             |
| (3) Relief valve spring | (17) Oil filler duct       |             |
| (4) Relief valve        | (18) O-ring                |             |
| (5) Oil seal            | (19) Cylinder head cover   |             |
| (6) Oil pump case       | (20) Baffle plate          |             |
| (7) Inner rotor         | (21) O-ring                |             |
| (8) Outer rotor         | (22) Oil strainer          |             |
| (9) Oil pump cover      | (23) Gasket                |             |
| (10) Oil filter         | (24) Oil level gauge guide |             |
| (11) Connector          | (25) Oil pan               |             |
| (12) Water by-pass pipe | (26) Oil level gauge       |             |
| (13) Oil cooler         | (27) Metal gasket          |             |
| (14) O-ring             | (28) Drain plug            |             |

#### **Tightening torque: N·m (kgf·m, ft·lb)**

**T1: 5 (0.5, 3.6)**

**T2: 5 (0.5, 3.6)**

**T3: 6.4 (0.65, 4.7)**

**T4: 10 (1.0, 7.0)**

**T5: 44.1 (4.5, 32.5)**

**T6: 69 (7.0, 4.7)**

**T7: 6.4 (0.65, 50.6)**

**T8: 25 (2.5, 18.1)**

**T9: 44 (4.5, 33)**

**T10: 54 (5.5, 40)**

### **C: CAUTION**

- Wear working clothing, including a cap, protective goggles, and protective shoes during operation.
- Remove contamination including dirt and corrosion before removal, installation or disassembly.
- Keep the disassembled parts in order and protect them from dust or dirt.
- Before removal, installation or disassembly, be sure to clarify the failure. Avoid unnecessary removal, installation, disassembly, and replacement.
- Be careful not to burn your hands, because each part in the vehicle is hot after running.
- Be sure to tighten fasteners including bolts and nuts to the specified torque.
- Place shop jacks or safety stands at the specified points.
- Before disconnecting electrical connectors of sensors or units, be sure to disconnect negative terminal from battery.

# GENERAL DESCRIPTION

LUBRICATION

## D: PREPARATION TOOL

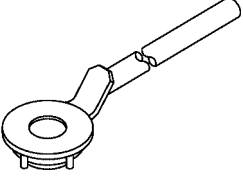
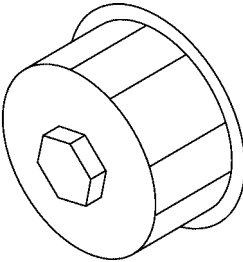
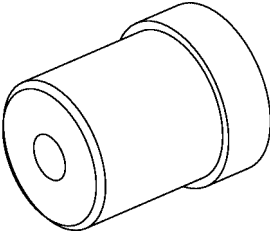
ILLUSTRATION	TOOL NUMBER	DESCRIPTION	REMARKS
 B2M4157	499977300	CRANK PULLEY WRENCH	Used for stopping rotation of crankshaft pulley when loosening and tightening crankshaft pulley bolt.
 B2M3872	498547000	OIL FILTER WRENCH	Used for removing and installing oil filter.
 B2M3875	499587100	OIL SEAL INSTALLER	Used for installing oil pump oil seal.

## 2. Oil Pressure System

### A: SCHEMATIC

#### 1. NON-TURBO MODEL

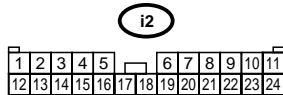
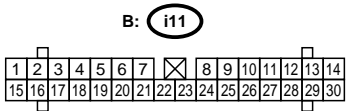
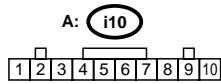
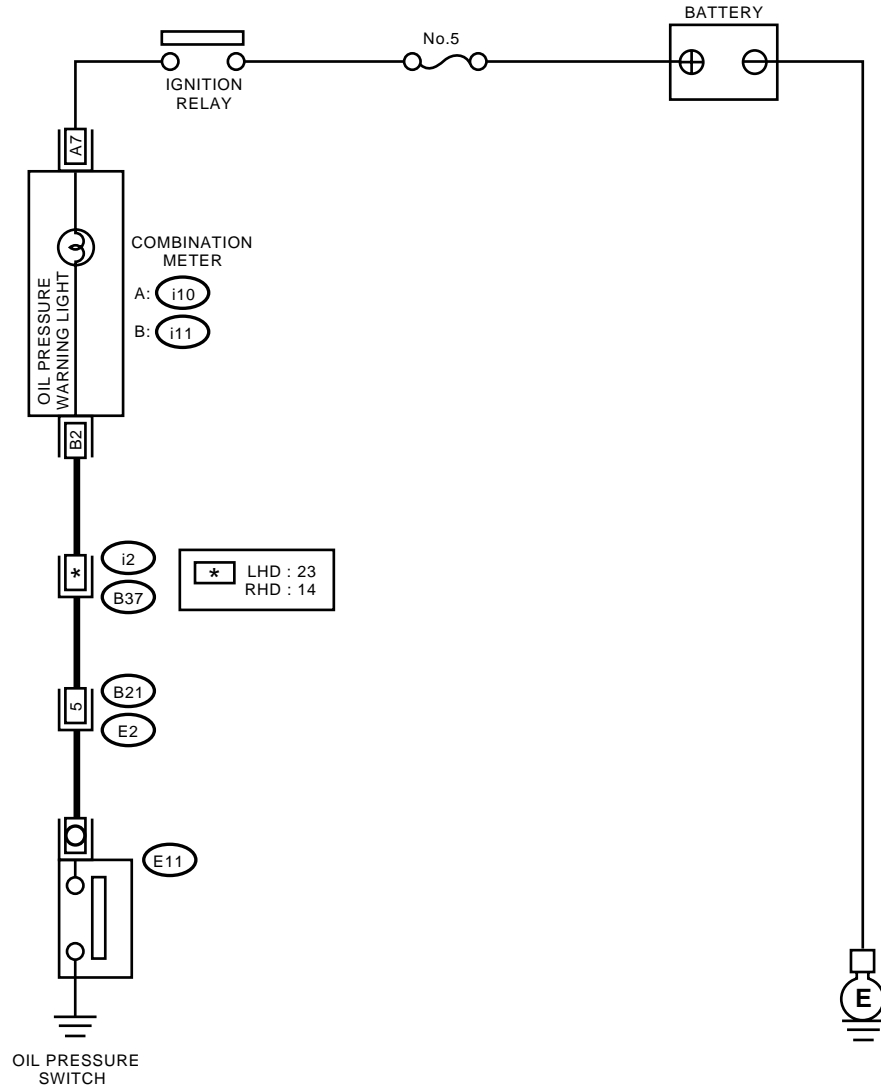

(LHD)

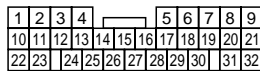

(RHD)

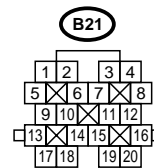

EN0997



# OIL PRESSURE SYSTEM

LUBRICATION

## 2. TURBO MODEL

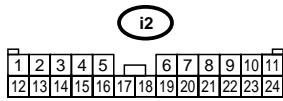
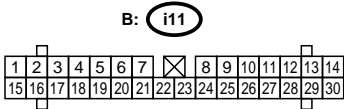
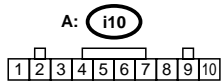
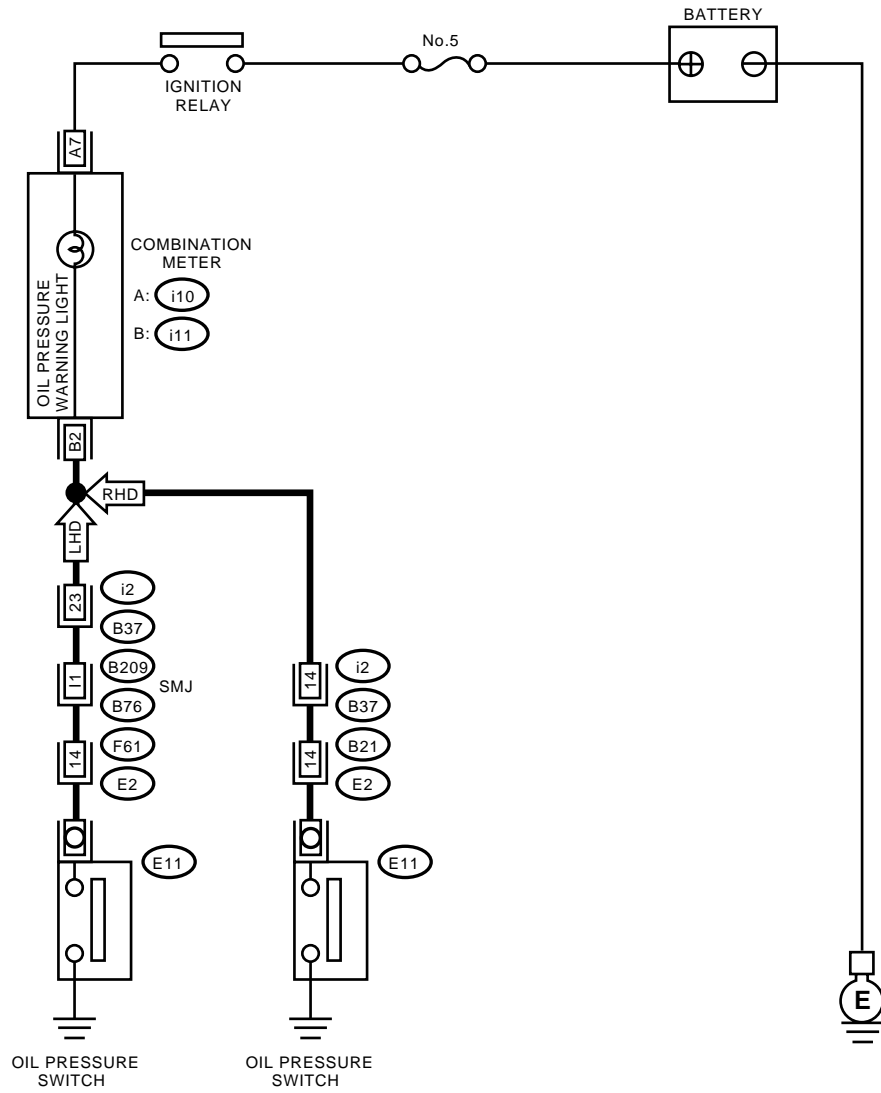

(LHD)

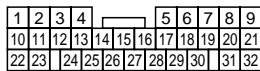

(RHD)

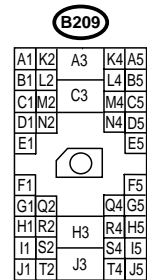
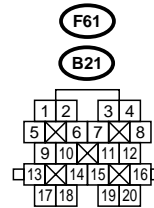

EN0996

## B: INSPECTION

Step	Check	Yes	No
<b>1</b> <b>CHECK COMBINATION METER.</b> 1) Turn ignition switch to ON. (engine OFF) 2) Check other warning lights.	Does the warning lights go on?	Go to step 2.	Repair or replace the combination meter. <Ref. to IDI-10, INSPECTION, Combination Meter System.>
<b>2</b> <b>CHECK HARNESS CONNECTOR BETWEEN COMBINATION METER AND OIL PRESSURE SWITCH.</b> 1) Turn ignition switch to OFF. 2) Disconnect connector from the oil pressure switch. 3) Turn ignition switch ON. 4) Measure the voltage of harness between the combination meter connector and chassis ground. <i>Connector &amp; terminal</i> <i>(E11) No. 1 — Chassis ground:</i>	Is the voltage more than 10 V?	Replace oil pressure switch.	Go to step 3.
<b>3</b> <b>CHECK COMBINATION METER.</b> 1) Turn ignition switch to OFF. 2) Remove the combination meter. 3) Measure the resistance of the combination meter. <i>Terminal</i> <i>No. A7 — No. B2:</i>	Is the resistance less than 10 $\Omega$ ?	Replace the harness connector between combination meter and oil pressure switch.	Repair or replace the combination meter and the oil pressure switch warning light bulb.

## 3. Engine Oil

### A: INSPECTION

- 1) Park vehicle on a level surface.
- 2) Remove oil level gauge and wipe it clean.
- 3) Reinsert the level gauge all the way. Be sure that the level gauge is correctly inserted and in the proper orientation.
- 4) Remove it again and note the reading. If the engine oil level is below the "L" line, add oil to bring the level up to the "F" line.
- 5) After turning off the engine, wait a few minutes for the oil to drain back into the oil pan before checking the level.
- 6) Just after driving or while the engine is warm, engine oil level may show in the range between the "F" line and the notch mark. This is caused by thermal expansion of the engine oil.
- 7) To prevent overfilling the engine oil, do not add oil above the "F" line when the engine is cold.

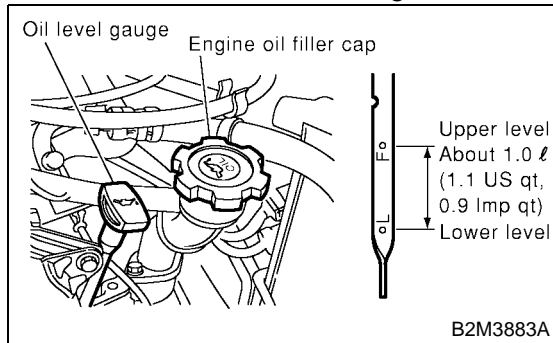

### B: REPLACEMENT

- 1) Drain engine oil by loosening engine oil drain plug.

- Non-Turbo model

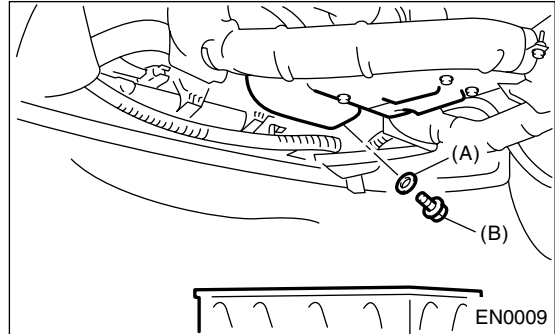

- Turbo model

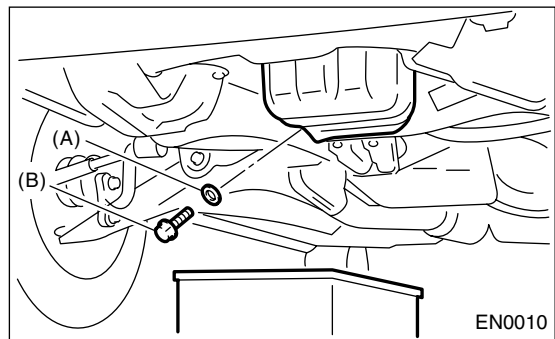

- (A) Gasket  
(B) Drain plug

- 2) Open engine oil filler cap for quick draining of the engine oil.

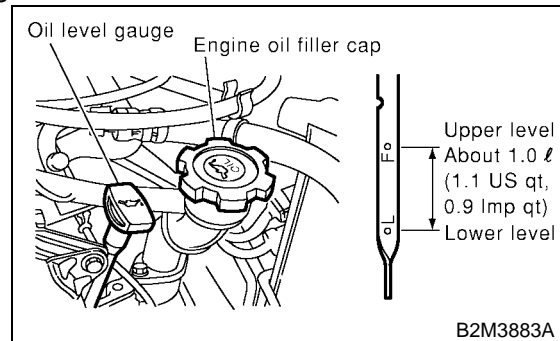

- 3) Replace drain plug gasket.

4) Tighten engine oil drain plug after draining engine oil.

**Tightening torque:**

**44 N·m (4.5 kgf·m, 33 ft·lb)**

- Non-Turbo model

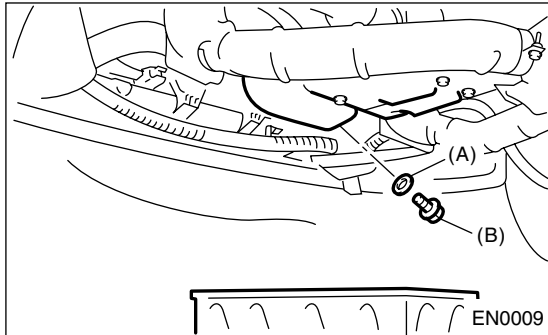

- Turbo model

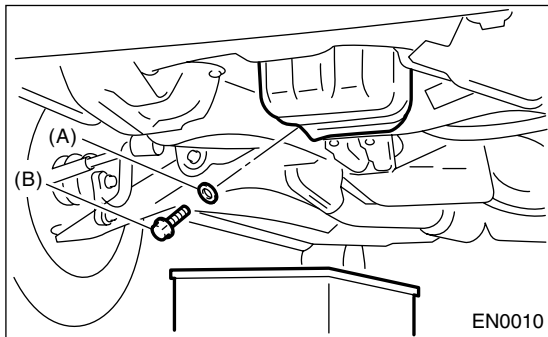

- (A) Gasket
- (B) Drain plug

5) Fill engine oil through filler pipe up to upper point on level gauge. Make sure that vehicle is placed level when checking oil level. Use engine oil of proper quality and viscosity, selected in accordance with the table in figure.

**Recommended oil**

**API classification**

**SJ or SH with the words “Energy Conserving or Energy conserving II”, CCMC specification G4 or G5, ACEA specification A1, A2 or A3, or New API mark displayed on the container (If it is impossible to get SJ or SH grade, you may use SG grade.)**

**Engine oil capacity: (Non-Turbo model)**

**Upper level**

**4.0 ℓ (4.2 US qt, 3.5 Imp qt)**

**Lower level**

**3.0 ℓ (3.2 US qt, 2.6 Imp qt)**

**Engine oil capacity: (Turbo model)**

**Upper level**

**4.5 ℓ (4.8 US qt, 4.0 Imp qt)**

**Lower level**

**3.5 ℓ (3.7 US qt, 3.1 Imp qt)**

SAE Viscosity No. and Applicable Temperature							
(°C)	-30	-20	-15	0	15	30	40
(°F)	-22	-4	5	32	59	86	104
B2M3885A							

The proper viscosity helps vehicle get good cold and hot starting by reducing viscous friction and thus increasing cranking speed.

**CAUTION:**

**When replenishing oil, it does not matter if the oil to be added is a different brand from that in the engine; however, use oil having the API classification and SAE viscosity No. designated by SUBARU.**

**NOTE:**

If vehicle is used in desert areas with very high temperatures or for other heavy duty applications, the following viscosity oils may be used: API classification: SJ or SH

SAE Viscosity No.: 30, 40, 10W-50, 20W-40, 20W-50.

6) Close engine oil filler cap.

7) Start engine and warm it up for a time.

8) After engine stops, recheck the oil level. If necessary, add engine oil up to upper level on level gauge.

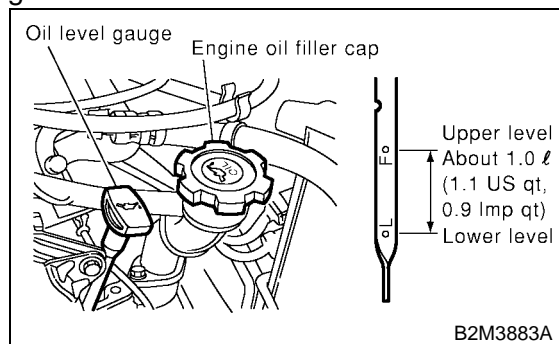

## 4. Oil Pump

### A: REMOVAL

1) Disconnect battery ground cable.

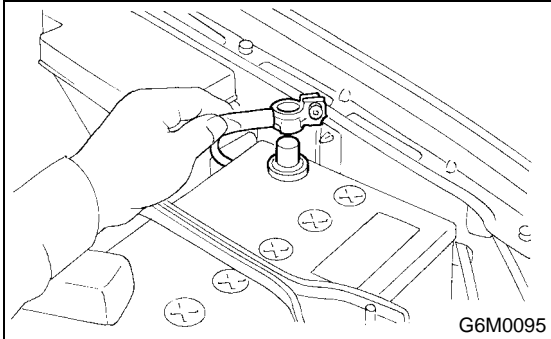

2) Lift-up the vehicle.

3) Remove under cover.

4) Remove bolts which install water pipe of oil cooler to oil pump. (Turbo model)

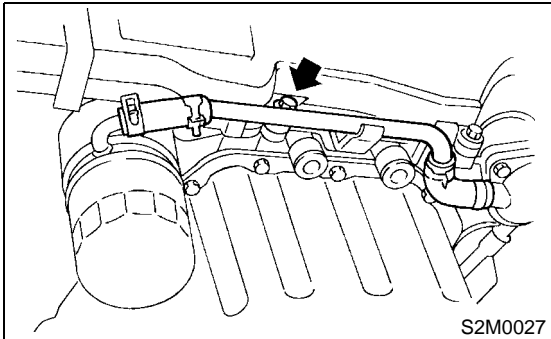

5) Remove water pipe and hoses between oil cooler and water pump. (Turbo model)

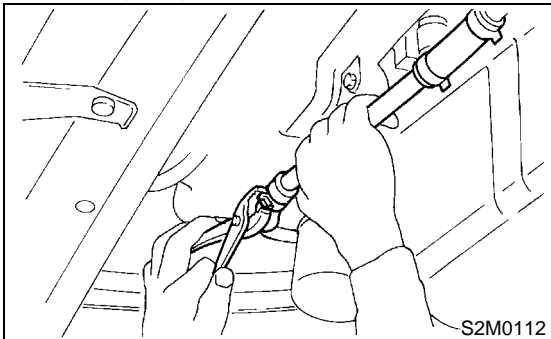

6) Remove radiator. <Ref. to CO-37, REMOVAL, Radiator.>

7) Remove crankshaft position sensor.

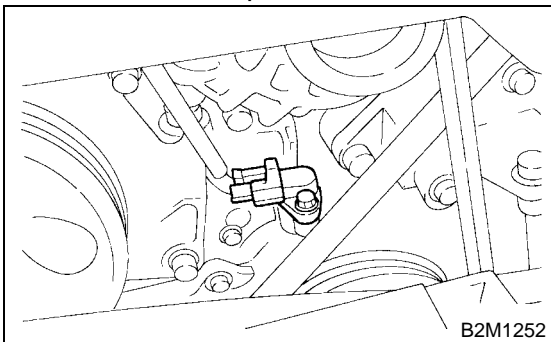

8) Remove V-belts. <Ref. to ME(SOHC)-42, REMOVAL, V-belt.> or <Ref. to ME(DOHC TURBO)-43, REMOVAL, V-belt.>

9) Remove rear side V-belt tensioner.

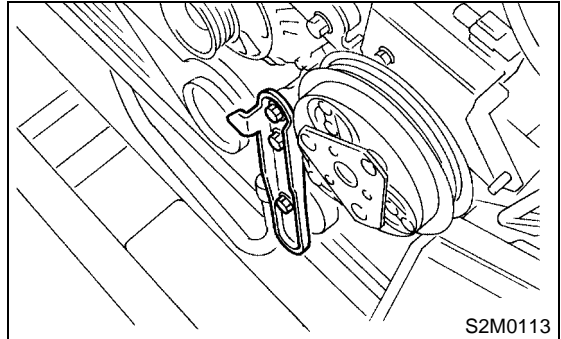

10) Remove crankshaft pulley by using ST.

ST 499977300 CRANKSHAFT PULLEY WRENCH

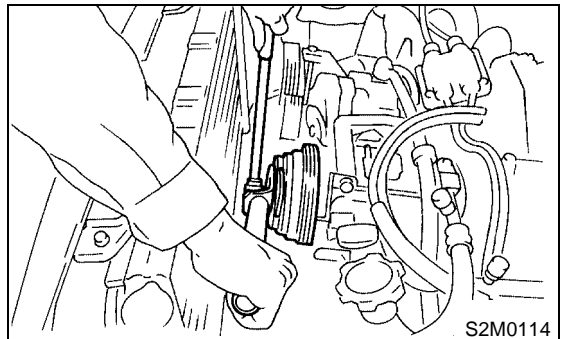

11) Remove water pump. <Ref. to CO-27, REMOVAL, Water Pump.>

12) Remove timing belt guide. (MT vehicles only)

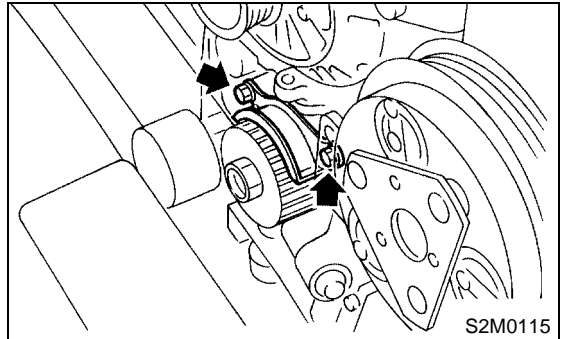

13) Remove crankshaft sprocket.

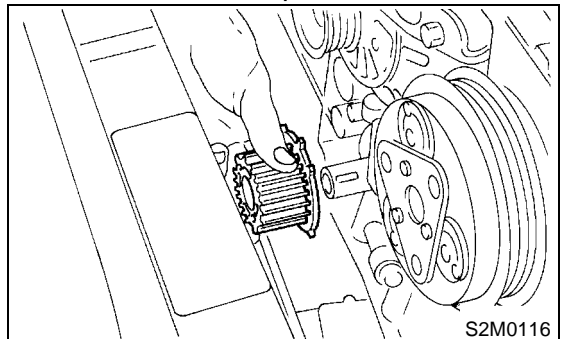

14) Remove bolts which install oil pump onto cylinder block.

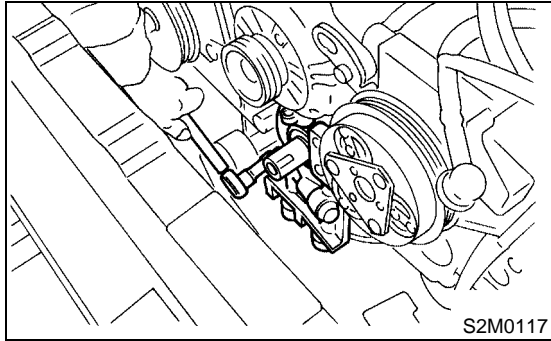

15) Remove oil pump by using flat bladed screwdriver.

**CAUTION:**  
Be careful not to scratch mating surfaces of cylinder block and oil pump.

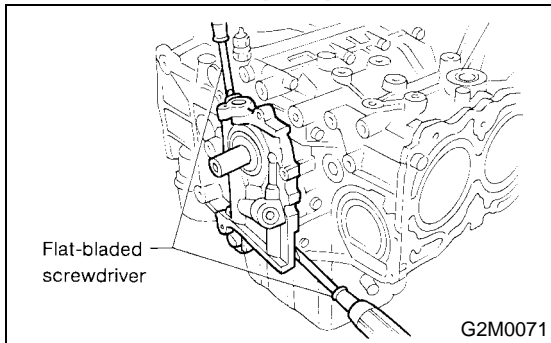

## B: INSTALLATION

Install in the reverse order of removal.

Do the following:

1) Apply fluid packing to matching surfaces of oil pump.

**Fluid packing:**

**THREE BOND 1215 or equivalent**

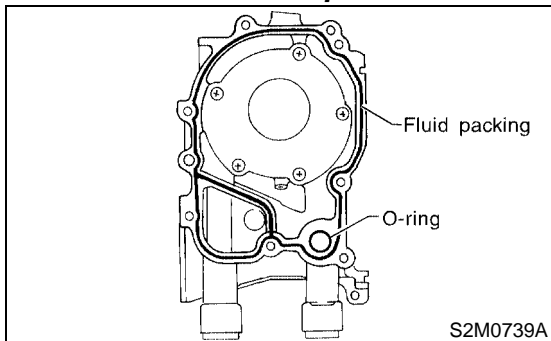

2) Replace O-ring with a new one.

3) Apply a coat of engine oil to the inside of the oil seal.

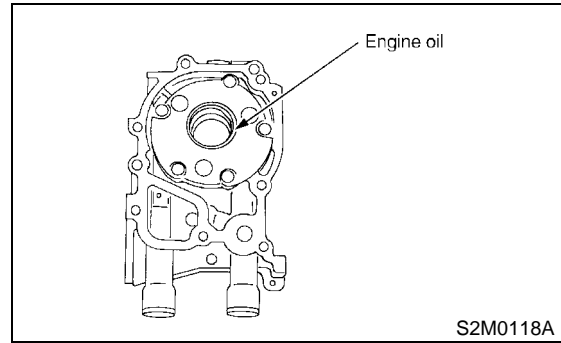

4) Be careful not to scratch oil seal when installing oil pump on cylinder block.

5) Position the oil pump, aligning the notched area with the crankshaft, and push the oil pump straight.

**CAUTION:**

**Make sure the oil seal lip is not folded.**

6) Install oil pump.

**Tightening torque:**

**6.4 N·m (0.65 kgf·m, 4.7 ft·lb)**

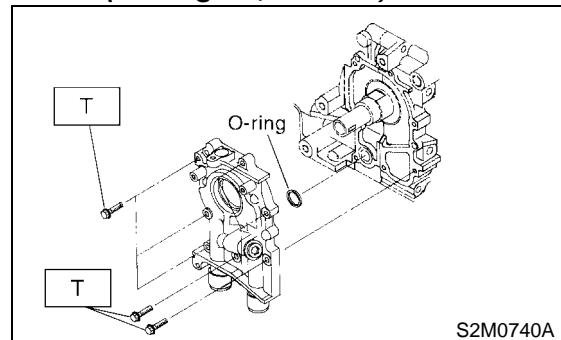

# OIL PUMP

## LUBRICATION

### C: DISASSEMBLY

Remove screws which secure oil pump cover and disassemble oil pump. Inscribe alignment marks on inner and outer rotors so that they can be replaced in their original positions during reassembly.

#### CAUTION:

**Before removing relief valve, loosen plug when removing oil pump from cylinder block.**

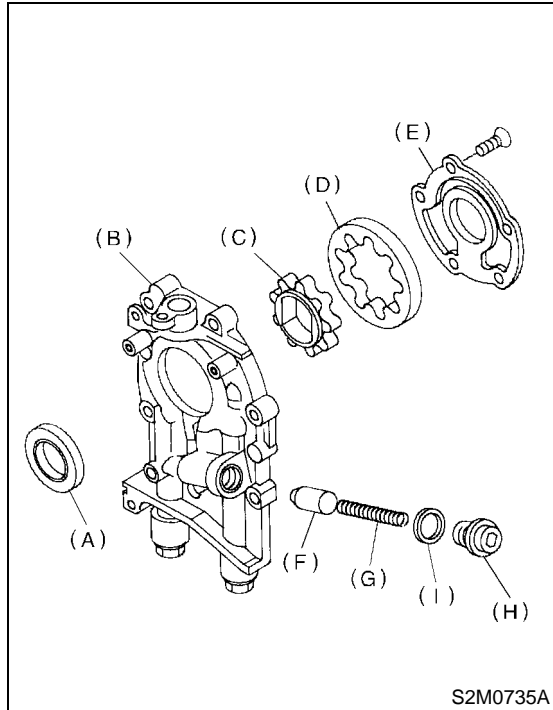

- (A) Oil seal
- (B) Pump case
- (C) Inner rotor
- (D) Outer rotor
- (E) Pump cover
- (F) Relief valve
- (G) Relief valve spring
- (H) Plug
- (I) Washer

### D: ASSEMBLY

- 1) Install front oil seal by using ST.  
ST 499587100 OIL SEAL INSTALLER

#### CAUTION:

**Use a new oil seal.**

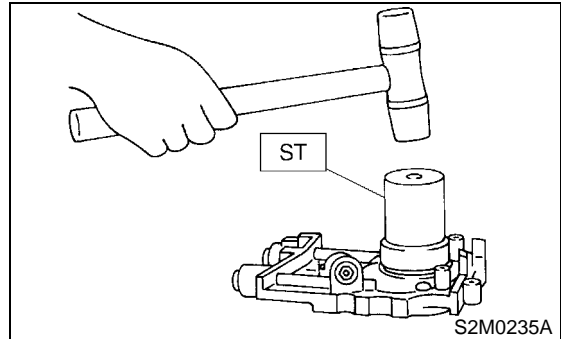

- 2) Apply a coat of engine oil to inner and outer rotors.
- 3) Install inner and outer rotors in their original positions.
- 4) Install oil relief valve and relief valve spring.
- 5) Install oil pump cover.

#### Tightening torque:

**T1: 5 N·m (0.5 kgf-m, 3.6 ft-lb)**

**T2: 44 N·m (4.5 kgf-m, 32.5 ft-lb)**

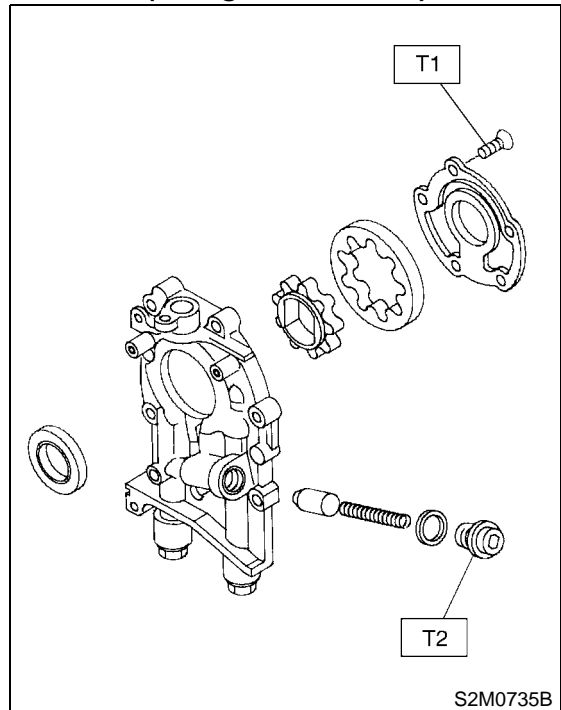

**E: INSPECTION****1. TIP CLEARANCE**

Measure the tip clearance of rotors. If the clearance exceeds the limit, replace rotors as a matched set.

**Tip clearance:****Standard**

**0.04 — 0.14 mm (0.0016 — 0.0055 in)**

**Limit**

**0.18 mm (0.0071 in)**

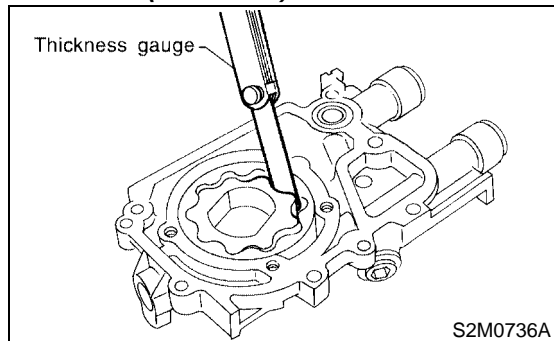
**2. CASE CLEARANCE**

Measure the clearance between the outer rotor and the cylinder block rotor housing. If the clearance exceeds the limit, replace the rotor.

**Case clearance:****Standard**

**0.10 — 0.175 mm (0.0039 — 0.0069 in)**

**Limit**

**0.20 mm (0.0079 in)**

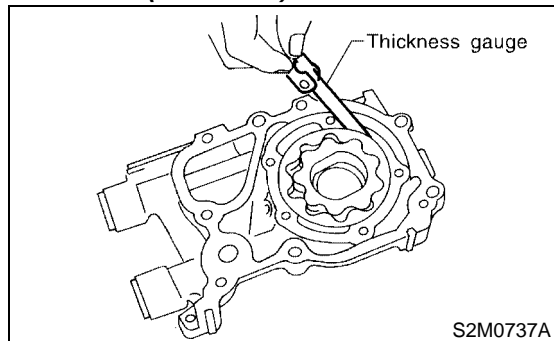
**3. SIDE CLEARANCE**

Measure clearance between oil pump inner rotor and pump cover. If the clearance exceeds the limit, replace rotor or pump body.

**Side clearance:****Standard**

**0.02 — 0.07 mm (0.0008 — 0.0028 in)**

**Limit**

**0.12 mm (0.0047 in)**

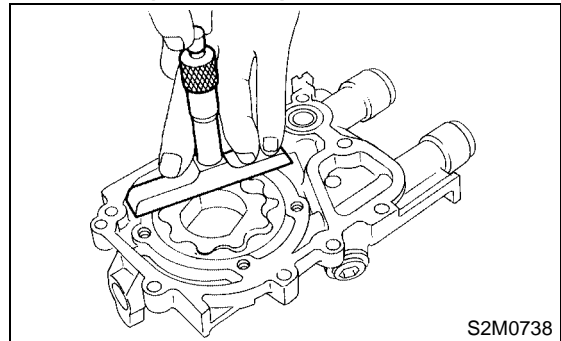
**4. OIL RELIEF VALVE**

Check the valve for fitting condition and damage, and the relief valve spring for damage and deterioration. Replace the parts if defective.

**Relief valve spring:****Free length**

**71.8 mm (2.827 in)**

**Installed length**

**54.7 mm (2.154 in)**

**Load when installed**

**77.08 N (7.86 kg, 17.33 lb)**

**5. OIL PUMP CASE**

Check the oil pump case for worn shaft hole, clogged oil passage, worn rotor chamber, cracks, and other faults.

**6. OIL SEAL**

Check the oil seal lips for deformation, hardening, wear, etc. and replace if defective.



## 5. Oil Pan and Strainer

### A: REMOVAL

- 1) Set the vehicle on lift arms.
- 2) Remove front wheels.
- 3) Disconnect battery ground cable.

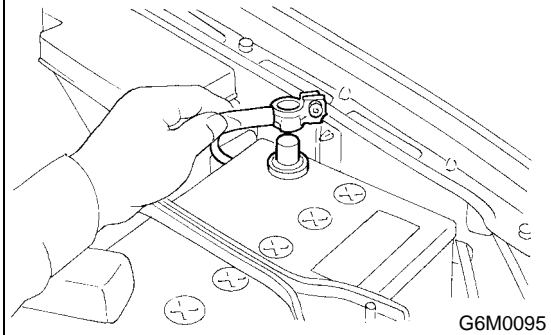

- 4) Remove air intake duct and air cleaner case. (Non-Turbo model)  
<Ref. to IN(SOHC)-7, REMOVAL, Air Intake Duct.> and <Ref. to IN(SOHC)-6, REMOVAL, Air Cleaner Case.>
- 5) Disconnect connector from mass air flow sensor. (Turbo model)

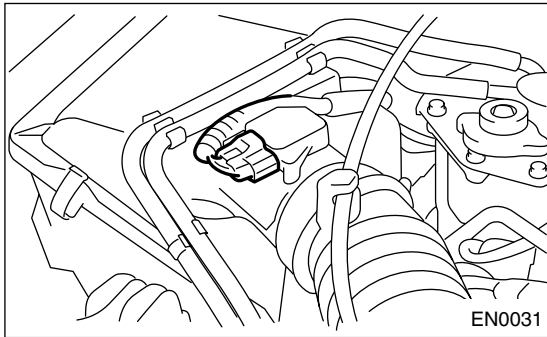

- 6) Remove air intake boot and air cleaner upper cover. (Turbo model)

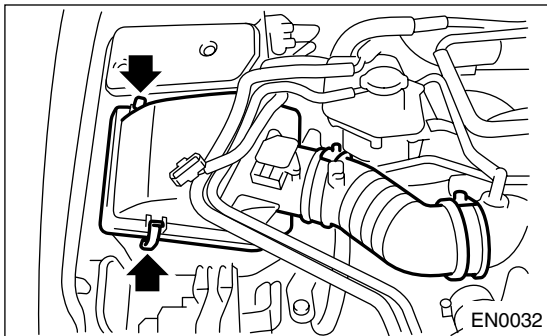

- 7) Remove intercooler (Turbo model) <Ref. to IN(DOHC TURBO)-10, REMOVAL, Intercooler.>

- 8) Remove pitching stopper.

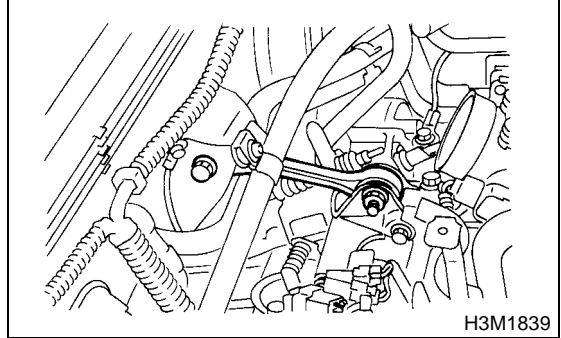

- 9) Remove radiator upper brackets.
  - Non-Turbo model

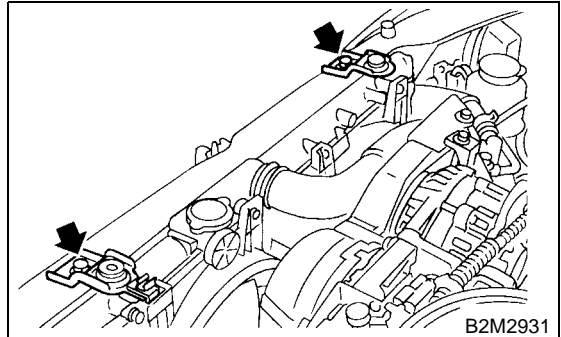

- Turbo model

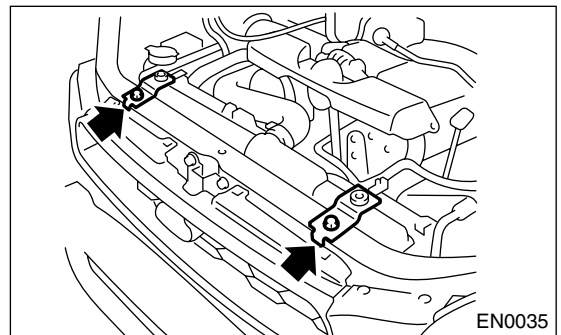

- 10) Support engine with a lifting device and wire ropes.

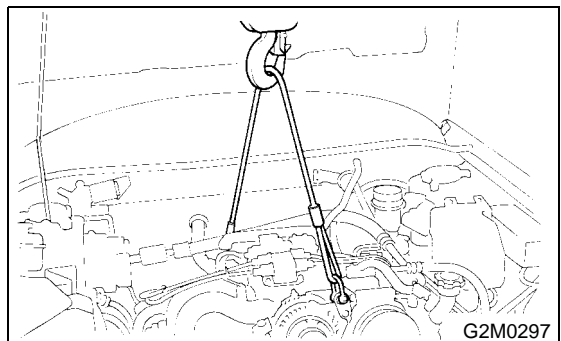

- 11) Lift-up the vehicle.

### CAUTION:

At this time, raise up wire ropes.

- 12) Remove under cover.

13) Drain engine oil.

Set container under the vehicle, and remove drain plug from oil pan.

- Non-Turbo model

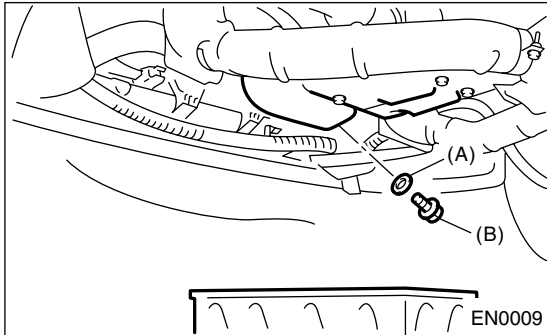

- Turbo model

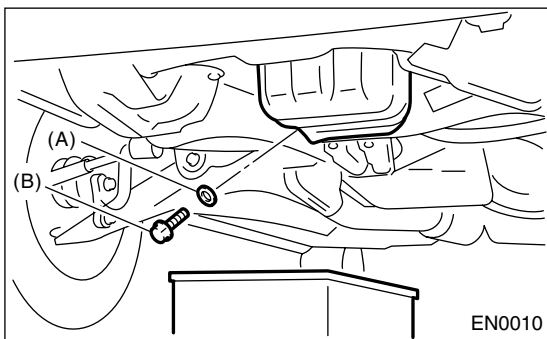

- (A) Gasket
- (B) Drain plug

14) Remove front and center exhaust pipes. (Non-Turbo model) <Ref. to EX(SOHC)-7, REMOVAL, Front Exhaust Pipe.> or <Ref. to EX(SOHCw/oOBD)-9, REMOVAL, Front Exhaust Pipe.>

15) Remove nuts which install front cushion rubber onto front crossmember.

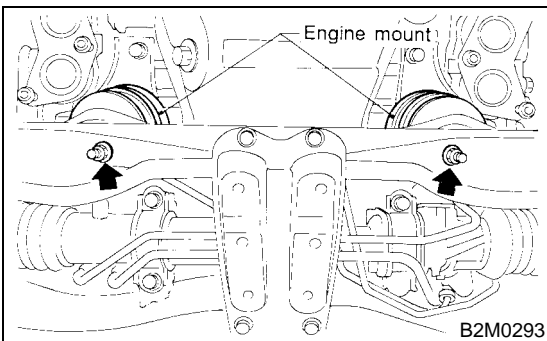

16) Remove bolts which install oil pan on cylinder block while raising up engine.

17) Insert oil pan cutter blade between cylinder block-to-oil pan clearance.

**CAUTION:**

Do not use a screwdriver or similar tool in place of oil pan cutter.

- Non-Turbo model

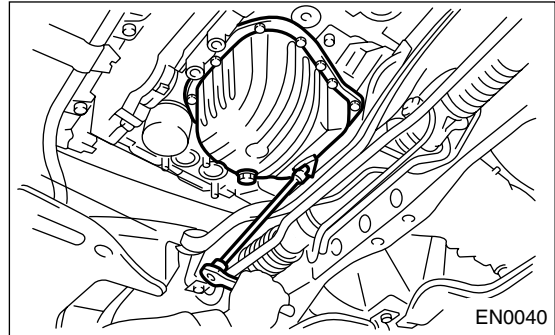

- Turbo model

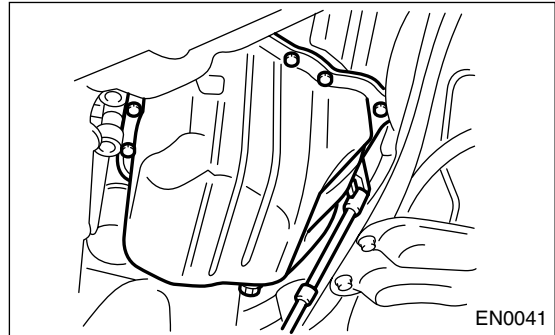

18) Remove oil strainer.

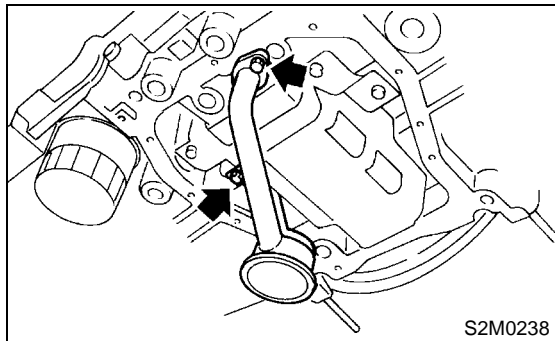

19) Remove baffle plate.

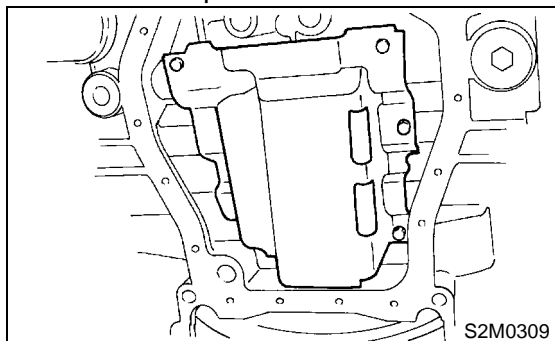

# OIL PAN AND STRAINER

## LUBRICATION

### B: INSTALLATION

#### CAUTION:

Before installing oil pan, clean sealant from oil pan and engine block.

1) Install baffle plate.

#### Tightening torque:

**6.4 N·m (0.65 kgf·m, 4.7 ft·lb)**

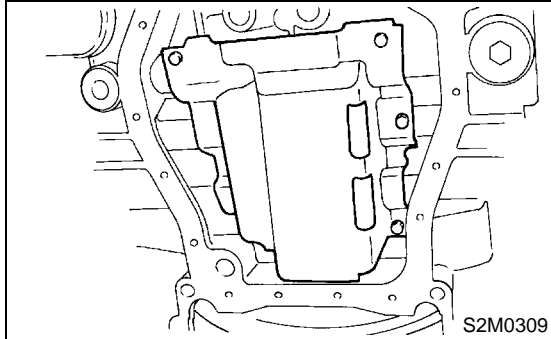

2) Install oil strainer onto baffle plate.

#### CAUTION:

Replace O-ring with a new one.

#### Tightening torque:

**10 N·m (1.0 kgf·m, 7 ft·lb)**

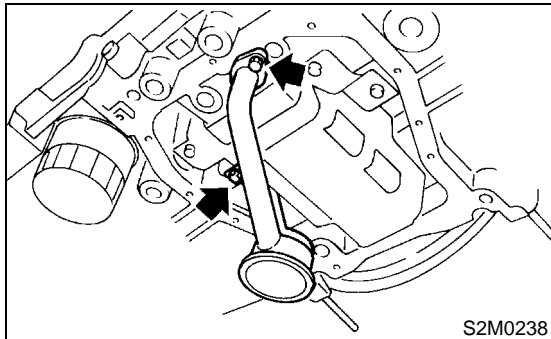

3) Apply fluid packing to mating surfaces and install oil pan.

#### Fluid packing:

**THREE BOND 1215 or equivalent**

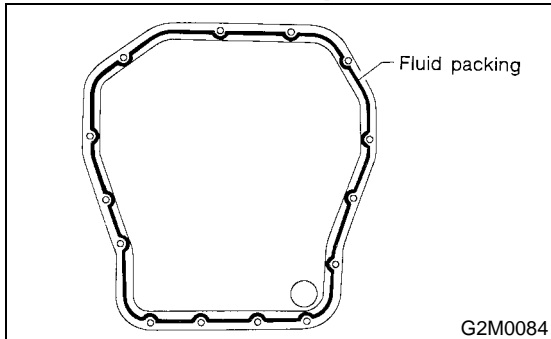

4) Tighten bolts which install oil pan onto engine block.

#### Tightening torque:

**5 N·m (0.5 kgf·m, 3.6 ft·lb)**

- Non-Turbo model

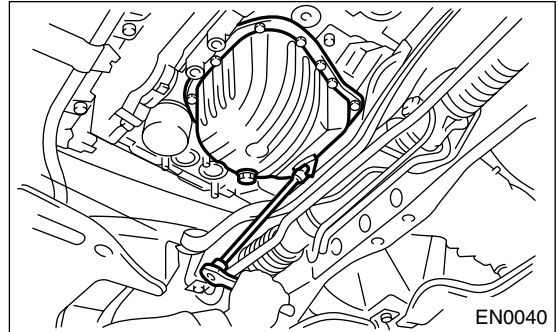

- Turbo model

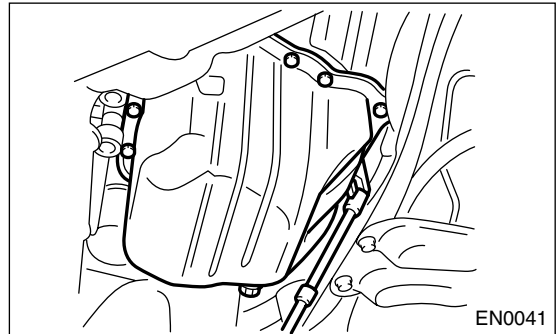

5) Lower engine onto front crossmember.

6) Tighten nuts which install front cushion rubber onto front crossmember.

#### Tightening torque:

**69 N·m (7.0 kgf·m, 51 ft·lb)**

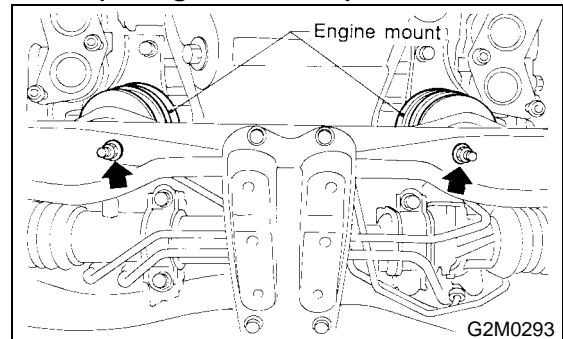

7) Install front and center exhaust pipes. (Non-Turbo model)

<Ref. to EX(SOHC)-8, INSTALLATION, Front Exhaust Pipe.> or <Ref. to EX(SOHCw/oOBD)-10, INSTALLATION, Front Exhaust Pipe.>

**CAUTION:**

Always use the new gaskets.

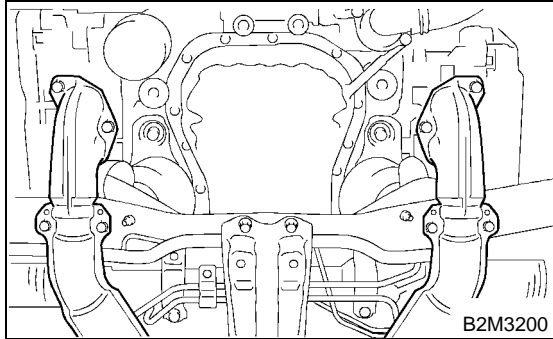

8) Install under cover.

9) Lower the vehicle.

**CAUTION:**

At this time, lower lifting device and release steel cables.

10) Remove lifting device and steel cables.

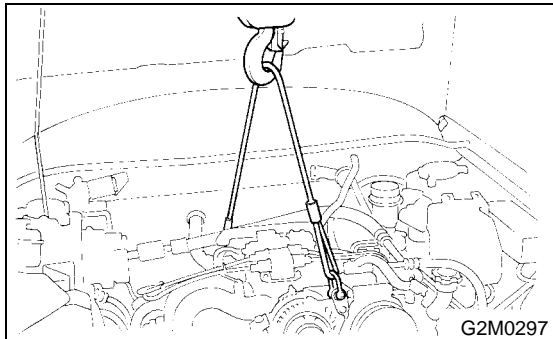

11) Install pitching stopper.

**Tightening torque:**

T1: 50 N·m (5.1 kgf-m, 37 ft-lb)

T2: 58 N·m (5.9 kgf-m, 43 ft-lb)

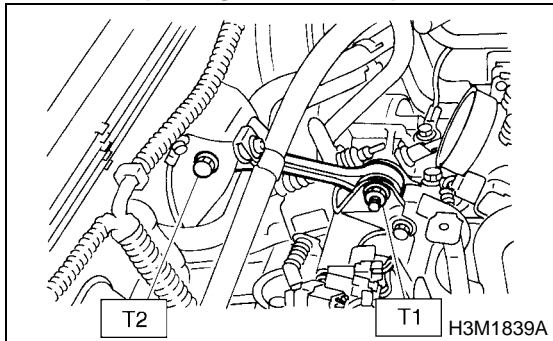

12) Install radiator upper brackets.

- Non-Turbo model

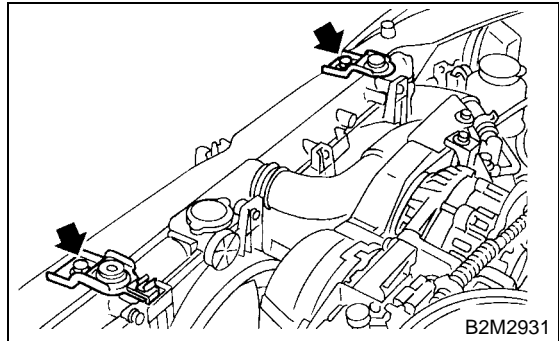

- Turbo model

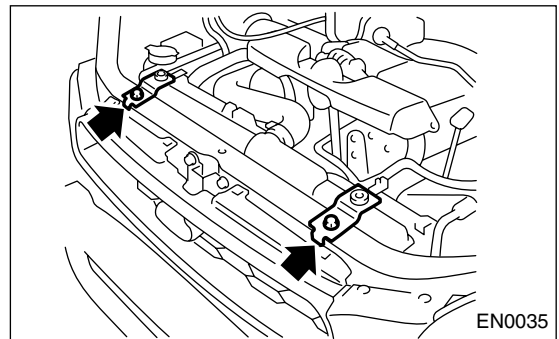

13) Install air intake duct and air cleaner case. (Non-Turbo model)

<Ref. to IN(SOHC)-6, INSTALLATION, Air Cleaner Case.> and <Ref. to IN(SOHC)-7, INSTALLATION, Air Intake Duct.>

14) Install intercooler. (Turbo model) <Ref. to IN(DOHC TURBO)-11, INSTALLATION, Intercooler.>

15) Install air intake boot and air cleaner upper cover. (Turbo model)

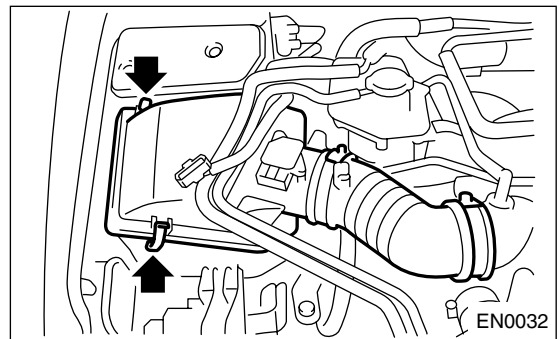

## OIL PAN AND STRAINER

### LUBRICATION

---

- 16) Connect connector to mass air flow sensor.  
(Turbo model)

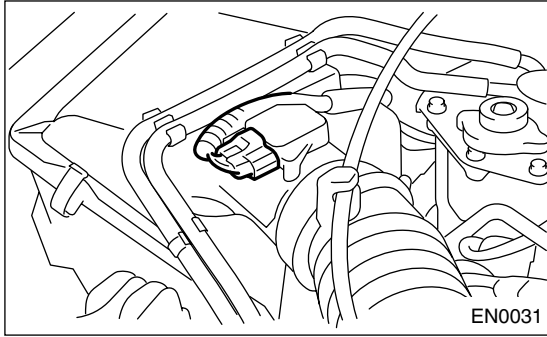

- 17) Install front wheels.  
18) Connect battery ground cable.

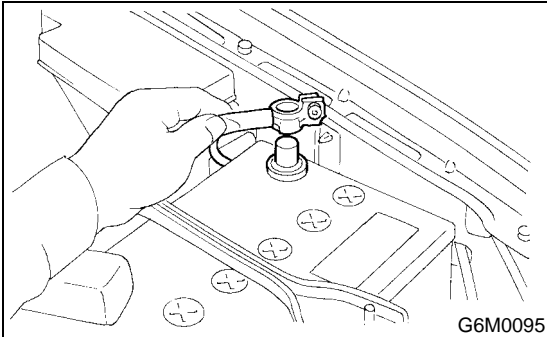

- 19) Fill engine oil. <Ref. to LU-10, INSPECTION, Engine Oil.>

### **C: INSPECTION**

By visual check make sure oil pan, oil strainer, oil strainer stay and baffle plate are not damaged.

## 6. Oil Pressure Switch

### A: REMOVAL

- 1) Remove generator from bracket.
  - (1) Disconnect connector and terminal from generator.

- Non-Turbo model

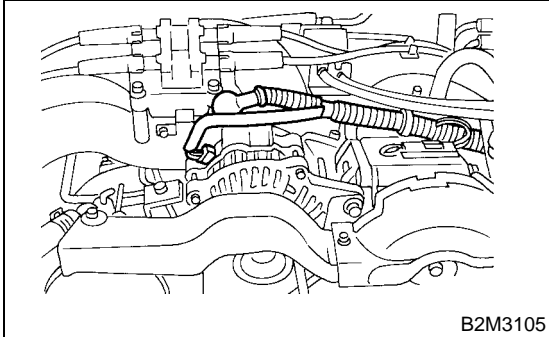

- Turbo model

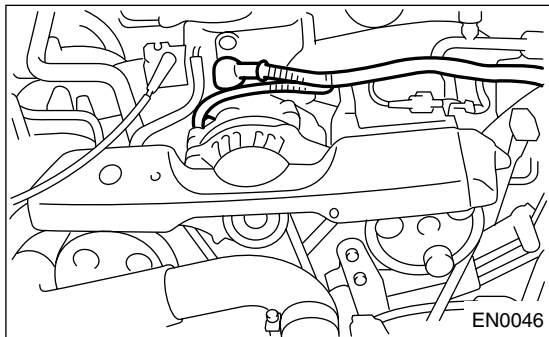

- (2) Remove V-belt cover.

- Non-Turbo model

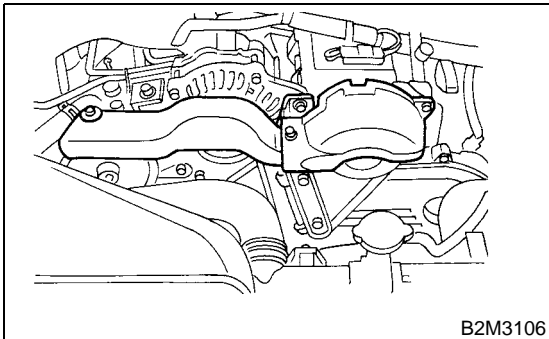

- Turbo model

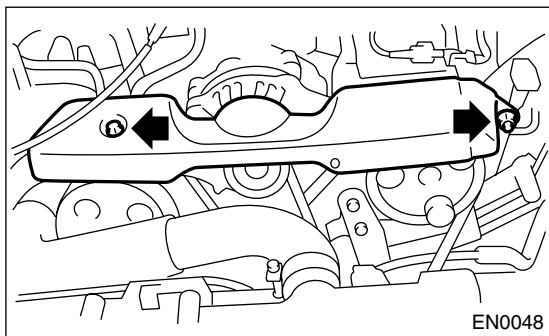

- (3) Remove front side V-belt. <Ref. to ME(SOHC)-42, REMOVAL, V-belt.> or <Ref. to ME(DOHC TURBO)-43, REMOVAL, V-belt.>

- (4) Remove bolts which install generator on bracket.

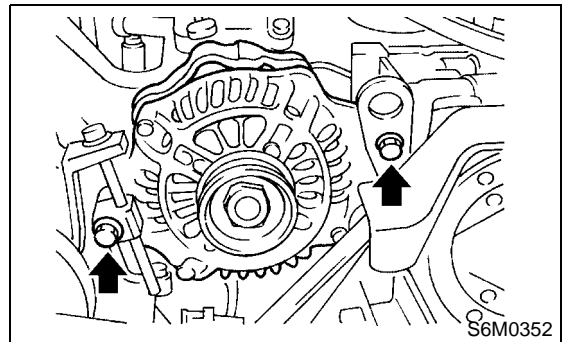

- 2) Disconnect terminal from oil pressure switch.

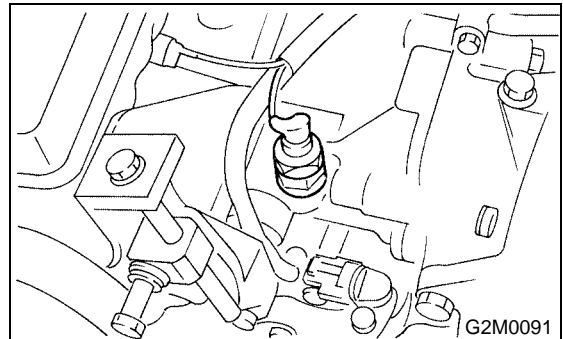

- 3) Remove oil pressure switch.

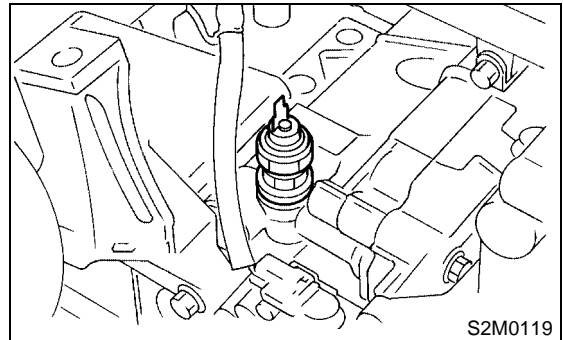

# OIL PRESSURE SWITCH

## LUBRICATION

### B: INSTALLATION

1) Apply fluid packing to oil pressure switch threads.

**Fluid packing:**

**THREE BOND 1215 or equivalent**

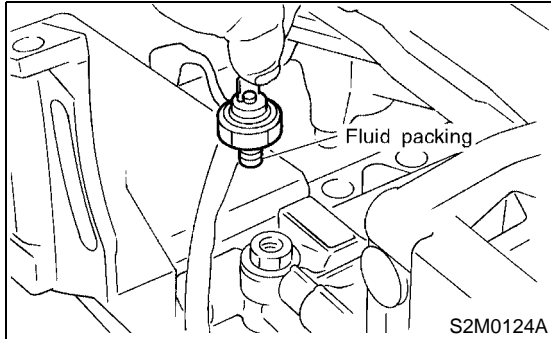

2) Install oil pressure switch onto engine block.

**Tightening torque:**

**25 N·m (2.5 kgf-m, 18.1 ft-lb)**

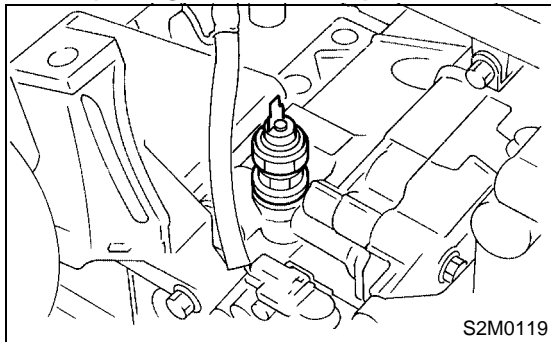

3) Connect terminal of oil pressure switch.

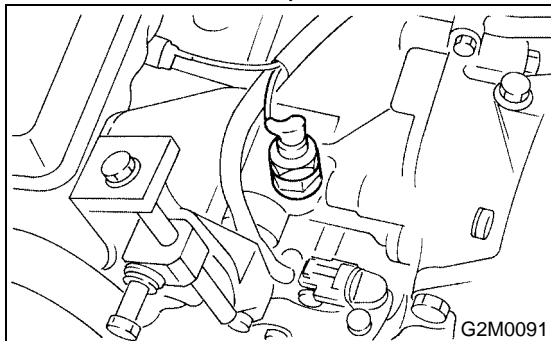

4) Install generator on bracket and temporarily tighten installing bolts.

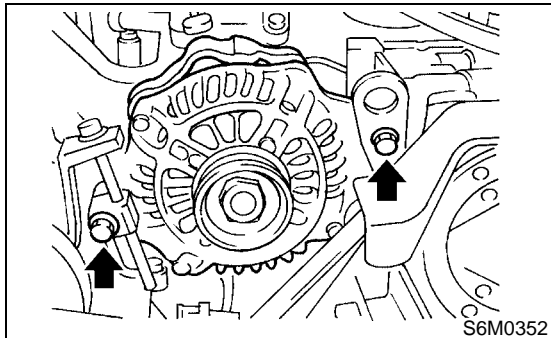

5) Install front side V-belt and adjust it.  
<Ref. to ME(SOHC)-42, INSTALLATION, V-belt.>  
or <Ref. to ME(DOHC TURBO)-43, INSTALLATION, V-belt.>

6) Install V-belt cover.

- Non-Turbo model

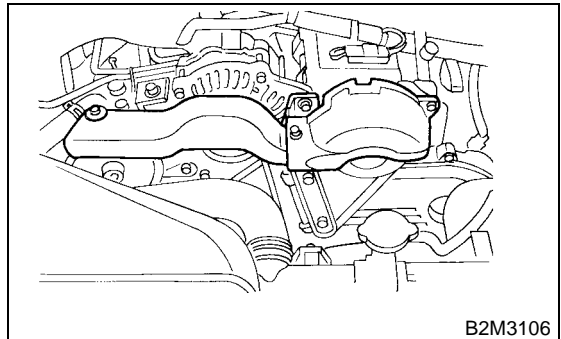

- Turbo model

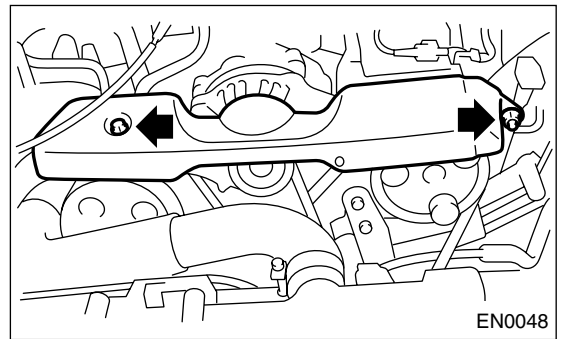

7) Connect connector and terminal to generator.

- Non-Turbo model

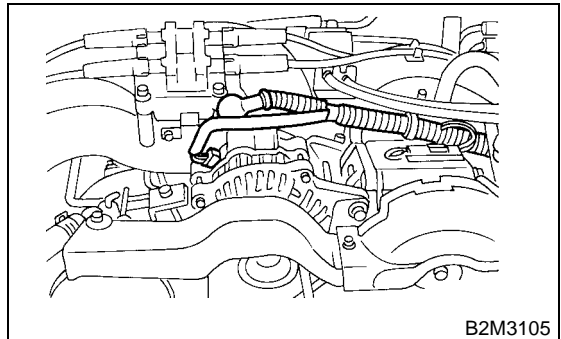

- Turbo model

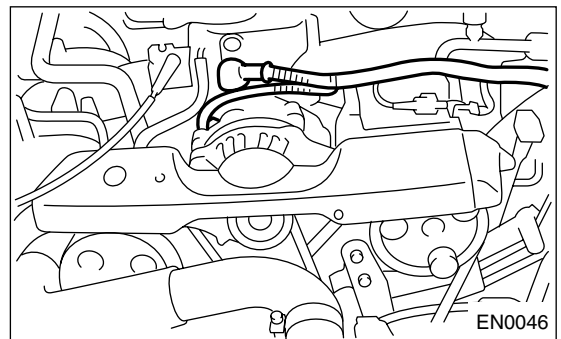

### C: INSPECTION

Make sure oil does not leak or seep from where the oil pressure switch is installed.

## 7. Engine Oil Cooler

### A: REMOVAL

- 1) Lift-up the vehicle.
- 2) Remove under cover.
- 3) Drain engine oil.

Set container under the vehicle, and remove drain plug from oil pan.

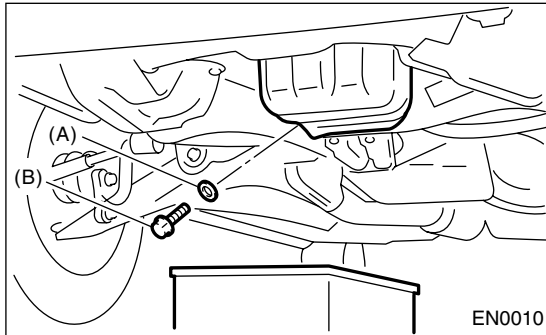

- (A) Metal gasket
- (B) Drain plug

- 4) Drain coolant.
- 5) Remove water by-pass pipe between oil cooler and water pump.

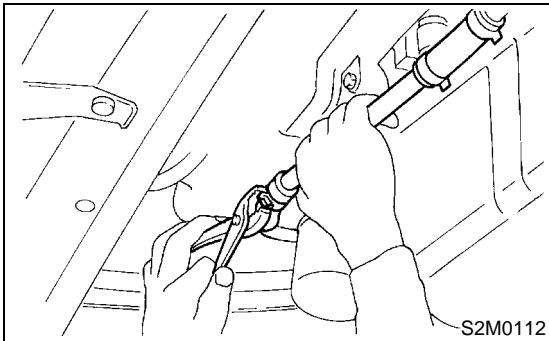

- 6) Remove engine oil filter. <Ref. to LU-25, REMOVAL, Engine Oil Filter.>

- 7) Remove connector and remove oil cooler.

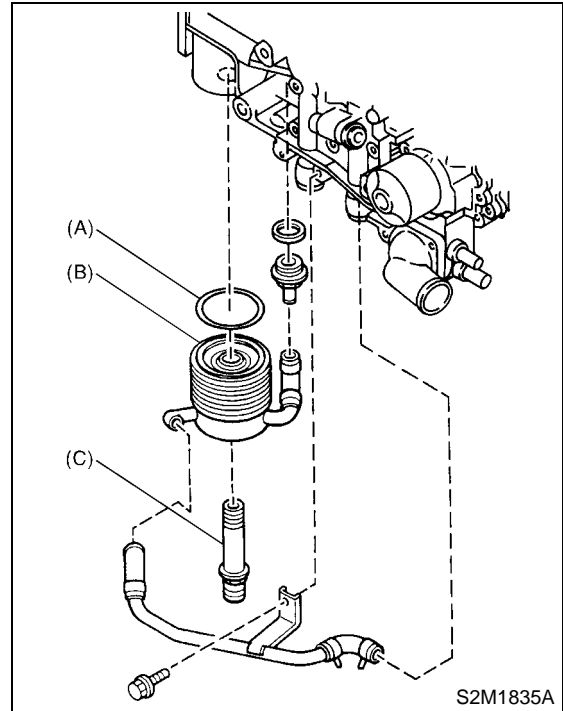

- (A) O-ring
- (B) Oil cooler
- (C) Connector



# ENGINE OIL COOLER

## LUBRICATION

### B: INSTALLATION

1) Install in the reverse order of removal.

**Tightening torque:**

***T: 54 N·m (5.5 kgf-m, 39.8 ft-lb)***

**CAUTION:**

**Always use a new O-ring.**

### C: INSPECTION

1) Check that coolant passages are not clogged using air blow method.

2) Check mating surfaces of cylinder block, O-ring groove and oil filter for damage.

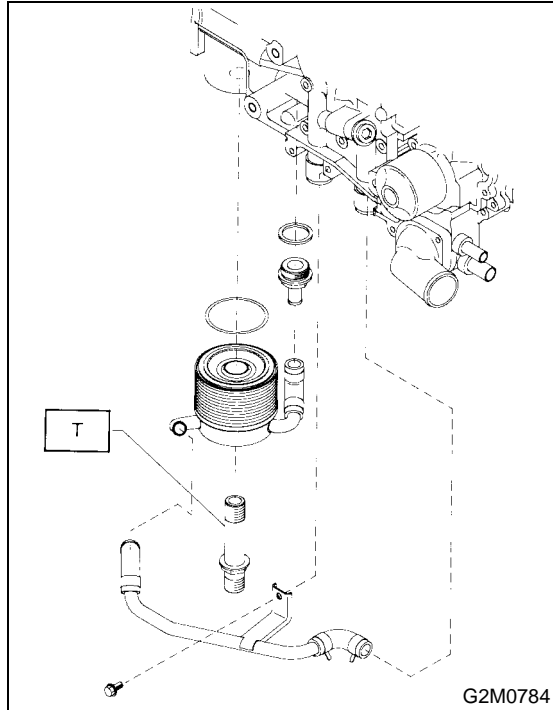

## 8. Engine Oil Filter

### A: REMOVAL

- 1) Remove under cover.
- 2) Remove oil filter with ST.

ST 498547000 OIL FILTER WRENCH

- Non-Turbo model

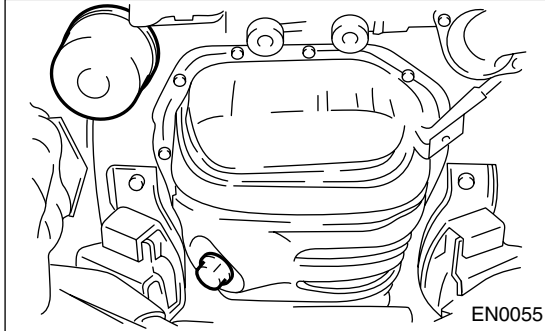

- Turbo model

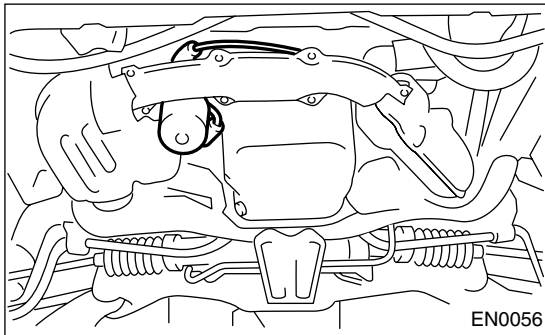

### B: INSTALLATION

- 1) Get a new oil filter and apply a thin coat of engine oil to the seal rubber.
- 2) Install oil filter by turning it by hand, being careful not to damage seal rubber.
- 3) Tighten more (approximately 2/3 to 3/4 turn) after the seal rubber contacts the oil pump case. Do not tighten excessively, or oil may leak.

### C: INSPECTION

- 1) After installing oil filter, run engine and make sure that no oil is leaking around seal rubber.

#### NOTE:

The filter element and filter case are permanently jointed; therefore, interior cleaning is not necessary.

- 2) Check the engine oil level. <Ref. to LU-10, INSPECTION, Engine Oil.>

# ENGINE LUBRICATION SYSTEM TROUBLE IN GENERAL

LUBRICATION

## 9. Engine Lubrication System Trouble in General

### A: INSPECTION

Before performing diagnostics, make sure that the engine oil level is correct and no oil leakage exists.

Trouble	Possible cause	Corrective action	
1. Warning light remains on.	1) Oil pressure switch failure	Cracked diaphragm or oil leakage within switch	Replace.
		Broken spring or seized contacts	Replace.
	2) Low oil pressure	Clogged oil filter	Replace.
		Malfunction of oil by-pass valve of oil filter	Clean or replace.
		Malfunction of oil relief valve of oil pump	Clean or replace.
		Clogged oil passage	Clean.
		Excessive tip clearance and side clearance of oil pump rotor and gear	Replace.
		Clogged oil strainer or broken pipe	Clean or replace.
	3) No oil pressure	Insufficient engine oil	Replenish.
		Broken pipe of oil strainer	Replace.
Stuck oil pump rotor		Replace.	
2. Warning light does not go on.	1) Burn-out bulb	Replace.	
	2) Poor contact of switch contact points	Replace.	
	3) Disconnection of wiring	Repair.	
3. Warning light flickers momentarily.	1) Poor contact at terminals	Repair.	
	2) Defective wiring harness	Repair.	
	3) Low oil pressure	Check for the same possible causes as listed in 1.—2).	