

**ENGINE 2 SECTION**

This service manual has been prepared to provide SUBARU service personnel with the necessary information and data for the correct maintenance and repair of SUBARU vehicles.

This manual includes the procedures for maintenance, disassembling, reassembling, inspection and adjustment of components and diagnostics for guidance of experienced mechanics.

Please peruse and utilize this manual fully to ensure complete repair work for satisfying our customers by keeping their vehicle in optimum condition. When replacement of parts during repair work is needed, be sure to use SUBARU genuine parts.

All information, illustration and specifications contained in this manual are based on the latest product information available at the time of publication approval.

**FUEL INJECTION (FUEL SYSTEMS) FU(SOHCw/oOBD)**

**EMISSION CONTROL (AUX. EMISSION CONTROL DEVICES) EC(SOHCw/oOBD)**

**EXHAUST EX(SOHCw/oOBD)**

**IGNITION IG(SOHCw/oOBD)**

**ENGINE(DIAGNOSTICS) EN(SOHCw/oOBD)**

**FUEL INJECTION (FUEL SYSTEMS) FU(DOHC TURBO)**

**EMISSION CONTROL (AUX. EMISSION CONTROL DEVICES) EC(DOHC TURBO)**

**INTAKE (INDUCTION) IN(DOHC TURBO)**

**MECHANICAL ME(DOHC TURBO)**

**EXHAUST EX(DOHC TURBO)**

**IGNITION IG(DOHC TURBO)**

**ENGINE (DIAGNOSTICS) EN(DOHC TURBO)**

# FUEL INJECTION (FUEL SYSTEMS)

# *FU(SOHCw/oOBD)*

---

|  | <b>Page</b> |
|--|-------------|
| 1. General Description .....                         | 2           |
| 2. Throttle Body .....                               | 14          |
| 3. Intake Manifold .....                             | 15          |
| 4. Engine Coolant Temperature Sensor.....            | 27          |
| 5. Crankshaft Position Sensor.....                   | 28          |
| 6. Camshaft Position Sensor.....                     | 29          |
| 7. Knock Sensor .....                                | 30          |
| 8. Throttle Position Sensor .....                    | 31          |
| 9. Intake Air Temperature and Pressure Sensor.....   | 34          |
| 10. Idle Air Control Solenoid Valve .....            | 35          |
| 11. Fuel Injector .....                              | 36          |
| 12. Oxygen Sensor .....                              | 42          |
| 13. Engine Control Module.....                       | 44          |
| 14. Main Relay .....                                 | 45          |
| 15. Fuel Pump Relay.....                             | 46          |
| 16. Fuel .....                                       | 47          |
| 17. Fuel Tank .....                                  | 48          |
| 18. Fuel Filler Pipe .....                           | 50          |
| 19. Fuel Pump.....                                   | 54          |
| 20. Fuel Level Sensor .....                          | 56          |
| 21. Fuel Filter .....                                | 57          |
| 22. Fuel Cut Valve.....                              | 58          |
| 23. Fuel Damper Valve .....                          | 59          |
| 24. Fuel Delivery, Return and Evaporation Lines..... | 60          |
| 25. Fuel System Trouble in General .....             | 63          |

## GENERAL DESCRIPTION

FUEL INJECTION (FUEL SYSTEMS)

---

### 1. General Description

#### A: SPECIFICATIONS

|             |                            |  |
|-------------|----------------------------|--|
| Model       |                            |  |
| Fuel tank   | Capacity                   | 50 ℓ (13.2 US gal, 11.0 Imp gal)   |
|             | Location                   | Under rear seat  |
| Fuel pump   | Type                       | Impeller   |
|             | Shutoff discharge pressure | 370 — 677 kPa (3.77 — 6.9 kg/cm <sup>2</sup> , 53.6 — 98 psi)  |
|             | Discharge flow             | More than 65 ℓ (17.2 US gal, 14.3 Imp gal)/h<br>[12 V at 300 kPa (3.06 kg/cm <sup>2</sup> , 43.5 psi)] |
| Fuel filter |                            | Cartridge type   |

# GENERAL DESCRIPTION

FUEL INJECTION (FUEL SYSTEMS)

---

# GENERAL DESCRIPTION

FUEL INJECTION (FUEL SYSTEMS)

## B: COMPONENT

### 1. INTAKE MANIFOLD

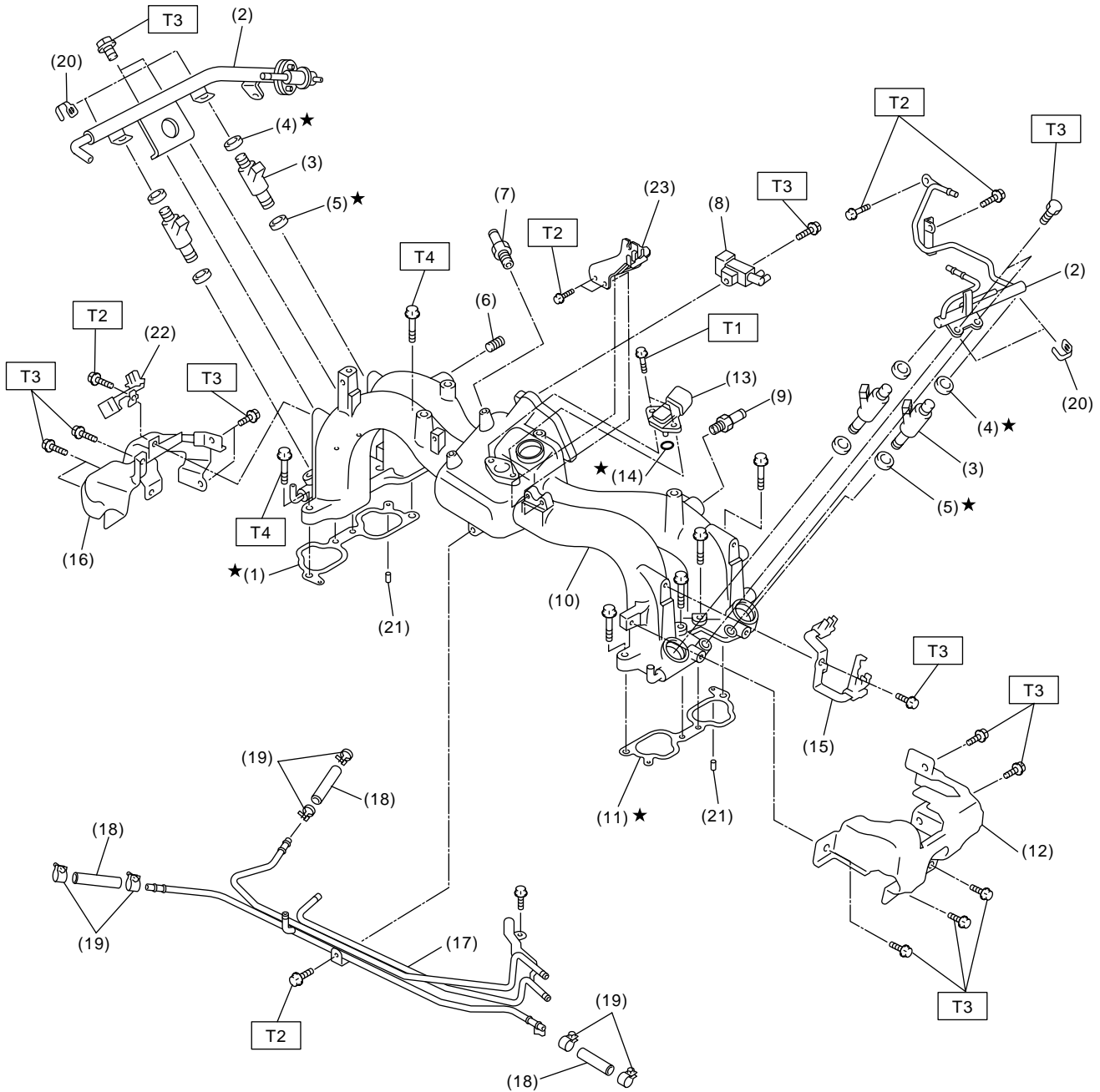

EN1002

FU(SOHCw/oOBD)-4

# GENERAL DESCRIPTION

## FUEL INJECTION (FUEL SYSTEMS)

---

- |                                  |   |                                |
|----------------------------------|---|--------------------------------|
| (1) Intake manifold gasket RH    | (11) Intake manifold gasket LH                  | (20) Clip                      |
| (2) Fuel injector pipe           | (12) Fuel pipe protector LH                     | (21) Guide pin                 |
| (3) Fuel injector                | (13) Intake air temperature and pressure sensor | (22) Plug cord holder RH       |
| (4) O-ring                       |   | (23) Accelerator cable bracket |
| (5) O-ring                       | (14) O-ring                                     |                                |
| (6) Plug                         | (15) Plug cord holder LH                        |                                |
| (7) PCV valve                    | (16) Fuel pipe protector RH                     |                                |
| (8) Purge control solenoid valve | (17) Fuel pipe ASSY                             |                                |
| (9) Nipple                       | (18) Fuel hose                                  |                                |
| (10) Intake manifold             | (19) Clip                                       |                                |

---

**Tightening torque: N·m (kgf-m, ft-lb)****T1: 3.4 (0.35, 2.5)****T2: 5.0 (0.51, 3.7)****T3: 19 (0.19, 1.4)****T4: 25 (2.6, 18.8)**

---

# GENERAL DESCRIPTION

FUEL INJECTION (FUEL SYSTEMS)

## 2. AIR INTAKE SYSTEM

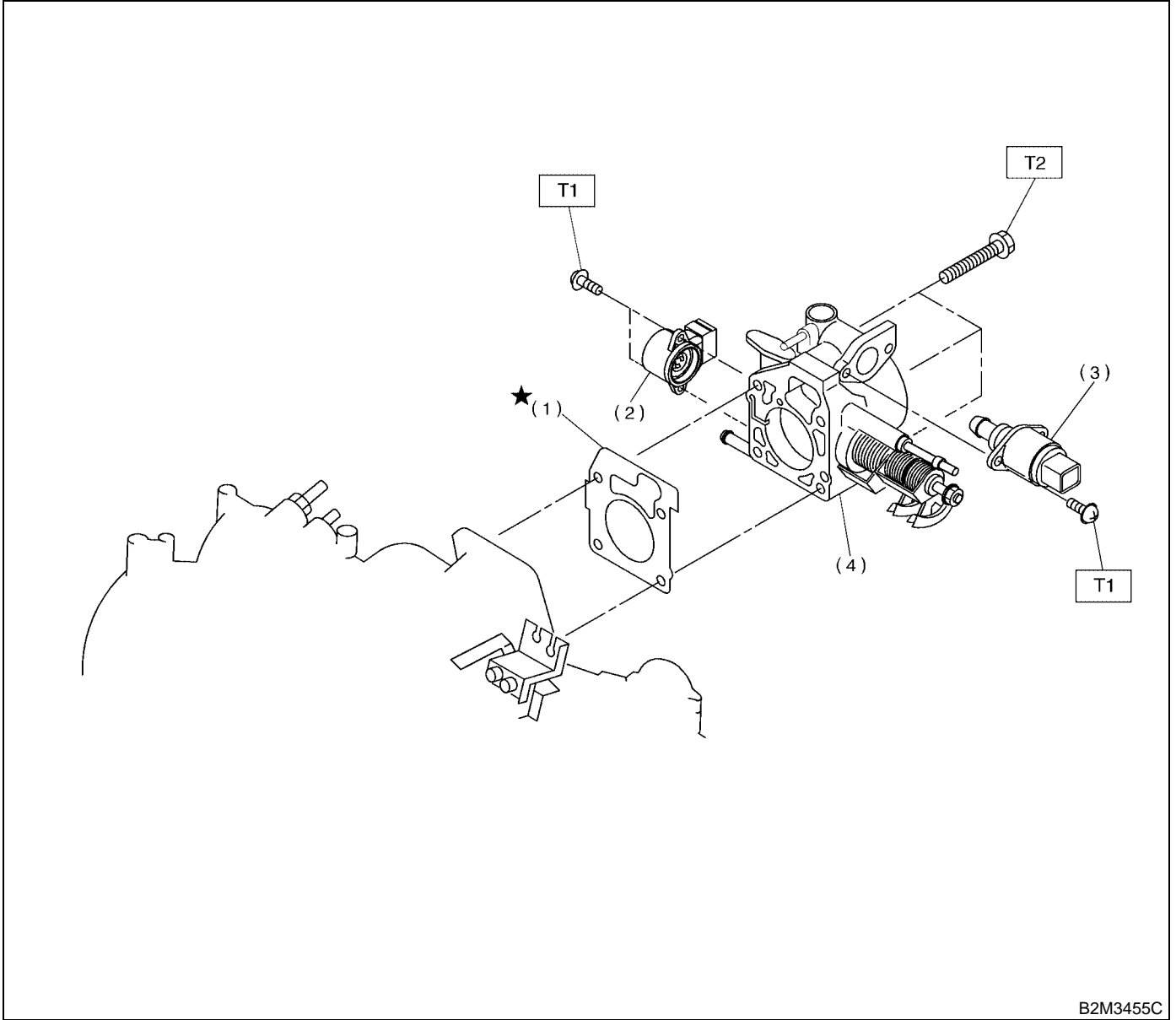

B2M3455C

- (1) Gasket
- (2) Throttle position sensor
- (3) Idle air control solenoid valve

- (4) Throttle body

**Tightening torque: N·m (kgf-m, ft-lb)**

**T1: 1.6 (0.16, 1.2)**

**T2: 22 (2.2, 16)**

# GENERAL DESCRIPTION

FUEL INJECTION (FUEL SYSTEMS)

## 3. CRANKSHAFT POSITION, CAMSHAFT POSITION AND KNOCK SENSORS

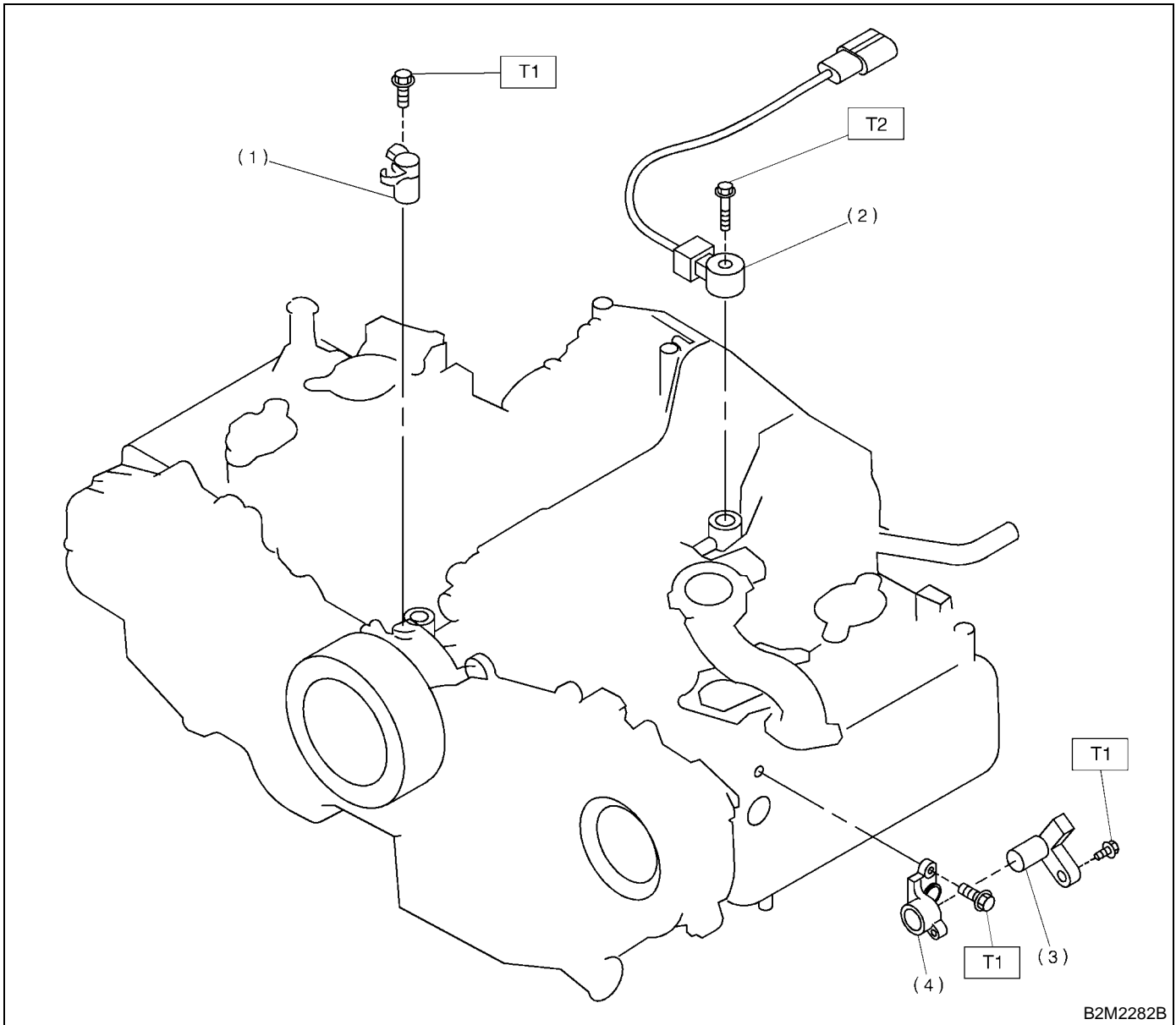

B2M2282B

- (1) Crankangle position sensor
- (2) Knock sensor

- (3) Camshaft position sensor
- (4) Camshaft position sensor support

**Tightening torque: N·m (kgf-m, ft-lb)**

**T1: 6.4 (0.65, 4.7)**

**T2: 24 (2.4, 17.4)**



# GENERAL DESCRIPTION

## FUEL INJECTION (FUEL SYSTEMS)

### 4. FUEL TANK

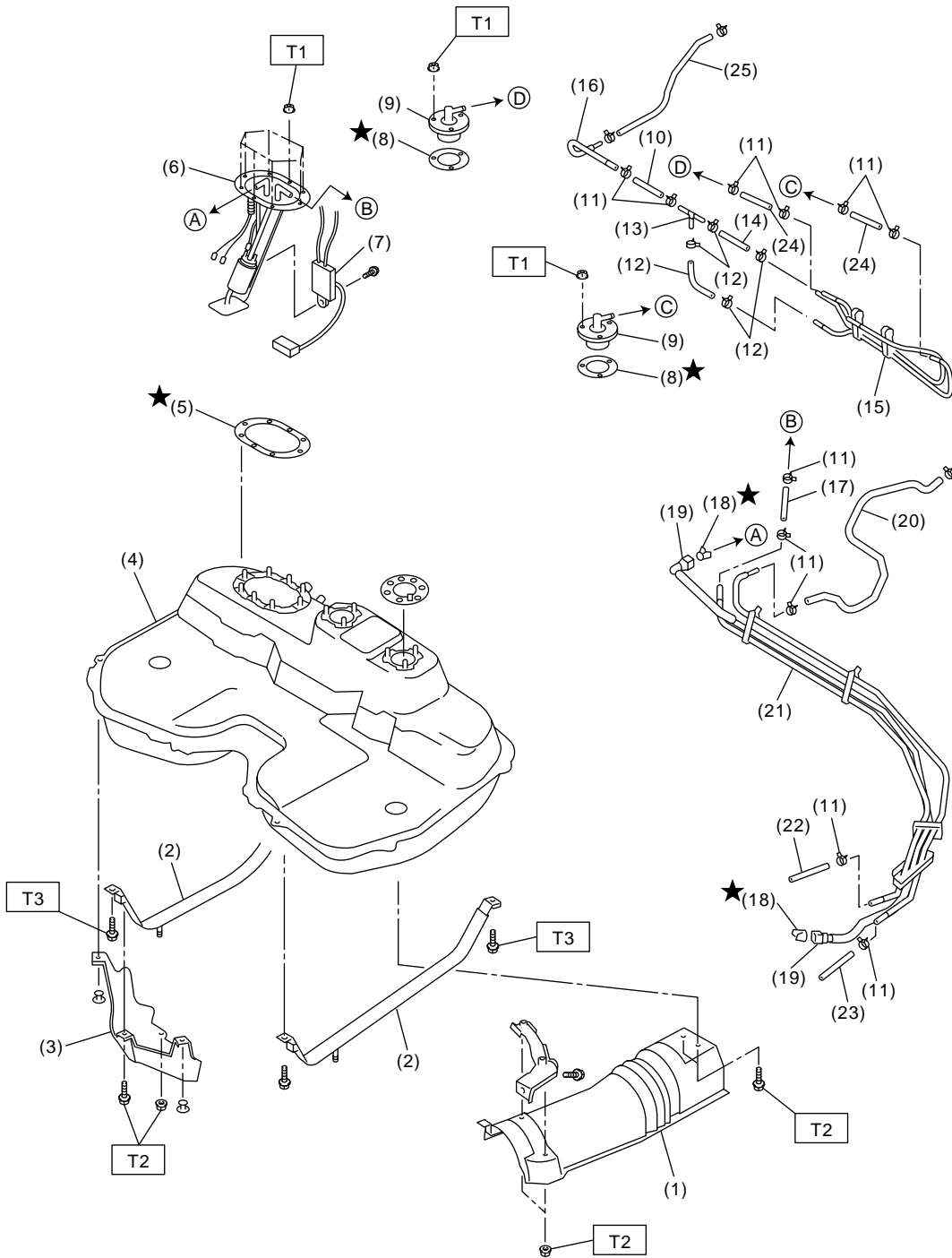

EN0439

# GENERAL DESCRIPTION

## FUEL INJECTION (FUEL SYSTEMS)

---

|                           |                            |                         |
|---------------------------|----------------------------|-------------------------|
| (1) Heat sealed cover     | (11) Clip                  | (21) Fuel pipe ASSY     |
| (2) Fuel tank band        | (12) Evaporation hose B    | (22) Evaporation hose F |
| (3) Protector RH          | (13) Joint pipe            | (23) Fuel return hose B |
| (4) Fuel tank             | (14) Evaporation hose C    | (24) Evaporation hose G |
| (5) Fuel pump gasket      | (15) Evaporation pipe ASSY | (25) Evaporation hose H |
| (6) Fuel pump ASSY        | (16) Evaporation pipe      |                         |
| (7) Fuel meter unit       | (17) Evaporation hose D    |                         |
| (8) Fuel cut valve gasket | (18) Retainer              |                         |
| (9) Fuel cut valve        | (19) Quick connector       |                         |
| (10) Evaporation hose A   | (20) Evaporation hose E    |                         |

---

***Tightening torque: N·m (kgf·m, ft·lb)***

***T1: 4.4 (0.45, 3.3)***

***T2: 7.4 (0.75, 5.4)***

***T3: 33 (3.4, 25)***

---

# GENERAL DESCRIPTION

## FUEL INJECTION (FUEL SYSTEMS)

### 5. FUEL LINE

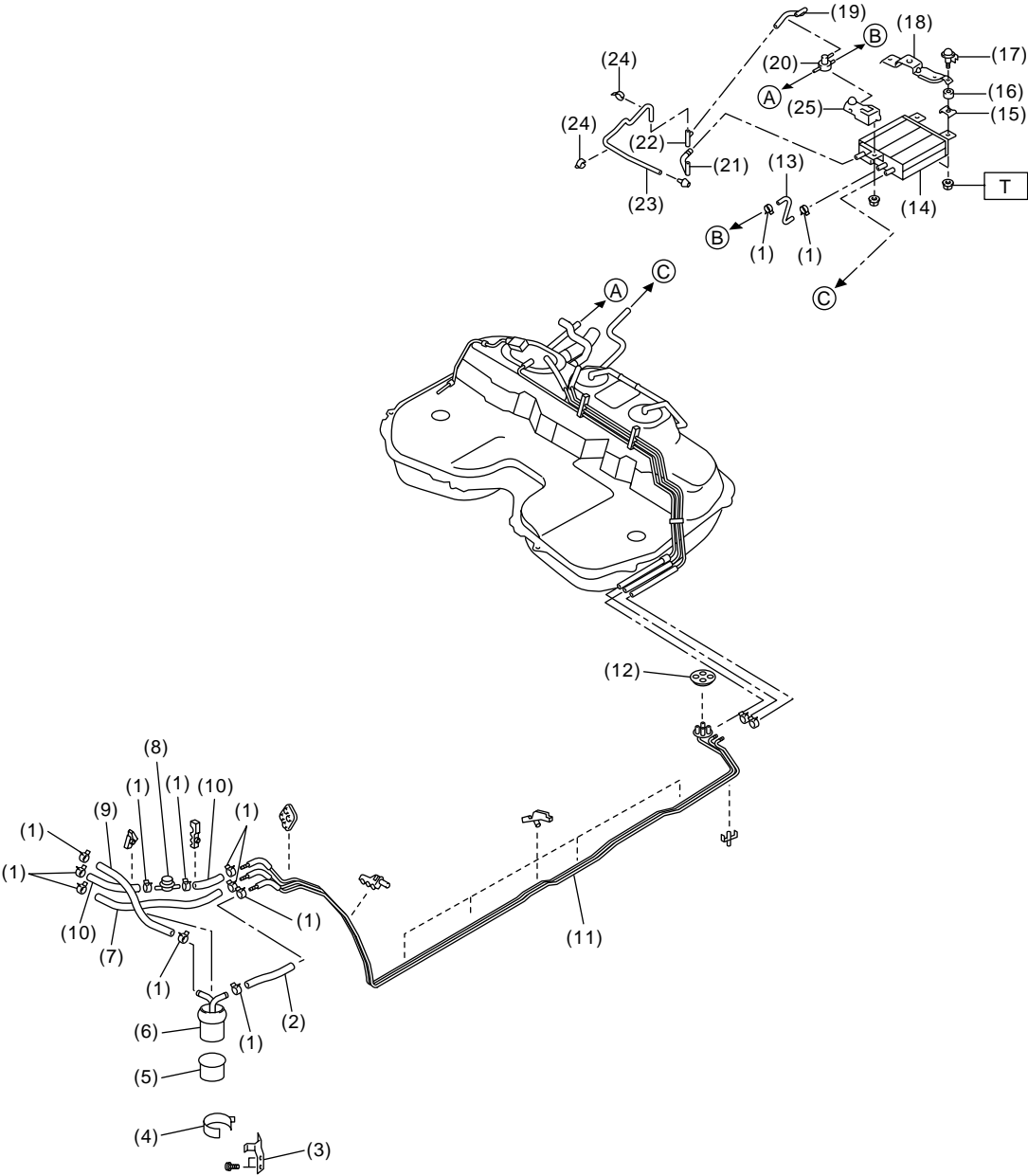

EN0440

# GENERAL DESCRIPTION

## FUEL INJECTION (FUEL SYSTEMS)

- |                          |                                |                                 |
|--------------------------|--------------------------------|---------------------------------|
| (1) Clip                 | (11) Fuel pipe ASSY            | (21) Two-way valve drain hose A |
| (2) Fuel delivery hose A | (12) Grommet                   | (22) Connector                  |
| (3) Fuel filter bracket  | (13) Canister hose A           | (23) Two-way valve drain hose B |
| (4) Fuel filter holder   | (14) Canister                  | (24) Clamp                      |
| (5) Fuel filter cup      | (15) Canister bracket plate    | (25) Front canister bracket     |
| (6) Fuel filter          | (16) Cushion                   |                                 |
| (7) Evaporation hose     | (17) Canister bracket spacer   |                                 |
| (8) Fuel damper          | (18) Rear canister bracket     |                                 |
| (9) Fuel delivery hose B | (19) Two-way valve return hose |                                 |
| (10) Fuel return hose    | (20) Two-way valve             |                                 |

---

***Tightening torque: N·m (kgf·m, ft·lb)***

***T: 23 (2.34, 17.0)***

---

# GENERAL DESCRIPTION

FUEL INJECTION (FUEL SYSTEMS)

## 6. FUEL FILLER PIPE

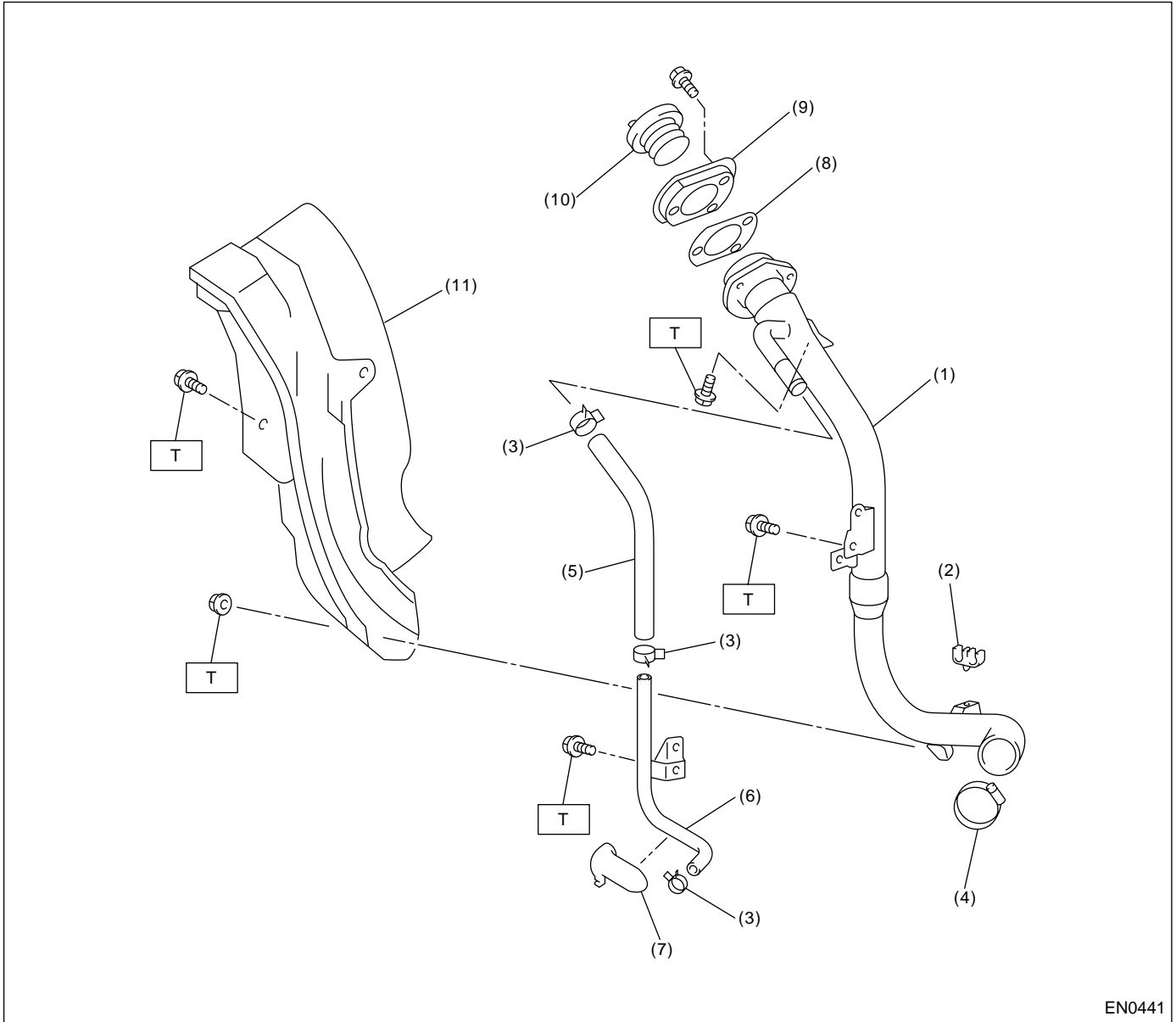

- |   |  |
|---|--|
| <ul style="list-style-type: none"> <li>(1) Fuel filter pipe ASSY</li> <li>(2) Evaporation hose holder</li> <li>(3) Clamp</li> <li>(4) Clamp</li> <li>(5) Air vent hose</li> </ul> | <ul style="list-style-type: none"> <li>(6) Air vent pipe</li> <li>(7) Air vent pipe holder</li> <li>(8) Filler pipe packing</li> <li>(9) Filler ring</li> <li>(10) Filler cap</li> </ul> |
|---|--|

---

**Tightening torque: N·m (kgf-m, ft-lb)**  
**T: 7.5 (0.76, 5.5)**

---

# GENERAL DESCRIPTION



FUEL INJECTION (FUEL SYSTEMS)

## C: CAUTION

- Wear working clothing, including a cap, protective goggles, and protective shoes during operation.
- Remove contamination including dirt and corrosion before removal, installation or disassembly.
- Keep the disassembled parts in order and protect them from dust or dirt.
- Before removal, installation or disassembly, be sure to clarify the failure. Avoid unnecessary removal, installation, disassembly, and replacement.

- Be careful not to burn your hands, because each part on the vehicle is hot after running.
- Be sure to tighten fasteners including bolts and nuts to the specified torque.
- Place shop jacks or safety stands at the specified points.
- Before disconnecting electrical connectors of sensors or units, be sure to disconnect negative terminal from battery.
- Place "NO FIRE" signs near the working area.
- Be careful not to spill fuel on the floor.

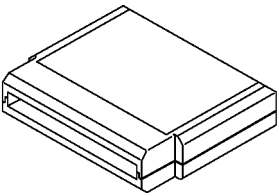
## D: PREPARATION TOOL

| ILLUSTRATION   | TOOL NUMBER                        | DESCRIPTION        | REMARKS  |
|--|------------------------------------|--------------------|--|
|  <p>B2M3876</p>   | 24082AA150<br>(Newly adopted tool) | CARTRIDGE          | Troubleshooting for electrical system.   |
|  <p>B2M3877</p> | 22771AA030                         | SELECT MONITOR KIT | Troubleshooting for electrical systems. <ul style="list-style-type: none"> <li>• English: 22771AA030 (Without printer)</li> <li>• German: 22771AA070 (Without printer)</li> <li>• French: 22771AA080 (Without printer)</li> <li>• Spanish: 22771AA090 (Without printer)</li> </ul> |

# THROTTLE BODY

## FUEL INJECTION (FUEL SYSTEMS)

### 2. Throttle Body

#### A: REMOVAL

1) Disconnect battery ground cable.

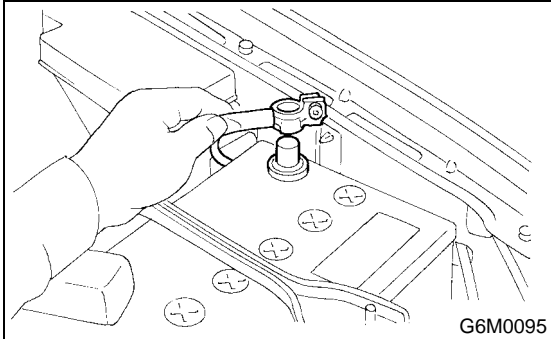

2) Remove air cleaner case.

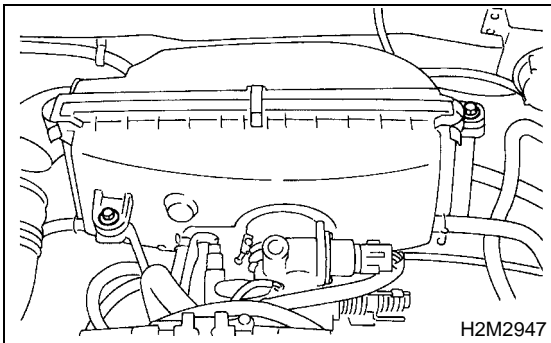

3) Disconnect accelerator cable (A).

4) Disconnect cruise control cable (B). (With cruise control model)

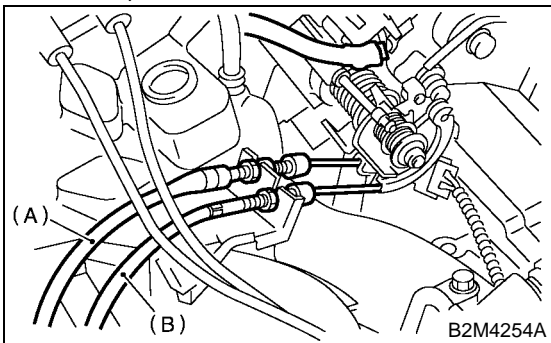

5) Disconnect connectors from idle air control solenoid valve, throttle position sensor.

6) Disconnect air by-pass hose from air purge control solenoid valve.

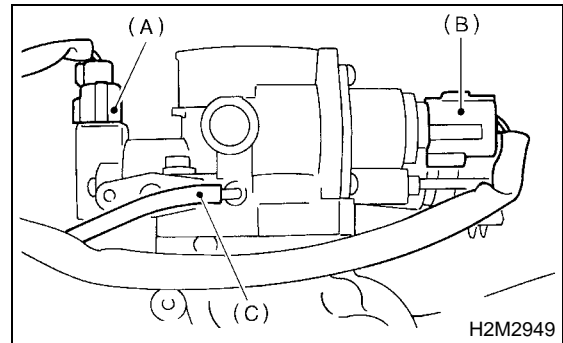

(A) Throttle position sensor

(B) Idle air control solenoid valve

(C) Air by-pass hose from purge control solenoid valve

7) Disconnect engine coolant hoses from throttle body.

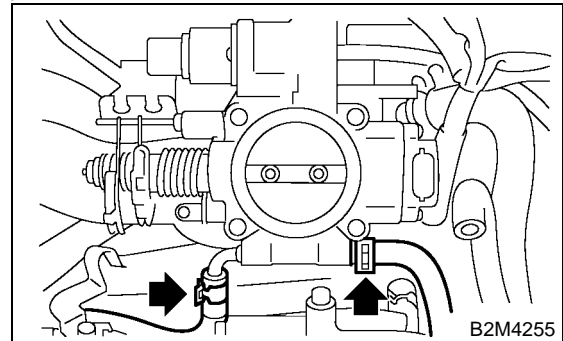

8) Remove bolts which install throttle body to intake manifold.

#### B: INSTALLATION

Install in the reverse order of removal.

#### CAUTION:

Always use a new gasket.

#### Tightening torque:

*Throttle body;*

*22 N·m (2.2 kgf-m, 15.9 ft-lb)*

*Air cleaner case;*

*6.5 N·m (0.66 kgf-m, 4.8 ft-lb)*

## 3. Intake Manifold

### A: REMOVAL

- 1) Release fuel pressure. <Ref. to FU(SOHCw/oOBD)-47, RELEASING OF FUEL PRESSURE, OPERATION, Fuel.>
- 2) Open fuel flap lid, and remove fuel filler cap.
- 3) Disconnect battery ground cable.

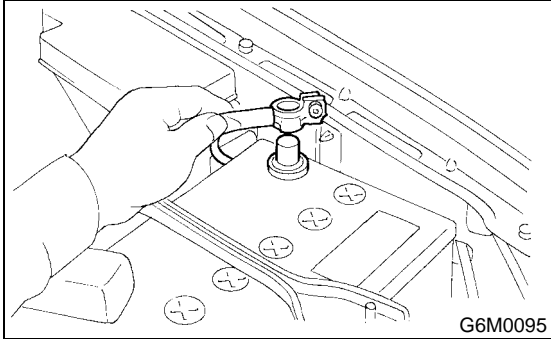

- 4) Remove air intake duct and air cleaner assembly. <Ref. to IN(SOHC)-7, REMOVAL, Air Intake Duct.> and <Ref. to IN(SOHC)-6, REMOVAL, Air Cleaner Case.>
- 5) Disconnect accelerator cable (A).
- 6) Disconnect cruise control cable (B). (With cruise control model)

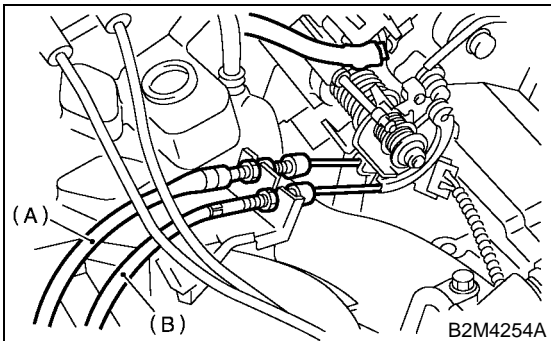

- 7) Remove power steering pump and tank from brackets.

- (1) Remove resonator chamber. <Ref. to IN(SOHC)-8, REMOVAL, Resonator Chamber.>
- (2) Remove front side V-belt. <Ref. to ME(SOHC)-42, REMOVAL, V-belt.>
- (3) Remove bolts which hold power steering pipes onto intake manifold protector.

**NOTE:**

Do not disconnect power steering hose.

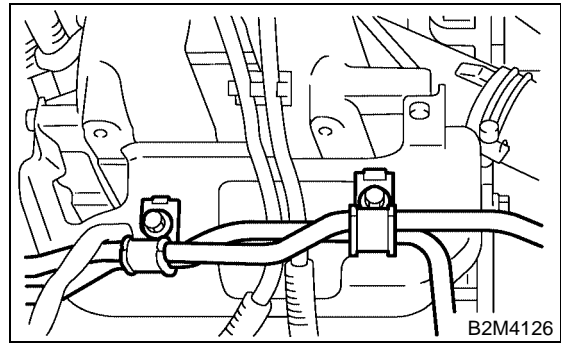

- (4) Remove bolts which install power steering pump bracket.

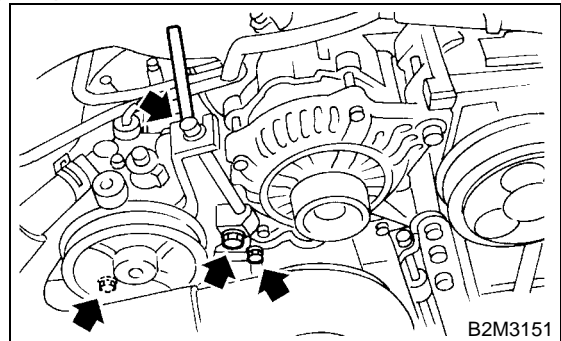

- (5) Disconnect connector from power steering pump switch.

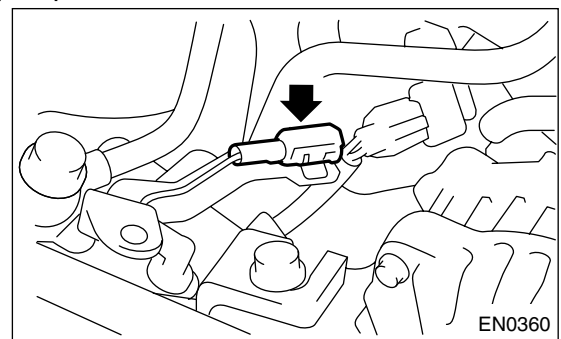

- (6) Remove power steering tank from the bracket by pulling it upwards.

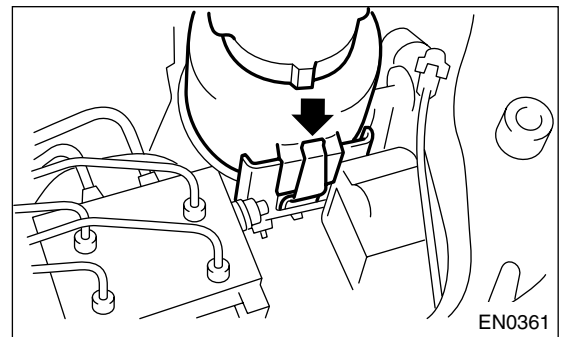



# INTAKE MANIFOLD

## FUEL INJECTION (FUEL SYSTEMS)

- (7) Place power steering pump and tank on the right side wheel apron.

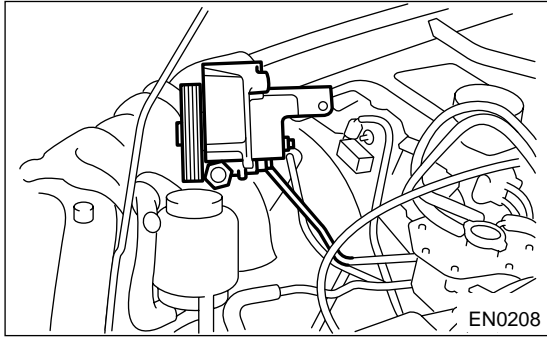

- 8) Disconnect spark plug cords from spark plugs.  
9) Disconnect PCV hose from intake manifold.

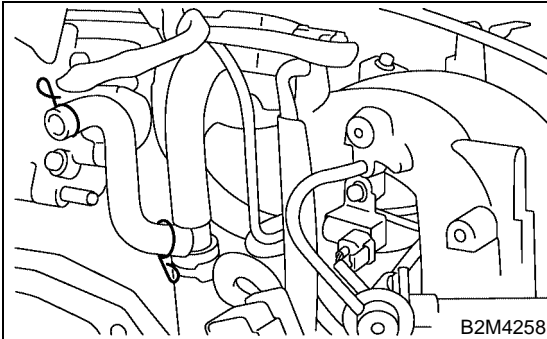

- 10) Disconnect engine coolant hose from throttle body.

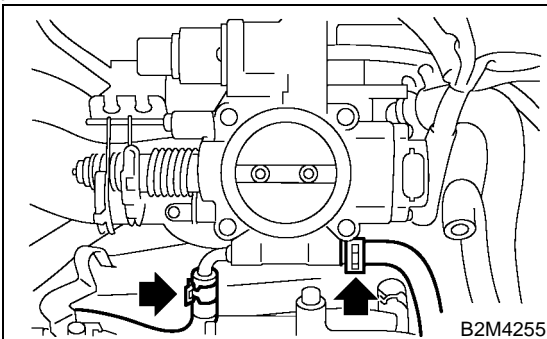

- 11) Disconnect brake booster hose.

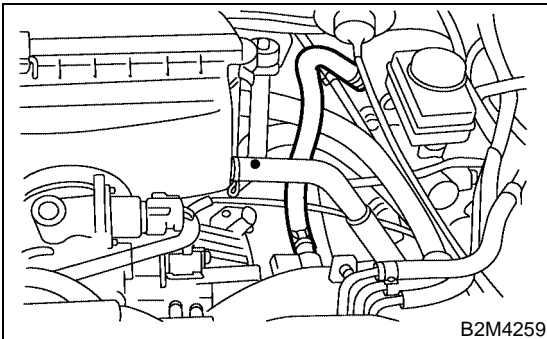

- 12) Remove air cleaner case stay RH and engine harness bracket, and disconnect engine harness connectors from bulkhead harness connectors.



- 13) Disconnect connectors from engine coolant temperature sensor.

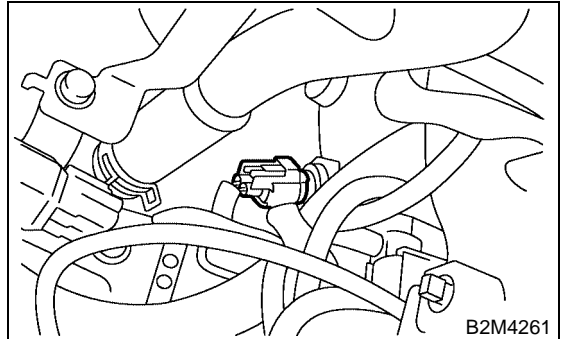

- 14) Disconnect knock sensor connector.

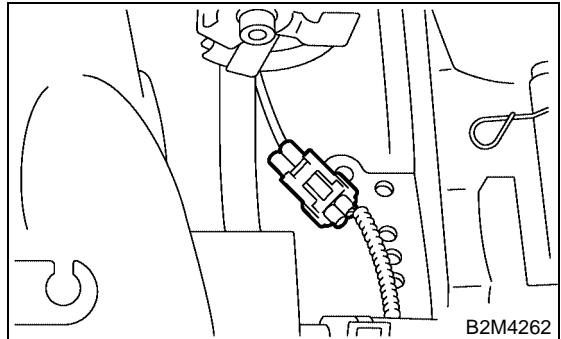

- 15) Disconnect connector from crankshaft position sensor.

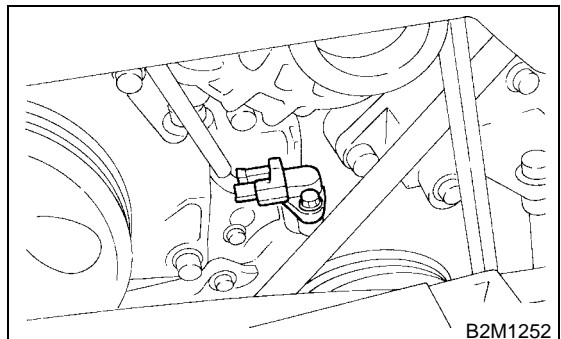

# INTAKE MANIFOLD

FUEL INJECTION (FUEL SYSTEMS)

16) Disconnect connector from oil pressure switch.

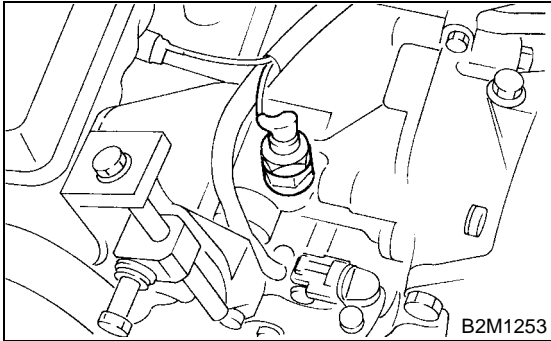

17) Disconnect connector from camshaft position sensor.

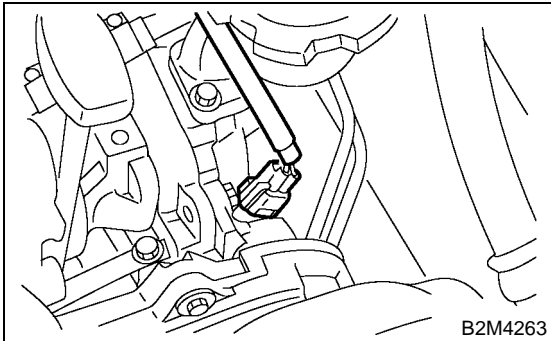

18) Disconnect fuel hoses from fuel pipes.

### WARNING:

- Do not spill fuel.
- Catch fuel from hoses in a container or cloth.

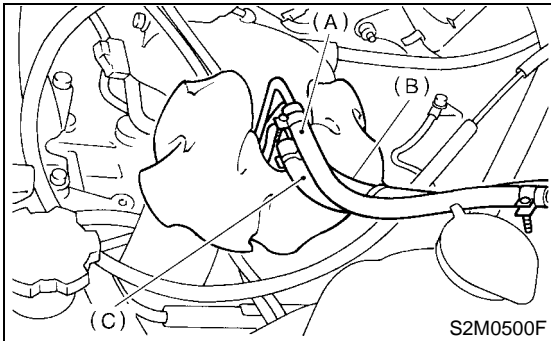

- (A) Fuel delivery hose
- (B) Return hose
- (C) Evaporation hose

19) Remove bolts which hold intake manifold onto cylinder heads.

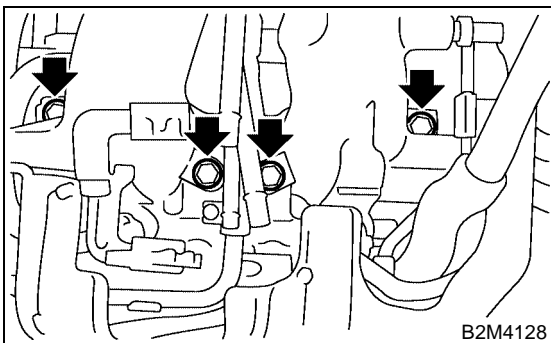

20) Remove intake manifold.

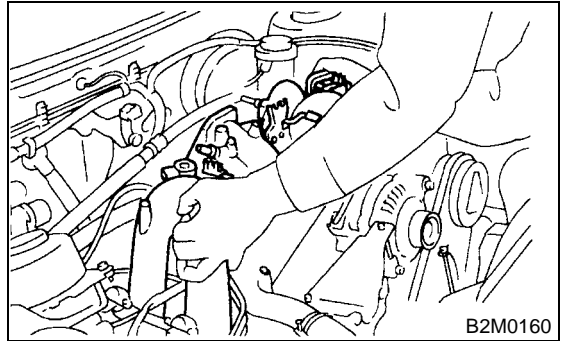

## B: INSTALLATION

1) Install intake manifold onto cylinder heads.

### CAUTION:

Always use new gaskets.

*Tightening torque:*

**25 N·m (2.5 kgf·m, 18.1 ft·lb)**

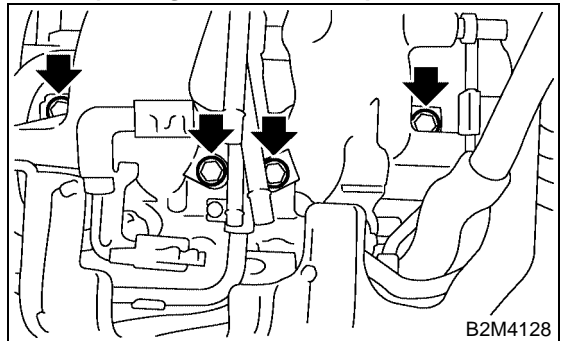

2) Connect fuel hoses.

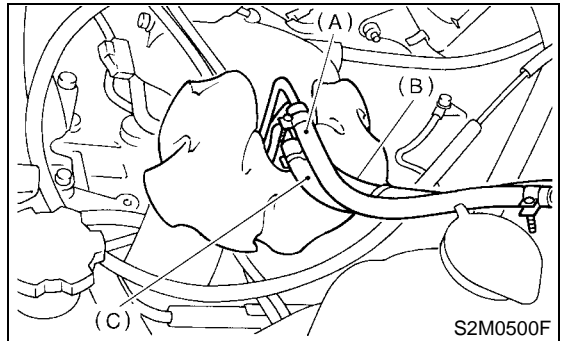

- (A) Fuel delivery hose
- (B) Return hose
- (C) Evaporation hose

# INTAKE MANIFOLD

## FUEL INJECTION (FUEL SYSTEMS)

3) Connect connector to camshaft position sensor.

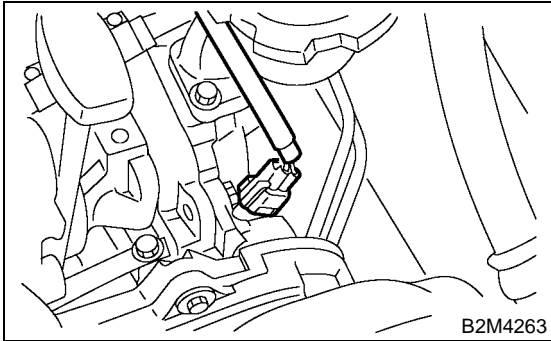

4) Connect connector to oil pressure switch.

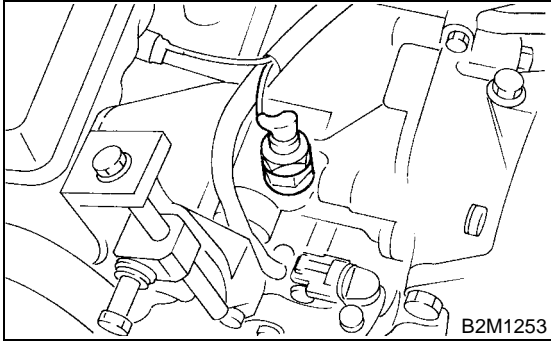

5) Connect connector to crankshaft position sensor.

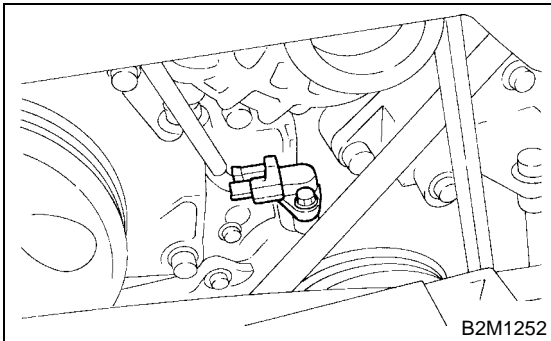

6) Connect knock sensor connector.

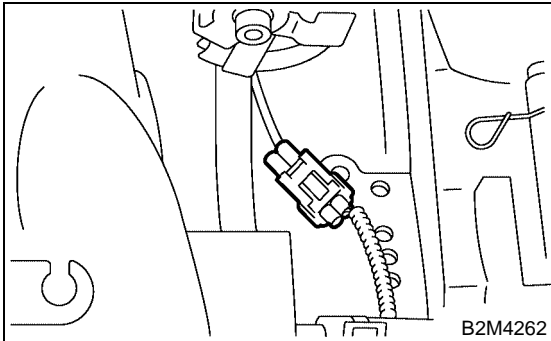

7) Connect connectors to engine coolant temperature sensor.

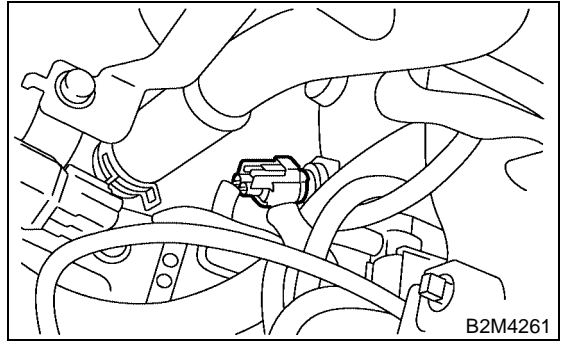

8) Install air cleaner case stay RH and engine harness bracket, and connect engine harness connectors to bulkhead connectors.



9) Connect brake booster hose.

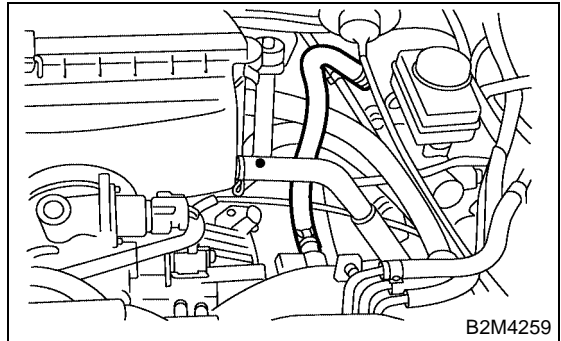

10) Connect engine coolant hose to throttle body.

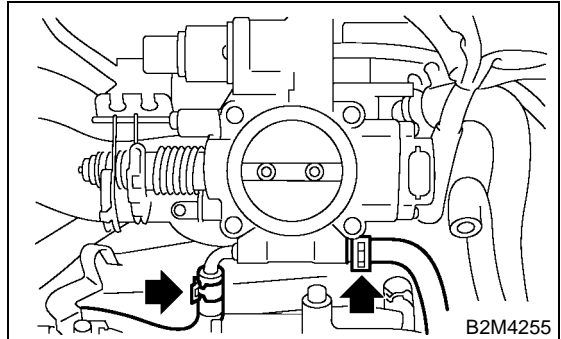

# INTAKE MANIFOLD

FUEL INJECTION (FUEL SYSTEMS)

11) Connect PCV hose to intake manifold.

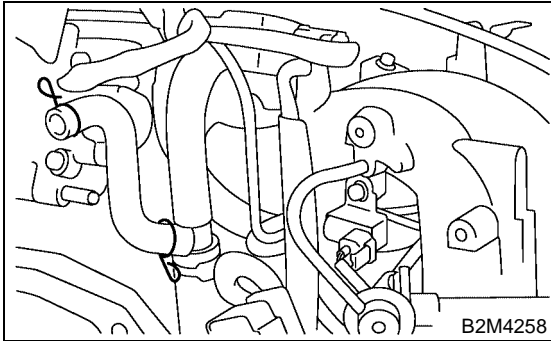

12) Connect spark plug cords to spark plugs.

13) Install power steering pump and tank on brackets.

(1) Install power steering tank on bracket.

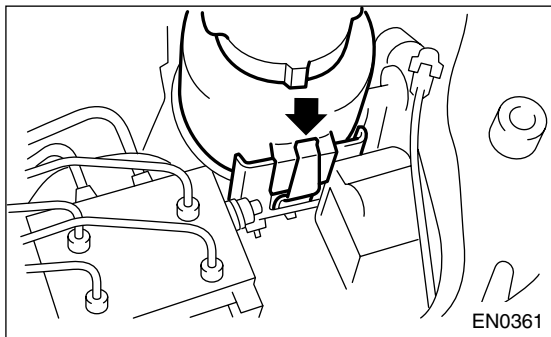

(2) Connect connector to power steering pump switch.

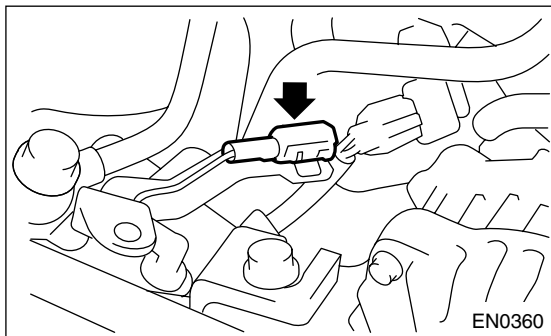

(3) Tighten bolts which install power steering pump on bracket.

**Tightening torque:**

**20.1 N·m (2.05 kgf·m, 14.8 ft·lb)**

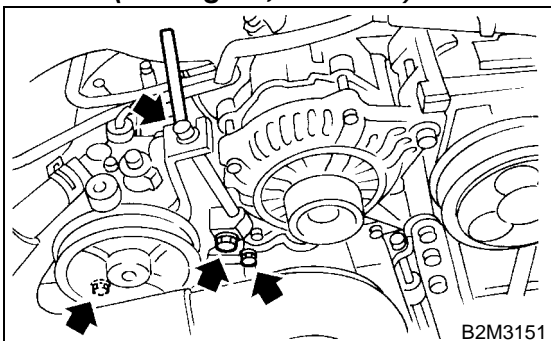

(4) Install power steering pipes onto right side intake manifold protector.

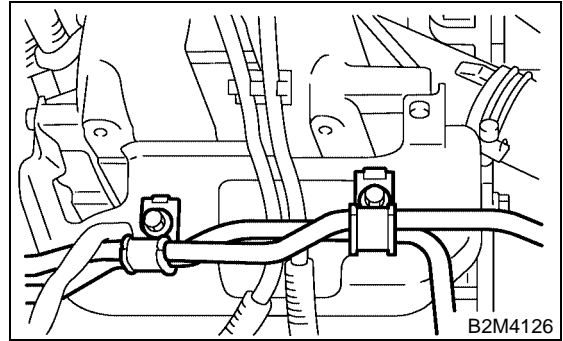

(5) Install V-belt. <Ref. to ME(SOHC)-42, INSTALLATION, V-belt.>

(6) Install resonator chamber.

**Tightening torque:**

**33 N·m (3.4 kgf·m, 24.6 ft·lb)**

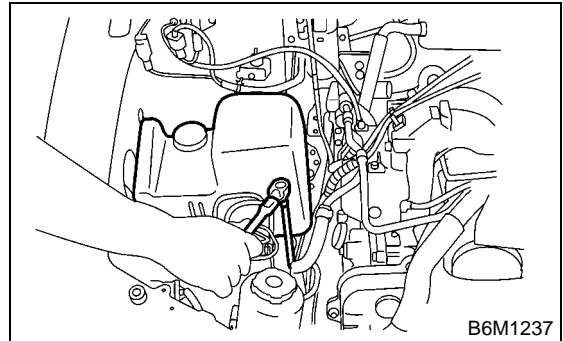

14) Connect accelerator cable (A).

15) Connect cruise control cable (B). (With cruise control models)

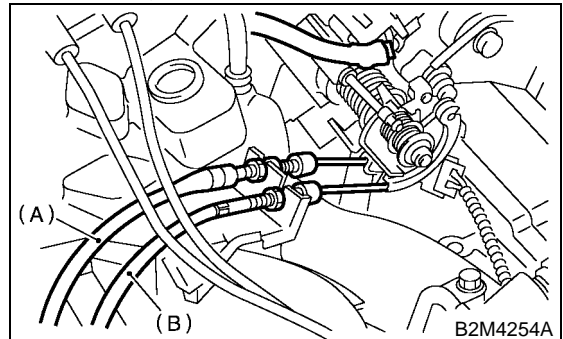

16) Install air intake duct and air cleaner assembly. <Ref. to IN(SOHC)-7, INSTALLATION, Air Intake Duct.> and <Ref. to IN(SOHC)-6, INSTALLATION, Air Cleaner Case.>

# INTAKE MANIFOLD

## FUEL INJECTION (FUEL SYSTEMS)

17) Connect connector to fuel pump relay.



18) Connect battery ground cable.

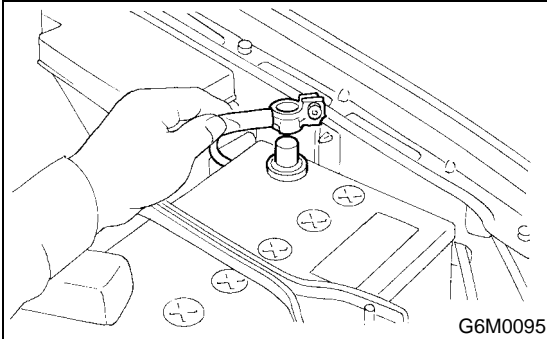

### C: DISASSEMBLY

1) Disconnect engine ground terminal from intake manifold.

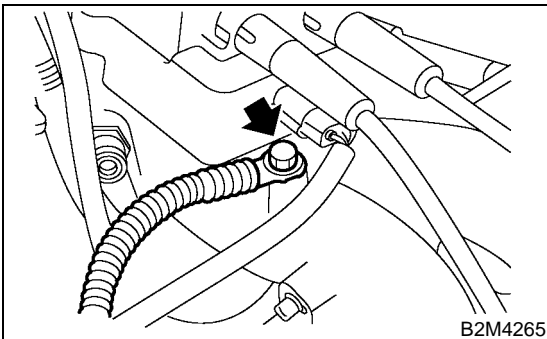

2) Disconnect connector from ignition coil and ignitor assembly.

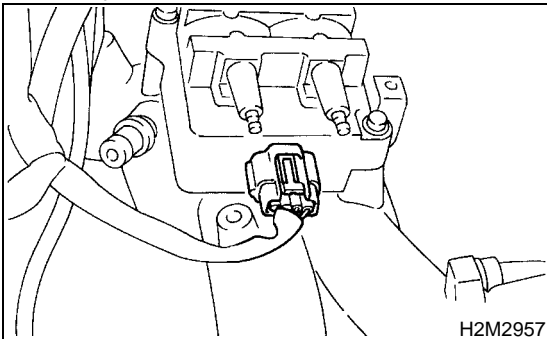

3) Remove ignition coil and ignitor assembly.

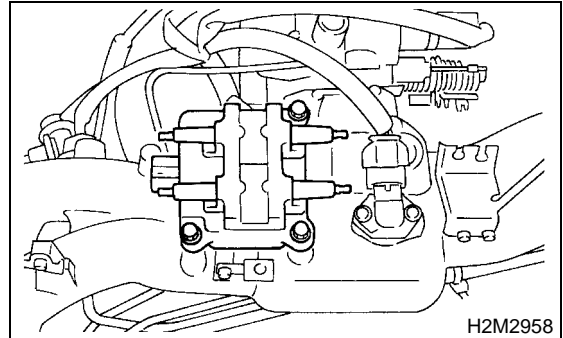

4) Disconnect connector from intake air temperature and pressure sensor.

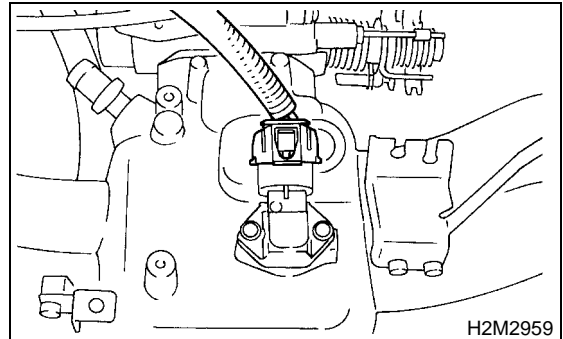

5) Remove intake air temperature and pressure sensor from intake manifold.

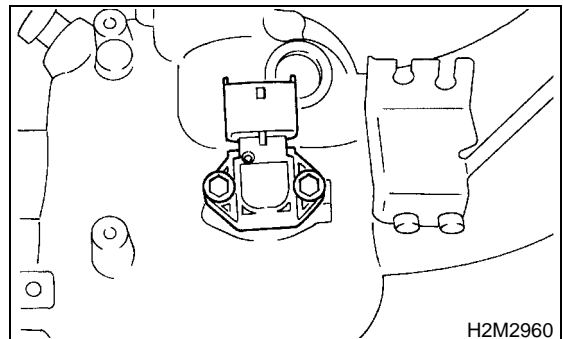

6) Disconnect connectors from throttle position sensor and idle air control solenoid valve.

7) Remove throttle body..

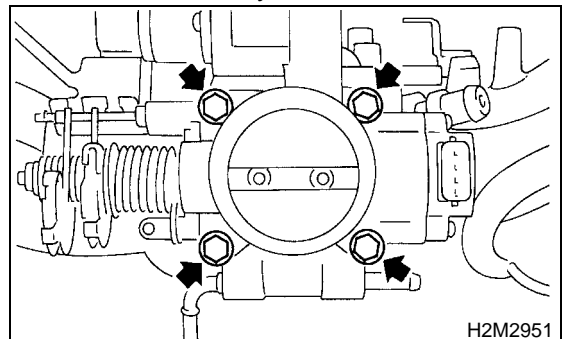

# INTAKE MANIFOLD

## FUEL INJECTION (FUEL SYSTEMS)

8) Disconnect pressure regulator vacuum hose from intake manifold.

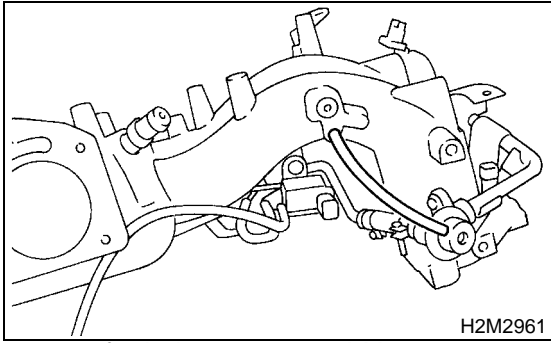

9) Remove fuel pipe protector LH.

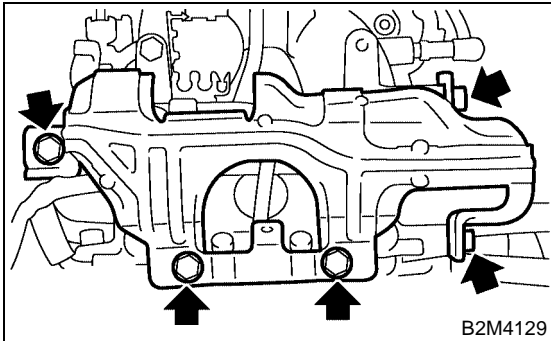

10) Remove fuel pipe protector RH.

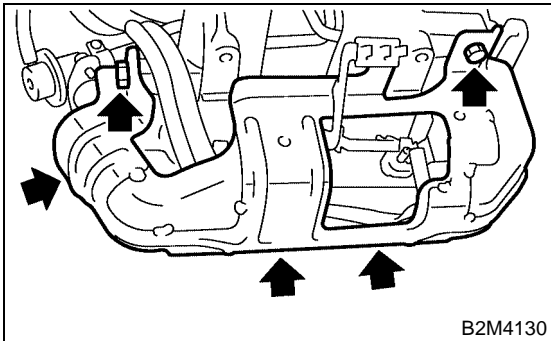

11) Disconnect connectors from fuel injectors.

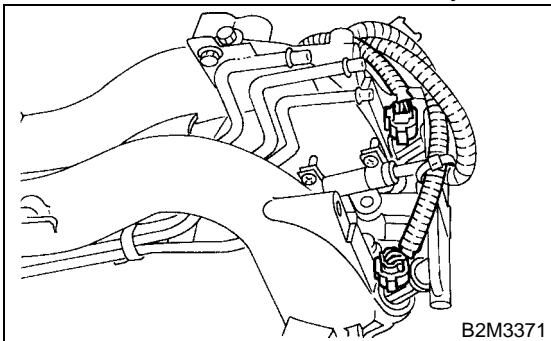

12) Disconnect connector from purge control solenoid valve.

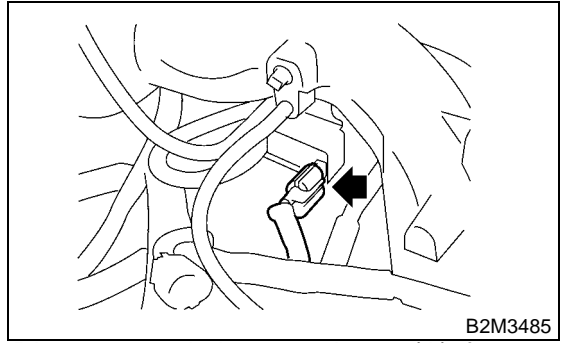

13) Disconnect air by-pass hose (A) from purge control solenoid valve.

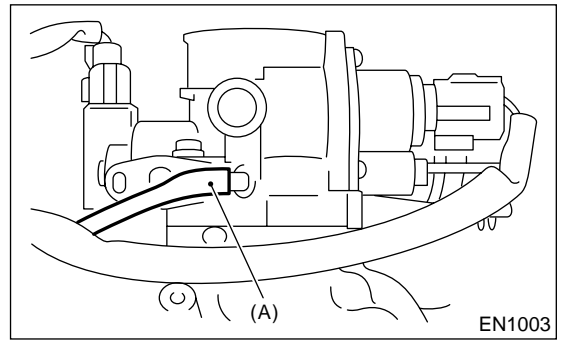

14) Remove harness bands (A) and harness bracket (B) which hold engine harness onto intake manifold.

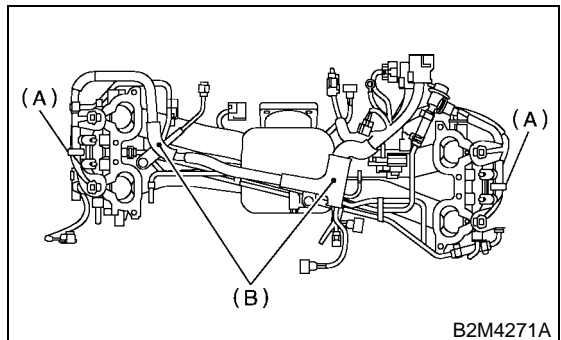

15) Remove engine harness from intake manifold.

16) Remove purge control solenoid valve.

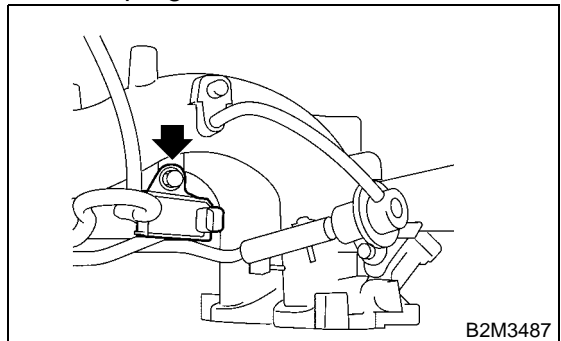

# INTAKE MANIFOLD

## FUEL INJECTION (FUEL SYSTEMS)

17) Remove bolt which installs injector pipe on intake manifold as shown in figure.

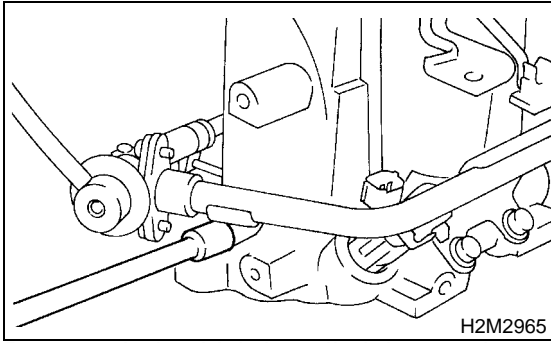

18) Remove bolt which installs injector pipe on intake manifold.

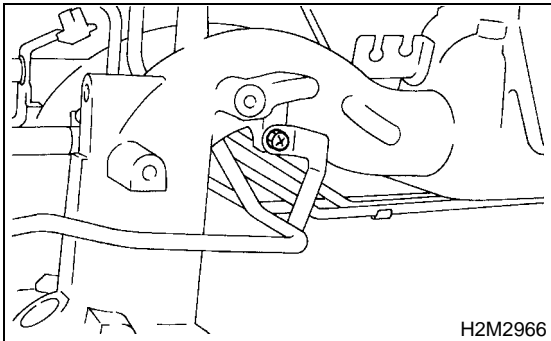

19) Remove two bolts which hold fuel pipes on the left side of intake manifold.

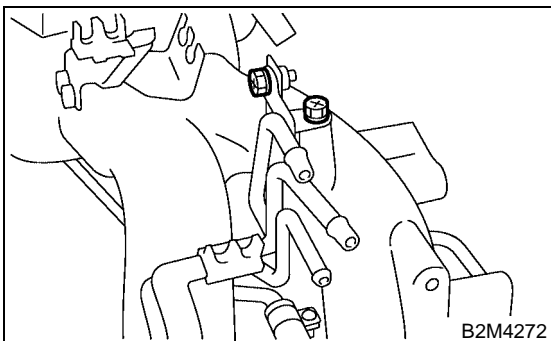

20) Remove fuel injectors.

(1) Remove fuel injector securing clip.

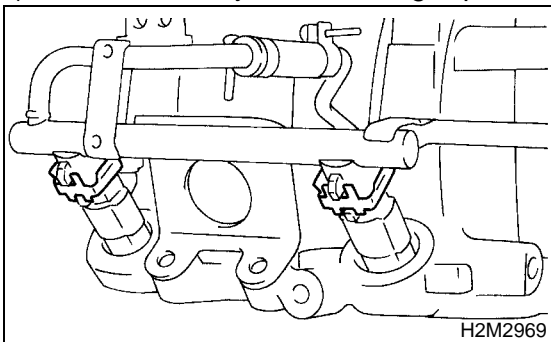

(2) Remove fuel injector while lifting up fuel injector pipe.

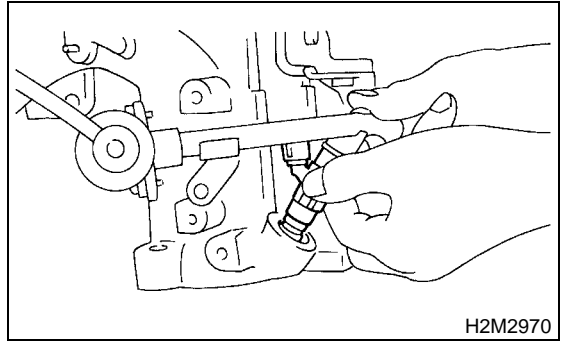

21) Loosen clamp which holds front left side fuel hose to injector pipe and remove the pipe from clamp.

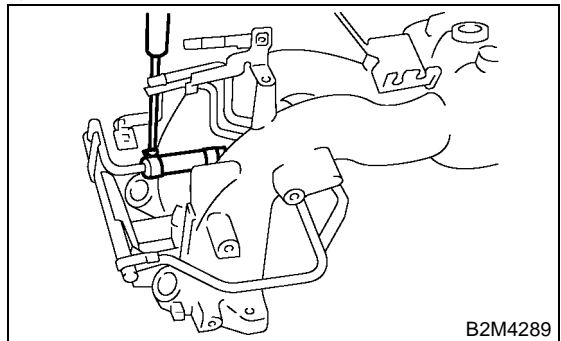

22) Loosen clamp which holds front right side fuel hose to injector pipe and remove the pipe from clamp.

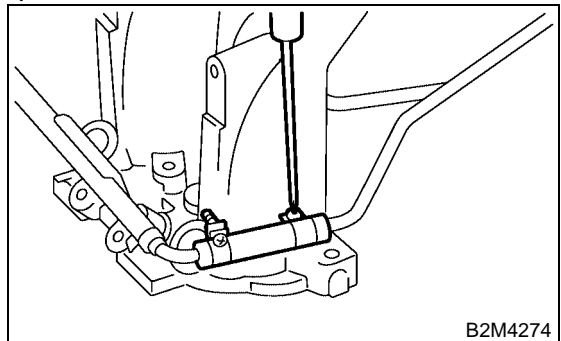

23) Remove fuel injector pipe.

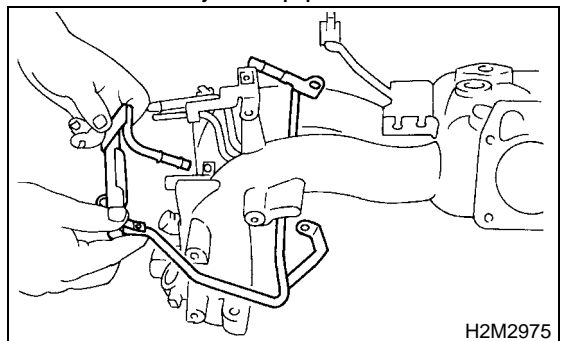

# INTAKE MANIFOLD

FUEL INJECTION (FUEL SYSTEMS)

24) Remove bolt which installs fuel pipes on intake manifold.

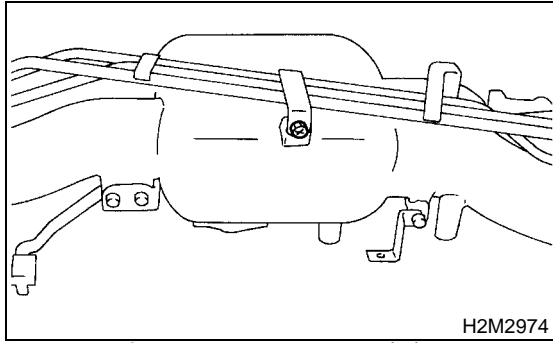

25) Remove fuel pipe assembly (B) and pressure regulator (A), from intake manifold.

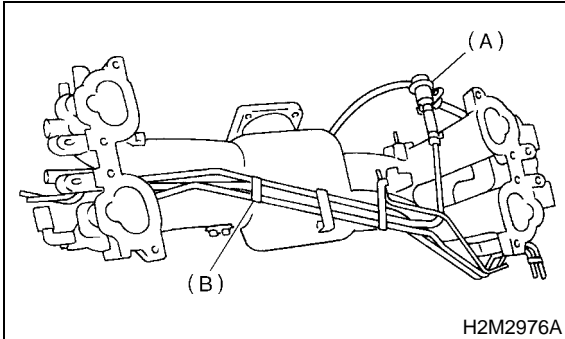

## D: ASSEMBLY

1) Install fuel pipe assembly (B) and pressure regulator (A), etc. to intake manifold.

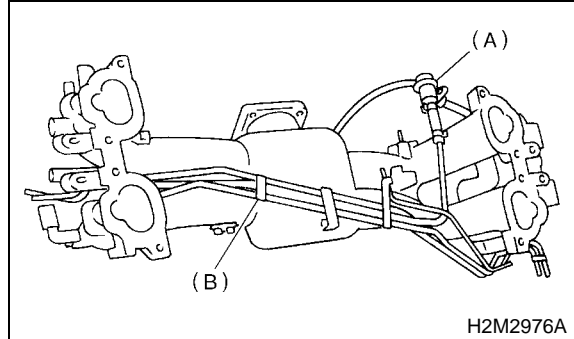

2) Tighten bolt which installs fuel pipes on intake manifold.

### Tightening torque:

**4.9 N·m (0.5 kgf·m, 3.6 ft·lb)**

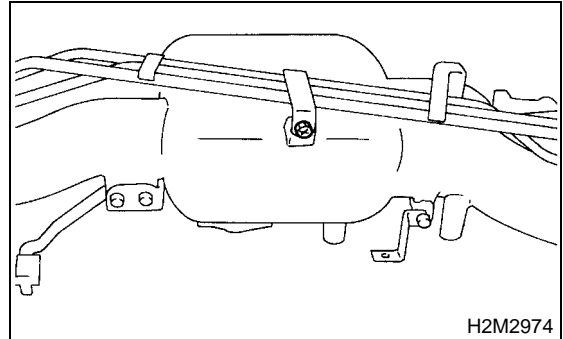

3) Connect right side fuel hose to injector pipe, and tighten clamp screw.

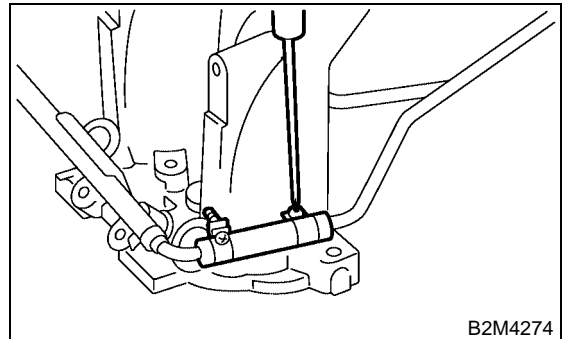

4) Install fuel injector pipe.

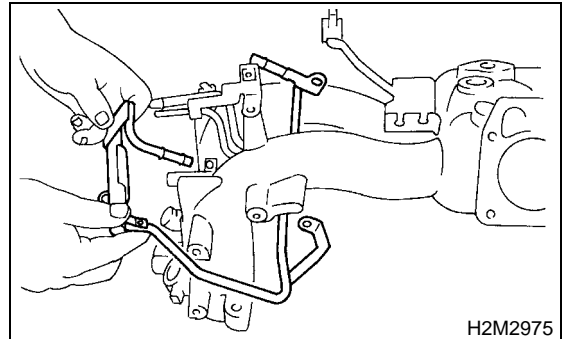



# INTAKE MANIFOLD

## FUEL INJECTION (FUEL SYSTEMS)

5) Connect left side fuel hose to injector pipe, and tighten clamp screw.

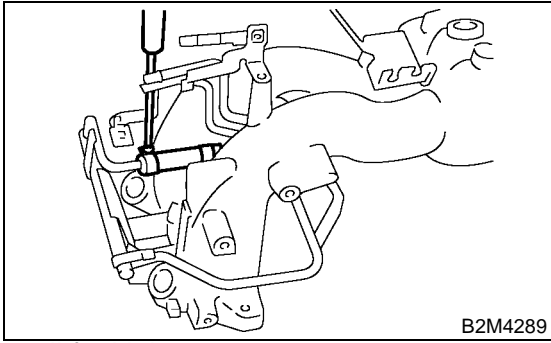

6) Install fuel injectors.

**CAUTION:**  
Always use new o-rings.

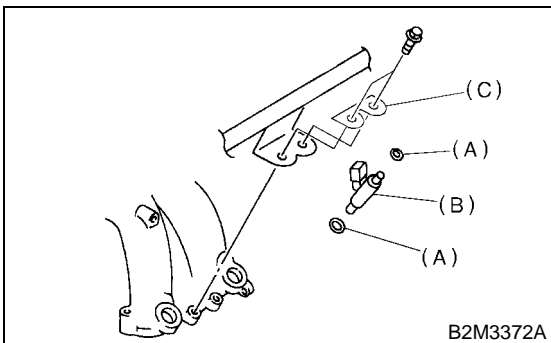

- (A) O-ring
- (B) Fuel injector
- (C) Intake manifold protector

**NOTE:**  
Do not forget to install the fuel injector securing clip.

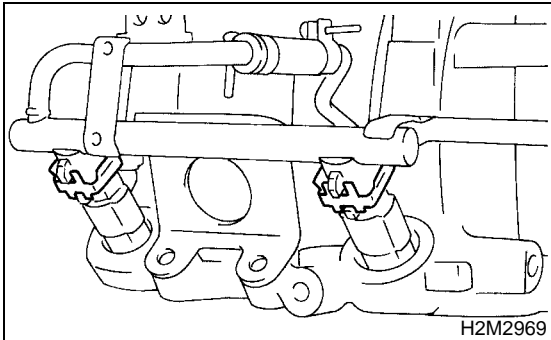

7) Tighten bolt which installs injector pipe on intake manifold.

**Tightening torque:**  
**5.0 N·m (0.51 kgf-m, 3.7 ft-lb)**

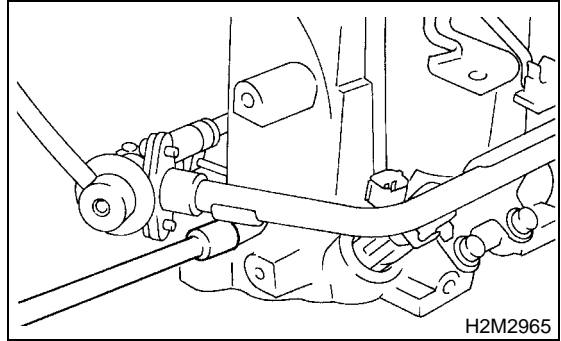

8) Tighten two bolts which install fuel pipes on the left side of intake manifold.

**Tightening torque:**  
**5.0 N·m (0.51 kgf-m, 3.7 ft-lb)**

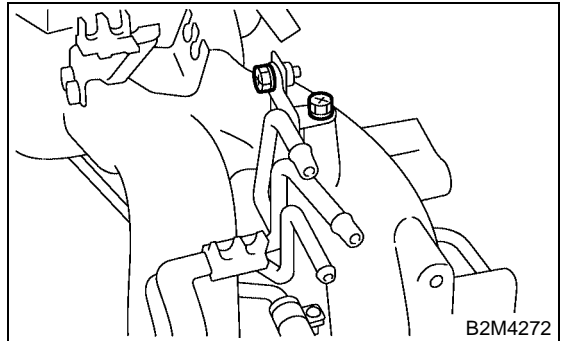

9) Tighten bolt which install injector pipe on intake manifold.

**Tightening torque:**  
**5.0 N·m (0.51 kgf-m, 3.7 ft-lb)**

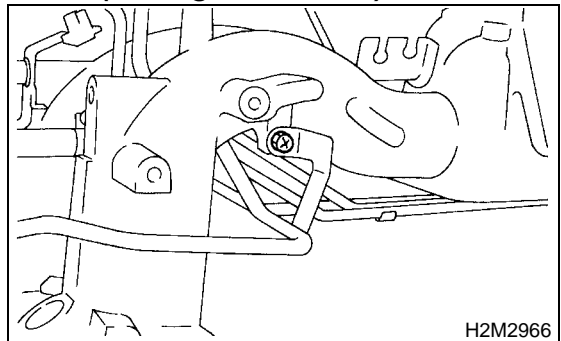

# INTAKE MANIFOLD

FUEL INJECTION (FUEL SYSTEMS)

10) Install purge control solenoid valve.

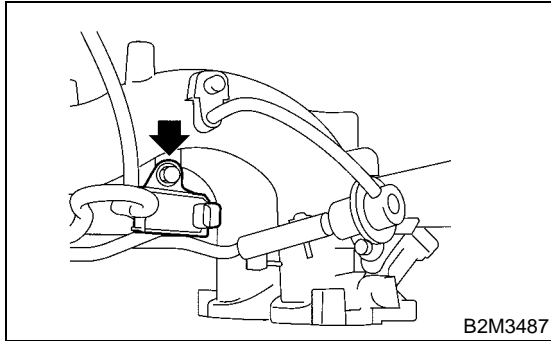

11) Connect hoses to purge control solenoid valve.

**CAUTION:**

**Carefully connect the evaporation hoses.**

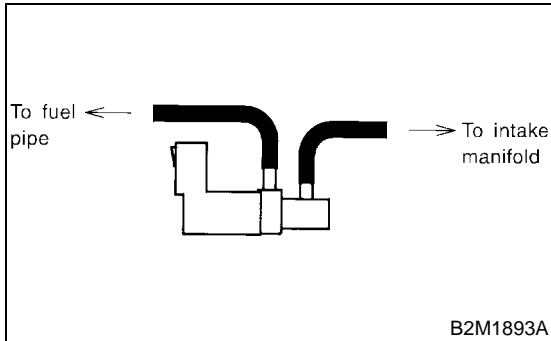

12) Install engine harness onto intake manifold.

13) Connect connectors to fuel injectors and purge control solenoid valve.

14) Hold engine harness by harness band (A) and harness bracket (B).

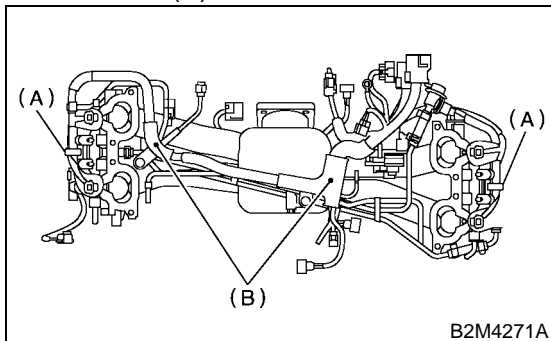

**NOTE:**

Do not use harness band on harnesses where they are supposed to be protected by the fuel pipe protector.

15) Install fuel pipe protector RH.

**Tightening torque:**

**19 N·m (1.9 kgf·m, 13.7 ft·lb)**

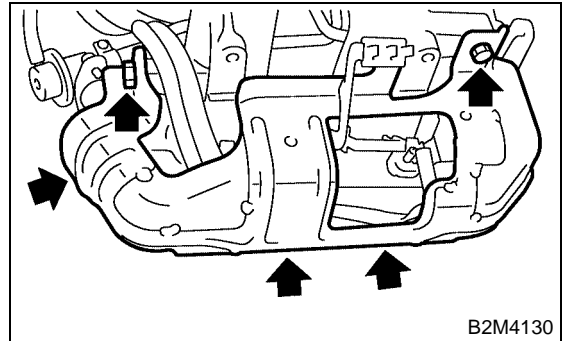

16) Install fuel pipe protector LH.

**Tightening torque:**

**19 N·m (1.9 kgf·m, 13.7 ft·lb)**

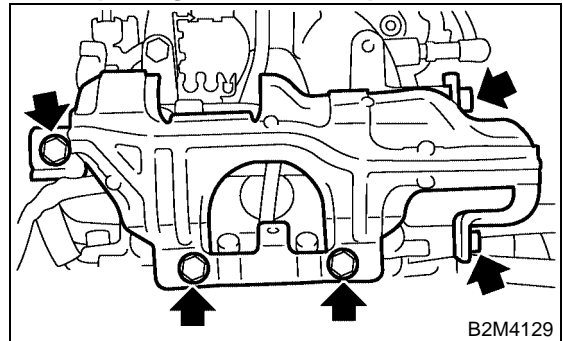

17) Connect pressure regulator vacuum hose to intake manifold.

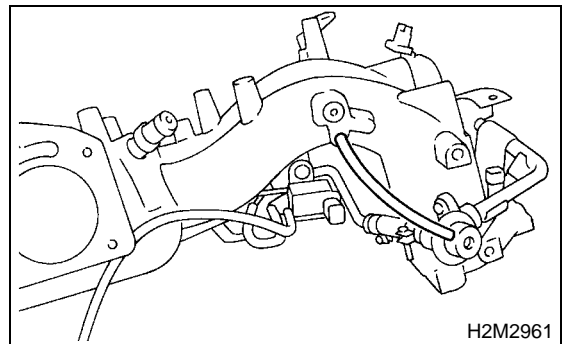

# INTAKE MANIFOLD

## FUEL INJECTION (FUEL SYSTEMS)

18) Install throttle body to intake manifold.

**CAUTION:**

Replace gasket with a new one.

**Tightening torque:**

**22 N·m (2.2 kgf·m, 15.9 ft·lb)**

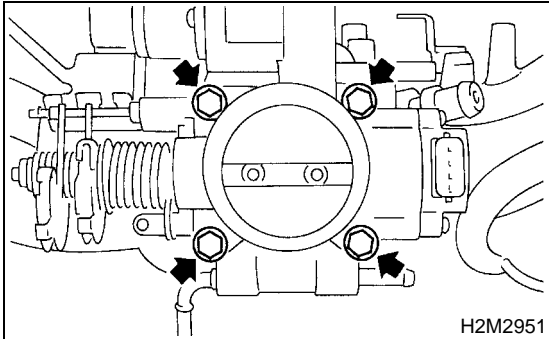

19) Connect air by-pass hose (A) from purge control solenoid valve to intake manifold.

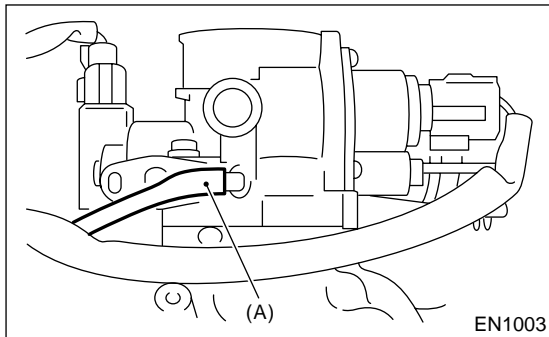

20) Install intake air temperature and pressure sensor.

**Tightening torque:**

**3.4 N·m (0.35 kgf·m, 2.5 ft·lb)**

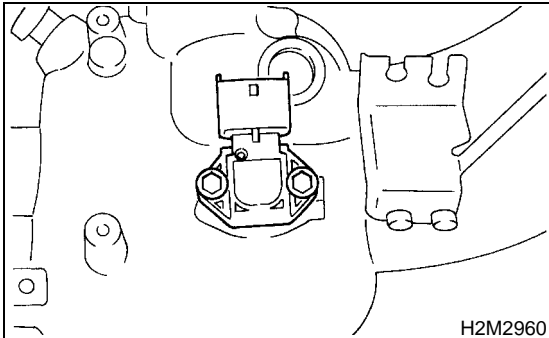

**CAUTION:**

Replace O-ring with new one.

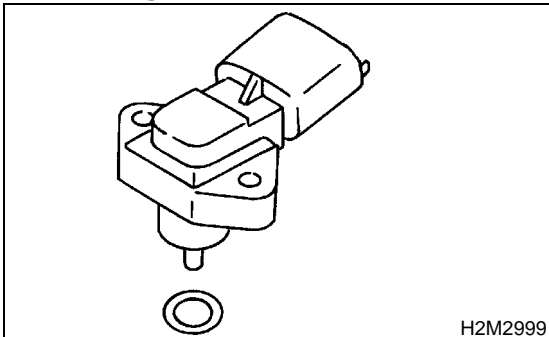

21) Connect connector to intake air temperature and pressure sensor.

22) Connect connectors to throttle position sensor and idle air control solenoid valve.

23) Install ignition coil and ignitor assembly.

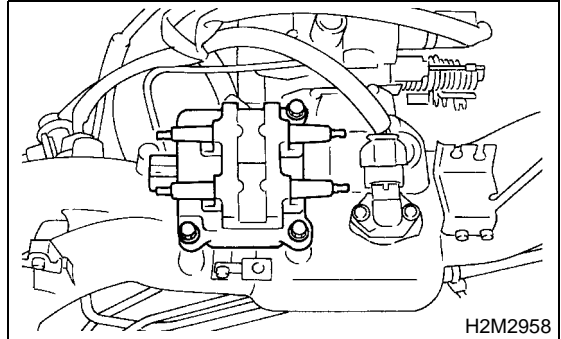

24) Connect connector to ignition coil and ignitor assembly.

25) Install engine ground terminal to intake manifold.

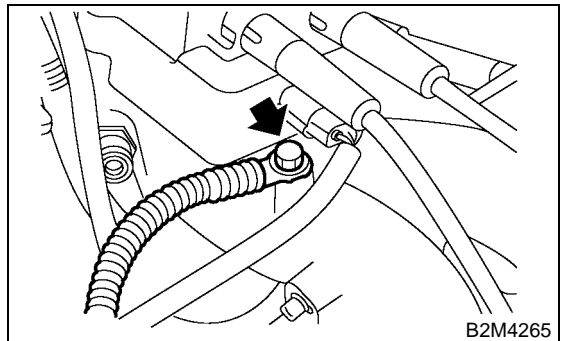

### E: INSPECTION

Make sure the fuel pipe and fuel hoses are not cracked and that connections are tight.

# ENGINE COOLANT TEMPERATURE SENSOR

FUEL INJECTION (FUEL SYSTEMS)

## 4. Engine Coolant Temperature Sensor

### A: REMOVAL

- 1) Disconnect battery ground cable.

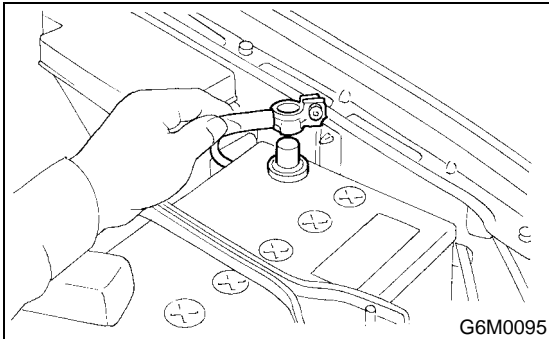

- 2) Remove air intake duct and air cleaner assembly. <Ref. to IN(SOHC)-7, REMOVAL, Air Intake Duct.> and <Ref. to IN(SOHC)-6, REMOVAL, Air Cleaner Case.>

- 3) Disconnect connector from engine coolant temperature sensor.

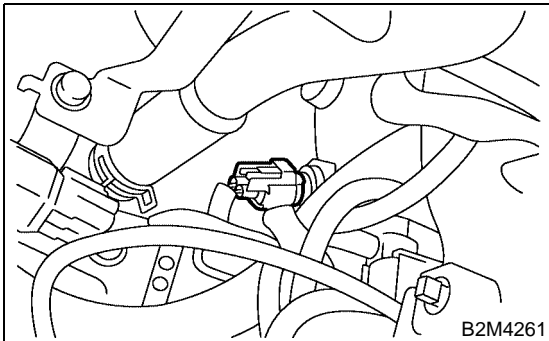

- 4) Remove engine coolant temperature sensor.

### B: INSTALLATION

Install in the reverse order of removal.

#### *Tightening torque:*

**16 N·m (0.16 kgf-m, 1.2 ft-lb)**

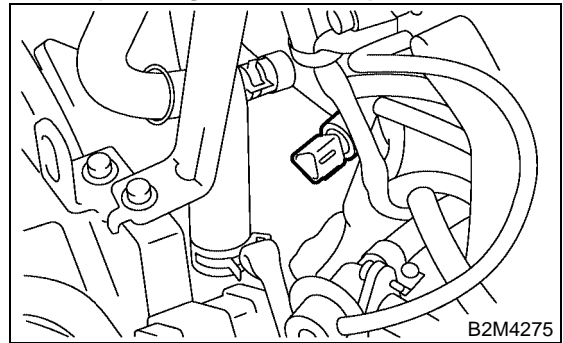

# CRANKSHAFT POSITION SENSOR

FUEL INJECTION (FUEL SYSTEMS)

## 5. Crankshaft Position Sensor

### A: REMOVAL

1) Disconnect battery ground cable.

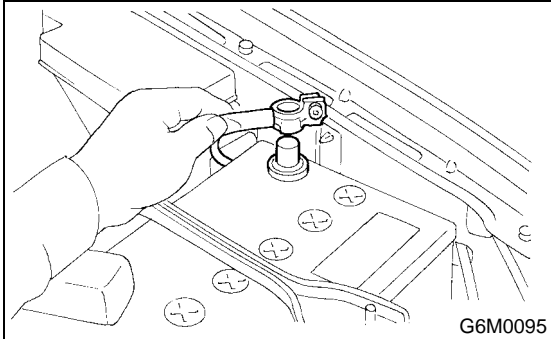

2) Remove bolt which install crankshaft position sensor to cylinder block.

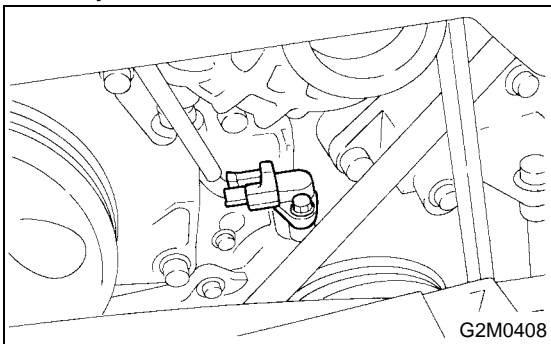

3) Remove crankshaft position sensor, and disconnect connector from it.

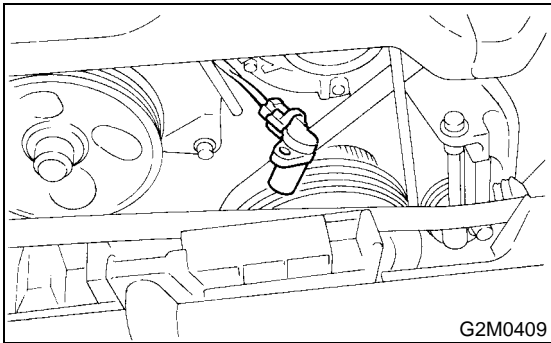

### B: INSTALLATION

Install in the reverse order of removal.

**Tightening torque:**

**T: 6.4 N·m (0.65 kgf-m, 4.7 ft-lb)**

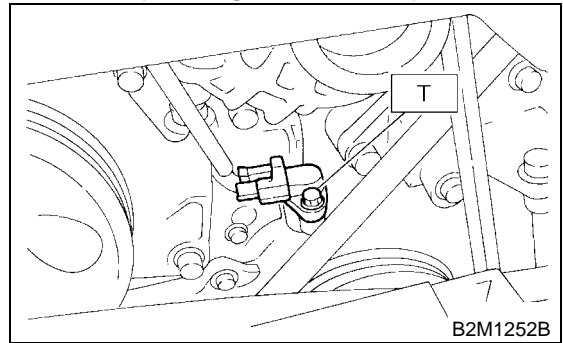

# CAMSHAFT POSITION SENSOR

FUEL INJECTION (FUEL SYSTEMS)

## 6. Camshaft Position Sensor

### A: REMOVAL

1) Disconnect battery ground cable.

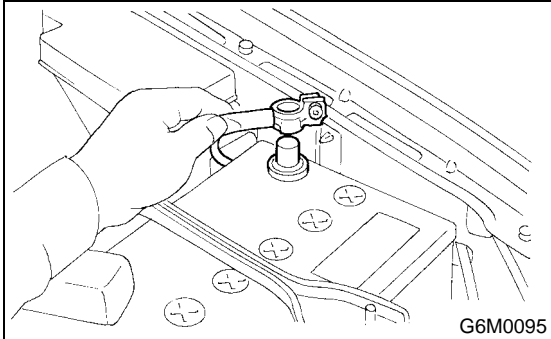

2) Disconnect connector from camshaft position sensor.

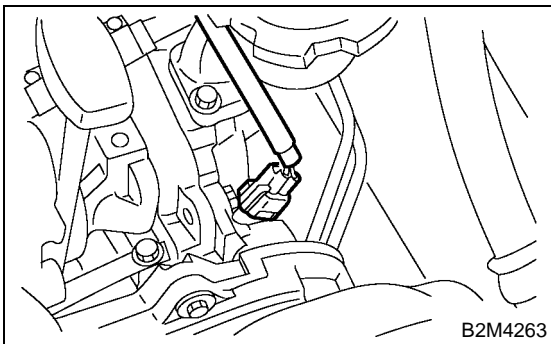

3) Remove bolt which installs camshaft position sensor to camshaft position sensor support.

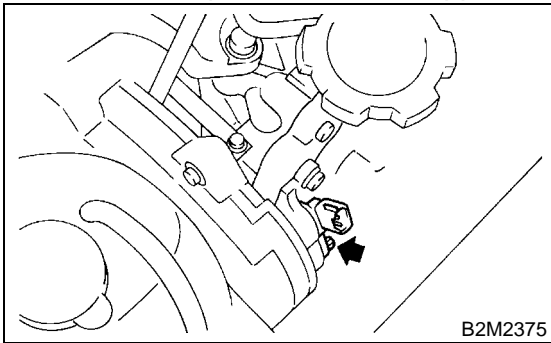

4) Remove bolt which installs camshaft position sensor support to camshaft cap LH.

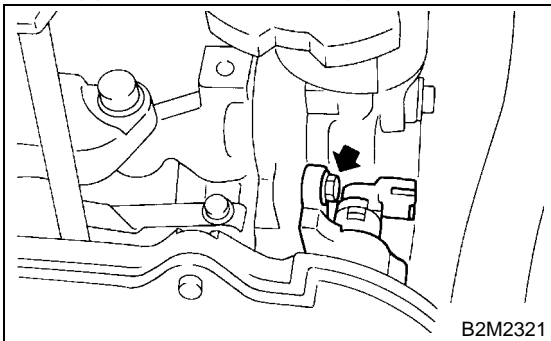

5) Remove camshaft position sensor and camshaft position sensor support as a unit.

6) Remove camshaft position sensor itself.

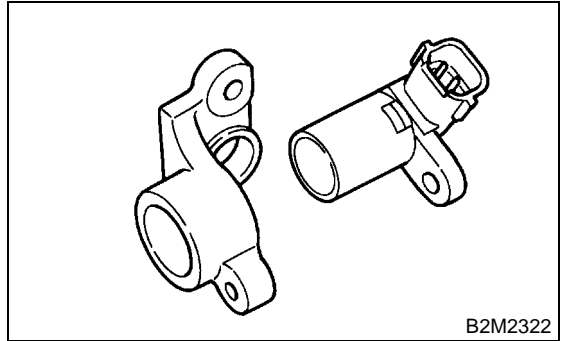

### B: INSTALLATION

Install in the reverse order of removal.

#### *Tightening torque:*

- **Camshaft position sensor support;**  
**6.4 N·m (0.65 kgf-m, 4.7 ft-lb)**
- **Camshaft position sensor;**  
**6.4 N·m (0.65 kgf-m, 4.7 ft-lb)**

# KNOCK SENSOR

FUEL INJECTION (FUEL SYSTEMS)

## 7. Knock Sensor

### A: REMOVAL

- 1) Disconnect battery ground cable from battery ground terminal.

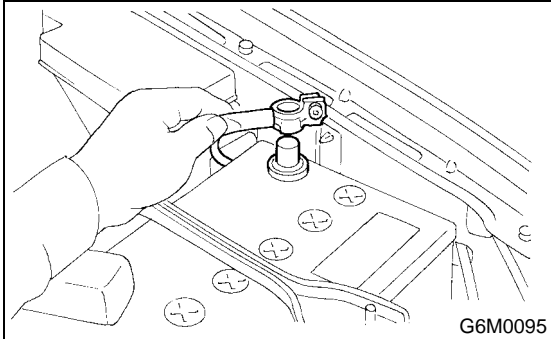

- 2) Remove air cleaner case.

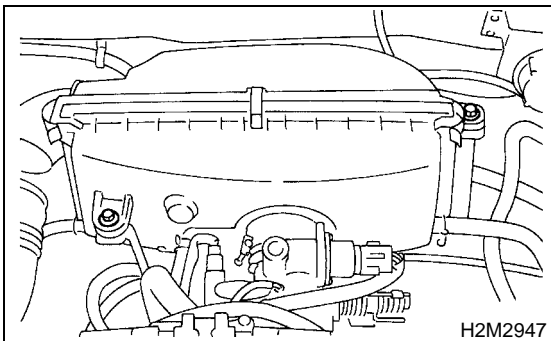

- 3) Disconnect knock sensor connector.

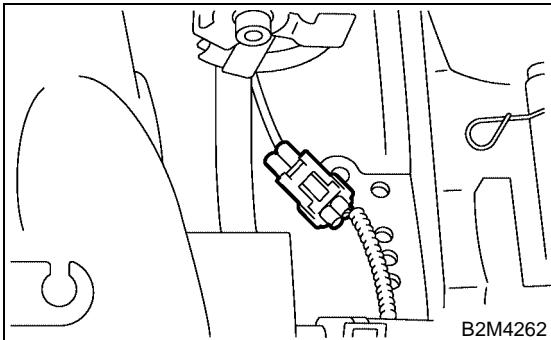

- 4) Remove knock sensor from cylinder block.

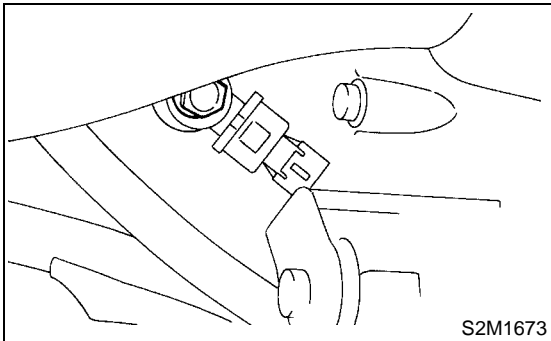

### B: INSTALLATION

- 1) Install knock sensor to cylinder block.

#### *Tightening torque:*

**24 N·m (2.4 kgf·m, 17.4 ft·lb)**

#### NOTE:

The extraction area of the knock sensor cord must be positioned at a 45° angle relative to the engine rear.

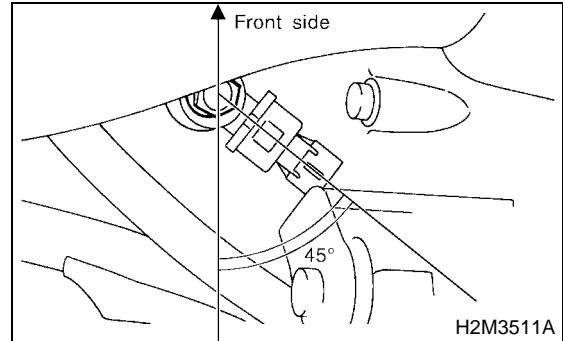

- 2) Connect knock sensor connector.

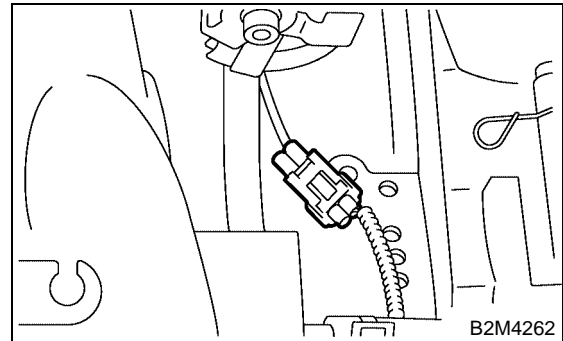

- 3) Install air cleaner case.

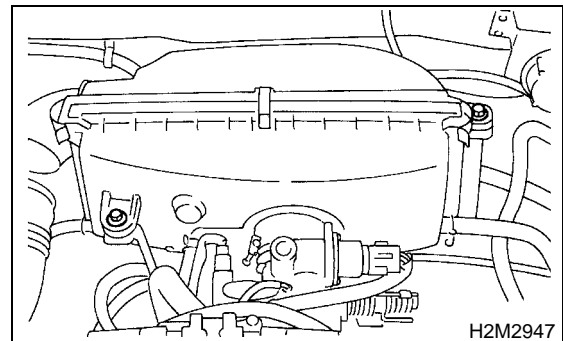

- 4) Connect battery ground cable.

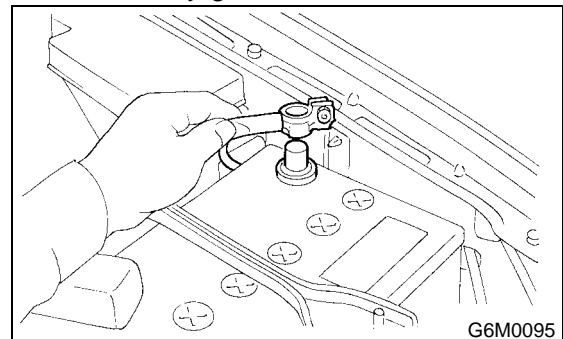

# THROTTLE POSITION SENSOR

FUEL INJECTION (FUEL SYSTEMS)

## 8. Throttle Position Sensor

### A: REMOVAL

1) Disconnect battery ground cable.

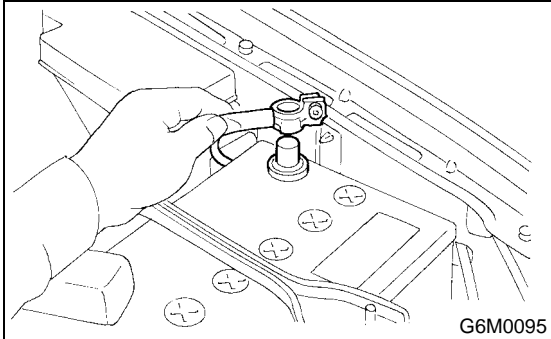

2) Disconnect connector from throttle position sensor.

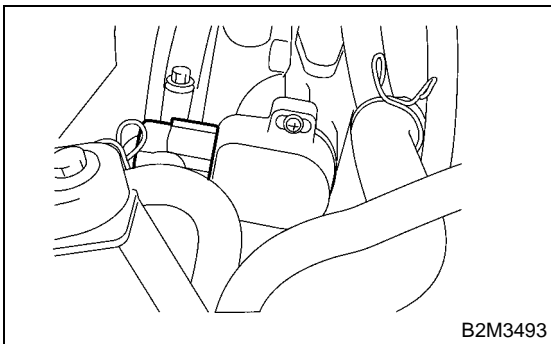

3) Remove throttle position sensor holding screws, and remove it.

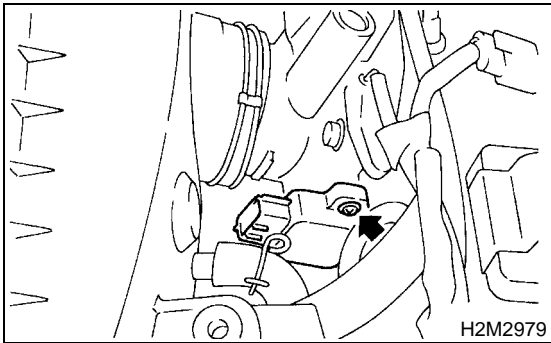

### B: INSTALLATION

Install in the reverse order of removal.

**Tightening torque:**

**1.6 N·m (0.16 kgf-m, 1.2 ft-lb)**

**CAUTION:**

**When installing throttle position sensor, adjust to the specified data.**

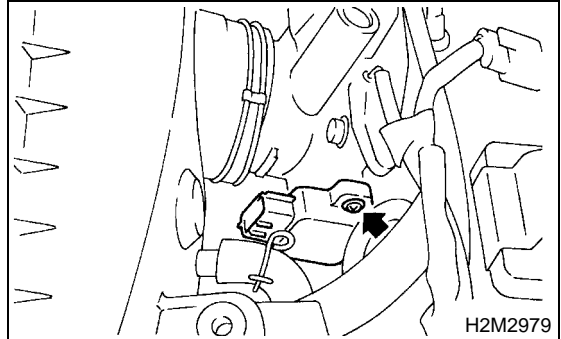



# THROTTLE POSITION SENSOR

## FUEL INJECTION (FUEL SYSTEMS)

### C: ADJUSTMENT

- 1) Turn ignition switch to OFF.
- 2) Loosen throttle position sensor holding screws.

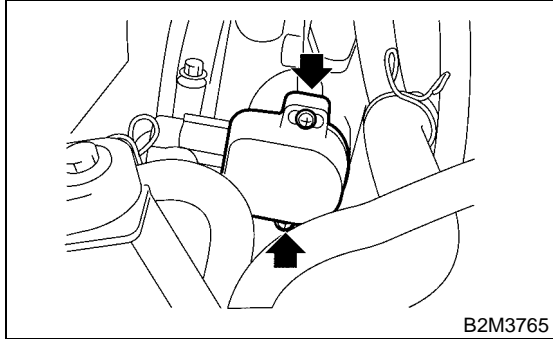

- 3) When using voltage meter;
  - (1) Take out ECM.
  - (2) Turn ignition switch to ON.
  - (3) Adjust throttle position sensor to the proper position to allow the voltage signal to ECM to be in specification.

**Connector & terminal / Specified voltage**  
**(B136) No. 15 — (B136) No. 17 / 0.45 — 0.55 V**  
**[Fully closed.]**

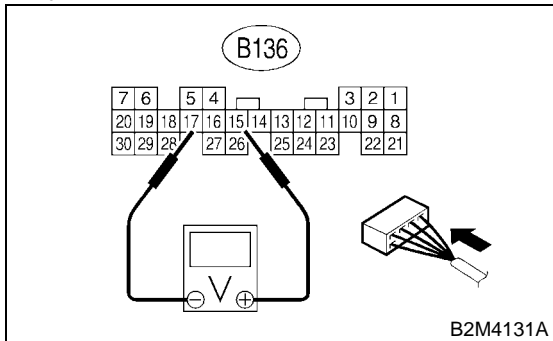

- (4) Tighten throttle position sensor holding screws.

**Tightening torque:**  
**1.6 N·m (0.16 kgf·m, 1.2 ft·lb)**

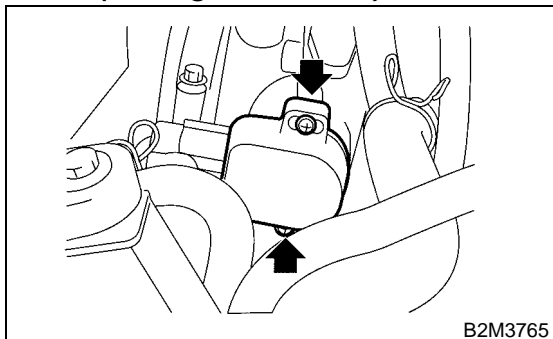

- 4) When using Subaru Select Monitor;
  - (1) Turn ignition switch to OFF.

- (2) Loosen throttle position sensor holding screws.

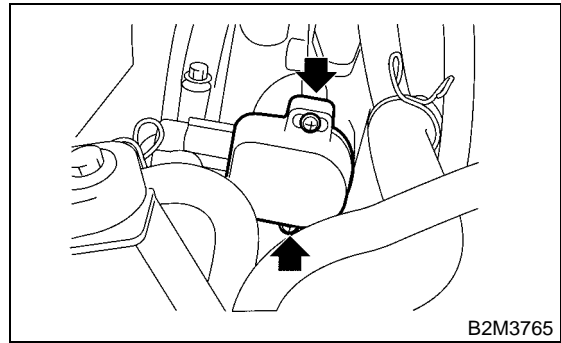

#### NOTE:

For detailed operation procedures, refer to the Subaru Select Monitor Operation Manual.

- (3) Insert the cartridge to Subaru Select Monitor.

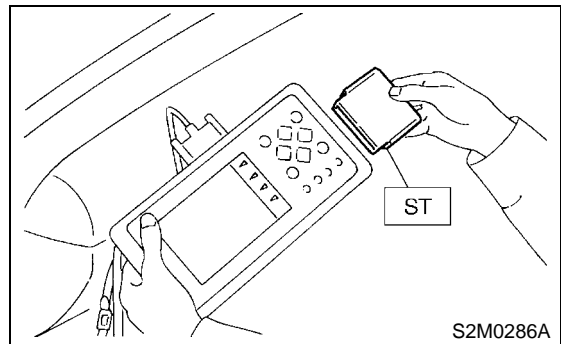

- (4) Connect Subaru Select Monitor to the data link connector.

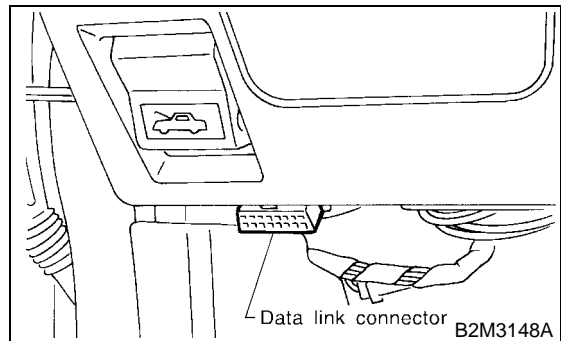

- 5) Turn ignition switch to ON, and Subaru Select Monitor switch to ON.
- 6) Select {2. Each System Check} in Main Menu.
- 7) Select {Engine Control System} in Selection Menu.
- 8) Select {1. Current Data Display & Save} in Engine Control System Diagnosis.
- 9) Select {1.12 Data Display} in Data Display Menu.
- 10) Adjust throttle position sensor to the proper position to match with the following specifications.

**Condition: Throttle fully closed**  
**Throttle opening angle 0.00%**  
**Throttle sensor voltage 0.50 V**

## THROTTLE POSITION SENSOR

FUEL INJECTION (FUEL SYSTEMS)

11) Tighten throttle position sensor holding screws.

**Tightening torque:**

**1.6 N·m (0.16 kgf·m, 1.2 ft·lb)**

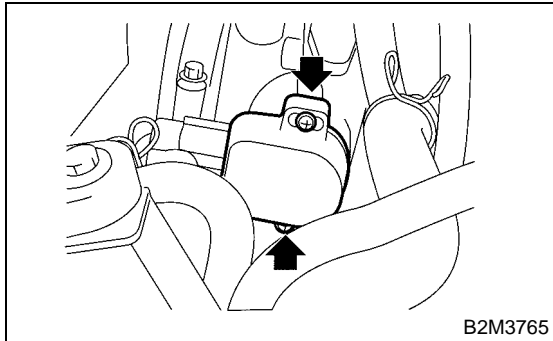

B2M3765

# INTAKE AIR TEMPERATURE AND PRESSURE SENSOR

FUEL INJECTION (FUEL SYSTEMS)

## 9. Intake Air Temperature and Pressure Sensor

### A: REMOVAL

- 1) Disconnect battery ground cable.

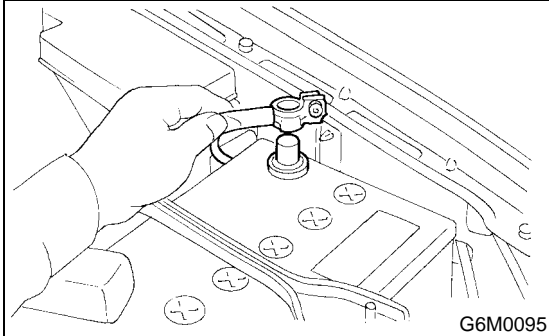

- 2) Disconnect spark plug cord from ignition coil and ignitor assembly.

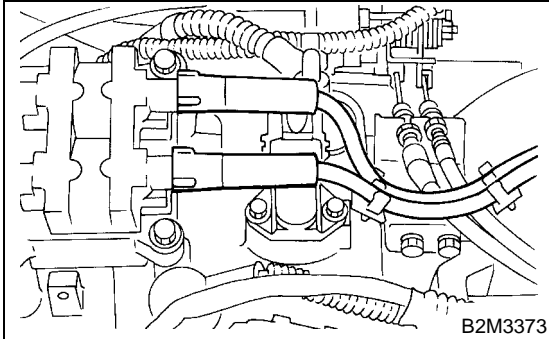

- 3) Disconnect connector from intake air temperature and pressure sensor.

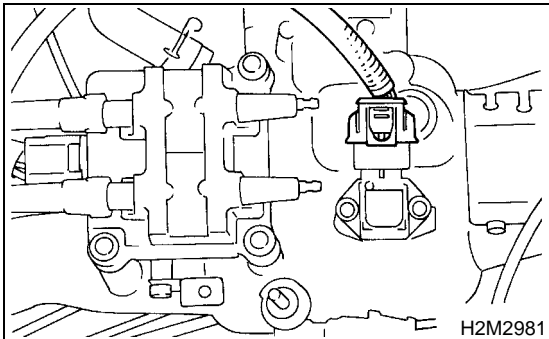

- 4) Remove intake air temperature and pressure sensor.

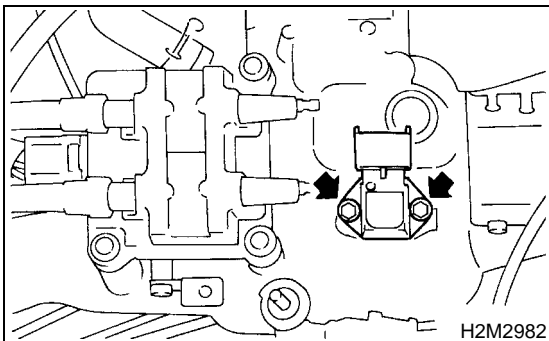

### B: INSTALLATION

Install in the reverse order of removal.

**Tightening torque:**

**3.4 N·m (0.35 kgf·m, 2.5 ft·lb)**

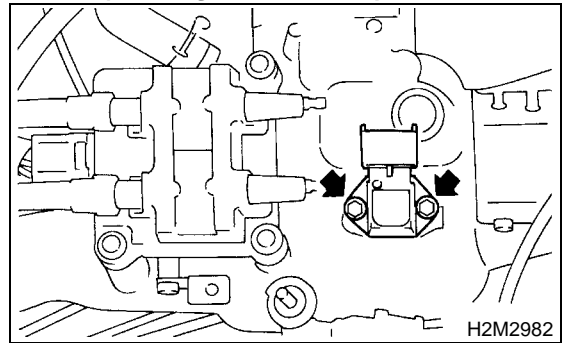

**CAUTION:**

**Replace O-ring with new one.**

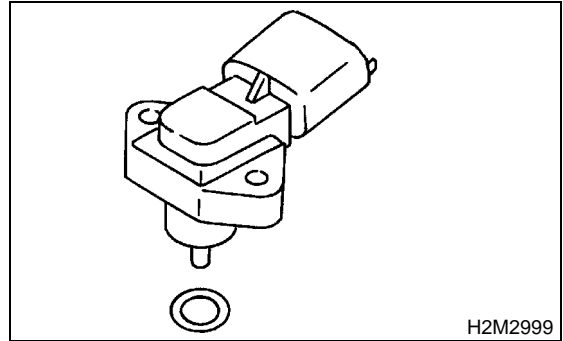

# IDLE AIR CONTROL SOLENOID VALVE

FUEL INJECTION (FUEL SYSTEMS)

## 10. Idle Air Control Solenoid Valve

### A: REMOVAL

- 1) Disconnect battery ground cable.

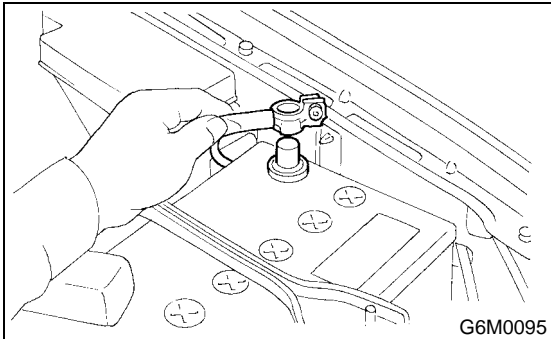

- 2) Disconnect connector from idle air control solenoid valve.

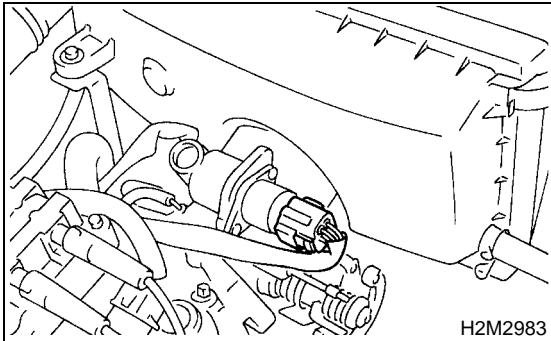

- 3) Remove idle air control solenoid valve from throttle body.

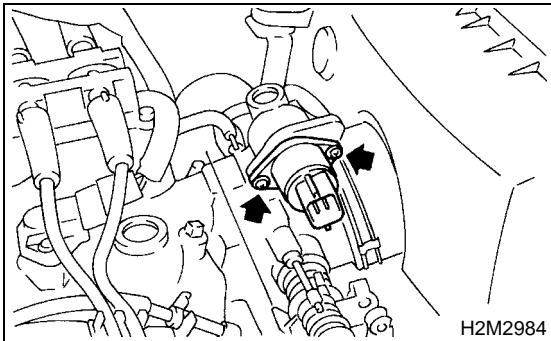

### B: INSTALLATION

Install in the reverse order of removal.

#### CAUTION:

Always use new gasket.

**Tightening torque:**

**1.6 N·m (0.16 kgf-m, 1.2 ft-lb)**

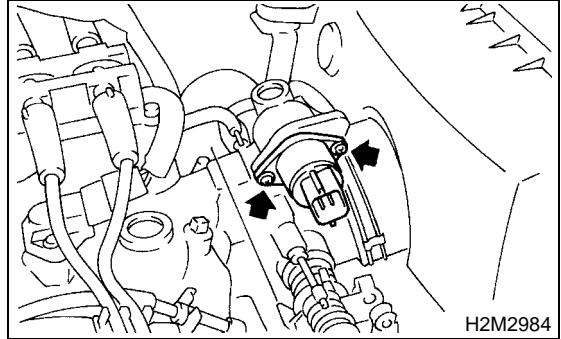

# FUEL INJECTOR

## FUEL INJECTION (FUEL SYSTEMS)

### 11. Fuel Injector

#### A: REMOVAL

##### 1. RH SIDE

- 1) Release fuel pressure.  
<Ref. to FU(SOHCw/oOBD)-47, RELEASING OF FUEL PRESSURE, OPERATION, Fuel.>
- 2) Open fuel flap lid, and remove fuel filler cap.
- 3) Disconnect battery ground cable.

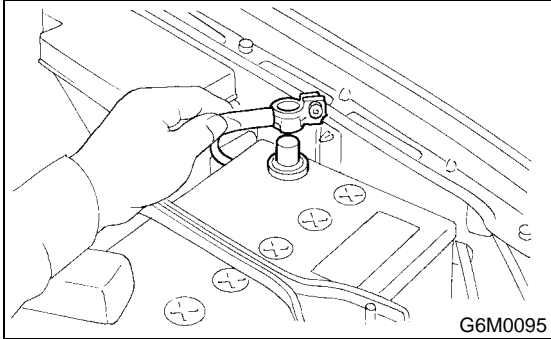

- 4) Remove resonator chamber. <Ref. to IN(SOHC)-8, REMOVAL, Resonator Chamber.>
- 5) Remove spark plug cords from spark plugs (#1 and #3 cylinders).

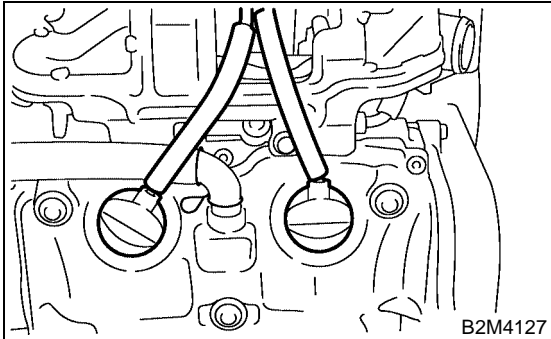

- 6) Remove power steering pump and tank from brackets.

- (1) Remove front side V-belt. <Ref. to ME(SOHC)-42, REMOVAL, V-belt.>
- (2) Remove bolts which hold power steering pipes onto intake manifold protector.

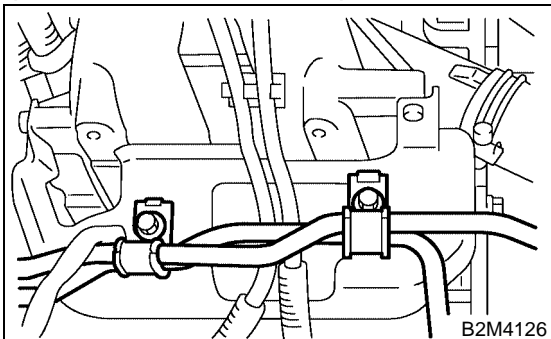

- (3) Remove bolts which install power steering pump to bracket.

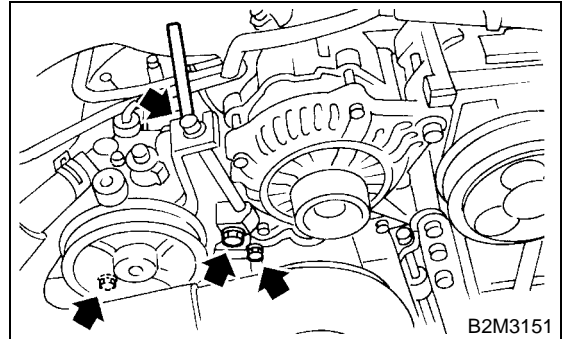

- (4) Disconnect connector from power steering pump switch.

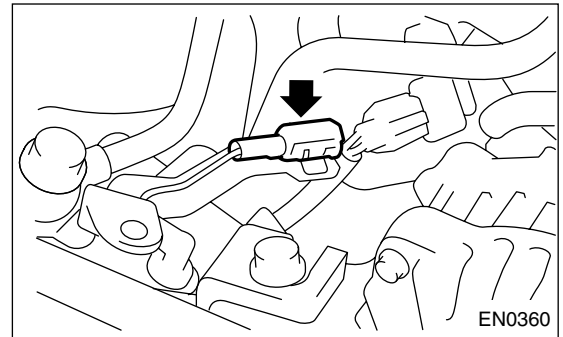

- (5) Remove power steering tank from the bracket by pulling it upwards.

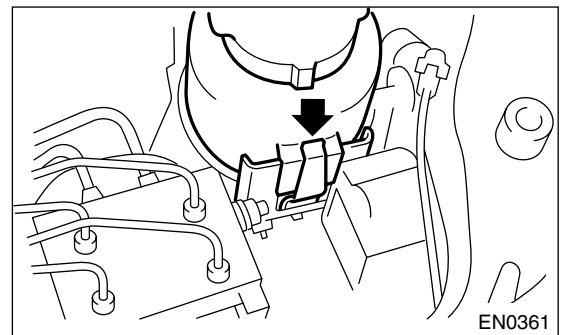

- (6) Place power steering pump and tank on the right side wheel apron.

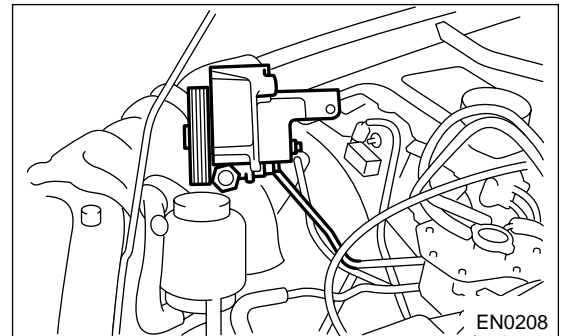

# FUEL INJECTOR

FUEL INJECTION (FUEL SYSTEMS)

7) Remove fuel pipe protector RH.

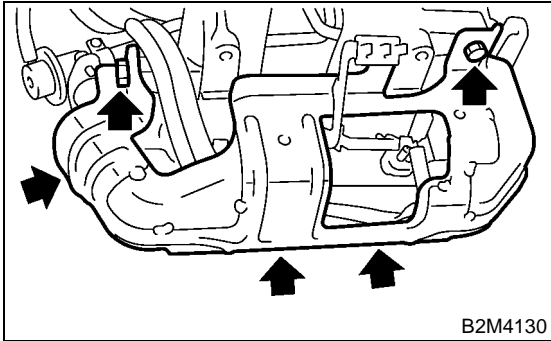

8) Disconnect connector from fuel injector.

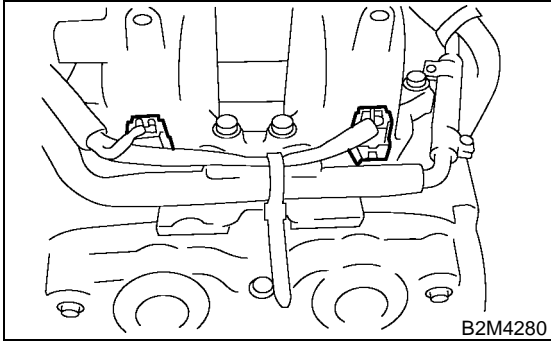

9) Remove bolts which hold injector pipe to intake manifold.

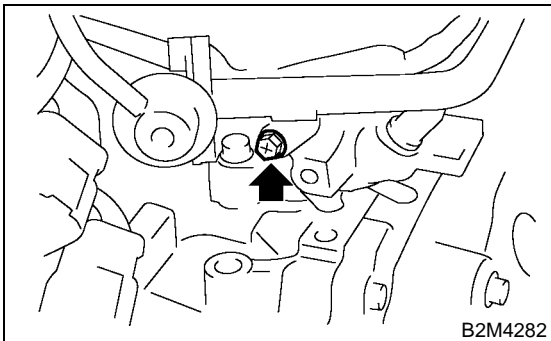
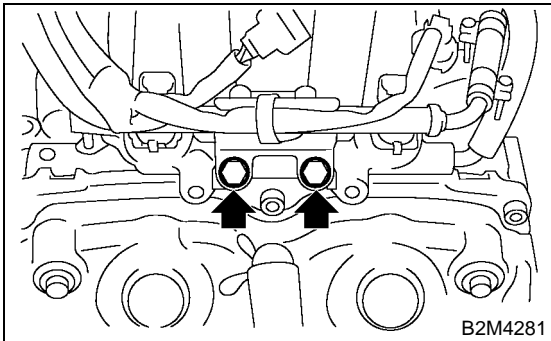

10) Remove fuel injector from intake manifold.

(1) Remove fuel injector securing clip.

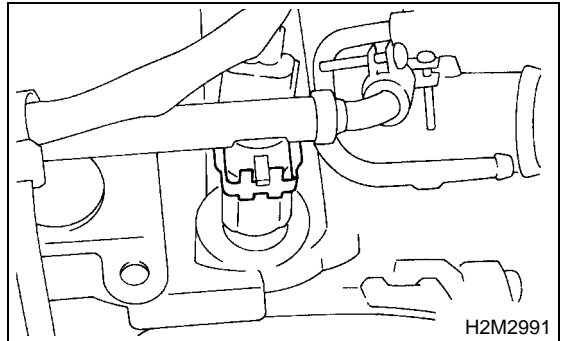

(2) Remove fuel injector while lifting up fuel injector pipe.

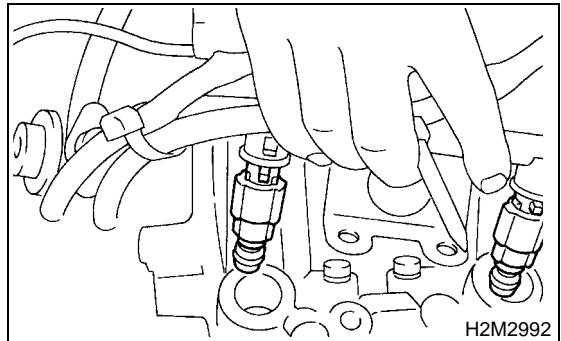

# FUEL INJECTOR

## FUEL INJECTION (FUEL SYSTEMS)

### 2. LH SIDE

- 1) Release fuel pressure. <Ref. to FU(SOHCw/oOBD)-47, RELEASING OF FUEL PRESSURE, OPERATION, Fuel.>
- 2) Open fuel flap lid, and remove fuel filler cap.
- 3) Disconnect battery ground cable.

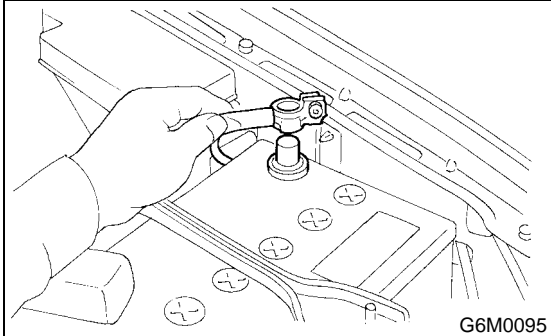

- 4) Remove two bolts which install washer tank on body.

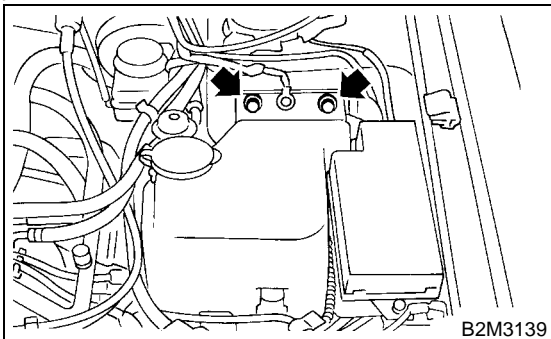

- 5) Disconnect connector from front window washer motor.
- 6) Disconnect connector from rear gate glass washer motor.

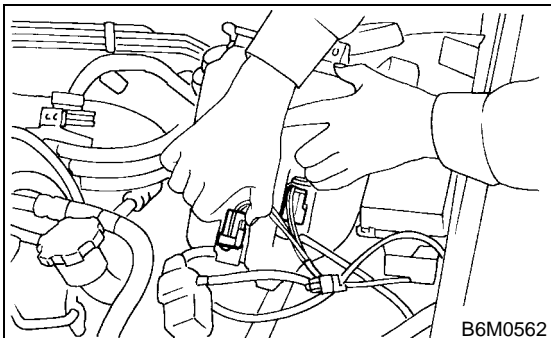

- 7) Disconnect rear window glass washer hose from washer motor, then plug connection with a suitable cap.

- 8) Move washer tank, and secure it away from working area.

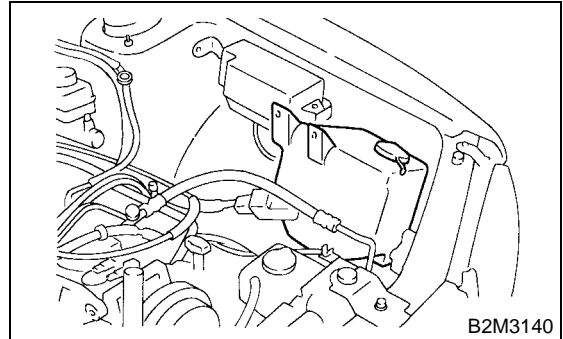

- 9) Remove spark plug cords from spark plugs (#2 and #4 cylinders).

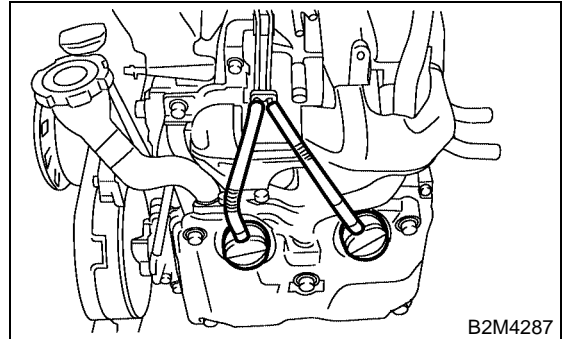

- 10) Remove fuel pipe protector LH.

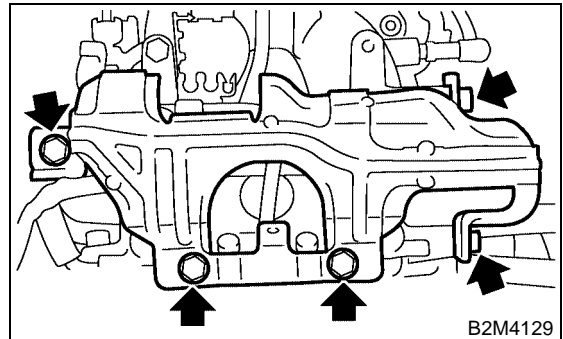

- 11) Disconnect connector from fuel injector.

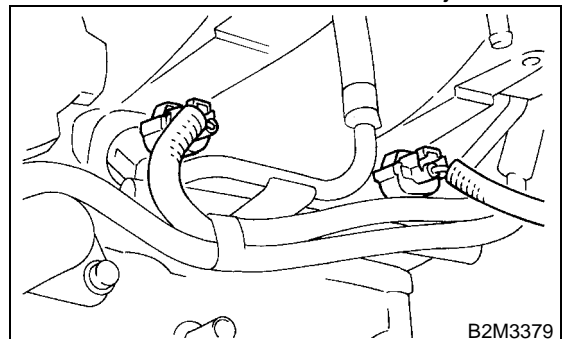

# FUEL INJECTOR

FUEL INJECTION (FUEL SYSTEMS)

12) Remove bolt which installs injector pipe to intake manifold.

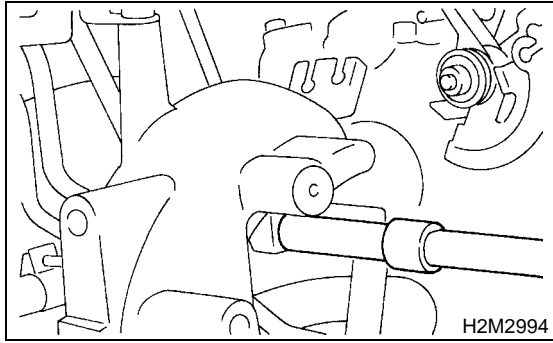

(2) Remove fuel injector while lifting up fuel injector pipe.

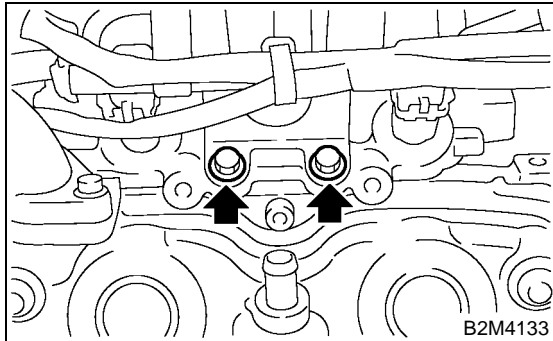
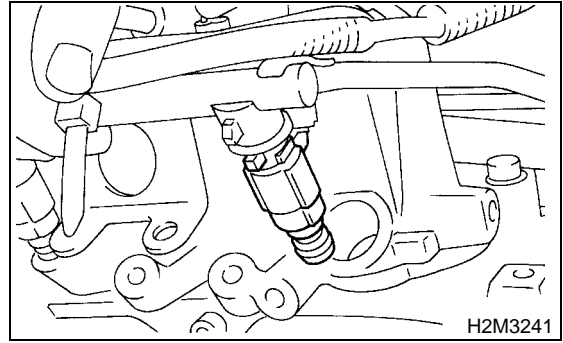

## B: INSTALLATION

### 1. RH SIDE

Install in the reverse order of removal.

#### CAUTION:

Replace O-rings with new ones.

13) Remove bolt which holds fuel pipe on the left side intake manifold.

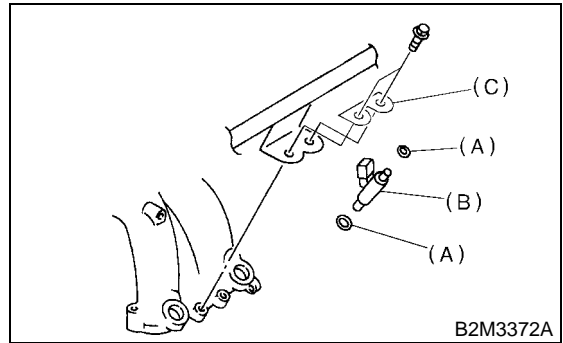
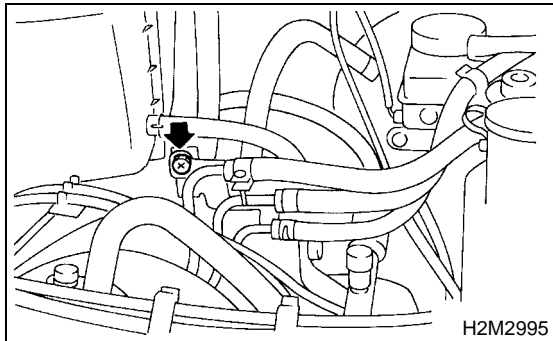

- (A) O-ring
- (B) Fuel injector
- (C) Intake manifold protector

14) Remove fuel injector from intake manifold.  
(1) Remove fuel injector securing clip.

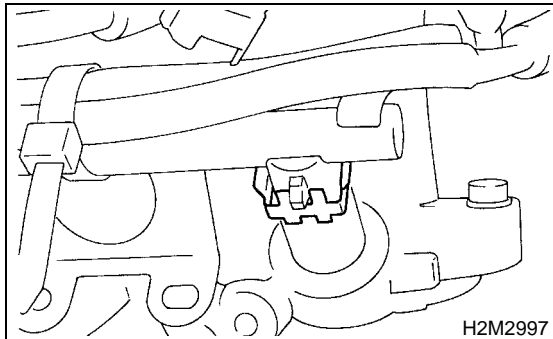

#### Tightening torque:

**5.0 N·m (0.51 kgf-m, 3.7 ft-lb)**

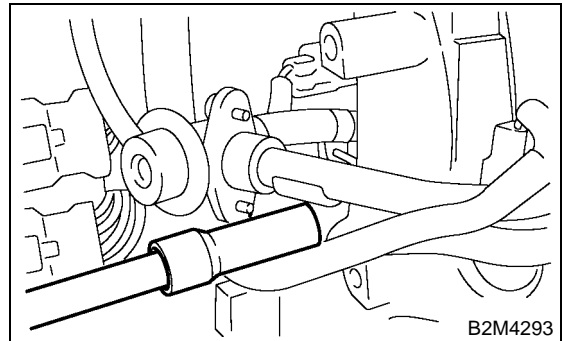



# FUEL INJECTOR

## FUEL INJECTION (FUEL SYSTEMS)

**Tightening torque:**

**19 N·m (0.19 kgf-m, 1.4 ft-lb)**

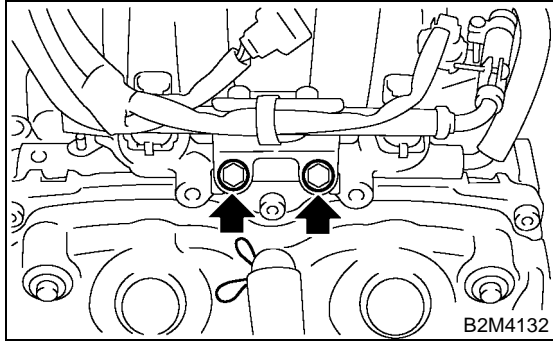

**Tightening torque:**

**19 N·m (1.9 kgf-m, 13.7 ft-lb)**

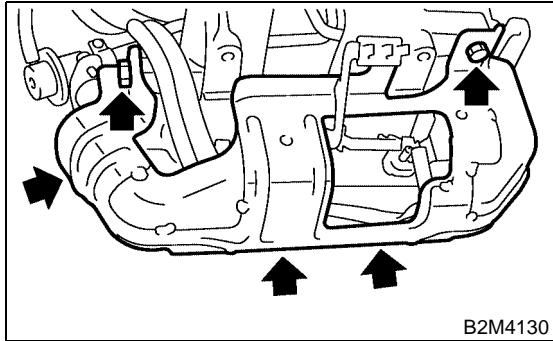

**Tightening torque:**

**32 N·m (3.3 kgf-m, 23.9 ft-lb)**

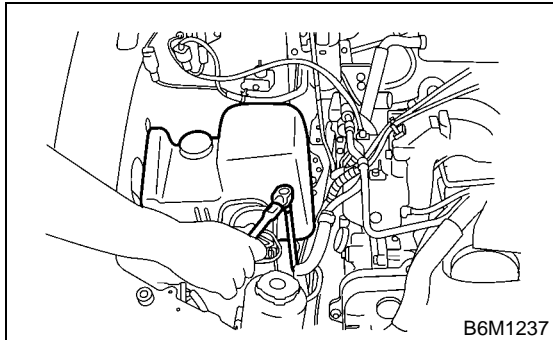

## 2. LH SIDE

Install in the reverse order of removal.

**CAUTION:**

Replace O-rings with new ones.

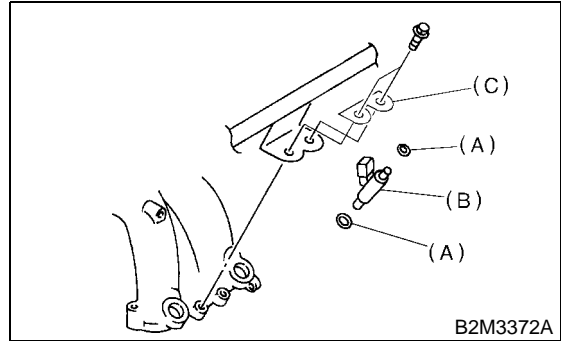

- (A) O-ring
- (B) Fuel injector
- (C) Intake manifold protector

**Tightening torque:**

**5.0 N·m (0.51 kgf-m, 3.7 ft-lb)**

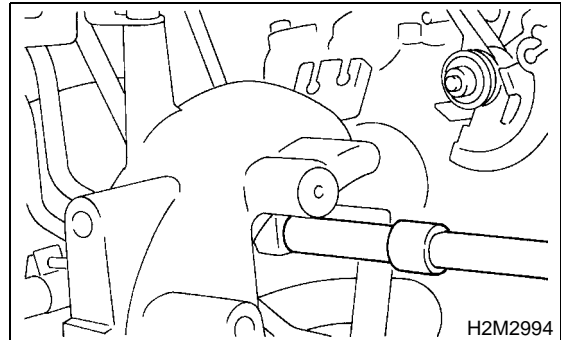

**Tightening torque:**

**5.0 N·m (0.51 kgf-m, 3.7 ft-lb)**

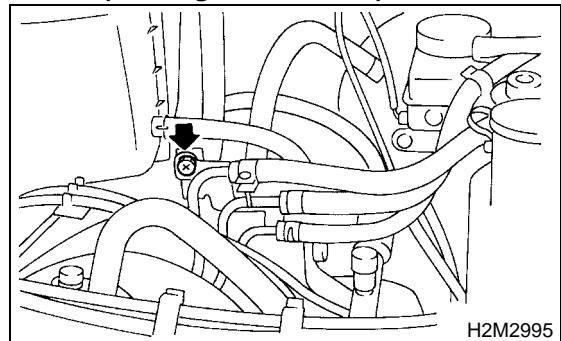

**Tightening torque:**

**19 N·m (1.9 kgf-m, 13.7 ft-lb)**

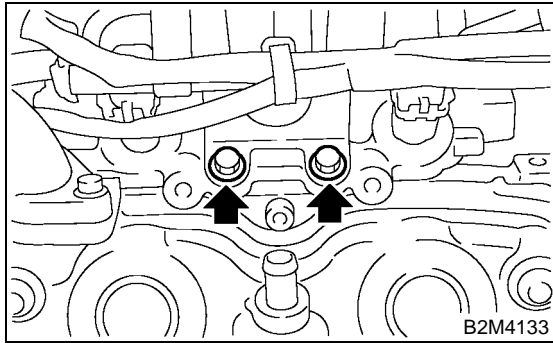

**Tightening torque:**

**19 N·m (1.9 kgf-m, 13.7 ft-lb)**

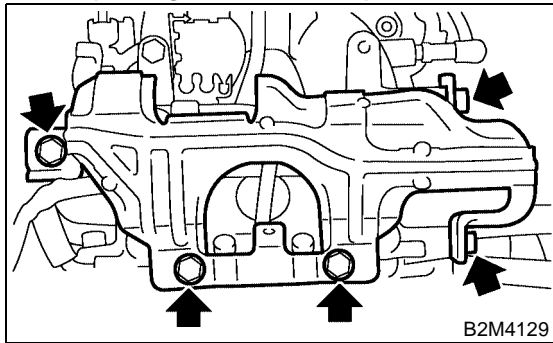

# OXYGEN SENSOR

FUEL INJECTION (FUEL SYSTEMS)

## 12. Oxygen Sensor

### A: REMOVAL

- 1) Disconnect battery ground cable.

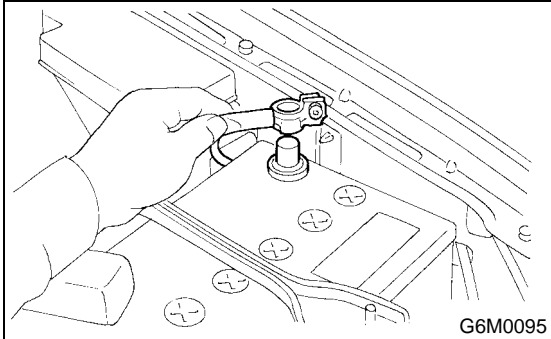

- 2) Disconnect connector from oxygen sensor.

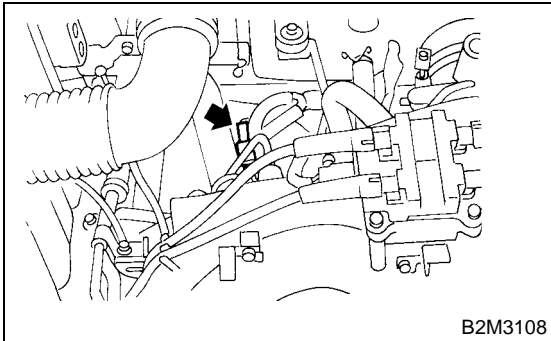

- 3) Lift-up the vehicle.
- 4) Apply SUBARU CRC or its equivalent to threaded portion of oxygen sensor, and leave it for one minute or more.

**SUBARU CRC (Part No. 004301003)**

- 5) Remove oxygen sensor.

### CAUTION:

**When removing the oxygen sensor, wait until exhaust pipe cools, otherwise it will damage exhaust pipe.**

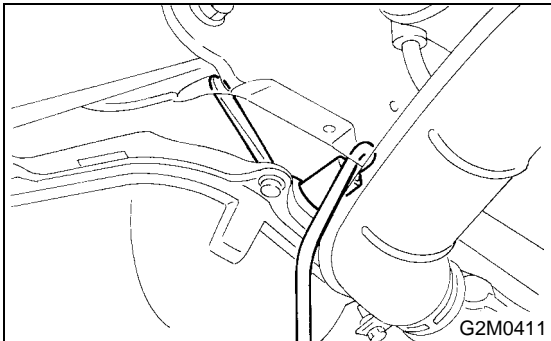

### B: INSTALLATION

- 1) Before installing oxygen sensor, apply anti-seize compound only to threaded portion of oxygen sensor to make the next removal easier.

**Anti-seize compound:  
SS-30 by JET LUBE**

### CAUTION:

**Never apply anti-seize compound to protector of oxygen sensor.**

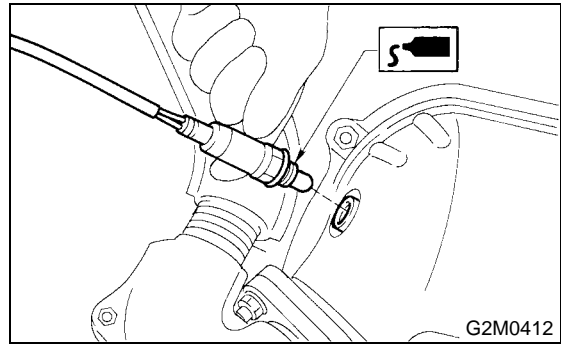

- 2) Install oxygen sensor.

### Tightening torque:

**21 N·m (2.1 kgf-m, 15.2 ft-lb)**

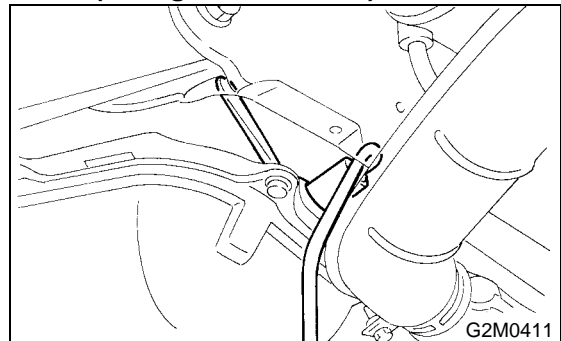

- 3) Lower the vehicle.
- 4) Connect connector of oxygen sensor.

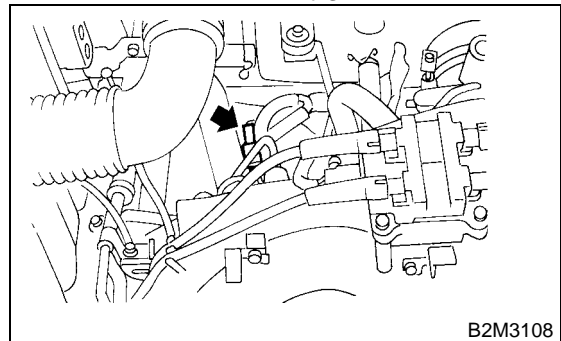

5) Connect battery ground cable.

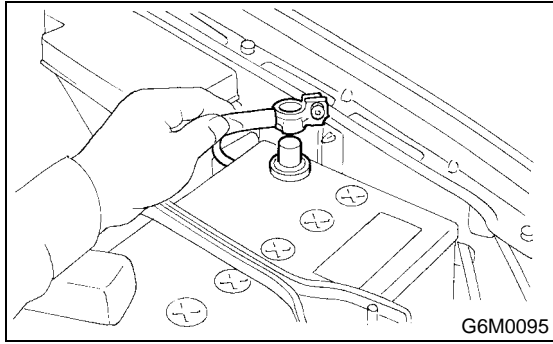

# ENGINE CONTROL MODULE

## FUEL INJECTION (FUEL SYSTEMS)

### 13.Engine Control Module

#### A: REMOVAL

- 1) Disconnect battery ground cable.

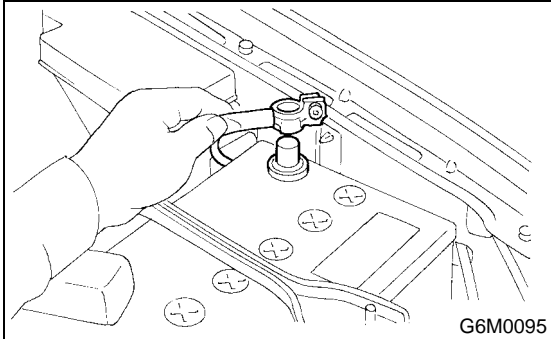

- 2) Remove lower inner trim of passenger side.  
<Ref. to EI-29, REMOVAL, Lower Inner Trim.>
- 3) Detach floor mat of front passenger seat.
- 4) Remove protect cover.

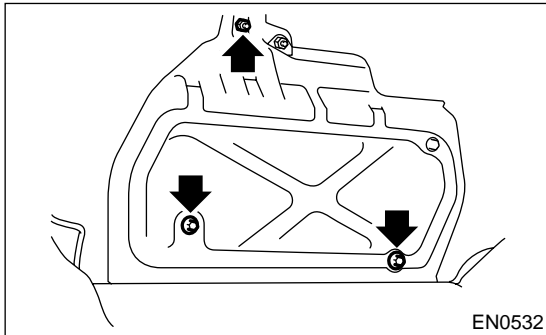

- 5) Remove nuts (A) which hold ECM to bracket.
- 6) Remove clip (B) from bracket.

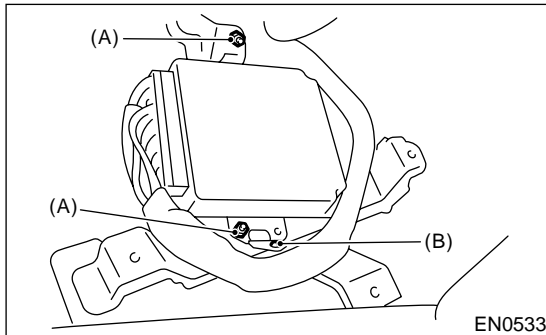

- 7) Disconnect ECM connectors and take out ECM.

#### B: INSTALLATION

Install in the reverse order of removal.

#### CAUTION:

When replacing ECM, be careful not to use the wrong spec. ECM to avoid any damage to the fuel injection system.

## 14.Main Relay

### A: REMOVAL

- 1) Disconnect battery ground cable.

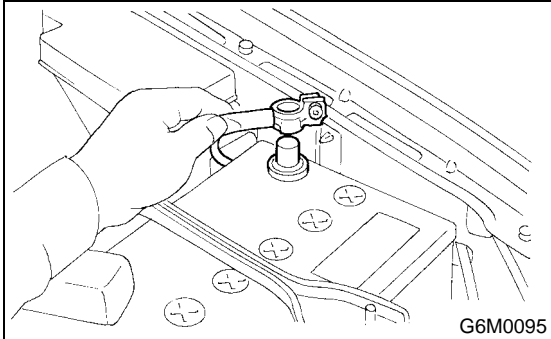

- 2) Remove passenger's side front side sill cover.
- 3) Remove bolt which holds main relay bracket on body.
- 4) Disconnect connectors from main relay.

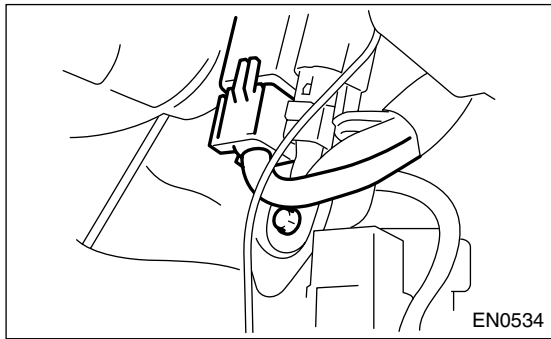

### B: INSTALLATION

Install in the reverse order of removal.

### 15. Fuel Pump Relay

#### A: REMOVAL

- 1) Disconnect battery ground cable.

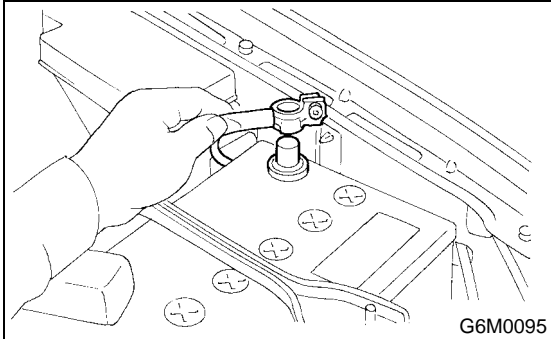

- 2) Remove passenger's side front side sill cover.
- 3) Remove bolt which holds fuel pump relay bracket on body.
- 4) Disconnect connector from fuel pump.

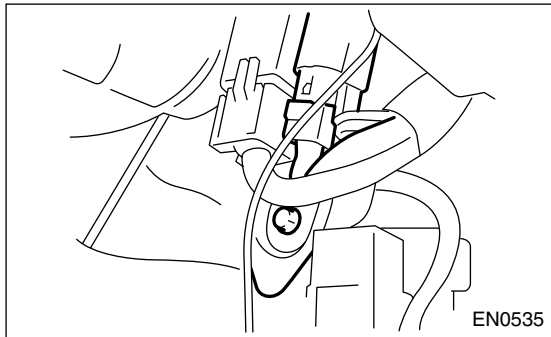

- 5) Remove fuel pump relay from mounting bracket.

#### B: INSTALLATION

Install in the reverse order of removal.

### 16. Fuel

#### A: OPERATION

##### 1. RELEASING OF FUEL PRESSURE

**WARNING:**

- Place “NO FIRE” signs near the working area.
- Be careful not to spill fuel on the floor.

- 1) Disconnect connector from fuel pump relay.



- 2) Start the engine and run it until it stalls.
- 3) After the engine stalls, crank it for five more seconds.
- 4) Turn ignition switch to OFF.

##### 2. DRAINING FUEL

**WARNING:**

- Place “NO FIRE” signs near the working area.
- Be careful not to spill fuel on the floor.

- 1) Set vehicle on the lift.
- 2) Disconnect battery ground cable.

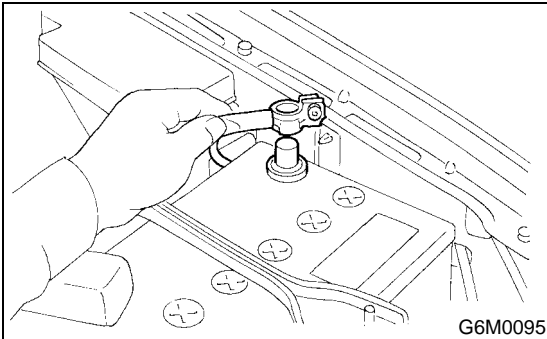

- 3) Lift-up the vehicle.
- 4) Drain fuel from fuel tank.  
Set a container under the vehicle and remove drain plug from fuel tank.

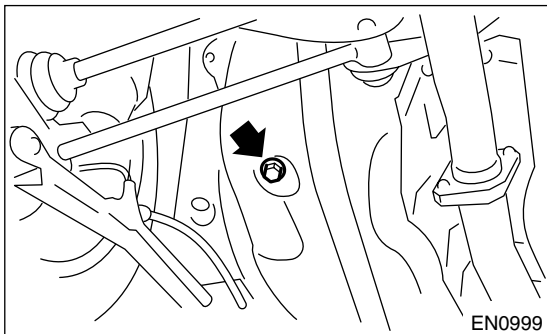

- 5) Tighten fuel drain plug.

**Tightening torque:**

**26 N·m (2.65 kgf·m, 19.2 ft·lb)**

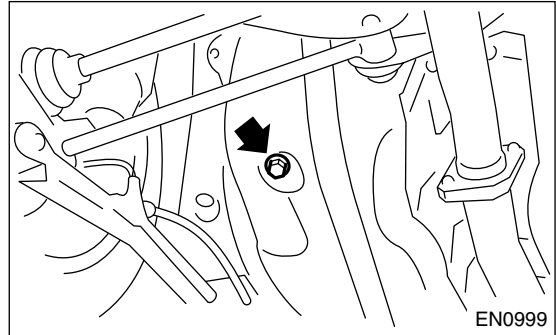



# FUEL TANK

## FUEL INJECTION (FUEL SYSTEMS)

### 17. Fuel Tank

#### A: REMOVAL

##### WARNING:

- Place “NO FIRE” signs near the working area.
- Be careful not to spill fuel on the floor.

- 1) Set vehicle on the lift.
- 2) Release fuel pressure. <Ref. to FU(SOHCw/oOBD)-47, RELEASING OF FUEL PRESSURE, OPERATION, Fuel.>
- 3) Drain fuel from fuel tank. <Ref. to FU(SOHCw/oOBD)-47, DRAINING FUEL, OPERATION, Fuel.>
- 4) Remove rear seat.
- 5) Disconnect connector (A) of fuel tank cord to rear harness.
- 6) Push grommet (B) which holds fuel tank cord on floor panel into under the body.

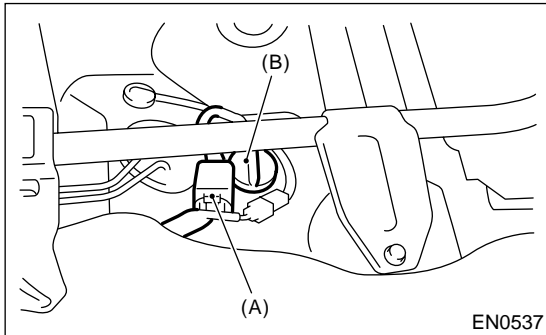

- 7) Remove rear crossmember. <Ref. to RS-22, REMOVAL, Rear Crossmember.>
- 8) Disconnect two-way valve hose (A) from two-way valve and disconnect canister hose (B) from canister.

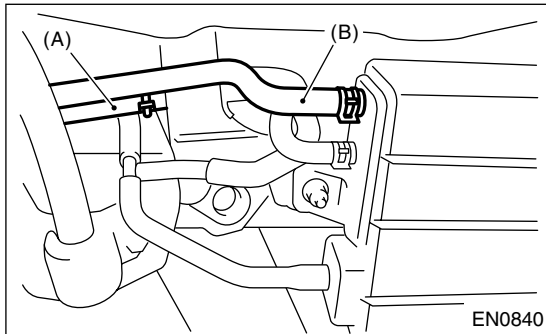

- 9) Loosen clamp and disconnect fuel filler hose (A) and air vent hose (B) from fuel filler pipe.

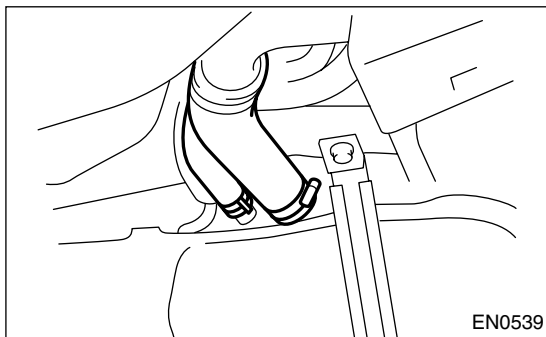

- 10) Move clips, and disconnect quick connector. <Ref. to FU(SOHCw/oOBD)-60, REMOVAL, Fuel Delivery, Return and Evaporation Lines.>
- 11) Disconnect fuel hoses.

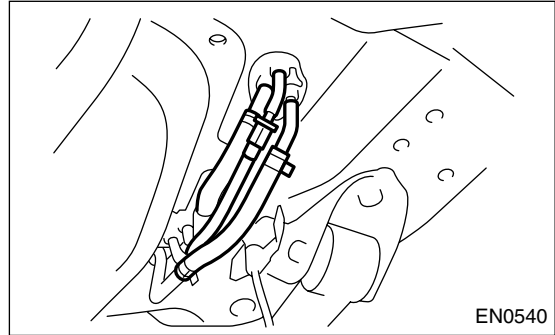

- 12) Support fuel tank with transmission jack, remove bolts from bands and dismount fuel tank from the vehicle.

##### WARNING:

A helper is required to perform this work.

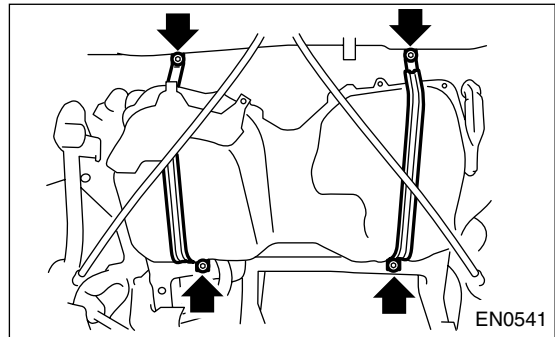

#### B: INSTALLATION

- 1) Support fuel tank with transmission jack and push fuel tank harness into access hole with grommet.
- 2) Set fuel tank and temporarily tighten bolts of fuel tank bands.

##### WARNING:

A helper is required to perform this work.

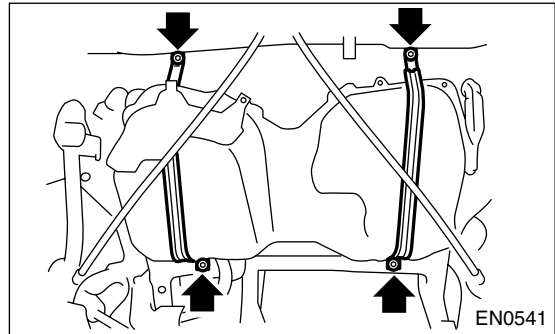

# FUEL TANK

FUEL INJECTION (FUEL SYSTEMS)

- 3) Connect two-way valve hose (A) to two-way valve and connect canister hose (B) to canister.

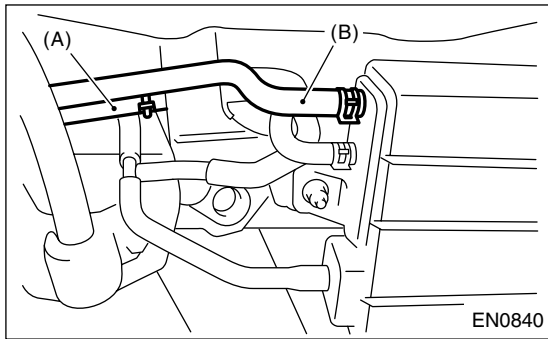

- 4) Connect fuel filler hose (A) and air vent hose (B).

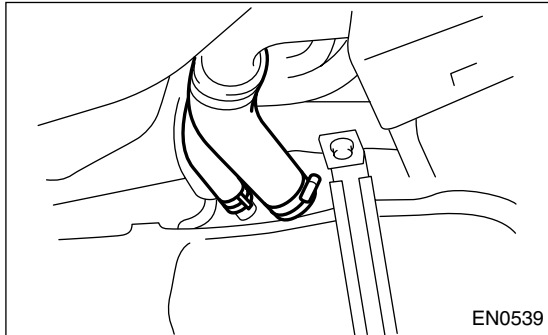

- 5) Connect fuel hoses, and hold them with clips and quick connector. <Ref. to FU(SOHCw/oOBD)-61, INSTALLATION, Fuel Delivery, Return and Evaporation Lines.>

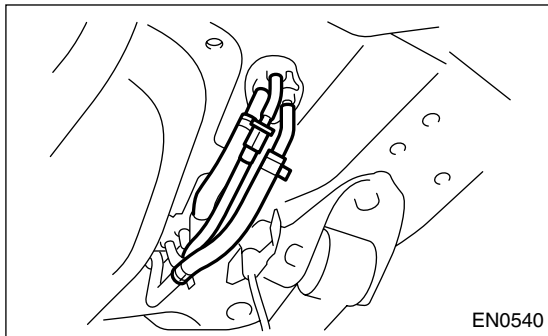

- 6) Tighten band mounting bolts.

**Tightening torque:**

**33 N·m (3.4 kgf·m, 25 ft·lb)**

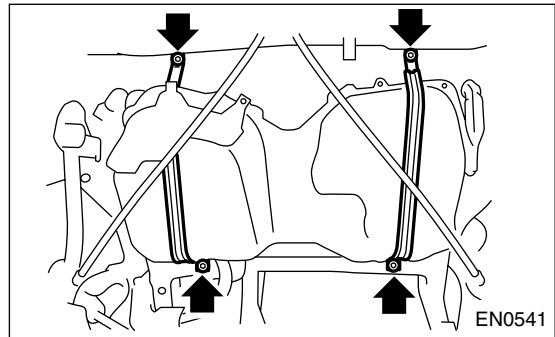

- 7) Install rear crossmember. <Ref. to RS-23, INSTALLATION, Rear Crossmember.>

- 8) Connect connectors to fuel tank cord and plug service hole with grommet.

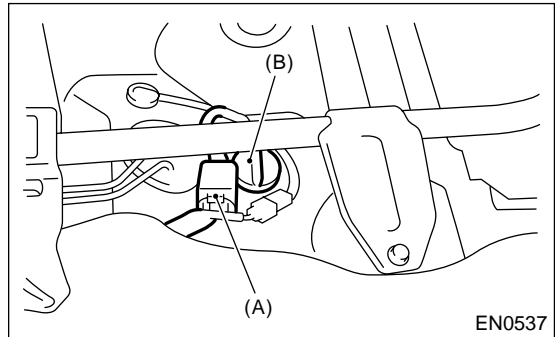

- 9) Set rear seat and floor mat.

- 10) Connect connector to fuel pump relay.

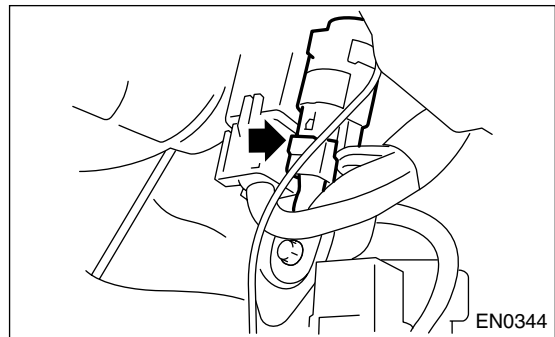

## C: INSPECTION

- 1) Make sure there are no cracks, holes, or other damage on the fuel tank.
- 2) Make sure that the fuel hoses and fuel pipes are not cracked and that connections are tight.

# FUEL FILLER PIPE

FUEL INJECTION (FUEL SYSTEMS)

## 18. Fuel Filler Pipe

### A: REMOVAL

#### WARNING:

- Place "NO FIRE" signs near the working area.
- Be careful not to spill fuel on the floor.

- 1) Release fuel pressure. <Ref. to FU(SOHCw/oOBD)-47, RELEASING OF FUEL PRESSURE, OPERATION, Fuel.>
- 2) Open fuel filler flap lid and remove filler cap.
- 3) Disconnect battery ground cable.

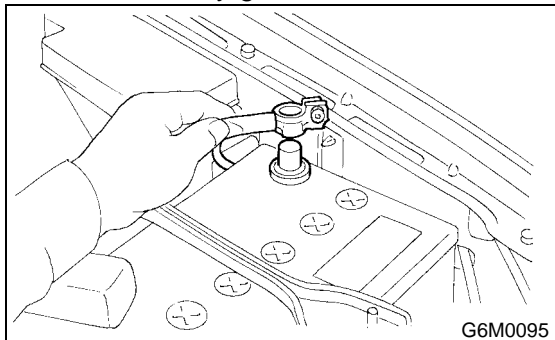

- 4) Remove screws holding packing in place.

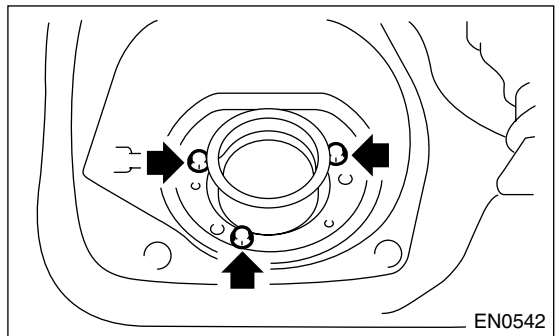

- 5) Lift-up the vehicle.
- 6) Remove rear right side wheel nuts.
- 7) Remove rear right side wheel.

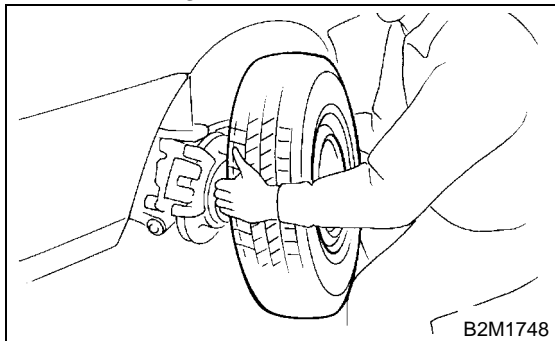

- 8) Drain fuel from fuel tank. Set a container under the vehicle and remove drain plug from fuel tank.

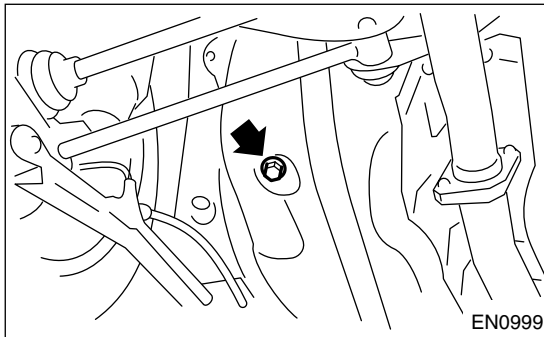

- 9) Tighten fuel drain plug and then install front right side tank cover.

#### Tightening torque:

$26 \pm 7 \text{ N}\cdot\text{m}$  ( $2.65 \pm 0.7 \text{ kg}\cdot\text{m}$ ,  $19.2 \pm 5.1 \text{ ft}\cdot\text{lb}$ )

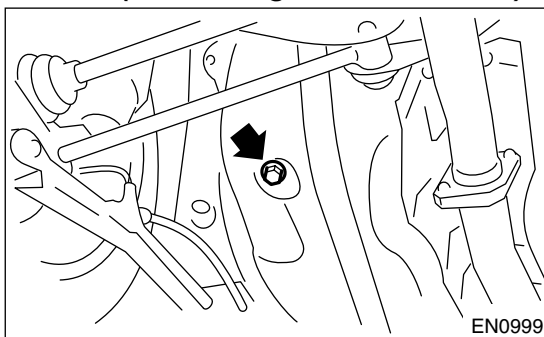

- 10) Remove fuel filler pipe protector.

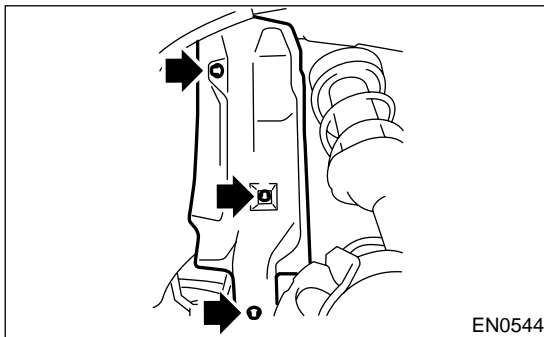

- 11) Separate evaporation hoses from clip of fuel filler pipe.

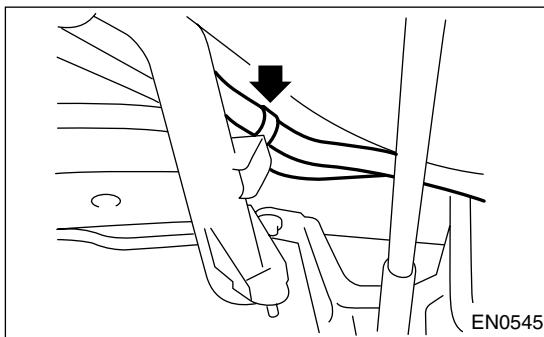

# FUEL FILLER PIPE

FUEL INJECTION (FUEL SYSTEMS)

12) Disconnect air vent hose from fuel filler pipe.

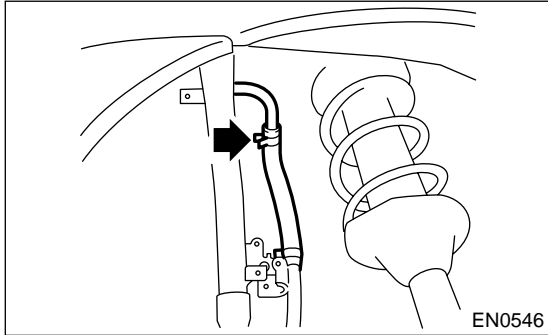

13) Remove bolts which hold fuel filler pipe bracket on body.

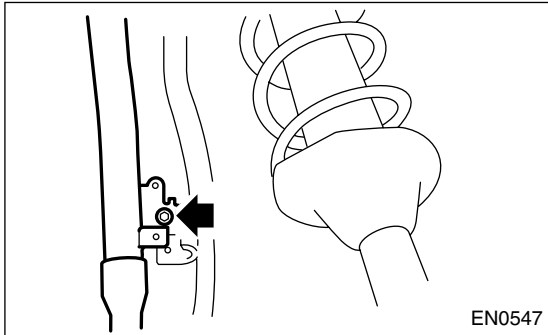

14) Loosen clamp and separate fuel filler hose (A) from fuel filler pipe.

15) Move clip and separate air vent hose (B).

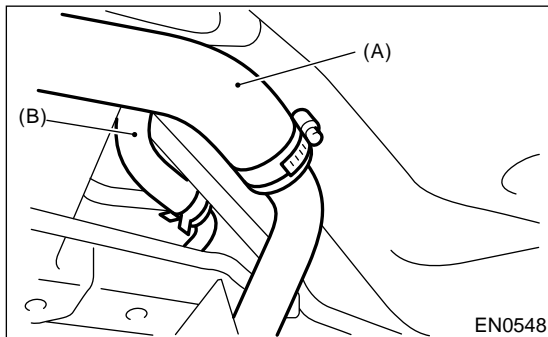

16) Remove fuel filler pipe to under side of the vehicle.

17) Remove air vent pipe together with clip from body.

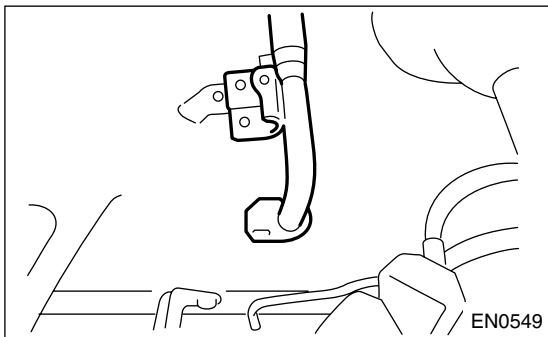

## B: INSTALLATION

1) Hold fuel filler flap open.

2) Set fuel saucer (A) with rubber packing (C) and insert fuel filler pipe into hole from the inner side of apron.

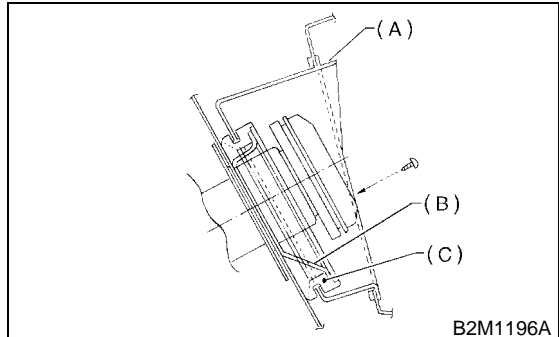

3) Align holes in fuel filler pipe neck and set cup (B), and tighten screws.

### NOTE:

If edges of rubber packing are folded toward the inside, straighten it with a screwdriver.

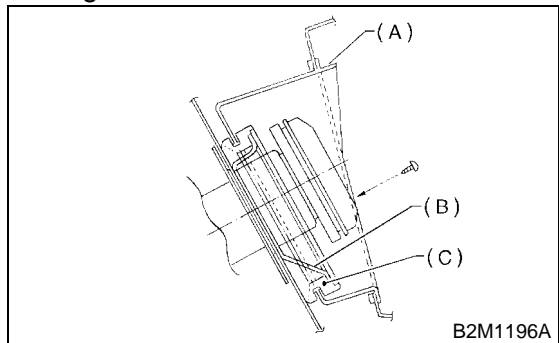

4) Install air vent pipe.

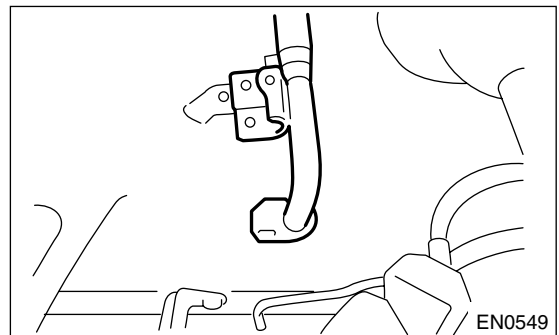

5) Connect air vent hose to fuel filler pipe.

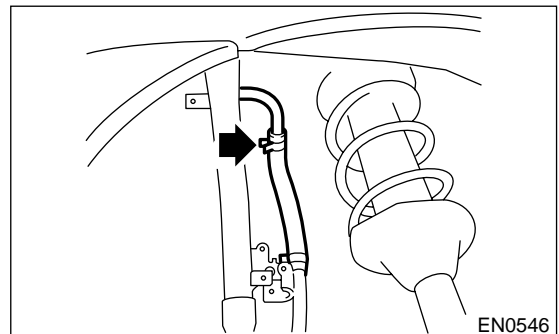

# FUEL FILLER PIPE

## FUEL INJECTION (FUEL SYSTEMS)

6) Insert fuel filler hose (A) approximately 35 to 40 mm (1.38 to 1.57 in) over the lower end of fuel filler pipe and tighten clamp.

**CAUTION:**

Do not allow clips to touch air vent hose (B) and rear suspension crossmember.

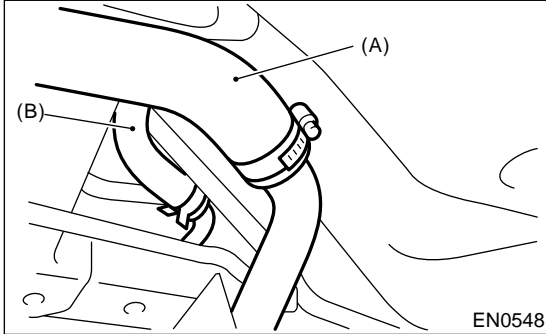

7) Insert air vent hose approximately 25 to 30 mm (0.98 to 1.18 in) into the lower end of air vent pipe and hold clip.

**$L = 27.5 \pm 2.5 \text{ mm (1.083 \pm 0.098 in)}$**

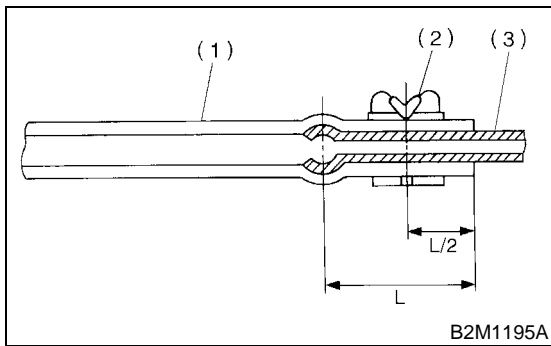

- (1) Hose
- (2) Clip
- (3) Pipe

8) Tighten bolt which holds fuel filler pipe bracket on body.

**Tightening torque:**

**$7.5 \text{ N}\cdot\text{m (0.75 kgf}\cdot\text{m, 5.4 ft}\cdot\text{lb)}$**

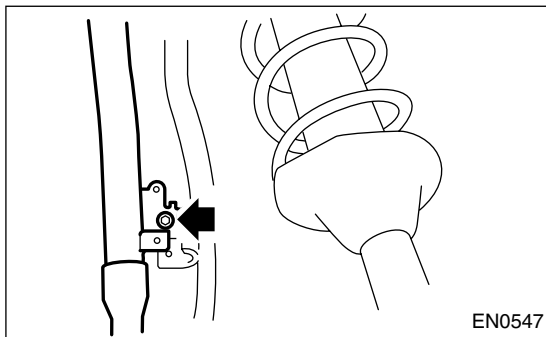

9) Tighten bolts which hold evaporation hoses onto clip of fuel filler pipe.

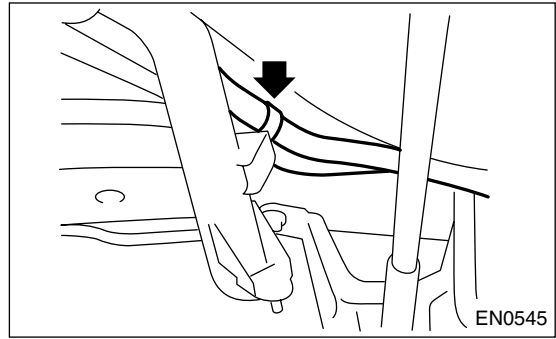

10) Install fuel filler pipe protector.

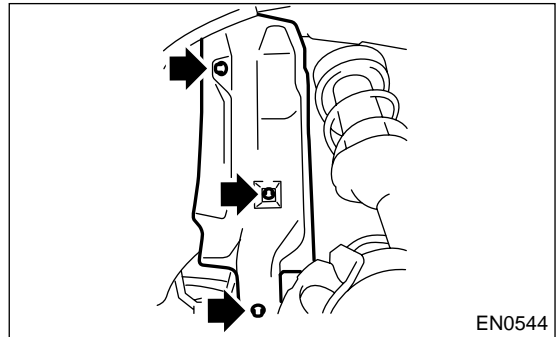

11) Install rear right wheel.

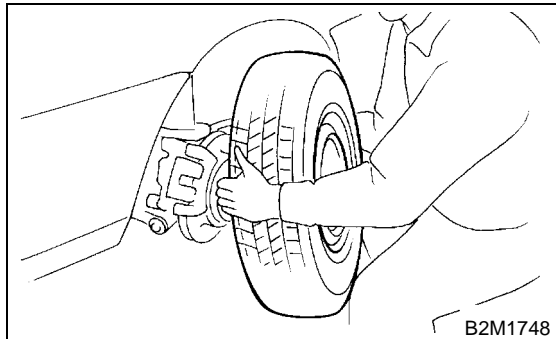

12) Lower the vehicle.

13) Tighten wheel nuts.

14) Connect connector to fuel pump relay.

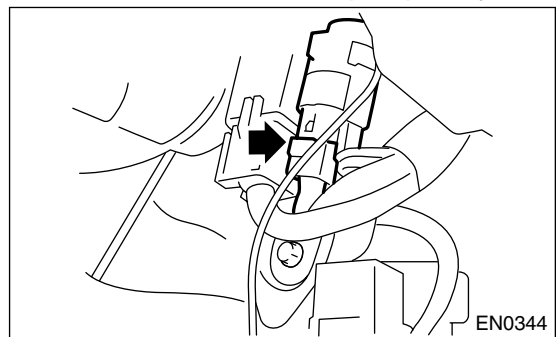

15) Connect battery ground terminal.

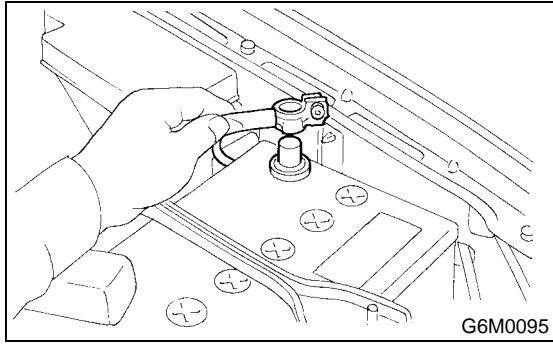

# FUEL PUMP

FUEL INJECTION (FUEL SYSTEMS)

## 19. Fuel Pump

### A: REMOVAL

#### WARNING:

- Place “NO FIRE” signs near the working area.
- Be careful not to spill fuel on the floor.

#### NOTE:

Fuel pump assembly consists of fuel pump and fuel level sensor.

- 1) Release fuel pressure. <Ref. to FU(SOHCw/oOBD)-47, RELEASING OF FUEL PRESSURE, OPERATION, Fuel.>
- 2) Open fuel filler flap lid and remove fuel filler cap.
- 3) Disconnect battery ground cable.

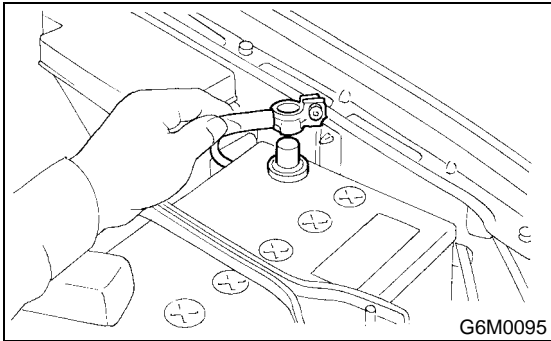

- 4) Lift-up the vehicle.
- 5) Drain fuel from fuel tank. Set a container under the vehicle and remove drain plug from fuel tank.

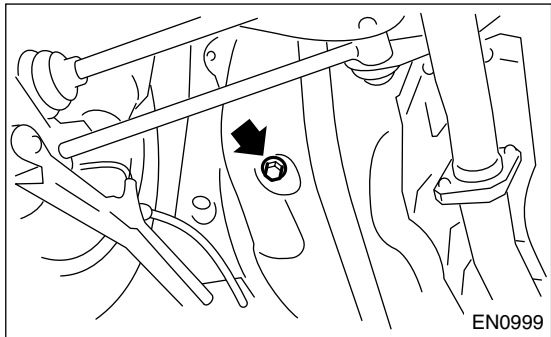

- 6) Tighten fuel drain plug.

#### Tightening torque:

**26 N·m (2.65 kgf·m, 19.2 ft·lb)**

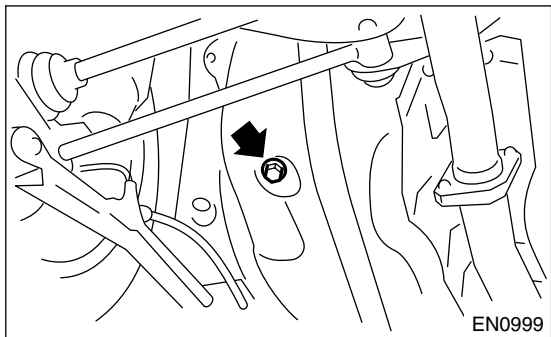

- 7) Raise rear seat and turn floor mat up.

- 8) Remove access hole lid.

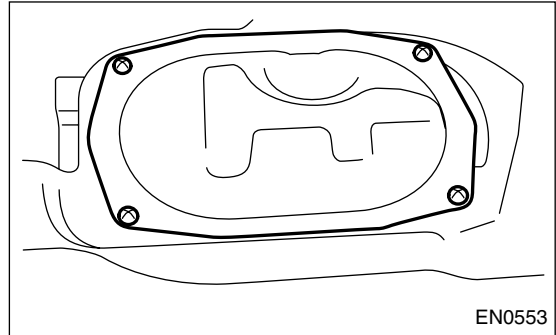

- 9) Disconnect connector from fuel pump.

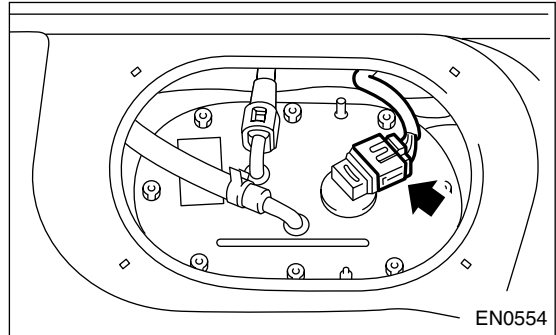

- 10) Disconnect quick connector and then disconnect fuel delivery hose (A). <Ref. to FU(SOHCw/oOBD)-60, REMOVAL, Fuel Delivery, Return and Evaporation Lines.>

- 11) Move clip and then disconnect fuel return hose (B).

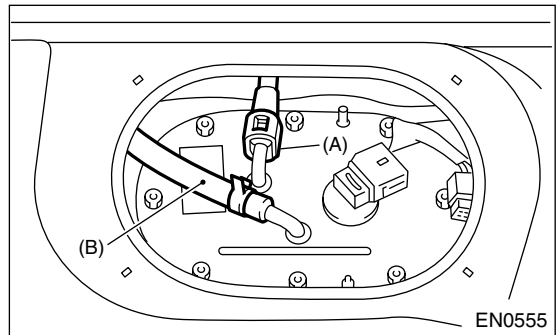

- 12) Remove nuts which install fuel pump assembly onto fuel tank.

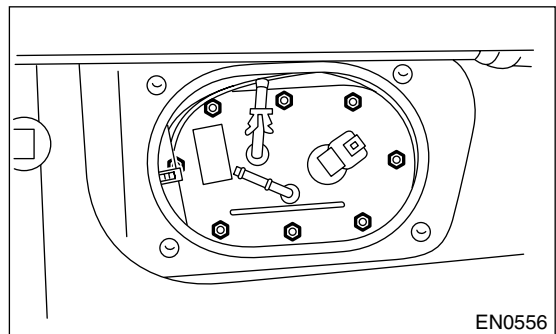

- 13) Take off fuel pump assembly from fuel tank.

## B: INSTALLATION

Install in the reverse order of removal. Do the following:

- (1) Always use new gaskets.
- (2) Ensure sealing portion is free from fuel or foreign particles before installation.
- (3) Tighten nuts in alphabetical sequence shown in figure to specified torque.

**Tightening torque:**

**5.9 N·m (0.6 kgf·m, 4.3 ft·lb)**

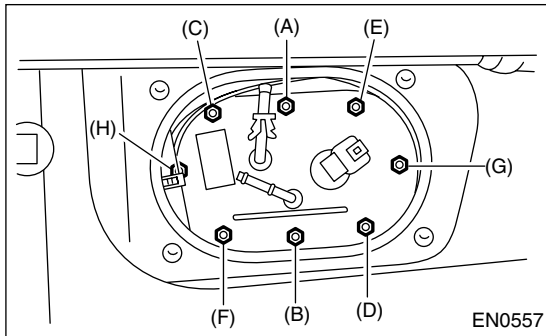

## C: INSPECTION

Connect lead harness to connector terminal of fuel pump and apply battery power supply to check whether the pump operate.

**WARNING:**

- Wipe off the fuel completely.
- Keep battery as far apart from fuel pump as possible.
- Be sure to turn the battery supply ON and OFF on the battery side.
- Do not run fuel pump for a long time under non-load condition.

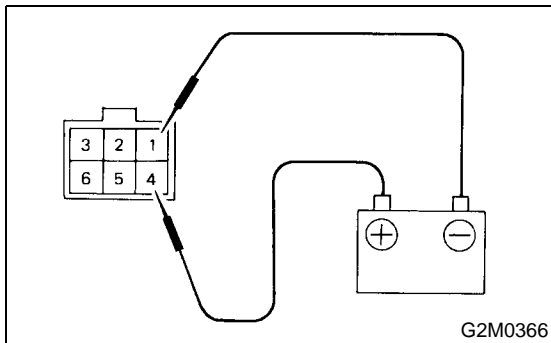



# FUEL LEVEL SENSOR

FUEL INJECTION (FUEL SYSTEMS)

## 20. Fuel Level Sensor

### A: REMOVAL

#### WARNING:

- Place “NO FIRE” signs near the working area.
- Be careful not to spill fuel on the floor.

#### NOTE:

Fuel level sensor is built in fuel pump assembly.

1) Remove fuel pump assembly. <Ref. to FU(SOHCw/oOBD)-54, REMOVAL, Fuel Pump.>

2) Disconnect connector from fuel pump bracket.

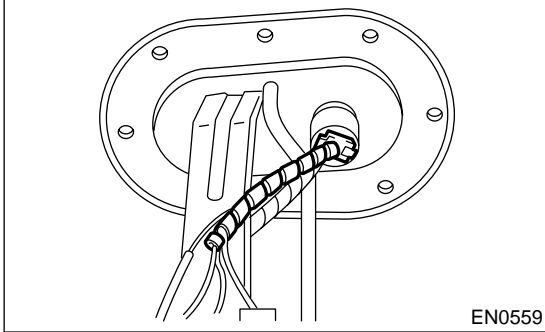

3) Remove bolt which installs fuel level sensor on mounting bracket.

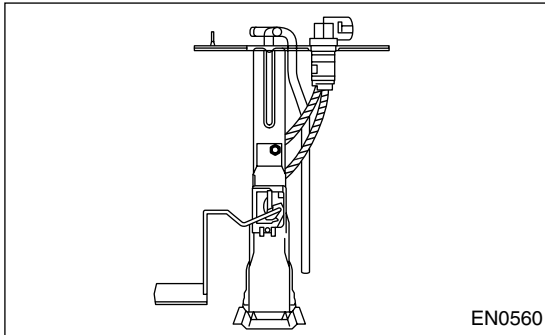

### B: INSTALLATION

Install in the reverse order of removal.

## 21. Fuel Filter

### A: REMOVAL

**WARNING:**

- Place “NO FIRE” signs near the working area.
- Be careful not to spill fuel on the floor.

- 1) Release fuel pressure. <Ref. to FU(SOHCw/oOBD)-47, RELEASING OF FUEL PRESSURE, OPERATION, Fuel.>
- 2) Disconnect fuel delivery hoses from fuel filter.

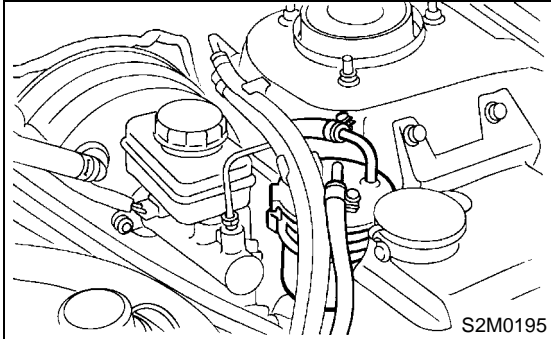

- 3) Remove filter from holder.

### B: INSTALLATION

**CAUTION:**

- If fuel hoses are damaged at the connecting portion, replace it with a new one.
- If clamps are badly damaged, replace with new ones.

- 1) Install in the reverse order of removal.
- 2) Tighten hose clamp screws.

**Tightening torque:**

**12.5 N·m (1.27 kgf-m, 9.22 ft-lb)**

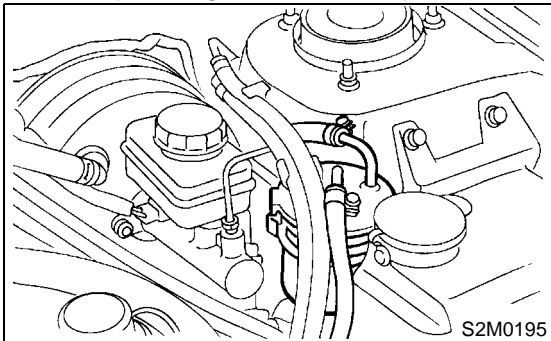

### C: INSPECTION

- 1) Check the inside of fuel filter for dirt and water sediment.
- 2) If it is clogged, or if replacement interval has been reached, replace it.
- 3) If water is found in it, shake and expel the water from inlet port.

### 22. Fuel Cut Valve

#### A: REMOVAL

##### WARNING:

- Place “NO FIRE” signs near the working area.
- Be careful not to spill fuel on the floor.
- During work procedures, if fuel tank is more than 3/4 full, be careful because fuel may spill.

1) Remove fuel tank. <Ref. to FU(SOHCw/oOBD)-48, REMOVAL, Fuel Tank.>

2) Move clip and disconnect evaporation hose from fuel cut valve.

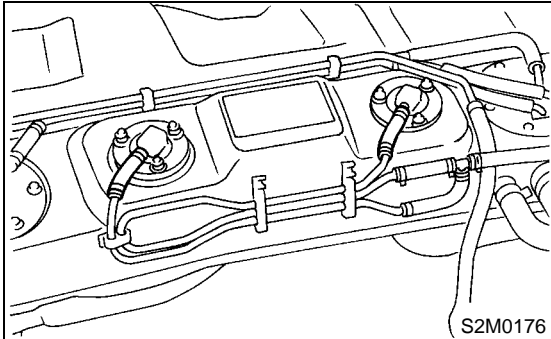

3) Remove bolts which install fuel cut valve.

#### B: INSTALLATION

Install in the reverse order of removal.

##### Tightening torque:

**4.4 N·m (0.45 kgf·m, 3.3 ft·lb)**

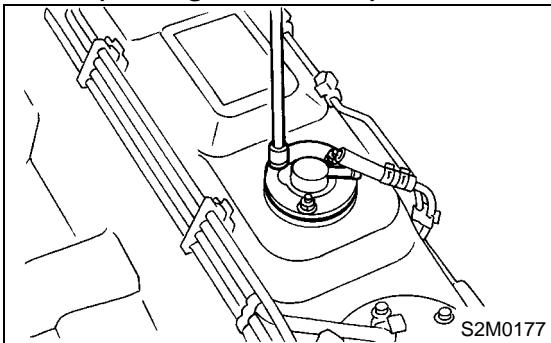

## 23. Fuel Damper Valve

### A: REMOVAL

- 1) Release fuel pressure. <Ref. to FU(DOHC TURBO)-49, RELEASING OF FUEL PRESSURE, OPERATION, Fuel.>
- 2) Remove fuel damper valve from fuel return line.

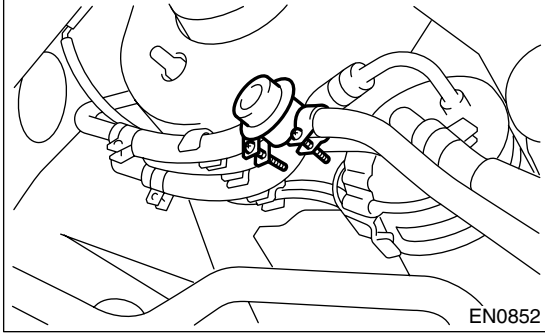

### B: INSTALLATION

Install in the reverse order of removal.

# FUEL DELIVERY, RETURN AND EVAPORATION LINES

## FUEL INJECTION (FUEL SYSTEMS)

### 24. Fuel Delivery, Return and Evaporation Lines

#### A: REMOVAL

- 1) Set vehicle on the lift.
- 2) Release fuel pressure. <Ref. to FU(SOHCw/oOBD)-47, RELEASING OF FUEL PRESSURE, OPERATION, Fuel.>

- 3) Open fuel filler flap lid and remove fuel filler cap.
- 4) Remove floor mat. <Ref. to EI-37, REMOVAL, Floor Mat.>
- 5) Remove fuel delivery pipes and hoses, fuel return pipes and hoses, evaporation pipes and hoses.

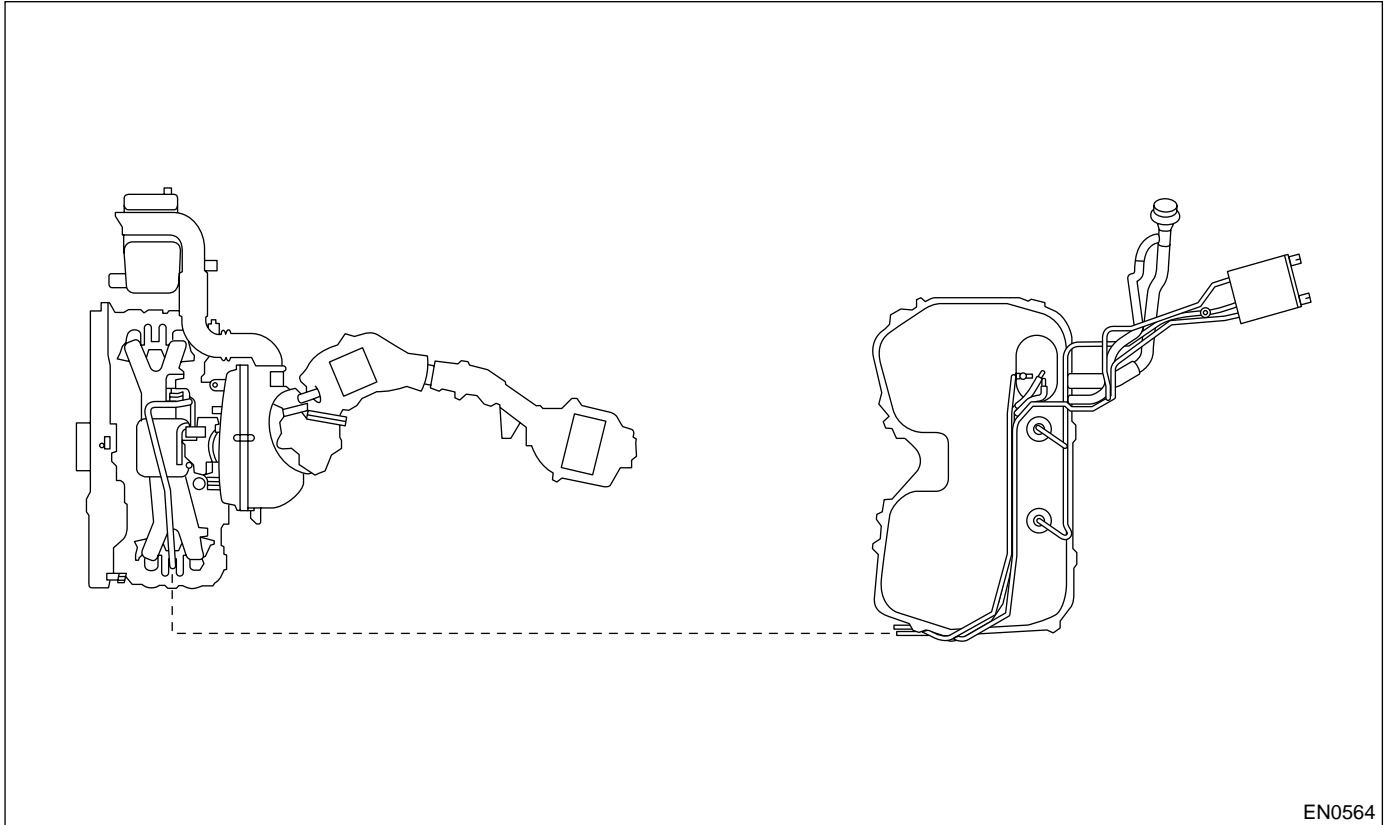

EN0564

- 6) In engine compartment, detach fuel delivery hoses, return hoses and evaporation hose.

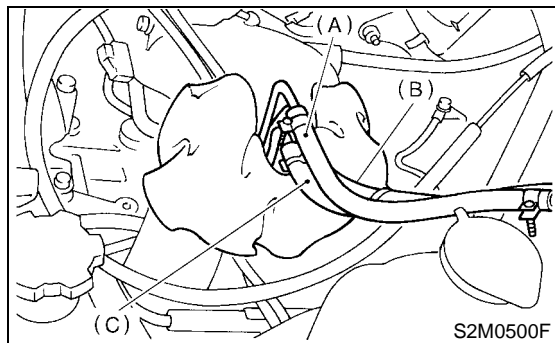

- (1) Fuel delivery hose
- (2) Return hose
- (3) Evaporation hose

- 7) Lift-up the vehicle.

- 8) Disconnect two-way valve hose (A) from two-way valve and disconnect canister hose (B) from canister.

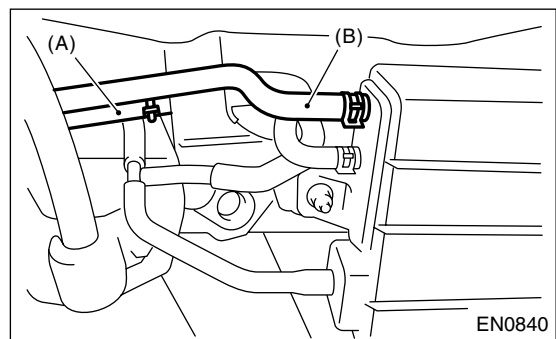

- 9) Separate quick connector on fuel delivery and return line.
  - (1) Clean pipe and connector, if they are covered with dust.
  - (2) Hold connector (A) and push retainer (B) down.
  - (3) Pull out connector (A) from retainer (B).

# FUEL DELIVERY, RETURN AND EVAPORATION LINES

FUEL INJECTION (FUEL SYSTEMS)

## CAUTION:

Replace retainer with new ones.

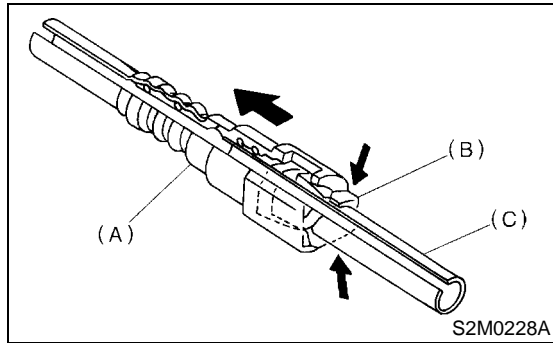

- (A) Connector
- (B) Retainer
- (C) Pipe

## B: INSTALLATION

1) Connect quick connector on fuel delivery line.

### CAUTION:

- Always use a new retainer.
- Make sure that the connected portion is not damaged or has dust. If necessary, clean seal surface of pipe.

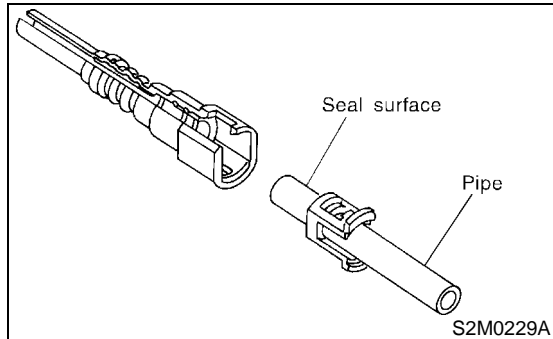

- (1) Set new retainer (B) to connector (A).
- (2) Push pipe into connector completely.

### NOTE:

At this time, two clicking sounds are heard.

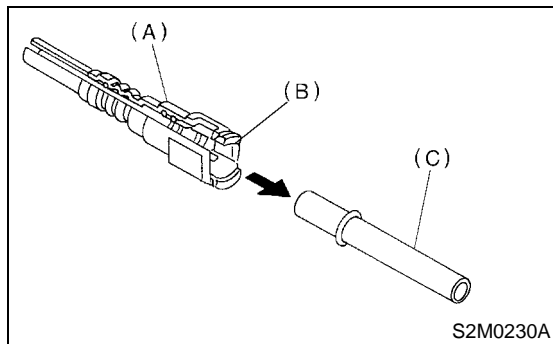

- (A) Connector
- (B) Retainer
- (C) Pipe

## CAUTION:

- Pull the connector to ensure it is connected securely.
- Ensure the two retainer pawls are engaged in their mating positions in the connector.
- Be sure to inspect hoses and their connections for any leakage of fuel.

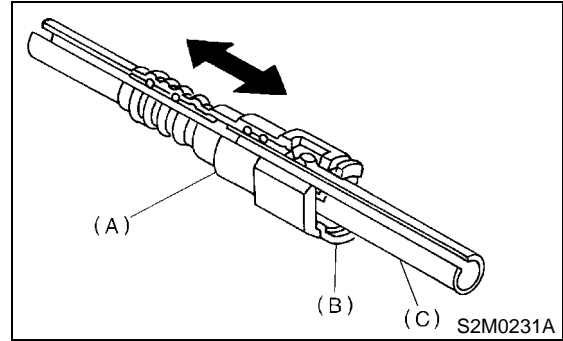

- (A) Connector
- (B) Retainer
- (C) Pipe

2) Connect fuel delivery hose to pipe with an overlap of 20 to 25 mm (0.79 to 0.98 in).

Type A: When fitting length is specified.

Type B: When fitting length is not specified.

$$\varnothing : 2.5 \pm 1.5 \text{ mm } (0.098 \pm 0.059 \text{ in})$$

$$L : 22.5 \pm 2.5 \text{ mm } (0.886 \pm 0.098 \text{ in})$$

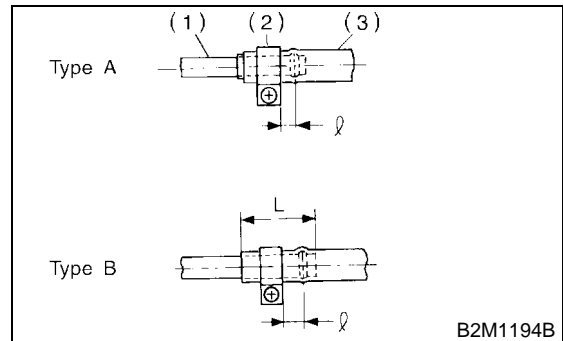

- (1) Fitting
- (2) Clamp
- (3) Hose

# FUEL DELIVERY, RETURN AND EVAPORATION LINES

## FUEL INJECTION (FUEL SYSTEMS)

---

3) Connect evaporation hose to pipe by approx. 15 mm (0.59 in) from hose end.

$L = 17.5 \pm 2.5 \text{ mm } (0.689 \pm 0.098 \text{ in})$

### CAUTION:

Be sure to inspect hoses and their connections for any leakage of fuel.

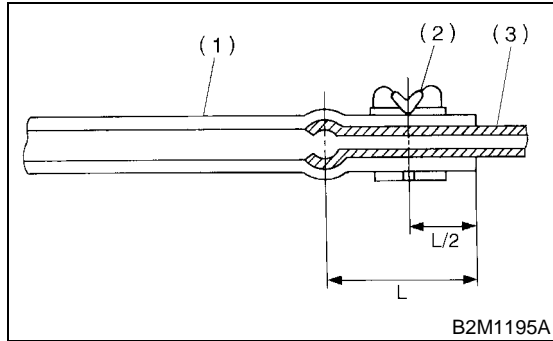

- (1) Hose
- (2) Clip
- (3) Pipe

## C: INSPECTION

- 1) Make sure that there are no cracks on the fuel pipes and fuel hoses.
- 2) Make sure that the fuel pipe and fuel hose connections are tight.

# FUEL SYSTEM TROUBLE IN GENERAL

FUEL INJECTION (FUEL SYSTEMS)

## 25. Fuel System Trouble in General

### A: INSPECTION

| Trouble and possible cause                         |  | Corrective action   |
|--|--|---|
| <b>1. Insufficient fuel supply to the injector</b> |  |   |
| 1)   | Fuel pump will not operate.  |   |
|  | ○ Defective terminal contact.  | Inspect connections, especially ground, and tighten securely. |
|  | ○ Trouble in electromagnetic or electronic circuit parts.              | Replace fuel pump.  |
| 2)   | Lowering of fuel pump function.  | Replace fuel pump.  |
| 3)   | Clogged dust or water in the fuel filter.                              | Replace fuel filter, clean or replace fuel tank.              |
| 4)   | Clogged or bent fuel pipe or hose.                                     | Clean, correct or replace fuel pipe or hose.                  |
| 5)   | Air is mixed in the fuel system.                                       | Inspect or retighten each connection part.                    |
| 6)   | Clogged or bent breather tube or pipe.                                 | Clean, correct or replace air breather tube or pipe.          |
| 7)   | Damaged diaphragm of pressure regulator.                               | Replace.  |
| <b>2. Leakage or blow out fuel</b>                 |  |   |
| 1)   | Loosened joints of the fuel pipe.                                      | Retightening.   |
| 2)   | Cracked fuel pipe, hose and fuel tank.                                 | Replace.  |
| 3)   | Defective welding part on the fuel tank.                               | Replace.  |
| 4)   | Defective drain packing of the fuel tank.                              | Replace.  |
| 5)   | Clogged or bent air breather tube or air vent tube.                    | Clean, correct or replace air breather tube or air vent tube. |
| <b>3. Gasoline smell inside of compartment</b>     |  |   |
| 1)   | Loose joints at air breather tube, air vent tube and fuel filler pipe. | Retightening.   |
| 2)   | Defective packing air tightness on the fuel saucer.                    | Correct or replace packing.                                   |
| 3)   | Cracked fuel separator.  | Replace separator.  |
| 4)   | Inoperative fuel pump modulator or circuit.                            | Replace.  |
| <b>4. Defective fuel meter indicator</b>           |  |   |
| 1)   | Defective operation of fuel meter unit.                                | Replace.  |
| 2)   | Defective operation of fuel meter.                                     | Replace.  |
| <b>5. Noise</b>                                    |  |   |
| 1)   | Large operation noise or vibration of fuel pump.                       | Replace.  |

#### NOTE:

- When the vehicle is left unattended for an extended period of time, water may accumulate in the fuel tank.

To prevent water condensation.

(1) Top off the fuel tank or drain the fuel completely.

(2) Drain water condensation from the fuel filter.

- Refilling the fuel tank.

Refill the fuel tank while there is still some fuel left in the tank.

- Protecting the fuel system against freezing and water condensation.

(3) Cold areas

In snow-covered areas, mountainous areas, skiing areas, etc. where ambient temperatures drop below 0°C (32°F) throughout the winter season, use an anti-freeze solution in the cooling system. Refueling will also complement the

effect of anti-freeze solution each time the fuel level drops to about one-half. After the winter season, drain water which may have accumulated in the fuel filter and fuel tank in the manner same as that described under Affected areas below.

(4) Affected areas

When water condensation is notched in the fuel filter, drain water from both the fuel filter and fuel tank or use a water removing agent (or anti-freeze solution) in the fuel tank.

- Observe the instructions, notes, etc., indicated on the label affixed to the anti-freeze solution (water removing agent) container before use.



# **FUEL SYSTEM TROUBLE IN GENERAL**

FUEL INJECTION (FUEL SYSTEMS)

---