

**ENGINE 2 SECTION**

This service manual has been prepared to provide SUBARU service personnel with the necessary information and data for the correct maintenance and repair of SUBARU vehicles.

This manual includes the procedures for maintenance, disassembling, reassembling, inspection and adjustment of components and diagnostics for guidance of experienced mechanics.

Please peruse and utilize this manual fully to ensure complete repair work for satisfying our customers by keeping their vehicle in optimum condition. When replacement of parts during repair work is needed, be sure to use SUBARU genuine parts.

All information, illustration and specifications contained in this manual are based on the latest product information available at the time of publication approval.

**FUEL INJECTION (FUEL SYSTEMS) FU(SOHCw/oOBD)**

**EMISSION CONTROL (AUX. EMISSION CONTROL DEVICES) EC(SOHCw/oOBD)**

**EXHAUST EX(SOHCw/oOBD)**

**IGNITION IG(SOHCw/oOBD)**

**ENGINE(DIAGNOSTICS) EN(SOHCw/oOBD)**

**FUEL INJECTION (FUEL SYSTEMS) FU(DOHC TURBO)**

**EMISSION CONTROL (AUX. EMISSION CONTROL DEVICES) EC(DOHC TURBO)**

**INTAKE (INDUCTION) IN(DOHC TURBO)**

**MECHANICAL ME(DOHC TURBO)**

**EXHAUST EX(DOHC TURBO)**

**IGNITION IG(DOHC TURBO)**

**ENGINE (DIAGNOSTICS) EN(DOHC TURBO)**

# EXHAUST

# *EX(DOHC TURBO)*

---

	<b>Page</b>
1. General Description .....	2
2. Front Exhaust Pipe.....	6
3. Center Exhaust Pipe .....	8
4. Joint Pipe .....	12
5. Rear Exhaust Pipe .....	13
6. Muffler .....	14

# GENERAL DESCRIPTION

EXHAUST

## 1. General Description

### A: COMPONENT

#### 1. FRONT EXHAUST PIPE

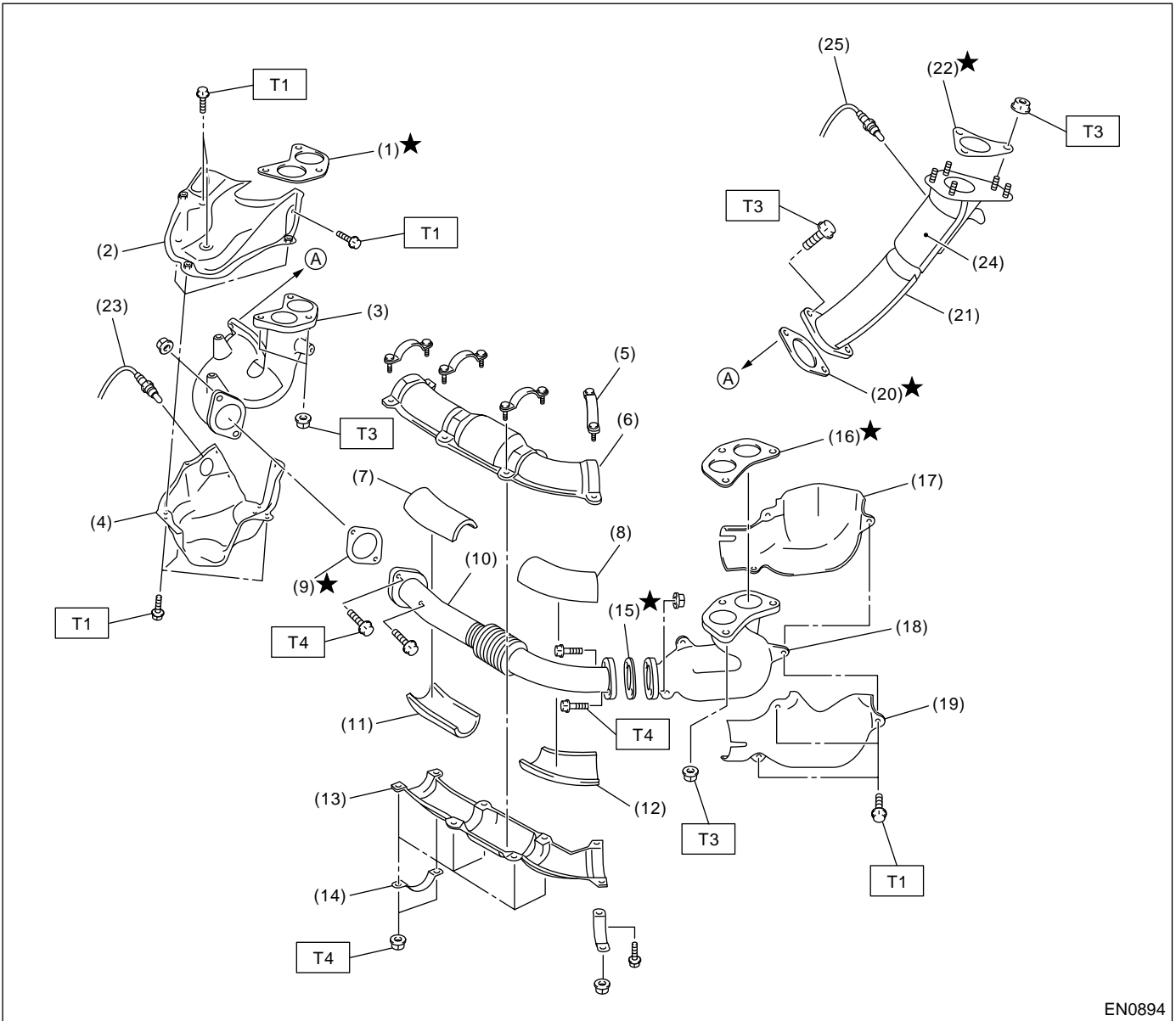

EN0894

EX(DOHC TURBO)-2

# GENERAL DESCRIPTION

EXHAUST

---

(1) Gasket	(11) Front exhaust pipe lower insulator (RH)	(21) Turbocharger joint pipe
(2) Upper exhaust manifold cover (RH)	(12) Front exhaust pipe lower insulator (LH)	(22) Gasket
(3) Exhaust manifold (RH)	(13) Front exhaust pipe lower cover	(23) Front oxygen (A/F) sensor
(4) Lower exhaust manifold cover (RH)	(14) Front exhaust pipe lower clamp	(24) Precatalytic converter
(5) Front exhaust pipe upper clamp	(15) Gasket	(25) Exhaust temperature sensor
(6) Front exhaust pipe upper cover	(16) Gasket	
(7) Front exhaust pipe upper insulator (RH)	(17) Upper exhaust manifold cover (LH)	
(8) Front exhaust pipe upper insulator (LH)	(18) Exhaust manifold (LH)	
(9) Gasket	(19) Lower exhaust manifold cover (LH)	
(10) Front exhaust pipe	(20) Gasket	

---

**Tightening torque: N·m (kgf·m, ft·lb)**

**T1: 18.6 (1.9, 13.7)**

**T2: 25 (2.5, 18.1)**

**T3: 35 (3.6, 26.0)**

**T4: 39 (4, 28.9)**

---

# GENERAL DESCRIPTION

## EXHAUST

### 2. CENTER AND REAR EXHAUST PIPE, AND MUFFLER

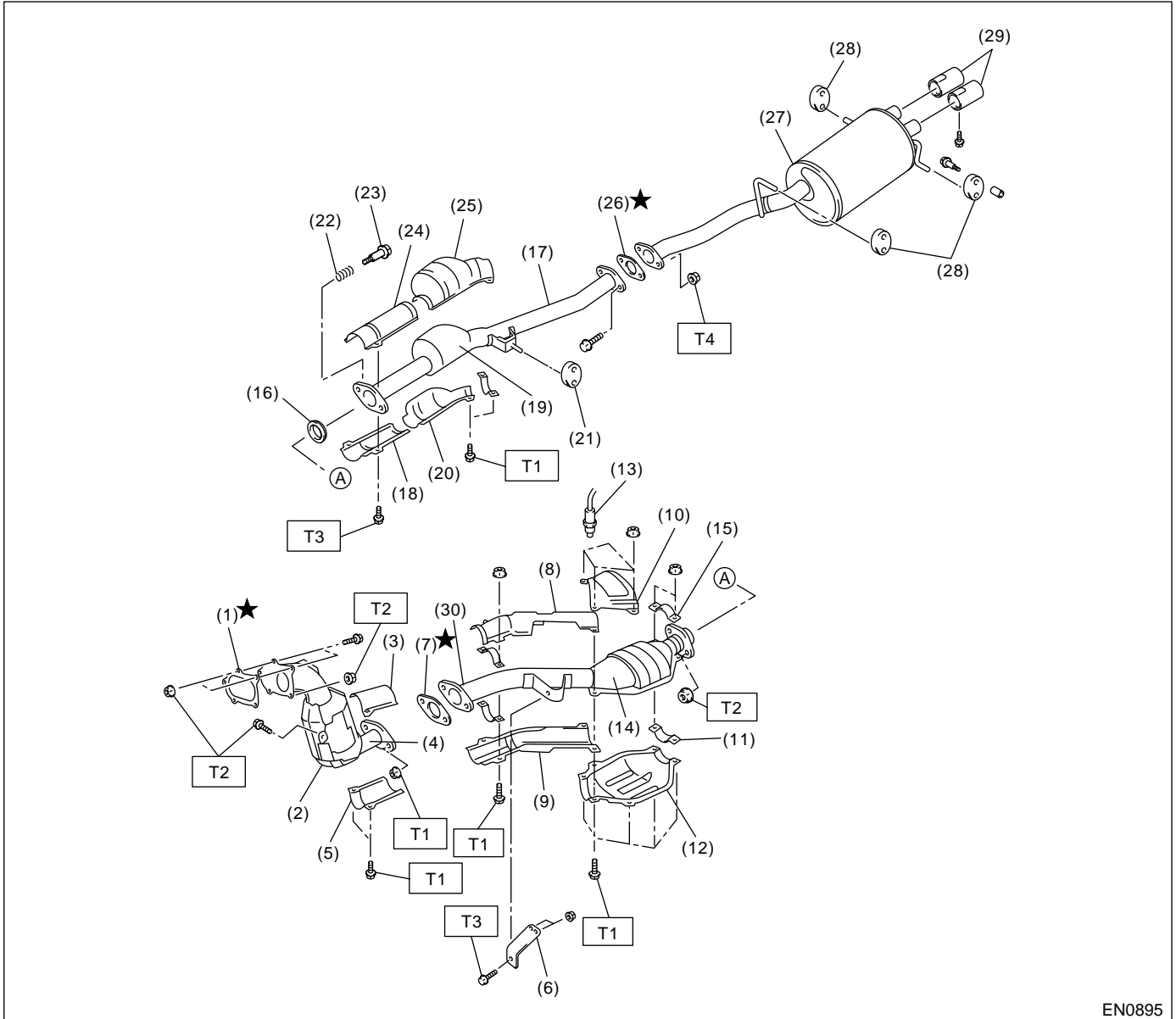

EN0895

- |   |  |   |
|---|--|---|
| (1) Gasket                                | (14) Rear catalytic converter              | (25) Upper rear exhaust pipe cover (Rear) |
| (2) Front catalytic converter             | (15) Upper clamp                           | (26) Gasket                               |
| (3) Upper center pipe cover (Front)       | (16) Gasket                                | (27) Muffler                              |
| (4) Center exhaust pipe (Front)           | (17) Rear exhaust pipe                     | (28) Cushion                              |
| (5) Lower center pipe cover (Front)       | (18) Lower rear exhaust pipe cover (Front) | (29) Muffler cutter                       |
| (6) Bracket                               | (19) Chamber                               | (30) Center exhaust pipe (Rear)           |
| (7) Gasket                                | (20) Lower rear exhaust pipe cover (Rear)  |   |
| (8) Upper center pipe cover (Rear)        | (21) Cushion                               |   |
| (9) Lower center pipe cover (Rear)        | (22) Spring                                |   |
| (10) Upper rear catalytic converter cover | (23) Bolt                                  |   |
| (11) Lower clamp                          | (24) Upper rear exhaust pipe cover (Front) |   |
| (12) Lower rear catalytic converter cover |  |   |
| (13) Rear oxygen sensor                   |  |   |

**Tightening torque: N·m (kgf·m, ft·lb)**

**T1: 18 (1.8, 13.0)**

**T2: 30 (3.1, 22.4)**

**T3: 35 (3.6, 26.0)**

**T4: 48 (4.9, 35.4)**

### **B: CAUTION**

- Wear working clothing, including a cap, protective goggles, and protective shoes during operation.
- Remove contamination including dirt and corrosion before removal, installation or disassembly.
- Keep the disassembled parts in order and protect them from dust or dirt.
- Before removal, installation or disassembly, be sure to clarify the failure. Avoid unnecessary removal, installation, disassembly, and replacement.
- Be careful not to burn your hands, because each part on the vehicle is hot after running.
- Be sure to tighten fasteners including bolts and nuts to the specified torque.
- Place shop jacks or safety stands at the specified points.
- Before disconnecting electrical connectors of sensors or units, be sure to disconnect negative terminal from battery.

# FRONT EXHAUST PIPE

EXHAUST

## 2. Front Exhaust Pipe

### A: REMOVAL

1) Disconnect battery ground cable.

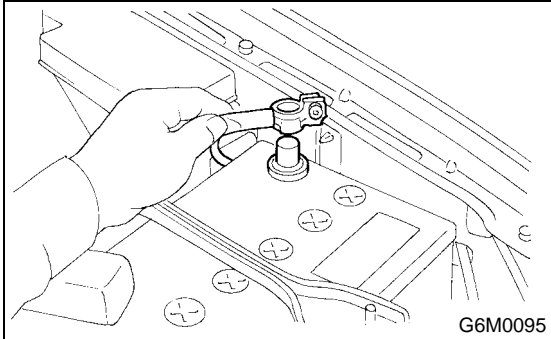

2) Remove front oxygen (A/F) sensor. <Ref. to FU(DOHC TURBO)-41, REMOVAL, Front Oxygen (A/F) Sensor.>

3) Remove under cover.

4) Remove lower exhaust manifold cover (RH).

5) Remove lower and upper exhaust manifold covers (LH).

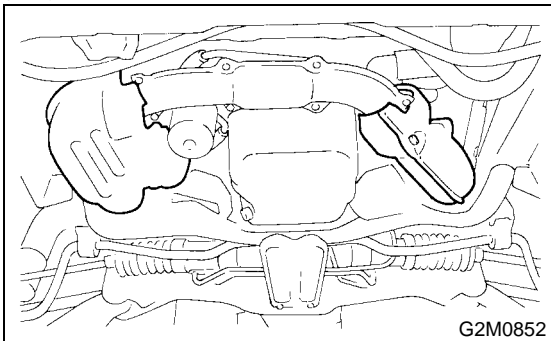

6) Remove bolts and nuts which hold front exhaust pipe assembly to turbocharger joint pipe.

7) While holding front exhaust pipe assembly with one hand, remove nuts which hold front exhaust pipe assembly to cylinder head exhaust port.

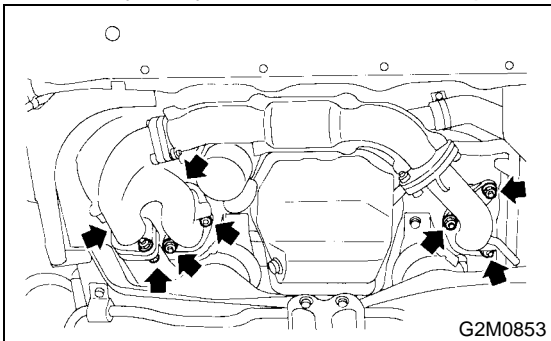

8) Remove front exhaust pipe assembly.

9) Remove covers from exhaust manifold and front exhaust pipe.

10) Separate front exhaust pipe from exhaust manifolds.

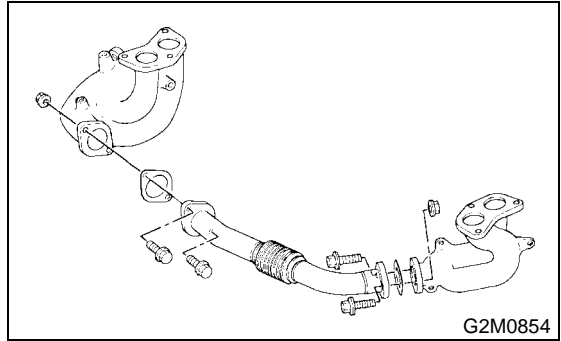

### B: INSTALLATION

#### CAUTION:

Replace gaskets with new ones.

1) Assemble front exhaust pipe and exhaust manifolds.

**Tightening torque:**

**39 N·m (4 kgf-m, 28.9 ft-lb)**

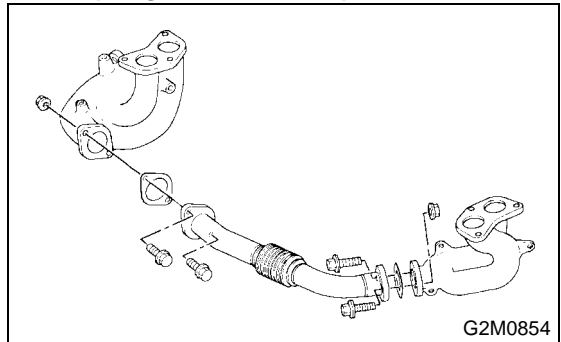

2) Install front exhaust pipe covers.

**Tightening torque:**

**25 N·m (2.5 kgf-m, 18.1 ft-lb)**

3) Install upper exhaust manifold cover (RH).

**Tightening torque:**

**18.6 N·m (1.9 kgf-m, 13.7 ft-lb)**

4) Install front exhaust pipe assembly.

**Tightening torque:**

**35 N·m (3.6 kgf-m, 26.0 ft-lb)**

5) Connect exhaust manifold (RH) to turbocharger joint pipe.

**Tightening torque:**

**35 N·m (3.6 kgf·m, 26.0 ft·lb)**

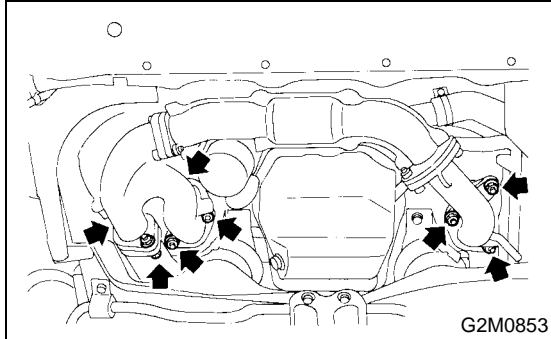

6) Install upper and lower exhaust manifold covers (LH).

**Tightening torque:**

**18.6 N·m (1.9 kgf·m, 13.7 ft·lb)**

7) Install lower exhaust manifold cover (RH).

**Tightening torque:**

**18.6 N·m (1.9 kgf·m, 13.7 ft·lb)**

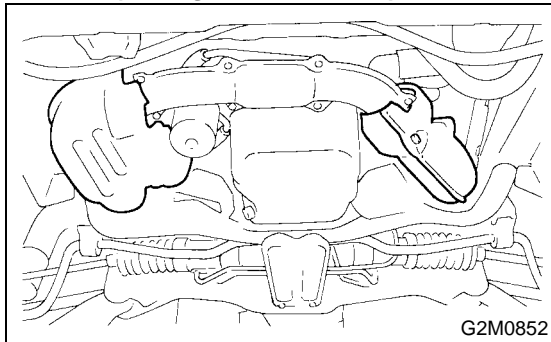

8) Install front oxygen (A/F) sensor. <Ref. to FU(DOHC TURBO)-42, INSTALLATION, Front Oxygen (A/F) Sensor.>

9) Install under cover.

10) Connect battery ground cable.

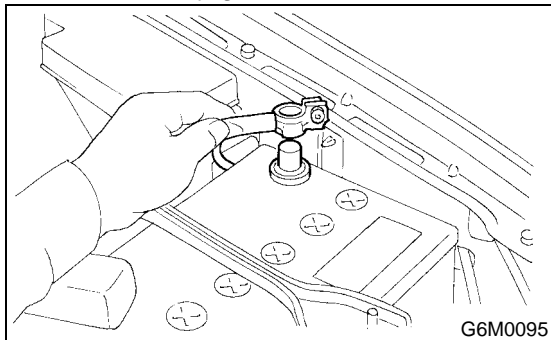



# CENTER EXHAUST PIPE

EXHAUST

## 3. Center Exhaust Pipe

### A: REMOVAL

- 1) Set the vehicle on the lift.
- 2) Disconnect battery ground cable.
- 3) Remove intercooler. <Ref. to IN(DOHC TURBO)-10, REMOVAL, Intercooler.>
- 4) Remove intercooler bracket.

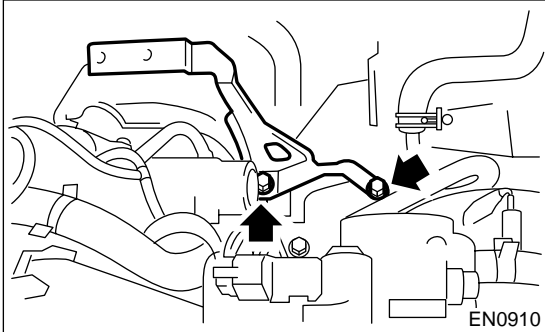

- 5) Lift-up the vehicle.
- 6) Remove under cover.
- 7) Remove universal joint bolts and then remove universal joint (RHD model only).

### CAUTION:

Scribe alignment marks on universal joint so that it can be reassembled at the original serration.

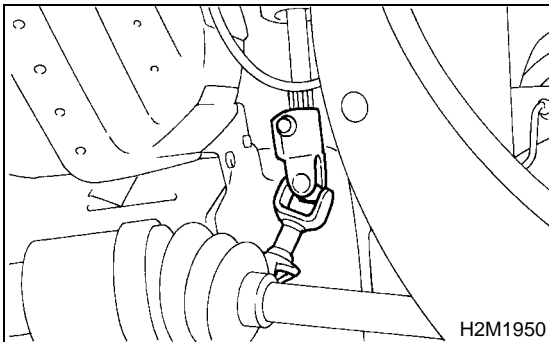

- 8) Remove bolts which install the lower side of turbocharger upper cover.

### CAUTION:

Be careful, turbocharger and exhaust pipe are hot.

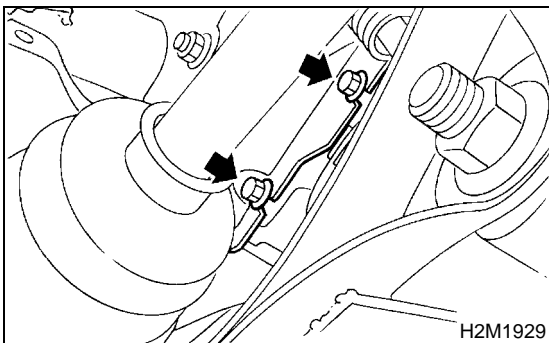

- 9) Lower the vehicle.

- 10) Remove turbocharger upper cover.

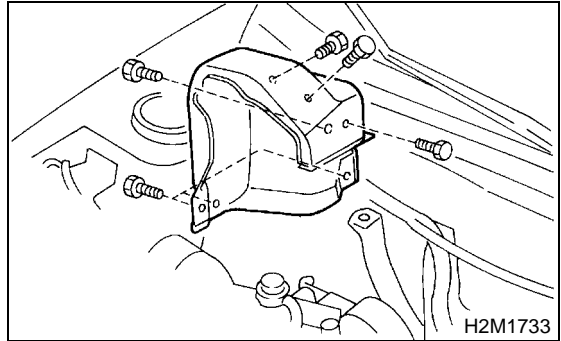

- 11) Remove bolts which install the lower upper side of turbocharger upper cover, and remove it.

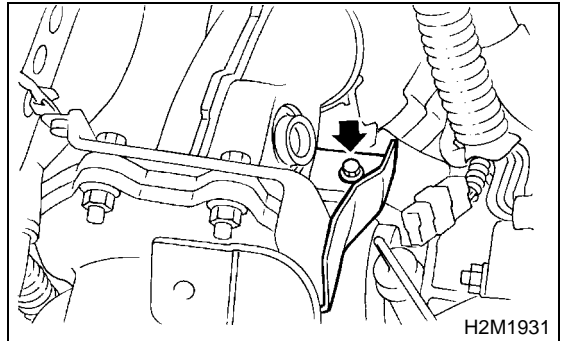

- 12) Separate center exhaust pipe from turbocharger.

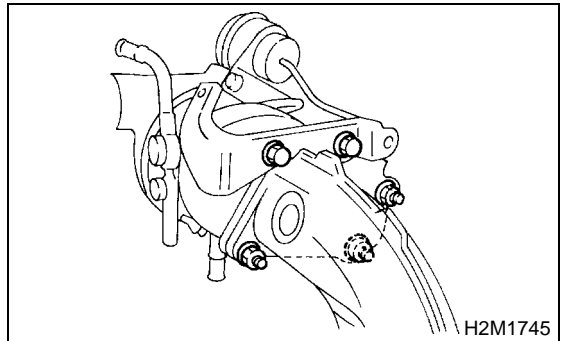

- 13) Lift-up the vehicle.
- 14) Disconnect connector from rear oxygen sensor.

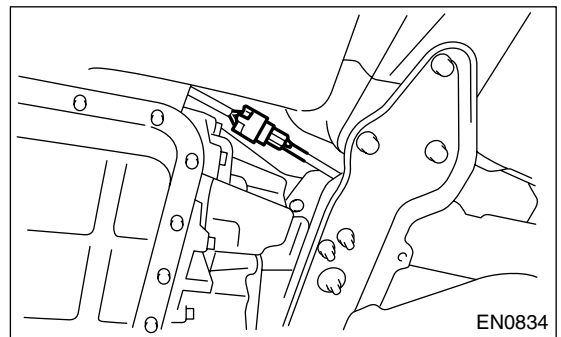

15) Separate center exhaust pipe from rear exhaust pipe.

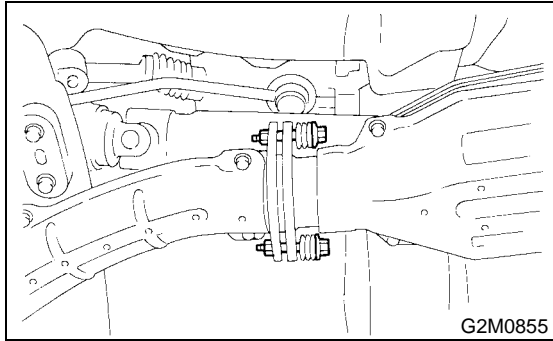

16) Remove bolt which holds center exhaust pipe bracket to transmission.

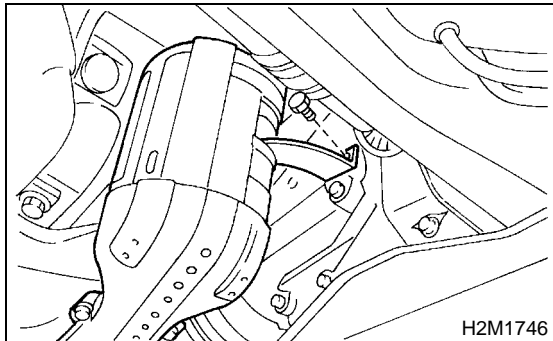

17) Remove intercooler bracket.

18) Remove bolt which holds center exhaust pipe to hanger bracket.

**CAUTION:**  
Be careful not to pull down center exhaust pipe.

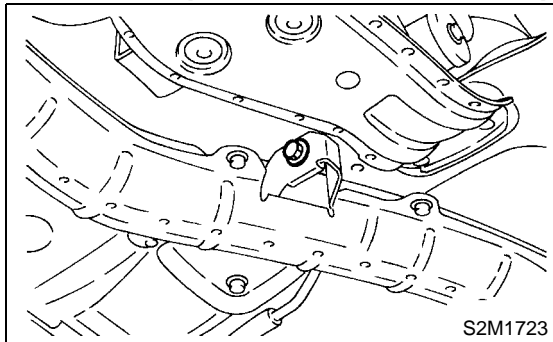

19) Remove center exhaust pipe.

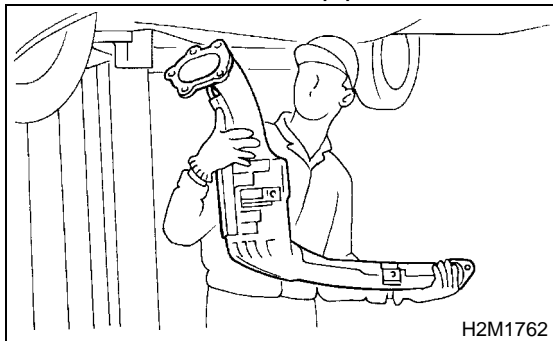

## B: INSTALLATION

### CAUTION:

Replace gaskets with new ones.

- 1) Install center exhaust pipe and temporarily tighten bolt which holds center exhaust pipe to hanger bracket.
- 2) Temporarily tighten bolt which holds center pipe to transmission.
- 3) Connect center exhaust pipe to turbocharger.

### Tightening torque:

**30 N·m (3.1 kgf·m, 22.4 ft·lb)**

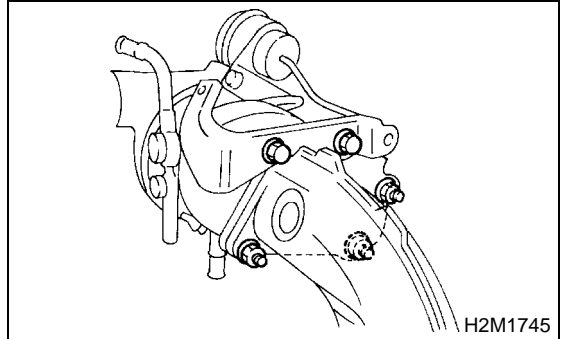

4) Install center exhaust pipe to rear exhaust pipe.

### Tightening torque:

**18 N·m (1.8 kgf·m, 13.0 ft·lb)**

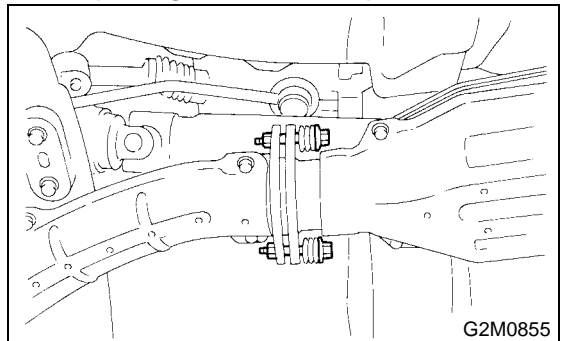

5) Connect connector to rear oxygen sensor.

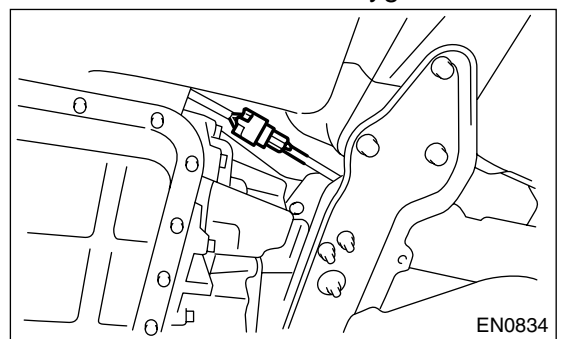

# CENTER EXHAUST PIPE

## EXHAUST

6) Tighten bolt which holds center exhaust pipe bracket to transmission.

**Tightening torque:**

**30 N·m (3.1 kgf-m, 22.4 ft-lb)**

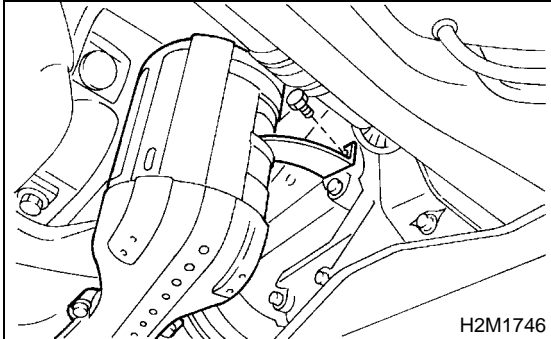

7) Tighten bolt which holds center exhaust pipe to hanger bracket.

**Tightening torque:**

**35 N·m (3.6 kgf-m, 26 ft-lb)**

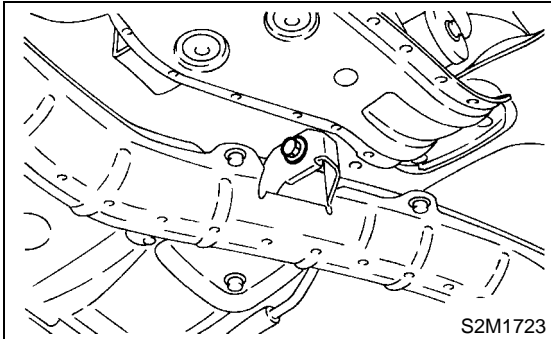

8) Tighten bolts which hold intercooler bracket.

**Tightening torque:**

**35 N·m (3.6 kgf-m, 26.0 ft-lb)**

9) Lower the vehicle.

10) Place turbocharger lower cover, and tighten bolts which install the upper side of lower cover.

**Tightening torque:**

**7.4 N·m (0.75 kgf-m, 5.4 ft-lb)**

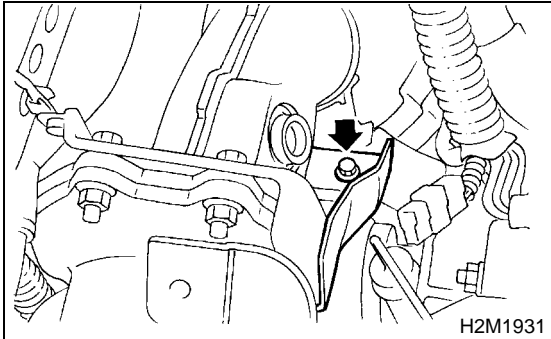

11) Place turbocharger upper cover, and tighten bolts which install the upper side of upper cover.

**Tightening torque:**

**7.4 N·m (0.75 kgf-m, 5.4 ft-lb)**

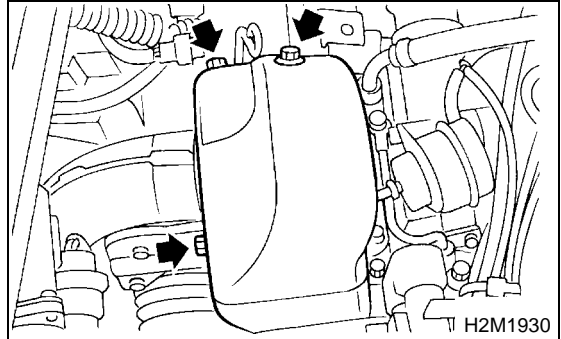

12) Lift-up the vehicle.

13) Tighten bolts which install the under side of turbocharger upper cover.

**Tightening torque:**

**7.4 N·m (0.75 kgf-m, 5.4 ft-lb)**

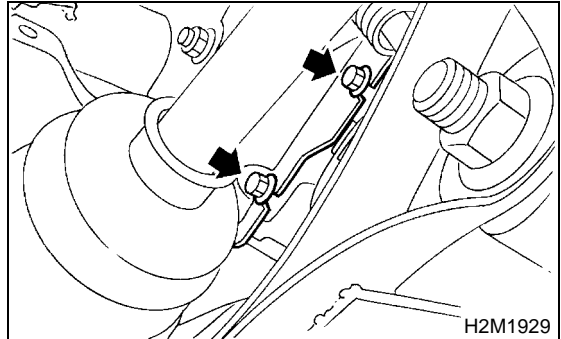

14) Install universal joint (RHD model only).

(1) Align bolt hole on the long yoke side of universal joint with the cutout at the serrated section of shaft end, and insert universal joint.

(2) Align bolt hole on the short yoke side of universal joint with the cutout at the serrated section of gearbox assembly. Lower universal joint completely.

(3) Temporarily tighten bolt on the short yoke side. Raise universal joint to make sure the bolt is properly passing through the cutout at the serrated section.

(4) Tighten bolt on the long yoke side, then that on the short yoke side.

**Tightening torque:**

**24 N·m (2.4 kgf-m, 17.4 ft-lb)**

**CAUTION:**

- Make sure that universal joint bolts are tightened through notches in shaft serration.

- Excessively large tightening torque of universal joint bolts may lead to heavy steering wheel operation.

**Standard clearance between gearbox to DOJ:**  
**Over 15 mm (0.59 in)**

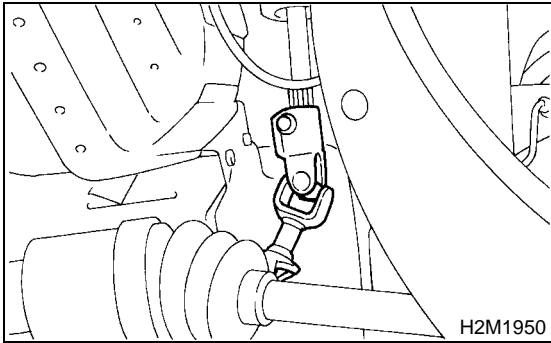

- 15) Install under cover.
- 16) Lower the vehicle.
- 17) Install intercooler bracket.

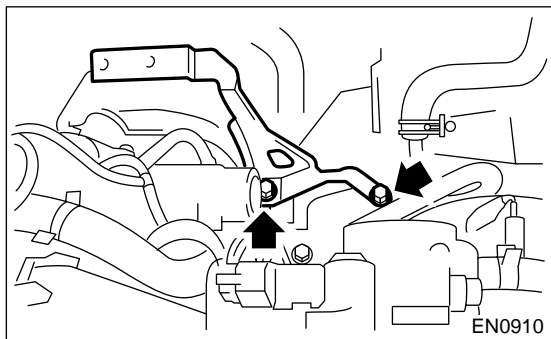

- 18) Install intercooler. <Ref. to IN(DOHC TURBO)-11, INSTALLATION, Intercooler.>
- 19) Align center of roll connector. (With airbag model) <Ref. to AB-11, ROLL CONNECTOR, INSPECTION, Inspection Locations After a Collision.>

# JOINT PIPE

## EXHAUST

### 4. Joint Pipe

#### A: REMOVAL

1) Disconnect battery ground cable.

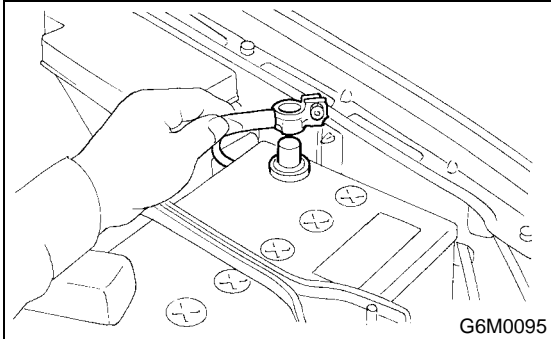

2) Remove solenoid valve cover.

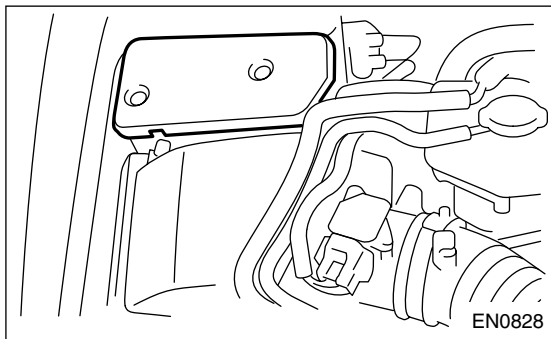

3) Disconnecter from exhaust temperature sensor connector.

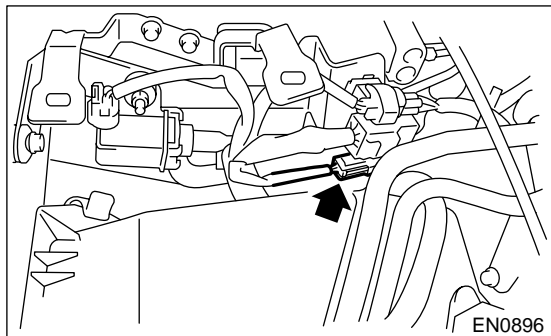

4) Remove front oxygen (A/F) sensor. <Ref. to FU(DOHC TURBO)-41, REMOVAL, Front Oxygen (A/F) Sensor.>

5) Remove under cover.

6) Remove lower exhaust manifold cover (RH).

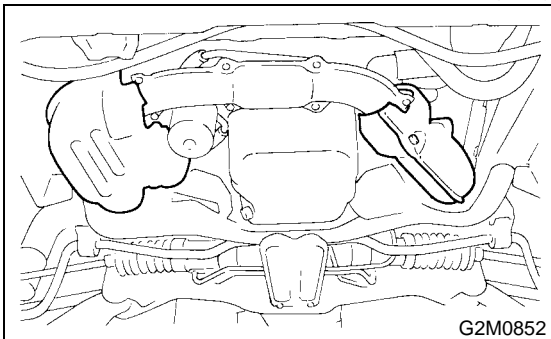

7) Remove nuts. Which hold front exhaust manifold to joint pipe.

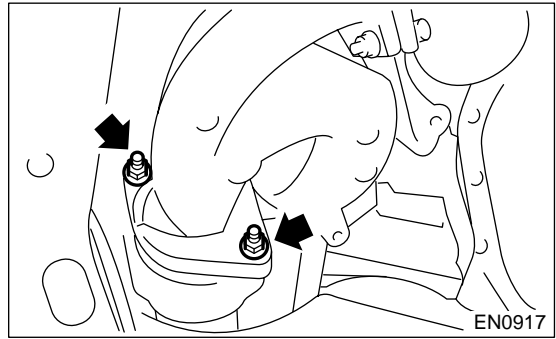

8) Remove center exhaust pipe. <Ref. to EX(DOHC TURBO)-8, REMOVAL, Center Exhaust Pipe.>

9) Remove turbocharger. <Ref. to IN(DOHC TURBO)-12, REMOVAL, Turbocharger.>

10) Take off joint pipe in the upward direction.

#### B: INSTALLATION

Install in the reverse order of removal.

**Tightening torque:**

**35 N·m (3.6 kgf·m, 26.0 ft·lb)**

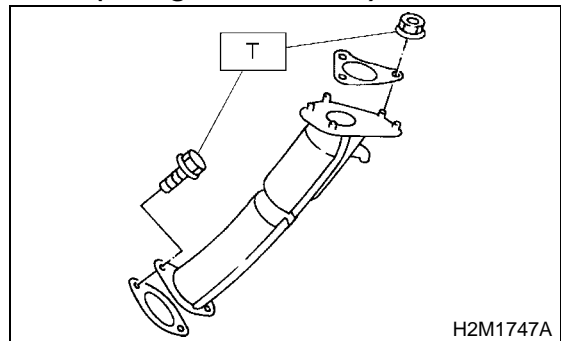

## 5. Rear Exhaust Pipe

### A: REMOVAL

- 1) Disconnect battery ground cable.

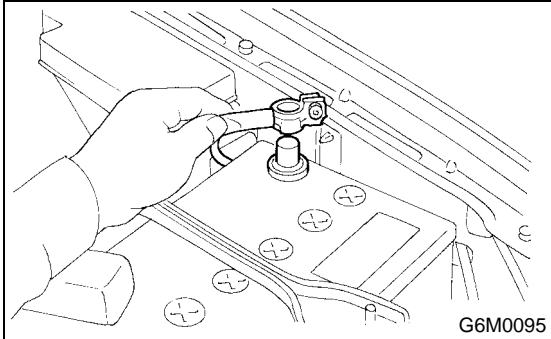

- 2) Lift up the vehicle.
- 3) Separate rear exhaust pipe from center exhaust pipe.

**CAUTION:**  
Be careful, exhaust pipe is hot.

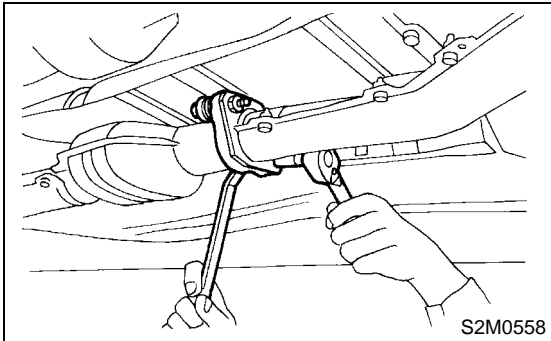

- 4) Separate rear exhaust pipe from muffler.

**CAUTION:**  
Be careful not to pull down rear exhaust pipe.

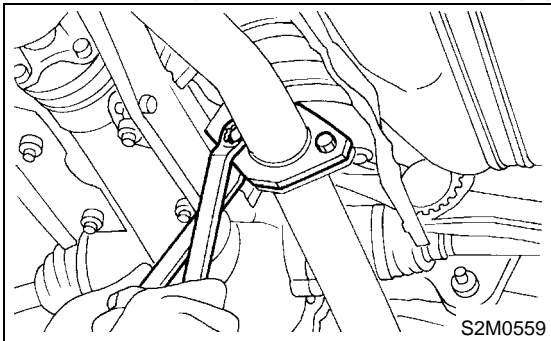

- 5) Remove rear exhaust pipe.

### B: INSTALLATION

**CAUTION:**

Replace gaskets with new ones.

- 1) Install rear exhaust pipe to muffler.

**Tightening torque:**

**48 N·m (4.9 kgf·m, 35.4 ft·lb)**

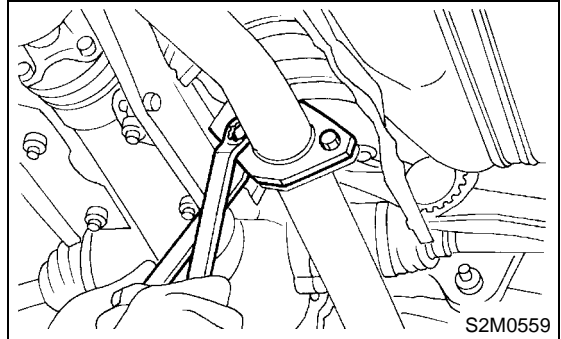

- 2) Install rear exhaust pipe to center exhaust pipe.

**Tightening torque:**

**18 N·m (1.8 kgf·m, 13.0 ft·lb)**

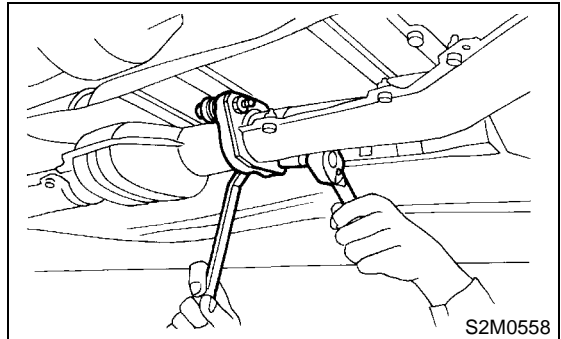

- 3) Lower the vehicle.
- 4) Connect battery ground cable.

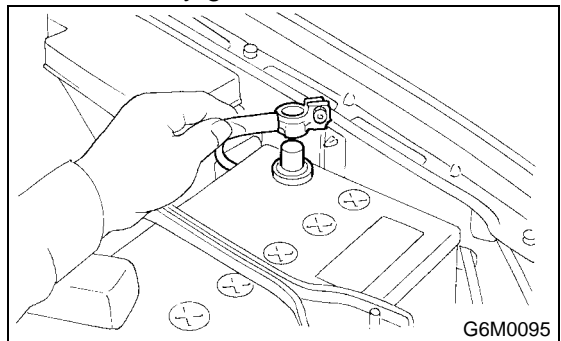

### C: INSPECTION

- 1) Make sure there are no exhaust leaks from connections and welds.
- 2) Make sure there are no holes or rusting.
- 3) Make sure the cushion rubber is not worn or cracked.

# MUFFLER

## EXHAUST

### 6. Muffler

#### A: REMOVAL

1) Separate muffler from rear exhaust pipe.

#### CAUTION:

Be careful, exhaust pipe is hot.

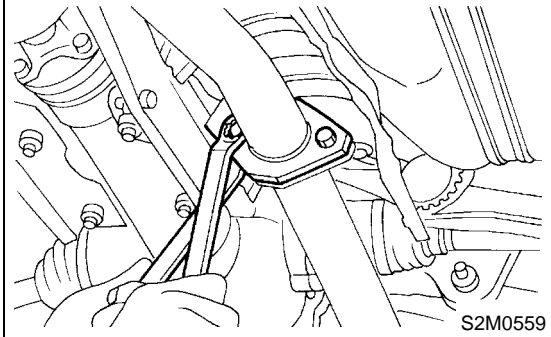

2) Remove rubber cushions, and detach muffler.

#### CAUTION:

Be careful not to drop the muffler during removal.

#### NOTE:

To facilitate removal, apply a coat of SUBARU CRC to mating area of rubber cushions in advance.

**SUBARU CRC (Part No. 004301003)**

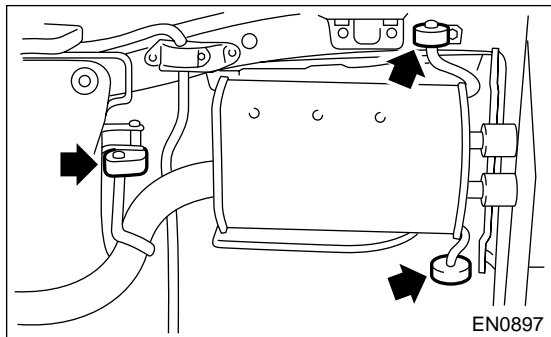

#### B: INSTALLATION

1) Install in the reverse order of removal.

#### CAUTION:

Replace gasket with a new one.

#### Tightening torque:

**48 N·m (4.9 kgf-m, 35.4 ft-lb)**

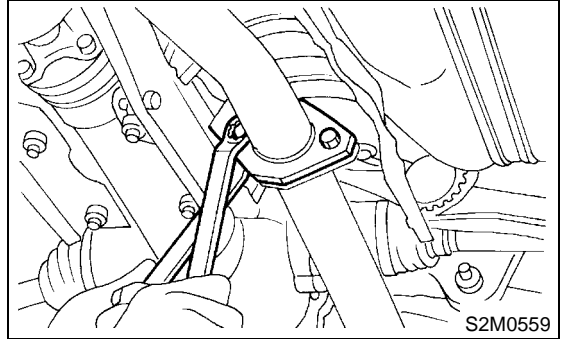

#### C: INSPECTION

- 1) Make sure there are no exhaust leaks from connections and welds.
- 2) Make sure there are no holes or rusting.
- 3) Make sure the cushion rubber is not worn or cracked.