

ENGINE 2 SECTION

This service manual has been prepared to provide SUBARU service personnel with the necessary information and data for the correct maintenance and repair of SUBARU vehicles.

This manual includes the procedures for maintenance, disassembling, reassembling, inspection and adjustment of components and diagnostics for guidance of experienced mechanics.

Please peruse and utilize this manual fully to ensure complete repair work for satisfying our customers by keeping their vehicle in optimum condition. When replacement of parts during repair work is needed, be sure to use SUBARU genuine parts.

All information, illustration and specifications contained in this manual are based on the latest product information available at the time of publication approval.

FUEL INJECTION (FUEL SYSTEMS) FU(SOHCw/oOBD)

EMISSION CONTROL (AUX. EMISSION CONTROL DEVICES) EC(SOHCw/oOBD)

EXHAUST EX(SOHCw/oOBD)

IGNITION IG(SOHCw/oOBD)

ENGINE(DIAGNOSTICS) EN(SOHCw/oOBD)

FUEL INJECTION (FUEL SYSTEMS) FU(DOHC TURBO)

EMISSION CONTROL (AUX. EMISSION CONTROL DEVICES) EC(DOHC TURBO)

INTAKE (INDUCTION) IN(DOHC TURBO)

MECHANICAL ME(DOHC TURBO)

EXHAUST EX(DOHC TURBO)

IGNITION IG(DOHC TURBO)

ENGINE (DIAGNOSTICS) EN(DOHC TURBO)

EMISSION CONTROL (AUX. EMISSION CONTROL DEVICES) *EC(SOHCw/oOBD)*

	Page
1. General Description	2
2. Front Catalytic Converter	3
3. Rear Catalytic Converter	6
4. Canister	7
5. Purge Control Solenoid Valve	8
6. Two-way Valve	9

GENERAL DESCRIPTION

EMISSION CONTROL (AUX. EMISSION CONTROL DEVICES)

1. General Description

A: CAUTION

- Wear working clothing, including a cap, protective goggles, and protective shoes during operation.
- Remove contamination including dirt and corrosion before removal, installation or disassembly.
- Keep the disassembled parts in order and protect them from dust or dirt.
- Before removal, installation or disassembly, be sure to clarify the failure. Avoid unnecessary removal, installation, disassembly, and replacement.
- Be careful not to burn your hands, because each part on the vehicle is hot after running.
- Be sure to tighten fasteners including bolts and nuts to the specified torque.
- Place shop jacks or safety stands at the specified points.
- Before disconnecting electrical connectors of sensors or units, be sure to disconnect negative terminal from battery.

FRONT CATALYTIC CONVERTER

EMISSION CONTROL (AUX. EMISSION CONTROL DEVICES)

2. Front Catalytic Converter

A: REMOVAL

- 1) Set the vehicle on the lift.
- 2) Disconnect battery ground cable.

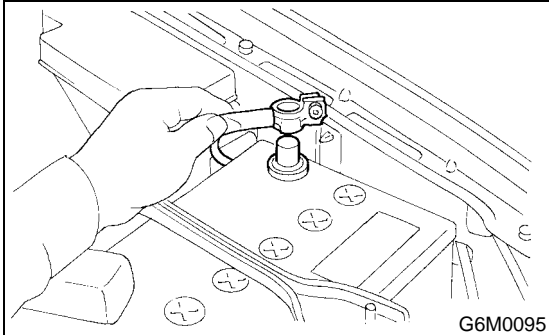

- 3) Disconnect front oxygen sensor connector.

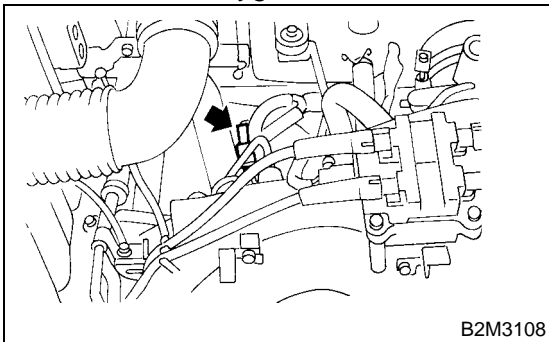

- 4) Lift-up the vehicle.
- 5) Remove under cover.
- 6) Separate center exhaust pipe from rear exhaust pipe.

CAUTION:

Be careful, exhaust pipe is hot.

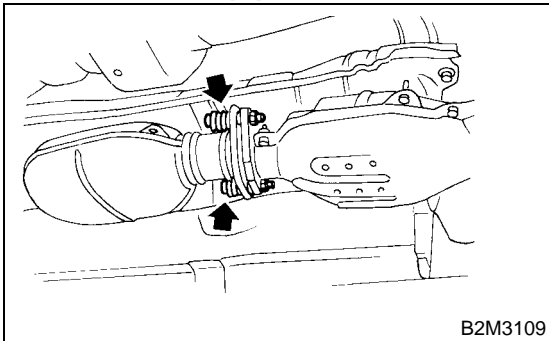

- 7) Remove bolts which hold front exhaust pipe onto cylinder heads.

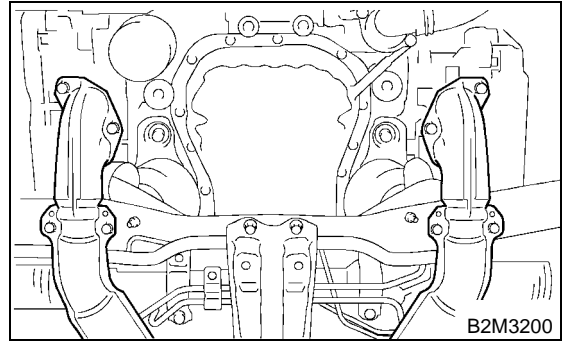

- 8) Remove front exhaust pipe and center exhaust pipe from hanger bracket.

CAUTION:

Be careful not to pull down front exhaust pipe and center exhaust pipe.

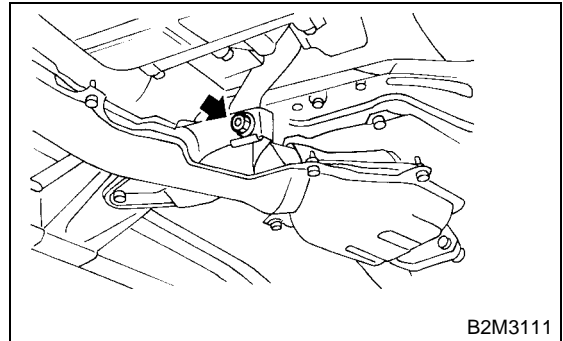

- 9) Separate front catalytic converter from front exhaust pipe.

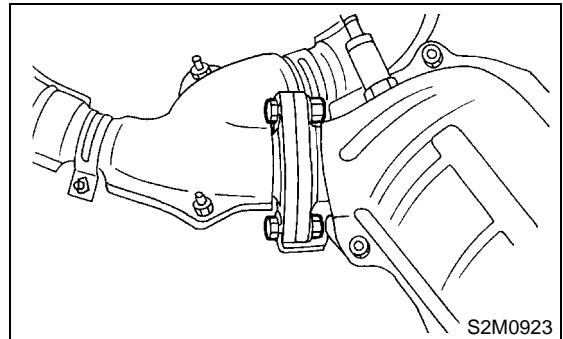

FRONT CATALYTIC CONVERTER

EMISSION CONTROL (AUX. EMISSION CONTROL DEVICES)

B: INSTALLATION

CAUTION:

Replace gaskets with new ones.

1) Install front catalytic converter to front exhaust pipe.

Tightening torque:

30 N-m (3.1 kgf-m, 22.4 ft-lb)

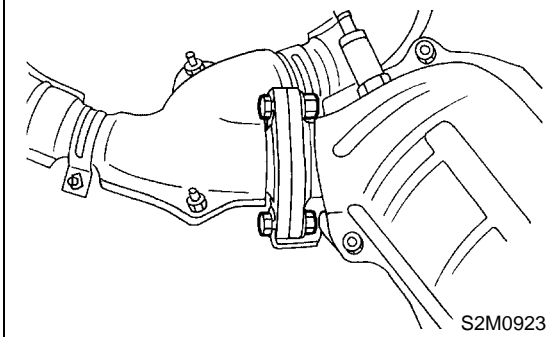

2) Install front exhaust pipe and center exhaust pipe. And temporarily tighten bolt which installs center exhaust pipe to hanger bracket.

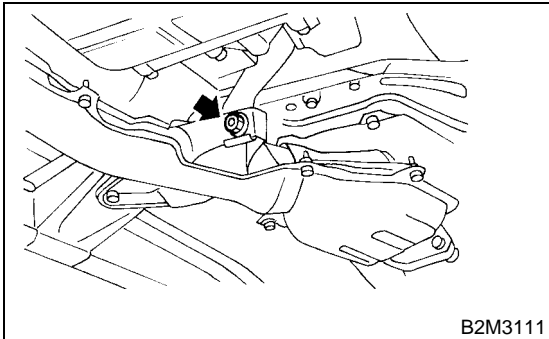

3) Tighten bolts which hold front exhaust pipe onto cylinder heads.

Tightening torque:

30 N-m (3.1 kgf-m, 22.4 ft-lb)

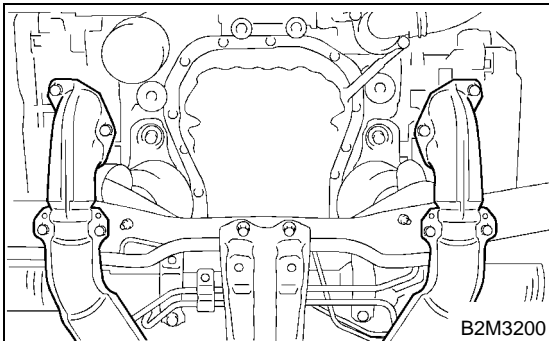

4) Install center exhaust pipe to rear exhaust pipe.

Tightening torque:

18 N-m (1.8 kgf-m, 13.0 ft-lb)

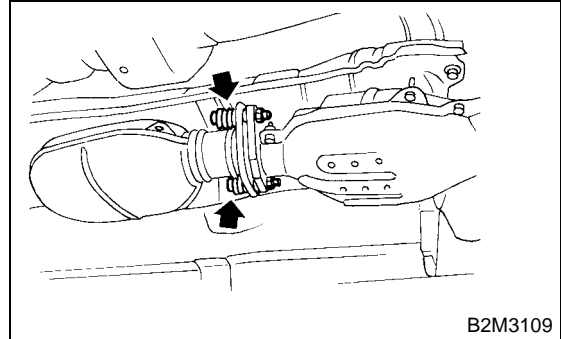

5) Tighten bolt which holds center exhaust pipe to hanger bracket.

Tightening torque:

35 N-m (3.6 kgf-m, 26.0 ft-lb)

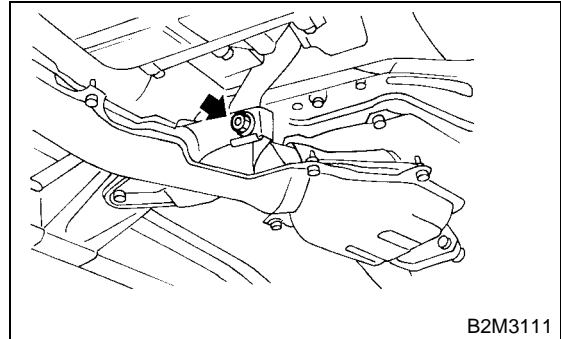

6) Install under cover.

7) Lower the vehicle.

8) Connect front oxygen sensor connector.

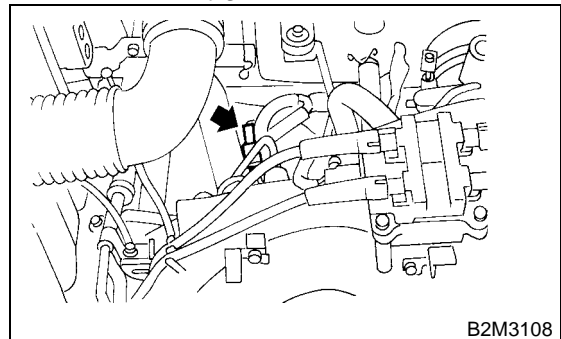

FRONT CATALYTIC CONVERTER

EMISSION CONTROL (AUX. EMISSION CONTROL DEVICES)

9) Connect battery ground cable.

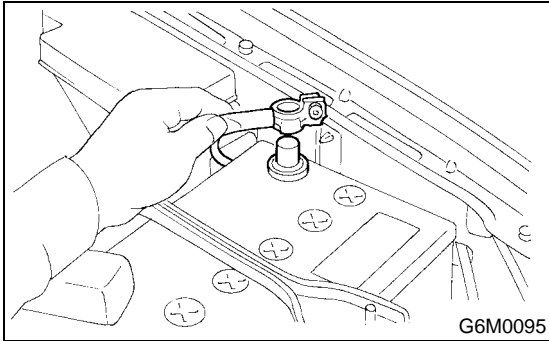

C: INSPECTION

- 1) Make sure there are no exhaust leaks from connections and welds.
- 2) Make sure there are no holes or rusting.

REAR CATALYTIC CONVERTER

EMISSION CONTROL (AUX. EMISSION CONTROL DEVICES)

3. Rear Catalytic Converter

A: REMOVAL

The front and rear catalytic converter and center exhaust pipe are integrated into one unit. Therefore, the removal and installation procedures are the same as the those for the front catalytic converter. <Ref. to EC(SOHCw/oOBD)-3, REMOVAL, Front Catalytic Converter.>

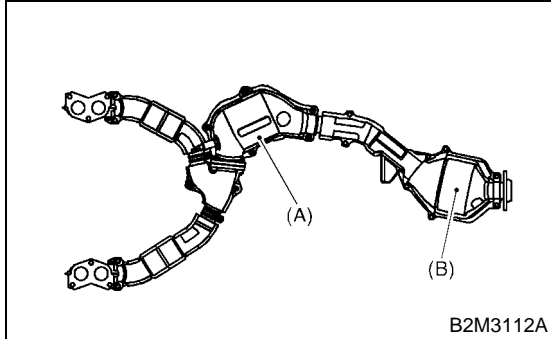

- (A) Front catalytic converter
- (B) Rear catalytic converter

B: INSTALLATION

The front and rear catalytic converter and center exhaust pipe are integrated into one unit. Therefore, the removal and installation procedures are the same as the ones described under front catalytic converter. <Ref. to EC(SOHCw/oOBD)-4, INSTALLATION, Front Catalytic Converter.>

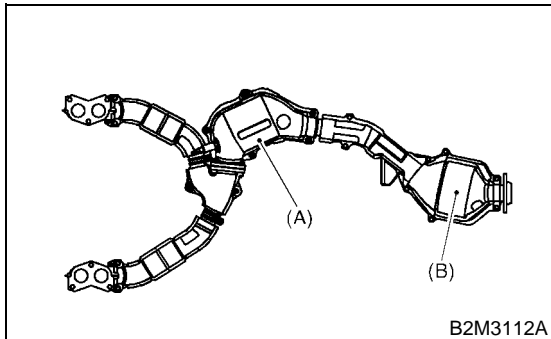

- (A) Front catalytic converter
- (B) Rear catalytic converter

C: INSPECTION

- 1) Make sure there are no exhaust leaks from connections and welds.
- 2) Make sure there are no holes or rusting.

CANISTER

EMISSION CONTROL (AUX. EMISSION CONTROL DEVICES)

4. Canister

A: REMOVAL

- 1) Lift-up the vehicle.
- 2) Loosen two clamps which hold two canister hoses, and disconnect evaporation three hoses from canister.

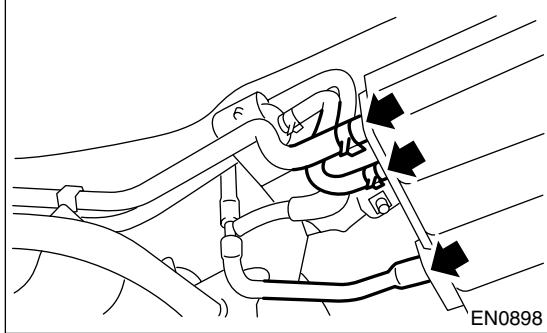

- 3) Remove canister from body.

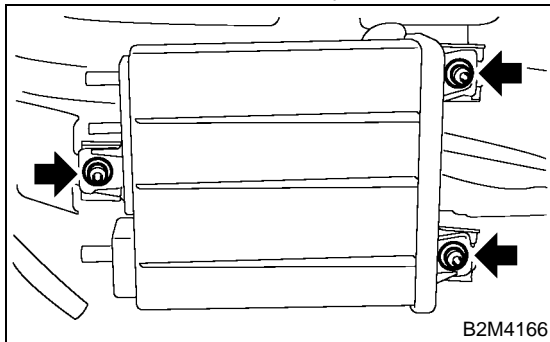

B: INSTALLATION

- 1) Install in the reverse order of removal.

Tightening torque:

23 N·m (2.3 kgf-m, 17 ft-lb)

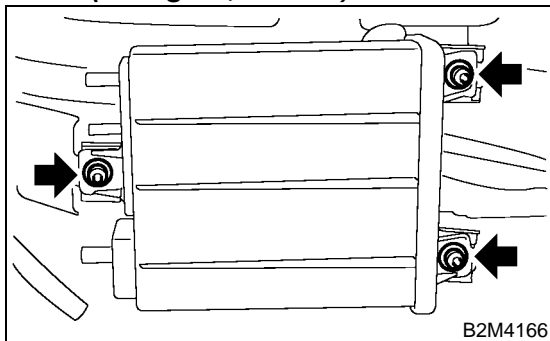

C: INSPECTION

Make sure the canister and canister hoses are not cracked or loose.

PURGE CONTROL SOLENOID VALVE

EMISSION CONTROL (AUX. EMISSION CONTROL DEVICES)

5. Purge Control Solenoid Valve

A: REMOVAL

1) Disconnect battery ground cable.

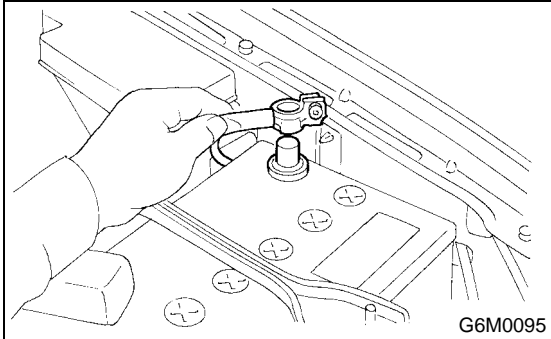

2) Remove bolt which installs purge control solenoid valve onto intake manifold.

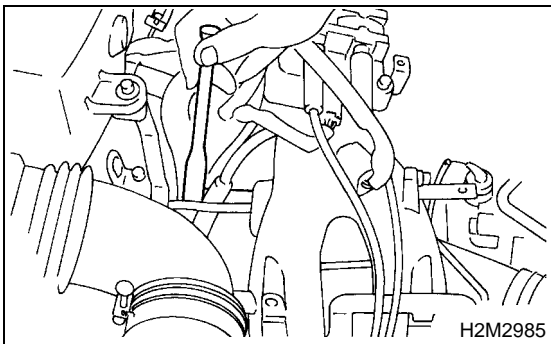

3) Take out purge control solenoid valve through the bottom of the intake manifold.

4) Disconnect connector and hoses from purge control solenoid valve.

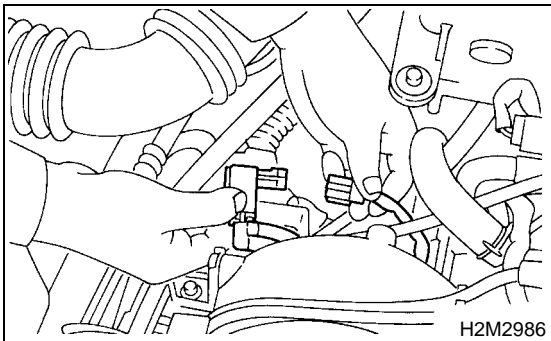

B: INSTALLATION

Install in the reverse order of removal.

Tightening torque:

16 N·m (1.6 kgf-m, 11.6 ft-lb)

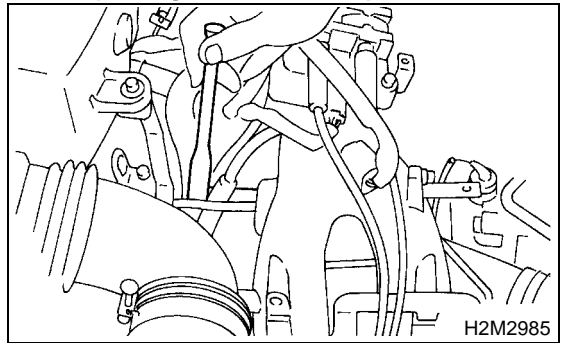

CAUTION:

Carefully connect the evaporation hoses.

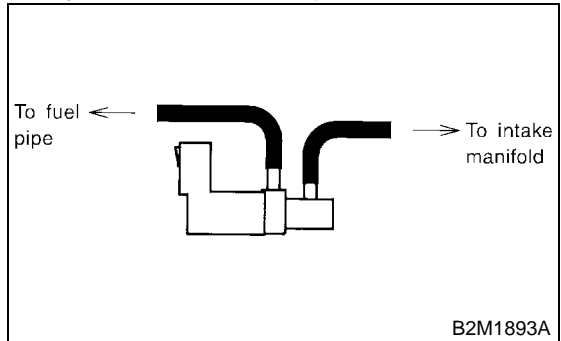

C: INSPECTION

Make sure hoses are not cracked or loose.

TWO-WAY VALVE

EMISSION CONTROL (AUX. EMISSION CONTROL DEVICES)

6. Two-way Valve

A: REMOVAL

- 1) Lift-up the vehicle.
- 2) Remove canister from body. <Ref. to EC(SOHCw/oOBD)-7, REMOVAL, Canister.>
- 3) Remove two-way valve with bracket as a single unit from body.

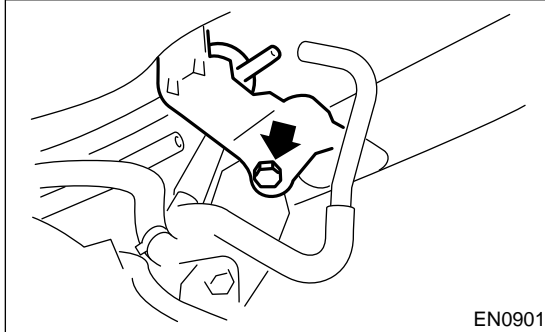

- 4) Remove two-way valve from bracket.

B: INSTALLTION

Install in the reverse order of removal.

C: INSPECTION

Make sure that hoses are not cracked or loose.

TWO-WAY VALVE

EMISSION CONTROL (AUX. EMISSION CONTROL DEVICES)
