

**ENGINE 2 SECTION**

This service manual has been prepared to provide SUBARU service personnel with the necessary information and data for the correct maintenance and repair of SUBARU vehicles.

This manual includes the procedures for maintenance, disassembling, reassembling, inspection and adjustment of components and diagnostics for guidance of experienced mechanics.

Please peruse and utilize this manual fully to ensure complete repair work for satisfying our customers by keeping their vehicle in optimum condition. When replacement of parts during repair work is needed, be sure to use SUBARU genuine parts.

All information, illustration and specifications contained in this manual are based on the latest product information available at the time of publication approval.

**FUEL INJECTION (FUEL SYSTEMS) FU(SOHCw/oOBD)**

**EMISSION CONTROL (AUX. EMISSION CONTROL DEVICES) EC(SOHCw/oOBD)**

**EXHAUST EX(SOHCw/oOBD)**

**IGNITION IG(SOHCw/oOBD)**

**ENGINE(DIAGNOSTICS) EN(SOHCw/oOBD)**

**FUEL INJECTION (FUEL SYSTEMS) FU(DOHC TURBO)**

**EMISSION CONTROL (AUX. EMISSION CONTROL DEVICES) EC(DOHC TURBO)**

**INTAKE (INDUCTION) IN(DOHC TURBO)**

**MECHANICAL ME(DOHC TURBO)**

**EXHAUST EX(DOHC TURBO)**

**IGNITION IG(DOHC TURBO)**

**ENGINE (DIAGNOSTICS) EN(DOHC TURBO)**

# MECHANICAL

# *ME(DOHC TURBO)*

---

|                                     | <b>Page</b> |
|-------------------------------------|-------------|
| 1. General Description .....        | 2           |
| 2. Compression .....                | 22          |
| 3. Idle Speed .....                 | 23          |
| 4. Ignition Timing .....            | 24          |
| 5. Intake Manifold Vacuum.....      | 25          |
| 6. Engine Oil Pressure .....        | 26          |
| 7. Fuel Pressure .....              | 27          |
| 8. Valve Clearance.....             | 28          |
| 9. Engine Assembly .....            | 33          |
| 10. Engine Mounting .....           | 41          |
| 11. Preparation for Overhaul.....   | 42          |
| 12. V-belt.....                     | 43          |
| 13. Crankshaft Pulley .....         | 45          |
| 14. Belt Cover .....                | 46          |
| 15. Timing Belt Assembly.....       | 47          |
| 16. Camshaft Sprocket.....          | 56          |
| 17. Crankshaft Sprocket.....        | 57          |
| 18. Camshaft.....                   | 58          |
| 19. Cylinder Head Assembly.....     | 63          |
| 20. Cylinder Block .....            | 70          |
| 21. Engine Trouble in General ..... | 89          |
| 22. Engine Noise.....               | 94          |

# GENERAL DESCRIPTION

MECHANICAL

## 1. General Description

### A: SPECIFICATIONS

|                                    |   |          |   |          |
|------------------------------------|---|----------|---|----------|
| Engine                             | Type                                    |          | Horizontally opposed, liquid cooled, 4-cylinder, 4-stroke gasoline engine |          |
|                                    | Valve arrangement                       |          | Belt driven, double overhead camshaft, 4-valve/cylinder                   |          |
|                                    | Bore x Stroke                           |          | mm (in)   |          |
|                                    |   |          | 92 x 75 (3.62 x 2.95)   |          |
|                                    | Piston displacement                     |          | cm <sup>3</sup> (cu in)   |          |
|                                    |   |          | 1,994 (121.67)  |          |
|                                    | Compression ratio                       |          | 8.0   |          |
|                                    | Compression pressure (at 200 — 300 rpm) |          | kPa (kgf/cm <sup>2</sup> , psi)   |          |
|                                    |   |          | 981 — 1,177 (10 — 12, 142 — 171)  |          |
|                                    | Number of piston rings                  |          | Pressure ring: 2, Oil ring: 1   |          |
|                                    | Intake valve timing                     |          | Opening   | 10° BTDC |
|                                    |   |          | Closing   | 50° ABDC |
|                                    | Exhaust valve timing                    |          | Opening   | 53° BBDC |
|                                    |   |          | Closing   | 7° ATDC  |
|                                    | Valve clearance                         |          | Intake  | mm (in)  |
| Exhaust                            |   |          | mm (in)   |          |
|                                    |   |          | 0.20±0.02 (0.0079±0.0008)   |          |
|                                    |   |          | 0.25±0.02 (0.0098±0.0008)   |          |
| Idling speed [At neutral position] |   | rpm      | 750±100 (No load)<br>800±150 (A/C switch ON)                              |          |
| Firing order                       |   |          | 1 → 3 → 2 → 4   |          |
| Ignition timing                    |   | BTDC/rpm | 12°±3°/750 rpm  |          |

NOTE:

STD: Standard I.D.: Inner Diameter O.D.: Outer Diameter OS: Oversize US: Undersize

# GENERAL DESCRIPTION

MECHANICAL

|                       |                                   |                     |   |   |
|-----------------------|-----------------------------------|---------------------|---|---|
| Belt tension adjuster | Protrusion of adjuster rod        |                     | 5.2 — 6.2 mm (0.205 — 0.244 in)   |   |
| Belt tensioner        | Spacer O.D.                       |                     | 17.955 — 17.975 mm (0.7069 — 0.7077 in)   |   |
|                       | Tensioner bush I.D.               |                     | 18.0 — 18.08 mm (0.7087 — 0.7118 in)  |   |
|                       | Clearance between spacer and bush | STD                 | 0.025 — 0.125 mm (0.0010 — 0.0049 in)   |   |
|                       |                                   | Limit               | 0.175 mm (0.0069 in)  |   |
|                       | Side clearance of spacer          | STD                 | 0.2 — 0.55 mm (0.0079 — 0.0217 in)  |   |
| Limit                 |                                   | 0.81 mm (0.0319 in) |   |   |
| Camshaft              | Bend limit                        |                     | 0.020 mm (0.0079 in)  |   |
|                       | Thrust clearance                  | STD                 | 0.015 — 0.070 mm (0.0006 — 0.0028 in)   |   |
|                       |                                   | Limit               | 0.10 mm (0.0039 in)   |   |
|                       | Cam lobe height                   | Intake              | STD   | 46.25 — 46.35 mm (1.821 — 1.825 in)     |
|                       |                                   |                     | Limit   | 46.15 mm (1.817 in)                     |
|                       |                                   | Exhaust             | STD   | 46.15 — 46.25 mm (1.817 — 1.821 in)     |
|                       |                                   |                     | Limit   | 46.05 mm (1.813 in)                     |
|                       | Journal O.D.                      | STD                 | Front   | 37.946 — 37.963 mm (1.4939 — 1.4946 in) |
|                       |                                   |                     | Center rear   | 29.946 — 29.963 mm (1.1790 — 1.1796 in) |
|                       | Oil clearance                     | STD                 | 0.037 — 0.072 mm (0.0015 — 0.0028 in)   |   |
| Limit                 |                                   | 0.10 mm (0.0039 in) |   |   |
| Cylinder head         | Surface warpage limit             |                     | 0.05 mm (0.0020 in)   |   |
|                       | Surface grinding limit            |                     | 0.3 mm (0.012 in)   |   |
|                       | Standard height                   |                     | 127.5 mm (5.02 in)  |   |
| Valve seat            | Refacing angle                    |                     | 90°   |   |
|                       | Contacting width                  | Intake              | STD   | 1.0 mm (0.039 in)                       |
|                       |                                   |                     | Limit   | 1.7 mm (0.067 in)                       |
|                       |                                   | Exhaust             | STD   | 1.5 mm (0.059 in)                       |
|                       |                                   |                     | Limit   | 2.2 mm (0.087 in)                       |
| Valve guide           | Inner diameter                    |                     | 6.000 — 6.015 mm (0.2362 — 0.2368 in)   |   |
|                       | Protrusion above head             |                     | 12.0 — 12.4 mm (0.472 — 0.488 in)   |   |
| Valve                 | Head edge thickness               | Intake              | STD   | 1.2 mm (0.047 in)                       |
|                       |                                   |                     | Limit   | 0.8 mm (0.031 in)                       |
|                       |                                   | Exhaust             | STD   | 1.5 mm (0.059 in)                       |
|                       |                                   |                     | Limit   | 0.8 mm (0.031 in)                       |
|                       | Stem diameter                     | Intake              | 5.950 — 5.965 mm (0.2343 — 0.2348 in)   |   |
|                       |                                   | Exhaust             | 5.950 — 5.965 mm (0.2343 — 0.2348 in)   |   |
|                       | Stem oil clearance                | STD                 | Intake  | 0.035 — 0.062 mm (0.0014 — 0.0024 in)   |
|                       |                                   |                     | Exhaust   | 0.040 — 0.067 mm (0.0016 — 0.0026 in)   |
| Overall length        | Limit                             | —                   | 0.15 mm (0.0059 in)   |   |
|                       |                                   | Intake              | 104.4 mm (4.110 in)   |   |
| Valve spring          | Free length                       |                     | 44.67 mm (1.7587 in)  |   |
|                       | Squareness                        |                     | 2.5°, 2.0 mm (0.079 in)   |   |
|                       | Tension/spring height             |                     | 220.7±15.7 N (22.5±1.6 kgf, 49.6±3.5 lb)/36.0 mm (1.417 in)<br>510.9±25.5 N (52.1±2.6 kgf, 114.9±5.7 lb)/26.6 mm (1.047 in) |   |

# GENERAL DESCRIPTION

## MECHANICAL

|                          |  |                        |                                       |  |
|--------------------------|--|------------------------|---------------------------------------|--|
| Cylinder block           | Surface warpage limit (mating with cylinder head)        |                        | 0.05 mm (0.0020 in)                   |  |
|                          | Surface grinding limit                                   |                        | 0.1 mm (0.004 in)                     |  |
|                          | Cylinder bore  | STD                    | A                                     | 92.005 — 92.015 mm (3.6222 — 3.6226 in)                            |
|                          |  |                        | B                                     | 91.995 — 92.005 mm (3.6218 — 3.6222 in)                            |
|                          | Taper  | STD                    |                                       | 0.015 mm (0.0006 in)   |
|                          |  | Limit                  |                                       | 0.050 mm (0.0020 in)   |
|                          | Out-of-roundness   | STD                    |                                       | 0.010 mm (0.0004 in)   |
|                          |  | Limit                  |                                       | 0.050 mm (0.0020 in)   |
| Piston clearance         | STD  |                        | 0.010 — 0.030 mm (0.0004 — 0.0012 in) |  |
|                          | Limit  |                        | 0.050 mm (0.0020 in)                  |  |
| Enlarging (boring) limit |  |                        | 0.5 mm (0.020 in)                     |  |
| Piston                   | Outer diameter   | STD                    | A                                     | 91.985 — 91.995 mm (3.6214 — 3.6218 in)                            |
|                          |  |                        | B                                     | 91.975 — 91.985 mm (3.6211 — 3.6214 in)                            |
|                          |  | 0.25 mm (0.0098 in) OS |                                       | 92.225 — 92.235 mm (3.6309 — 3.6313 in)                            |
|                          |  | 0.50 mm (0.0197 in) OS |                                       | 92.475 — 92.485 mm (3.6407 — 3.6411 in)                            |
| Piston pin               | Standard clearance between piston pin and hole in piston |                        | STD                                   | 0.004 — 0.008 mm (0.0002 — 0.0003 in)                              |
|                          |  |                        | Limit                                 | 0.020 mm (0.0008 in)   |
|                          | Degree of fit  |                        |                                       | Piston pin must be fitted into position with thumb at 20°C (68°F). |
| Piston ring              | Piston ring gap  | Top ring               | STD                                   | 0.20 — 0.26 mm (0.0079 — 0.0102 in)                                |
|                          |  |                        | Limit                                 | 1.0 mm (0.039 in)  |
|                          |  | Second ring            | STD                                   | 0.35 — 0.50 mm (0.0138 — 0.0197 in)                                |
|                          |  |                        | Limit                                 | 1.0 mm (0.039 in)  |
|                          | Oil ring   | STD                    | 0.20 — 0.70 mm (0.0079 — 0.0276 in)   |  |
|                          |  | Limit                  | 1.5 mm (0.059 in)                     |  |
|                          | Clearance between piston ring and piston ring groove     | Top ring               | STD                                   | 0.040 — 0.080 mm (0.0016 — 0.0031 in)                              |
|                          |  |                        | Limit                                 | 0.15 mm (0.0059 in)  |
| Second ring              |  | STD                    | 0.030 — 0.070 mm (0.0012 — 0.0028 in) |  |
|                          |  | Limit                  | 0.15 mm (0.0059 in)                   |  |
| Connecting rod           | Bend twist per 100 mm (3.94 in) in length                |                        | Limit                                 | 0.10 mm (0.0039 in)  |
|                          | Side clearance   | STD                    |                                       | 0.070 — 0.330 mm (0.0028 — 0.0130 in)                              |
|                          |  | Limit                  |                                       | 0.4 mm (0.016 in)  |
| Connecting rod bearing   | Oil clearance  |                        | STD                                   | 0.020 — 0.046 mm (0.0008 — 0.0018 in)                              |
|                          |  |                        | Limit                                 | 0.05 mm (0.0020 in)  |
|                          | Thickness at center portion                              | STD                    |                                       | 1.492 — 1.501 mm (0.0587 — 0.0591 in)                              |
|                          |  | 0.03 mm (0.0012 in) US |                                       | 1.510 — 1.513 mm (0.0594 — 0.0596 in)                              |
|                          |  | 0.05 mm (0.0020 in) US |                                       | 1.520 — 1.523 mm (0.0598 — 0.0600 in)                              |
|                          |  | 0.25 mm (0.0098 in) US |                                       | 1.620 — 1.623 mm (0.0638 — 0.0639 in)                              |
| Connecting rod bushing   | Clearance between piston pin and bushing                 |                        | STD                                   | 0 — 0.022 mm (0 — 0.0009 in)                                       |
|                          |  |                        | Limit                                 | 0.030 mm (0.0012 in)   |

# GENERAL DESCRIPTION

MECHANICAL

|                    |                              |                        |                                       |   |
|--------------------|------------------------------|------------------------|---------------------------------------|---|
| Crankshaft         | Bend limit                   |                        | 0.035 mm (0.0014 in)                  |   |
|                    | Crank pin and crank journal  | Out-of-roundness       |                                       | 0.020 mm (0.0008 in) or less            |
|                    |                              | Grinding limit         |                                       | 0.25 mm (0.0098 in)                     |
|                    | Crank pin outer diameter     | STD                    |                                       | 47.954 — 48.000 mm (1.8879 — 1.8898)    |
|                    |                              | 0.03 mm (0.0012 in) US |                                       | 47.954 — 47.970 mm (1.8879 — 1.8886)    |
|                    |                              | 0.05 mm (0.0020 in) US |                                       | 47.934 — 47.950 mm (1.8872 — 1.8878)    |
|                    |                              | 0.25 mm (0.0098 in) US |                                       | 47.734 — 47.750 mm (1.8793 — 1.8799)    |
|                    | Crank journal outer diameter | #1, #3, #5             | STD                                   | 59.992 — 60.008 mm (2.3619 — 2.3625 in) |
|                    |                              |                        | 0.03 mm (0.0012 in) US                | 59.962 — 59.978 mm (2.3607 — 2.3613 in) |
|                    |                              |                        | 0.05 mm (0.0020 in) US                | 59.942 — 59.958 mm (2.3599 — 2.3605 in) |
|                    |                              |                        | 0.25 mm (0.0098 in) US                | 59.742 — 59.758 mm (2.3520 — 2.3527 in) |
|                    |                              | #2, #4                 | STD                                   | 59.992 — 60.008 mm (2.3619 — 2.3625 in) |
|                    |                              |                        | 0.03 mm (0.0012 in) US                | 59.962 — 59.978 mm (2.3607 — 2.3613 in) |
|                    |                              |                        | 0.05 mm (0.0020 in) US                | 59.942 — 59.958 mm (2.3599 — 2.3605 in) |
|                    |                              |                        | 0.25 mm (0.0098 in) US                | 59.742 — 59.758 mm (2.3520 — 2.3527 in) |
| Thrust clearance   |                              | STD                    | 0.030 — 0.115 mm (0.0012 — 0.0045 in) |   |
|                    |                              | Limit                  | 0.25 mm (0.0098 in)                   |   |
| Oil clearance      |                              | STD                    | 0.010 — 0.030 mm (0.0004 — 0.0012 in) |   |
|                    |                              | Limit                  | 0.040 mm (0.0016 in)                  |   |
| Crankshaft bearing | Crankshaft bearing thickness | #1, #3                 | STD                                   | 1.998 — 2.011 mm (0.0787 — 0.0792 in)   |
|                    |                              |                        | 0.03 mm (0.0012 in) US                | 2.017 — 2.020 mm (0.0794 — 0.0795 in)   |
|                    |                              |                        | 0.05 mm (0.0020 in) US                | 2.027 — 2.030 mm (0.0798 — 0.0799 in)   |
|                    |                              |                        | 0.25 mm (0.0098 in) US                | 2.127 — 2.130 mm (0.0837 — 0.0839 in)   |
|                    |                              | #2, #4, #5             | STD                                   | 2.000 — 2.013 mm (0.0787 — 0.0793 in)   |
|                    |                              |                        | 0.03 mm (0.0012 in) US                | 2.019 — 2.022 mm (0.0795 — 0.0796 in)   |
|                    |                              |                        | 0.05 mm (0.0020 in) US                | 2.029 — 2.032 mm (0.0799 — 0.0800 in)   |
|                    |                              |                        | 0.25 mm (0.0098 in) US                | 2.129 — 2.132 mm (0.0838 — 0.0839 in)   |

**ME(DOHC TURBO)-5**

# GENERAL DESCRIPTION

MECHANICAL

## B: COMPONENT

### 1. TIMING BELT

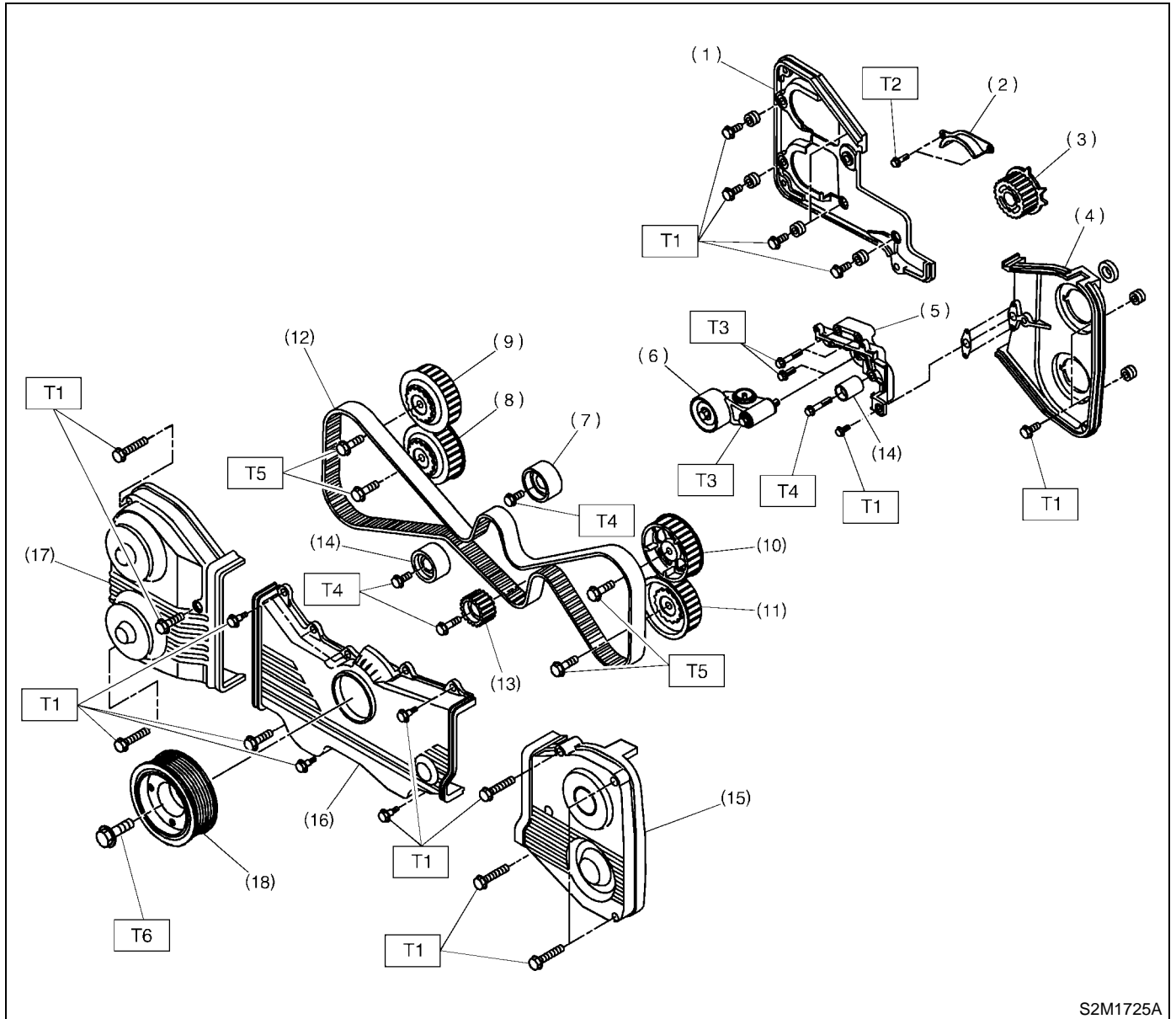

S2M1725A

- |  |  |                            |
|--|--|----------------------------|
| (1) Right-hand belt cover No. 2          | (9) Right-hand intake camshaft sprocket  | (17) Right-hand belt cover |
| (2) Timing belt guide (MT vehicles only) | (10) Left-hand intake camshaft sprocket  | (18) Crankshaft pulley     |
| (3) Crankshaft sprocket                  | (11) Left-hand exhaust camshaft sprocket |                            |
| (4) Left-hand belt cover No. 2           | (12) Timing belt                         |                            |
| (5) Tensioner bracket                    | (13) Belt idler No. 2                    |                            |
| (6) Automatic belt tension adjuster ASSY | (14) Belt idler                          |                            |
| (7) Belt idler                           | (15) Left-hand belt cover                |                            |
| (8) Right-hand exhaust camshaft sprocket | (16) Front belt cover                    |                            |

#### **Tightening torque: N·m (kgf-m, ft-lb)**

**T1: 5 (0.5, 3.6)**

**T2: 10 (1.0, 7)**

**T3: 25 (2.5, 18.1)**

**T4: 39 (4.0, 28.9)**

**T5: 98 (10, 72.4)**

**T6: 127 (13, 94.0)**





# GENERAL DESCRIPTION

MECHANICAL

## 2. CYLINDER HEAD AND CAMSHAFT

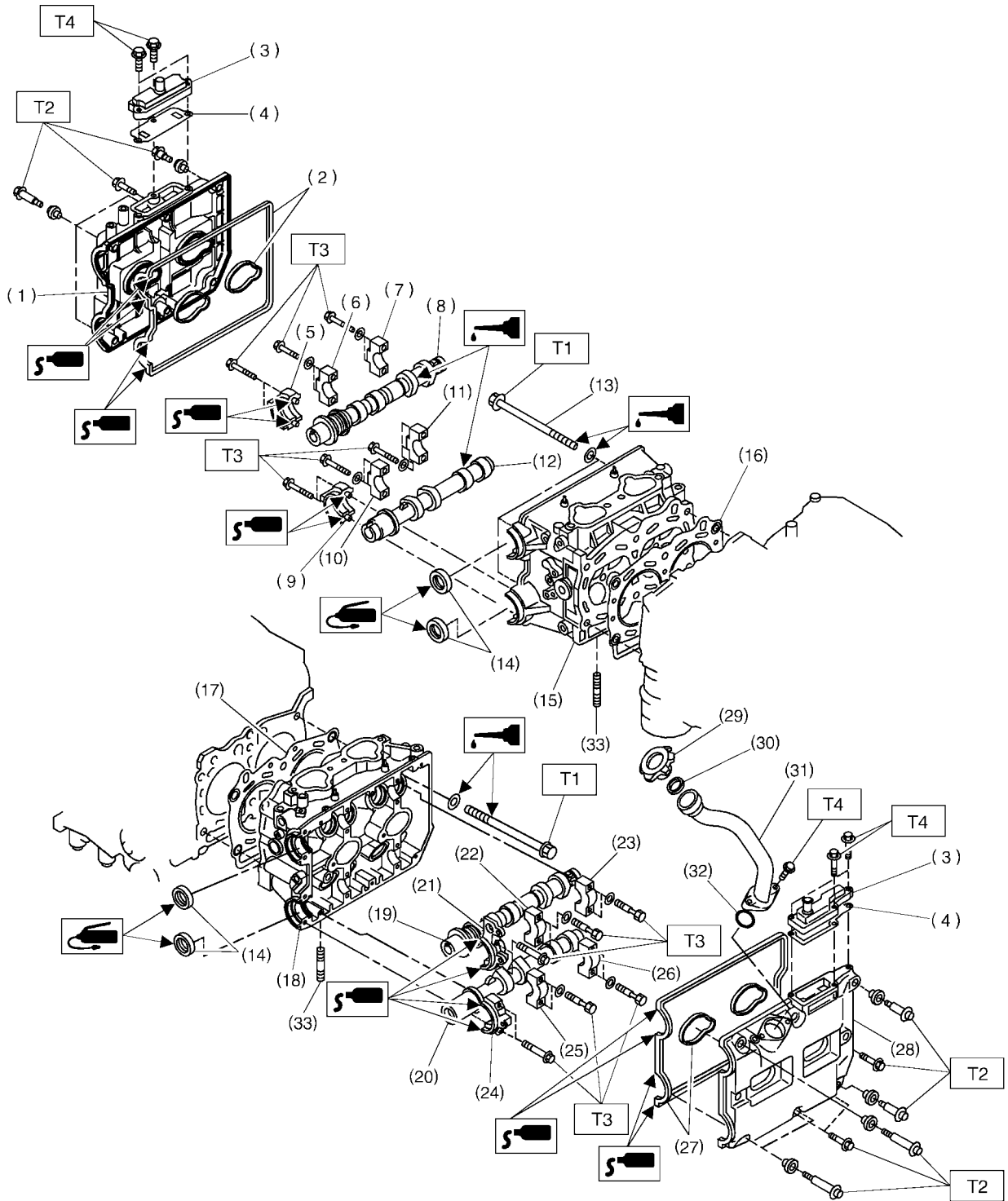

S2M1188A

ME(DOHC TURBO)-8

# GENERAL DESCRIPTION

MECHANICAL

- |                                       |                                       |                      |
|---------------------------------------|---------------------------------------|----------------------|
| (1) Rocker cover (RH)                 | (15) Cylinder head (RH)               | (29) Oil filler cap  |
| (2) Rocker cover gasket (RH)          | (16) Cylinder head gasket (RH)        | (30) Gasket          |
| (3) Oil separator cover               | (17) Cylinder head gasket (LH)        | (31) Oil filler duct |
| (4) Gasket                            | (18) Cylinder head (LH)               | (32) O-ring          |
| (5) Intake camshaft cap (Front RH)    | (19) Intake camshaft (LH)             | (33) Stud bolt       |
| (6) Intake camshaft cap (Center RH)   | (20) Exhaust camshaft (LH)            |                      |
| (7) Intake camshaft cap (Rear RH)     | (21) Intake camshaft cap (Front LH)   |                      |
| (8) Intake camshaft (RH)              | (22) Intake camshaft cap (Center LH)  |                      |
| (9) Exhaust camshaft cap (Front RH)   | (23) Intake camshaft cap (Rear LH)    |                      |
| (10) Exhaust camshaft cap (Center RH) | (24) Exhaust camshaft (Front LH)      |                      |
| (11) Exhaust camshaft cap (Rear RH)   | (25) Exhaust camshaft cap (Center LH) |                      |
| (12) Exhaust camshaft (RH)            | (26) Exhaust camshaft cap (Rear LH)   |                      |
| (13) Cylinder head bolt               | (27) Rocker cover gasket (LH)         |                      |
| (14) Oil seal                         | (28) Rocker cover (LH)                |                      |

---

**Tightening torque: N·m (kgf-m, ft-lb)**

**T1: <Ref. to ME(DOHC TURBO)-63, Installation, Cylinder Head Assembly.>**

**T2: 5 (0.5, 3.6)**

**T3: 10 (1.0, 7)**

**T4: 6.4 (0.65, 4.7)**

---

# GENERAL DESCRIPTION

MECHANICAL

## 3. CYLINDER HEAD AND VALVE ASSEMBLY

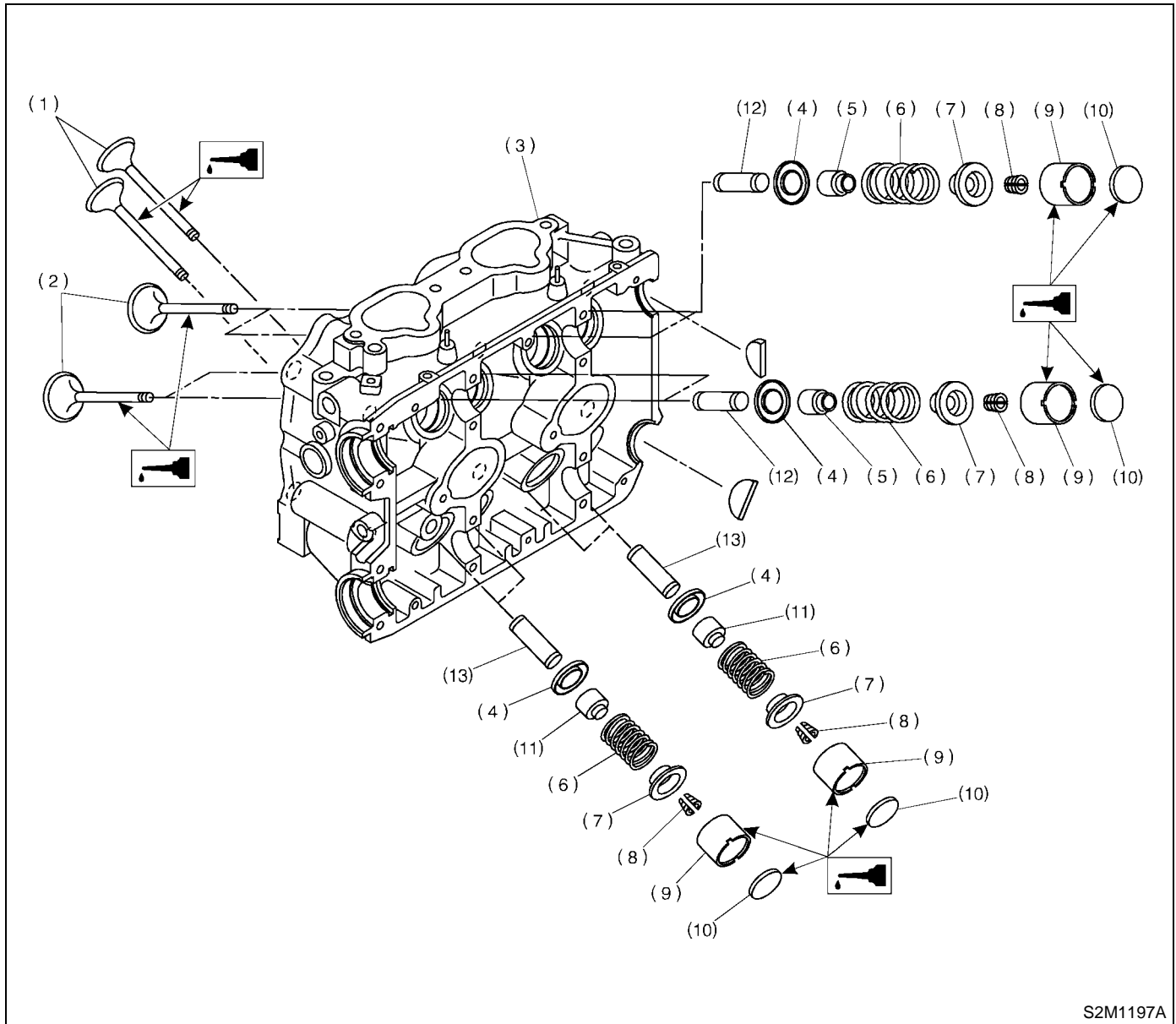

S2M1197A

- |                           |                  |                             |
|---------------------------|------------------|-----------------------------|
| (1) Exhaust valve         | (6) Valve spring | (11) Exhaust valve oil seal |
| (2) Intake valve          | (7) Retainer     | (12) Intake valve guide     |
| (3) Cylinder head         | (8) Retainer key | (13) Exhaust valve guide    |
| (4) Valve spring seat     | (9) Valve lifter |                             |
| (5) Intake valve oil seal | (10) Shim        |                             |

## 4. CYLINDER BLOCK

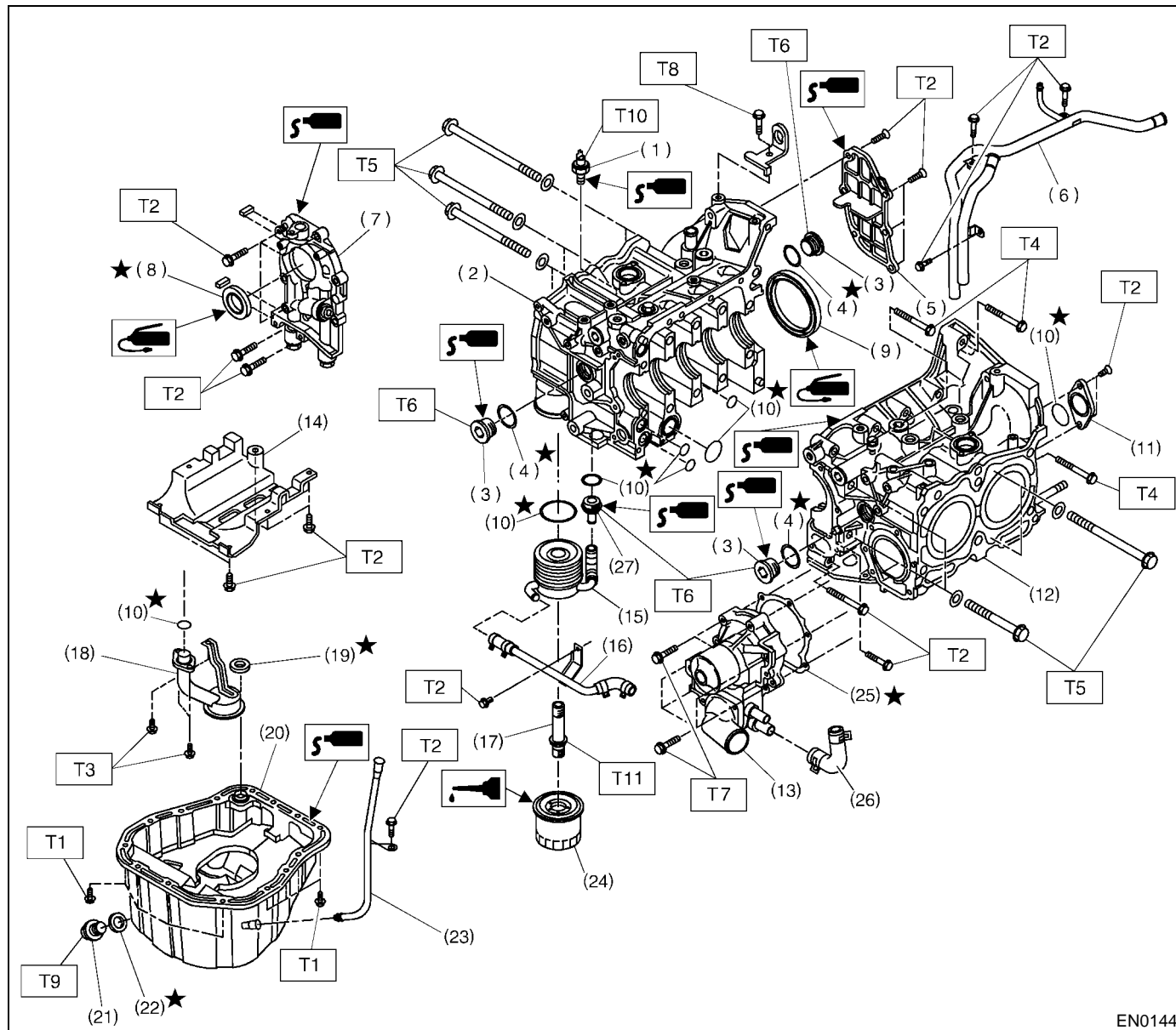

EN0144

- |                          |                            |
|--------------------------|----------------------------|
| (1) Oil pressure switch  | (15) Oil cooler            |
| (2) Cylinder block (RH)  | (16) Waster by-pass pipe   |
| (3) Service hole plug    | (17) Connector             |
| (4) Gasket               | (18) Oil strainer          |
| (5) Oil separator cover  | (19) Gasket                |
| (6) Water by-pass pipe   | (20) Oil pan               |
| (7) Oil pump             | (21) Drain plug            |
| (8) Front oil seal       | (22) Metal gasket          |
| (9) Rear oil seal        | (23) Oil level gauge guide |
| (10) O-ring              | (24) Oil filter            |
| (11) Service hole cover  | (25) Gasket                |
| (12) Cylinder block (LH) | (26) Water pump hose       |
| (13) Water pump          | (27) Plug                  |
| (14) Baffle plate        |                            |

### Tightening torque: N·m (kgf·m, ft·lb)

- |             |                             |
|-------------|-----------------------------|
| <b>T1:</b>  | <b>5 (0.5, 3.6)</b>         |
| <b>T2:</b>  | <b>6.4 (0.65, 4.7)</b>      |
| <b>T3:</b>  | <b>10 (1.0, 7)</b>          |
| <b>T4:</b>  | <b>25 (2.5, 18.1)</b>       |
| <b>T5:</b>  | <b>47 (4.8, 34.7)</b>       |
| <b>T6:</b>  | <b>69 (7.0, 50.6)</b>       |
| <b>T7:</b>  | <b>First 12 (1.2, 8.7)</b>  |
|             | <b>Second 12 (1.2, 8.7)</b> |
| <b>T8:</b>  | <b>16 (1.6, 11.6)</b>       |
| <b>T9:</b>  | <b>44 (4.5, 33)</b>         |
| <b>T10:</b> | <b>25 (2.5, 18.1)</b>       |
| <b>T11:</b> | <b>55 (5.5, 40)</b>         |

# GENERAL DESCRIPTION

MECHANICAL

## 5. CRANKSHAFT AND PISTON

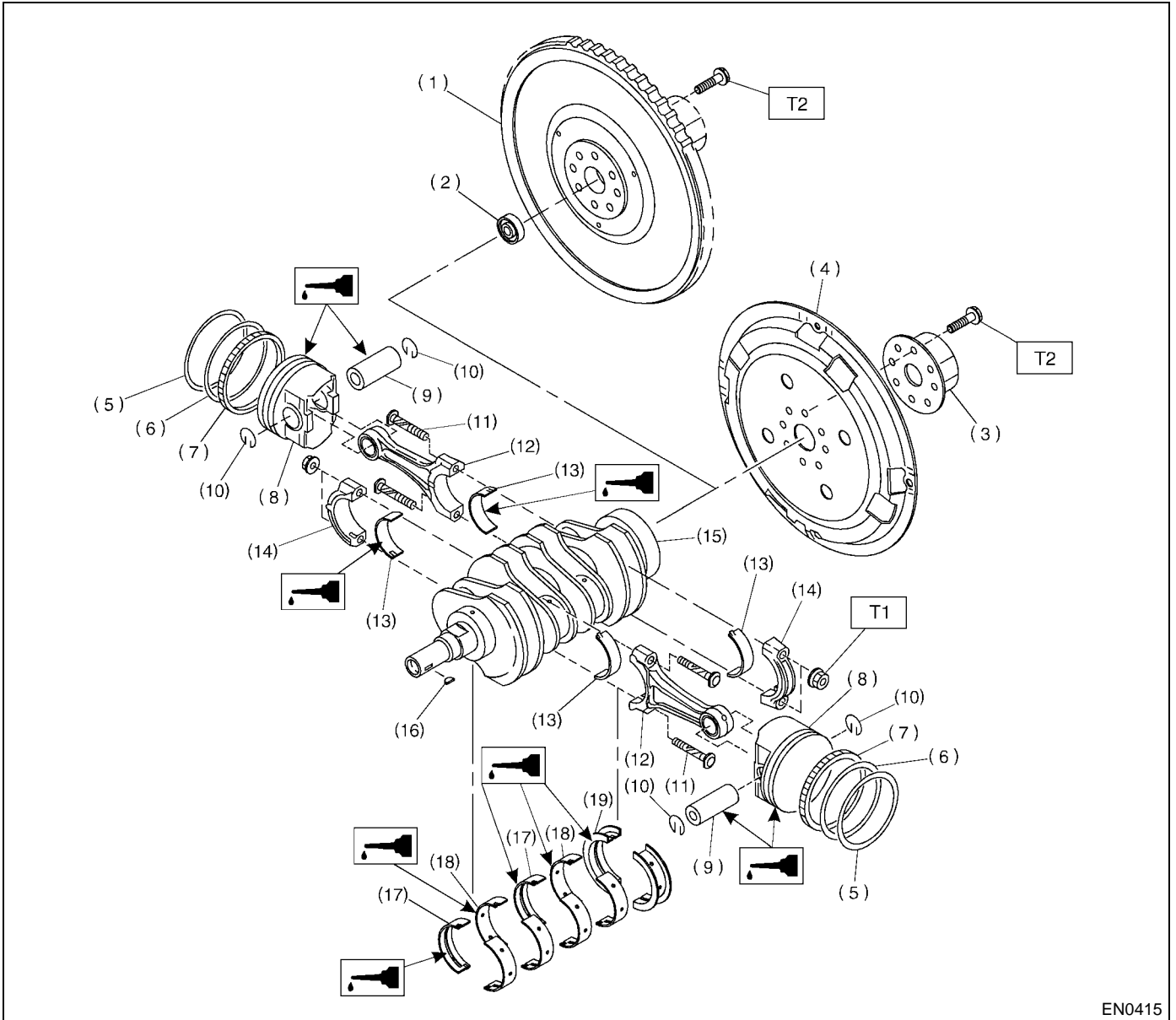

EN0415

- |                                      |                             |                                |
|--------------------------------------|-----------------------------|--------------------------------|
| (1) Flywheel (MT vehicles only)      | (9) Piston pin              | (17) Crankshaft bearing #1, #3 |
| (2) Ball bearing (MT vehicles only)  | (10) Circlip                | (18) Crankshaft bearing #2, #4 |
| (3) Reinforcement (AT vehicles only) | (11) Connecting rod bolt    | (19) Crankshaft bearing #5     |
| (4) Drive plate (AT vehicles only)   | (12) Connecting rod         |                                |
| (5) Top ring                         | (13) Connecting rod bearing |                                |
| (6) Second ring                      | (14) Connecting rod cap     |                                |
| (7) Oil ring                         | (15) Crankshaft             |                                |
| (8) Piston                           | (16) Woodruff key           |                                |

**Tightening torque: N·m (kgf·m, ft·lb)**

**T1: 44.6 (4.55, 32.9)**

**T2: 72 (7.3, 52.8)**

**ME(DOHC TURBO)-12**

6. ENGINE MOUNTING

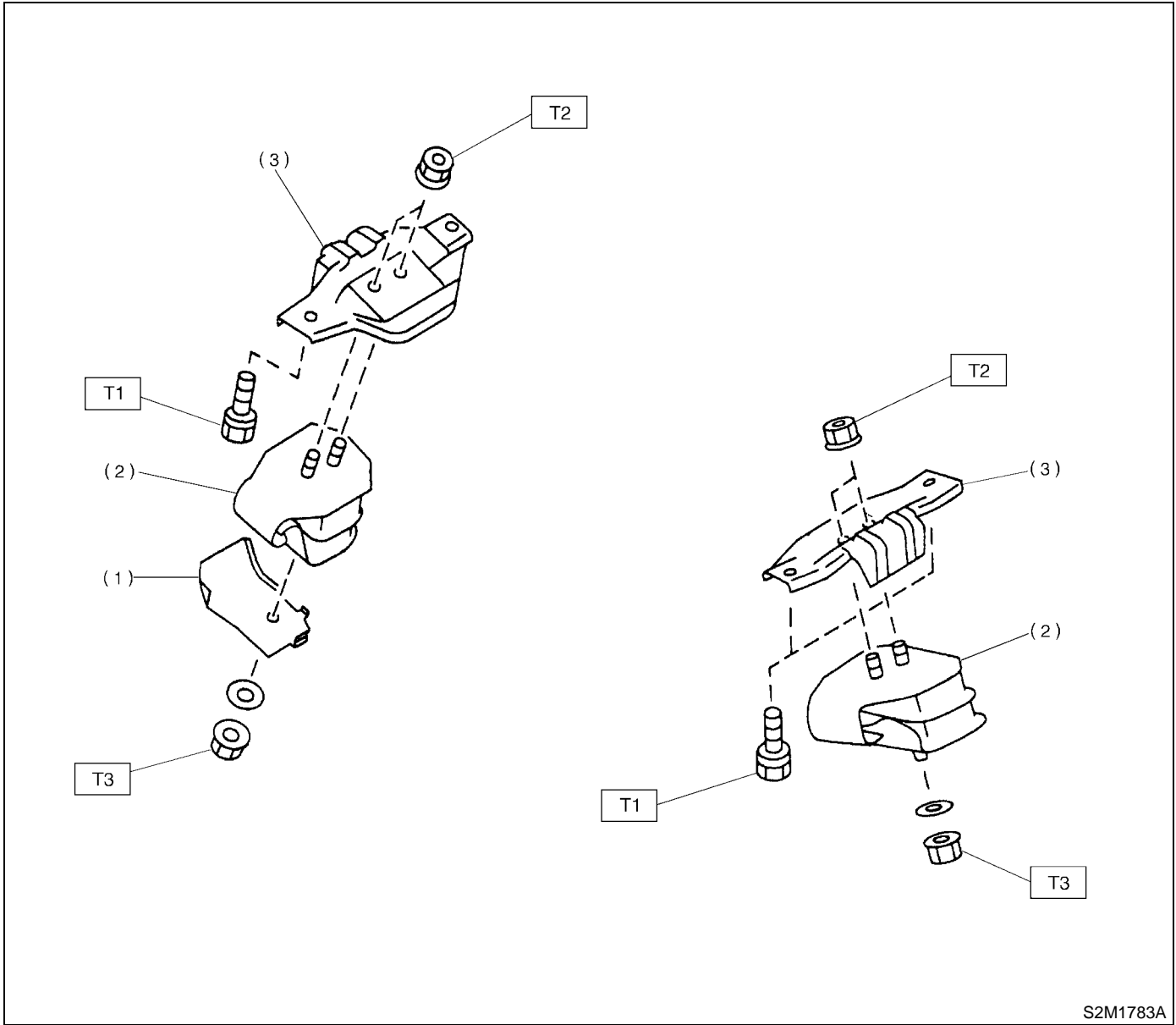

S2M1783A

- (1) Hear shield cover
- (2) Front cushion rubber

- (3) Front engine mounting bracket

**Tightening torque: N·m (kgf·m, ft·lb)**

**T1: 35 (3.6, 25.8)**

**T2: 42 (4.3, 30.9)**

**T3: 85 (8.7, 62.7)**

# GENERAL DESCRIPTION

## MECHANICAL

### C: CAUTION

- Wear working clothing, including a cap, protective goggles, and protective shoes during operation.
- Remove contamination including dirt and corrosion before removal, installation or disassembly.
- Keep the disassembled parts in order and protect them from dust or dirt.
- Before removal, installation or disassembly, be sure to clarify the failure. Avoid unnecessary removal, installation, disassembly, and replacement.
- Be careful not to burn your hands, because each part in the vehicle is hot after running.
- Be sure to tighten fasteners including bolts and nuts to the specified torque.
- Place shop jacks or safety stands at the specified points.
- Before disconnecting electrical connectors of sensors or units, be sure to disconnect negative terminal from battery.
- All parts should be thoroughly cleaned, paying special attention to the engine oil passages, pistons and bearings.

- Rotating parts and sliding parts such as piston, bearing and gear should be coated with oil prior to assembly.
- Be careful not to let oil, grease or coolant contact the timing belt, clutch disc and flywheel.
- All removed parts, if to be reused, should be re-installed in the original positions and directions.
- Bolts, nuts and washers should be replaced with new ones as required.
- Even if necessary inspections have been made in advance, proceed with assembly work while making rechecks.
- Remove or install engine in an area where chain hoists, lifting devices, etc. are available for ready use.
- Be sure not to damage coated surfaces of body panels with tools or stain seats and windows with coolant or oil. Place a cover over fenders, as required, for protection.
- Prior to starting work, prepare the following:  
Service tools, clean cloth, containers to catch coolant and oil, wire ropes, chain hoist, transmission jacks, etc.
- Lift-up or lower the vehicle when necessary. Make sure to support the correct positions.

### D: PREPARATION TOOL

#### 1. SPECIAL TOOLS

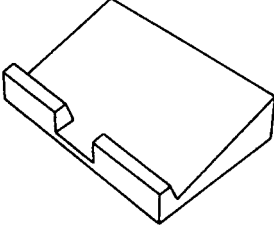
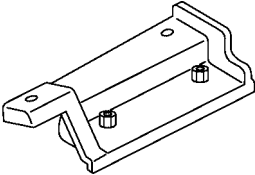
| ILLUSTRATION  | TOOL NUMBER | DESCRIPTION             | REMARKS   |
|---|-------------|-------------------------|---|
|  <p style="text-align: right;">EN0147</p>  | 498267600   | CYLINDER HEAD TABLE     | <ul style="list-style-type: none"> <li>• Used for replacing valve guides.</li> <li>• Used for removing and installing valve springs.</li> </ul> |
|  <p style="text-align: right;">B2M3851</p> | 498457000   | ENGINE STAND ADAPTER RH | Used with ENGINE STAND (499817000).   |

# GENERAL DESCRIPTION

MECHANICAL

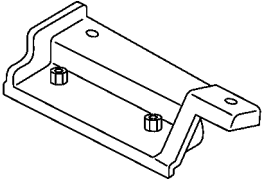
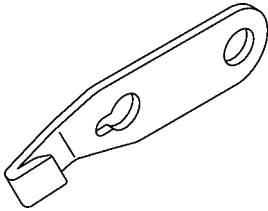
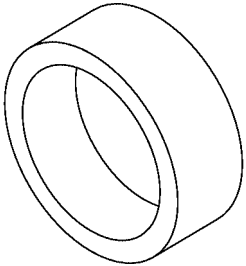
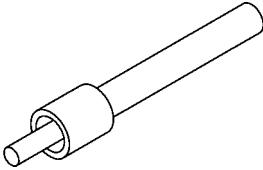
| ILLUSTRATION  | TOOL NUMBER | DESCRIPTION             | REMARKS   |
|---|-------------|-------------------------|---|
|  <p style="text-align: right;">B2M3852</p>   | 498457100   | ENGINE STAND ADAPTER LH | Used with ENGINE STAND (499817000).   |
|  <p style="text-align: right;">B2M3853</p>   | 498497100   | CRANKSHAFT STOPPER      | Used for stopping rotation of flywheel when loosening and tightening crankshaft pulley bolt, etc. |
|  <p style="text-align: right;">B2M3854</p> | 398744300   | PISTON GUIDE            | Used for installing piston in cylinder.   |
|  <p style="text-align: right;">B2M3855</p> | 498857100   | VALVE OIL SEAL GUIDE    | Used for press-fitting of intake and exhaust valve guide oil seals.                               |



# GENERAL DESCRIPTION

MECHANICAL

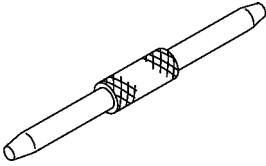
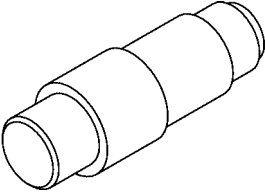
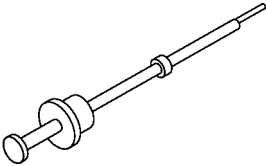
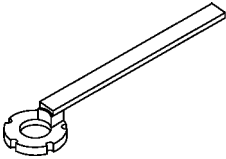
| ILLUSTRATION  | TOOL NUMBER | DESCRIPTION                                | REMARKS  |
|---|-------------|--|--|
|  <p style="text-align: right;">B2M3856</p>   | 499017100   | PISTON PIN GUIDE                           | Used for installing piston pin, piston and connecting rod. |
|  <p style="text-align: right;">B2M3857</p>   | 499037100   | CONNECTING ROD BUSHING REMOVER & INSTALLER | Used for removing and installing connecting rod bushing.   |
|  <p style="text-align: right;">B2M3858</p> | 499097700   | PISTON PIN REMOVER ASSY                    | Used for removing piston pin.                              |
|  <p style="text-align: right;">B2M4158</p> | 499207400   | CAMSHAFT SPROCKET WRENCH                   | Used for removing and installing camshaft sprocket.        |

# GENERAL DESCRIPTION

MECHANICAL

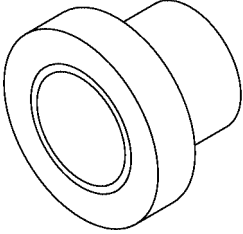
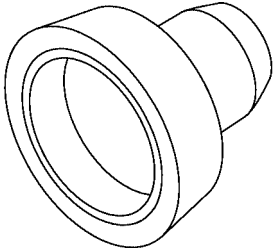
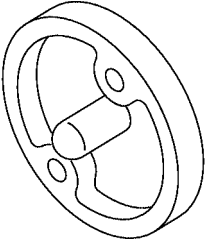
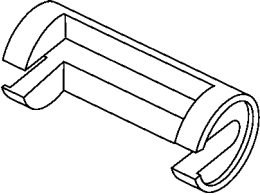
| ILLUSTRATION  | TOOL NUMBER | DESCRIPTION                   | REMARKS  |
|---|-------------|-------------------------------|--|
|  <p style="text-align: right;">B2M3860</p>   | 499587700   | CAMSHAFT OIL SEAL INSTALLER   | Used for installing cylinder head plug.  |
|  <p style="text-align: right;">B2M3861</p>   | 499587200   | CRANKSHAFT OIL SEAL INSTALLER | <ul style="list-style-type: none"> <li>• Used for installing crankshaft oil seal.</li> <li>• Used with CRANKSHAFT OIL SEAL GUIDE (499597100).</li> </ul>     |
|  <p style="text-align: right;">B2M3863</p> | 499597100   | CRANKSHAFT OIL SEAL GUIDE     | <ul style="list-style-type: none"> <li>• Used for installing crankshaft oil seal.</li> <li>• Used with CRANKSHAFT OIL SEAL INSTALLER (499587200).</li> </ul> |
|  <p style="text-align: right;">B2M3864</p> | 499718000   | VALVE SPRING REMOVER          | Used for removing and installing valve spring.   |

# GENERAL DESCRIPTION

MECHANICAL

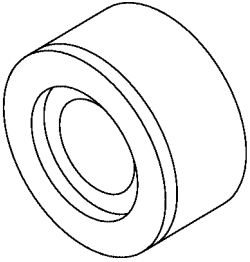
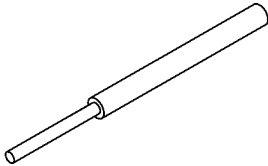
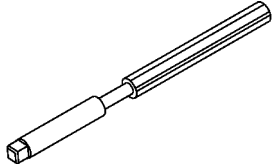
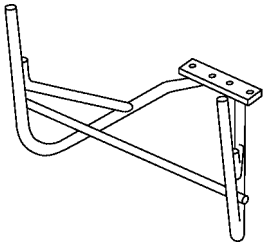
| ILLUSTRATION  | TOOL NUMBER | DESCRIPTION          | REMARKS  |
|---|-------------|----------------------|--|
|  <p style="text-align: right;">B2M3865</p>   | 498267700   | VALVE GUIDE ADJUSTER | Used for installing intake and exhaust valve guides.   |
|  <p style="text-align: right;">B2M3867</p>   | 499767200   | VALVE GUIDE REMOVER  | Used for removing valve guides.  |
|  <p style="text-align: right;">B2M3868</p> | 499767400   | VALVE GUIDE REAMER   | Used for reaming valve guides.   |
|  <p style="text-align: right;">B2M3869</p> | 499817000   | ENGINE STAND         | <ul style="list-style-type: none"> <li>• Stand used for engine disassembly and assembly.</li> <li>• Used with ENGINE STAND ADAPTER RH (498457000) &amp; LH (498457100).</li> </ul> |

# GENERAL DESCRIPTION

MECHANICAL

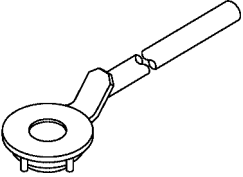
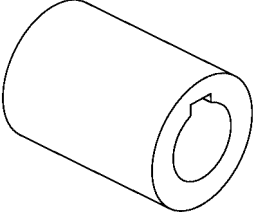
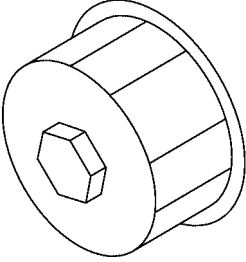
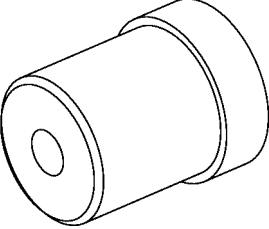
| ILLUSTRATION  | TOOL NUMBER | DESCRIPTION         | REMARKS  |
|---|-------------|---------------------|--|
|  <p style="text-align: right;">B2M4157</p>   | 499977300   | CRANK PULLEY WRENCH | Used for stopping rotation of crankshaft pulley when loosening and tightening crankshaft pulley bolts. |
|  <p style="text-align: right;">B2M3871</p>   | 499987500   | CRANKSHAFT SOCKET   | Used for rotating crankshaft.  |
|  <p style="text-align: right;">B2M3872</p> | 498547000   | OIL FILTER WRENCH   | Used for removing and installing oil filter.   |
|  <p style="text-align: right;">B2M3875</p> | 499587100   | OIL SEAL INSTALLER  | Used for installing oil pump oil seal.   |

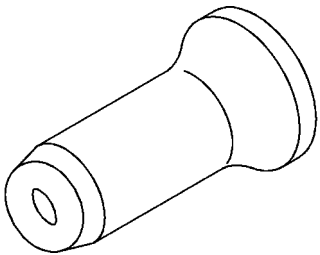
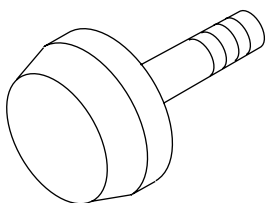
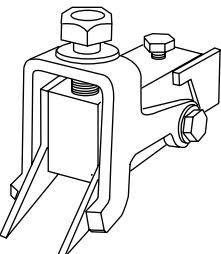

# GENERAL DESCRIPTION

MECHANICAL

| ILLUSTRATION   | TOOL NUMBER | DESCRIPTION      | REMARKS   |
|--|-------------|------------------|---|
|  <p style="text-align: right;">S1H0136</p>  | 499587600   | OIL SEAL GUIDE   | Used for installing camshaft oil seal.  |
|  <p style="text-align: right;">EN0168</p>   | 499597200   | OIL SEAL GUIDE   | <ul style="list-style-type: none"> <li>• Used for installing camshaft oil seal.</li> <li>• Used with OIL SEAL GUIDE (499587600).</li> </ul> |
|  <p style="text-align: right;">EN0169</p> | 49818200    | SHIM<br>REPLACER | Used for correct valve clearance.   |

# GENERAL DESCRIPTION

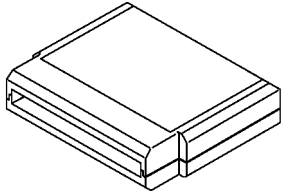
MECHANICAL

| ILLUSTRATION   | TOOL NUMBER | DESCRIPTION         | REMARKS  |
|--|-------------|---------------------|--|
|  <p>B2M3876</p> | 24082AA150  | CARTRIDGE           | Troubleshooting for electrical systems.  |
|  <p>B2M3877</p> | 22771AA030  | SELECT MONI-TOR KIT | Troubleshooting for electrical systems. <ul style="list-style-type: none"> <li>• English: 22771AA030 (Without printer)</li> <li>• German: 22771AA070 (Without printer)</li> <li>• French: 22771AA080 (Without printer)</li> <li>• Spanish: 22771AA090 (Without printer)</li> </ul> |

## 2. GENERAL PURPOSE TOOLS

| TOOL NAME         | REMARKS                             |
|-------------------|-------------------------------------|
| Compression Gauge | Used for measuring compression.     |
| Timing Light      | Used for measuring ignition timing. |

## E: PROCEDURE

It is possible to conduct the following service procedures with engine on the vehicle, however, the procedures described in this section are based on the condition that the engine is removed from the vehicle.

- V-belt
- Timing Belt
- Camshaft
- Cylinder Head

## 2. Compression

### A: INSPECTION

**CAUTION:**

After warming-up, engine becomes very hot. Be careful not to burn yourself during measurement.

- 1) After warming-up the engine, turn ignition switch to OFF.
- 2) Make sure that the battery is fully charged.
- 3) Release fuel pressure. <Ref. to FU(DOHC TURBO)-49, RELEASING OF FUEL PRESSURE, OPERATION, Fuel.>
- 4) Remove all the spark plugs. <Ref. to IG(DOHC TURBO)-4, REMOVAL, Spark Plug.>
- 5) Fully open throttle valve.
- 6) Check the starter motor for satisfactory performance and operation.
- 7) Hold the compression gauge tight against the spark plug hole.

**CAUTION:**

When using a screw-in type compression gauge, the screw (put into cylinder head spark plug hole) should be less than 18 mm (0.71 in) long.

- 8) Crank the engine by means of the starter motor, and read the maximum value on the gauge when the pointer is steady.

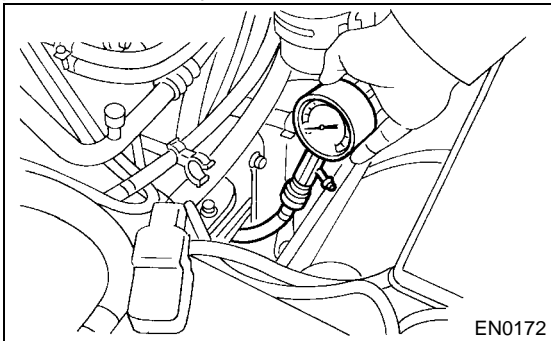

- 9) Perform at least two measurements per cylinder, and make sure that the values are correct.

**Compression (350 rpm and fully open throttle):**

**Standard;**

**951 — 1,147 kPa (9.7 — 11.7 kgf/cm<sup>2</sup>, 138 — 166 psi)**

**Limit;**

**834 kPa (8.5 kgf/cm<sup>2</sup>, 121 psi)**

**Difference between cylinders;**

**49 kPa (0.5 kgf/cm<sup>2</sup>, 7 psi)**

### 3. Idle Speed

#### A: INSPECTION

- 1) Before checking idle speed, check the following:
  - (1) Ensure that air cleaner element is free from clogging, ignition timing is correct, spark plugs are in good condition, and that hoses are connected properly.
  - (2) Ensure that malfunction indicator light (CHECK ENGINE light) does not illuminate.
- 2) Warm-up the engine.
- 3) Stop the engine, and turn ignition switch to OFF.
- 4) Insert the cartridge to SUBARU SELECT MONITOR.
- 5) Connect SUBARU SELECT MONITOR to the data link connector.
- 6) Turn ignition switch to ON, and SUBARU SELECT MONITOR switch to ON.
- 7) Select {2. Each System Check} in Main Menu.
- 8) Select {Engine Control System} in Selection Menu.
- 9) Select {1. Current Data Display & Save} in Engine Control System Diagnosis.
- 10) Select {1.12 Data Display} in Data Display Menu.
- 11) Start the engine, and read engine idle speed.
- 12) Check idle speed when unloaded. (With headlights, heater fan, rear defroster, radiator fan, air conditioning, etc. OFF)

***Idle speed (No load and gears in neutral:***

***750±100 rpm***

- 13) Check idle speed when loaded. (Turn air conditioning switch to "ON" and operate compressor for at least one minute before measurement.)

***Idle speed [A/C "ON", no load and gears in neutral]:***

***800±150 rpm***

**CAUTION:**

**Never rotate idle adjusting screw. If idle speed is out of specifications, refer to General On-board Diagnosis Table under "Engine Control System". <Ref. to EN(DOHC TURBO)-2, Basic Diagnostic Procedure.>**



## 4. Ignition Timing

### A: INSPECTION

- 1) Before checking ignition timing speed, check the following:
  - (1) Ensure that air cleaner element is free from clogging, spark plugs are in good condition, and that hoses are connected properly.
  - (2) Ensure that malfunction indicator light (CHECK ENGINE light) does not illuminate.
- 2) Warm-up the engine.
- 3) Stop the engine, and turn ignition switch to OFF.
- 4) Insert the cartridge to SUBARU SELECT MONITOR.
- 5) Connect SUBARU SELECT MONITOR to the data link connector.
- 6) Turn ignition switch to ON, and SUBARU SELECT MONITOR switch to ON.
- 7) Select {2. Each System Check} in Main Menu.
- 8) Select {Engine Control System} in Selection Menu.
- 9) Select {1. Current Data Display & Save} in Engine Control System Diagnosis.
- 10) Select {1.12 Data Display} in Data Display Menu.
- 11) Start the engine, at idle speed and check the ignition timing.

#### ***Ignition timing [BTDC/rpm]:***

***12°±3°/750***

If the timing is not correct, check the ignition control system. Refer to Engine Control System. <Ref. to EN(DOHC TURBO)-2, Basic Diagnostic Procedure.>

## 5. Intake Manifold Vacuum

### A: INSPECTION

- 1) Warm-up the engine.
- 2) Disconnect the brake vacuum hose and install the vacuum gauge to the hose fitting on the manifold.

3) Keep the engine at the idle speed and read the vacuum gauge indication.

By observing the gauge needle movement, the internal condition of the engine can be diagnosed as described below.

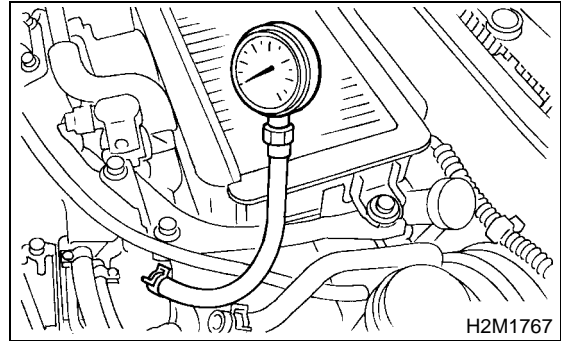

**Vacuum pressure (at idling, A/C "OFF"):**  
**Less than -60.0 kPa (-450 mmHg, -17.72 in-Hg)**

| <b>Diagnosis of engine condition by measurement of manifold vacuum</b>  |   |
|---|---|
| Vacuum gauge indication   | Possible engine condition   |
| 1. Needle is steady but lower than normal position. This tendency becomes more evident as engine temperature rises.                                     | Leakage around intake manifold gasket or disconnection or damaged vacuum hose |
| 2. When engine speed is reduced slowly from higher speed, needle stops temporarily when it is lowering or becomes steady above normal position.         | Back pressure too high, or exhaust system clogged                             |
| 3. Needle intermittently drops to position lower than normal position.  | Leakage around cylinder   |
| 4. Needle drops suddenly and intermittently from normal position.   | Sticky valves   |
| 5. When engine speed is gradually increased, needle begins to vibrate rapidly at certain speed, and then vibration increases as engine speed increases. | Weak or broken valve springs  |
| 6. Needle vibrates above and below normal position in narrow range.   | Defective ignition system or throttle chamber idle adjustment                 |

## 6. Engine Oil Pressure

### A: INSPECTION

- 1) Remove oil pressure switch from engine cylinder block. <Ref. to LU-21, REMOVAL, Oil Pressure Switch.>
- 2) Connect oil pressure gauge hose to cylinder block.
- 3) Connect battery ground cable.

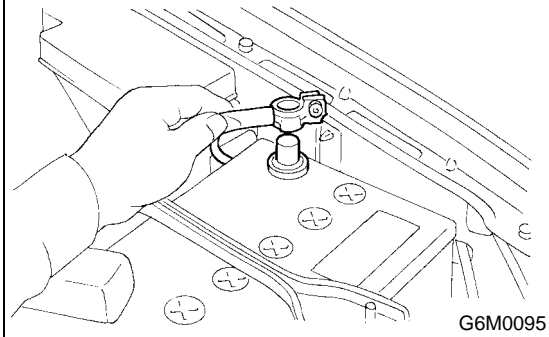

- 4) Start the engine, and measure oil pressure.

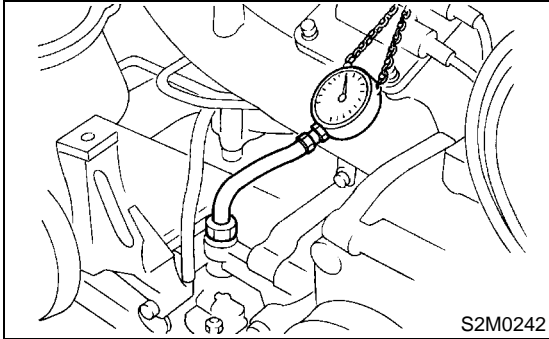

#### **Oil pressure:**

**98 kPa (1.0 kg/cm<sup>2</sup>, 14 psi) or more at 800 rpm**  
**294 kPa (3.0 kg/cm<sup>2</sup>, 43 psi) or more at 5,000 rpm**

#### **CAUTION:**

- If oil pressure is out of specification, check oil pump, oil filter and lubrication line. <Ref. to LU-26, INSPECTION, Engine Lubrication System Trouble in General.>
- If oil pressure warning light is turned ON and oil pressure is in specification, replace oil pressure switch. <Ref. to LU-26, INSPECTION, Engine Lubrication System Trouble in General.>

#### **NOTE:**

The specified data is based on an engine oil temperature of 80°C (176°F).

- 5) After measuring oil pressure, install oil pressure switch. <Ref. to LU-22, INSTALLATION, Oil Pressure Switch.>

#### **Tightening torque:**

**25 N·m (2.5 kgf-m, 18.1 ft-lb)**

## 7. Fuel Pressure

### A: INSPECTION

**WARNING:**

Before removing fuel pressure gauge, release fuel pressure.

**NOTE:**

If out of specification, check or replace pressure regulator and pressure regulator vacuum hose.

1) Release fuel pressure. <Ref. to FU(DOHC TURBO)-49, RELEASING OF FUEL PRESSURE, OPERATION, Fuel.>

2) Open fuel flap lid, and remove fuel filler cap.

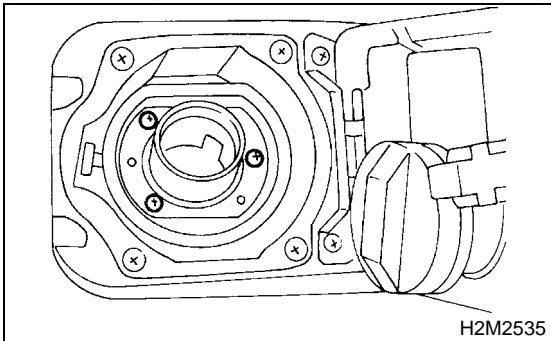

3) Disconnect fuel delivery hoses from fuel filter, and connect fuel pressure gauge.

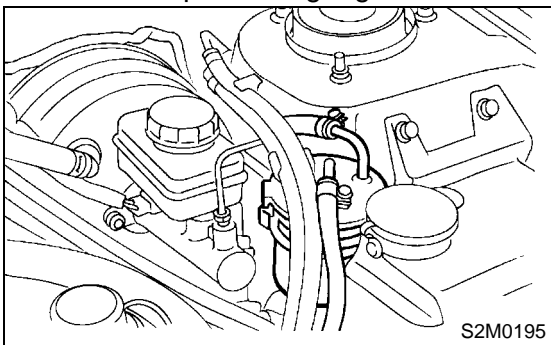

4) Connect connector of fuel pump relay.

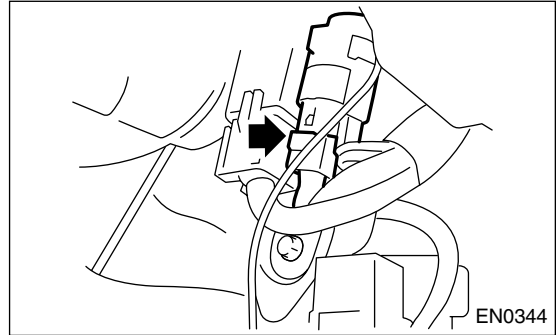

5) Start the engine.

6) Measure fuel pressure while disconnecting pressure regulator vacuum hose from intake manifold.

**Fuel pressure:**

**Standard; 284 — 314 kPa (2.9 — 3.2 kgf/cm<sup>2</sup>, 41 — 46 psi)**

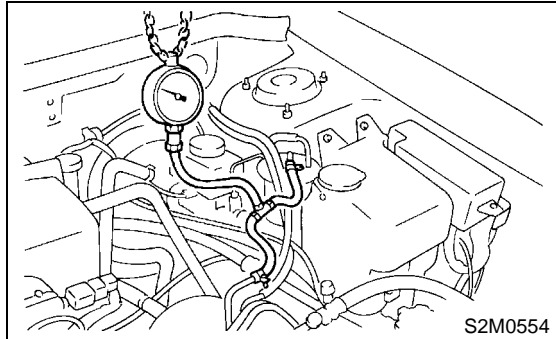

7) After connecting pressure regulator vacuum hose, measure fuel pressure.

**Fuel pressure:**

**Standard; 230 — 260 kPa (2.35 — 2.65 kgf/cm<sup>2</sup>, 33 — 38 psi)**

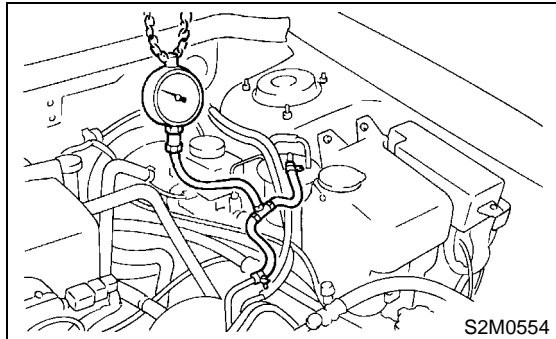

**NOTE:**

The fuel pressure gauge registers 10 to 20 kPa (0.1 to 0.2 kgf/cm<sup>2</sup>, 1 to 3 psi) higher than standard values during high-altitude operations.

# VALVE CLEARANCE

MECHANICAL

## 8. Valve Clearance

### A: INSPECTION

#### CAUTION:

Inspection and adjustment of valve clearance should be performed while engine is cold.

- 1) Set the vehicle onto the lift.
- 2) Disconnect battery ground cable.

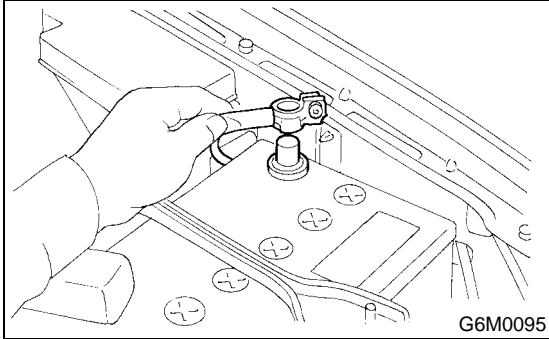

- 3) Remove air intake duct. <Ref. to IN(DOHC TURBO)-8, REMOVAL, Air Intake Duct.>
- 4) Remove one bolt which secures timing belt cover (RH).
- 5) Lift-up the vehicle.
- 6) Remove under cover.
- 7) Loosen remaining bolts which secure timing belt cover (RH), then remove belt cover.
- 8) Lower the vehicle.
- 9) When inspecting #1 and #3 cylinders:

- (1) Pull out engine harness connector with bracket from air cleaner upper cover.

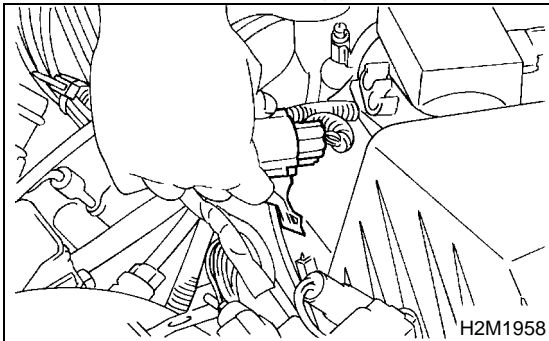

- (2) Remove air cleaner case. <Ref. to IN(DOHC TURBO)-7, REMOVAL, Air Cleaner.>
- (3) Disconnect spark plug cords from spark plugs (#1 and #3 cylinders).
- (4) Place suitable container under the vehicle.
- (5) Disconnect PCV hose from rocker cover (RH).
- (6) Remove bolts, then remove rocker cover (RH).

- 10) When inspecting #2 and #4 cylinders;
  - (1) Disconnect battery cables, and then remove battery and battery carrier.

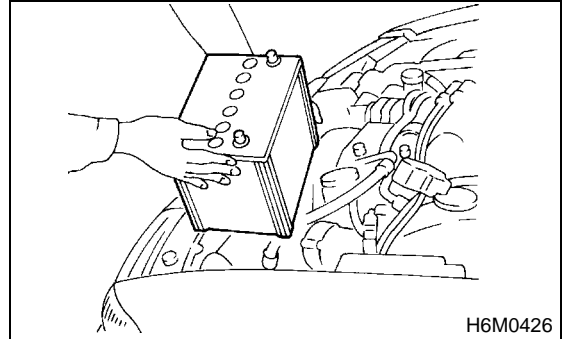

- (2) Remove bolt which secures engine harness bracket onto body.

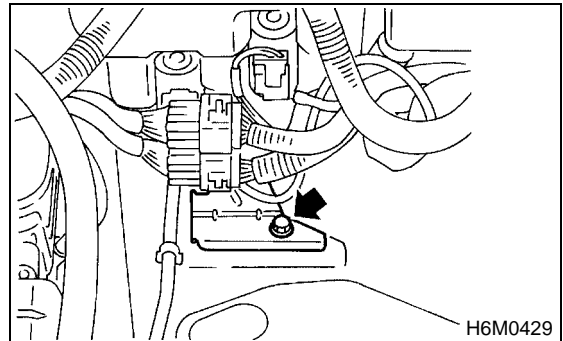

- (3) Disconnect washer motor connectors.

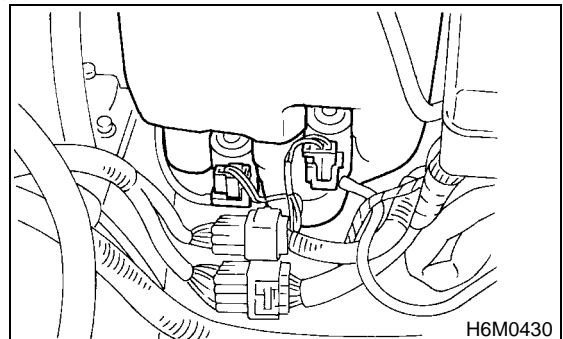

- (4) Remove washer tank mounting bolts.

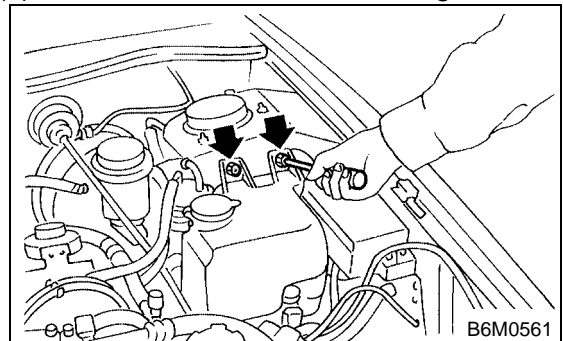

# VALVE CLEARANCE

MECHANICAL

(5) Move washer tank upward.

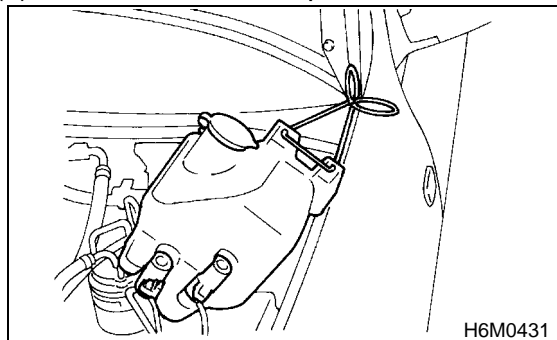

(6) Disconnect spark plug cords from spark plugs (#2 and #4 cylinders).

(7) Place suitable container under the vehicle.

(8) Disconnect PCV hose from rocker cover (LH).

(9) Remove bolts, then remove rocker cover (LH).

11) Turn crankshaft pulley clockwise until arrow mark on camshaft sprocket is set to position shown in figure.

**NOTE:**

Turn crankshaft using ST.

ST 499987500 CRANKSHAFT SOCKET

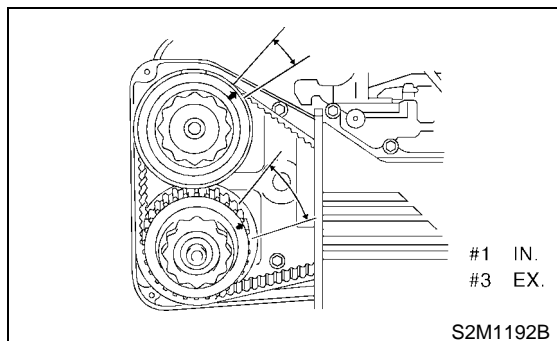

12) Measure #1 cylinder intake valve and #3 cylinder exhaust valve clearance by using thickness gauge (A).

**CAUTION:**

- Insert the thickness gauge in as horizontal a direction as possible with respect to the shim.
- Measure exhaust valve clearances while lifting-up the vehicle.

**Valve clearance:**

**Intake:**  $0.20 \pm 0.02$  mm ( $0.0079 \pm 0.0008$  in)

**Exhaust:**  $0.25 \pm 0.02$  mm ( $0.0098 \pm 0.0008$  in)

**NOTE:**

If the measured value is not within specification, take notes of the value in order to adjust the valve clearance later on.

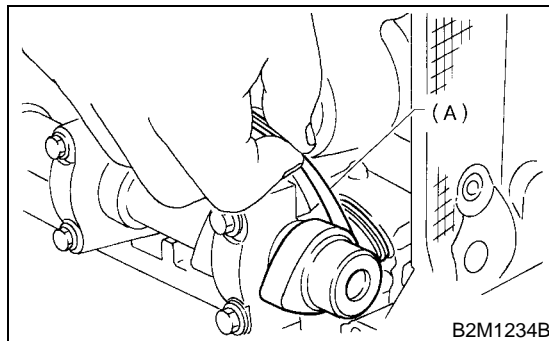

13) If necessary, adjust the valve clearance. <Ref. to ME(DOHC TURBO)-30, ADJUSTMENT, Valve Clearance.>

14) Further turn crankshaft pulley clockwise.

Using the same procedures described previously, then measure valve clearances again.

(1) Set arrow mark on camshaft sprocket to position shown in figure, and measure #2 cylinder exhaust valve and #3 cylinder intake valve clearances.

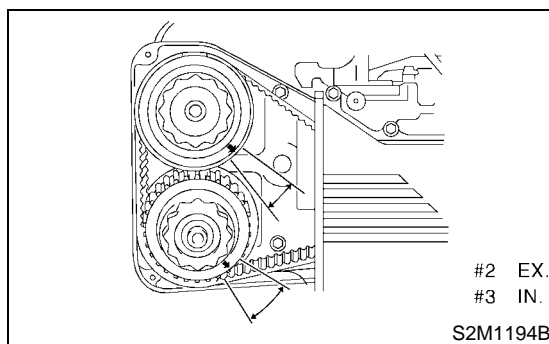

(2) Set arrow mark on camshaft sprocket to position shown in figure, and measure #2 cylinder intake valve and #4 cylinder exhaust valve clearances.

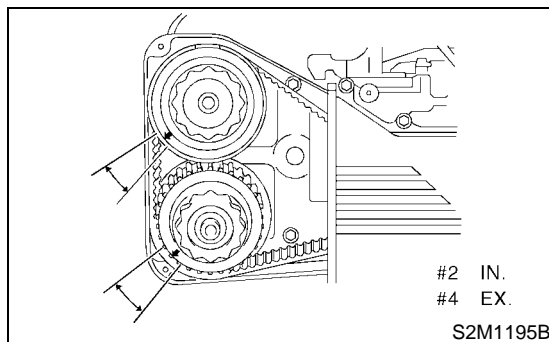

# VALVE CLEARANCE

## MECHANICAL

(3) Set arrow mark on camshaft sprocket to position shown in figure, and measure #1 cylinder exhaust valve and #4 cylinder intake valve clearances.

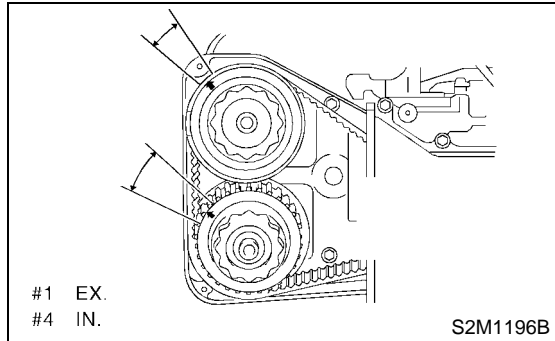

15) After inspection, install the related parts in the reverse order of removal.

### Tightening torque:

**32 N·m (3.3 kgf-m, 24 ft-lb)**

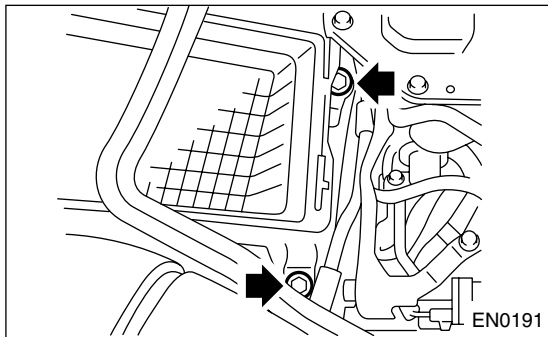

## B: ADJUSTMENT

### CAUTION:

Adjustment of valve clearance should be performed while engine is cold.

1) Measure all valve clearances. <Ref. to ME(DOHC TURBO)-28, INSPECTION, Valve Clearance.>

### NOTE:

Record each valve clearance after it has been measured.

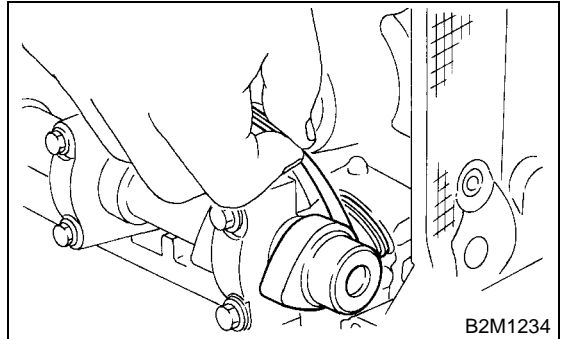

2) Remove shim from valve lifter.

(1) Prepare the ST.

ST 498187200 SHIM REPLACER

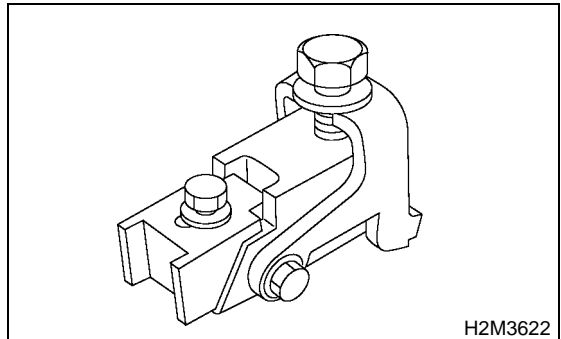

(2) Rotate the notch of the valve lifter outward by 45°.

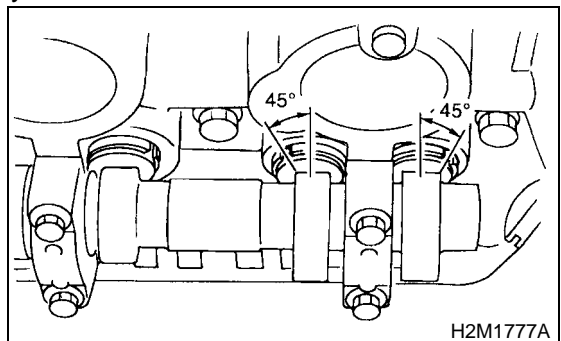

# VALVE CLEARANCE

MECHANICAL

- (3) Adjust SHIM REPLACER notch to valve lifter and set it.

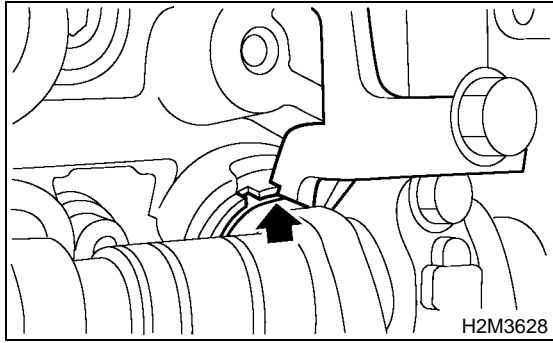

**NOTE:**

When setting, be careful SHIM REPLACER edge does not touch shim.

- (4) Tighten bolt (A) and install it to the cylinder head.  
 (5) Tighten bolt (B) and insert the valve lifter.

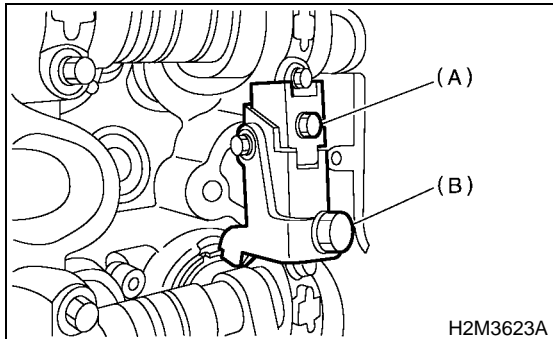

- (6) Insert tweezers into the notch of the valve lifter, and take the shim out.

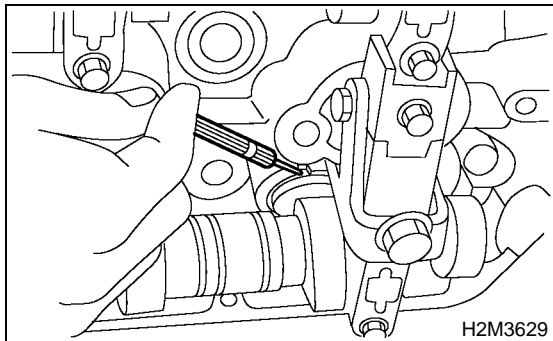

**NOTE:**

By using a magnet (A), the shim (B) can be taken out without dropping it.

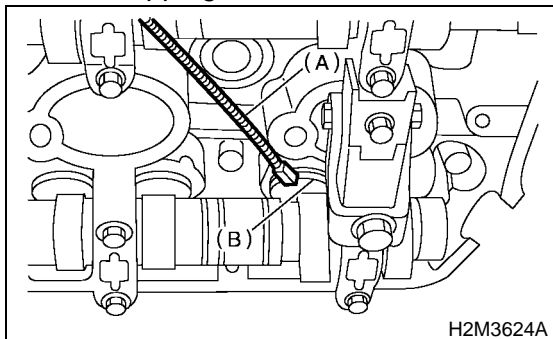

- 3) Measure thickness of shim with micrometer.

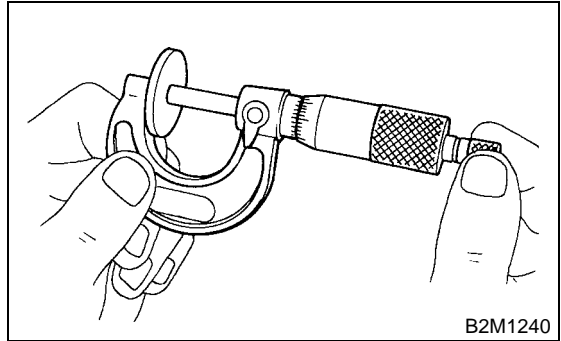

- 4) Select a shim of suitable thickness using measured valve clearance and shim thickness, by referring to the following table.  
 5) Set suitable shim selected in step 4) to valve lifter.

| Unit: mm       |                           |
|----------------|---------------------------|
| Intake valve:  | $S = (V + T) - 0.20$      |
| Exhaust valve: | $S = (V + T) - 0.25$      |
| S:             | Shim thickness to be used |
| V:             | Measured valve clearance  |
| T:             | Shim thickness required   |



# VALVE CLEARANCE

## MECHANICAL

---

| Part No.    | Thickness mm (in) |
|-------------|-------------------|
| 13218 AK010 | 2.00 (0.0787)     |
| 13218 AK020 | 2.02 (0.0795)     |
| 13218 AK030 | 2.04 (0.0803)     |
| 13218 AK040 | 2.06 (0.0811)     |
| 13218 AK050 | 2.08 (0.0819)     |
| 13218 AK060 | 2.10 (0.0827)     |
| 13218 AK070 | 2.12 (0.0835)     |
| 13218 AK080 | 2.14 (0.0843)     |
| 13218 AK090 | 2.16 (0.0850)     |
| 13218 AK100 | 2.18 (0.0858)     |
| 13218 AK110 | 2.20 (0.0866)     |
| 13218 AE710 | 2.22 (0.0874)     |
| 13218 AE730 | 2.24 (0.0882)     |
| 13218 AE750 | 2.26 (0.0890)     |
| 13218 AE770 | 2.28 (0.0898)     |
| 13218 AE790 | 2.30 (0.0906)     |
| 13218 AE810 | 2.32 (0.0913)     |
| 13218 AE830 | 2.34 (0.0921)     |
| 13218 AE850 | 2.36 (0.0929)     |
| 13218 AE870 | 2.38 (0.0937)     |
| 13218 AE890 | 2.40 (0.0945)     |
| 13218 AE910 | 2.42 (0.0953)     |
| 13218 AE920 | 2.43 (0.0957)     |
| 13218 AE930 | 2.44 (0.0961)     |
| 13218 AE940 | 2.45 (0.0965)     |
| 13218 AE950 | 2.46 (0.0969)     |
| 13218 AE960 | 2.47 (0.0972)     |
| 13218 AE970 | 2.48 (0.0976)     |
| 13218 AE980 | 2.49 (0.0980)     |
| 13218 AE990 | 2.50 (0.0984)     |
| 13218 AF000 | 2.51 (0.0988)     |
| 13218 AF010 | 2.52 (0.0992)     |
| 13218 AF020 | 2.53 (0.0996)     |
| 13218 AF030 | 2.54 (0.1000)     |
| 13218 AF040 | 2.55 (0.1004)     |
| 13218 AF050 | 2.56 (0.1008)     |
| 13218 AF060 | 2.57 (0.1012)     |
| 13218 AF070 | 2.58 (0.1016)     |
| 13218 AF090 | 2.60 (0.1024)     |
| 13218 AF110 | 2.62 (0.1031)     |
| 13218 AF130 | 2.64 (0.1039)     |
| 13218 AF150 | 2.66 (0.1047)     |
| 13218 AF170 | 2.68 (0.1055)     |
| 13218 AF190 | 2.70 (0.1063)     |

6) Inspect all valves for clearance again at this stage. If the valve clearance is not correct, repeat the procedure over again from the first step.

7) After inspection, install the related parts in the reverse order of removal.

## 9. Engine Assembly

### A: REMOVAL

- 1) Set the vehicle on lift arms.
- 2) Open front hood fully and support with stay.
- 3) Raise rear seat, and turn floor mat up.
- 4) Release fuel pressure.
  - (1) Disconnect fuel pump relay connector.



- (2) Start the engine, and run until stalls.
- (3) After the engine stalls, crank it for five seconds more.
- (4) Turn ignition switch to "OFF".
- 5) Remove filler cap.
- 6) Disconnect battery ground terminal.

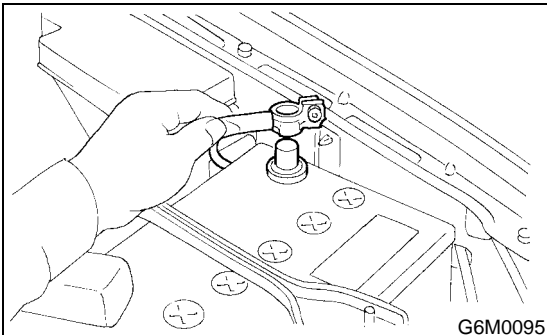

- 7) Remove radiator from vehicle. <Ref. to CO-37, REMOVAL, Radiator.>
- 8) Remove coolant filler tank. <Ref. to CO-51, REMOVAL, Coolant Filler Tank.>
- 9) Collect refrigerant, and remove pressure hoses.
  - (1) Place and connect the attachment hose to the refrigerant recycle system.
  - (2) Collect refrigerant from A/C system.
  - (3) Disconnect A/C pressure hoses from A/C compressor.

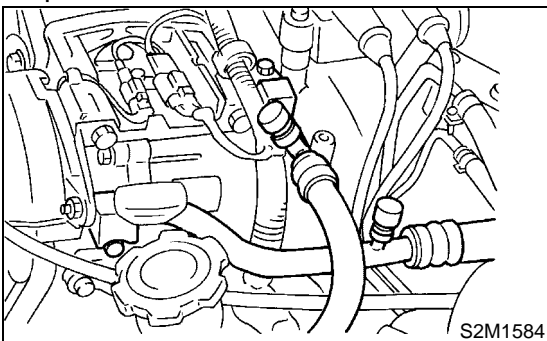

- 10) Remove intercooler. <Ref. to IN(DOHC TURBO)-10, REMOVAL, Intercooler.>

- 11) Disconnect the following connectors and cable.

- (1) Engine harness connector

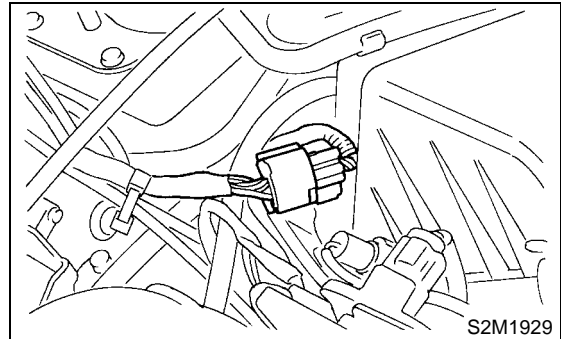

- (2) Engine ground terminal

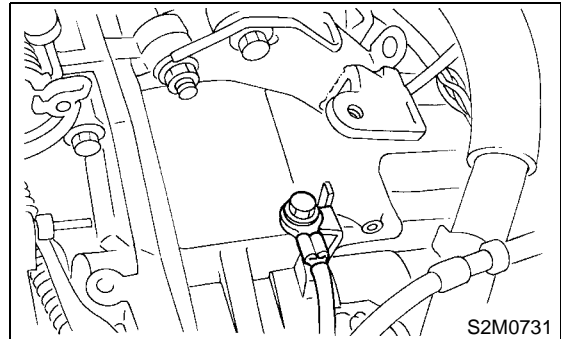

- (3) Engine harness connector

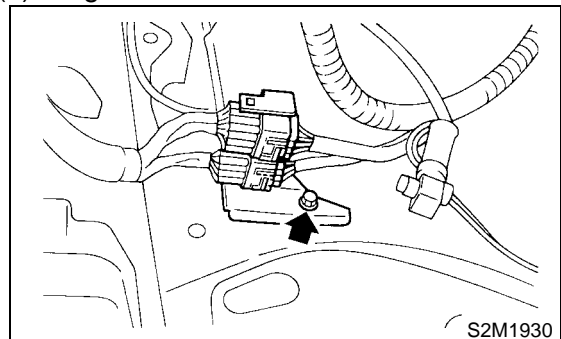

# ENGINE ASSEMBLY

## MECHANICAL

- (4) Generator connector, terminal and A/C compressor connectors

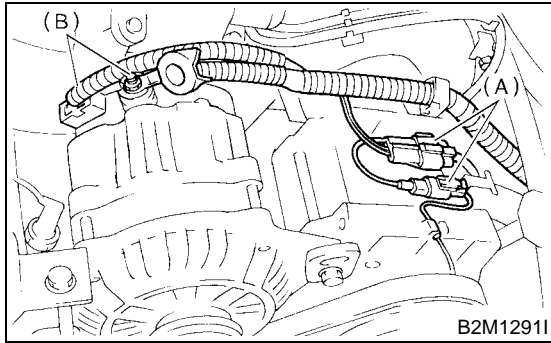

- (A) A/C compressor connector  
(B) Generator connector and terminal

- (5) Accelerator cable

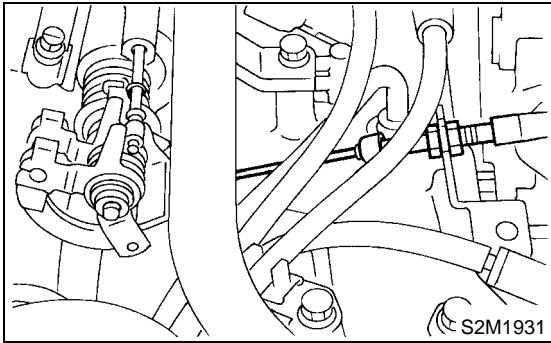

- (6) Clutch release spring

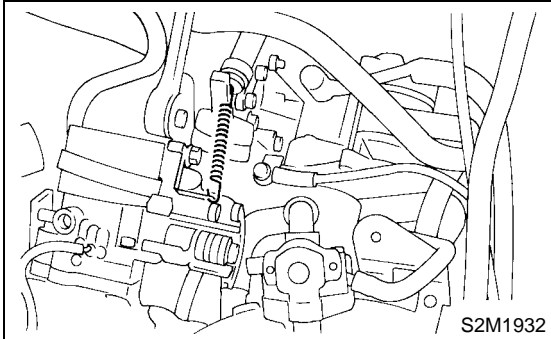

- 12) Disconnect the following hoses

- (1) Brake booster vacuum hose

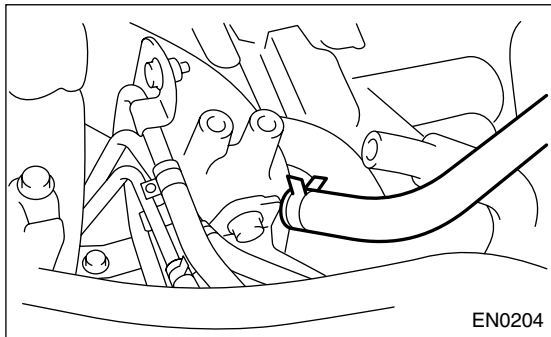

- (2) Heater inlet outlet hose

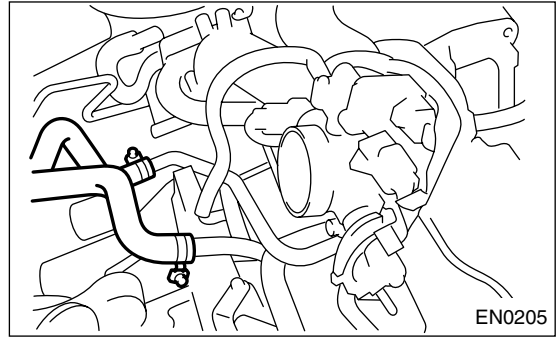

- 13) Remove power steering pump from bracket.  
(1) Loosen lock bolt and slider bolt, and remove front side V-belt. <Ref. to ME(DOHC TURBO)-43, FRONT SIDE BELT, REMOVAL, V-belt.>  
(2) Disconnect the power steering switch connector.

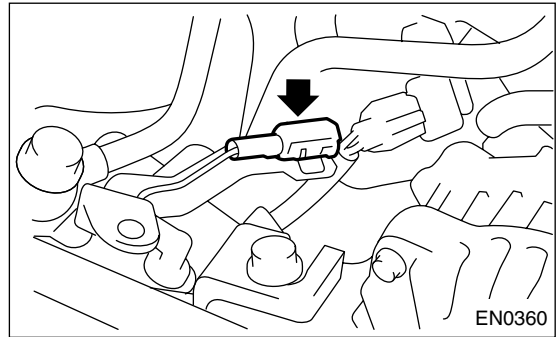

- (3) Remove pipe with bracket from intake manifold.

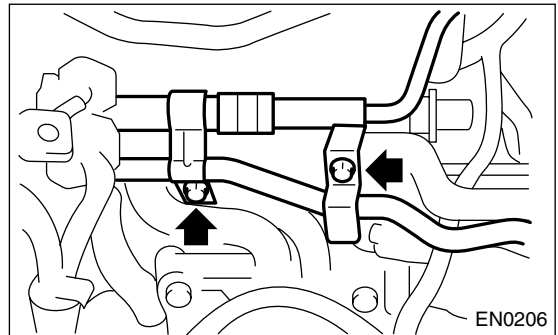

- (4) Remove power steering pump from engine.

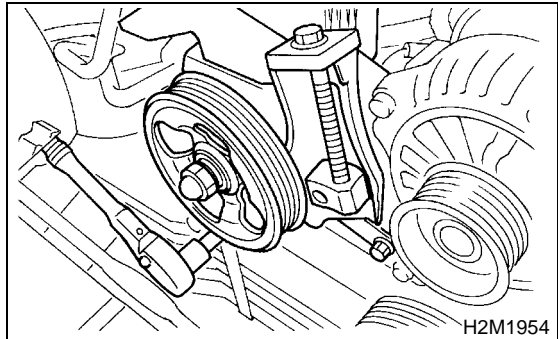

(5) Remove power steering tank from the bracket by pulling it upward.

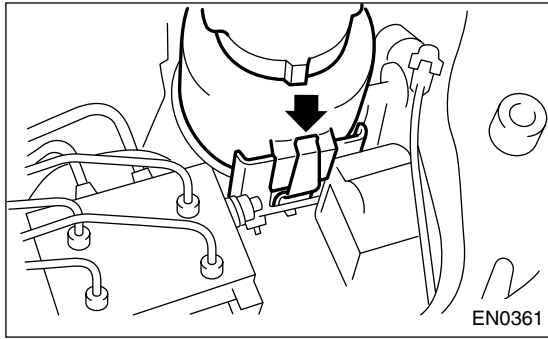

(6) Place power steering pump on the right side wheel apron.

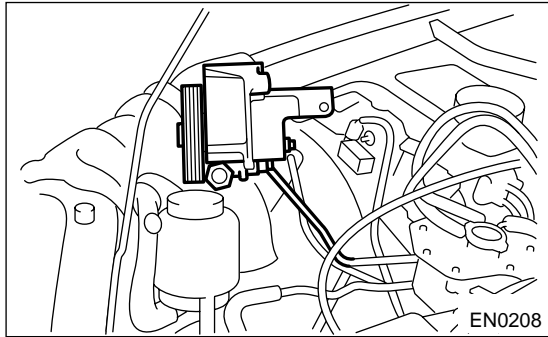

14) Remove center exhaust pipe. <Ref. to EX(DOHC TURBO)-8, REMOVAL, Center Exhaust Pipe.>

15) Remove nuts which hold lower side of transmission to engine.

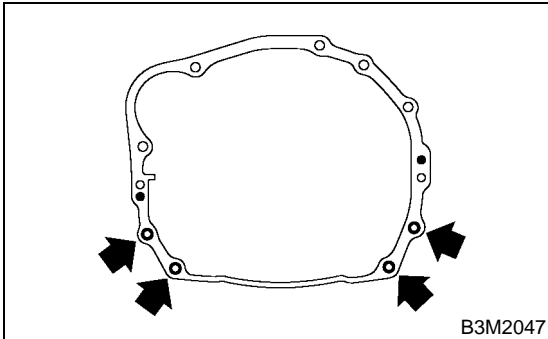

16) Remove nuts which install front cushion rubber onto front crossmember.

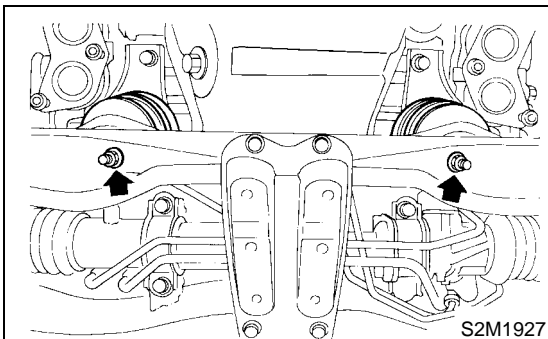

17) Separate clutch release fork from release bearing.

(1) Remove clutch operating cylinder from transmission.

(2) Remove plug using 10 mm hexagon wrench.

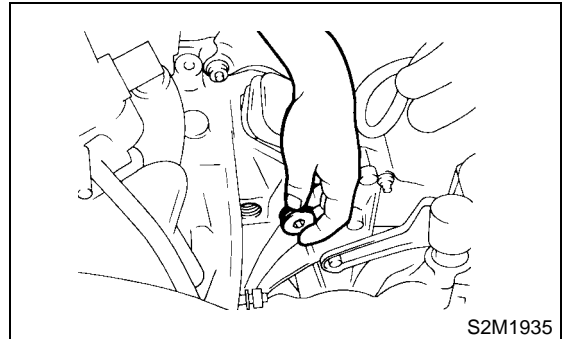

(3) Screw 6 mm dia. bolt into release fork shaft, and remove it.

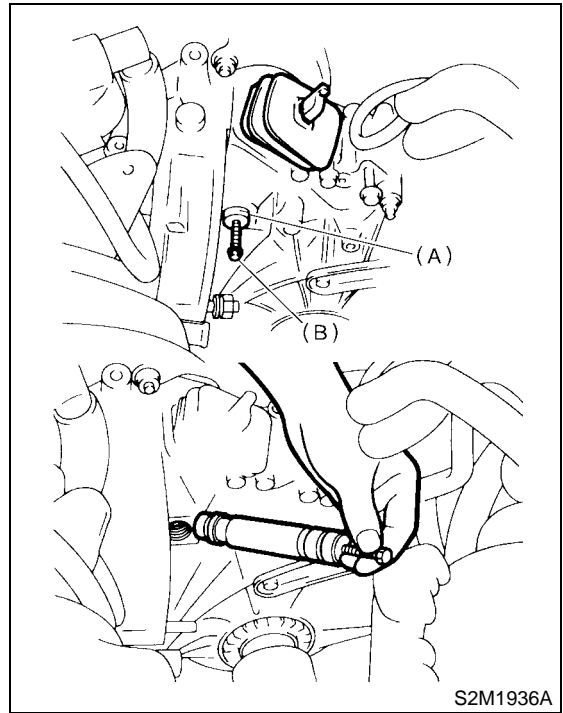

(A) Shaft

(B) Bolt

(4) Raise release fork and unfasten release bearing tabs to free release fork.

**CAUTION:**

**Step (4) is required to prevent interference with engine when removing engine from transmission.**

# ENGINE ASSEMBLY

## MECHANICAL

18) Remove pitching stopper.

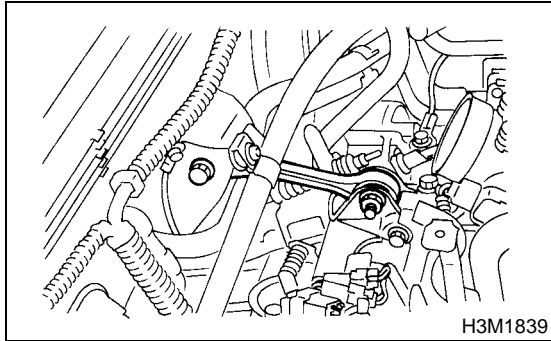

19) Disconnect fuel delivery hose, return hose and evaporation hose.

**CAUTION:**

- Catch fuel from hose into container.
- Disconnect hose with its end wrapped with cloth to prevent fuel from splashing.

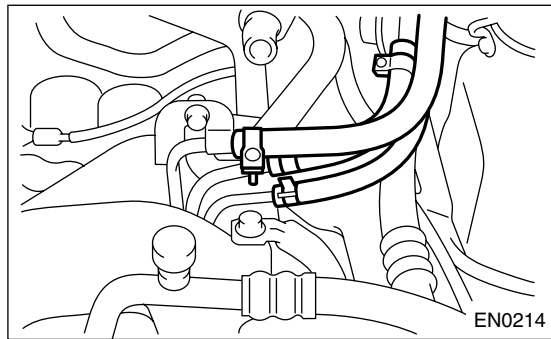

20) Remove fuel filter and bracket.

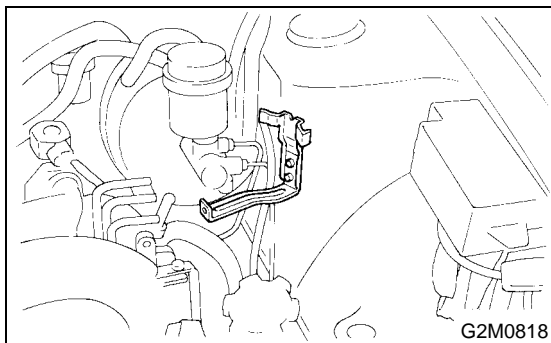

21) Support engine with a lifting device and wire ropes.

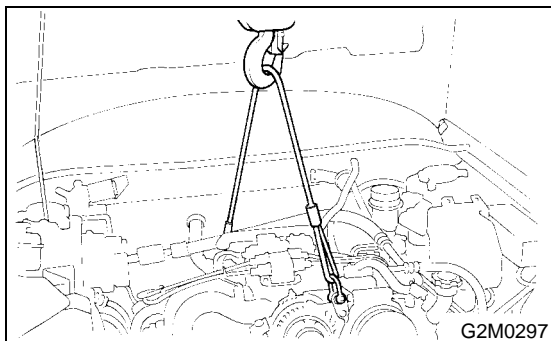

22) Support transmission with a garage jack.

**CAUTION:**

Before moving engine away from transmission, check to be sure no work has been overlooked. Doing this is very important in order to facilitate re-installation and because transmission lowers under its own weight.

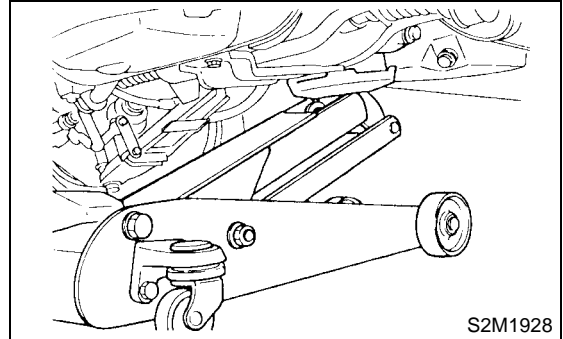

23) Separation of engine and transmission.

- (1) Remove starter. <Ref. to SC-5, REMOVAL, Starter.>
- (2) Remove bolt which holds right upper side of transmission to engine.

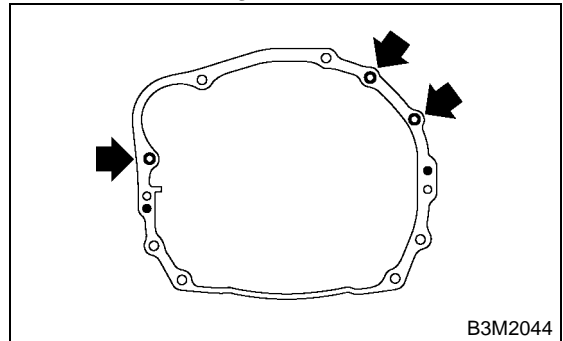

24) Remove engine from vehicle.

- (1) Slightly raise engine.
- (2) Raise transmission with garage jack.
- (3) Move engine horizontally until mainshaft is withdrawn from clutch cover.
- (4) Slowly move engine away from engine compartment.

**CAUTION:**

Be careful not to damage adjacent parts or body panels with crank pulley, oil pressure gauge, etc.

25) Remove front cushion rubbers.

## B: INSTALLATION

1) Install clutch release fork and bearing onto transmission.

(1) Remove release bearing from clutch cover with flat type screw driver.

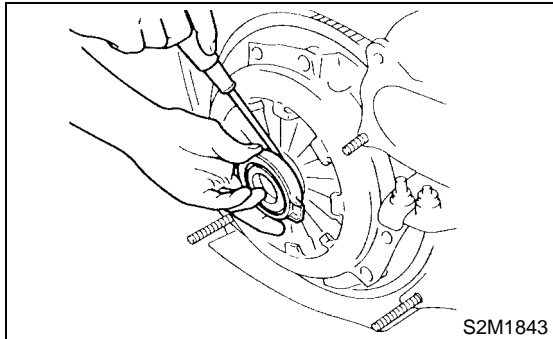

(2) Install release bearing on transmission.

(3) Install release fork into release bearing tab.

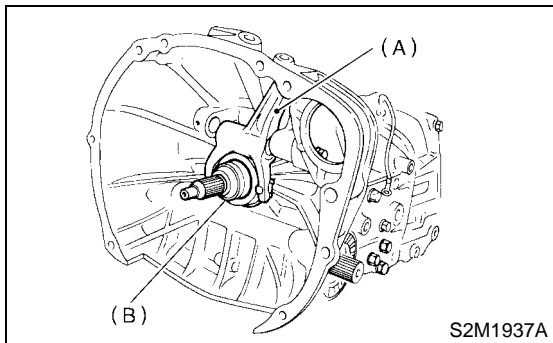

- (A) Release fork
- (B) Release bearing

- (4) Apply grease to specified points.
  - Spline FX2200
  - Shaft SUNLIGHT 2

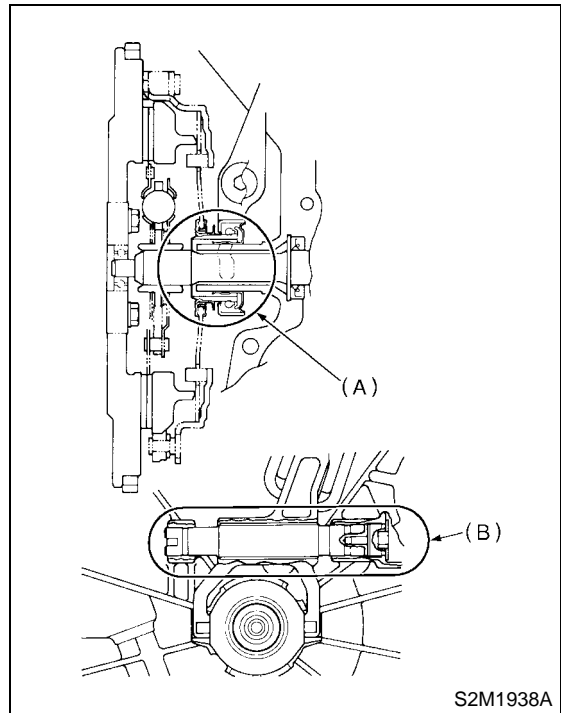

- (A) Spline (FX2200)
- (B) Shaft (SUNLIGHT 2)

(5) Insert release fork shaft into release fork.

### CAUTION:

**Make sure the cutout portion of release fork shaft contacts spring pin.**

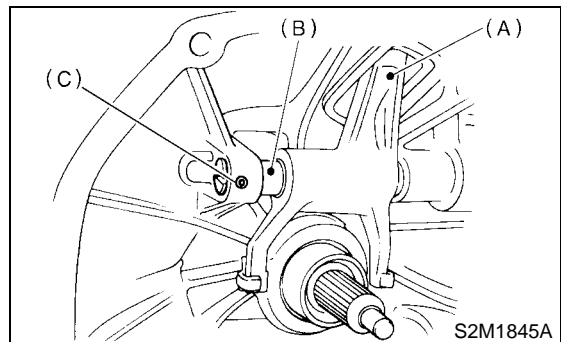

- (A) Release fork
- (B) Release shaft
- (C) Spring pin

# ENGINE ASSEMBLY

## MECHANICAL

(6) Tighten plug.

**Tightening torque:**

**44 N·m (4.5 kgf-m, 32.5 ft-lb)**

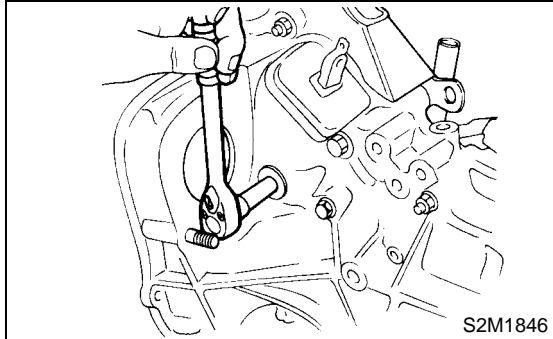

2) Install front cushion rubbers to engine.

**Tightening torque:**

**34 N·m (3.5 kgf-m, 25.3 ft-lb)**

3) Install engine onto transmission.

(1) Position engine in engine compartment and align it with transmission.

### CAUTION:

Be careful not to damage adjacent parts or body panels with crank pulley, oil pressure gauge, etc.

(2) Apply a small amount of grease to splines of mainshaft.

4) Tighten bolt which hold right upper side of transmission to engine.

**Tightening torque:**

**50 N·m (5.1 kgf-m, 36.9 ft-lb)**

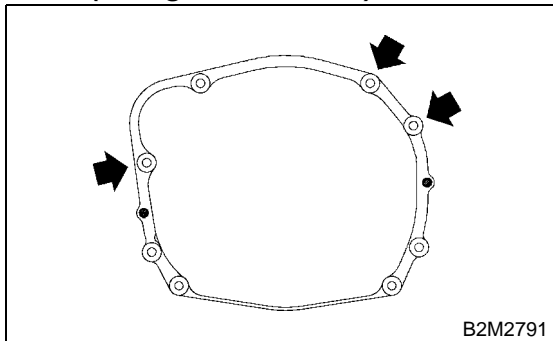

5) Remove lifting device and wire ropes.

6) Remove garage jack.

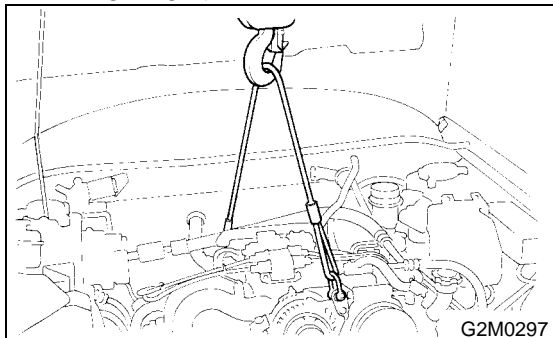

7) Install pitching stopper.

**Tightening torque:**

**T1: 49 N·m (5.0 kgf-m, 36.2 ft-lb)**

**T2: 57 N·m (5.8 kgf-m, 42 ft-lb)**

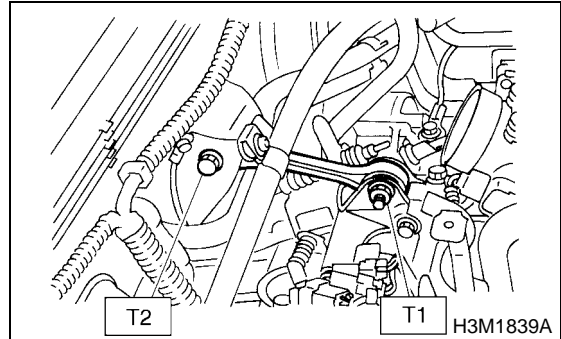

8) Install starter. <Ref. to SC-6, INSTALLATION, Starter.>

9) Install fuel filter and bracket.

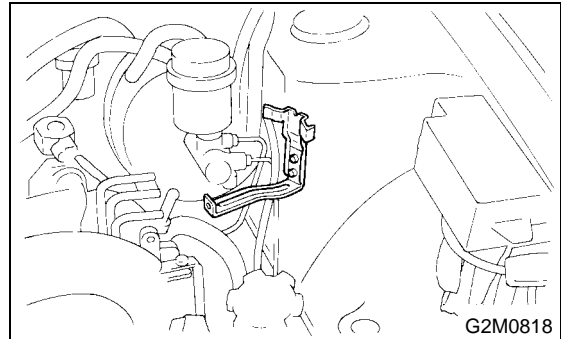

10) Install power steering pump on bracket.

(1) Install the power steering tank on bracket.

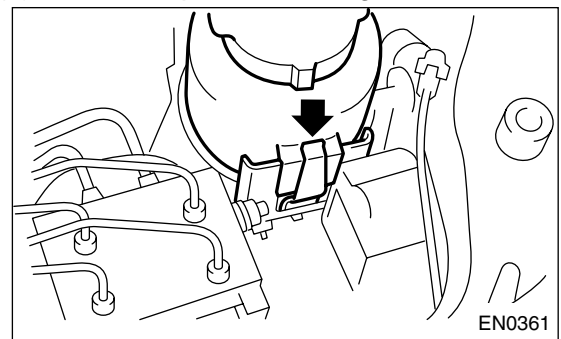

(2) Install power steering pump on bracket, and tighten bolts.

**Tightening torque:**

**20.1 N·m (2.05 kgf-m, 14.8 ft-lb)**

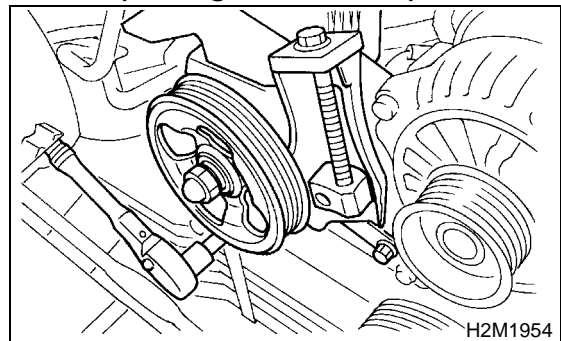

(3) Install power steering pipe bracket on right side intake manifold, and install spark plug codes.

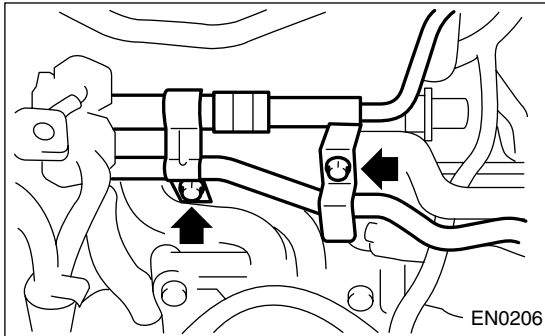

(4) Connect power steering switch connector.

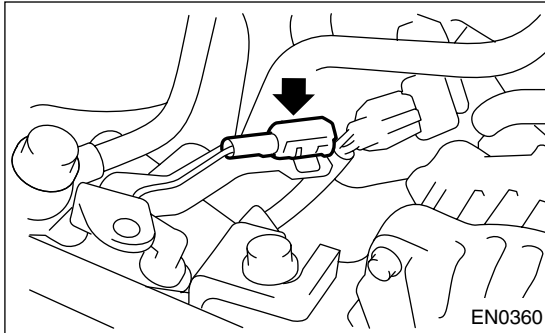

(5) Install front side V-belt, and adjust it. <Ref. to ME(SOHC)-42, FRONT SIDE BELT, INSTALLATION, V-belt.>

11) Tighten nuts which hold lower side of transmission to engine.

**Tightening torque:**

**50 N·m (5.1 kgf·m, 36.9 ft·lb)**

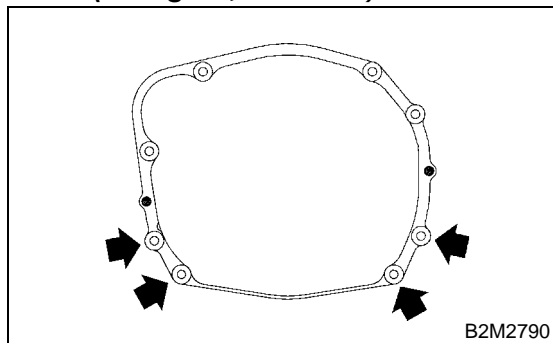

12) Tighten nuts which install front cushion rubber onto crossmember.

**Tightening torque:**

**83 N·m (8.5 kgf·m, 61 ft·lb)**

**CAUTION:**

**Make sure the front cushion rubber mounting bolts (A) and locator (B) are securely installed.**

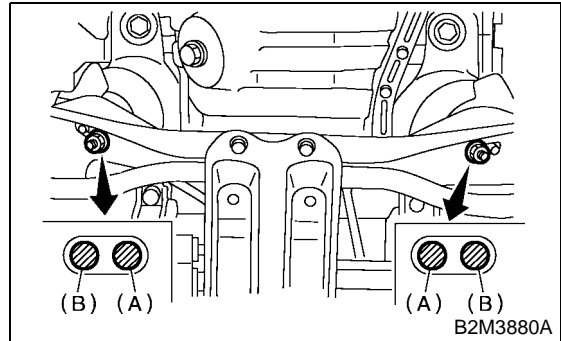

13) Install center exhaust pipe.

<Ref. to EX(DOHC TURBO)-9, INSTALLATION, Center Exhaust Pipe.>

14) Connect the following hoses.

- (1) Fuel delivery hose, return hose and evaporation hose
- (2) Heater inlet and outlet hoses
- (3) Brake booster vacuum hose

15) Connect the following connectors and terminals.

- (1) Engine ground terminal
- (2) Engine harness connectors
- (3) Generator connector and terminal
- (4) A/C compressor connectors (With A/C)

16) Connect the following cables.

- (1) Accelerator cable
- (2) Clutch release spring

**CAUTION:**

**After connecting each cable, adjust them.**

17) Install air intake system.

- (1) Install intercooler. <Ref. to IN(DOHC TURBO)-11, INSTALLATION, Intercooler.>
- (2) Install air cleaner element and air cleaner upper cover.
- (3) Install engine harness connector bracket.
- (4) Install filler hose to air cleaner case.

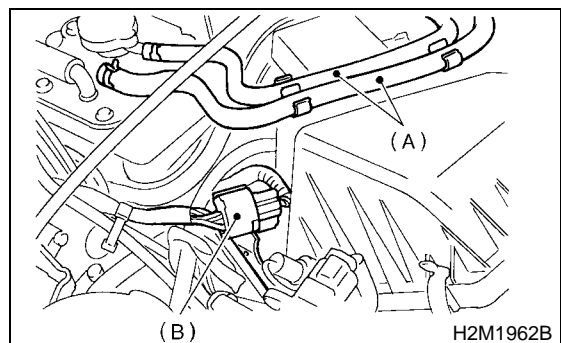

- (A) Filler hose
- (B) Connector bracket



# ENGINE ASSEMBLY

## MECHANICAL

---

18) Install A/C pressure hoses. (With A/C)

**CAUTION:**

**Use new O-rings.**

**Tightening torque:**

**25 N·m (2.5 kgf·m, 18.1 ft·lb)**

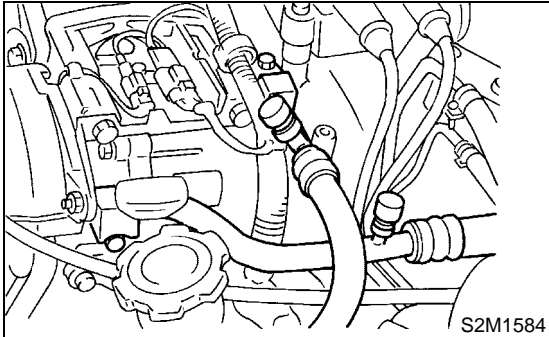

19) Install radiator. <Ref. to CO-40, INSTALLATION, Radiator.>

20) Install coolant filler tank. <Ref. to CO-51, INSTALLATION, Coolant Filler Tank.>

21) Install window washer tank.

22) Install battery in the vehicle, and connect cables.

23) Fill coolant.

<Ref. to CO-25, FILLING OF ENGINE COOLANT, REPLACEMENT, Engine Coolant.>

24) Charge A/C system with refrigerant.

<Ref. to AC-17, OPERATION, Refrigerant Charging Procedure.>

25) Remove front hood stay, and close front hood.

26) Take off the vehicle from lift arms.

## 10.Engine Mounting

### A: REMOVAL

- 1) Remove engine assembly. <Ref. to ME(DOHC TURBO)-33, REMOVAL, Engine Assembly.>
- 2) Remove engine mounting from engine assembly.

### B: INSTALLATION

Install in the reverse order of removal.

#### *Tightening torque:*

#### *Engine mounting;*

*35 N·m (3.6 kgf-m, 25.8 ft-lb)*

### C: INSPECTION

Make sure there are no cracks or other damage.

## 11.Preparation for Overhaul

### A: PROCEDURE

1) After removing the engine from the body, secure it in the ST shown below.

|     |           |                            |
|-----|-----------|----------------------------|
| ST1 | 498457000 | ENGINE STAND ADAPTER<br>RH |
| ST2 | 498457100 | ENGINE STAND ADAPTER<br>LH |
| ST3 | 499817000 | ENGINE STAND               |

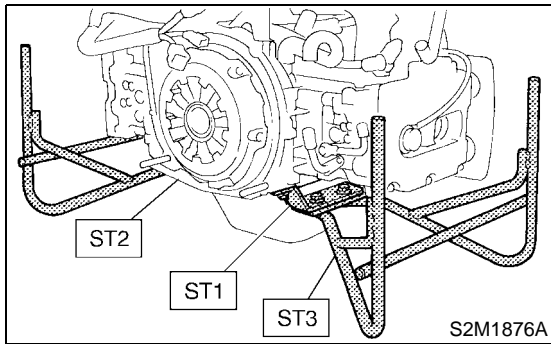

2) In this section the procedures described under each index are all connected and stated in order. It will be the complete procedure for overhauling of the engine itself when you go through all steps in the process.

Therefore, in this section, to conduct the particular procedure within the flow of a section, you need to go back and conduct the procedure described previously in order to do that particular procedure.

## 12.V-belt

### A: REMOVAL

#### 1. FRONT SIDE BELT

**NOTE:**

Perform the following procedures 1) to 4) with the engine installed to the body.

- 1) Remove V-belt cover.

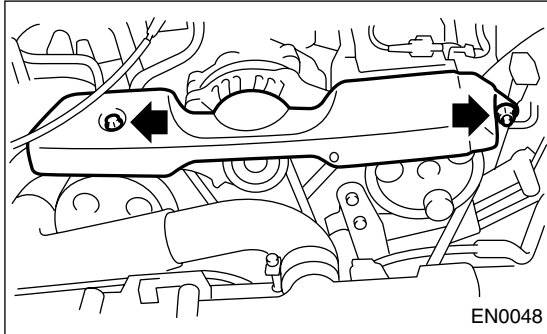

- 2) Loosen the lock bolt (A).
- 3) Loosen the slider bolt (B).
- 4) Remove the front side belt (C).

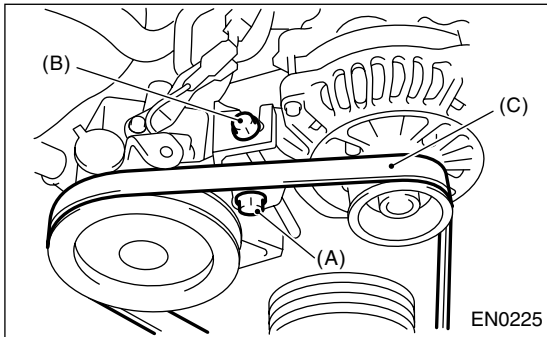

#### 2. REAR SIDE BELT

- 1) Loosen the lock nut (A).
- 2) Loosen the slider bolt (B).

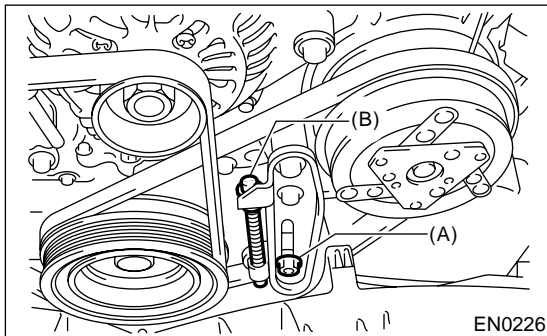

- 3) Remove the A/C belt.
- 4) Remove the A/C belt tensioner.

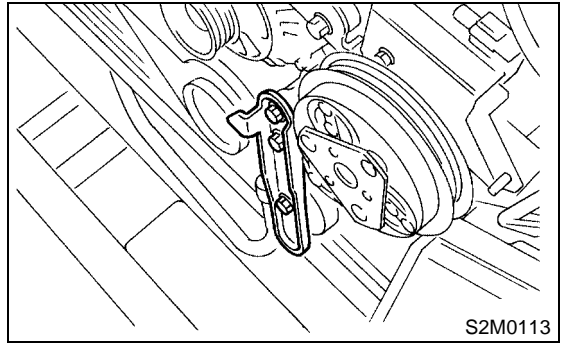

### B: INSTALLATION

#### 1. FRONT SIDE BELT

**CAUTION:**

**Wipe off any oil or water on the belt and pulley.**

- 1) Install a belt, and tighten the slider bolt so as to obtain the specified belt tension <Ref. to ME(DOHC TURBO)-44, INSPECTION, V-belt.>
- 2) Tighten the lock bolt (A)
- 3) Tighten slider bolt (B).

**Tightening torque:**

**Lock bolt through bolt:**

**25 N·m (2.5 kgf·m, 18 ft·lb)**

**Slider bolt:**

**8 N·m (0.8 kgf·m, 5.5 ft·lb)**

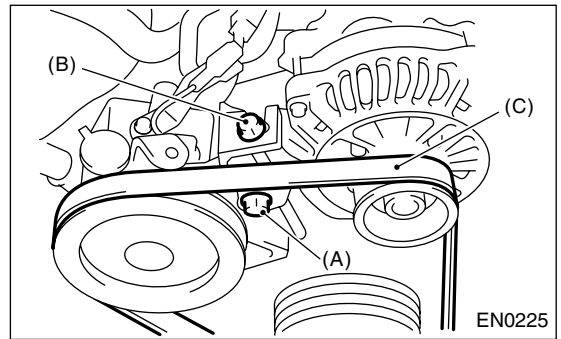

# V-BELT

## MECHANICAL

### 2. REAR SIDE BELT

- 1) Install a belt, and tighten the slider bolt (B) so as to obtain the specified belt tension. <Ref. to ME(DOHC TURBO)-44, INSPECTION, V-belt.>
- 2) Tighten the lock nut (A).

#### Tightening torque:

Lock nut (A);

**22.6 N·m (2.3 kgf-m, 16.6 ft-lb)**

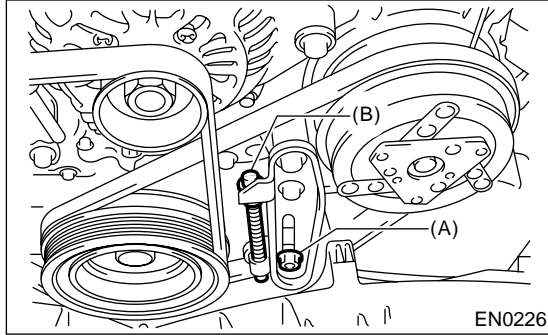

### C: INSPECTION

- 1) Replace belts, if cracks, fraying or wear is found.
- 2) Check drive belt tension and adjust it if necessary by changing generator installing position and/or idler pulley installing position.

#### Belt tension

(A)

replaced: 7 — 9 mm (0.276 — 0.354 in)

reused: 9 — 11 mm (0.354 — 0.433 in)

(B)\*

replaced: 7.5 — 8.5 mm (0.295 — 0.335 in)

reused: 9.0 — 10.0 mm (0.354 — 0.394 in)

\*: With Air conditioner

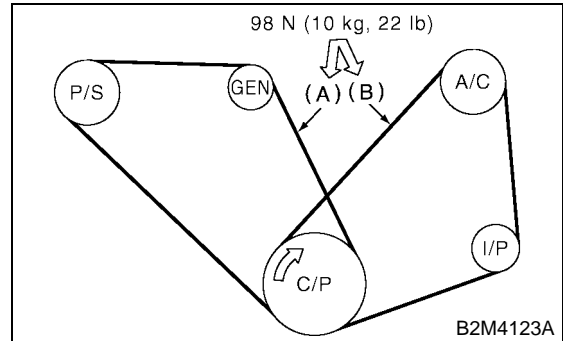

C/P Crankshaft pulley

GEN Generator

P/S Power steering oil pump pulley

A/C Air conditioning compressor pulley

I/P Idler pulley

## 13. Crankshaft Pulley

### A: REMOVAL

1) Remove V-belt. <Ref. to ME(DOHC TURBO)-43, REMOVAL, V-belt.>

2) Remove crankshaft pulley bolt. To lock crankshaft, use ST.

ST 499977100

CRANKSHAFT PULLEY WRENCH

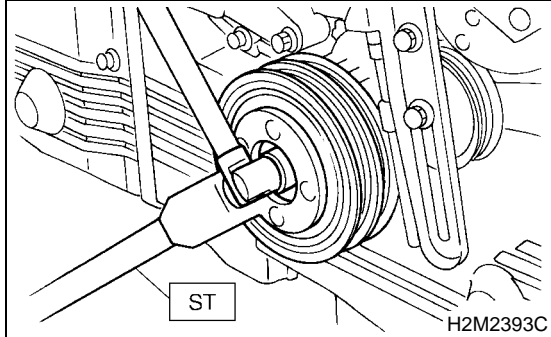

3) Remove crankshaft pulley.

### B: INSTALLATION

1) Install crankshaft pulley.

2) Install pulley bolt.

To lock crankshaft, use ST.

ST 499977100 CRANKSHAFT PULLEY WRENCH

(1) Clean the crankshaft pulley thread using an air gun.

(2) Apply engine oil to the crankshaft pulley bolt seat and thread.

(3) Tighten the bolts temporarily with tightening torque of 44 N·m (4.5 kgf·m, 33 ft·lb).

(4) Tighten the crankshaft pulley bolts.

**Tightening torque:**

**177 N·m (18.0 kgf·m, 130.2 ft·lb)**

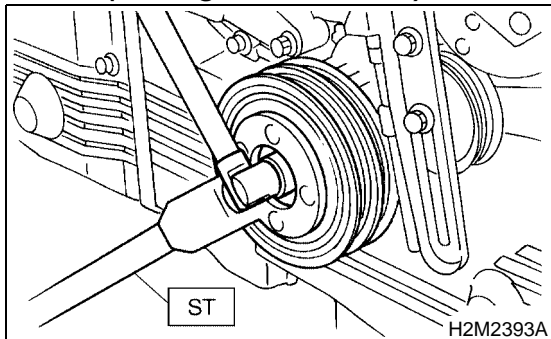

3) Confirm that the tightening angle of the crankshaft pulley bolt is 65 degrees or more. If not, conduct the following procedures (1) through (4).

(1) Replace the crankshaft pulley bolts and clean them.

**Crankshaft pulley bolt:**

**12369AA011**

(2) Clean the crankshaft thread using an air gun.

(3) Tighten the bolts temporarily with tightening torque of 44 N·m (4.5 kgf·m, 33 ft·lb).

(4) Tighten the crankshaft pulley bolts keeping them in an angle between 65 degrees and 75 degrees.

**CAUTION:**

**Conduct the tightening procedures by confirming the turning angle of the crankshaft pulley bolt referring to the gauge indicated on the belt cover.**

4) Install A/C belt tensioner.

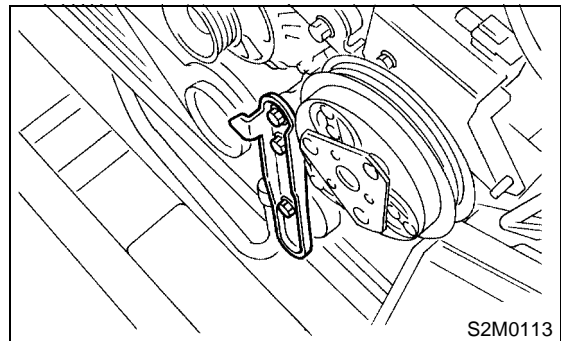

5) Install A/C belt.

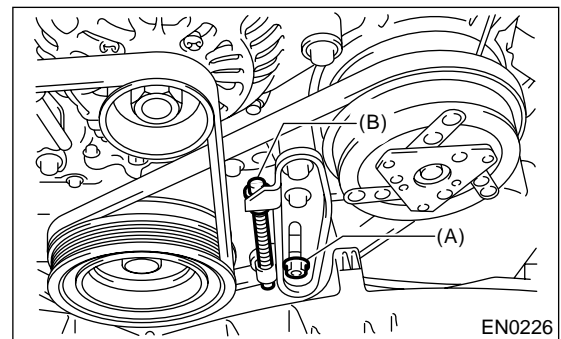

### C: INSPECTION

1) Make sure the V-belt is not worn or otherwise damaged.

2) Check the tension of the belt. <Ref. to ME(DOHC TURBO)-44, INSPECTION, V-belt.>

## 14. Belt Cover

### A: REMOVAL

- 1) Remove V-belt. <Ref. to ME(DOHC TURBO)-43, REMOVAL, V-belt.>
- 2) Remove crankshaft pulley. <Ref. to ME(DOHC TURBO)-45, REMOVAL, Crankshaft Pulley.>
- 3) Remove left-hand belt cover (A).
- 4) Remove right-hand belt cover (B).
- 5) Remove front belt cover (C).

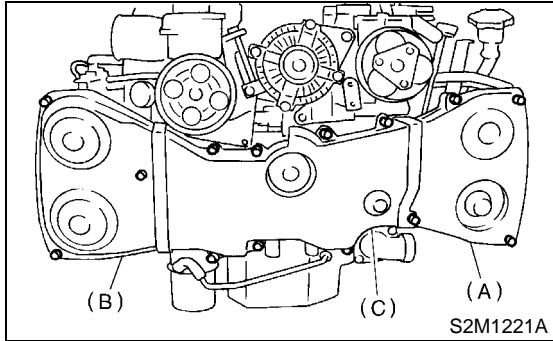

### B: INSTALLATION

- 1) Install front belt cover (C).

#### *Tightening torque:*

**5 N·m (0.5 kgf-m, 3.6 ft-lb)**

- 2) Install right-hand belt cover (B).

#### *Tightening torque:*

**5 N·m (0.5 kgf-m, 3.6 ft-lb)**

- 3) Install left-hand belt cover (A).

#### *Tightening torque:*

**5 N·m (0.5 kgf-m, 3.6 ft-lb)**

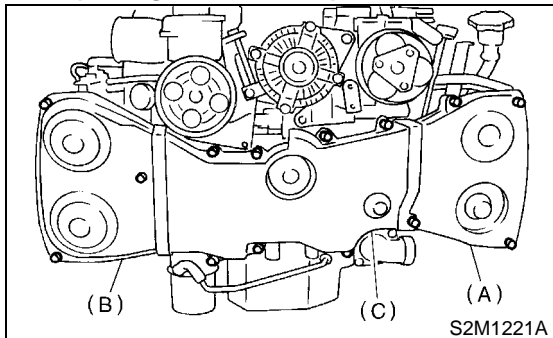

- 4) Install crankshaft pulley. <Ref. to ME(DOHC TURBO)-45, INSTALLATION, Crankshaft Pulley.>
- 5) Install V-belt. <Ref. to ME(DOHC TURBO)-43, INSTALLATION, V-belt.>

### C: INSPECTION

Make sure the cover is not damaged.

## 15. Timing Belt Assembly

### A: REMOVAL

#### 1. TIMING BELT

- 1) Remove V-belt. <Ref. to ME(DOHC TURBO)-43, REMOVAL, V-belt.>
- 2) Remove crankshaft pulley. <Ref. to ME(DOHC TURBO)-45, REMOVAL, Crankshaft Pulley.>
- 3) Remove belt cover. <Ref. to ME(DOHC TURBO)-46, REMOVAL, Belt Cover.>
- 4) Remove timing belt guides.

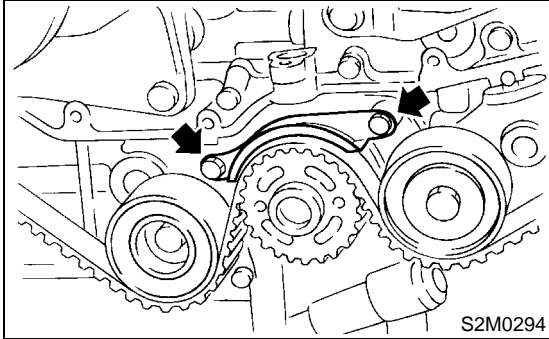

- 5) If alignment mark and/or arrow mark (which indicates rotation direction) on timing belt fade away, put new marks before removing timing belt as follows:

(1) Turn crankshaft using ST, and align alignment marks on crankshaft sprocket, left-hand intake camshaft sprocket, left-hand exhaust camshaft sprocket, right-hand intake camshaft sprocket and right hand exhaust camshaft sprocket with notches of belt cover and cylinder block.

ST 499987500 CRANKSHAFT SOCKET

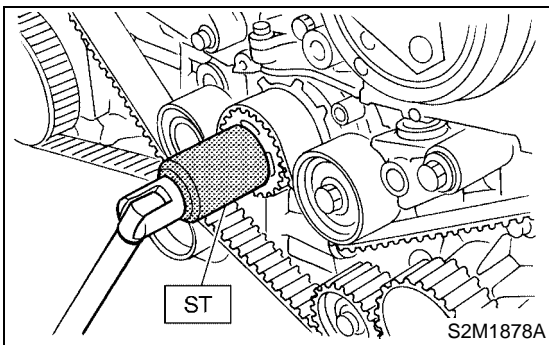

- (2) Using white paint, put alignment and/or arrow marks on timing belts in relation to the sprockets.

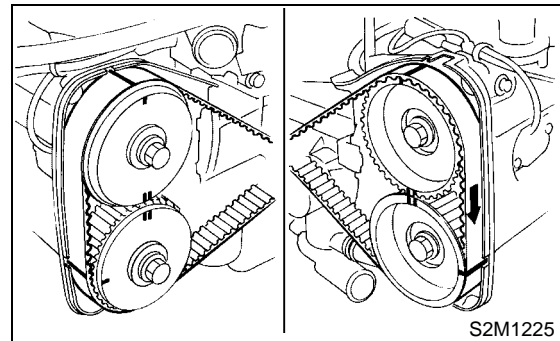
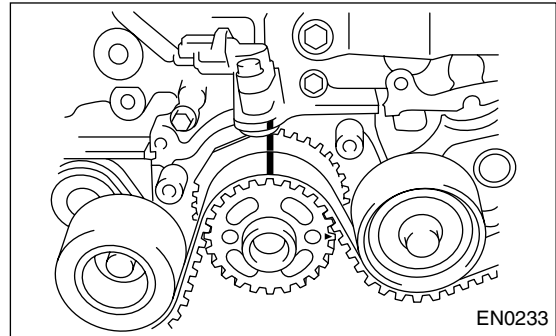

**Z<sub>1</sub>: 54.5 tooth length**

**Z<sub>2</sub>: 51 tooth length**

**Z<sub>3</sub>: 28 tooth length**

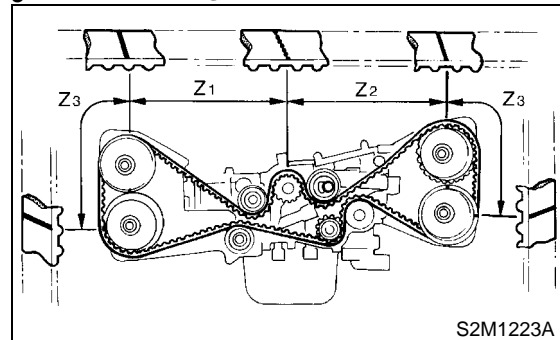

- 6) Remove belt idler (A).

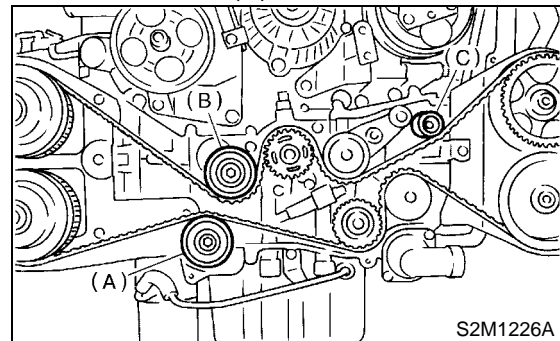

- 7) Remove timing belt.



# TIMING BELT ASSEMBLY

## MECHANICAL

### CAUTION:

After timing belt has been removed, never rotate intake and exhaust, camshaft sprocket. If camshaft sprocket is rotated, the intake and exhaust valve heads strike together and valve stems are bent.

### 2. BELT IDLER AND AUTOMATIC BELT TENSION ADJUSTER ASSEMBLY

1) Remove belt idler (B) and (C).

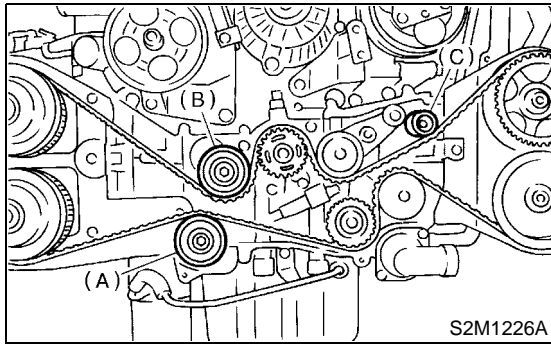

2) Remove belt idler No. 2.

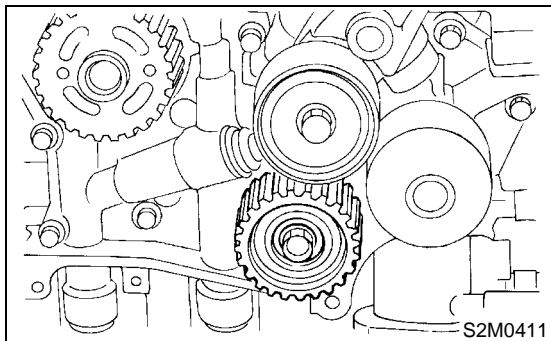

3) Remove automatic belt tension adjuster assembly.

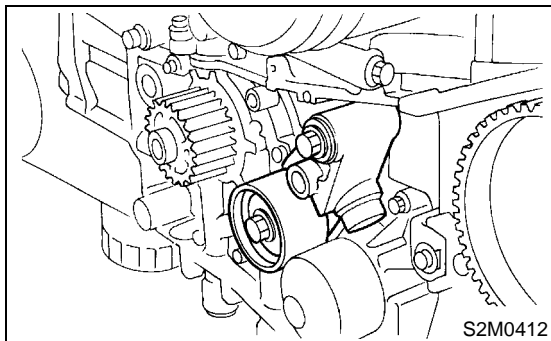

### B: INSTALLATION

#### 1. AUTOMATIC BELT TENSION ADJUSTER ASSEMBLY AND BELT IDLER

1) Preparation for installation of automatic belt tension adjuster assembly:

#### CAUTION:

- Always use a vertical type pressing tool to move the adjuster rod down.
- Do not use a lateral type vise.
- Push adjuster rod vertically.
- Be sure to slowly move the adjuster rod down applying a pressure of 294 N (30 kgf, 66 lb).
- Press-in the push adjuster rod gradually taking more than three minutes.
- Do not allow press pressure to exceed 9,807 N (1,000 kgf, 2,205 lb).
- Press the adjuster rod as far as the end surface of the cylinder. Do not press the adjuster rod into the cylinder. Doing so may damage the cylinder.
- Do not release press pressure until stopper pin is completely inserted.

(1) Attach the automatic belt tension adjuster assembly to the vertical pressing tool.

(2) Slowly move the adjuster rod down with a pressure of 294 N (30 kgf, 66 lb) until the adjuster rod is aligned with the stopper pin hole in the cylinder.

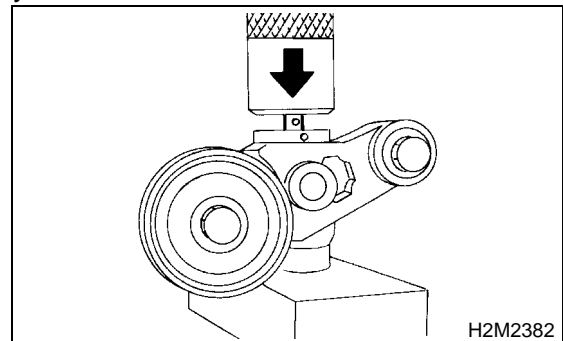

(3) With a 2 mm (0.08 in) dia. stopper pin or a 2 mm (0.08 in) (nominal) dia. hex bar wrench inserted into the stopper pin hole in the cylinder, secure the adjuster rod.

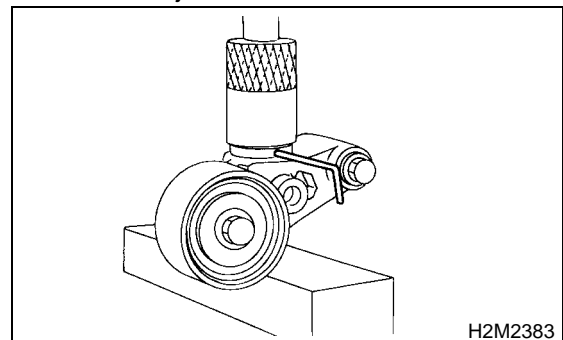

2) Install automatic belt tension adjuster assembly.

**Tightening torque:**

**39 N·m (4.0 kgf·m, 28.9 ft-lb)**

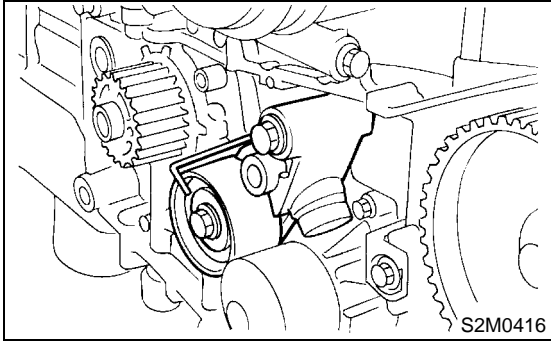

3) Install belt idler No. 2.

**Tightening torque:**

**39 N·m (4.0 kgf·m, 28.9 ft-lb)**

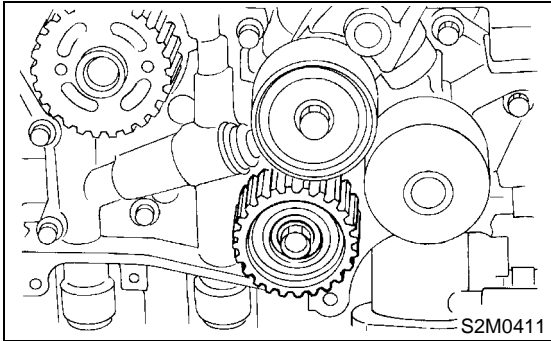

4) Install belt idler.

**Tightening torque:**

**39 N·m (4.0 kgf·m, 28.9 ft-lb)**

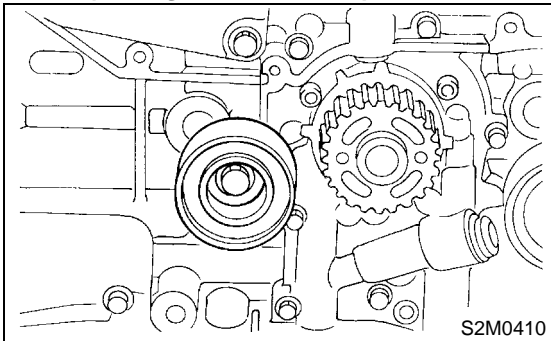

## 2. TIMING BELT

1) Preparation for installation of automatic belt tension adjuster assembly. <Ref. to ME(DOHC TURBO)-48, AUTOMATIC BELT TENSION ADJUSTER ASSEMBLY AND BELT IDLER, Timing Belt Assembly.>

2) Crankshaft and camshaft sprocket alignment.

(1) Align mark (A) on crankshaft sprocket with mark on the oil pump cover at cylinder block.

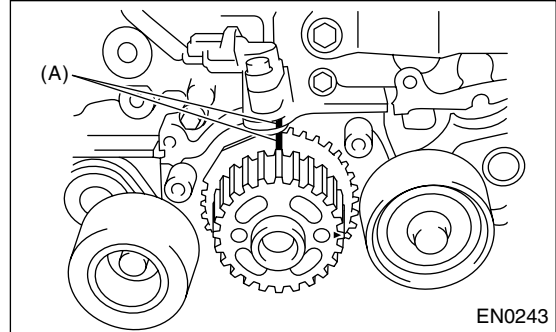

(2) Align single line mark (A) on right-hand exhaust camshaft sprocket with notch (B) on belt cover.

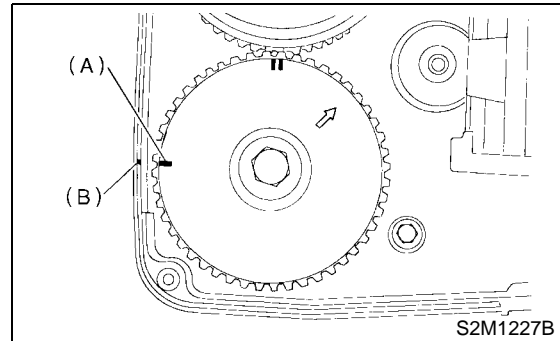

(3) Align single line mark (A) on right-hand intake camshaft sprocket with notch (B) on belt cover.

(Make sure double lines (C) on intake camshaft and exhaust camshaft sprockets are aligned.)

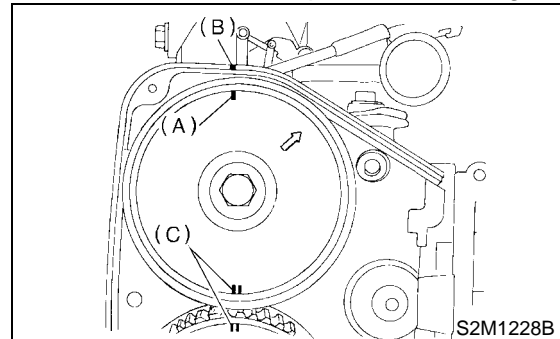

# TIMING BELT ASSEMBLY

## MECHANICAL

(4) Align single line mark (A) on left-hand exhaust camshaft sprocket with notch (B) on belt cover by turning sprocket counterclockwise (as viewed from front of engine).

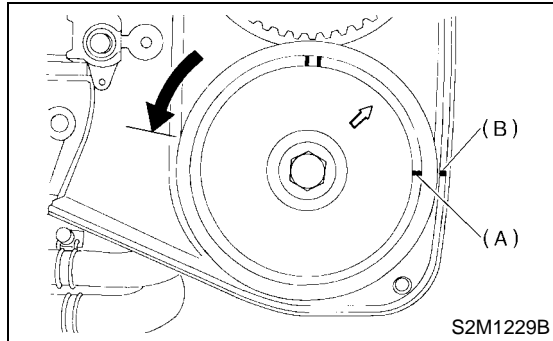

(5) Align single line mark (A) on left-hand intake camshaft sprocket with notch (B) on belt cover by turning sprocket clockwise (as viewed from front of engine).

Ensure double lines (C) on intake and exhaust camshaft sprockets are aligned.

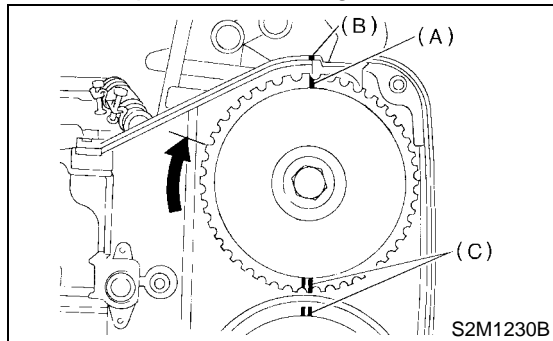

(6) Ensure camshaft and crankshaft sprockets are positioned properly.

# TIMING BELT ASSEMBLY

MECHANICAL

## CAUTION:

- Intake and exhaust camshafts for this DOHC engine can be independently rotated with timing belts removed. As can be seen from the figure, if intake and exhaust valves are lifted simultaneously, their heads will interfere with each other, resulting in bent valves.

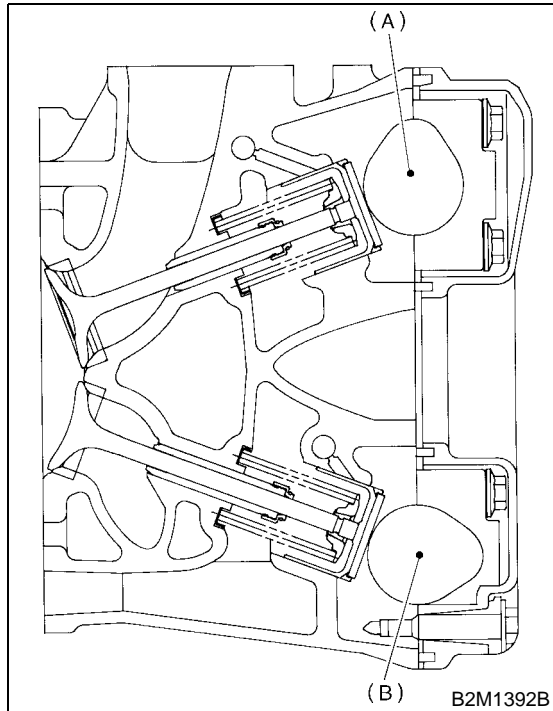

(A) Intake camshaft  
(B) Exhaust camshaft

- When timing belts are not installed, four camshafts are held at the “zero-lift” position, where all cams on camshafts do not push intake and exhaust valves down. (Under this condition, all valves remain unlifted.)
- When camshafts are rotated to install timing belts, #2 intake and #4 exhaust cam of left-hand camshafts are held to push their corresponding valves down. (Under this condition, these valves are held lifted.) Right-side camshafts are held so that their cams do not push valves down.
- Left-hand camshafts must be rotated from the “zero-lift” position to the position where timing belt is to be installed at as small an angle as possible, in order to prevent mutual interference of intake and exhaust valve heads.
- Do not allow camshafts to rotate in the direction shown in the figure as this causes both intake and exhaust valves to lift simultaneously, resulting in interference with their heads.

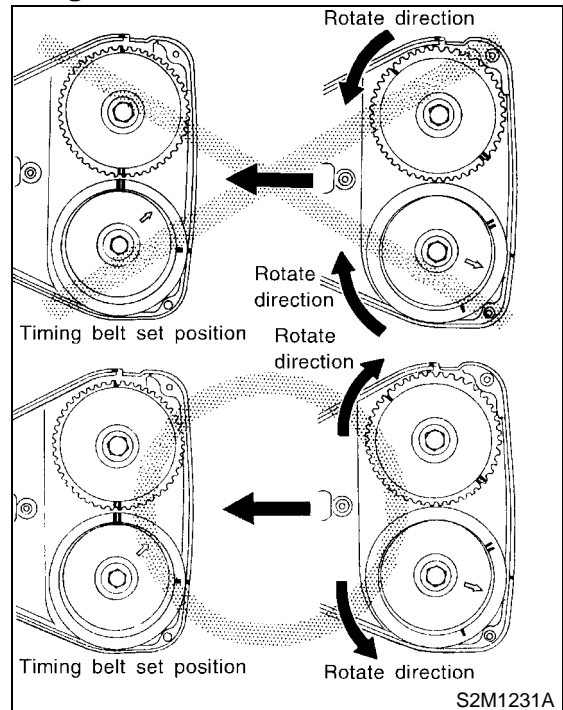

# TIMING BELT ASSEMBLY

MECHANICAL

## 3) Installation of timing belt

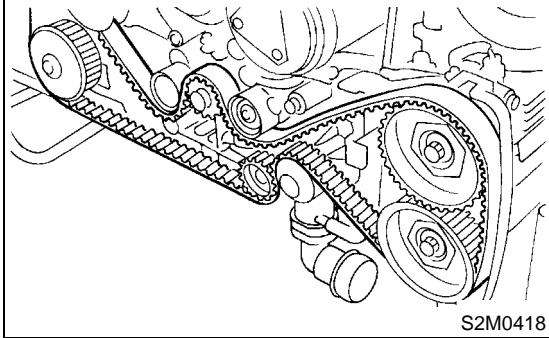

Align alignment mark on timing belt with marks on sprockets in the alphabetical order shown in figure. While aligning marks, position timing belt properly.

### CAUTION:

- Disengagement of more than three timing belt teeth may result in interference between the valve and piston.
- Ensure belt's rotating direction is correct.

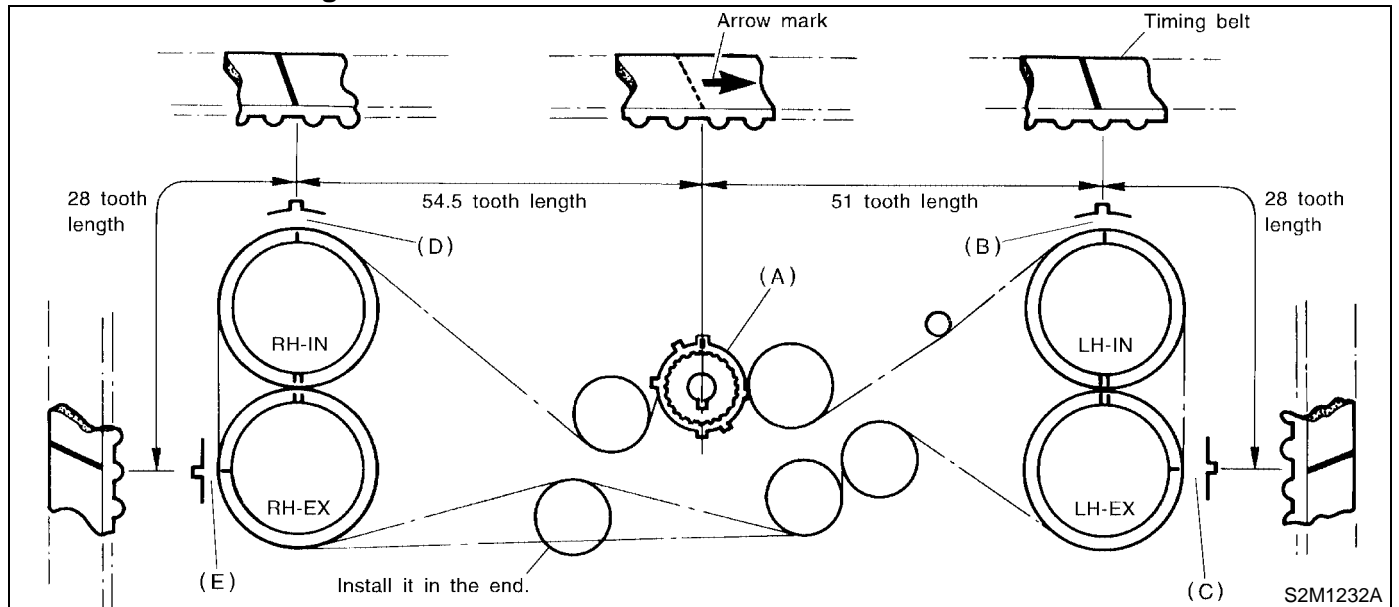

4) Install belt idlers.

**Tightening torque:**

**39 N·m (4.0 kgf·m, 28.9 ft·lb)**

**CAUTION:**

**Make sure that the marks on timing belt and sprockets are aligned.**

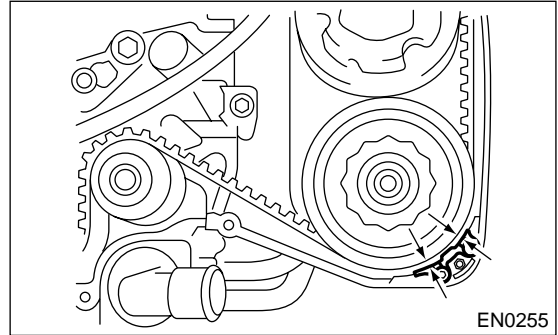
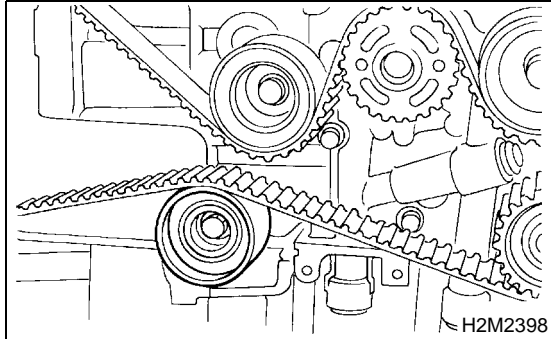

5) After ensuring that the marks on timing belt and sprockets are aligned, remove stopper pin from tensioner adjuster.

6) Install timing belt guide.

(1) Temporarily tighten remaining bolts.

(2) Check and adjust clearance between timing belt and timing belt guide.

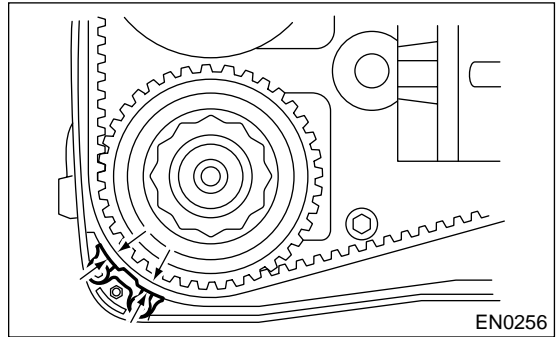

(3) Tighten remaining bolts.

**Clearance:**

**1.0±0.5 mm (0.039±0.020 in)**

**Tightening torque:**

**9.8 N·m (1.0 kgf·m, 7.2 ft·lb)**

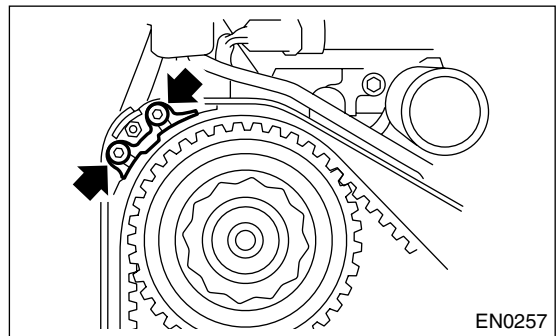
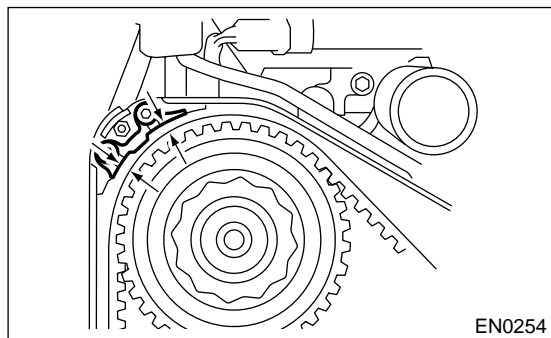
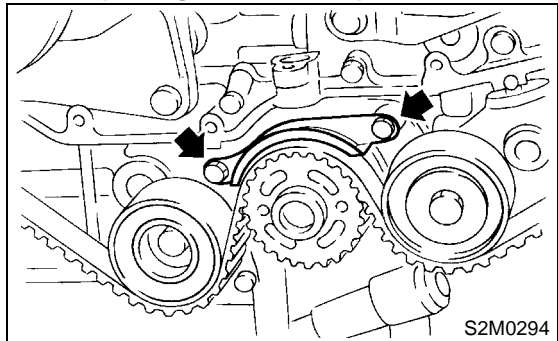
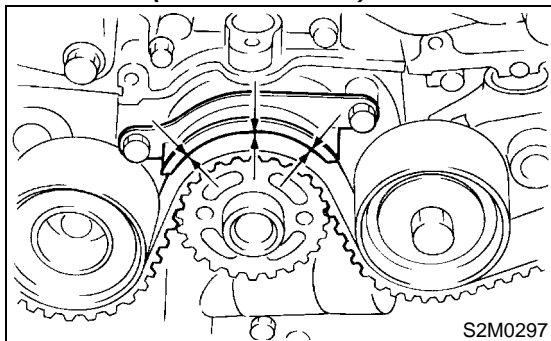

# TIMING BELT ASSEMBLY

MECHANICAL

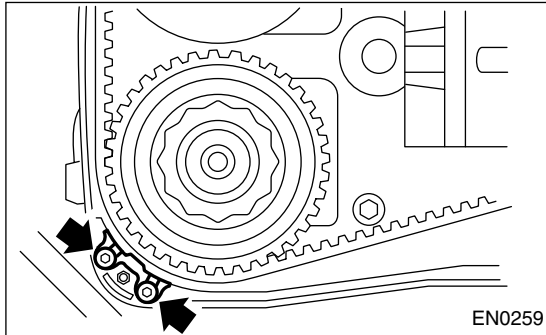
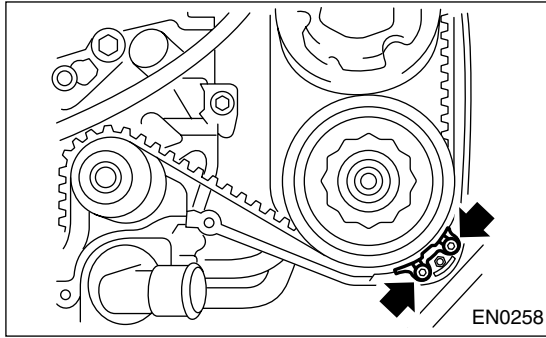

- 7) Install belt cover. <Ref. to ME(DOHC TURBO)-46, INSTALLATION, Belt Cover.>
- 8) Install crankshaft pulley. <Ref. to ME(DOHC TURBO)-45, REMOVAL, Crankshaft Pulley.>
- 9) Install V-belt. <Ref. to ME(DOHC TURBO)-43, INSTALLATION, V-belt.>

## C: INSPECTION

### 1. TIMING BELT

- 1) Check timing belt teeth for breaks, cracks, and wear. If any fault is found, replace belt.
- 2) Check the condition of back side of belt; if any crack is found, replace belt.

#### CAUTION:

- Be careful not to let oil, grease or coolant contact the belt. Remove quickly and thoroughly if this happens.
- Do not bend the belt sharply.

**Bending radius:  $h$**

**60 mm (2.36 in) or more**

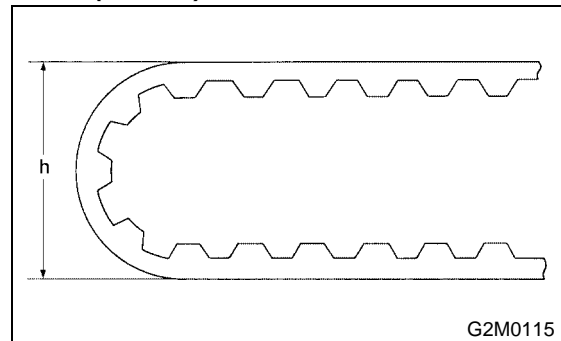

### 2. AUTOMATIC BELT TENSION ADJUST-ER

- 1) Visually check oil seals for leaks, and rod ends for abnormal wear or scratches. If necessary, replace automatic belt tension adjuster assembly.

#### CAUTION:

**Slight traces of oil at rod's oil seal does not indicate a problem.**

- 2) Check that the adjuster rod does not move when a pressure of 294 N (30 kgf, 66 lb) is applied to it. This is to check adjuster rod stiffness.
- 3) If the adjuster rod is not stiff and moves freely when applying 294 N (30 kgf, 66 lb), check it using the following procedures:

- (1) Slowly press the adjuster rod down to the end surface of the cylinder. Repeat this motion 2 or 3 times.
- (2) With the adjuster rod moved all the way up, apply a pressure of 294 N (30 kgf, 66 lb) to it. Check adjuster rod stiffness.
- (3) If the adjuster rod is not stiff and moves down, replace the automatic belt tension adjuster assembly with a new one.

#### CAUTION:

- Always use a vertical type pressing tool to move the adjuster rod down.
- Do not use a lateral type vise.
- Push adjuster rod vertically.

- Press-in the push adjuster rod gradually taking more than three minutes.
- Do not allow press pressure to exceed 9,807 N (1,000 kgf, 2,205 lb).
- Press the adjuster rod as far as the end surface of the cylinder. Do not press the adjuster rod into the cylinder. Doing so may damage the cylinder.

4) Measure the extension of rod beyond the body. If it is not within specifications, replace with a new one.

**Rod extension: H**

**$5.7\pm 0.5$  mm ( $0.224\pm 0.020$  in)**

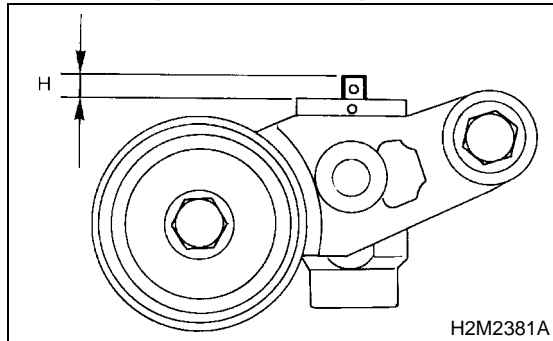

### 3. BELT TENSION PULLEY

- 1) Check mating surfaces of timing belt and contact point of adjuster rod for abnormal wear or scratches. Replace belt tension pulley if faulty.
- 2) Check belt tension pulley for smooth rotation. Replace if noise or excessive play is noted.
- 3) Check belt tension pulley for grease leakage.

### 4. BELT IDLER

- 1) Check idler for smooth rotation. Replace if noise or excessive play is noted.
- 2) Check outer contacting surfaces of idler pulley for abnormal wear and scratches.
- 3) Check idler for grease leakage.



# CAMSHAFT SPROCKET

MECHANICAL

## 16. Camshaft Sprocket

### A: REMOVAL

- 1) Remove V-belt. <Ref. to ME(DOHC TURBO)-43, REMOVAL, V-belt.>
- 2) Remove crankshaft pulley. <Ref. to ME(DOHC TURBO)-45, REMOVAL, Crankshaft Pulley.>
- 3) Remove belt cover. <Ref. to ME(DOHC TURBO)-46, REMOVAL, Belt Cover.>
- 4) Remove timing belt assembly. <Ref. to ME(DOHC TURBO)-47, REMOVAL, Timing Belt Assembly.>
- 5) Remove camshaft position sensor. <Ref. to FU(DOHC TURBO)-29, REMOVAL, Camshaft Position Sensor.>
- 6) Remove camshaft sprockets. To lock camshaft, use ST.

ST 499207400 CAMSHAFT SPROCKET WRENCH

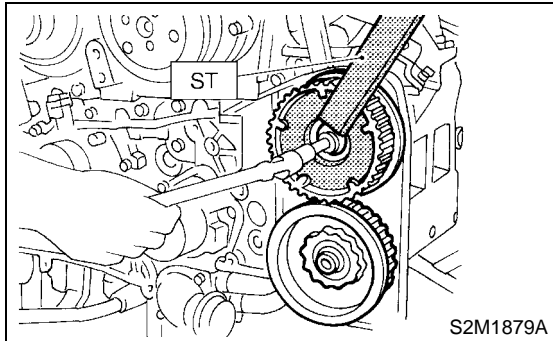

### B: INSTALLATION

- 1) Install camshaft sprocket No. 1. and No. 2. To lock camshaft, use ST.  
ST 499207100 CAMSHAFT SPROCKET WRENCH

#### *Tightening torque:*

**98 N·m (10 kgf·m, 72.4 ft·lb)**

#### **CAUTION:**

**Do not confuse left and right side camshaft sprockets during installation. The camshaft sprocket No. 2 is identified by a projection used to monitor camshaft position sensor.**

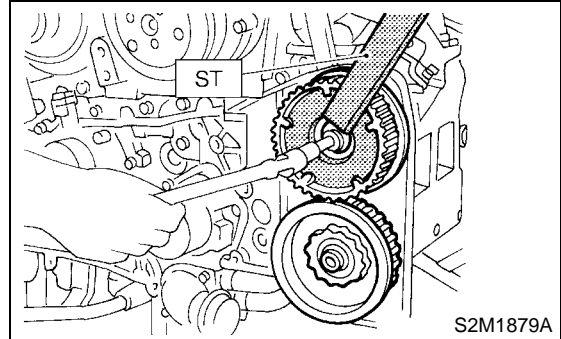

- 2) Install camshaft position sensor. <Ref. to FU(DOHC TURBO)-29, INSTALLATION, Camshaft Position Sensor.>
- 3) Install timing belt assembly. <Ref. to ME(DOHC TURBO)-48, INSTALLATION, Timing Belt Assembly.>
- 4) Install belt cover. <Ref. to ME(DOHC TURBO)-46, INSTALLATION, Belt Cover.>
- 5) Install crankshaft pulley. <Ref. to ME(DOHC TURBO)-45, INSTALLATION, Crankshaft Pulley.>
- 6) Install V-belt. <Ref. to ME(DOHC TURBO)-43, INSTALLATION, V-belt.>

### C: INSPECTION

- 1) Check sprocket teeth for abnormal wear and scratches.
- 2) Make sure there is no free play between sprocket and key.
- 3) Check crankshaft sprocket notch for sensor for damage and contamination of foreign matter.

## 17.Crankshaft Sprocket

### A: REMOVAL

- 1) Remove V-belt. <Ref. to ME(DOHC TURBO)-43, REMOVAL, V-belt.>
- 2) Remove crankshaft pulley. <Ref. to ME(DOHC TURBO)-45, REMOVAL, Crankshaft Pulley.>
- 3) Remove belt cover. <Ref. to ME(DOHC TURBO)-46, REMOVAL, Belt Cover.>
- 4) Remove timing belt assembly. <Ref. to ME(DOHC TURBO)-47, REMOVAL, Timing Belt Assembly.>
- 5) Remove camshaft sprocket. <Ref. to ME(DOHC TURBO)-56, REMOVAL, Camshaft Sprocket.>
- 6) Remove crankshaft sprocket.

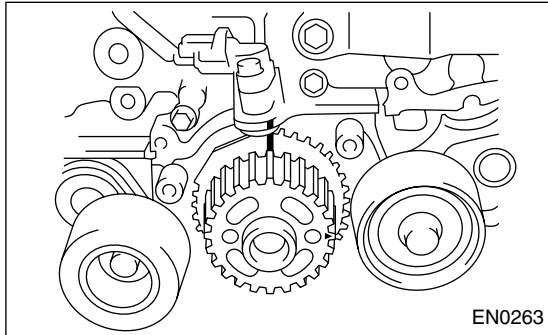

### B: INSTALLATION

- 1) Install crankshaft sprocket.

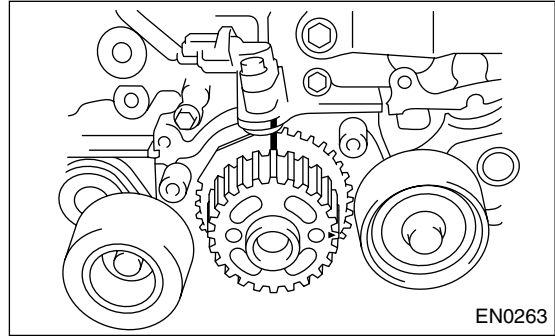

- 2) Install camshaft sprocket. <Ref. to ME(DOHC TURBO)-56, INSTALLATION, Camshaft Sprocket.>
- 3) Install timing belt assembly. <Ref. to ME(DOHC TURBO)-48, INSTALLATION, Timing Belt Assembly.>
- 4) Install belt cover. <Ref. to ME(DOHC TURBO)-46, INSTALLATION, Belt Cover.>
- 5) Install crankshaft pulley. <Ref. to ME(DOHC TURBO)-45, INSTALLATION, Crankshaft Pulley.>
- 6) Install V-belt. <Ref. to ME(DOHC TURBO)-43, INSTALLATION, V-belt.>

### C: INSPECTION

- 1) Check sprocket teeth for abnormal wear and scratches.
- 2) Make sure there is no free play between sprocket and key.
- 3) Check crankshaft sprocket notch for sensor for damage and contamination of foreign matter.

# CAMSHAFT

MECHANICAL

## 18. Camshaft

### A: REMOVAL

- 1) Remove V-belt. <Ref. to ME(DOHC TURBO)-43, INSTALLATION, V-belt.>
- 2) Remove crankshaft pulley. <Ref. to ME(DOHC TURBO)-45, REMOVAL, Crankshaft Pulley.>
- 3) Remove belt cover. <Ref. to ME(DOHC TURBO)-46, REMOVAL, Belt Cover.>
- 4) Remove timing belt assembly. <Ref. to ME(DOHC TURBO)-47, REMOVAL, Timing Belt Assembly.>
- 5) Remove camshaft sprocket. <Ref. to ME(DOHC TURBO)-56, REMOVAL, Camshaft Sprocket.>
- 6) Remove crankshaft sprocket. <Ref. to ME(DOHC TURBO)-57, REMOVAL, Crankshaft Sprocket.>
- 7) Remove left-hand belt cover No. 2.

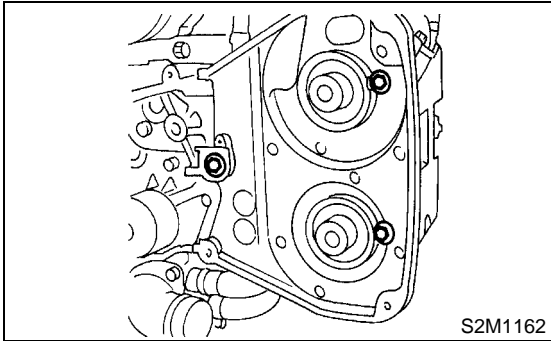

- 8) Remove right-hand belt cover No.2.

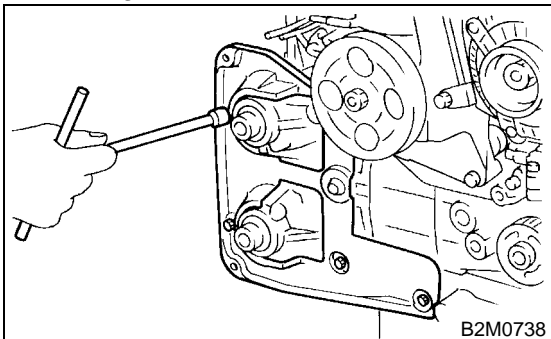

- 9) Remove tensioner bracket.

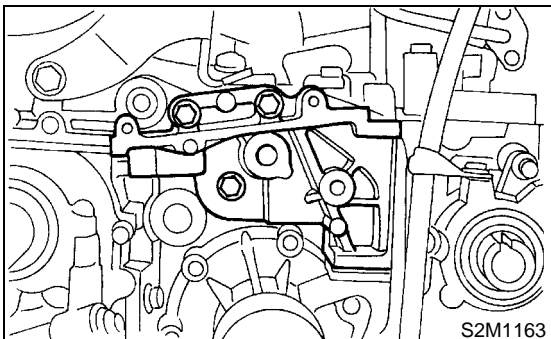

- 10) Remove oil level gauge guide. (LH side only)
- 11) Remove spark plug cord.
- 12) Remove rocker cover and gasket.

- 13) Loosen intake camshaft cap bolts equally, a little at a time in alphabetical sequence shown in figure.

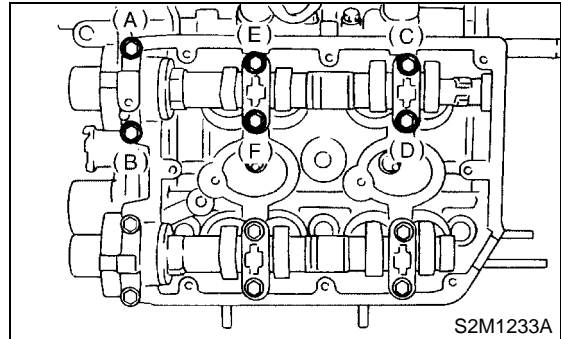

- 14) Remove camshaft caps and intake camshaft.
- 15) Loosen exhaust camshaft cap bolts equally, a little at a time in alphabetical sequence shown in figure.

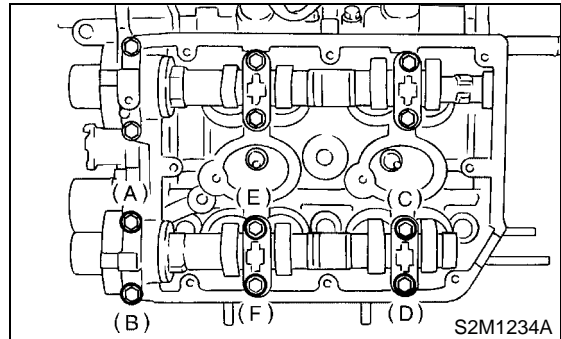

- 16) Remove camshaft caps and exhaust camshaft.

### CAUTION:

**Arrange camshaft caps in order so that they can be installed in their original positions.**

- 17) Similarly, remove right-hand camshafts and related parts.

## B: INSTALLATION

### 1) Camshaft installation

Apply engine oil to cylinder head at camshaft bearing location before installing camshaft. Install camshaft so that each valves is close to or in contact with "base circle" of cam lobe.

#### CAUTION:

- When camshafts are positioned as shown in figure, camshafts need to be rotated at a minimum to align with timing belt during installation.
- Right-hand camshaft need not be rotated when set at position shown in figure.
- Left-hand intake camshaft: Rotate 80° clockwise.
- Left-hand exhaust camshaft: Rotate 45° counterclockwise.

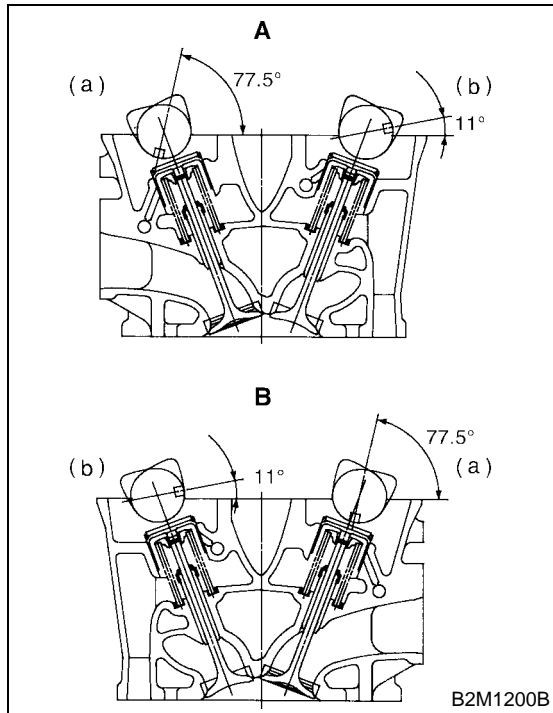

- A Left side cylinder head
- B Right side cylinder head
- (a) Intake camshaft
- (b) Exhaust camshaft

### 2) Camshaft cap installation

- (1) Apply fluid packing sparingly to cap mating surface.

#### CAUTION:

Do not apply fluid packing excessively. Failure to do so may cause excess packing to come out and flow toward oil seal, resulting in oil leaks.

#### Fluid packing:

**THREE BOND 1215 or equivalent**

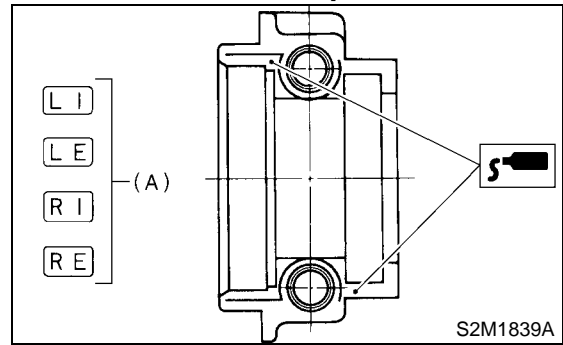

- (2) Apply engine oil to cap bearing surface and install cap on camshaft as shown by identification mark (A).

- (3) Gradually tighten cap in at least two stages in alphabetical sequence shown in figure, and then tighten to specified torque.

#### Tightening torque:

**20 N·m (2.0 kgf·m, 14.5 ft·lb)**

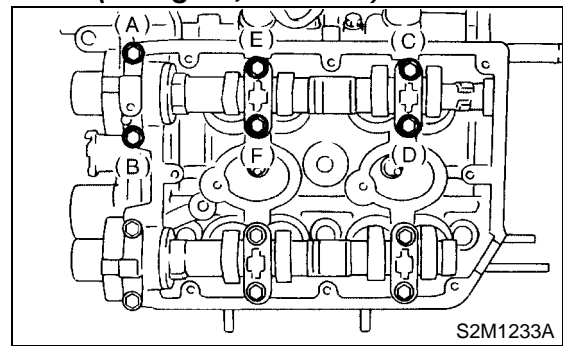

- (4) Similarly, tighten cap on exhaust side. After tightening cap, ensure camshaft rotates only slightly while holding it at "base" circle.

#### Tightening torque:

**20 N·m (2.0 kgf·m, 14.5 ft·lb)**

### 3) Camshaft oil seal installation

Apply grease to new oil seal lips and press onto front end of camshaft by using ST1 and ST2.

#### CAUTION:

Use a new oil seal.

- ST1 499587600 OIL SEAL INSTALLER
- ST2 499597200 OIL SEAL GUIDE

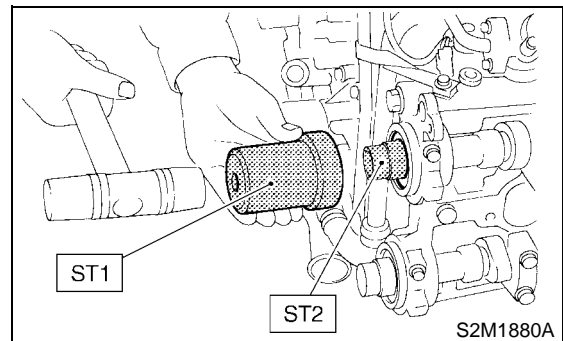

# CAMSHAFT

## MECHANICAL

### 4) Rocker cover installation

- (1) Install gasket on rocker cover. Install peripheral gasket and ignition coil gasket.
- (2) Apply fluid packing to four front open edges of peripheral gasket.

#### Fluid packing:

**THREE BOND 1215 or equivalent**

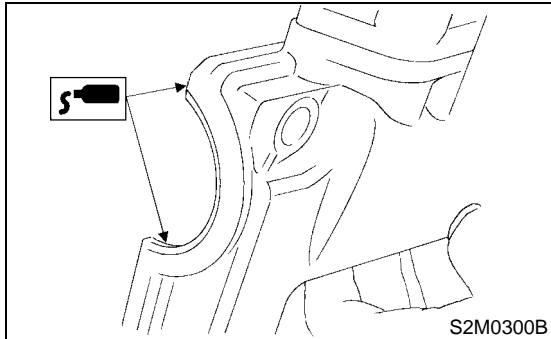

- (3) Install rocker cover on cylinder head. Ensure gasket is properly positioned during installation.

### 5) Install spark plug cord.

### 6) Similarly, install parts on right-hand side.

### 7) Install right-hand belt cover No. 2.

#### Tightening torque:

**5 N·m (0.5 kgf·m, 3.6 ft·lb)**

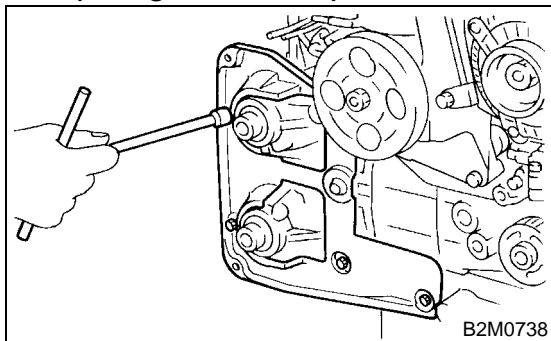

### 8) Install left-hand belt cover No. 2.

#### Tightening torque:

**5 N·m (0.5 kgf·m, 3.6 ft·lb)**

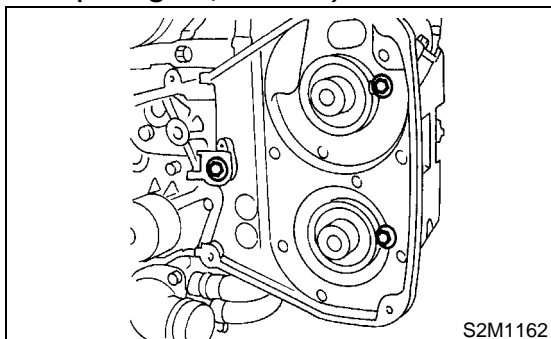

### 9) Install tensioner bracket.

#### Tightening torque:

**25± 3 N·m (2.5± 0.3 kg·m, 18.1± 2.2 ft·lb)**

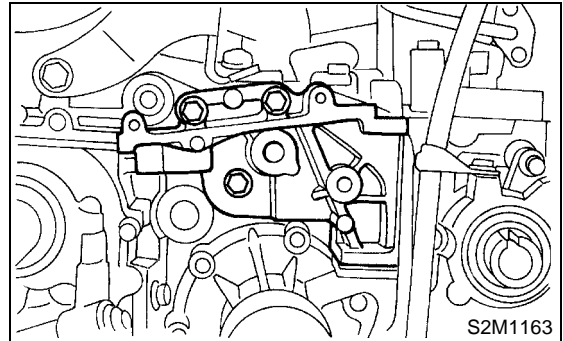

### 10) Install crankshaft sprocket. <Ref. to ME(DOHC TURBO)-56, INSTALLATION, Camshaft Sprocket.>

### 11) Install camshaft sprockets. <Ref. to ME(DOHC TURBO)-56, INSTALLATION, Camshaft Sprocket.>

### 12) Install timing belt assembly. <Ref. to ME(DOHC TURBO)-48, INSTALLATION, Timing Belt Assembly.>

### 13) Install belt cover. <Ref. to ME(DOHC TURBO)-46, INSTALLATION, Belt Cover.>

### 14) Install crankshaft pulley. <Ref. to ME(DOHC TURBO)-45, INSTALLATION, Crankshaft Pulley.>

### 15) Install V-belt. <Ref. to ME(DOHC TURBO)-43, INSTALLATION, V-belt.>

## C: INSPECTION

1) Measure the bend, and repair or replace if necessary.

**Limit:**

**0.020 mm (0.0008 in)**

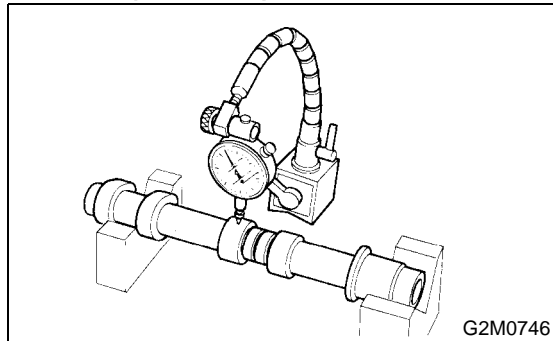

2) Check journal for damage and wear. Replace if faulty.

3) Measure outside diameter of camshaft journal. If the journal diameter is not as specified, check the oil clearance.

|          | Camshaft journal                         |   |
|----------|--|---|
|          | Front                                    | Center, rear                            |
| Standard | 37.946 — 37.9635<br>(1.4939 — 1.4946 in) | 29.946 — 29.963<br>(1.1790 — 1.1796 in) |

4) Measurement of the camshaft journal oil clearance

- (1) Clean the bearing caps and camshaft journals.
- (2) Place the camshafts on the cylinder head. (Without installing valve rocker.)
- (3) Place plastigauge across each of the camshaft journals.
- (4) Gradually tighten cap in at least two stages in alphabetical sequence shown in figure, and then tighten to specified torque.

**Tightening torque:**

**20 N·m (2.0 kgf·m, 14.5 ft·lb)**

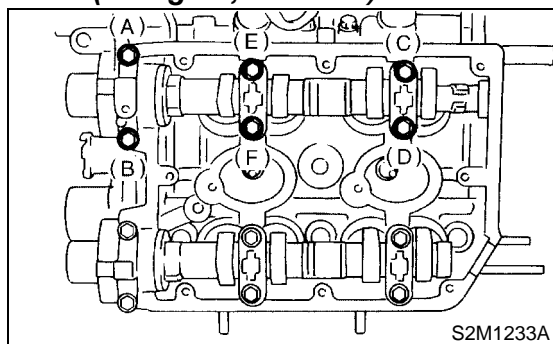

**CAUTION:**

**Do not turn the camshaft.**

- (5) Remove the bearing caps.

(6) Measure the widest point of the plastigauge on each journal.

If the oil clearance exceeds the limit, replace the camshaft. If necessary, replace the camshaft caps and cylinder head as a set.

**Standard:**

**0.037 — 0.072 mm (0.0015 — 0.0028 in)**

**Limit:**

**0.10 mm (0.0039 in)**

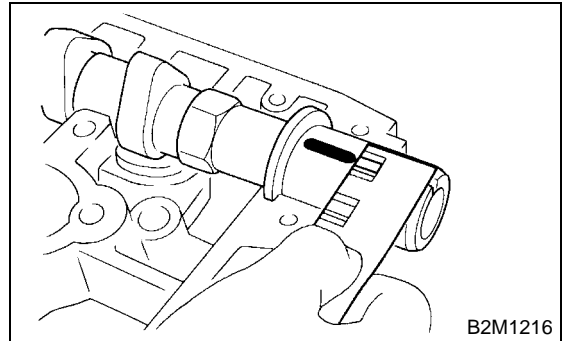

(7) Completely remove the plastigauge.

5) Check cam face condition; remove minor faults by grinding with oil stone. Measure the cam height H; replace if the limit has been exceeded.

**Cam height: H**

**Standard:**

**Intake:**

**46.25 — 46.35 mm (1.821 — 1.825 in)**

**Exhaust:**

**46.15 — 46.25 mm (1.817 — 1.821 in)**

**Limit:**

**Intake:**

**46.15 mm (1.817 in)**

**Exhaust:**

**46.05 mm (1.813 in)**

**Cam base circle diameter A:**

**37.0 mm (1.457 in)**

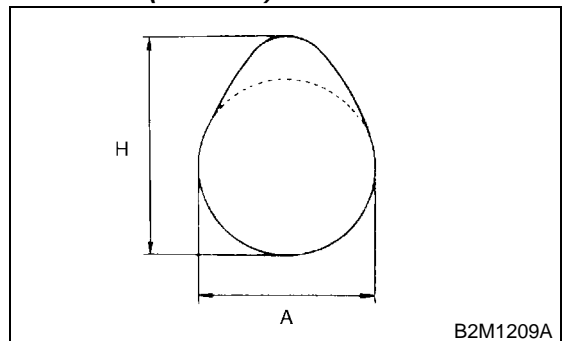

# CAMSHAFT

## MECHANICAL

---

6) Measure the thrust clearance of camshaft with dial gauge. If the clearance exceeds the limit, replace caps and cylinder head as a set. If necessary replace camshaft.

**Standard:**

*0.015 — 0.070 mm (0.0006 — 0.0028 in)*

**Limit:**

*0.1 mm (0.004 in)*

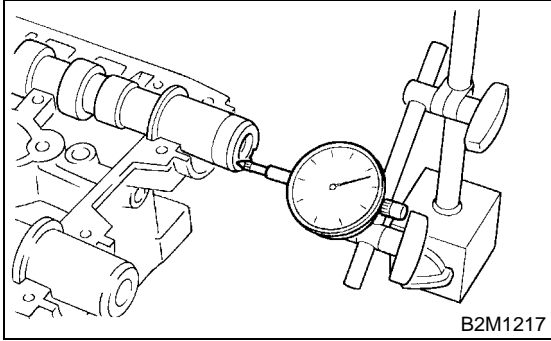

## 19. Cylinder Head Assembly

### A: REMOVAL

- 1) Remove V-belt. <Ref. to ME(DOHC TURBO)-43, REMOVAL, V-belt.>
- 2) Remove crankshaft pulley. <Ref. to ME(DOHC TURBO)-45, REMOVAL, Crankshaft Pulley.>
- 3) Remove belt cover. <Ref. to ME(DOHC TURBO)-46, REMOVAL, Belt Cover.>
- 4) Remove timing belt assembly. <Ref. to ME(DOHC TURBO)-47, REMOVAL, Timing Belt Assembly.>
- 5) Remove camshaft sprocket. <Ref. to ME(DOHC TURBO)-56, REMOVAL, Camshaft Sprocket.>
- 6) Remove intake manifold. <Ref. to FU(DOHC TURBO)-15, REMOVAL, Intake Manifold.>
- 7) Remove bolt which installs A/C compressor bracket on cylinder head.
- 8) Remove camshaft. <Ref. to ME(DOHC TURBO)-58, REMOVAL, Camshaft.>
- 9) Remove cylinder head bolts in alphabetical sequence shown in figure.

#### CAUTION:

Leave bolts (A) and (D) engaged by three or four threads to prevent cylinder head from falling.

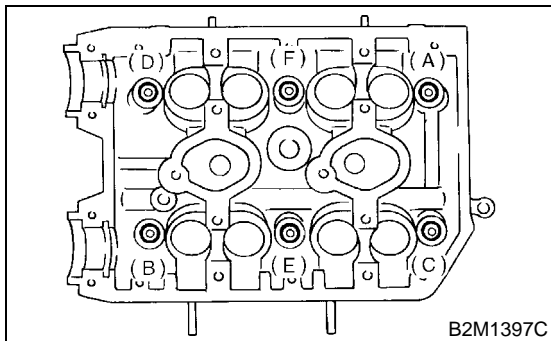

- 10) While tapping cylinder head with a plastic hammer, separate it from cylinder block. Remove bolts (A) and (D) to remove cylinder head.

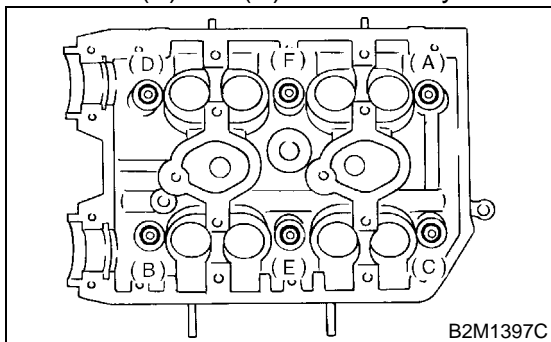

- 11) Remove cylinder head gasket.

#### CAUTION:

Do not scratch the mating surface of cylinder head and cylinder block.

- 12) Similarly, remove right side cylinder head.

### B: INSTALLATION

- 1) Install cylinder head and gaskets on cylinder block.

#### CAUTION:

- Use new cylinder head gaskets.
- Be careful not to scratch the mating surface of cylinder head and cylinder block.

- 2) Tighten cylinder head bolts.

(1) Apply a coat of engine oil to washers and bolt threads.

(2) Tighten all bolts to 29 N·m (3.0 kgf·m, 22 ft·lb) in alphabetical sequence.

Then tighten all bolts to 69 N·m (7.0 kgf·m, 51 ft·lb) in alphabetical sequence.

(3) Back off all bolts by 180° first; back them off by 180° again.

(4) Tighten bolts (A) and (B) to 34 N·m (3.5 kgf·m, 25 ft·lb).

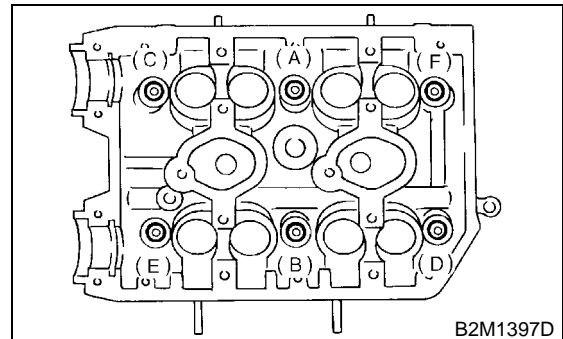

- (5) Tighten bolts (C), (D), (E) and (F) to 15 N·m (1.5 kgf·m, 11 ft·lb).

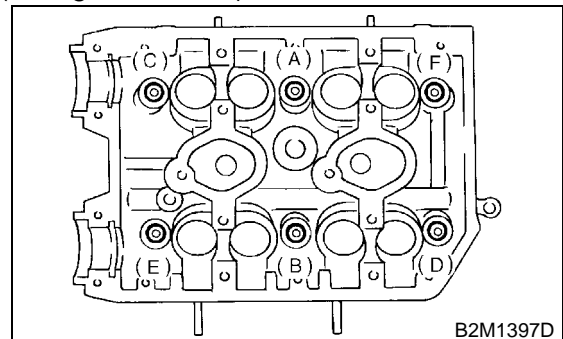

- (6) Tighten all bolts by 80 to 90° in alphabetical sequence.

#### CAUTION:

Do not tighten bolts more than 90°.

(7) Further tighten all bolts by 80 to 90° in alphabetical sequence.

#### CAUTION:

Ensure that the total “re-tightening angle” [in the two previous steps] do not exceed 180°.

3) Install camshaft. <Ref. to ME(DOHC TURBO)-59, INSTALLATION, Camshaft.>

4) Install A/C compressor bracket on cylinder head.



# CYLINDER HEAD ASSEMBLY

## MECHANICAL

- 5) Install intake manifold. <Ref. to FU(DOHC TURBO)-17, INSTALLATION, Intake Manifold.>
- 6) Install camshaft sprocket. <Ref. to ME(DOHC TURBO)-56, INSTALLATION, Camshaft Sprocket.>
- 7) Install timing belt assembly. <Ref. to ME(DOHC TURBO)-48, INSTALLATION, Timing Belt Assembly.>
- 8) Install belt cover. <Ref. to ME(DOHC TURBO)-46, INSTALLATION, Belt Cover.>
- 9) Install crankshaft pulley. <Ref. to ME(DOHC TURBO)-45, INSTALLATION, Crankshaft Pulley.>
- 10) Install V-belt. <Ref. to ME(DOHC TURBO)-43, INSTALLATION, V-belt.>

## C: DISASSEMBLY

- 1) Remove valve shims and valve lifters.
- 2) Compress the valve spring and remove the valve spring retainer key. Remove each valve and valve spring.

ST 498267600 CYLINDER HEAD TABLE  
ST 499718000 VALVE SPRING REMOVER

### CAUTION:

- Keep removed parts in order for re-installing in their original positions.
- Mark each valve to prevent confusion.
- Use extreme care not to damage the lips of the intake valve oil seals and exhaust valve oil seals.

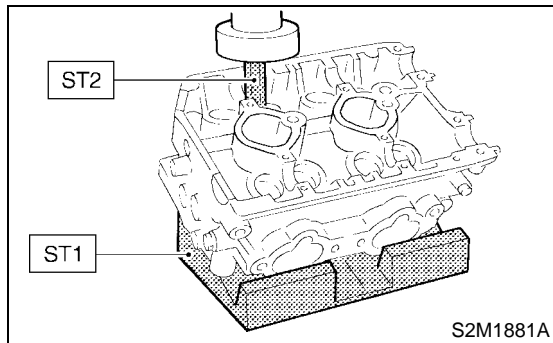

# CYLINDER HEAD ASSEMBLY

MECHANICAL

## D: ASSEMBLY

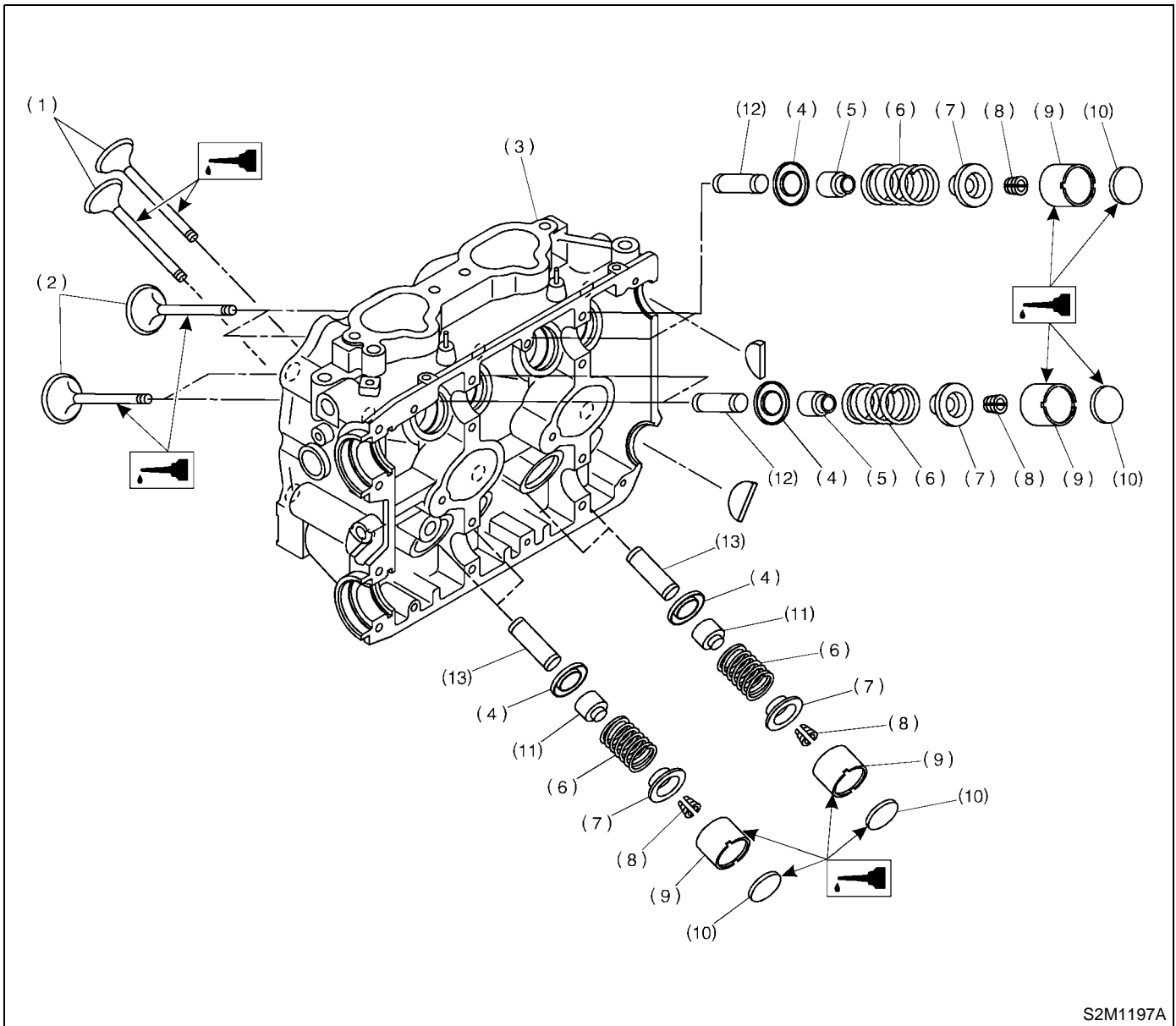

S2M1197A

- |                           |                  |                             |
|---------------------------|------------------|-----------------------------|
| (1) Exhaust valve         | (6) Valve spring | (11) Exhaust valve oil seal |
| (2) Intake valve          | (7) Retainer     | (12) Intake valve guide     |
| (3) Cylinder head         | (8) Retainer key | (13) Exhaust valve guide    |
| (4) Valve spring seat     | (9) Valve lifter |                             |
| (5) Intake valve oil seal | (10) Shim        |                             |

ME(DOHC TURBO)-65

# CYLINDER HEAD ASSEMBLY

## MECHANICAL

- 1) Installation of valve spring and valve
  - (1) Coat stem of each valve with engine oil and insert valve into valve guide.

### CAUTION:

When inserting valve into valve guide, use special care not to damage the oil seal lip.

- (2) Set cylinder head on ST1.
- (3) Install valve spring and retainer using ST2.

ST 498267600 CYLINDER HEAD TABLE  
ST 499718000 VALVE SPRING REMOVER

### CAUTION:

Be sure to install the valve springs with their close-coiled end facing the seat on the cylinder head.

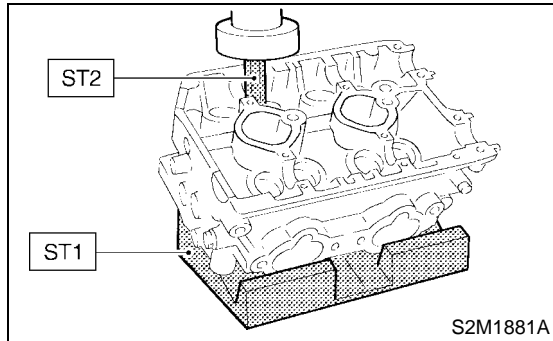

- (4) Compress valve spring and fit valve spring retainer key.
  - (5) After installing, tap valve spring retainers lightly with wooden hammer for better seating.
- 2) Apply oil to the surface of the valve lifter and valve shim.
  - 3) Install valve lifter and valve shim.

## E: INSPECTION

### 1. CYLINDER HEAD

- 1) Make sure that no crack or other damage exists. In addition to visual inspection, inspect important areas by means of red check.
- 2) Measure the warping of the cylinder head surface that mates with crankcase by using a straight edge (A) and thickness gauge (B). If the warping exceeds 0.05 mm (0.0020 in), re-grind the surface with a surface grinder.

#### Warping limit:

0.05 mm (0.0020 in)

#### Grinding limit:

0.3 mm (0.012 in)

#### Standard height of cylinder head:

127.5 mm (5.02 in)

### CAUTION:

Uneven torque for the cylinder head nuts can cause warping. When reassembling, pay special attention to the torque so as to tighten evenly.

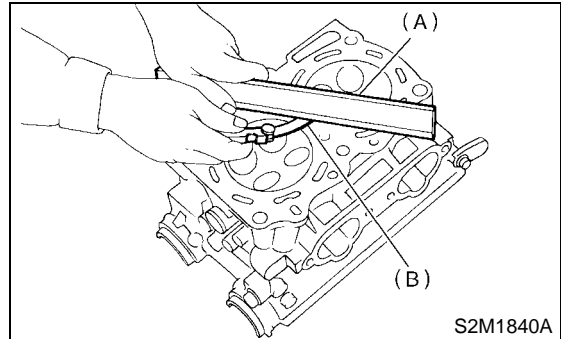

### 2. VALVE SEAT

Inspect intake and exhaust valve seats, and correct the contact surfaces with valve seat cutter if they are defective or when valve guides are replaced.

#### Valve seat width: *W*

##### Intake

###### Standard

1.0 mm (0.039 in)

###### Limit

1.7 mm (0.067 in)

##### Exhaust

###### Standard

1.5 mm (0.059 in)

###### Limit

2.2 mm (0.087 in)

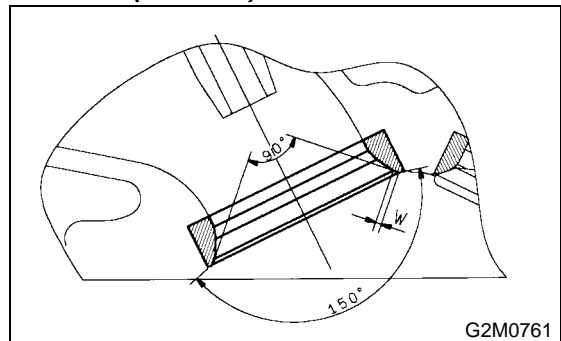

## 3. VALVE GUIDE

1) Check the clearance between valve guide and stem. The clearance can be checked by measuring the outside diameter of valve stem and the inside diameter of valve guide with outside and inside micrometers respectively.

**Clearance between the valve guide and valve stem:**

**Standard**

**Intake**

0.035 — 0.062 mm (0.0014 — 0.0024 in)

**Exhaust**

0.040 — 0.067 mm (0.0016 — 0.0026 in)

**Limit**

0.15 mm (0.0059 in)

2) If the clearance between valve guide and stem exceeds the limit, replace valve guide or valve itself whichever shows greater amount of wear. See following procedure for valve guide replacement.

**Valve guide inner diameter:**

6.000 — 6.012 mm (0.2362 — 0.2367 in)

**Valve stem outer diameters:**

**Intake**

5.950 — 5.965 mm (0.2343 — 0.2348 in)

**Exhaust**

5.945 — 5.960 mm (0.2341 — 0.2346 in)

(1) Place cylinder head on ST1 with the combustion chamber upward so that valve guides enter the holes in ST1.

(2) Insert ST2 into valve guide and press it down to remove valve guide.

ST1 498267600 CYLINDER HEAD TABLE  
ST2 499767200 VALVE GUIDE REMOVER

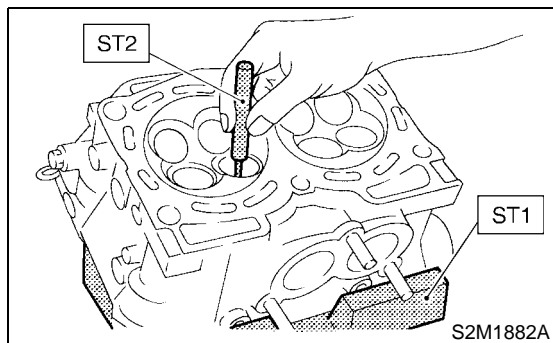

(3) Turn cylinder head upside down and place ST as shown in the figure.

ST 498767700 VALVE GUIDE ADJUSTER

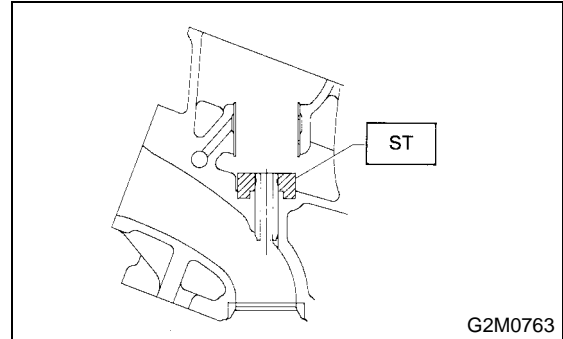

(4) Before installing new valve guide, make sure that neither scratches nor damages exist on the inside surface of the valve guide holes in cylinder head.

(5) Put new valve guide, coated with sufficient oil, in cylinder, and insert ST1 into valve guide. Press in until the valve guide upper end is flush with the upper surface of ST2.

ST1 499767200 VALVE GUIDE REMOVER  
ST2 498267700 VALVE GUIDE ADJUSTER

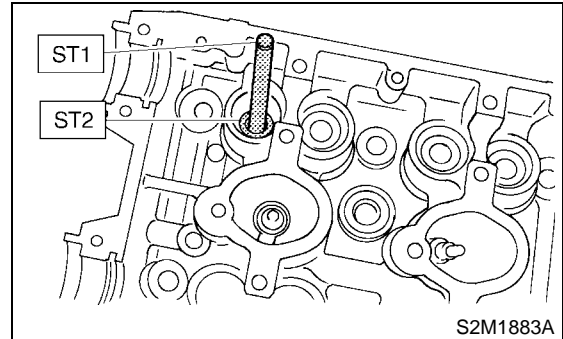

(6) Check the valve guide protrusion.

**Valve guide protrusion: L**

12.0 — 12.4 mm (0.472 — 0.488 in)

(7) Ream the inside of valve guide with ST. Gently rotate the reamer clockwise while pressing it lightly into valve guide, and return it also rotating clockwise. After reaming, clean valve guide to remove chips.

ST 499767400 VALVE GUIDE REAMER

**CAUTION:**

- Apply engine oil to the reamer when reaming.
- If the inner surface of the valve guide is torn, the edge of the reamer should be slightly ground with an oil stone.
- If the inner surface of the valve guide becomes lustrous and the reamer does not chip, use a new reamer or remedy the reamer.

(8) Recheck the contact condition between valve and valve seat after replacing valve guide.

# CYLINDER HEAD ASSEMBLY

MECHANICAL

## 4. INTAKE AND EXHAUST VALVE

1) Inspect the flange and stem of valve, and replace if damaged, worn, or deformed, or if "H" is less than the specified limit.

**H:**

**Intake**

**Standard**

**1.2 mm (0.047 in)**

**Limit**

**0.8 mm (0.031 in)**

**Exhaust**

**Standard**

**1.5 mm (0.059 in)**

**Limit**

**0.8 mm (0.031 in)**

**Valve overall length:**

**Intake**

**104.4 mm (4.110 in)**

**Exhaust**

**104.7 mm (4.122 in)**

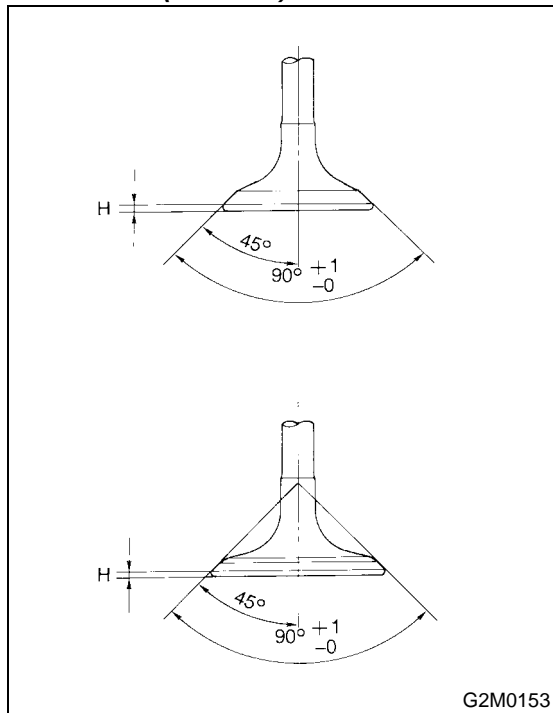

2) Put a small amount of grinding compound on the seat surface and lap the valve and seat surface. Install a new intake valve oil seal after lapping.

## 5. VALVE SPRINGS

1) Check valve springs for damage, free length, and tension. Replace valve spring if it is not to the specifications presented in the table.

2) To measure the squareness of the valve spring, stand the spring on a surface plate and measure its deflection at the top using a try square.

| Valve spring          |   |
|-----------------------|---|
| Free length           | 44.67 mm (1.7587 in)  |
| Tension/spring height | 220.7±15.7 N<br>(22.5 ± 1.6 kgf, 49.6±3.5 lb)/36.0 mm<br>(1.417 in) |
|                       | 510.9±25.5 N<br>(52.1±2.6 kgf, 114.9±5.7 lb)/26.6 mm<br>(1.047 in)  |
| Squareness            | 2.5°, 2.0 mm (0.079 in)   |

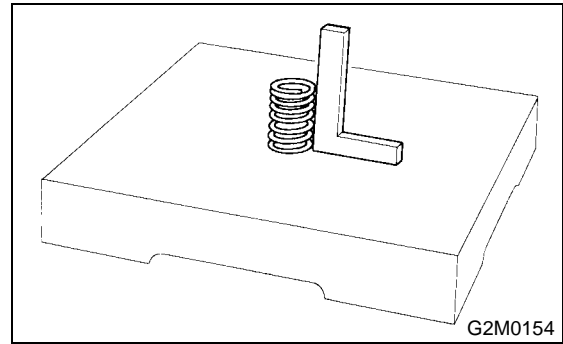

## 6. INTAKE AND EXHAUST VALVE OIL SEAL

Replace oil seal with new one, if lip is damaged or spring out of place, or when the surfaces of intake valve and valve seat are reconditioned or intake valve guide is replaced.

- 1) Place cylinder head on ST1.
- 2) Press in oil seal to the specified dimension indicated in the figure by using ST2.

ST1 498267600 CYLINDER HEAD TABLE  
 ST2 498857100 VALVE GUIDE REMOVER

### CAUTION:

- Apply engine oil to oil seal before force-fitting.
- Differentiate between intake valve oil seal and exhaust valve oil seal by noting their difference in color.

### Color of rubber part:

Intake [Black]  
 Exhaust [Brown]

### Color of spring part:

Intake [Silver]  
 Exhaust [Silver]

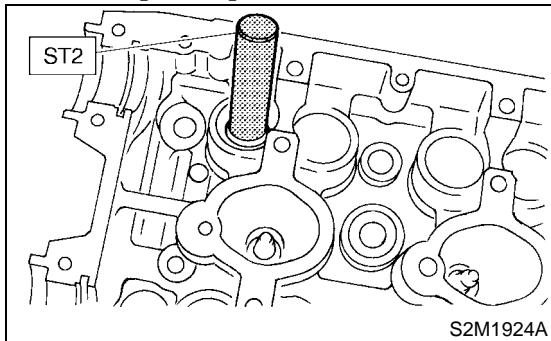

## 7. VALVE LIFTER

- 1) Check valve lifter visually.
- 2) Measure outer diameter of valve lifter.

### Outer diameter:

**34.959 — 34.975 mm (1.3763 — 1.3770 in)**

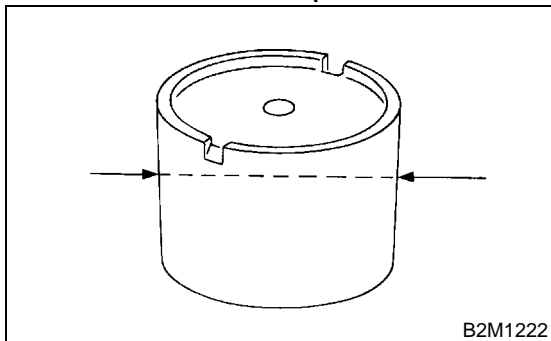

- 3) Measure inner diameter of valve lifter mating part on cylinder head.

### Inner diameter:

**34.994 — 35.016 mm (1.3777 — 1.3786 in)**

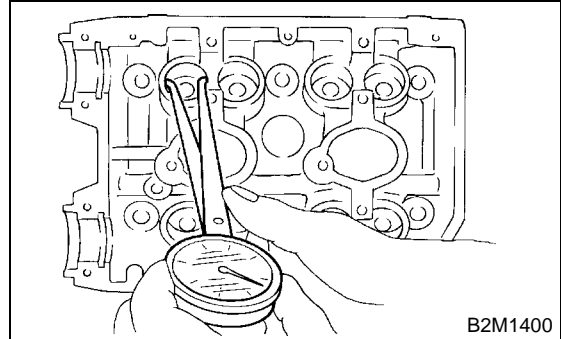

### CAUTION:

If difference between outer diameter of valve lifter and inner diameter of valve lifter mating part is over the limit, replace cylinder head.

### Standard:

**0.019 — 0.057 mm (0.0007 — 0.0022 in)**

### Limit:

**0.100 mm (0.0039 in)**

# CYLINDER BLOCK

MECHANICAL

## 20. Cylinder Block

### A: REMOVAL

#### NOTE:

Before conducting this procedure, drain engine oil completely if applicable.

- 1) Remove intake manifold. <Ref. to FU(DOHC TURBO)-15, REMOVAL, Intake Manifold.>
- 2) Remove V-belt. <Ref. to ME(DOHC TURBO)-43, REMOVAL, V-belt.>
- 3) Remove crankshaft pulley. <Ref. to ME(DOHC TURBO)-45, REMOVAL, Crankshaft Pulley.>
- 4) Remove belt cover. <Ref. to ME(DOHC TURBO)-46, REMOVAL, Belt Cover.>
- 5) Remove timing belt assembly. <Ref. to ME(DOHC TURBO)-47, REMOVAL, Timing Belt Assembly.>
- 6) Remove camshaft sprocket. <Ref. to ME(DOHC TURBO)-56, REMOVAL, Camshaft Sprocket.>
- 7) Remove crankshaft sprocket. <Ref. to ME(DOHC TURBO)-57, REMOVAL, Crankshaft Sprocket.>
- 8) Remove generator and A/C compressor with their brackets.
- 9) Remove cylinder head assembly. <Ref. to ME(DOHC TURBO)-63, REMOVAL, Cylinder Head Assembly.>
- 10) Remove clutch housing cover.
- 11) Remove flywheel.

Using ST, lock crankshaft.

ST 498497100 CRANKSHAFT STOPPER

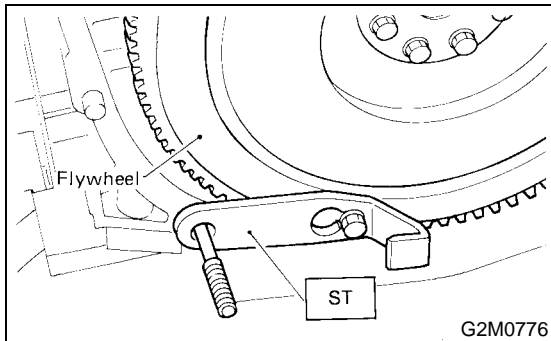

- 12) Remove oil separator cover.
- 13) Remove water by-pass pipe for heater.
- 14) Removal of oil pan
  - (1) Turn cylinder block with #2 and #4 piston sides facing upward.
  - (2) Remove bolts which secure oil pan to cylinder block.
  - (3) Insert a oil pan cutter blade between cylinder block-to-oil pan clearance and remove oil pan.

#### CAUTION:

Do not use a screwdriver or similar tool in place of oil pan cutter.

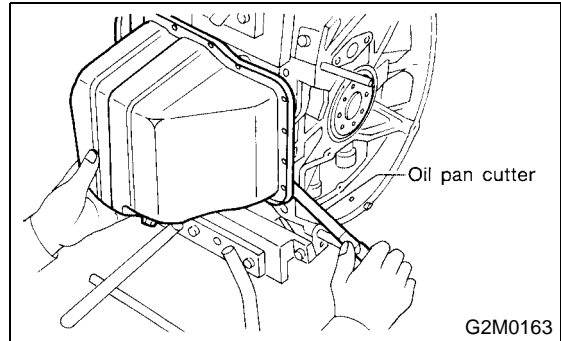

- 15) Remove oil strainer stay.
- 16) Remove oil strainer.
- 17) Remove baffle plate.
- 18) Remove water pips.
- 19) Remove water pump.
- 20) Remove oil pump from cylinder block.

Use a flat-bladed screwdriver as shown in figure when removing oil pump.

#### CAUTION:

Be careful not to scratch the mating surface of cylinder block and oil pump.

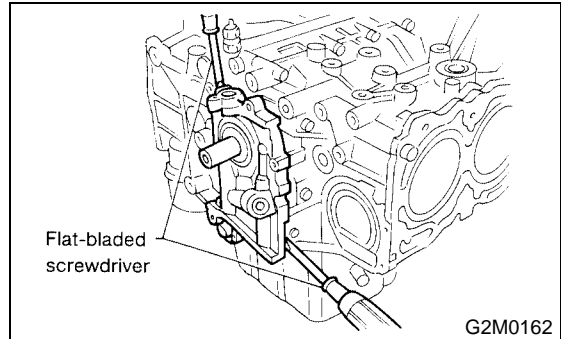

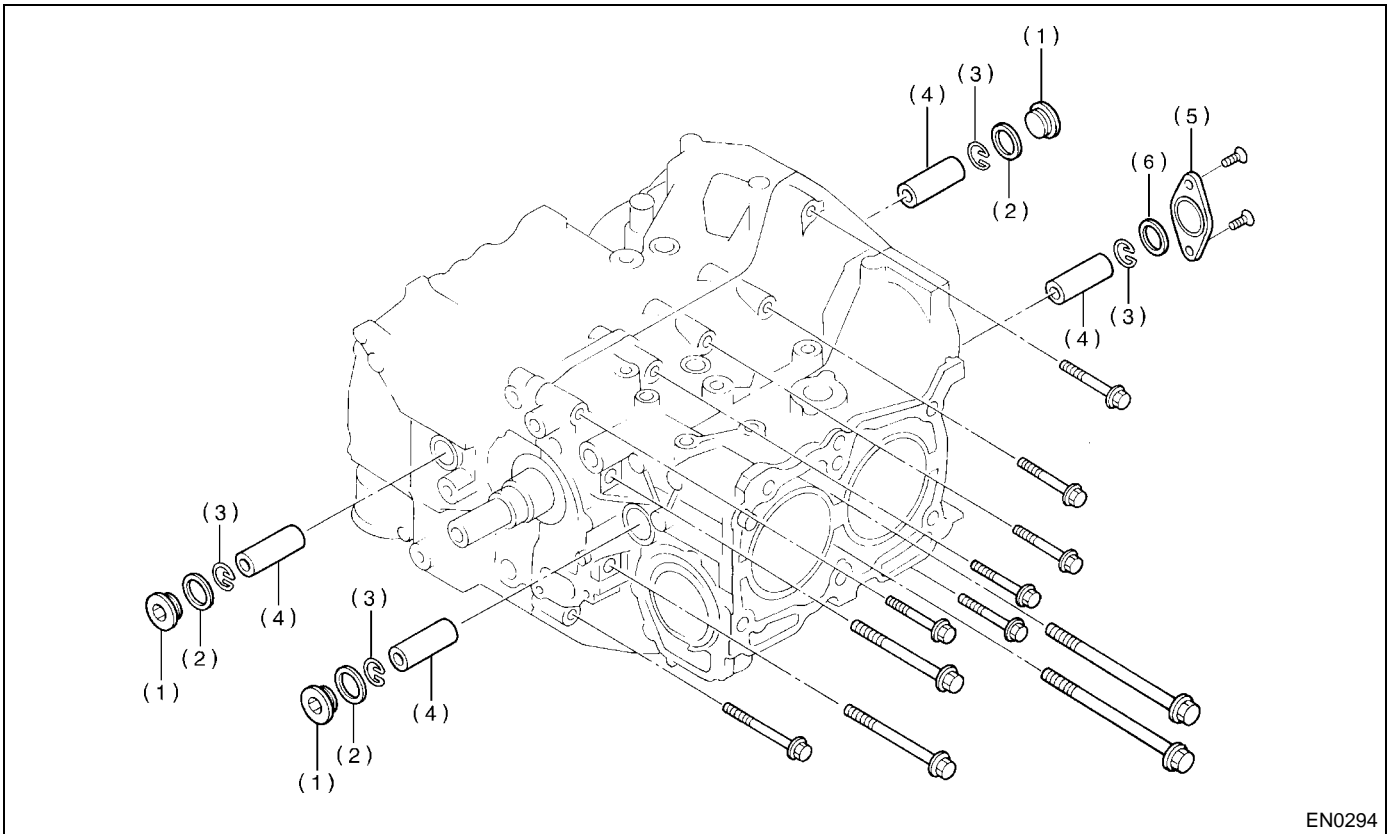

EN0294

(1) Service hole plug

(2) Gasket

(3) Circlip

(4) Piston pin

(5) Service hole cover

(6) O-ring

21) Remove service hole cover and service hole plugs using hexagon wrench [14 mm (0.55 in)].

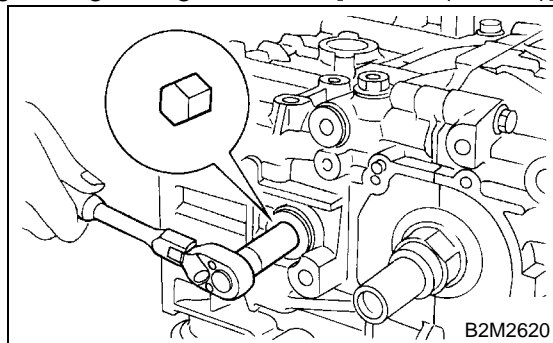

B2M2620

22) Rotate crankshaft to bring #1 and #2 pistons to bottom dead center position, then remove piston circlip through service hole of #1 and #2 cylinders.

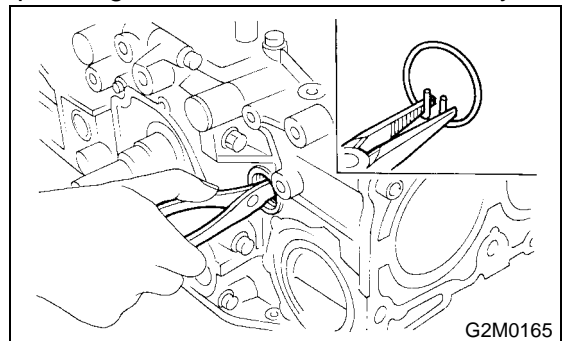

G2M0165



# CYLINDER BLOCK

## MECHANICAL

23) Draw out piston pin from #1 and #2 pistons using ST.

ST 499097700 PISTON PIN REMOVER

### CAUTION:

Be careful not to confuse original combination of piston, piston pin and cylinder.

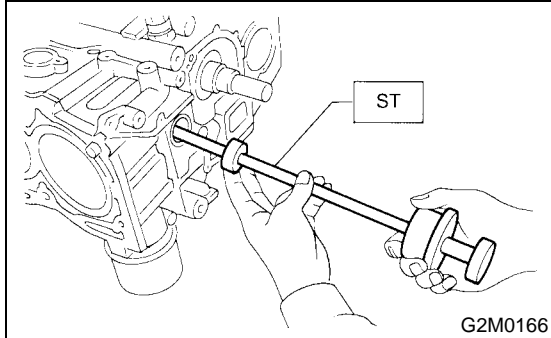

24) Similarly remove piston pins from #3 and #4 pistons.

25) Remove bolts which connect cylinder block on the side of #2 and #4 cylinders.

26) Back off bolts which connect cylinder block on the side of #1 and #3 cylinders two or three turns.

27) Set up cylinder block so that #1 and #3 cylinders are on the upper side, then remove cylinder block connecting bolts.

28) Separate left-hand and right-hand cylinder blocks.

### CAUTION:

When separating cylinder block, do not allow the connecting rod to fall and damage the cylinder block.

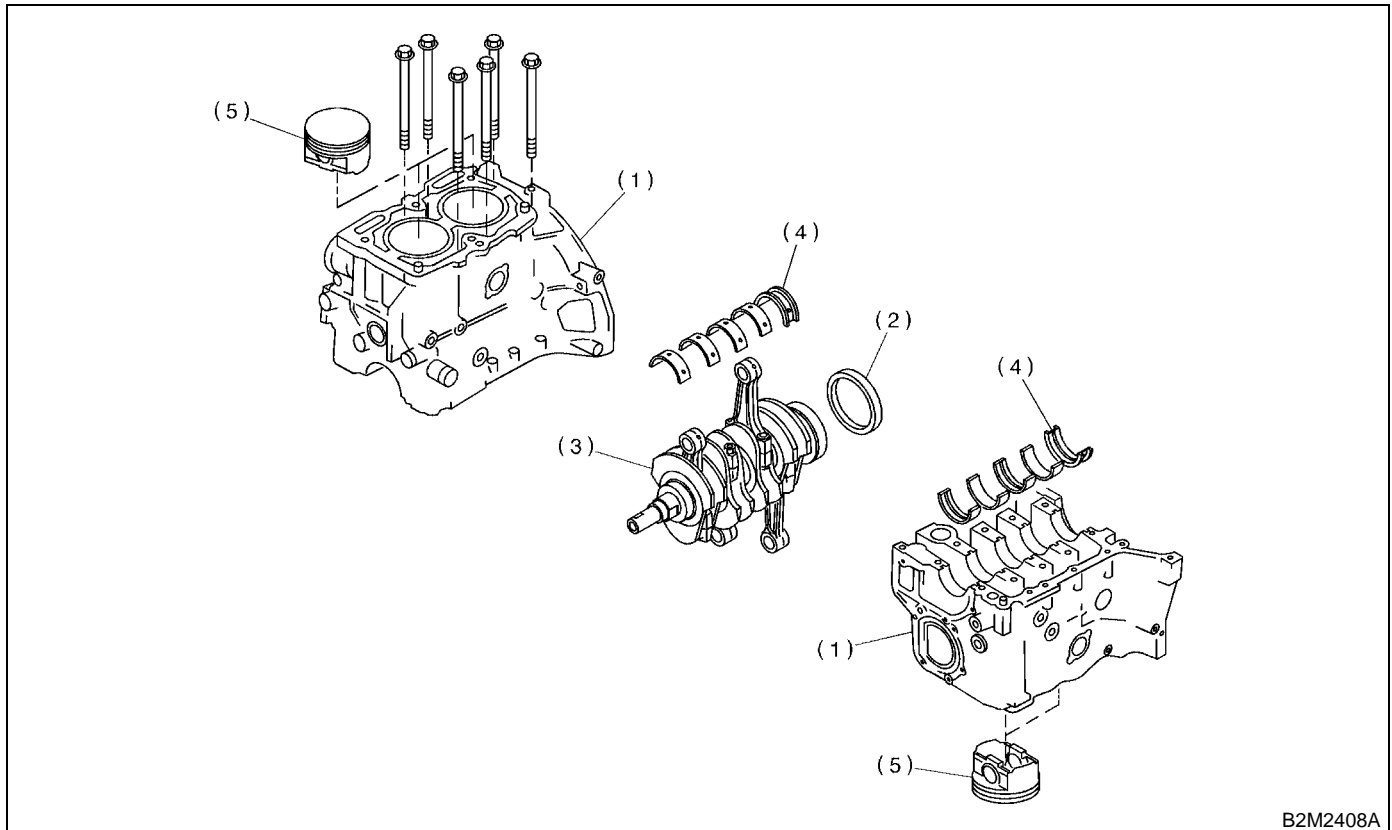

(1) Cylinder block

(2) Rear oil seal

(3) Crankshaft

(4) Crankshaft bearing

(5) Piston

29) Remove rear oil seal.

30) Remove crankshaft together with connecting rod.

31) Remove crankshaft bearings from cylinder block using hammer handle.

### CAUTION:

Do not confuse combination of crankshaft bearings. Press bearing at the end opposite to locking lip.

32) Draw out each piston from cylinder block using wooden bar or hammer handle.

### CAUTION:

Do not confuse combination of piston and cylinder.

## B: INSTALLATION

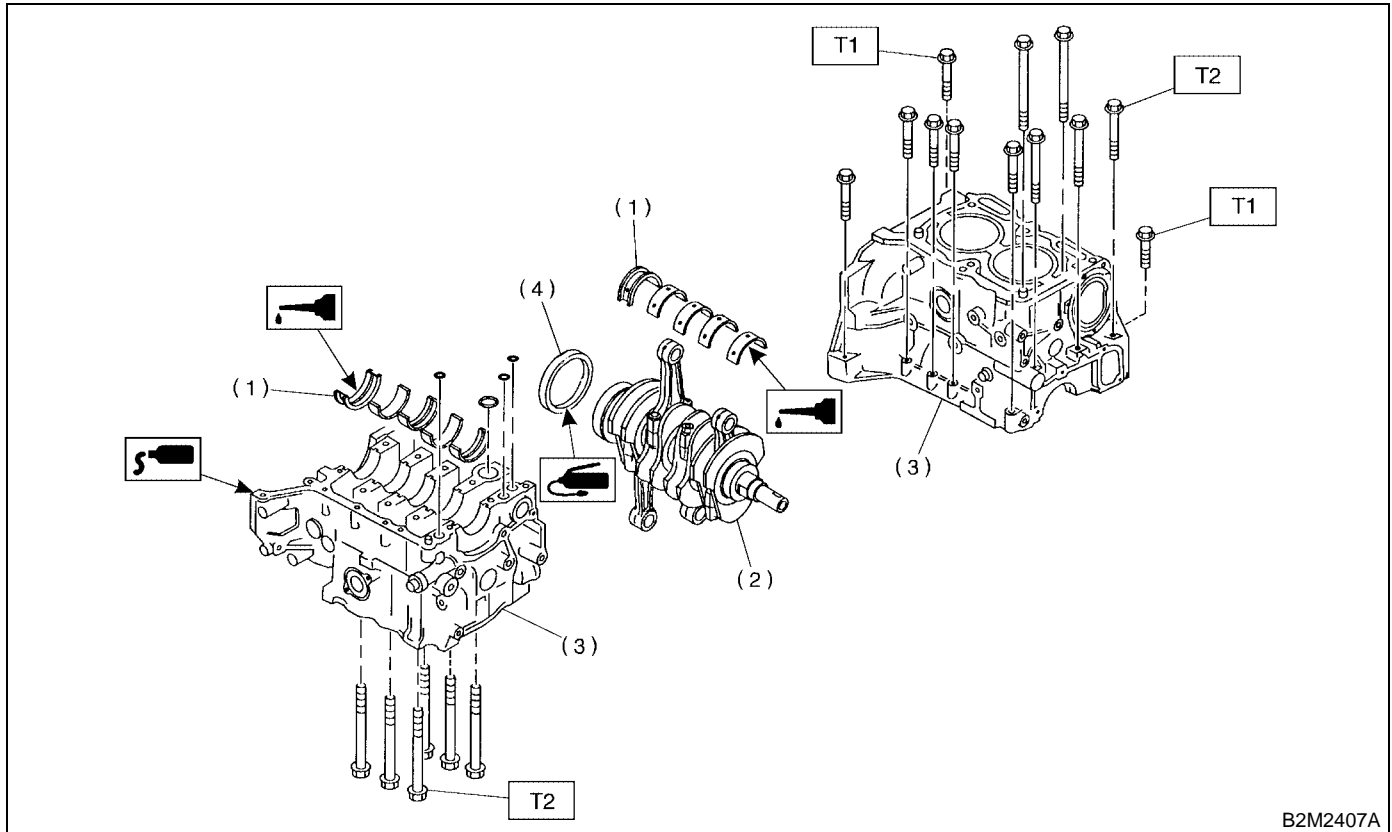

B2M2407A

- (1) Crankshaft bearing
- (2) Crankshaft
- (3) Cylinder block
- (4) Rear oil seal

**Tightening torque: N·m (kgf·m, ft·lb)**

**T1: 25 (2.5, 18.1)**

**T2: 47 (4.8, 34.7)**

**CAUTION:**

Remove oil in the mating surface of bearing and cylinder block before installation. Also apply a coat of engine oil to crankshaft pins.

1) Position crankshaft on the #2 and #4 cylinder block.

2) Apply fluid packing to the mating surface of #1 and #3 cylinder block, and position it on #2 and #4 cylinder block.

**Fluid packing:**

**THREE BOND 1215 or equivalent**

**CAUTION:**

Do not allow fluid packing to jut into O-ring grooves, oil passages, bearing grooves, etc.

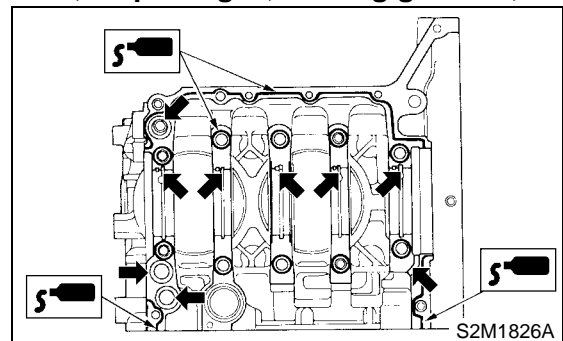

# CYLINDER BLOCK

## MECHANICAL

3) Temporarily tighten 10 mm cylinder block connecting bolts in alphabetical sequence shown in figure.

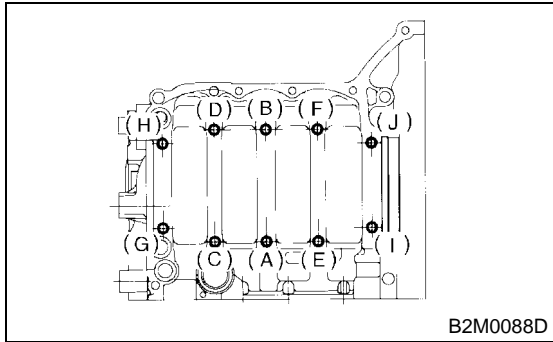

4) Tighten 10 mm cylinder block connecting bolts in alphabetical sequence.

### Tightening torque:

**$47 \pm 3 \text{ N}\cdot\text{m}$  ( $4.8 \pm 0.3 \text{ kgf}\cdot\text{m}$ ,  $34.7 \pm 2.2 \text{ ft}\cdot\text{lb}$ )**

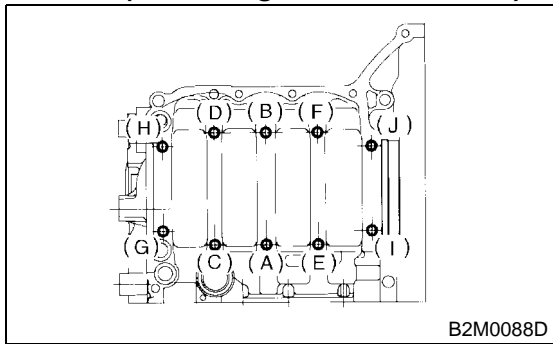

5) Tighten 8 mm and 6 mm cylinder block connecting bolts in alphabetical sequence shown in figure.

### Tightening torque:

**(A) — (G):  $25 \pm 2 \text{ N}\cdot\text{m}$  ( $2.5 \pm 0.2 \text{ kgf}\cdot\text{m}$ ,  $18.1 \pm 1.4 \text{ ft}\cdot\text{lb}$ )**

**(H):  $6.4 \text{ N}\cdot\text{m}$  ( $0.65 \text{ kgf}\cdot\text{m}$ ,  $4.7 \text{ ft}\cdot\text{lb}$ )**

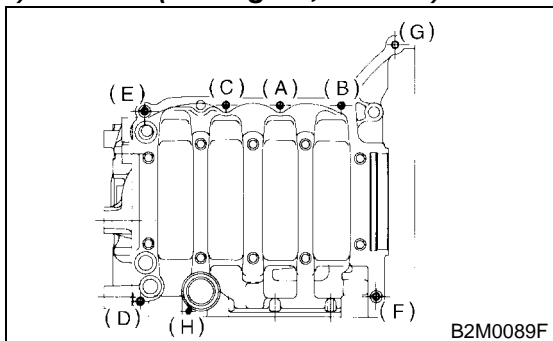

6) Install rear oil seal using ST1 and ST2.

ST1 499597100 OIL SEAL GUIDE

ST2 499587200 OIL SEAL INSTALLER

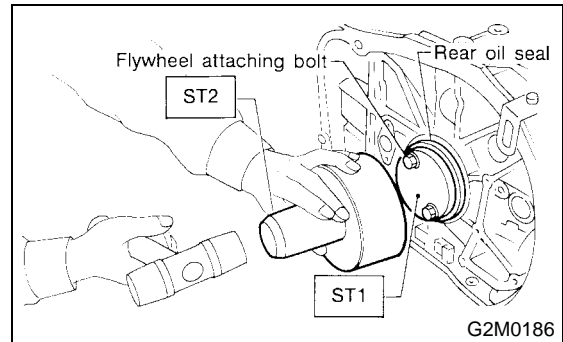

7) Position the top ring gap at (A) or (B) in the figure.

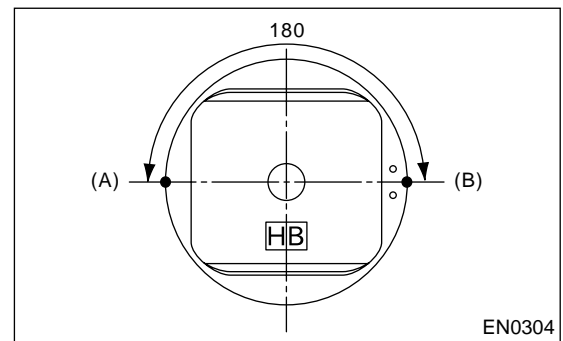

8) Position the second ring gap at 180° on the reverse side for the top ring gap.

9) Position the upper rail gap at (C) or (D) in the figure.

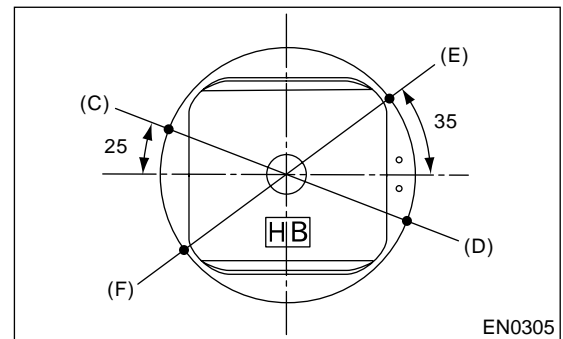

10) Position the expander gap at 180° of the reverse side for the upper rail gap.

11) Position the lower rail gap at (E) or (F) in the figure.

# CYLINDER BLOCK

MECHANICAL

**CAUTION:**

- Ensure ring gaps do not face the same direction.
- Ensure ring gaps are not within the piston skirt area.

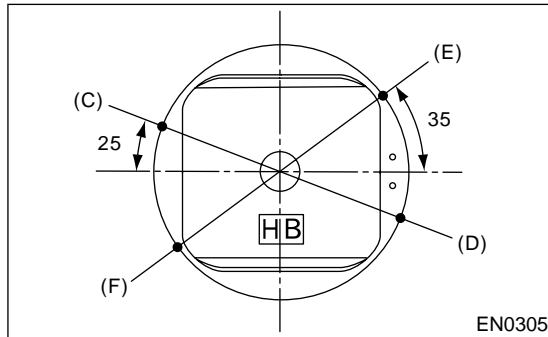

**CAUTION:**

Use new circlips.

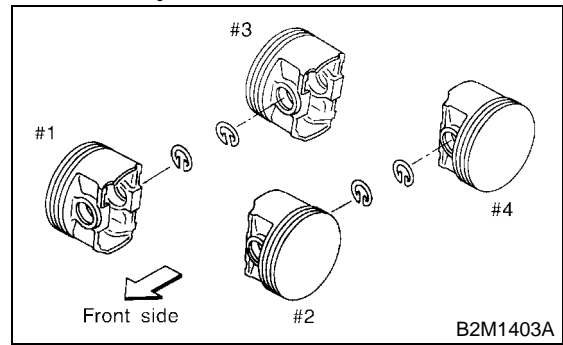

**CAUTION:**

Piston front mark faces towards the front of the engine.

12) Install circlip.

Install circlips in piston holes located opposite service holes in cylinder block, when positioning all pistons in the corresponding cylinders.

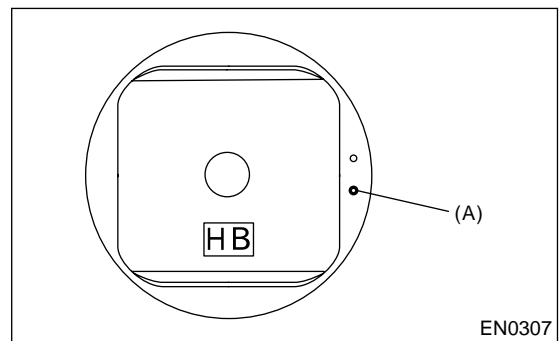

(A) Front mark

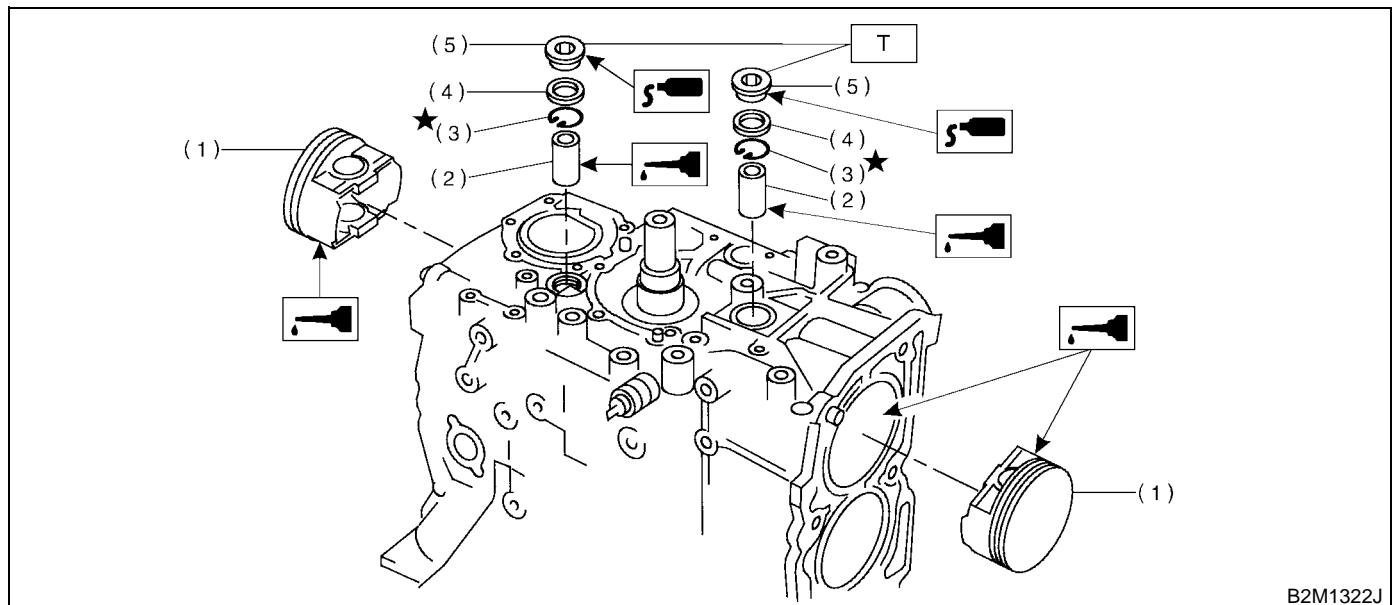

- |                |                       |
|----------------|-----------------------|
| (1) Piston     | (4) Gasket            |
| (2) Piston pin | (5) Service hole plug |
| (3) Circlip    |                       |

**Tightening torque: N·m (kgf-m, ft-lb)**  
**T: 69 (7.0, 50.6)**

# CYLINDER BLOCK

## MECHANICAL

### 13) Installing piston

- (1) Turn cylinder block so that #1 and #2 cylinders face upward.
- (2) Using ST1, turn crankshaft so that #1 and #2 connecting rods are set at bottom dead center.

ST1 499987500 CRANKSHAFT SOCKET

- (3) Apply a coat of engine oil to pistons and cylinders and insert pistons in their cylinders using ST2.

ST2 498744300 PISTON GUIDE

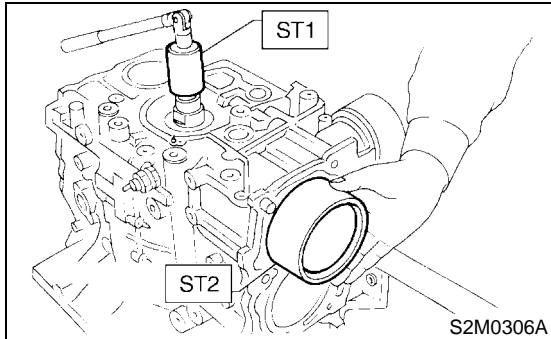

### 14) Installing piston pin

- (1) Insert ST3 into service hole to align piston pin hole with connecting rod small end.

#### CAUTION:

Apply a coat of engine oil to ST3 before insertion.

ST3 499017100 PISTON PIN GUIDE

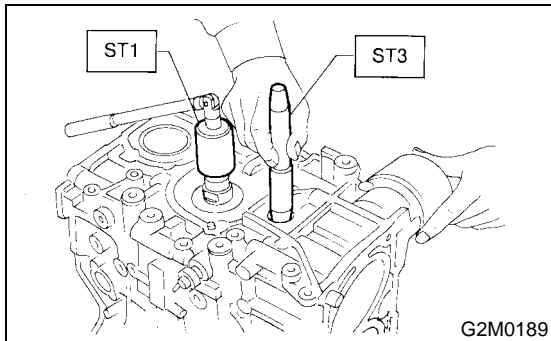

- (2) Apply a coat of engine oil to piston pin and insert piston pin into piston and connecting rod through service hole.
- (3) Install circlip.

#### CAUTION:

Use new circlips.

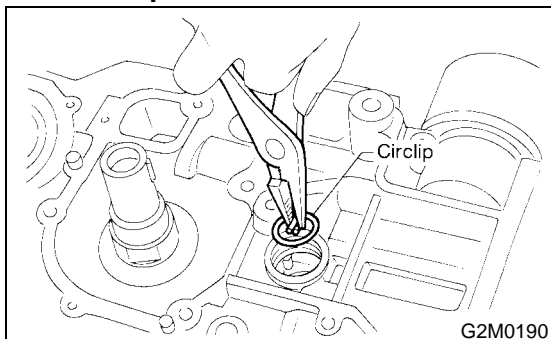

- (4) Apply fluid packing around the service hole plug.

#### Fluid packing:

**THREE BOND 1215 or equivalent**

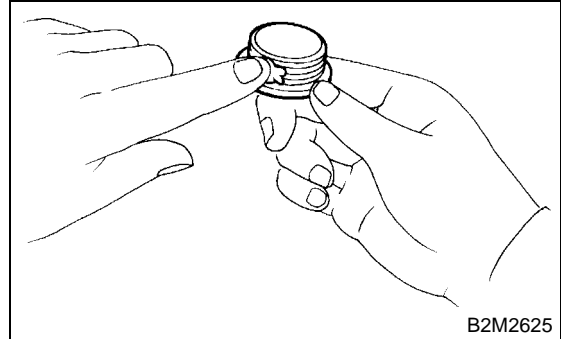

- (5) Install service hole plug and gasket.

#### CAUTION:

Use a new gasket.

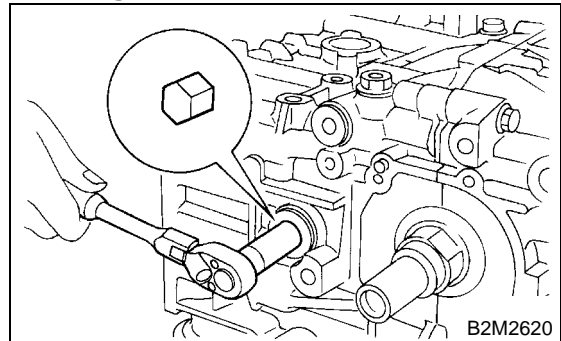

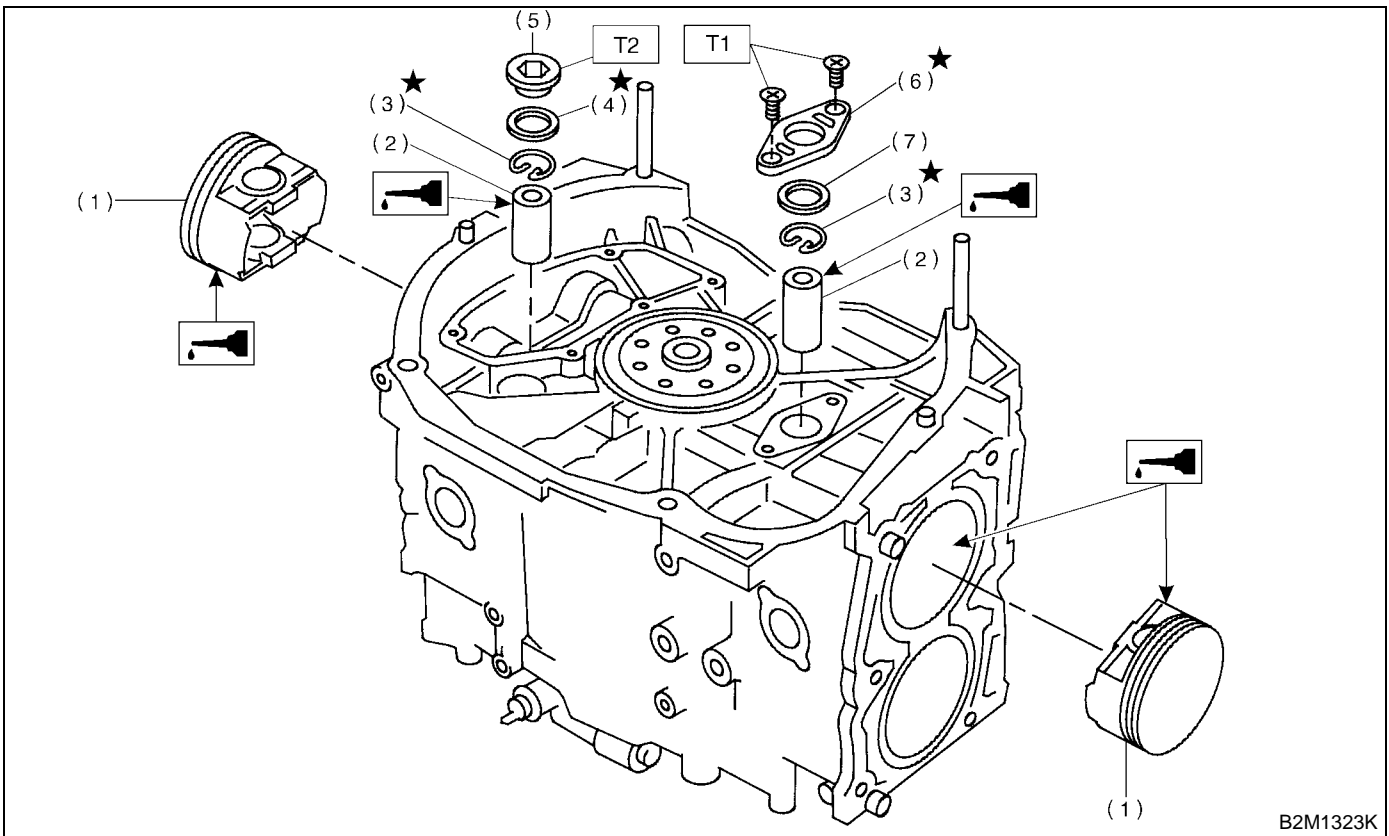

B2M1323K

- |                |                        |
|----------------|------------------------|
| (1) Piston     | (5) Service hole plug  |
| (2) Piston pin | (6) Service hole cover |
| (3) Circlip    | (7) O-ring             |
| (4) Gasket     |                        |

**Tightening torque: N·m (kgf·m, ft·lb)**

**T1: 6.4 (0.65, 4.7)**

**T2: 69 (7.0, 50.6)**

(6) Turn cylinder block so that #3 and #4 cylinders face upward. Using the same procedures as used for #1 and #2 cylinders, install pistons and piston pins.

- 15) Install water pipe.
- 16) Install baffle plate.

**Tightening torque:**  
**6.4 N·m (0.65 kgf·m, 4.7 ft·lb)**

- 17) Install oil strainer and O-ring

**Tightening torque:**  
**10 N·m (1.0 kgf·m, 7 ft·lb)**

- 18) Install oil strainer stay.

- 19) Apply fluid packing to matching surfaces and install oil pan.

**Fluid packing:**  
**THREE BOND 1215 or equivalent**

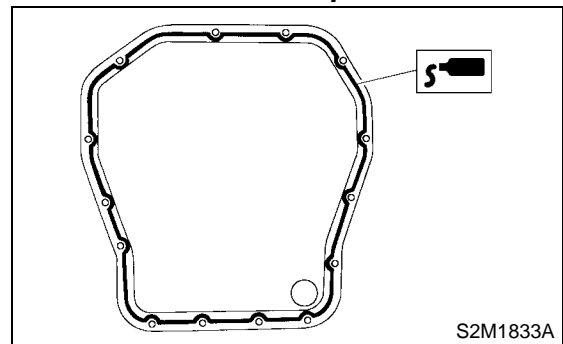

S2M1833A

# CYLINDER BLOCK

## MECHANICAL

20) Apply fluid packing to matching surfaces and install oil separator cover.

### Fluid packing:

**THREE BOND 1215 or equivalent**

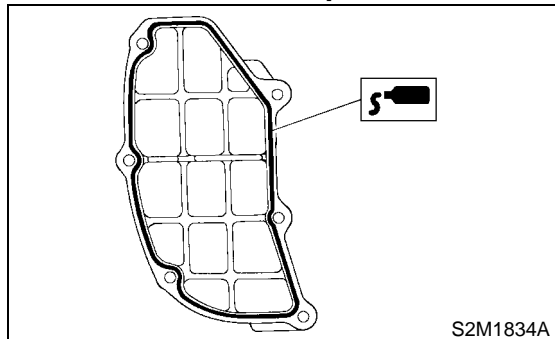

21) Install flywheel.

To lock crankshaft, use ST.

ST 498497100 CRANKSHAFT STOPPER

### Tightening torque:

**72 N·m (7.3 kgf·m, 52.8 ft·lb)**

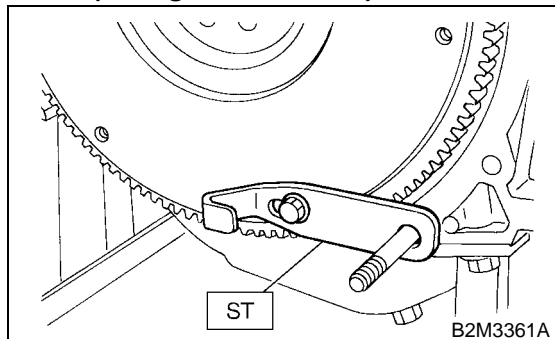

22) Install housing cover.

23) Installation of oil pump

(1) Discard front oil seal after removal. Replace with a new one using ST.

ST 499587100 OIL SEAL INSTALLER

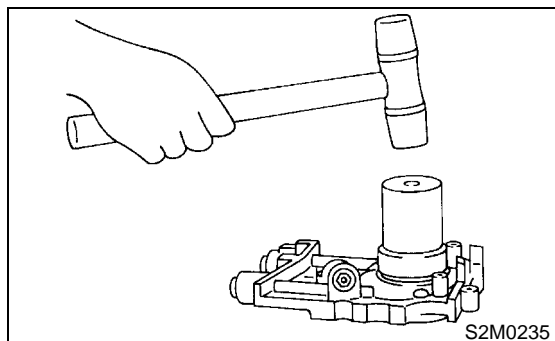

(2) Apply fluid packing to matching surface of oil pump.

### Fluid packing:

**THREE BOND 1215 or equivalent**

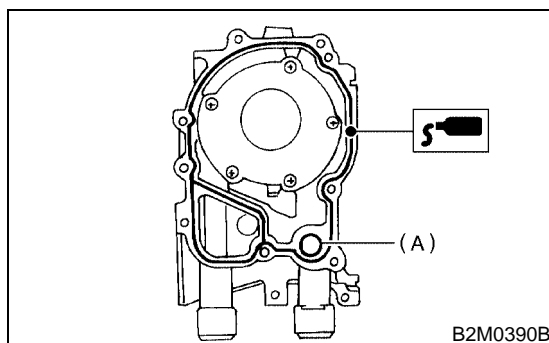

(A) O-ring

(3) Apply a coat of engine oil to the inside of the oil seal.

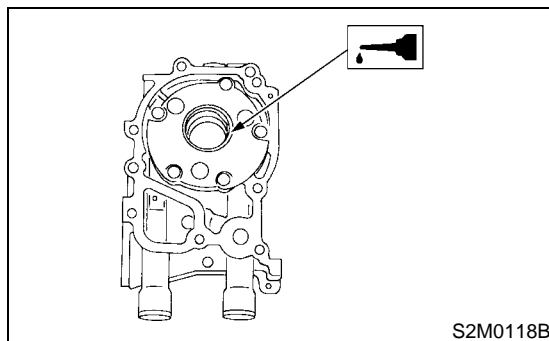

(4) Install oil pump on cylinder block. Be careful not to damage oil seal during installation.

### Tightening torque:

**6.4 N·m (0.65 kgf·m, 4.7 ft·lb)**

### CAUTION:

- Do not forget to install O-ring and seal when installing oil pump.
- Align flat surface of oil pump's inner rotor with crankshaft before installation.

24) Install water pump and gasket.

### Tightening torque:

**First; 12 N·m (1.2 kgf·m, 8.7 ft·lb)**

**Second; 12 N·m (1.2 kgf·m, 8.7 ft·lb)**

### CAUTION:

- Be sure to use a new gasket.
- When installing water pump, tighten bolts in two stages in alphabetical sequence as shown in figure.

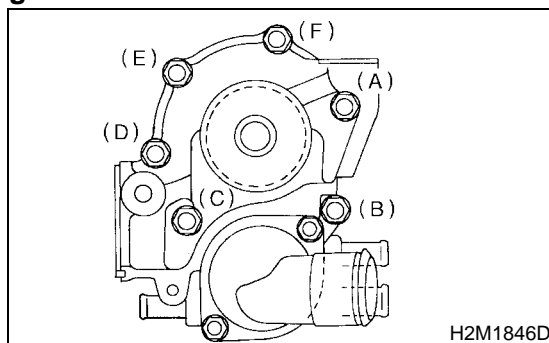

- 25) Install water by-pass pipe for heater.
- 26) Install oil cooler.

**Tightening torque:**

**T1: 55 N·m (5.5 kgf·m, 40 ft·lb)**

**T2: 69 N·m (7.0 kgf·m, 50.6 ft·lb)**

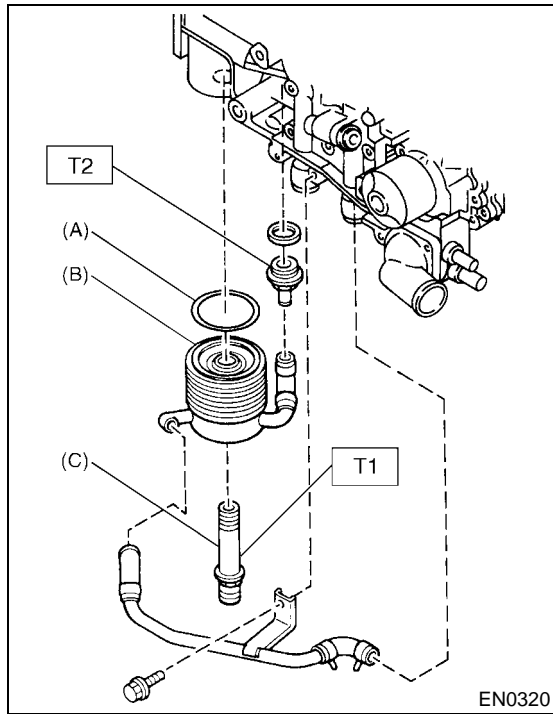

- (A) O-ring
- (B) Oil cooler
- (C) Connector

- 27) Install oil filter using ST.  
ST 498547000 OIL FILTER WRENCH
- 28) Install water by-pass pipe between oil cooler and water pump.

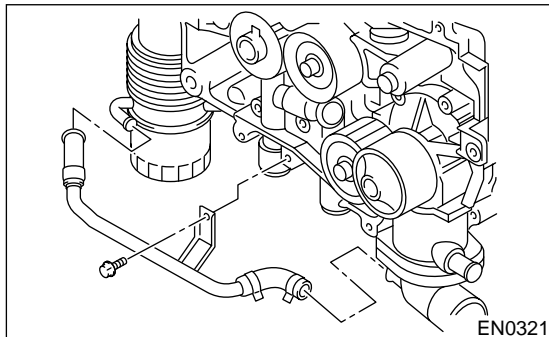

- 29) Install water pipe.

**CAUTION:**

**Always use a new O-ring.**

- 30) Install cylinder head assembly. <Ref. to ME(DOHC TURBO)-63, INSTALLATION, Cylinder Head Assembly.>
- 31) Install oil level gauge guide and tighten attaching bolt (left side only).
- 32) Install rocker cover.

- 33) Install crankshaft sprocket. <Ref. to ME(DOHC TURBO)-57, INSTALLATION, Crankshaft Sprocket.>
- 34) Install camshaft sprocket. <Ref. to ME(DOHC TURBO)-56, INSTALLATION, Camshaft Sprocket.>
- 35) Install timing belt assembly. <Ref. to ME(DOHC TURBO)-48, INSTALLATION, Timing Belt Assembly.>
- 36) Install belt cover. <Ref. to ME(DOHC TURBO)-46, INSTALLATION, Belt Cover.>
- 37) Install crankshaft pulley. <Ref. to ME(DOHC TURBO)-45, INSTALLATION, Crankshaft Pulley.>
- 38) Install generator and A/C compressor brackets on cylinder head.
- 39) Install V-belt. <Ref. to ME(DOHC TURBO)-43, INSTALLATION, V-belt.>
- 40) Install intake manifold. <Ref. to FU(DOHC TURBO)-15, REMOVAL, Intake Manifold.>



# CYLINDER BLOCK

MECHANICAL

## C: DISASSEMBLY

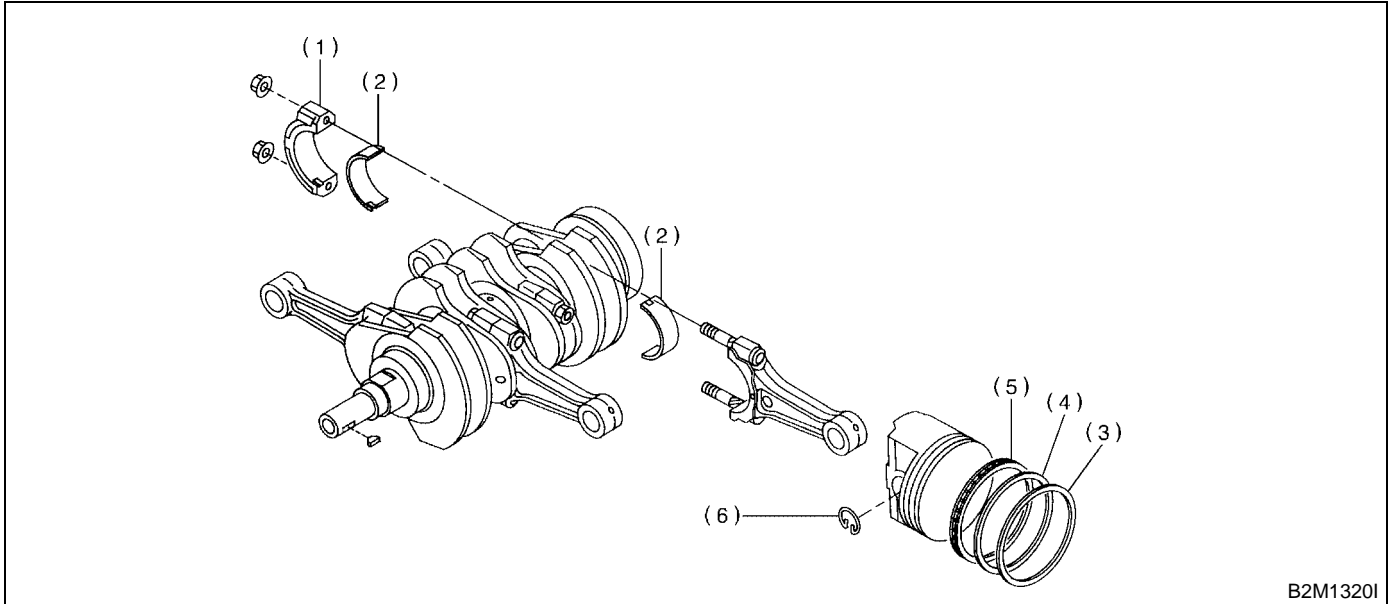

B2M1320I

- |                            |                 |              |
|----------------------------|-----------------|--------------|
| (1) Connecting rod cap     | (3) Top ring    | (5) Oil ring |
| (2) Connecting rod bearing | (4) Second ring | (6) Circlip  |

- 1) Remove connecting rod cap.
- 2) Remove connecting rod bearing.

### CAUTION:

**Arrange removed connecting rod, connecting rod cap and bearing in order to prevent confusion.**

- 3) Remove piston rings using the piston ring expander.
- 4) Remove the oil ring by hand.

### CAUTION:

**Arrange the removed piston rings in good order to prevent confusion.**

- 5) Remove circlip.

## D: ASSEMBLY

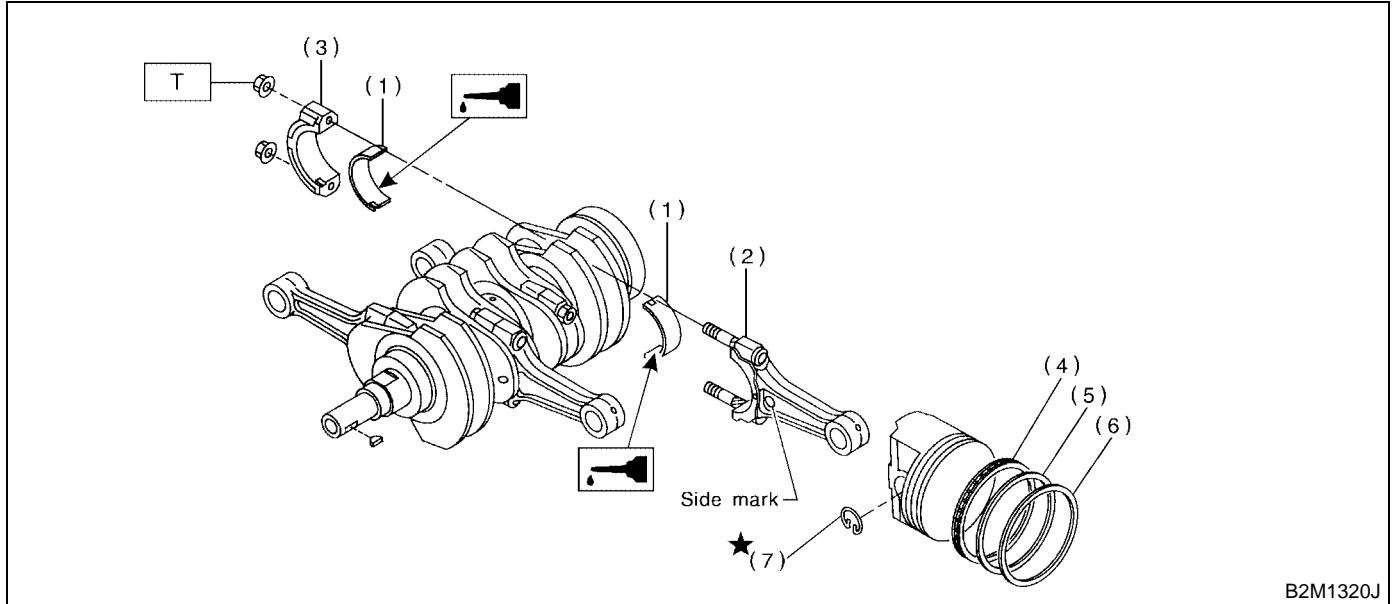

- |                            |                 |
|----------------------------|-----------------|
| (1) Connecting rod bearing | (5) Second ring |
| (2) Connecting rod         | (6) Top ring    |
| (3) Connecting rod cap     | (7) Circlip     |
| (4) Oil ring               |                 |

**Tightening torque: N·m (kgf·m, ft·lb)**  
**T: 44.6 (4.55, 32.9)**

1) Install connecting rod bearings on connecting rods and connecting rod caps.

**CAUTION:**

**Apply oil to the surfaces of the connecting rod bearings.**

2) Install connecting rod on crankshaft.

**CAUTION:**

**Position each connecting rod with the side marked facing forward.**

3) Install connecting rod cap with connecting rod nut.

Ensure the arrow on connecting rod cap faces the front during installation.

**CAUTION:**

- Each connecting rod has its own mating cap. Make sure that they are assembled correctly by checking their matching number.

- When tightening the connecting rod nuts, apply oil on the threads.

4) Install oil ring spacer, upper rail and lower rail in this order by hand. Then install second ring and top ring with a piston ring expander.

## E: INSPECTION

### 1. CYLINDER BLOCK

1) Visually check for cracks and damage. Especially, inspect important parts by means of red lead check.

2) Check the oil passages for clogging.

3) Inspect crankcase surface that mates with cylinder head for warping by using a straight edge, and correct by grinding if necessary.

**Warping limit:**

**0.05 mm (0.0020 in)**

**Grinding limit:**

**0.1 mm (0.004 in)**

**Standard height of cylinder block:**

**201.0 mm (7.91 in)**

# CYLINDER BLOCK

MECHANICAL

## 2. CYLINDER AND PISTON

1) The cylinder bore size is stamped on the cylinder block's front upper surface.

**CAUTION:**

Measurement should be performed at a temperature 20°C (68°F).

**NOTE:**

Standard sized pistons are classified into two grades, "A" and "B". These grades should be used as a guide line in selecting a standard piston.

**Standard diameter:**

**A: 92.005 — 92.015 mm (3.6222 — 3.6226 in)**

**B: 91.995 — 92.005 mm (3.6218 — 3.6222 in)**

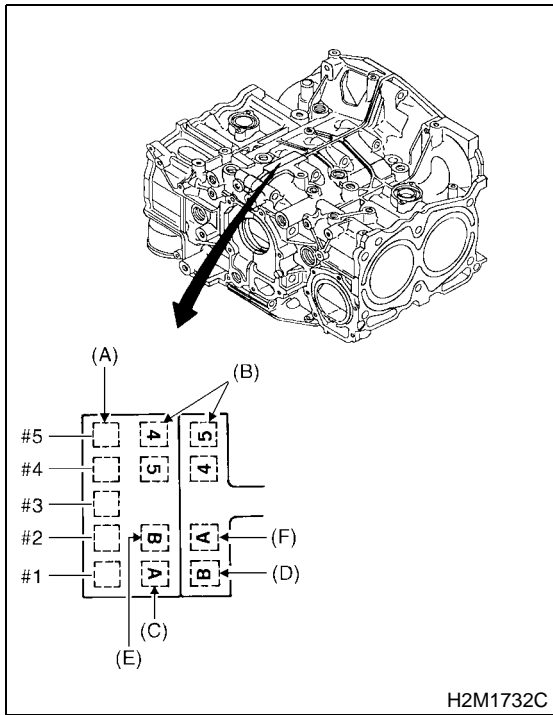

- (A) Main journal size mark
- (B) Cylinder block RH-LH combination mark
- (C) #1 cylinder bore size mark
- (D) #2 cylinder bore size mark
- (E) #3 cylinder bore size mark
- (F) #4 cylinder bore size mark

2) How to measure the inner diameter of each cylinder

Measure the inner diameter of each cylinder in both the thrust and piston pin directions at the heights shown in the figure, using a cylinder bore gauge.

**CAUTION:**

Measurement should be performed at a temperature 20°C (68°F).

**Taper:**

**Standard**

0.015 mm (0.0006 in)

**Limit**

0.050 mm (0.0020 in)

**Out-of-roundness:**

**Standard**

0.010 mm (0.0004 in)

**Limit**

0.050 mm (0.0020 in)

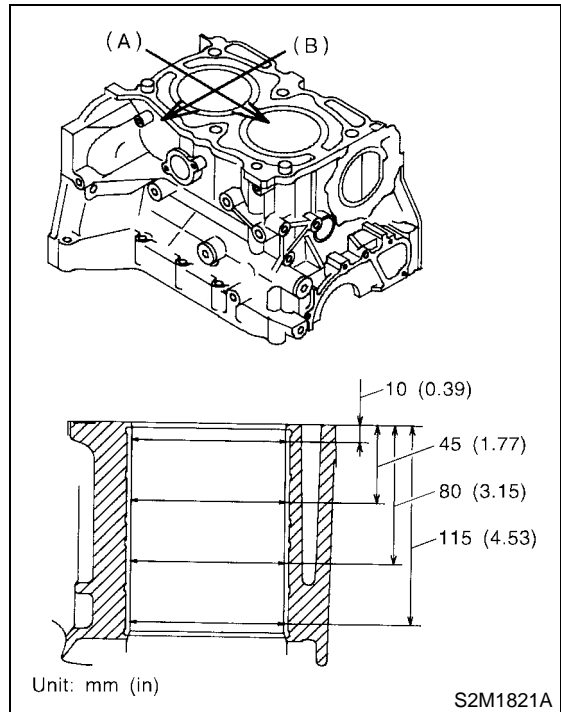

- (A) Thrust direction
- (B) Piston pin direction

3) When piston is to be replaced due to general or cylinder wear, determine a suitable sized piston by measuring the piston clearance.

4) How to measure the outer diameter of each piston

Measure the outer diameter of each piston at the height shown in the figure. (Thrust direction)

**CAUTION:**

Measurement should be performed at a temperature of 20°C (68°F).

**Piston grade point H:**  
 37.0 mm (1.457 in)

**Piston outer diameter:**  
**Standard**

**A:** 91.985 — 91.995 mm  
 (3.6214 — 3.6218 in)

**B:** 91.975 — 91.985 mm  
 (3.6211 — 3.6214 in)

**0.25 mm (0.0098 in) oversize**  
 92.225 — 92.235 mm  
 (3.6309 — 3.6313 in)

**0.50 mm (0.0197 in) oversize**  
 92.475 — 92.485 mm  
 (3.6407 — 3.6411 in)

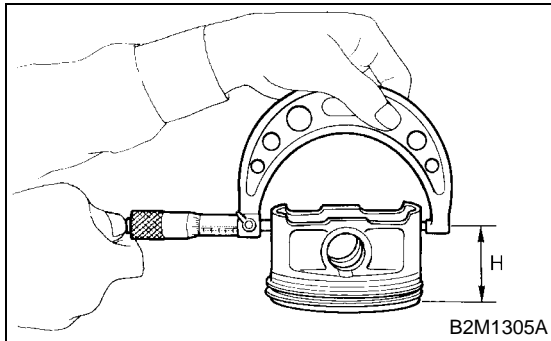

5) Calculate the clearance between cylinder and piston.

**CAUTION:**

Measurement should be performed at a temperature of 20°C (68°F).

**Cylinder to piston clearance at 20°C (68°F):**

**Standard**  
 0.010 — 0.030 mm (0.0004 — 0.0012 in)

**Limit**  
 0.050 mm (0.0020 in)

6) Boring and honing

(1) If the value of taper, out-of-roundness, or cylinder-to-piston clearance measured exceeds the specified limit or if there is any damage on the cylinder wall, rebores it to use an oversize piston.

**CAUTION:**

When any of the cylinders needs reboring, all other cylinders must be bored at the same time, and use oversize pistons. Do not perform boring on one cylinder only, nor use an oversize piston for one cylinder only.

(2) If the cylinder inner diameter exceeds the limit after boring and honing, replace the crankcase.

**CAUTION:**

Immediately after reboring, the cylinder diameter may differ from its real diameter due to tem-

perature rise. Thus, pay attention to this when measuring the cylinder diameter.

**Limit of cylinder enlarging (boring):**  
 0.5 mm (0.020 in)

### 3. PISTON AND PISTON PIN

1) Check pistons and piston pins for damage, cracks, and wear and the piston ring grooves for wear and damage. Replace if defective.

2) Measure the piston-to-cylinder clearance at each cylinder. <Ref. to ME(DOHC TURBO)-82, CYLINDER AND PISTON, INSPECTION, Cylinder Block.> If any of the clearances is not to specification, replace the piston or bore the cylinder to use an oversize piston.

3) Make sure that piston pin can be inserted into the piston pin hole with a thumb at 20°C (68°F). Replace if defective.

**Standard clearance between piston pin and hole in piston:**

**Standard**  
 0.004 — 0.008 mm (0.0002 — 0.0003 in)

**Limit**  
 0.020 mm (0.0008 in)

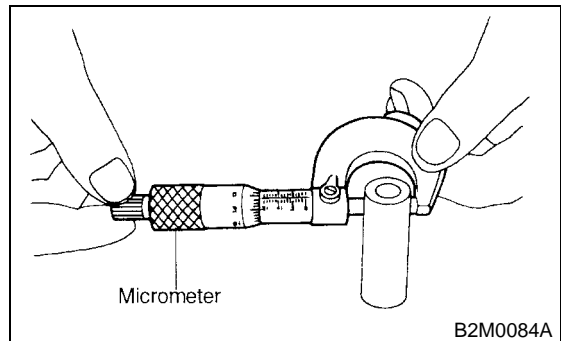
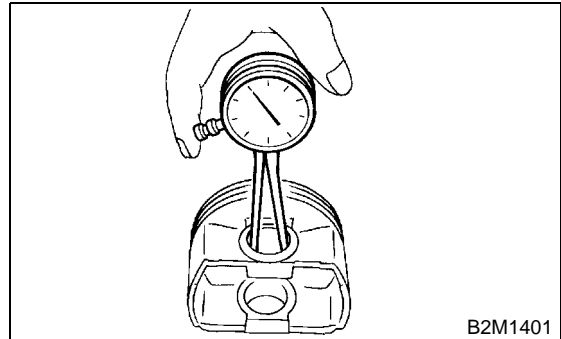

# CYLINDER BLOCK

## MECHANICAL

4) Check circlip installation groove on the piston for burr (A). If necessary, remove burr from the groove so that piston pin can lightly move.

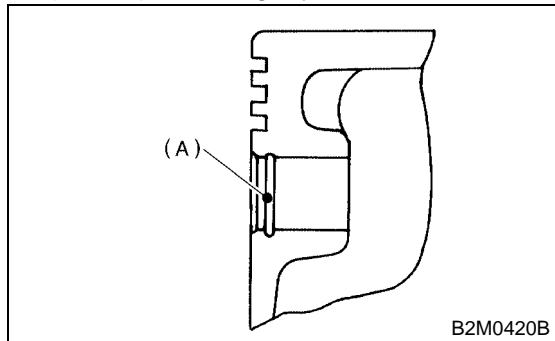

5) Check piston pin circlip for distortion, cracks and wear.

## 4. PISTON RING

1) If piston ring is broken, damaged, or worn, or if its tension is insufficient, or when the piston is replaced, replace piston ring with a new one of the same size as the piston.

### CAUTION:

• "N" is marked on the end of the top and second rings. When installing the rings to the piston, face this mark upward.

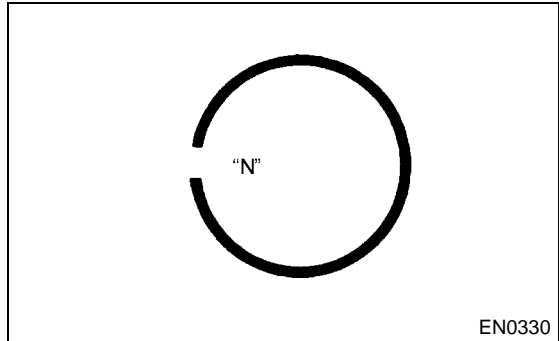

• The oil ring is a combined ring consisting of two rails and a spacer in between. When installing, be careful to assemble correctly.

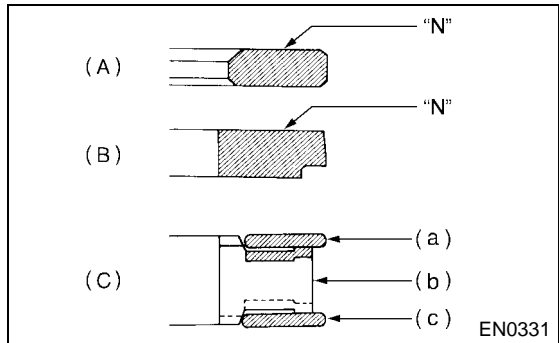

- (A) Top ring
- (B) Second ring
- (C) Oil ring
- (D) Upper rail
- (E) Spacer
- (F) Lower rail

2) Squarely place piston ring and oil ring in cylinder, and measure the piston ring gap with a thickness gauge.

|                 |               | Unit: mm (in)                    |             |
|-----------------|---------------|----------------------------------|-------------|
|                 |               | Standard                         | Limit       |
| Piston ring gap | Top ring      | 0.20 — 0.35<br>(0.0079 — 0.0138) | 1.0 (0.039) |
|                 | Second ring   | 0.35 — 0.50<br>(0.0138 — 0.0197) | 1.0 (0.039) |
|                 | Oil ring rail | 0.20 — 0.70<br>(0.0079 — 0.0276) | 1.5 (0.059) |

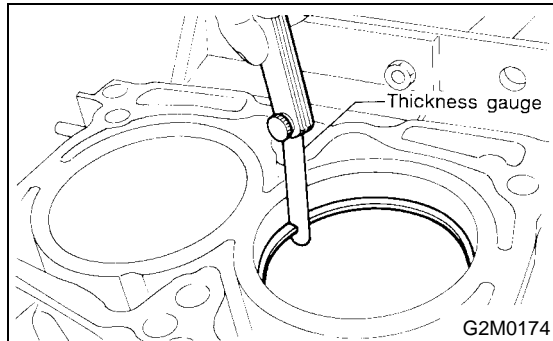

3) Measure the clearance between piston ring and piston ring groove with a thickness gauge.

**CAUTION:**  
Before measuring the clearance, clean the piston ring groove and piston ring.

|  |             | Unit: mm (in)                      |               |
|--|-------------|------------------------------------|---------------|
|  |             | Standard                           | Limit         |
| Clearance between piston ring and piston ring groove | Top ring    | 0.040 — 0.080<br>(0.0016 — 0.0031) | 0.15 (0.0059) |
|  | Second ring | 0.030 — 0.070<br>(0.0012 — 0.0028) | 0.15 (0.0059) |

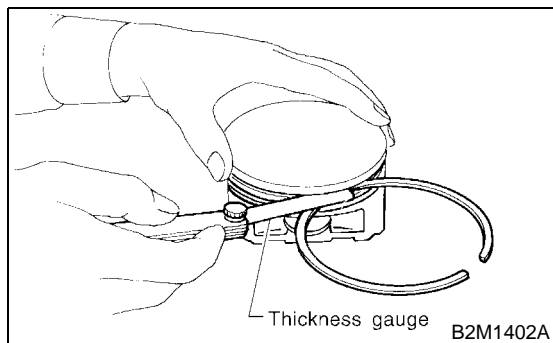

## 5. CONNECTING ROD

- 1) Replace connecting rod, if the large or small end thrust surface is damaged.
- 2) Check for bend or twist using a connecting rod aligner. Replace connecting rod if the bend or twist exceeds the limit.

**Limit of bend or twist per 100 mm (3.94 in) in length:**  
**0.10 mm (0.0039 in)**

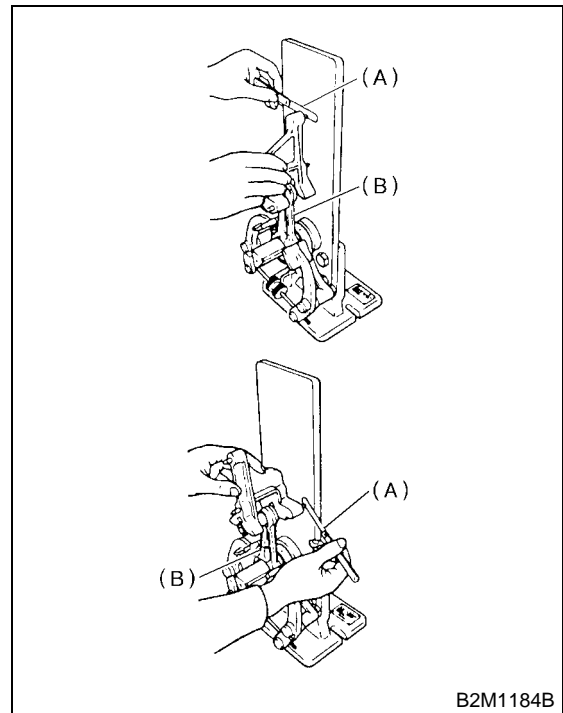

- (A) Thickness gauge  
(B) Connecting rod

3) Install connecting rod fitted with bearing to crankshaft and measure the side clearance (thrust clearance). Replace connecting rod if the side clearance exceeds the specified limit.

**Connecting rod side clearance:**

**Standard**

**0.070 — 0.330 mm (0.0028 — 0.0130 in)**

**Limit**

**0.4 mm (0.016 in)**

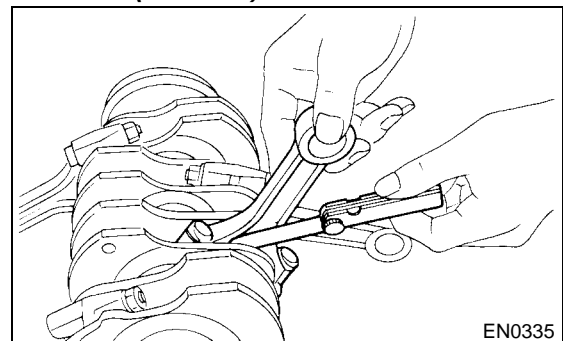

# CYLINDER BLOCK

## MECHANICAL

4) Inspect connecting rod bearing for scar, peeling, seizure, melting, wear, etc.

5) Measure the oil clearance on individual connecting rod bearings by means of plastigauge. If any oil clearance is not within specification, replace the defective bearing with a new one of standard size or undersize as necessary. (See the table below.)

### Connecting rod oil clearance:

#### Standard

0.020 — 0.046 mm (0.0008 — 0.0018 in)

#### Limit

0.05 mm (0.0020 in)

| Unit: mm (in)                 |                                       |                                      |
|-------------------------------|---------------------------------------|--------------------------------------|
| Bearing                       | Bearing size<br>(Thickness at center) | Outer diameter of<br>crank pin       |
| Standard                      | 1.492 — 1.501<br>(0.0587 — 0.0591)    | 47.984 — 48.000<br>(4.8891 — 1.8898) |
| 0.03<br>(0.0012)<br>undersize | 1.510 — 1.513<br>(0.0594 — 0.0596)    | 47.954 — 47.970<br>(1.8879 — 1.8886) |
| 0.05<br>(0.0020)<br>undersize | 1.520 — 1.523<br>(0.0598 — 0.0600)    | 47.934 — 47.950<br>(1.8872 — 1.8878) |
| 0.25<br>(0.0098)<br>undersize | 1.620 — 1.623<br>(0.0638 — 0.0639)    | 47.734 — 47.750<br>(1.8793 — 1.8799) |

6) Inspect bushing at connecting rod small end, and replace if worn or damaged. Also measure the piston pin clearance at the connecting rod small end.

### Clearance between piston pin and bushing:

#### Standard

0 — 0.022 mm (0 — 0.0009 in)

#### Limit

0.030 mm (0.0012 in)

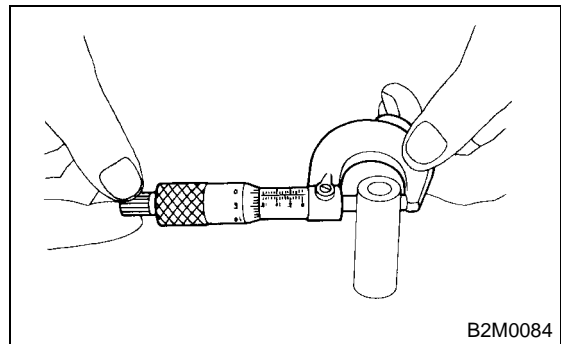
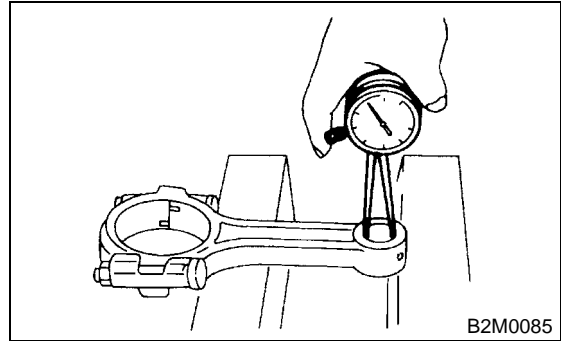

7) Replacement procedure is as follows.

- (1) Remove bushing from connecting rod with ST and press.
- (2) Press bushing with ST after applying oil on the periphery of bushing.

ST 499037100 CONNECTING ROD BUSHING REMOVER AND INSTALLER

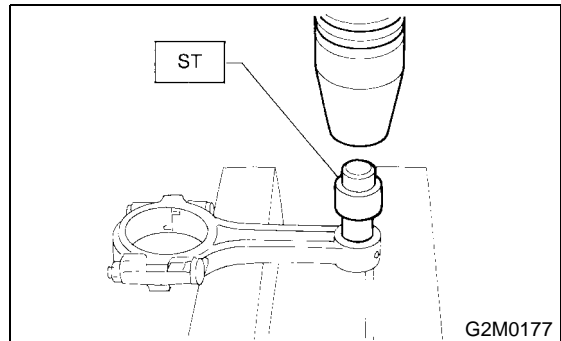

(3) Make two 3 mm (0.12 in) holes in bushing. Ream the inside of bushing.

(4) After completion of reaming, clean bushing to remove chips.

## 6. CRANKSHAFT AND CRANKSHAFT BEARING

- 1) Clean crankshaft completely and check for cracks by means of red lead check etc., and replace if defective.
- 2) Measure the crankshaft bend, and correct or replace if it exceeds the limit.

### CAUTION:

If a suitable V-block is not available, install #1 and #5 crankshaft bearing on cylinder block, position crankshaft on these bearings and measure crankshaft bend using a dial gauge.

**Crankshaft bend limit:**  
**0.035 mm (0.0014 in)**

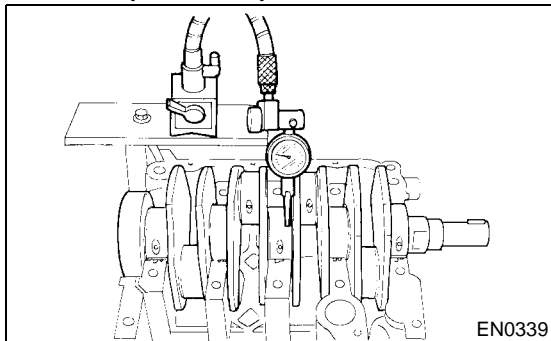

- 3) Inspect the crank journal and crank pin for wear. If they are not within the specifications, replace bearing with a suitable (undersize) one, and replace or recondition crankshaft as necessary. When grinding crank journal or crank pin, finish them to the specified dimensions according to the undersize bearing to be used.

### **Crank pin and crank journal:**

#### **Out-of-roundness**

**0.020 mm (0.0008 in) or less**

#### **Taper limit**

**0.07 mm (0.0028 in)**

#### **Grinding limit**

**0.250 mm (0.0098 in)**

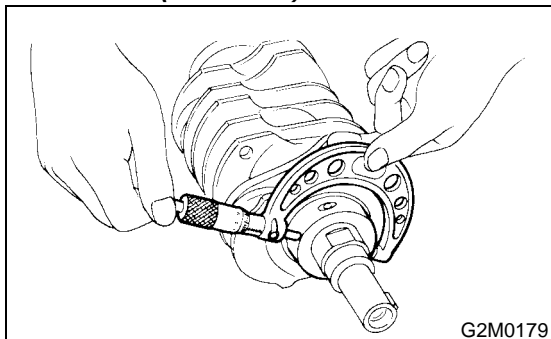



# CYLINDER BLOCK

MECHANICAL

|                            |                                       | Crank journal diameter               |                                      | Unit: mm (in)                        |
|----------------------------|---------------------------------------|--------------------------------------|--------------------------------------|--------------------------------------|
|                            |                                       | #1, #3, #5                           | #2, #4                               | Crank pin diameter                   |
| Standard                   | Journal O.D.                          | 59.992 — 60.008<br>(2.3619 — 2.3625) | 59.992 — 60.008<br>(2.3619 — 2.3625) | 47.984 — 48.000<br>(1.8891 — 1.8898) |
|                            | Bearing size<br>(Thickness at center) | 1.998 — 2.011<br>(0.0787 — 0.0792)   | 2.000 — 2.013<br>(0.0787 — 0.0793)   | 1.492 — 1.510<br>(0.0587 — 0.0591)   |
| 0.03 (0.0012)<br>undersize | Journal O.D.                          | 59.962 — 59.978<br>(2.3607 — 2.3613) | 59.962 — 59.978<br>(2.3607 — 2.3613) | 47.954 — 47.970<br>(1.8879 — 1.8886) |
|                            | Bearing size<br>(Thickness at center) | 2.017 — 2.020<br>(0.0794 — 0.0795)   | 2.019 — 2.022<br>(0.0795 — 0.0796)   | 1.510 — 1.513<br>(0.0594 — 0.0596)   |
| 0.05 (0.0020)<br>undersize | Journal O.D.                          | 59.942 — 59.958<br>(2.3599 — 2.3605) | 59.942 — 59.958<br>(2.3599 — 2.3605) | 47.934 — 47.950<br>(1.8872 — 1.8878) |
|                            | Bearing size<br>(Thickness at center) | 2.027 — 2.030<br>(0.0798 — 0.0799)   | 2.029 — 2.032<br>(0.0799 — 0.0800)   | 1.520 — 1.523<br>(0.0598 — 0.0600)   |
| 0.25 (0.0098)<br>undersize | Journal O.D.                          | 59.742 — 59.758<br>(2.3520 — 2.3527) | 59.742 — 59.758<br>(2.3520 — 2.3527) | 47.734 — 47.750<br>(1.8793 — 1.8799) |
|                            | Bearing size<br>(Thickness at center) | 2.127 — 2.130<br>(0.0837 — 0.0839)   | 2.129 — 2.132<br>(0.0838 — 0.0839)   | 1.620 — 1.623<br>(0.0638 — 0.0639)   |

O.D. ... Outer Diameter

4) Measure the thrust clearance of crankshaft at center bearing. If the clearance exceeds the limit, replace bearing.

**Crankshaft thrust clearance:**

**Standard**

**0.030 — 0.115 mm (0.0012 — 0.0045 in)**

**Limit**

**0.25 mm (0.0098 in)**

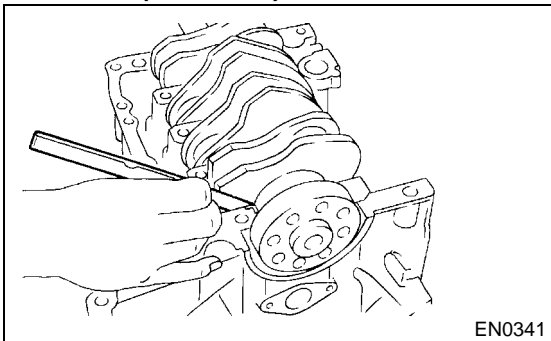

5) Inspect individual crankshaft bearings for signs of flaking, seizure, melting, and wear.

6) Measure the oil clearance on each crankshaft bearing by means of plastigauge. If the measurement is not within the specification, replace defective bearing with an undersize one, and replace or recondition crankshaft as necessary.

| Unit: mm (in)            |                                 |
|--------------------------|---------------------------------|
| Crankshaft oil clearance |                                 |
| Standard                 | 0.010 — 0.030 (0.0004 — 0.0012) |
| Limit                    | 0.040 (0.0016)                  |

# ENGINE TROUBLE IN GENERAL

MECHANICAL

## 21.Engine Trouble in General

### A: INSPECTION

NOTE:

“RANK” shown in the chart refer to the possibility of reason for the trouble in order (“Very often” to “Rarely”)

A — Very often

B — Sometimes

C — Rarely

| TROUBLE   | PROBLEM PARTS, ETC.   | POSSIBLE CAUSE                                     | RANK |
|---|---|--|------|
| 1. Engine will not start.                         |   |  |      |
| 1) Starter does not turn.                         | • Starter   | • Defective battery-to-starter harness             | B    |
|   |   | • Defective starter switch                         | C    |
|   |   | • Defective inhibitor switch or neutral switch     | C    |
|   |   | • Defective starter                                | B    |
|   | • Battery   | • Poor terminal connection                         | A    |
|   |   | • Run-down battery                                 | A    |
|   |   | • Defective charging system                        | B    |
|   | • Friction  | • Seizure of crankshaft and connecting rod bearing | C    |
|   |   | • Seized camshaft                                  | C    |
| • Seized or stuck piston and cylinder             |   | C  |      |
| 2) Initial combustion does not occur.             | • Starter   | • Defective starter                                | C    |
|   | • Engine control system <Ref. to EN(DOHC TURBO)-2, Basic Diagnostic Procedure.> |  | A    |
|   | • Fuel line   | • Defective fuel pump and relay                    | A    |
|   |   | • Lack of or insufficient fuel                     | B    |
|   | • Belt  | • Defective  | B    |
|   |   | • Defective timing                                 | B    |
|   | • Compression   | • Incorrect valve clearance                        | C    |
|   |   | • Loosened spark plugs or defective gasket         | C    |
|   |   | • Loosened cylinder head bolts or defective gasket | C    |
|   |   | • Improper valve seating                           | C    |
|   |   | • Defective valve stem                             | C    |
|   |   | • Worn or broken valve spring                      | B    |
|   |   | • Worn or stuck piston rings, cylinder and piston  | C    |
| • Incorrect valve timing                          |   | B  |      |
| • Improper engine oil (low viscosity)             | B   |  |      |
| 3) Initial combustion occur.                      | • Engine control system <Ref. to EN(DOHC TURBO)-2, Basic Diagnostic Procedure.> |  | A    |
|   | • Intake system   | • Defective intake manifold gasket                 | B    |
|   |   | • Defective throttle body gasket                   | B    |
|   | • Fuel line   | • Defective fuel pump and relay                    | C    |
|   |   | • Clogged fuel line                                | C    |
|   |   | • Lack of or insufficient fuel                     | B    |
|   | • Belt  | • Defective  | B    |
|   |   | • Defective timing                                 | B    |
|   | • Compression   | • Incorrect valve clearance                        | C    |
|   |   | • Loosened spark plugs or defective gasket         | C    |
|   |   | • Loosened cylinder head bolts or defective gasket | C    |
|   |   | • Improper valve seating                           | C    |
|   |   | • Defective valve stem                             | C    |
| • Worn or broken valve spring                     |   | B  |      |
| • Worn or stuck piston rings, cylinder and piston |   | C  |      |
| • Incorrect valve timing                          |   | B  |      |
| • Improper engine oil (low viscosity)             | B   |  |      |

# ENGINE TROUBLE IN GENERAL

MECHANICAL

| TROUBLE   | PROBLEM PARTS, ETC.   | POSSIBLE CAUSE                                       | RANK |
|---|---|--|------|
| 4) Engine stalls after initial combustion.        | • Engine control system <Ref. to EN(DOHC TURBO)-2, Basic Diagnostic Procedure.> |  | A    |
|   | • Intake system   | • Loosened or cracked intake duct                    | B    |
|   |   | • Loosened or cracked PCV hose                       | C    |
|   |   | • Loosened or cracked vacuum hose                    | C    |
|   |   | • Defective intake manifold gasket                   | B    |
|   |   | • Defective throttle body gasket                     | B    |
|   |   | • Dirty air cleaner element                          | C    |
|   | • Fuel line   | • Clogged fuel line                                  | C    |
|   |   | • Lack of or insufficient fuel                       | B    |
|   | • Belt  | • Defective  | B    |
|   |   | • Defective timing                                   | B    |
|   | • Compression   | • Incorrect valve clearance                          | C    |
|   |   | • Loosened spark plugs or defective gasket           | C    |
|   |   | • Loosened cylinder head bolts or defective gasket   | C    |
|   |   | • Improper valve seating                             | C    |
|   |   | • Defective valve stem                               | C    |
|   |   | • Worn or broken valve spring                        | B    |
| • Worn or stuck piston rings, cylinder and piston |   | C  |      |
| • Incorrect valve timing                          |   | B  |      |
| • Improper engine oil (low viscosity)             |   | B  |      |
| 2. Rough idle and engine stall                    | • Engine control system <Ref. to EN(DOHC TURBO)-2, Basic Diagnostic Procedure.> |  | A    |
|   | • Intake system   | • Loosened or cracked intake duct                    | A    |
|   |   | • Loosened or cracked PCV hose                       | A    |
|   |   | • Loosened or cracked vacuum hose                    | A    |
|   |   | • Defective intake manifold gasket                   | B    |
|   |   | • Defective throttle body gasket                     | B    |
|   |   | • Defective PCV valve                                | C    |
|   |   | • Loosened oil filter cap                            | B    |
|   |   | • Dirty air cleaner element                          | C    |
|   | • Fuel line   | • Defective fuel pump and relay                      | C    |
|   |   | • Clogged fuel line                                  | C    |
|   |   | • Lack of or insufficient fuel                       | B    |
|   | • Belt  | • Defective timing                                   | C    |
|   | • Compression   | • Incorrect valve clearance                          | B    |
|   |   | • Loosened spark plugs or defective gasket           | B    |
|   |   | • Loosened cylinder head bolts or defective gasket   | B    |
|   |   | • Improper valve seating                             | B    |
|   |   | • Defective valve stem                               | C    |
|   |   | • Worn or broken valve spring                        | B    |
|   |   | • Worn or stuck piston rings, cylinder and piston    | B    |
|   |   | • Incorrect valve timing                             | A    |
|   |   | • Improper engine oil (low viscosity)                | B    |
|   | • Lubrication system  | • Incorrect oil pressure                             | B    |
|   |   | • Defective rocker cover gasket                      | C    |
|   | • Cooling system  | • Overheating  | C    |
|   | • Others  | • Malfunction of evaporative emission control system | A    |
|   |   | • Stuck or damaged throttle valve                    | B    |
|   |   | • Accelerator cable out of adjustment                | C    |

# ENGINE TROUBLE IN GENERAL

MECHANICAL

| TROUBLE   | PROBLEM PARTS, ETC.   | POSSIBLE CAUSE                                     | RANK |
|---|---|--|------|
| 3. Low output, hesitation and poor acceleration | • Engine control system <Ref. to EN(DOHC TURBO)-2, Basic Diagnostic Procedure.> |  | A    |
|   | • Intake system   | • Loosened or cracked intake duct                  | A    |
|   |   | • Loosened or cracked PCV hose                     | A    |
|   |   | • Loosened or cracked vacuum hose                  | B    |
|   |   | • Defective intake manifold gasket                 | B    |
|   |   | • Defective throttle body gasket                   | B    |
|   |   | • Defective PCV valve                              | B    |
|   |   | • Loosened oil filter cap                          | B    |
|   |   | • Dirty air cleaner element                        | A    |
|   | • Fuel line   | • Defective fuel pump and relay                    | B    |
|   |   | • Clogged fuel line                                | B    |
|   |   | • Lack of or insufficient fuel                     | C    |
|   | • Belt  | • Defective timing                                 | B    |
|   | • Compression   | • Incorrect valve clearance                        | B    |
|   |   | • Loosened spark plugs or defective gasket         | B    |
|   |   | • Loosened cylinder head bolts or defective gasket | B    |
|   |   | • Improper valve seating                           | B    |
|   |   | • Defective valve stem                             | C    |
|   |   | • Worn or broken valve spring                      | B    |
|   |   | • Worn or stuck piston rings, cylinder and piston  | C    |
|   |   | • Incorrect valve timing                           | A    |
| • Improper engine oil (low viscosity)           | B   |  |      |
| • Lubrication system                            | • Incorrect oil pressure  | B  |      |
| • Cooling system                                | • Overheating   | C  |      |
|   | • Over cooling  | C  |      |
| • Others  | • Malfunction of evaporative emission control system                            | A  |      |
| 4. Surging                                      | • Engine control system <Ref. to EN(DOHC TURBO)-2, Basic Diagnostic Procedure.> |  | A    |
|   | • Intake system   | • Loosened or cracked intake duct                  | A    |
|   |   | • Loosened or cracked PCV hose                     | A    |
|   |   | • Loosened or cracked vacuum hose                  | A    |
|   |   | • Defective intake manifold gasket                 | B    |
|   |   | • Defective throttle body gasket                   | B    |
|   |   | • Defective PCV valve                              | B    |
|   |   | • Loosened oil filter cap                          | B    |
|   |   | • Dirty air cleaner element                        | B    |
|   | • Fuel line   | • Defective fuel pump and relay                    | B    |
|   |   | • Clogged fuel line                                | B    |
|   |   | • Lack of or insufficient fuel                     | C    |
|   | • Belt  | • Defective timing                                 | B    |
|   | • Compression   | • Incorrect valve clearance                        | B    |
|   |   | • Loosened spark plugs or defective gasket         | C    |
|   |   | • Loosened cylinder head bolts or defective gasket | C    |
|   |   | • Improper valve seating                           | C    |
|   |   | • Defective valve stem                             | C    |
|   |   | • Worn or broken valve spring                      | C    |
|   |   | • Worn or stuck piston rings, cylinder and piston  | C    |
|   |   | • Incorrect valve timing                           | A    |
| • Improper engine oil (low viscosity)           | B   |  |      |
| • Cooling system                                | • Overheating   | B  |      |
| • Others  | • Malfunction of evaporative emission control system                            | C  |      |

# ENGINE TROUBLE IN GENERAL

MECHANICAL

| TROUBLE                             | PROBLEM PARTS, ETC.   | POSSIBLE CAUSE   | RANK |
|-------------------------------------|---|--|------|
| 5. Engine does not return to idle.  | • Engine control system <Ref. to EN(DOHC TURBO)-2, Basic Diagnostic Procedure.> |  | A    |
|                                     | • Intake system   | • Loosened or cracked vacuum hose                        | A    |
|                                     | • Others  | • Stuck or damaged throttle valve                        | A    |
|                                     |   | • Accelerator cable out of adjustment                    | B    |
| 6. Dieseling (Run-on)               | • Engine control system <Ref. to EN(DOHC TURBO)-2, Basic Diagnostic Procedure.> |  | A    |
|                                     | • Cooling system  | • Overheating  | B    |
|                                     | • Others  | • Malfunction of evaporative emission control system     | B    |
| 7. After burning in exhaust system  | • Engine control system <Ref. to EN(DOHC TURBO)-2, Basic Diagnostic Procedure.> |  | A    |
|                                     | • Intake system   | • Loosened or cracked intake duct                        | C    |
|                                     |   | • Loosened or cracked PCV hose                           | C    |
|                                     |   | • Loosened or cracked vacuum hose                        | B    |
|                                     |   | • Defective PCV valve                                    | B    |
|                                     |   | • Loosened oil filler cap                                | C    |
|                                     | • Belt  | • Defective timing                                       | B    |
|                                     | • Compression   | • Incorrect valve clearance                              | B    |
|                                     |   | • Loosened spark plugs or defective gasket               | C    |
|                                     |   | • Loosened cylinder head bolts or defective gasket       | C    |
|                                     |   | • Improper valve seating                                 | B    |
|                                     |   | • Defective valve stem                                   | C    |
|                                     |   | • Worn or broken valve spring                            | C    |
|                                     |   | • Worn or stuck piston rings, cylinder and piston        | C    |
|                                     |   | • Incorrect valve timing                                 | A    |
| • Lubrication system                | • Incorrect oil pressure  | C  |      |
| • Cooling system                    | • Over cooling  | C  |      |
| • Others                            | • Malfunction of evaporative emission control system                            | C  |      |
| 8. Knocking                         | • Engine control system <Ref. to EN(DOHC TURBO)-2, Basic Diagnostic Procedure.> |  | A    |
|                                     | • Intake system   | • Loosened oil filter cap                                | B    |
|                                     | • Belt  | • Defective timing                                       | B    |
|                                     | • Compression   | • Incorrect valve clearance                              | C    |
|                                     |   | • Incorrect valve timing                                 | B    |
|                                     | • Cooling system  | • Overheating  | A    |
| 9. Excessive engine oil consumption | • Intake system   | • Loosened or cracked PCV hose                           | A    |
|                                     |   | • Defective PCV valve                                    | B    |
|                                     |   | • Loosened oil filter cap                                | C    |
|                                     | • Compression   | • Defective valve stem                                   | A    |
|                                     |   | • Worn or stuck piston rings, cylinder and piston        | A    |
|                                     | • Lubrication system  | • Loosened oil pump attaching bolts and defective gasket | B    |
|                                     |   | • Defective oil filter seal                              | B    |
|                                     |   | • Defective crankshaft oil seal                          | B    |
|                                     |   | • Defective rocker cover gasket                          | B    |
|                                     |   | • Loosened oil drain plug or defective gasket            | B    |
|                                     | • Loosened oil pan fitting bolts or defective oil pan                           | B  |      |

# ENGINE TROUBLE IN GENERAL

MECHANICAL

| TROUBLE                        | PROBLEM PARTS, ETC.   | POSSIBLE CAUSE                                     | RANK |   |
|--------------------------------|---|--|------|---|
| 10. Excessive fuel consumption | • Engine control system <Ref. to EN(DOHC TURBO)-2, Basic Diagnostic Procedure.> |  | A    |   |
|                                | • Intake system   | • Dirty air cleaner element                        | A    |   |
|                                | • Belt  | • Defective timing                                 | B    |   |
|                                | • Compression   | • Incorrect valve clearance                        |      | B |
|                                |   | • Loosened spark plugs or defective gasket         |      | C |
|                                |   | • Loosened cylinder head bolts or defective gasket |      | C |
|                                |   | • Improper valve seating                           |      | B |
|                                |   | • Defective valve stem                             |      | C |
|                                |   | • Worn or broken valve spring                      |      | C |
|                                |   | • Worn or stuck piston rings, cylinder and piston  |      | B |
|                                |   | • Incorrect valve timing                           |      | B |
|                                | • Lubrication system  | • Incorrect oil pressure                           |      | C |
|                                | • Cooling system  | • Over cooling                                     |      | C |
| • Others                       | • Accelerator cable out of adjustment   |  | B    |   |

# ENGINE NOISE

MECHANICAL

## 22.Engine Noise

### A: INSPECTION

| Type of sound   | Condition  | Possible cause  |
|---|--|---|
| Regular clicking sound  | Sound increases as engine speed increases.   | <ul style="list-style-type: none"> <li>• Valve mechanism is defective.</li> <li>• Incorrect valve clearance</li> <li>• Worn valve rocker</li> <li>• Worn camshaft</li> <li>• Broken valve spring</li> </ul> |
| Heavy and dull clank  | Oil pressure is low.   | <ul style="list-style-type: none"> <li>• Worn crankshaft main bearing</li> <li>• Worn connecting rod bearing (big end)</li> </ul>   |
|   | Oil pressure is normal.  | <ul style="list-style-type: none"> <li>• Loose flywheel mounting bolts</li> <li>• Damaged engine mounting</li> </ul>  |
| High-pitched clank (Spark knock)  | Sound is noticeable when accelerating with an overload.                                  | <ul style="list-style-type: none"> <li>• Ignition timing advanced</li> <li>• Accumulation of carbon inside combustion chamber</li> <li>• Wrong spark plug</li> <li>• Improper gasoline</li> </ul>           |
| Clank when engine speed is medium (1,000 to 2,000 rpm).                       | Sound is reduced when fuel injector connector of noisy cylinder is disconnected. (NOTE*) | <ul style="list-style-type: none"> <li>• Worn crankshaft main bearing</li> <li>• Worn bearing at crankshaft end of connecting rod</li> </ul>  |
| Knocking sound when engine is operating under idling speed and engine is warm | Sound is reduced when fuel injector connector of noisy cylinder is disconnected. (NOTE*) | <ul style="list-style-type: none"> <li>• Worn cylinder liner and piston ring</li> <li>• Broken or stuck piston ring</li> <li>• Worn piston pin and hole at piston end of connecting rod</li> </ul>          |
|   | Sound is not reduced if each fuel injector connector is disconnected in turn. (NOTE*)    | <ul style="list-style-type: none"> <li>• Unusually worn valve lifter</li> <li>• Worn cam gear</li> <li>• Worn camshaft journal bore in crankcase</li> </ul>   |
| Squeaky sound   | —  | <ul style="list-style-type: none"> <li>• Insufficient generator lubrication</li> </ul>  |
| Rubbing sound   | —  | <ul style="list-style-type: none"> <li>• Defective generator brush and rotor contact</li> </ul>   |
| Gear scream when starting engine  | —  | <ul style="list-style-type: none"> <li>• Defective ignition starter switch</li> <li>• Worn gear and starter pinion</li> </ul>   |
| Sound like polishing glass with a dry cloth                                   | —  | <ul style="list-style-type: none"> <li>• Loose drive belt</li> <li>• Defective water pump shaft</li> </ul>  |
| Hissing sound   | —  | <ul style="list-style-type: none"> <li>• Loss of compression</li> <li>• Air leakage in air intake system, hoses, connections or manifolds</li> </ul>  |
| Timing belt noise   | —  | <ul style="list-style-type: none"> <li>• Loose timing belt</li> <li>• Belt contacting case/adjacent part</li> </ul>   |
| Valve tappet noise  | —  | <ul style="list-style-type: none"> <li>• Incorrect valve clearance</li> </ul>   |

**NOTE\*:**

When disconnecting fuel injector connector, Malfunction Indicator Light (CHECK ENGINE light) illuminates and trouble code is stored in ECM memory.

Therefore, carry out the CLEAR MEMORY MODE <Ref. to EN(DOHC TURBO)-38, OPERATION, Clear Memory Mode.> and INSPECTION MODE <Ref. to EN(DOHC TURBO)-35, OPERATION, Inspection Mode.> after connecting fuel injector connector.