

NEW CAR INFORMATION SECTION

FOREWORD

This manual has been prepared to provide information for the construction, operation and other technical details of SUBARU vehicles. Read this manual thoroughly and make the most of it to give better service to your customers and improve your knowledge of vehicle maintenance.

All information, illustration and specifications contained in this manual are based on the latest product information available at the time of publication approval.

FUJI HEAVY INDUSTRIES LTD.

Specifications	SPC
Fuel Injection (Fuel System)	FU (TURBO)
Emission Control (Aux. Emission Control Devices)	EC (TURBO)
Intake (Induction)	IN (TURBO)
Mechanical	ME (TURBO)
Control System	CS
Manual Transmission and Differential	6MT
Clutch	CL
Front Suspension	FS
Rear Suspension	RS
Differentials	DI
Drive Shaft System	DS
ABS	ABS
Brakes	BR
Instrumentation/Driver Info	IDI

FOREWORD

All right reserved. This book may not be reproduced or copied, in whole or in part, without the written permission of FUJI HEAVY INDUSTRIES LTD., TOKYO JAPAN

SUBARU,  and  are trademarks of FUJI HEAVY INDUSTRIES LTD.

© Copyright 2001 FUJI HEAVY INDUSTRIES LTD.

SPECIFICATIONS

SPC

Page

1. Impreza	2
------------------	---

IMPREZA

Specifications

1. Impreza

A: DIMENSIONS

Model			Sedan	Wagon	OUTBACK	STi
Overall length		mm (in)	4,405 (173.4)			
Overall width		mm (in)	1,730 (68.1)	1,695 (66.7)	1,710 (67.3)	1,730 (68.1)
Overall height (at CW)		mm (in)	1,440 (56.7)	1,465 (57.7), 1,485 (58.5)★4	1,475 (58.1), 1,495 (58.9)★4	1,440 (56.7)
Compartment	Length	mm (in)	1,890 (74.4)	1,845 (72.6)		1,890 (74.4)
	Width	mm (in)	1,380 (54.3)			
	Height	mm (in)	1,180 (46.5), 1,125 (44.3)★5	1,200 (47.2), 1,150 (45.3)★5	1,200 (47.2), 1,150 (45.3)★5	1,180 (46.5)
Wheelbase		mm (in)	2,525 (99.4)			
Tread	Front	mm (in)	1,485 (58.5)	1,460 (57.5)★1, 1,465 (57.7)	1,460 (57.5)	1,490 (58.7)
	Rear	mm (in)	1,475 (58.1), 1,480 (58.3)★3	1,450 (57.1)★1, 1,455 (57.3)	1,455 (57.3)	1,480 (58.3)
Minimum road clearance	Without catalytic converter	mm (in)	150 (5.9), 155 (6.1)★2	150 (5.9), 155 (6.1)★2	160 (6.3)	—
	With catalytic converter	mm (in)	150 (5.9), 155 (6.1)★3	150 (5.9), 155 (6.1)★3	160 (6.3)	155 (6.1)

★1:1.6 L

★2:2.0 L

★3:2.0 L Turbo

★4:With roof rail

★5:With sun roof

B: ENGINE

Model			1.6 L	Non-Turbo 2.0 L	Turbo 2.0 L	2.5 L	STi
Engine type			Horizontally opposed, liquid cooled, 4-cylinder, 4-stroke gasoline engine				
Valve arrangement			Overhead camshaft type				
Bore x Stroke		mm (in)	87.9 x 65.8 (3.461 x 2.591)	92 x 75 (3.62 x 2.95)		99.5 x 79 (3.92 x 3.11)	92 x 75 (3.62 x 2.95)
Displacement		cm ³ (cu in)	1,597 (97.45)	1,994 (121.67)		2,475 (151.02)	1,994 (121.67)
Compression ratio			10.0 ± 0.2		8.0 ± 0.2	10.0 ± 0.2	8.0 ± 0.2
Firing order			1 — 3 — 2 — 4				
Idle speed at Park/Neutral position		rpm	700 ± 100		750 ± 100	700 ± 100	700 ± 100
Maximum output		kW (HP)/rpm	70 (94)/5,200	92 (123)/5,600	160 (215)/5,600	112 (150)/5,600	195 (261)/600
Maximum torque		N.m (kgf-m, ft-lb)/rpm	143 (14.6, 105.5)/3,600	184 (18.8, 136.0)/3,600	292 (29.8, 215.4)/3,600	223 (22.7, 164.5)/3,600	343 (35.0, 253.0)/4,000

C: ELECTRICAL

Model			1.6 L	Non-Turbo 2.0 L	Turbo 2.0 L	2.5 L	STi		
Ignition timing at idling speed			BTDC/rpm		5° ± 10°/700	10° ± 10°/700	12° ± 10°/750	MT: 10° ± 10°/700 AT: 15° ± 10°/700	12° ± 10°/700
Spark plug	Type and manufacturer	Without OBD	NGK: BKR6E (without catalyst) CHAMPION: RC8YC4 (with catalyst) NGK: BKR6E-11 (with catalyst)	NGK: BKR6E (without catalyst) CHAMPION: RC10YC4 (with catalyst) NGK: BKR5E-11 (with catalyst)	—	NGK: BKR6E (without catalyst) CHAMPION: RC10YC4 (with catalyst) NGK: BKR5E-11 (with catalyst)	—		
		With OBD	CHAMPION: RC8YC4	CHAMPION: RC10YC4	NGK: PFR6G	CHAMPION: RC10YC4	NGK: PFR6G		
			Alternate NGK: BKR6E-11	Alternate NGK: BKR5E-11		Alternate NGK: BKR6E-11			
Generator			12V — 75A						
Battery	Type and capacity (5HR)	For Europe and South America	12V — 48AH (55D23L)	MT: 12V — 48AH (55D23L) AT: 12V — 52AH (65D23L)		MT: 12V — 48AH (55D23L) AT: 12V — 52AH (75D23L)	12V — 48AH (55D23L)		
		Others	12V — 27AH (34B19L)					—	

IMPREZA

Specifications

D: TRANSMISSION

Model		1.6 L		Non-Turbo 2.0 L		Turbo 2.0 L		2.5 L		STi	
Transmission type		5MT	4AT	5MT	4AT	5MT	4AT	5MT	4AT	6MT	
Clutch type		DSPD	TCC	DSPD	TCC	DSPD	TCC	DSPD	TCC	DSPD	
Gear ratio	1st	3.454	2.785	3.454	2.785	3.454, 3.166★1	2.785	3.454	2.785	3.636	
	2nd	2.062	1.545	2.062	1.545	1.947, 1.882★1	1.545	2.062	1.545	2.375	
	3rd	1.448	1.000	1.448	1.000	1.366, 1.296★1	1.000	1.448	1.000	1.761	
	4th	1.088	0.694	1.088	0.694	0.972	0.694	1.088	0.694	1.346	
	5th	0.825	—	0.825	—	0.738	—	0.871, 0.780★1	—	0.971, 1.062 ★1	
	6th	—	—	—	—	—	—	—	—	0.756, 0.842 ★1	
	Reverse	3.333	2.272	3.333	2.272	3.333	2.272	3.333	2.272	3.545	
	Dual range	1.447	—	1.447	—	—	—	—	—	—	
Reduction gear (Front drive)	1st reduction	Type of gear	—	Helical	—	Helical	—	Helical	—	Helical	—
		Gear ratio	—	1.000	—	1.000	—	1.000	—	1.000	—
	Final reduction	Type of gear	Hypoid	Hypoid	Hypoid	Hypoid	Hypoid	Hypoid	Hypoid	Hypoid	Hypoid
		Gear ratio	4.111	4.444	3.900	4.111	3.900, 4.444★1	4.111	3.700, 4.111★1	4.111	3.900
Reduction gear (Rear drive)	Transfer reduction	Type of gear	Helical	—	Helical	—	Helical	—	Helical	—	Helical
		Gear ratio	1.000	—	1.000	—	1.100, 1.000★1	—	1.000	—	1.100, 1.000 ★1
	Final reduction	Type of gear	Hypoid	Hypoid	Hypoid	Hypoid	Hypoid	Hypoid	Hypoid	Hypoid	Hypoid
		Gear ratio	4.111	4.444	3.900	4.111	3.545, 4.444★1	4.111	3.700, 4.111★1	4.111	3.545, 3.900 ★1

5MT:5-forward speeds with synchromesh and 1-reverse

4AT:Electronically controlled fully-automatic, 4-forward speeds and 1-reverse

6MT:6-forward speeds with synchromesh and 1-reverse

DSPD:Dry Single Plate Diaphragm

TCC:Torque Converter Clutch

★1:Australia spec vehicle

E: STEERING

Model		Turbo 2.0 L, 2.5 L	OUTBACK	OTHERS	STi
Type		Rack and Pinion			
Turns, lock to lock		RHD: 2.7 LHD: 3.0	3.0	3.2	2.7
Minimum turning circle	m (ft)				
	Curb to curb	11.0 (36.1)	10.8 (35.4)	10.4 (34.1)	11.0
	Wall to wall	12.0 (39.4)	11.6 (38.1)	11.2 (36.7)	12.0

F: SUSPENSION

Front	Macpherson strut type, Independent, Coil spring
Rear	Dual-link type, Independent, Coil spring

G: BRAKE

Model	1.6 L	Non-Turbo 2.0 L, 2.5 L	Turbo 2.0 L, STi
Service brake system	Dual circuit hydraulic with vacuum suspended power unit		
Front	Ventilated disc brake		
Rear	Drum brake	Disc brake	Ventilated disc brake
Parking brake	Mechanical on rear brakes		

H: TIRE

Rim size	14 x 5 1/2 JJ	15 x 6JJ	16 x 6 1/2 JJ	17 x 7JJ	17 x 7 1/2 JJ
Tire size	175/70R14 84T 185/70R14 88H	185/65R15 88H 195/60R15 88H	P205/55R16 89V 205/50R16 87V	215/45R17 87W	225/45R17 90W 215/45R17 87W
Type	Steel belted radial, Tubeless				

I: CAPACITY

Model		1.6 L		Non-Turbo 2.0 L		Turbo 2.0 L		2.5 L		STi
		5MT	4AT	5MT	4AT	5MT	4AT	5MT	4AT	6MT
Fuel tank	ℓ (US gal, Imp gal)	50 (13.2, 11.0)				60 (15.9, 13.2)				
Engine oil	Total capacity ℓ (US qt, Imp qt)	4.0 (4.2, 3.5)				4.5 (4.8, 4.0)		4.0 (4.2, 3.5)		4.5 (4.8, 4.0)
	Engine oil amount for refill ℓ (US qt, Imp qt)	Approx. 4.0 (4.2, 3.5)				Approx. 4.5 (4.8, 4.0)		Approx. 4.0 (4.2, 3.5)		Approx. 4.5 (4.8, 4.0)
Transmission gear oil	ℓ (US qt, Imp qt)	3.5 (3.7, 3.1), 4.0 (4.2, 3.5)★1	—	3.5 (3.7, 3.1), 4.0 (4.2, 3.5)★1	—	3.5 (3.7, 3.1)	—	3.5 (3.7, 3.1)	—	4.1 (4.3, 3.6)
Automatic transmission fluid	ℓ (US qt, Imp qt)	—	8.4 (8.9, 7.4)	—	8.4 (8.9, 7.4)	—	9.3 (9.8, 8.2)	—	9.3 (9.8, 8.2)	—
AT differential gear oil	ℓ (US qt, Imp qt)	—	1.2 (1.3, 1.1)	—	1.2 (1.3, 1.1)	—	1.2 (1.3, 1.1)	—	1.2 (1.3, 1.1)	—
AWD rear differential gear oil	ℓ (US qt, Imp qt)	0.8 (0.8, 0.6)								1.0 (1.1, 0.9)
Power steering fluid	ℓ (US qt, Imp qt)	0.7 (0.7, 0.6)								
Engine coolant	ℓ (US qt, Imp qt)	7.4 (7.8, 6.5)	7.3 (7.7, 6.4)	7.0 (7.4, 6.2)	6.9 (7.3, 6.1)	7.7 (8.1, 6.8)	7.7 (8.1, 6.8)	7.0 (7.4, 6.2)	6.9 (7.3, 6.1)	7.7 (8.1, 6.8)

★1: Dual range

IMPREZA

Specifications

J: WEIGHT

1. LHD VEHICLE

Sedan

Option code★1			EC		K4		K0		KS	
Model			1.6 L							
			AWD							
			TS							
			5MT	4AT	5MT	4AT	5MT	4AT	5MT	4AT
Curb weight (C.W.)	Front	kgf (lb)	730 (1,609)	750 (1,654)	750 (1,654)	770 (1,698)	750 (1,654)	770 (1,698)	740 (1,631)	760 (1,676)
	Rear	kgf (lb)	520 (1,146)	520 (1,146)	520 (1,146)	520 (1,146)	520 (1,146)	520 (1,146)	535 (1,179)	535 (1,179)
	Total	kgf (lb)	1,250 (2,755)	1,270 (2,800)	1,270 (2,800)	1,290 (2,844)	1,270 (2,800)	1,290 (2,844)	1,275 (2,810)	1,295 (2,855)
Maximum permissible axle weight (M.P.A.W.)	Front	kgf (lb)	890 (1,962)	890 (1,962)	890 (1,962)	890 (1,962)	890 (1,962)	890 (1,962)	890 (1,962)	890 (1,962)
	Rear	kgf (lb)	890 (1,962)	890 (1,962)	890 (1,962)	890 (1,962)	890 (1,962)	890 (1,962)	890 (1,962)	890 (1,962)
Maximum permissible weight (M.P.W.)	Total	kgf (lb)	1,700 (3,748)	1,700 (3,748)	1,700 (3,748)	1,700 (3,748)	1,700 (3,748)	1,700 (3,748)	1,700 (3,748)	1,700 (3,748)
Option	Air conditioner		—	—	○	○	○	○	○	○
	Cruise control		—	—	—	—	—	—	—	—
	ABS		—	—	—	—	—	—	—	—
	Aluminium wheel		—	—	—	—	—	—	—	—
	Rear spoiler		—	—	—	—	—	—	—	—
	Spoiler pac		—	—	—	—	—	—	—	—

★1:For option code, refer to ID section. <Ref. to ID-5, Option code.>

IMPREZA

Specifications

Option code★1			EC		K4		K0		KS	
Model			2.0 L							
			AWD							
			GX							
			5MT	4AT	5MT	4AT	5MT	4AT	5MT	4AT
Curb weight (C.W.)	Front	kgf (lb)	745 (1,643)	770 (1,698)	765 (1,687)	790 (1,742)	760 (1,676)	795 (1,753)	750 (1,653)	780 (1,720)
	Rear	kgf (lb)	535 (1,179)	530 (1,168)	530 (1,168)	525 (1,157)	525 (1,157)	530 (1,168)	550 (1,213)	545 (1,202)
	Total	kgf (lb)	1,280 (2,822)	1,300 (2,866)	1,295 (2,855)	1,315 (2,899)	1,285 (2,833)	1,325 (2,921)	1,300 (2,866)	1,325 (2,921)
Maximum permissible axle weight (M.P.A.W.)	Front	kgf (lb)	920 (2,028)	920 (2,028)	920 (2,028)	920 (2,028)	920 (2,028)	920 (2,028)	920 (2,028)	920 (2,028)
	Rear	kgf (lb)	910 (2,006)	910 (2,006)	910 (2,006)	910 (2,006)	910 (2,006)	910 (2,006)	910 (2,006)	910 (2,006)
Maximum permissible weight (M.P.W.)	Total	kgf (lb)	1,760 (3,880)	1,760 (3,880)	1,760 (3,880)	1,760 (3,880)	1,760 (3,880)	1,760 (3,880)	1,760 (3,880)	1,760 (3,880)
Option	Air conditioner		—	—	○	○	○	○	○	○
	Cruise control		—	—	—	—	—	—	—	—
	ABS		—	—	○	○	○	○	—	○
	Aluminium wheel		—	—	○	○	—	—	○	○
	Rear spoiler		—	—	—	—	—	—	○	○
	Spoiler pac		—	—	—	—	—	—	—	—

Option code★1			EC					
Model			2.5 L		2.0 L Turbo			
			AWD					
			RS		WRX	STi		
			5MT	4AT	5MT	6MT		
Curb weight (C.W.)	Front	kgf (lb)	760 (1,676)		785 (1,731)		815 (1,797)	875 (1,929)
	Rear	kgf (lb)	535 (1,179)		530 (1,168)		550 (1,213)	575 (1,268)
	Total	kgf (lb)	1,295 (2,855)		1,315 (2,899)		1,365 (3,009)	1,450 (3,197)
Maximum permissible axle weight (M.P.A.W.)	Front	kgf (lb)	930 (2,050)		930 (2,050)		970 (2,138)	1,030 (2,271)
	Rear	kgf (lb)	910 (2,006)		910 (2,006)		920 (2,028)	920 (2,028)
Maximum permissible weight (M.P.W.)	Total	kgf (lb)	1,780 (3,924)		1,780 (3,924)		1,850 (4,079)	1,880 (4,145)
Option	Air conditioner		—		—		—	—
	Cruise control		—		—		—	—
	ABS		○		○		○	○
	Aluminium wheel		—		—		—	—
	Rear spoiler		—		—		—	—
	Spoiler pac		—		—		—	—

★1:For option code, refer to ID section. <Ref. to ID-5, Option code.>

IMPREZA

Specifications

Wagon

Option code★1			EC		K4		K0		KS	
Model			1.6 L							
			AWD							
			TS							
			D/R	4AT	D/R	4AT	D/R	4AT	D/R	4AT
Curb weight (C.W.)	Front	kgf (lb)	735 (1,620)	750 (1,654)	755 (1,664)	770 (1,698)	755 (1,664)	770 (1,698)	745 (1,642)	760 (1,676)
	Rear	kgf (lb)	545 (1,202)	545 (1,202)	545 (1,202)	545 (1,202)	545 (1,202)	545 (1,202)	560 (1,235)	560 (1,235)
	Total	kgf (lb)	1,280 (2,822)	1,295 (2,855)	1,300 (2,866)	1,315 (2,900)	1,300 (2,866)	1,315 (2,900)	1,305 (2,877)	1,320 (2,911)
Maximum permissible axle weight (M.P.A.W.)	Front	kgf (lb)	900 (1,984)	900 (1,984)	900 (1,984)	900 (1,984)	900 (1,984)	900 (1,984)	900 (1,984)	900 (1,984)
	Rear	kgf (lb)	910 (2,006)	910 (2,006)	910 (2,006)	910 (2,006)	910 (2,006)	910 (2,006)	910 (2,006)	910 (2,006)
Maximum permissible weight (M.P.W.)	Total	kgf (lb)	1,730 (3,814)	1,730 (3,814)	1,730 (3,814)	1,730 (3,814)	1,730 (3,814)	1,730 (3,814)	1,730 (3,814)	1,730 (3,814)
Option	Air conditioner		—	—	○	○	○	○	○	○
	Cruise control		—	—	—	—	—	—	—	—
	ABS		—	—	—	—	—	—	—	—
	Aluminium wheel		—	—	—	—	—	—	—	—
	Rear spoiler		—	—	—	—	—	—	—	—
	Spoiler pac		—	—	—	—	—	—	—	—

D/R Dual range

★1:For option code, refer to ID section. <Ref. to ID-5, Option code.>

IMPREZA

Specifications

Option code★1			EC		K4		K0		KS	
Model			2.0 L							
			AWD							
			GX							
			D/R	4AT	D/R	4AT	D/R	4AT	D/R	4AT
Curb weight (C.W.)	Front	kgf (lb)	755 (1,664)	770 (1,698)	775 (1,709)	790 (1,742)	780 (1,720)	795 (1,753)	760 (1,676)	780 (1,720)
	Rear	kgf (lb)	570 (1,257)	565 (1,246)	565 (1,246)	560 (1,235)	570 (1,257)	565 (1,246)	580 (1,279)	575 (1,268)
	Total	kgf (lb)	1,325 (2,921)	1,335 (2,944)	1,340 (2,955)	1,350 (2,977)	1,350 (2,977)	1,360 (2,999)	1,340 (2,955)	1,355 (2,988)
Maximum permissible axle weight (M.P.A.W.)	Front	kgf (lb)	920 (2,028)	920 (2,028)	920 (2,028)	920 (2,028)	920 (2,028)	920 (2,028)	920 (2,028)	920 (2,028)
	Rear	kgf (lb)	960 (2,116)	960 (2,116)	960 (2,116)	960 (2,116)	960 (2,116)	960 (2,116)	960 (2,116)	960 (2,116)
Maximum permissible weight (M.P.W.)	Total	kgf (lb)	1,800 (3,969)	1,800 (3,969)	1,800 (3,969)	1,800 (3,969)	1,800 (3,969)	1,800 (3,969)	1,800 (3,969)	1,800 (3,969)
Option	Air conditioner		—	—	○	○	○	○	○	○
	Cruise control		—	—	—	—	—	—	—	—
	ABS		—	—	○	○	○	○	—	○
	Aluminium wheel		—	—	○	○	—	—	○	○
	Rear spoiler		—	—	—	—	—	—	—	—
	Spoiler pac		—	—	—	—	—	—	—	—

Option code★1			EC		K4	
Model			2.0 L Turbo			
			AWD			
			WRX			
			5MT			
Curb weight (C.W.)	Front	kgf (lb)	805 (1,775)		825 (1,819)	
	Rear	kgf (lb)	585 (1,290)		585 (1,290)	
	Total	kgf (lb)	1,390 (3,065)		1,410 (3,109)	
Maximum permissible axle weight (M.P.A.W.)	Front	kgf (lb)	970 (2,138)		970 (2,138)	
	Rear	kgf (lb)	950 (2,094)		950 (2,094)	
Maximum permissible weight (M.P.W.)	Total	kgf (lb)	1,860 (4,101)		1,860 (4,101)	
Option	Air conditioner		—		○	
	Cruise control		—		—	
	ABS		○		○	
	Aluminium wheel		—		—	
	Rear spoiler		—		—	
	Spoiler pac		—		—	

D/R Dual range

★1:For option code, refer to ID section. <Ref. to ID-5, Option code.>

IMPREZA

Specifications

2. RHD VEHICLE

Sedan

Option code★1			EK		K1	
Model			1.6 L			
			AWD			
			TS			
			5MT	4AT	5MT	4AT
Curb weight (C.W.)	Front	kgf (lb)	735 (1,621)	755 (1,665)	750 (1,654)	770 (1,698)
	Rear	kgf (lb)	520 (1,146)	520 (1,146)	520 (1,146)	520 (1,146)
	Total	kgf (lb)	1,255 (2,767)	1,275 (2,811)	1,270 (2,800)	1,290 (2,844)
Maximum permissible axle weight (M.P.A.W.)	Front	kgf (lb)	890 (1,962)	890 (1,962)	890 (1,962)	890 (1,962)
	Rear	kgf (lb)	890 (1,962)	890 (1,962)	890 (1,962)	890 (1,962)
Maximum permissible weight (M.P.W.)	Total	kgf (lb)	1,700 (3,748)	1,700 (3,748)	1,700 (3,748)	1,700 (3,748)
Option	Air conditioner		—	—	○	○
	Cruise control		—	—	—	—
	ABS		○	○	—	—
	Aluminium wheel		—	—	—	—
	Rear spoiler		—	—	—	—
	Spoiler pac		○	○	—	—

Option code★1			EK		K1	
Model			2.0 L			
			AWD			
			GX			
			5MT	4AT	5MT	4AT
Curb weight (C.W.)	Front	kgf (lb)	765 (1,687)	790 (1,742)	770 (1,698)	795 (1,753)
	Rear	kgf (lb)	535 (1,179)	530 (1,168)	535 (1,179)	530 (1,168)
	Total	kgf (lb)	1,300 (2,866)	1,320 (2,910)	1,305 (2,877)	1,325 (2,921)
Maximum permissible axle weight (M.P.A.W.)	Front	kgf (lb)	920 (2,028)	920 (2,028)	920 (2,028)	920 (2,028)
	Rear	kgf (lb)	910 (2,006)	910 (2,006)	910 (2,006)	910 (2,006)
Maximum permissible weight (M.P.W.)	Total	kgf (lb)	1,760 (3,880)	1,760 (3,880)	1,760 (3,880)	1,760 (3,880)
Option	Air conditioner		○	○	○	○
	Cruise control		—	—	—	—
	ABS		○	○	○	○
	Aluminium wheel		○	○	—	—
	Rear spoiler		○	○	—	—
	Spoiler pac		○	○	—	—

★1:For option code, refer to ID section. <Ref. to ID-5, Option code.>

IMPREZA

Specifications

Option code★1			KA						
Model			2.0 L		2.0 L Turbo		2.5 L		2.0 L Turbo
			AWD						
			GX		WRX		RS		STi
			5MT	4AT	5MT	4AT	5MT	4AT	6MT
Unladen mass (U. M.)	Front	kgf (lb)	750 (1,654)	775 (1,709)	830 (1,830)	855 (1,885)	780 (1,720)	805 (1,775)	895 (1,973)
	Rear	kgf (lb)	535 (1,179)	530 (1,168)	560 (1,235)	555 (1,224)	540 (1,191)	535 (1,179)	575 (1,268)
	Total	kgf (lb)	1,285 (2,833)	1,305 (2,877)	1,390 (3,065)	1,410 (3,109)	1,320 (2,910)	1,340 (2,954)	1,470 (3,241)
Gross vehicle mass (G. V. M.)	Front	kgf (lb)	920 (2,028)	920 (2,028)	970 (2,138)	970 (2,138)	930 (2,050)	930 (2,050)	1,030 (2,271)
	Rear	kgf (lb)	910 (2,006)	910 (2,006)	920 (2,028)	920 (2,028)	910 (2,006)	910 (2,006)	920 (2,028)
	Total	kgf (lb)	1,760 (3,880)	1,760 (3,880)	1,850 (4,079)	1,850 (4,079)	1,780 (3,924)	1,780 (3,924)	1,880 (4,145)
Option	Air conditioner		—	—	○	○	○	○	○
	Cruise control		○	○	○	○	○	○	○
	ABS		○	○	○	○	○	○	○
	Aluminium wheel		—	—	—	—	—	—	—
	Rear spoiler		—	—	○	○	○	○	—
	Spoiler pac		—	—	—	—	—	—	—

Option code★1			EK			
Model			2.0 L Turbo			
			AWD			
			WRX		STi	
			5MT		6MT	
Curb weight (C.W.)	Front	kgf (lb)	830 (1,830)		895 (1,973)	
	Rear	kgf (lb)	560 (1,235)		575 (1,268)	
	Total	kgf (lb)	1,390 (3,065)		1,470 (3,241)	
Maximum permissible axle weight (M.P.A.W.)	Front	kgf (lb)	970 (2,138)		1,030 (2,271)	
	Rear	kgf (lb)	920 (2,028)		920 (2,028)	
Maximum permissible weight (M.P.W.)	Total	kgf (lb)	1,850 (4,079)		1,880 (4,145)	
Option	Air conditioner		○		○	
	Cruise control		—		—	
	ABS		○		○	
	Aluminium wheel		—		—	
	Rear spoiler		○		—	
	Spoiler pac		—		—	

★1:For option code, refer to ID section. <Ref. to ID-5, Option code.>

IMPREZA

Specifications

Wagon

Option code★1			EK		K1	
Model			1.6 L			
			AWD			
			TS			
			D/R	4AT	D/R	4AT
Curb weight (C.W.)	Front	kgf (lb)	740 (1,631)	755 (1,664)	755 (1,664)	770 (1,698)
	Rear	kgf (lb)	545 (1,202)	545 (1,202)	545 (1,202)	545 (1,202)
	Total	kgf (lb)	1,285 (2,833)	1,300 (2,866)	1,300 (2,866)	1,315 (2,900)
Maximum permissible axle weight (M.P.A.W.)	Front	kgf (lb)	900 (1,984)	900 (1,984)	900 (1,984)	900 (1,984)
	Rear	kgf (lb)	910 (2,006)	910 (2,006)	910 (2,006)	910 (2,006)
Maximum permissible weight (M.P.W.)	Total	kgf (lb)	1,730 (3,814)	1,730 (3,814)	1,730 (3,814)	1,730 (3,814)
Option	Air conditioner		—	—	○	○
	Cruise control		—	—	—	—
	ABS		○	○	—	—
	Aluminium wheel		—	—	—	—
	Rear spoiler		—	—	—	—
	Spoiler pac		—	—	—	—

Option code★1			EK		K1	
Model			2.0 L			
			AWD			
			GX			
			D/R	4AT	D/R	4AT
Curb weight (C.W.)	Front	kgf (lb)	775 (1,709)	790 (1,742)	780 (1,720)	795 (1,753)
	Rear	kgf (lb)	570 (1,257)	565 (1,246)	570 (1,257)	565 (1,246)
	Total	kgf (lb)	1,345 (2,965)	1,355 (2,987)	1,350 (2,977)	1,360 (2,999)
Maximum permissible axle weight (M.P.A.W.)	Front	kgf (lb)	920 (2,028)	920 (2,028)	920 (2,028)	920 (2,028)
	Rear	kgf (lb)	960 (2,116)	960 (2,116)	960 (2,116)	960 (2,116)
Maximum permissible weight (M.P.W.)	Total	kgf (lb)	1,800 (3,968)	1,800 (3,968)	1,800 (3,968)	1,800 (3,968)
Option	Air conditioner		○	○	○	○
	Cruise control		—	—	—	—
	ABS		○	○	○	○
	Aluminium wheel		○	○	—	—
	Rear spoiler		—	—	—	—
	Spoiler pac		○	○	—	—

D/R Dual range

★1:For option code, refer to ID section. <Ref. to ID-5, Option code.>

IMPREZA

Specifications

Option code★1			KA					
Model			2.0 L				2.0 L Turbo	
			AWD					
			GX		OUTBACK		WRX	
			D/R	4AT	D/R	4AT	5MT	4AT
Unladen mass (U. M.)	Front	kgf (lb)	760 (1,676)	775 (1,709)	750 (1,653)	765 (1,687)	825 (1,819)	850 (1,874)
	Rear	kgf (lb)	570 (1,257)	565 (1,246)	570 (1,257)	570 (1,257)	585 (1,290)	585 (1,290)
	Total	kgf (lb)	1,330 (2,932)	1,340 (2,954)	1,320 (2,910)	1,335 (2,943)	1,410 (3,109)	1,435 (3,164)
Gross vehicle mass (G. V. M.)	Front	kgf (lb)	920 (2,028)	920 (2,028)	920 (2,028)	920 (2,028)	970 (2,138)	970 (2,138)
	Rear	kgf (lb)	960 (2,116)	960 (2,116)	960 (2,116)	960 (2,116)	950 (2,094)	950 (2,094)
	Total	kgf (lb)	1,800 (3,968)	1,800 (3,968)	1,800 (3,968)	1,800 (3,968)	1,860 (4,101)	1,860 (4,101)
Option	Air conditioner		—	—	—	—	○	○
	Cruise control		○	○	○	○	○	○
	ABS		○	○	○	○	○	○
	Aluminium wheel		—	—	—	—	—	—
	Rear spoiler		—	—	—	—	—	—
	Spoiler pac		—	—	—	—	—	—

Option code★1			EK					
Model			2.0 L Turbo					
			AWD					
			WRX					
			5MT					
Curb weight (C.W.)	Front	kgf (lb)	825 (1,819)					
	Rear	kgf (lb)	585 (1,290)					
	Total	kgf (lb)	1,410 (3,109)					
Maximum permissible axle weight (M.P.A.W.)	Front	kgf (lb)	970 (2,138)					
	Rear	kgf (lb)	950 (2,094)					
Maximum permissible weight (M.P.W.)	Total	kgf (lb)	1,860 (4,101)					
Option	Air conditioner		○					
	Cruise control		—					
	ABS		○					
	Aluminium wheel		—					
	Rear spoiler		—					
	Spoiler pac		—					

D/R Dual range

★1:For option code, refer to ID section. <Ref. to ID-5, Option code.>

MEMO

FUEL INJECTION (FUEL SYSTEM)

FU (TURBO)

	Page
1. General	
2. Air Line	2
3. Fuel Line	
4. Sensors and Switches	3
5. Control System	4
6. On-board Diagnosis System	

2. Air Line

G: TUMBLE GENERATOR VALVES

2. STi MODEL

The STi model's engine is not provided with a tumble generation control function. Although it is fitted with a tumble generator housing, there are no sensor and valve actuator on the housing.

4. Sensors and Switches

D: EXHAUST GAS TEMPERATURE SENSOR

2. STi MODEL

The STi model is not provided with an exhaust gas temperature sensor.

I: VARIABLE VALVE TIMING CAMSHAFT POSITION SENSORS

NOTE:

The variable valve timing camshaft position sensors are installed only on the STi model's engine.

- The variable valve timing camshaft position sensors are installed one each on the rear ends of the right and left bank cylinder heads.
- The sensor detects the amounts of the advance and retard angles of the intake valves caused by the effect of the variable valve timing system using the variation in the air gap between the sensor and a boss provided on the rear end of each intake camshaft. The sensor's internal construction and operation are same as those of the crankshaft position sensor.

CONTROL SYSTEM

Fuel Injection (Fuel System)

5. Control System

B: INPUT AND OUTPUT SIGNALS

Signal	Unit	Function
Input signals	Pressure sensor	Detects the amount of intake air (Measures the absolute pressure).
	Mass air flow and intake air temperature sensor	Detects the temperature and amount of intake air.
	Throttle position sensor	Detects the throttle valve position.
	Front oxygen (A/F) sensor	Detects the density of oxygen in exhaust gases at the upstream of the front catalytic converter.
	Rear oxygen sensor	Detects the density of oxygen in exhaust gases at the downstream of the rear catalytic converter.
	Exhaust gas temperature sensor (Except STi model)	Detects the exhaust gas temperature.
	Tumble generator valve position sensor (Except STi model)	Detects the tumble generator valve position.
	Crankshaft position sensor	Detects the crankshaft angular position.
	Camshaft position sensor	Detects the combustion cylinder.
	Variable valve timing camshaft position sensor (Only STi model)	Detects amounts of advance and retard angles of the intake valves.
	Engine coolant temperature sensor	Detects the engine coolant temperature.
	Knock sensor	Detects engine knocking.
	Vehicle speed sensor	Detects the vehicle speed.
	Ignition switch	Detects operation of the ignition switch.
	Starter switch	Detects the condition of engine cranking.
	Neutral position switch	Detects that the gear is in neutral.
	Heater circuit of front and rear oxygen sensor	Detects the abnormality in heater circuit of front and rear oxygen sensor.
	A/C switch	Detects ON-OFF operation of the A/C switch.
	Fuel level sensor	Detects the level of the fuel in the fuel tank.
	Small light switch	Detects ON-OFF operation of the small light switch.
Blower fan switch	Detects ON-OFF operation of the blower fan switch.	
Rear defogger switch	Detects ON-OFF operation of the rear defogger switch.	
Output signals	Fuel Injector	Activates an injector.
	Ignition signal	Turns the primary ignition current ON or OFF.
	Fuel pump controller	Controls the fuel pump.
	A/C control relay	Turns the A/C control relay ON or OFF.
	Radiator fan control relay	Turns the radiator fan control relay ON or OFF.
	Idle air control solenoid valve	Adjusts the amount of air flowing through the bypass line in the throttle body.
	Tumble generator valve actuator (Except STi model)	Operates the tumble generator valve.
	Wastegate control solenoid valve	Controls supercharging pressure
	Malfunction indicator lamp	Indicates existence of abnormality.
	Purge control solenoid valve	Controls purge of evaporative gas absorbed by the canister.
	Power supply	Controls ON/OFF of the main power supply relay.
Variable valve timing solenoid valve (Only STi model)	Controls advance and retard angles of the intake valves.	

EMISSION CONTROL (AUX. EMISSION CONTROL DEVICES)

EC (TURBO)

	Page
1. System Overview	2
2. Schematic Diagrams	
3. Crankcase Emission Control System	
4. Three-way Catalyst	
5. A/F Control System	
6. Ignition Control System	
7. Evaporative Emission Control System	
8. Vacuum Connections	

SYSTEM OVERVIEW

Emission Control (Aux. Emission Control Devices)

1. System Overview

There are three emission control systems which are as follows:

- Crankcase emission control system
- Exhaust emission control system
 - Three-way catalyst system
 - Air/fuel (A/F) control system
 - Ignition control system
- Evaporative emission control system

NOTE: The STi model is not provided with a precatalytic converter.

Item		Main components	Function	
Crankcase emission control system		Positive crankcase ventilation (PCV) valve	Draws blow-by gas into intake manifold from crankcase and burns it together with air-fuel mixture. Amount of blow-by gas to be drawn in is controlled by intake manifold pressure.	
Exhaust emission control system	Catalyst system	Three-way catalyst	Oxidizes HC and CO contained in exhaust gases as well as reducing NOx.	
				Pre (Except STi model)
				Front
		Rear		
	A/F control system	Engine control module (ECM)	Receives input signals from various sensors, compares signals with stored data, and emits a signal for optimal control of air-fuel mixture ratio.	
		Front oxygen (A/F) sensor	Detects quantity of oxygen contained exhaust gases.	
		Rear oxygen sensor	Detects density of oxygen contained exhaust gases.	
		Throttle position sensor	Detects throttle position.	
		Mass air flow sensor and intake air temperature sensor	Detects amount of intake air.	
			Detects intake air temperature of air cleaner case.	
Ignition control system	ECM	Receives various signals, compares signals with basic data stored in memory, and emits a signal for optimal control of ignition timing.		
	Crankshaft position sensor	Detects engine speed (Revolution).		
	Camshaft position sensor	Detects reference signal for combustion cylinder discrimination.		
	Engine coolant temperature sensor	Detects coolant temperature.		
	Knock sensor	Detects engine knocking.		
Evaporative emission control system	Canister	Absorbs evaporative gas which occurs in fuel tank when engine stops, and releases it to combustion chambers for a complete burn when engine is started. This prevents HC from being discharged into atmosphere.		
	Purge control solenoid valve	Receives a signal from ECM and controls purge of evaporative gas absorbed by canister.		

INTAKE (INDUCTION) ***IN*** (***TURBO***)

	Page
1. Intake System	
2. Turbocharger System	2

TURBOCHARGER SYSTEM

Intake (Induction)

2. Turbocharger System

I: INTERCOOLER WATER SPRAY

- Water is sprayed from the nozzle in the intercooler duct to cool down the intercooler with water spray when the intake air temperature becomes high so that the air temperature is lowered and air intake efficiency is increased.
- The water tank is located in the trunk. The spray nozzle is a diffusion type which ensure a high cooling efficiency.

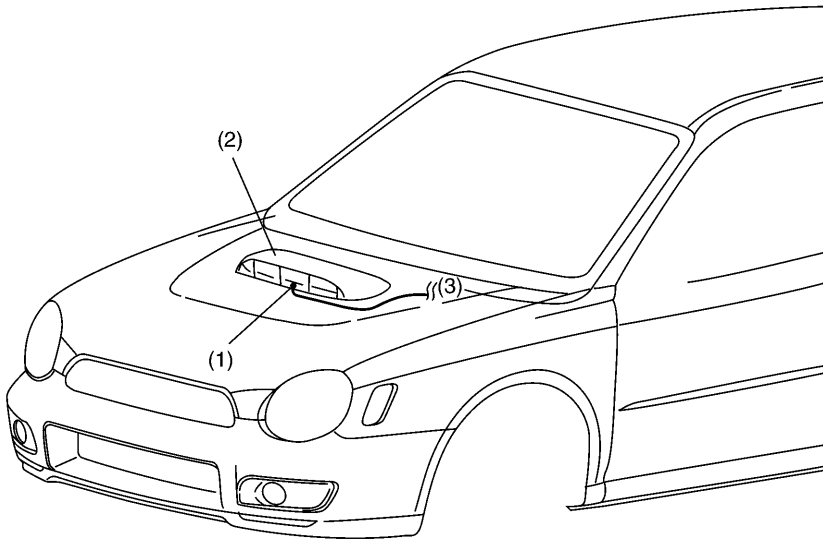

NF0624

- (1) Spray nozzle
- (2) Intercooler duct
- (3) To water tank

MECHANICAL *ME* (TURBO)

	Page
1. General	
2. Timing Belt	
3. Automatic Belt Tension Adjuster	
4. Belt Cover	
5. Camshaft	2
6. Cylinder Head	3
7. Cylinder Block	4
8. Crankshaft	
9. Piston	5
10. Engine Mounting	
11. Variable Valve Timing System	6
12. Sodium-filled Exhaust Valves	9

CAMSHAFT

Mechanical

5. Camshaft

The DOHC engine uses four camshafts in all; intake and exhaust camshafts on each of the right and left banks.

The cam lobe noses are finished by “chill” treatment to increase wear resistance and anti-scuffing properties.

Each camshaft is supported at its three journals and held in position by three camshaft caps. Each camshaft has a flange which fits in the corresponding groove in the cylinder head to receive thrust forces generated in the camshaft.

With the engine for the STi model, each intake camshaft has teeth at the rear end for the variable valve timing position sensor.

B: STi MODEL

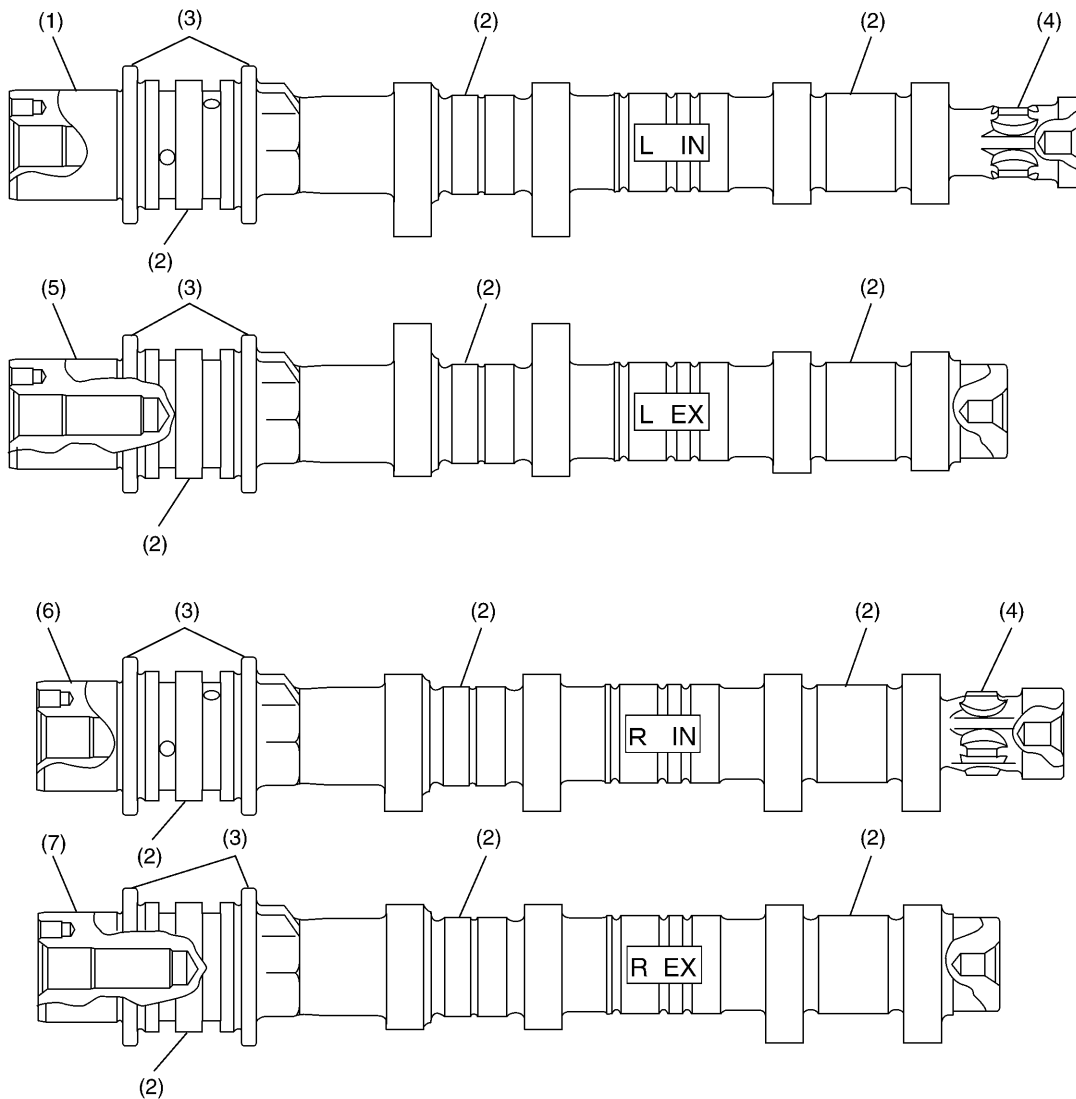

NF0625

(1) Left intake camshaft

(2) Journal

(3) Flange

(4) Teeth for variable timing position sensor

(5) Left exhaust camshaft

(6) Right intake camshaft

(7) Right exhaust camshaft

6. Cylinder Head

- The cylinder head is made of aluminium die casting.
- Each combustion chamber in the cylinder head is a compact, pentroof design. The spark plug is located at the center of the combustion chamber, which contributes to creation of a wide “squish area” for increased combustion efficiency.
- The two intake and two exhaust valves are arranged on opposite sides for a cross-flow feature.
- The cylinder head gasket is a metallic gasket consisting of three layers of the stainless steel sheets. It is highly resistant to heat and maintains high level of sealing performance for a long period.

B: STi MODEL

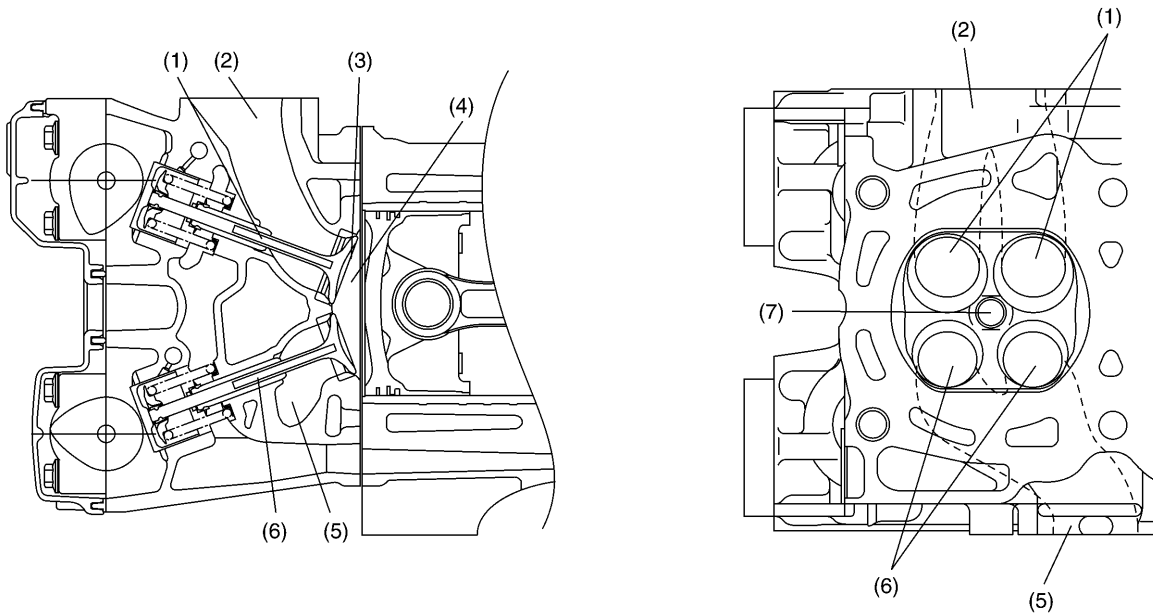

- (1) Intake valve (hollow type)
- (2) Intake port
- (3) Squish area
- (4) Combustion chamber

- (5) Exhaust port
- (6) Exhaust valve (Sodium-filled)
- (7) Spark plug

NF0626

7. Cylinder Block

- With all the engines except that for the STi model, the cylinder block is made of aluminum die casting. Its open-deck design provides it with such advantageous features as relatively small weight, high rigidity and excellent cooling efficiency.
- With the engine for the STi model that generates increased torque outputs, the cylinder block uses a semi-closed deck design which can hold the cylinder liners with higher rigidity.
- The cylinder liners are made of cast iron. They are dry type which means their outer surfaces are entirely in contact with the cylinder block.
- The cylinder block supports the crankshaft at its five journals. The journal supporting portions are designed such that sufficient stiffness and quiet operation are ensured.
- The oil pump is located in the front center of the cylinder block and the engine coolant pump is located at the front of the left-cylinder bank. At the rear of the right-cylinder bank is an oil separator which removes oil mist contained in blow-by gas.

9. Piston

- The pistons are of a slipper skirt design for reduced weight and friction. The oil control ring groove utilizes a thermal design.
- The piston pin is offset either downward (Nos. 1 and 3 pistons) or upward (Nos. 2 and 4 pistons).
- The piston head has recesses to prevent interference with the intake and exhaust valves. It also has engraved marks to identify the piston size and the direction of installation. All the pistons are common in their design.
- Three piston rings are used for each piston – two compression rings and one oil control ring. The top piston ring has inner bevel and the second piston ring has a cut on the bottom outside to reduce oil consumption.

B: STi MODEL

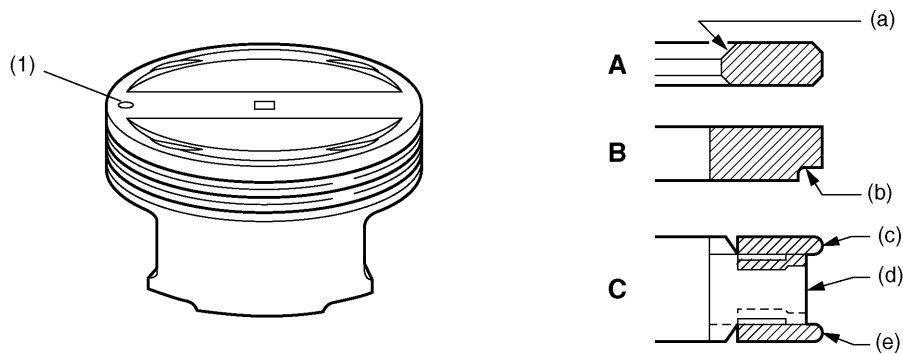

(1) Location mark (Engine front side)

- | | |
|-----------------------|-----------------|
| A: Top ring | (a) Inner-bevel |
| B: Second ring | (b) Cut |
| C: Oil ring | (c) Upper rail |
| | (d) Spacer |
| | (e) Lower rail |

NF0580

VARIABLE VALVE TIMING SYSTEM

Mechanical

11. Variable Valve Timing System

The STi model's engine has the variable valve timing system, which adjusts the opening and closing timings of the intake valves optimally by continuously changing the phase angle of the camshaft sprocket relative to the camshaft.

- The ECM determines the optimal cam angle relative to the crank angle by making reference to the engine speed, vehicle speed, throttle opening and other relevant parameters.
- Under the control of the ECM, the oil flow control valve moves its spool to switch the hydraulic passage to/from the advance and retard chambers that are formed in the camshaft sprocket to change continuously the phase angle between the camshaft sprocket and camshaft.

A: PHASE ANGLE ADVANCES

In response to an advance signal from the ECM, the oil flow control valve moves its spool such that hydraulic pressure is applied to the advance chamber in the camshaft sprocket. The sprocket is then turned in the direction in which its phase angle advances relative to the camshaft.

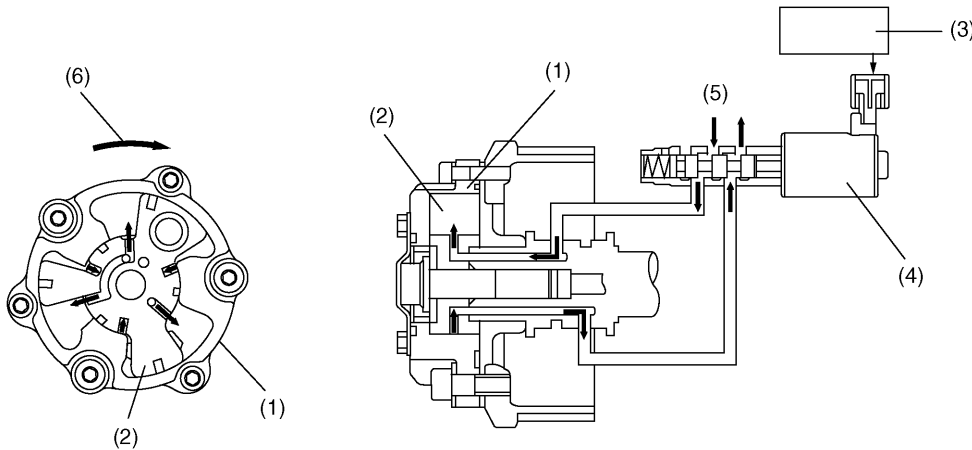

NF0581

- (1) Variable valve timing controller (attached to camshaft sprocket)
- (2) Vane (attached to intake camshaft)
- (3) ECM
- (4) Oil flow control valve
- (5) Hydraulic pressure
- (6) Turns in advance direction

B: PHASE ANGLE RETARDS

In response to a retard signal from the ECM, the oil flow control valve moves its spool such that hydraulic pressure is applied to the retard chamber in the camshaft sprocket. The sprocket is then turned in the direction in which its phase angle retards relative to the camshaft.

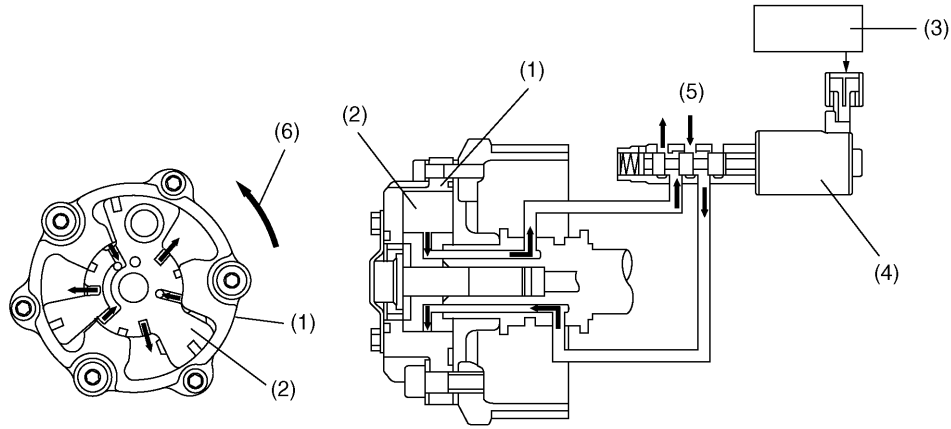

NF0582

- (1) Variable valve timing controller (attached to camshaft sprocket)
- (2) Vane (attached to intake camshaft)
- (3) ECM
- (4) Oil flow control valve
- (5) Hydraulic pressure
- (6) Turns in retard direction

VARIABLE VALVE TIMING SYSTEM

Mechanical

C: A CERTAIN PHASE ANGLE IS RETAINED

When the ECM issues a signal to keep the phase angle unchanged, the oil flow control valve moves its spool to the position at which the hydraulic pressures to/from both the chambers are blocked. The pressures in the chambers are thus maintained, so the phase angle does not change and the intake valves' opening and closing timings also remain unchanged.

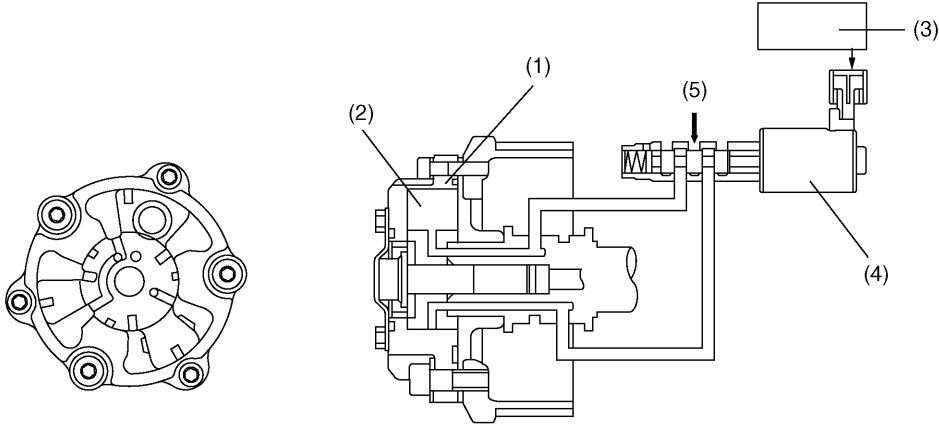

NF0583

- (1) Variable valve timing controller (attached to camshaft sprocket)
- (2) Vane (attached to intake camshaft)
- (3) ECM
- (4) Oil flow control valve
- (5) Hydraulic pressure

12. Sodium-filled Exhaust Valves

The STi model's engine uses sodium-filled exhaust valves. Each exhaust valve contains pure sodium in its hollow stem. Sodium has high thermal conductivity. The entrapped sodium will liquefy at high temperatures and move inside the stem as the valve is operated. Thus the sodium will effectively transfer heat from the valve head to the valve stem, contributing to cooling down the valve head faster.

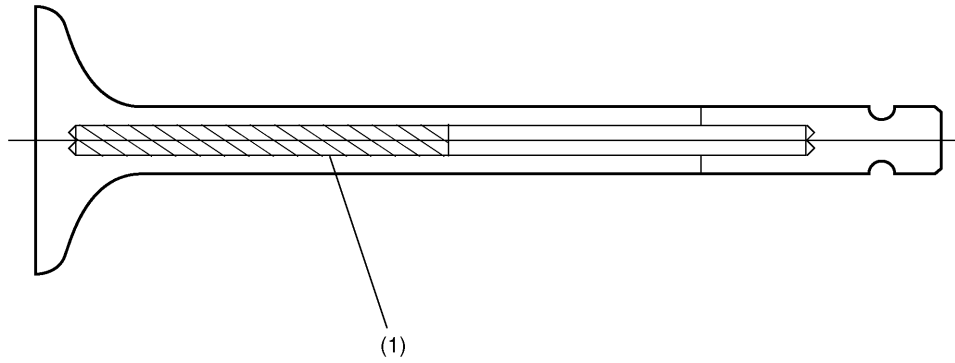

(1) Pure sodium

B2H4814A

SODIUM-FILLED EXHAUST VALVES

Mechanical

MEMO

CONTROL SYSTEM

CS

Page

1. Gear Shift Lever	
2. Select Lever	
3. Dual Range Selector Lever	
4. 6MT Gear Shift lever	2

6MT GEAR SHIFT LEVER

4. 6MT Gear Shift Lever

A: GENERAL

The six-speed manual transmission's control system has a gear shift lever specially designed for the use with it. The gearshift lever is complete with a parallel-link gear shift mechanism as is the case with the five-speed transmission's gearshift lever. To prevent accidental engagement of the reverse gear, the lever has an arrangement that allows a shift into reverse only after the slider has been pulled up.

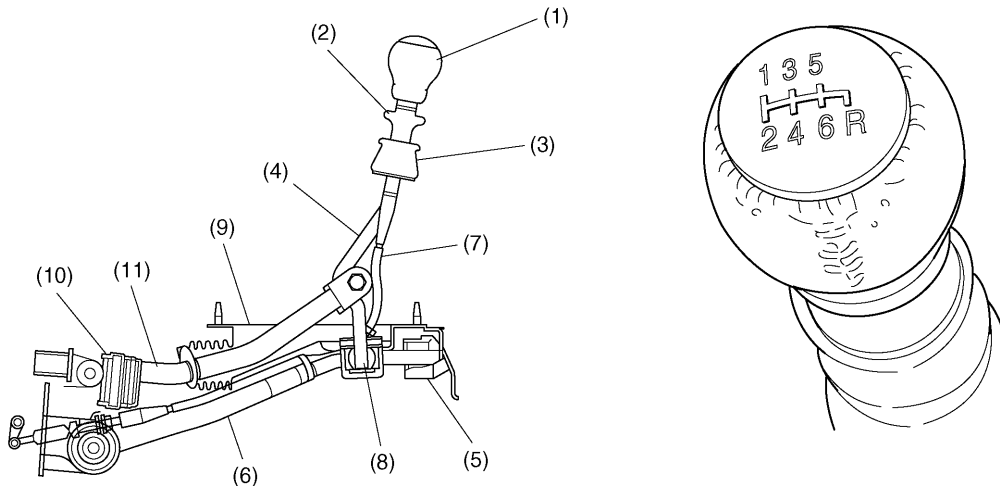

NF0596

- | | | |
|------------|-------------------------|------------|
| (1) Knob | (5) Cushion rubber | (9) Boot |
| (2) Slider | (6) Stay | (10) Joint |
| (3) Holder | (7) Reverse check cable | (11) Rod |
| (4) Lever | (8) Bush | |

B: OPERATION

When shifting gear into reverse, the driver pulls the slider up (toward the knob). This causes the reverse check cable to move the reverse lever on the six-speed transmission to the lock release position. Since the reverse check system in the transmission then becomes in the state ready for a shift into reverse, the driver can move the gear shift lever to the reverse position.

Should the reverse check cable be severed, the spring in the holder pushes up the slider and keeps it in the raised position, alerting the driver to the abnormality. Since the reverse check system does not function under this condition, a voluntary or involuntary shift can take place without any restriction.

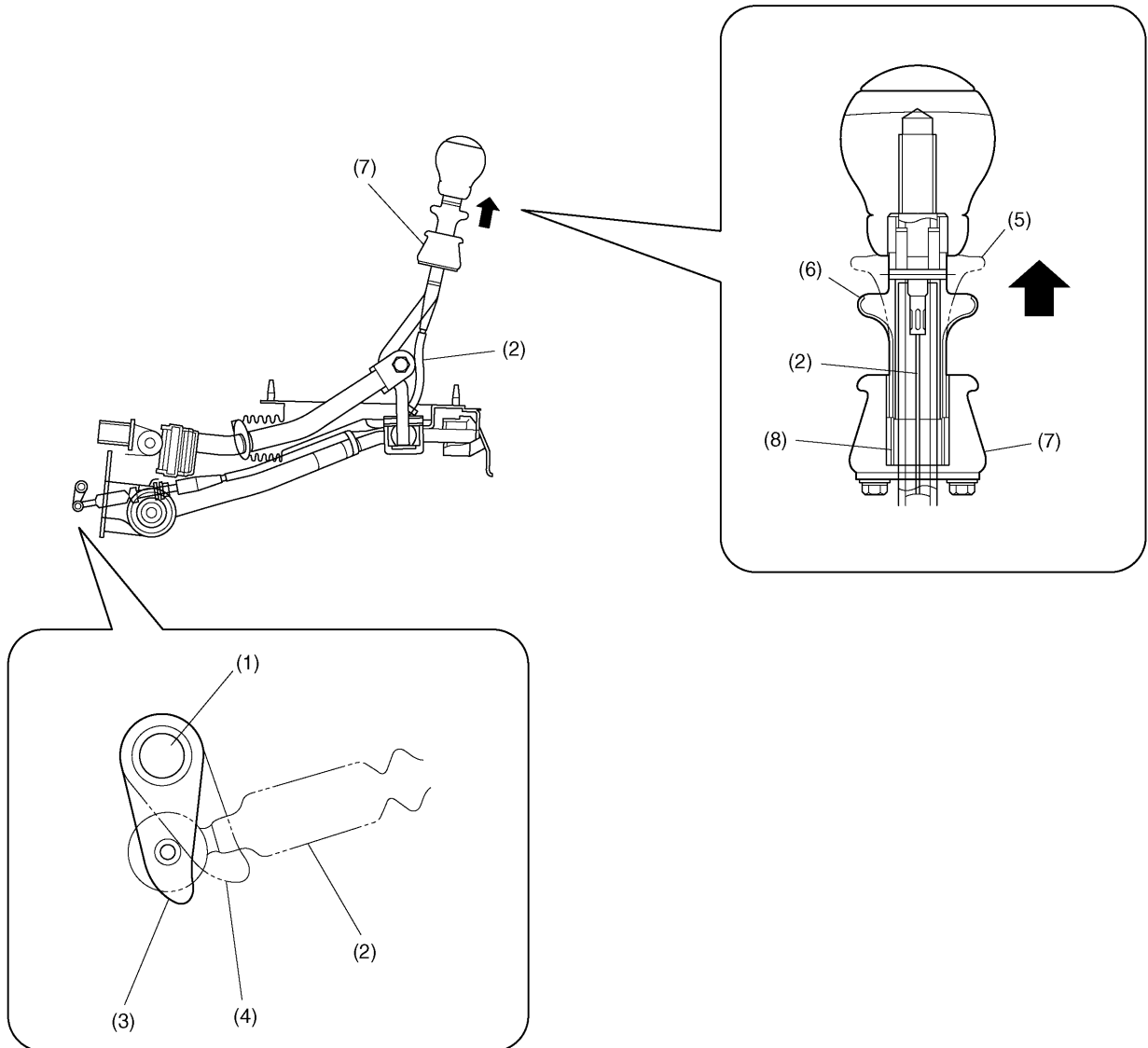

NF0597

- | | |
|--|--|
| (1) Reverse lever | (5) Slider (in reverse select lock release position or when cable is broken) |
| (2) Reverse check cable | (6) Slider (in reverse select lock position) |
| (3) Reverse select lock position | (7) Holder |
| (4) Reverse select lock release position | (8) Spring |

6MT GEAR SHIFT LEVER

Control System

MEMO

MANUAL TRANSMISSION AND DIFFERENTIAL

6MT

	Page
1. General	2
2. Triple-Cone Synchronizer	4
3. Reverse Idler Gear Assembly (with Synchronizing Mechanism)	5
4. Shift and Select Mechanism	7
5. Reverse Check Mechanism	12
6. Center Differential	16
7. Oil Pump	22
8. Lubrication System	23
9. Front Differential (SURETRAC Type Limited Slip Differential)	24
10. Transmission Mounting	29

1. General

The six-speed manual transmission has been newly developed to exploit the full potential of the STi model's engine and enable the model to have a surpassing driving performance.

The major features of this new transmission are as follows:

- The driver can make a gear shift with a smaller force than with conventional transmissions owing to the double-cone synchronizers employed for the 1st, 3rd and reverse gears and the triple-cone synchronizer employed for the 2nd gear. In addition, the synchronizing elements of the 2nd to 6th gears have splines with asymmetric chamfers in order to prevent generation of undesirable loads that would cause simultaneous engagement of two gears ("double meshing") as well as to ensure improved gear shift feeling.
- The reverse idler gear is a constant-mesh type with a new subgear.
- The shift/select mechanism is of a parallel link design. It has shift rods each supported by a slidable ball bearing and provided with a detent mechanism that uses a plunger with a ball inside.
- The reverse check mechanism prevents unintended engagement of the reverse gear when the driver makes a shift into the 5th or 6th gear.
- The transmission case is split into three pieces lateral direction like that of the automatic transmission used in the standard model. It is highly rigid owing to appropriately arranged ribs.
- The oil pump incorporated in the transmission case ensures improved lubricating and cooling performance.
- An optional SURETRAC type limited slip differential has been introduced for the front differential.
- The center differential uses a viscous coupling of the type whose high performance has already been proven with the preceding SUBARU models.

GENERAL

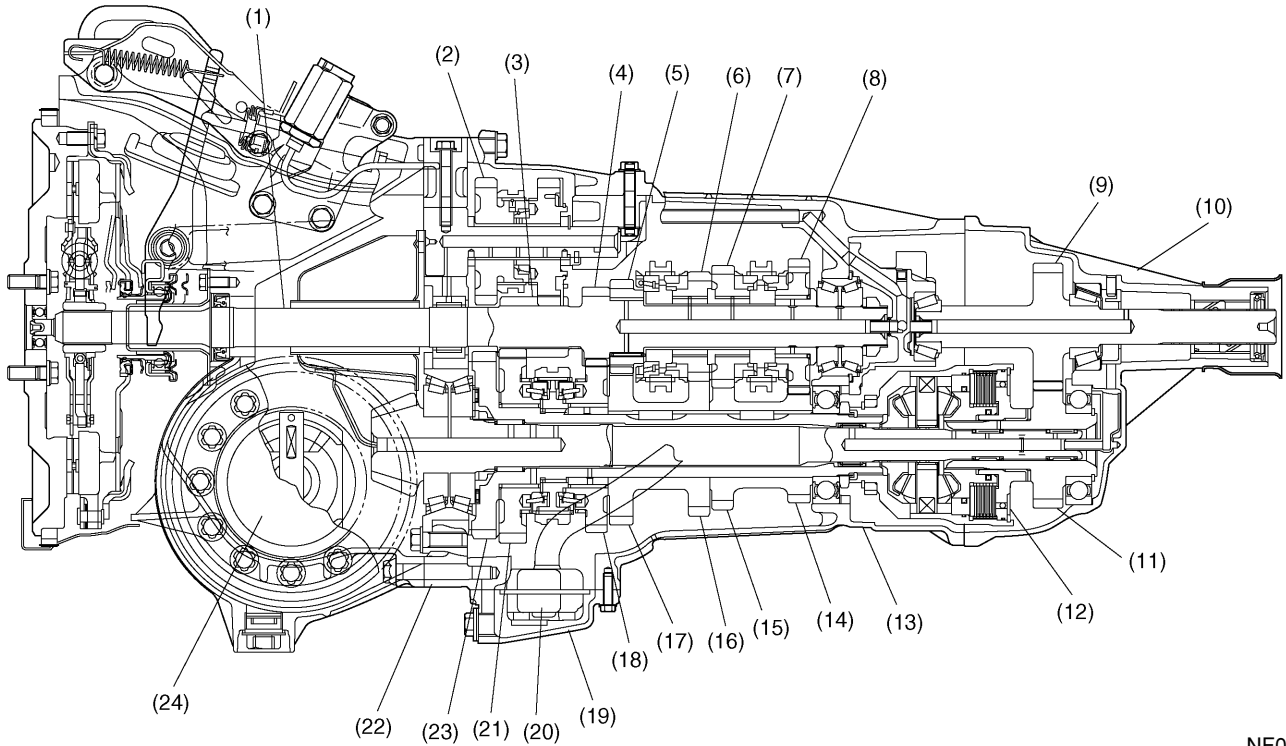

NF0598

- | | | |
|------------------------|-----------------------------------|----------------------------------|
| (1) Main shaft | (9) Transfer driven gear | (17) 3rd driven gear |
| (2) Reverse idler gear | (10) Extension case | (18) 2nd driven gear |
| (3) 1st drive gear | (11) Transfer drive gear | (19) Oil pan |
| (4) 2nd drive gear | (12) Center differential assembly | (20) Oil strainer |
| (5) 3rd drive gear | (13) Transmission case | (21) 1st drive gear |
| (6) 4th drive gear | (14) 6th driven gear | (22) Adapter plate |
| (7) 5th drive gear | (15) 5th driven gear | (23) Reverse driven gear |
| (8) 6th drive gear | (16) 4th driven gear | (24) Front differential assembly |

TRIPLE-CONE SYNCHRONIZER

2. Triple-Cone Synchronizer

A: CONSTRUCTION

The triple-cone synchronizer has three frictional interfaces - in addition to the two coaxial interfaces between the synchronizer cone and the inner and outer balk rings (which are same as those with a double-cone synchronizer), it has a third frictional interface between the inner surface of the inner balk ring and the cone on the 2nd driven gear. Thanks to an increased friction force, the triple-cone type produces larger synchronizing power than a double-cone type synchronizer. The main components of the triple-cone synchronizer are the outer balk ring, synchronizer cone, inner balk ring, and 2nd driven gear's cone.

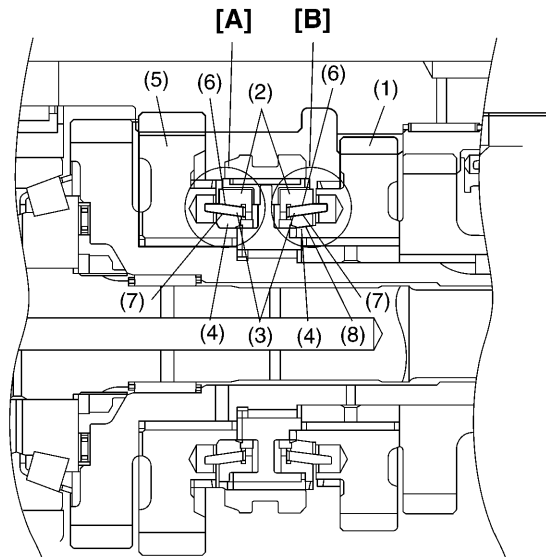

NF0599

[A] Double-cone synchronizer

[B] Triple-cone synchronizer

(1) 2nd driven gear

(2) Outer balk ring

(3) Synchronizer cone

(4) Inner balk ring

(5) 1st driven gear

(6) Cone surface 1

(7) Cone surface 2

(8) Cone surface 3

3. Reverse Idler Gear Assembly (with Synchronizing Mechanism)

- A constant-mesh type reverse gearing is used in the six-speed manual transmission.
- The reverse idler gear assembly is provided with a double-cone synchronizer.

Soon after disengagement of the clutch, the reverse gear remains rotating by an inertial force. If the driver makes a shift while the reverse gear is still rotating, an undesirable “gear clash” would occur. The double-cone synchronizer prevents this by synchronizing the speed of the No. 2 reverse idler gear with that of the reverse sleeve. It also allows the driver to make a smooth shift into the reverse gear.

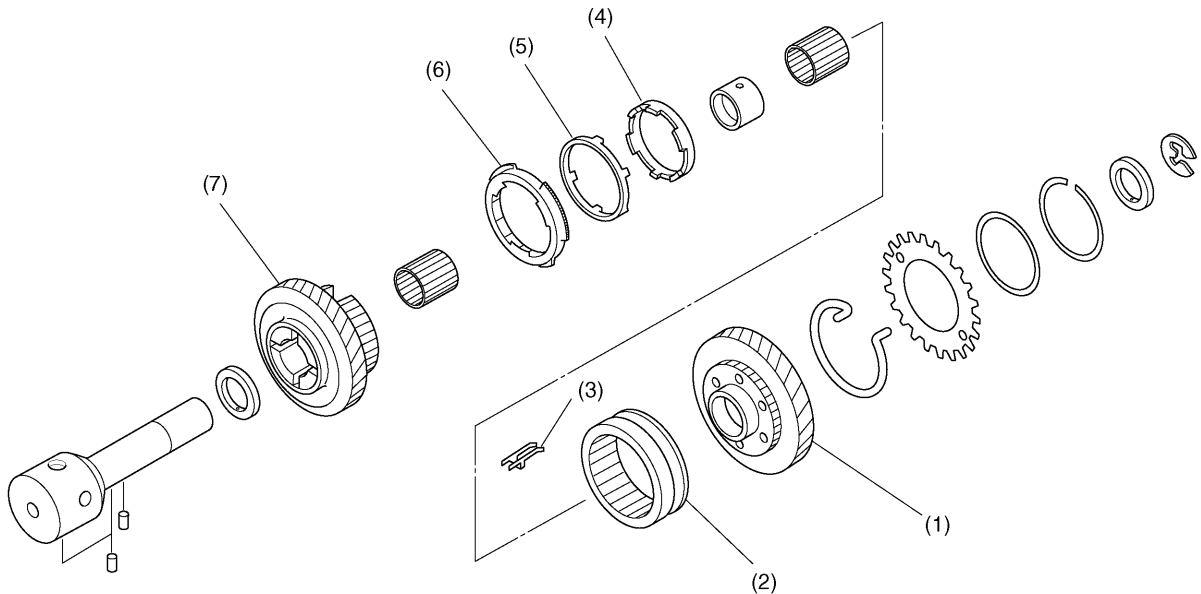

- (1) No. 1 reverse idler gear
- (2) Reverse sleeve
- (3) Insert key

- (4) Inner balk ring
- (5) Synchronizer cone
- (6) Outer balk ring

- (7) No. 2 reverse idler gear

NF0600

REVERSE IDLER GEAR ASSEMBLY (WITH SYNCHRONIZING MECHANISM)

Manual Transmission and Differential

● To prevent rattling noise that may occur with the constant-mesh type reverse gearing, No.1 reverse idler gear is fitted with a subgear that has the same number of teeth as the No. 1 reverse idler gear. The subgear is preloaded in the rotating direction by a spring so that it functions to reduce backlash between gear teeth and consequent rattling noise when the No. 1 reverse gear meshes with the reverse drive gear.

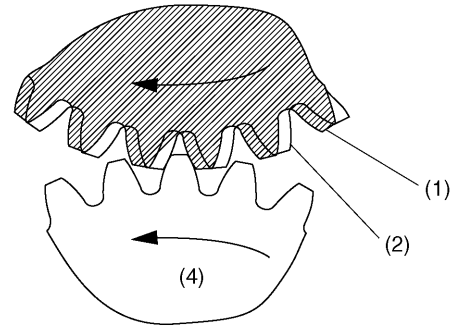
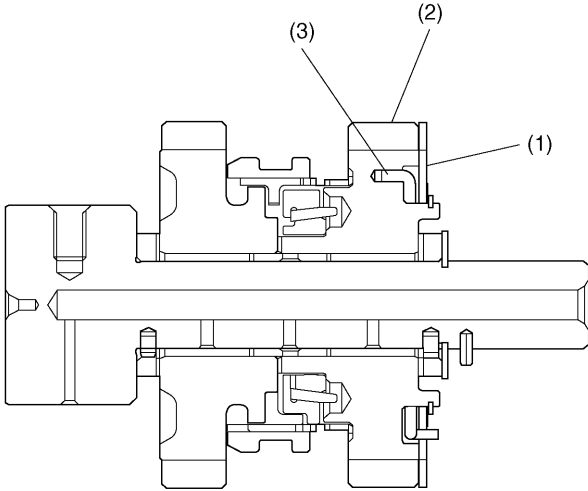

NF0601

- (1) Subgear
- (2) No. 1 reverse idler gear

- (3) Spring
- (4) Reverse drive gear

SHIFT AND SELECT MECHANISM

4. Shift and Select Mechanism

- Each of the shifter and fork rods has a detent mechanism using a plunger with a ball in it and is supported with a slidable ball bearing. The detent mechanisms give the driver distinctive detent feeling and the slidable ball bearings help reduce the shift lever operating force.
- Gear double meshing is prevented by a mechanism that uses interlock blocks.
- The select return mechanism (which returns the selector lever to the neutral position) uses a U-shaped leaf spring.

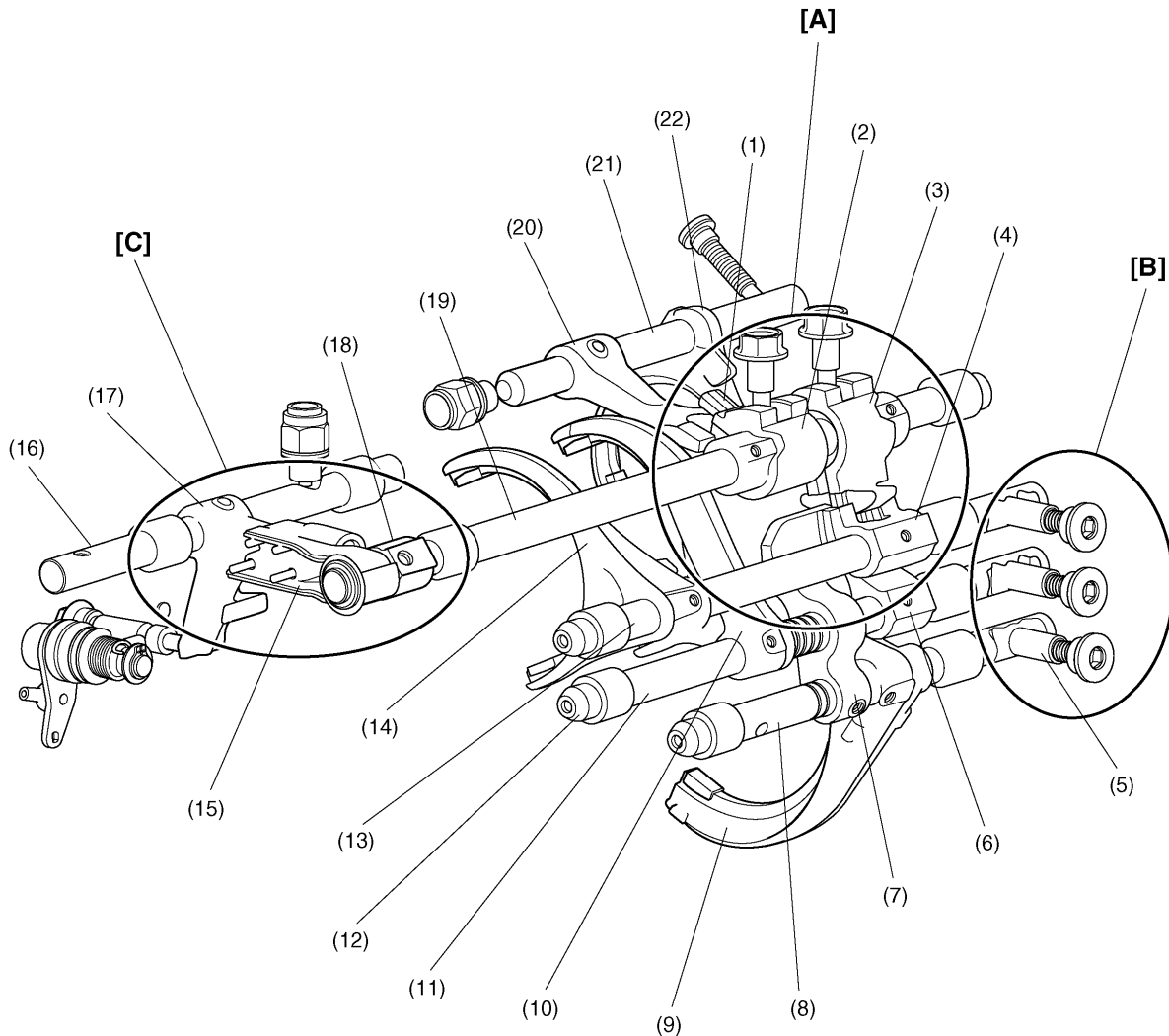

NF0602

- | | | |
|-----------------------------|--------------------------|---------------------------|
| [A] Interlock mechanism | (6) 3rd-4th shifter arm | (15) Neutral set spring |
| [B] Shift detent mechanism | (7) 1st-2nd shifter arm | (16) Shifter arm shaft |
| [C] Select return mechanism | (8) 1st-2nd shifter rod | (17) No. 1 selector arm |
| (1) Interlock arm | (9) 1st-2nd shift fork | (18) No. 2 selector arm |
| (2) Reverse interlock block | (10) 3rd-4th shift fork | (19) Striking rod |
| (3) Interlock block | (11) 3rd-4th shifter rod | (20) Reverse shifter arm |
| (4) 5th-6th shifter arm | (12) Slidable bearing | (21) Reverse fork rod |
| (5) Shifter plunger | (13) 5th-6th fork rod | (22) Reverse shifter fork |
| | (14) 5th-6th shift fork | |

SHIFT AND SELECT MECHANISM

Manual Transmission and Differential

A: MECHANISMS

1. SHIFT DETENT MECHANISM

The shift detent mechanism allows the driver to distinctively feel the shift into a gear. The mechanism also prevents the transmission from jumping out of gear.

The shift detent mechanism uses a plunger with a check ball in it. The check ball is held under a small bowl which has the function of reducing friction during a shift and with the detent mechanism on the fork rod, generating a force to retain a gear in the selected position.

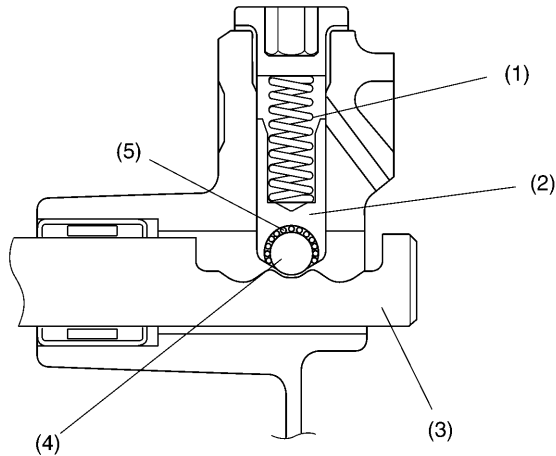

NF0603

- (1) Spring
- (2) Plunger
- (3) Fork rod

- (4) Check ball
- (5) Bowl

SHIFT AND SELECT MECHANISM

2. SELECT RETURN MECHANISM

The select return mechanism allows the shift lever to return to the neutral position. The neutral set spring pinches between its two arms the four pins on the No. 1 selector arm to hold the shift lever always in the neutral position. When the driver moves the shift lever in a select direction, the No. 1 and No. 2 selector arms turn about their axes, changing their relative angle. This causes a pair of diagonally opposing pins on the No. 1 selector arm to open the neutral set spring. When the driver then releases the shift lever, the opened neutral set spring pushes by its returning force the pins to bring the selector arms back to the neutral position.

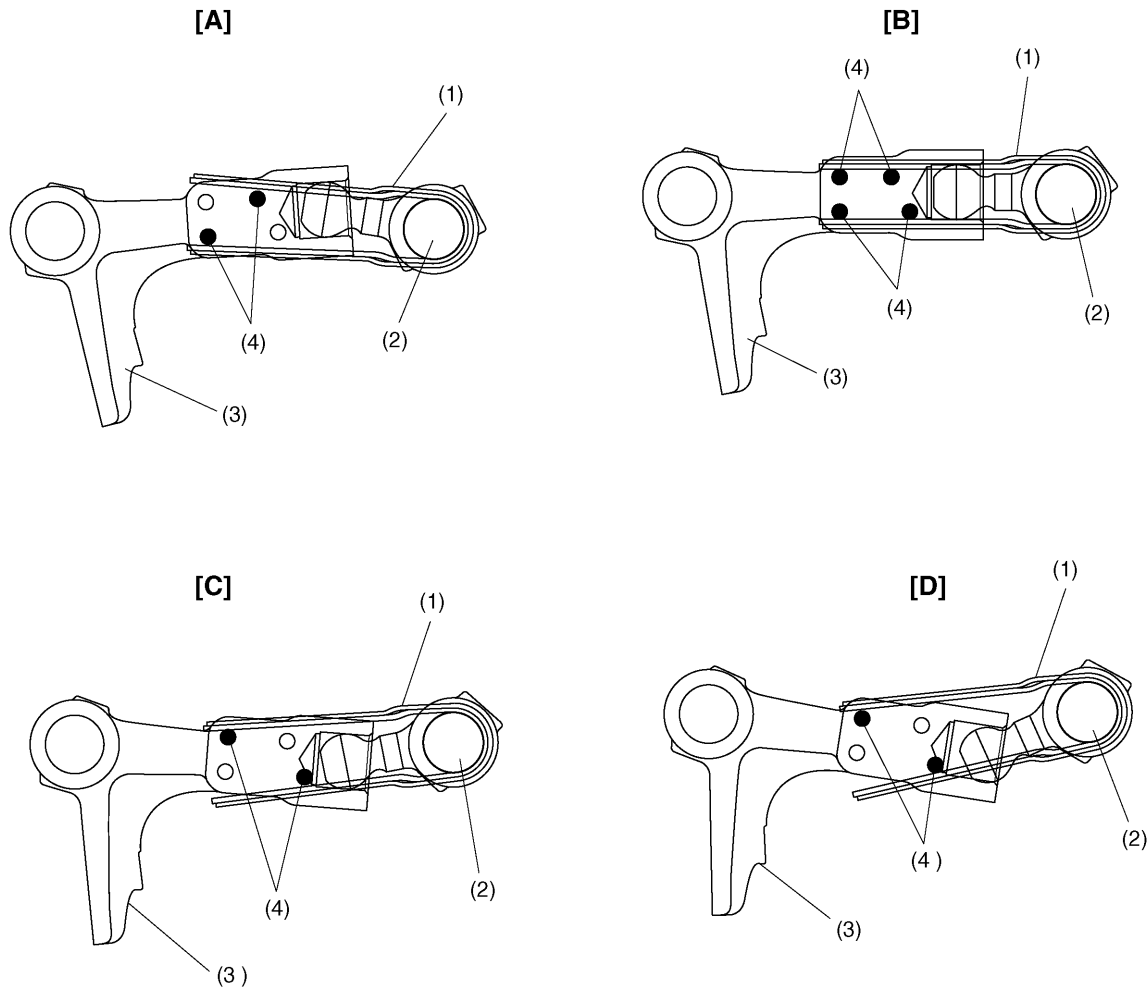

- (1) Neutral set spring
- (2) No. 2 selector arm
- (3) No. 1 selector arm
- (4) Pin

- [A] 1st-2nd
- [B] Neutral/3rd-4th
- [C] 5th-6th
- [D] Reverse

NF0604

SHIFT AND SELECT MECHANISM

3. INTERLOCK MECHANISM (DOUBLE-MESHING PREVENTION MECHANISM)

The interlock mechanism makes it impossible to shift the transmission into two gears at once. When the interlock arm selects the shifter arm corresponding to the gear into which the driver is going to make a shift, the interlock blocks also move in the same select direction, preventing the other shifter arms from being selected.

The gap between the two blocks is adjusted such that only one shifter arm can enter it, so the interlock blocks prevent the other two shifter arms from being selected even if the driver operates the shift lever in a way that otherwise would cause simultaneous engagement of two gears.

- **When shift lever is properly operated**

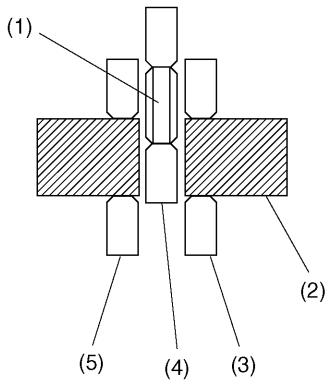

- (1) Interlock arm
- (2) Interlock block
- (3) 5th-6th shifter arm

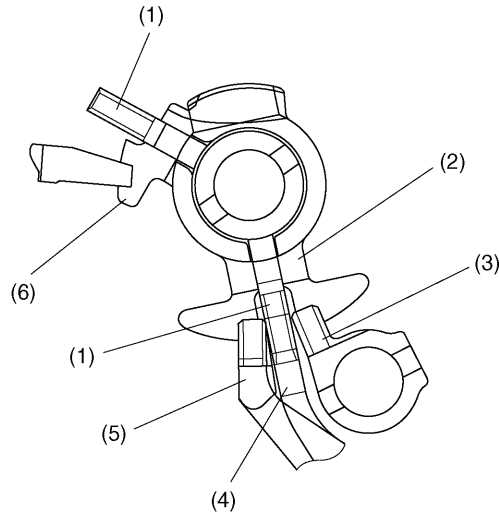

- (4) 3rd-4th shifter arm
- (5) 1st-2nd shifter arm
- (6) Reverse interlock block

NF0605

SHIFT AND SELECT MECHANISM

• When “double meshing” is prevented

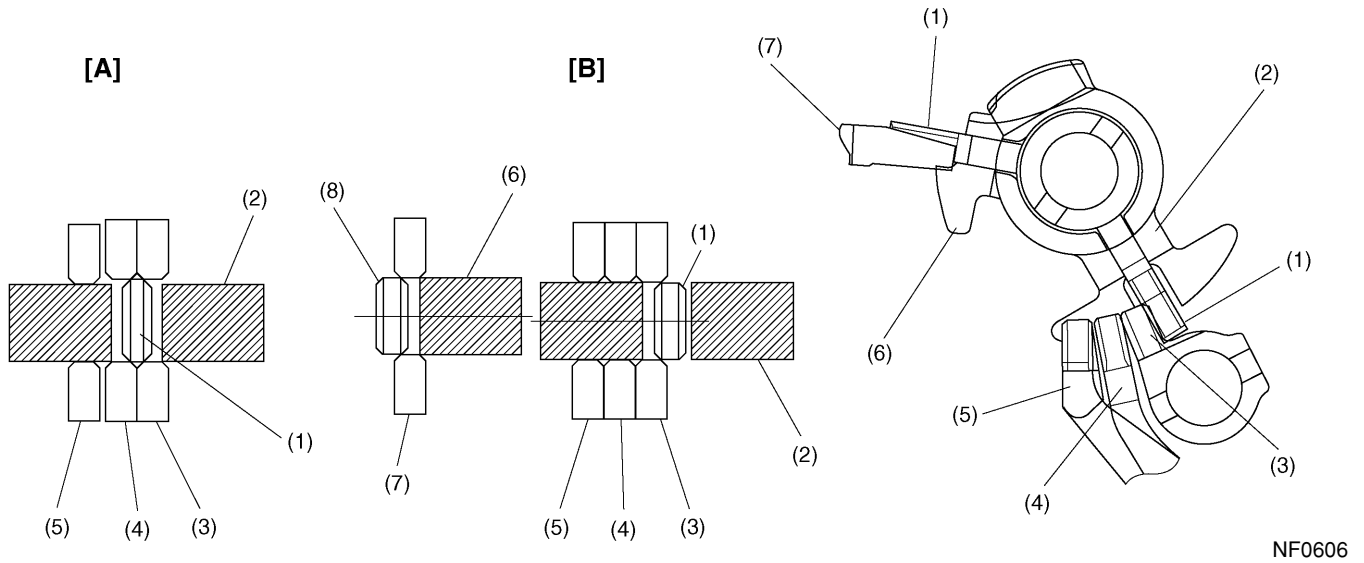

NF0606

[A] Preventing 3rd and 5th double meshing

- (1) Interlock arm
- (2) Interlock block
- (3) 5th-6th shifter arm
- (4) 3rd-4th shifter arm

[B] Preventing 6th and reverse double meshing

- (5) 1st-2nd shifter arm
- (6) Reverse interlock block
- (7) Reverse shifter arm
- (8) Reverse interlock block

REVERSE CHECK MECHANISM

5. Reverse Check Mechanism

The reverse check mechanism prevent the reverse gear from being accidentally engaged when the driver makes a shift into the 5th or 6th gear. This mechanism is provided with a fail-safe function which enable shifting into reverse if the reverse check cable should be broken.

A: CONSTRUCTION

The reverse check mechanism is located inside the extension case. It consists of a reverse check lever, oil seal, bearing, reverse check shaft, spring, plug and reverse check plug.

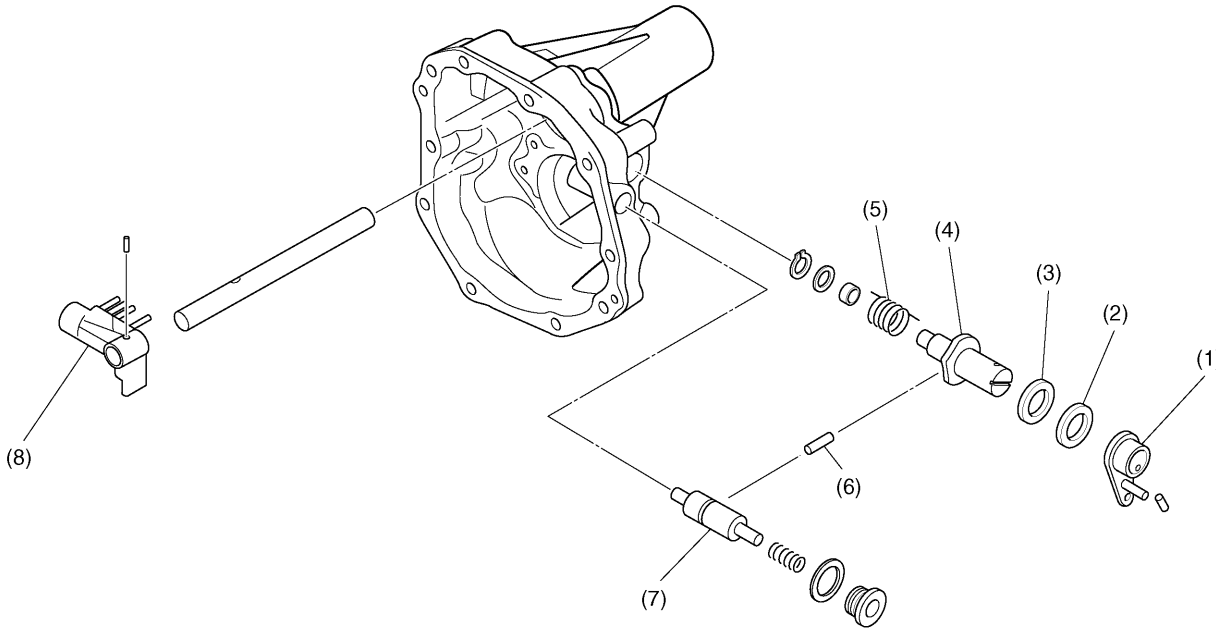

NF0607

- (1) Reverse check lever
- (2) Oil seal
- (3) Bearing
- (4) Reverse check shaft

- (5) Spring
- (6) Plug
- (7) Reverse check plug
- (8) No. 1 selector arm

REVERSE CHECK MECHANISM

B: OPERATION

1. MAKING SHIFT INTO 5TH/6TH

When the shift lever is moved into the 5th or 6th position, the No. 1 selector arm comes into contact with the reverse check plunger, trying to move the reverse check plug.

However, one end of the plunger is in contact with the cam lobe on the reverse check shaft and the other end is held in the groove in the reverse check plug, so the selector arm cannot move in the reverse gear selecting direction.

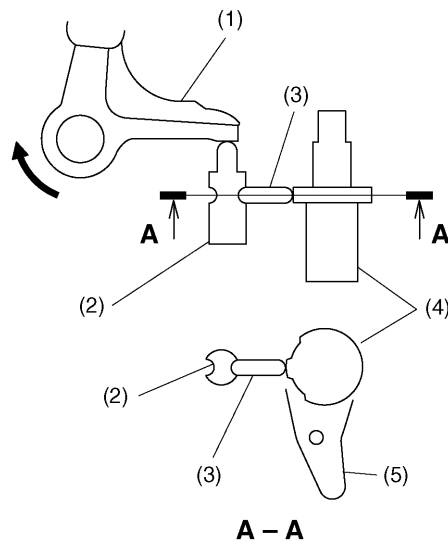

- (1) No. 1 selector arm
- (2) Reverse check plug
- (3) Plunger

- (4) Reverse check shaft
- (5) Reverse check lever

NF0608

REVERSE CHECK MECHANISM

2. MAKING SHIFT INTO REVERSE

When making a shift into reverse, the driver lifts the slider on the shift lever. The upward movement of the slider causes, via the reverse check cable, the reverse check shaft to turn such that the cam lobe on the reverse check shaft becomes clear of the plunger.

The plunger can now move toward the reverse check shaft, allowing the selector arm to turn in the reverse gear selecting direction.

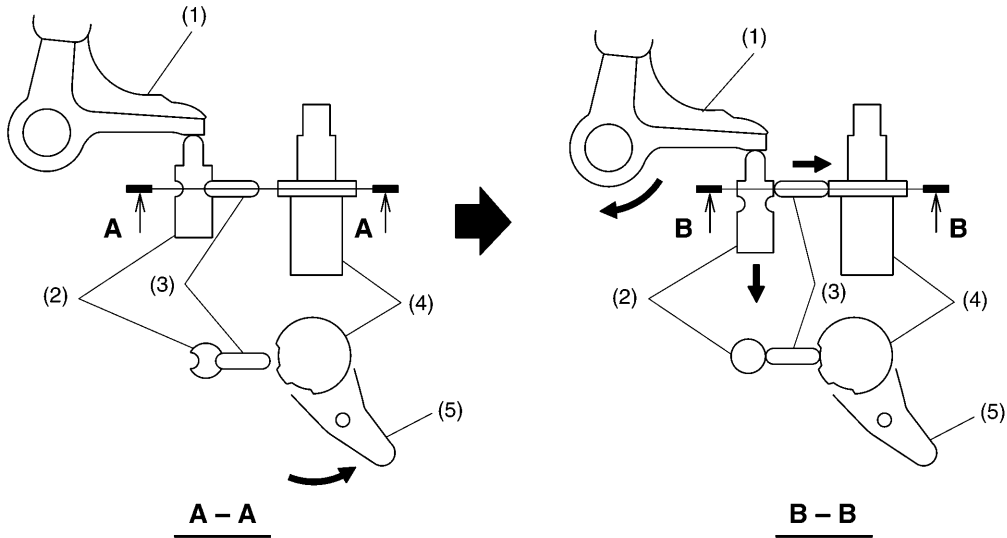

NF0609

- (1) Selector arm
- (2) Reverse check plug
- (3) Plunger

- (4) Reverse check shaft
- (5) Reverse check lever

REVERSE CHECK MECHANISM

3. FAIL-SAFE OPERATION

Should the reverse check cable be broken, the reverse check shaft turns counterclockwise by a spring force, making the plunger get clear of the cam lobe of the reverse check shaft.

The plunger can now move toward the reverse check shaft, allowing the selector arm to turn in the reverse selecting direction.

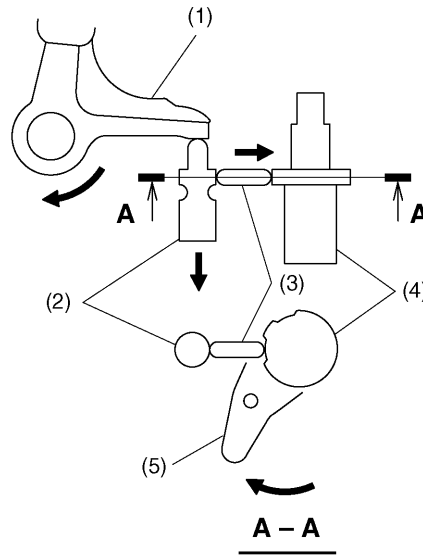

- | | |
|------------------------|-------------------------|
| (1) Selector arm | (4) Reverse check shaft |
| (2) Reverse check plug | (5) Reverse check lever |
| (3) Plunger | |

NF0610

CENTER DIFFERENTIAL

6. Center Differential

A: CONSTRUCTION

The center differential consists of a set of bevel gears and a viscous coupling.

The center differential has the following two functions: distributing the engine torque to the front and rear wheel drive shafts and absorbing the difference in rotating speed between the front and rear wheels.

The engine torque enters the center differential case from the transmission's driven shaft. The torque is then distributed through the bevel gear set directly to the drive pinion shaft and via the transfer drive and driven gears to the rear drive shaft.

The viscous coupling limits the bevel gear set's differential action when either front or rear wheels spin so that adequate torques are transmitted to the front and rear wheels and proper traction is obtained.

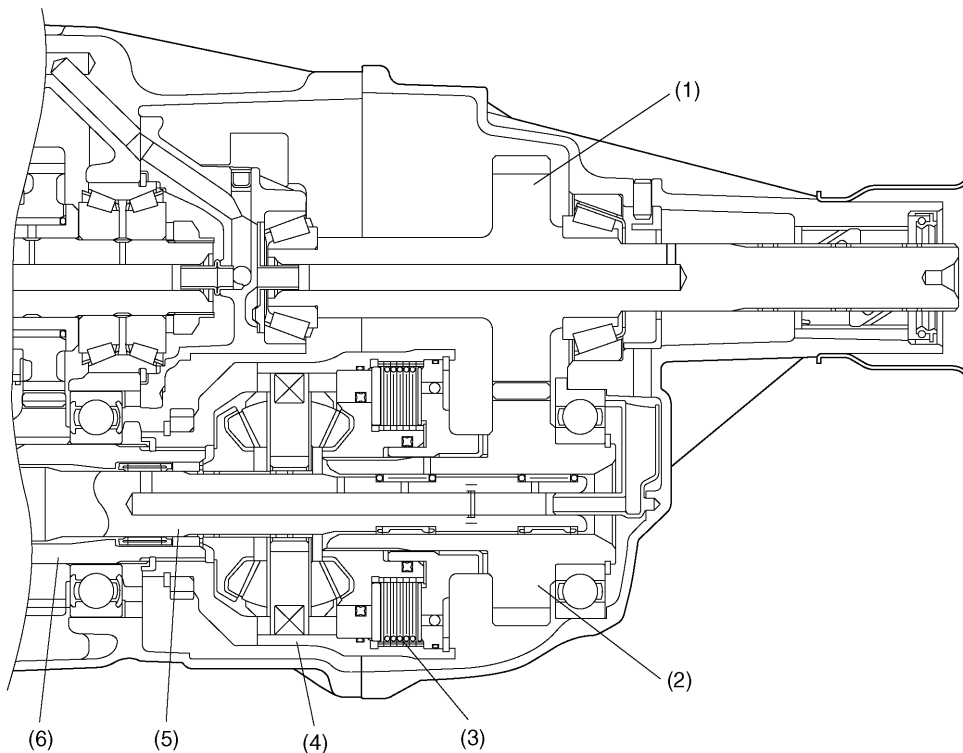

NF0611

- | | |
|--------------------------|--|
| (1) Transfer driven gear | (4) Center differential assembly (with viscous coupling) |
| (2) Transfer drive gear | (5) Drive pinion shaft |
| (3) Viscous coupling | (6) Driven shaft |

B: MECHANISM OF VISCOUS COUPLING

The viscous coupling consists of a number of alternately arranged inner and outer plates and air-and-silicone oil mixture filled into a sealed space that is formed by the center differential case and the rear side gear of the differential gear set. The inner plates have their inner perimeters splined to the side gear and the outer plates have their outer perimeters splined to the center differential case. The outer plates are held apart by spacer rings. There are no spacer rings between the inner rings, so the inner rings are movable slightly in axial directions. X-section rings are used to prevent leakage of silicone oil which would otherwise occur if the oil is pressurized due to large difference in front and rear axle speeds.

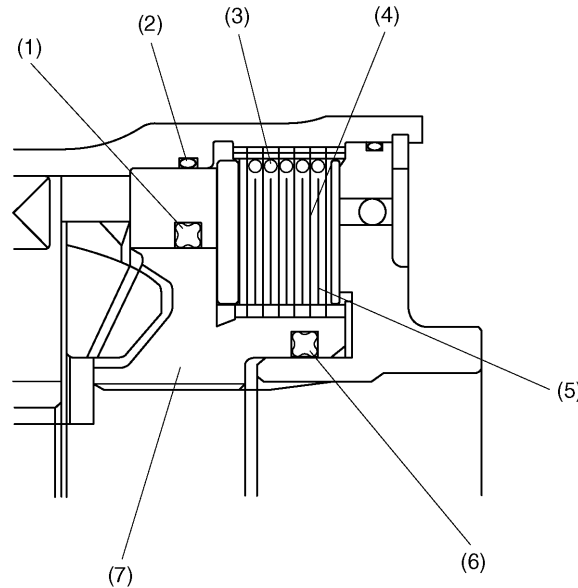

- (1) X-section ring
- (2) O-ring
- (3) Spacer ring
- (4) Outer plate

- (5) Inner plate
- (6) X-section ring
- (7) Side gear (rear)

NF0612

CENTER DIFFERENTIAL

1. TORQUE CHARACTERISTICS

When a speed difference occurs between the center differential case and the rear side gear, a shear force is generated in the silicone oil placed between the outer and inner plates. The torque is then transmitted by the silicone oil between the center differential case and the rear side gear.

The greater the speed difference, the greater the shear force generated in the silicone oil. The relationship between the torque transmission and the speed difference is shown in the figure below. As can be seen from the figure, the smaller the speed difference, the smaller the torque transmission and the differential action.

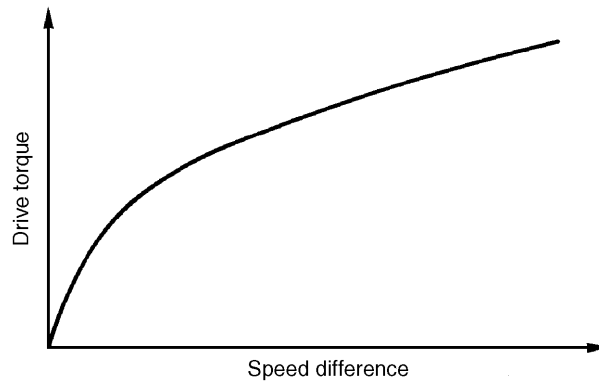

NF0122

2. HUMP PHENOMENON

Silicone oil is heated and expanded as differential action continues. This causes the pressure of air inside the viscous coupling to increase and the pressure of oil between plates to decrease. As a result, the inner and outer plates are pushed together. This direct plate-to-plate contact causes a non-viscous operation to occur, and this phenomenon is called "hump".

The hump eliminates the rotating speed difference between the center differential case and the rear side gear (or locks the differential), so soon after it has occurred, the internal pressure and temperature drop. The viscous coupling then returns to the normal shear torque transmitting operation. (The hump phenomenon does not occur under normal operating conditions.)

C: FUNCTION

When there is no speed difference between the front and rear wheels, the center differential delivers the engine torque to the front and rear wheels at a ratio of 50:50.

When a rotating speed difference occurs between the front and rear wheels, the center differential operates to absorb it in a controlled way by the function of the viscous coupling.

1. DURING NORMAL DRIVING

During straight-line driving on a flat road at a constant speed, all the four wheels rotate at the same speed. The center differential delivers engine torque evenly to the front and rear drive axles. The viscous coupling does not generate shear torque because there is no relative movements between the inner and outer plates.

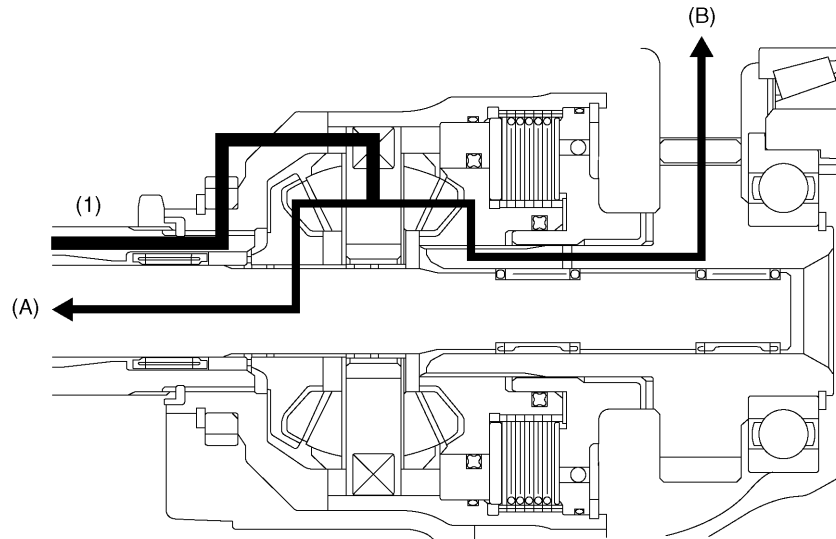

NF0613

(1) Engine torque

(A) To front differential

(B) To rear differential

CENTER DIFFERENTIAL

2. DURING TURNS AT LOW SPEEDS

During turns at low speeds, rotating speed difference occurs between the front and rear wheels, as well as between the left and right wheels. More particularly, the front wheels rotate faster than the rear wheels. The center differential then acts to absorb the speed difference to enable smooth driving.

Although the speed difference is small under this condition, operation of the viscous coupling causes more torque to be transmitted to the rear than to the front.

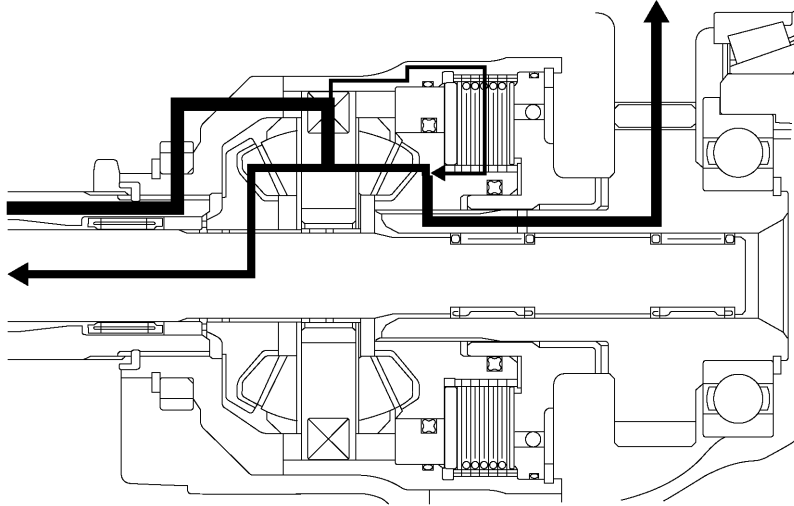

NF0614

3. DRIVING ON ROUGH OR SLIPPERY ROADS

- When front wheels are on a slippery surface

When the front wheels begin to spin, the resulting speed difference between the front and rear drive shafts causes the viscous coupling to generate significant amount of shear torque. As a result, the torque distributed to the rear wheels becomes much larger than that distributed to the spinning front wheels. The traction and driving stability are thus ensured on a rough or slippery road.

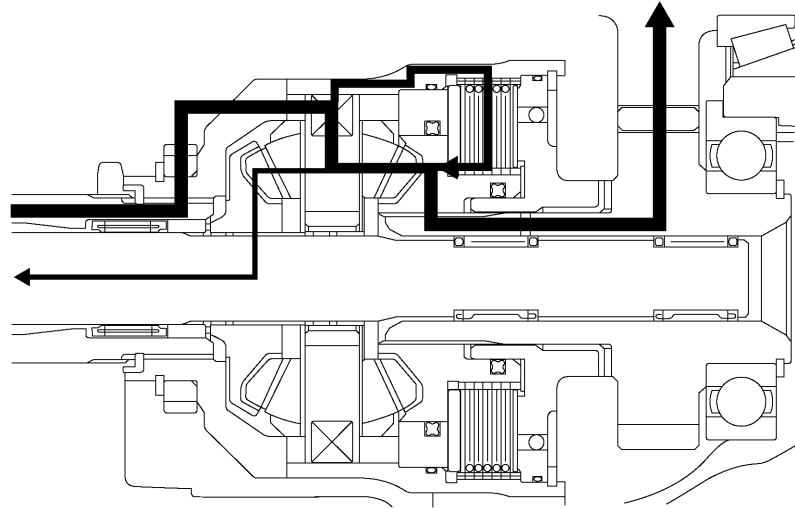

NF0615

- When rear wheels are on a slippery surface

When the vehicle is accelerated quickly from a standing start with the rear wheels on a slippery surface, the distribution of the vehicle weight on the front and rear wheels changes and the rear wheels start spinning. Due to the resulting speed difference between the front and rear drive shafts, the viscous coupling generates a significant amount of shear torque, now in the direction opposite to that generated when the front wheels are on a slippery surface. As a result, the torque distributed to the front wheels becomes much larger than that distributed to the rear wheels.

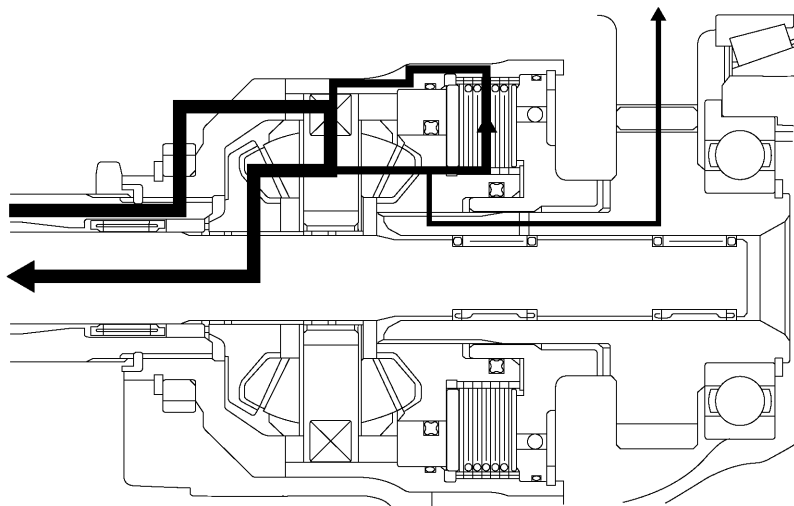

NF0616

OIL PUMP

7. Oil Pump

A: CONSTRUCTION

The lubricating oil pump incorporated in the transmission case is of a trochoid type. The pump consists of an inner rotor having four teeth, outer rotor having five teeth, oil pump cover and oil pump driven gear, which are all located at the rear of the transmission case. The pump is driven by the drive gear located on the center differential, so the delivery rate varies with the speed of the center differential. There are a pressure regulator valve and pressure relief valve on the delivery side of the pump.

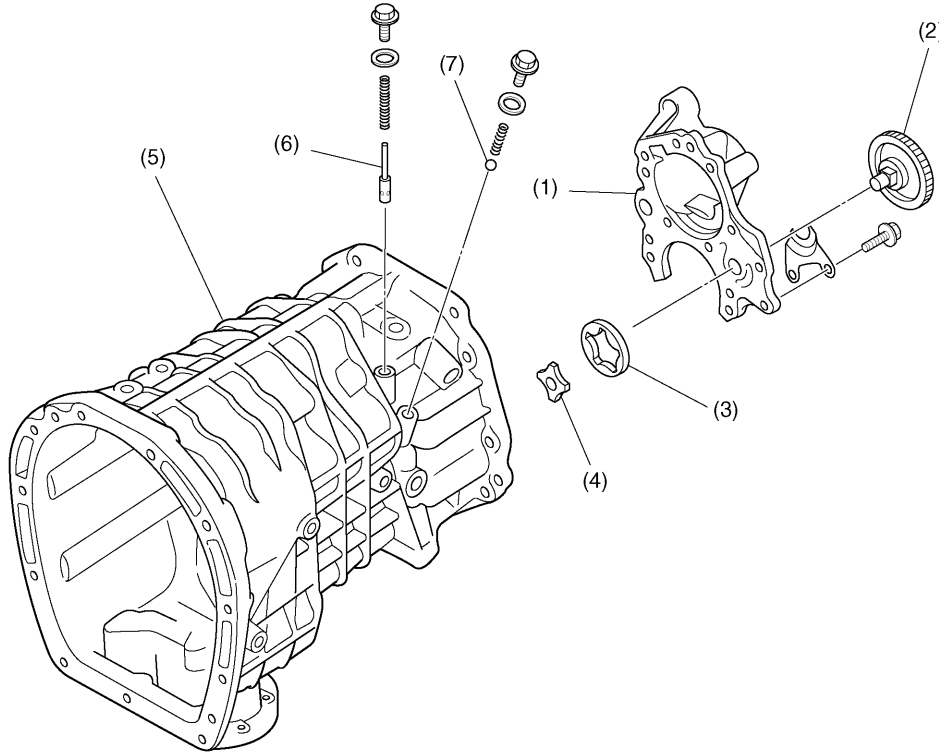

NF0617

- (1) Oil pump cover
- (2) Oil pump driven gear
- (3) Outer rotor
- (4) Inner rotor
- (5) Transmission case
- (6) Pressure regulator valve
- (7) Pressure relief valve

8. Lubrication System

A forced lubrication system using an oil pump has been employed to ensure adequate supply of oil to the components of the six-speed transmission.

The oil (gear oil) from the oil pump is distributed to the oil chamber, main shaft, drive pinion shaft, transfer gears, and other components.

The oil chamber has functions of accumulating oil and supplying with oil the central oil passage in the drive pinion shaft uninterruptedly.

In a conventional transmission without an oil chamber, the oil level is typically maintained at a height corresponding to the midpoint of the driven gear assembly. Such a large amount of gear oil (which has a relatively high viscosity) inflicts considerable frictional resistance on the gears when the transmission is operating. The use of the oil chamber can lower the oil level and thus reduce the friction between gears and oil by temporarily storing oil and supplying gears with it in an adequate amount.

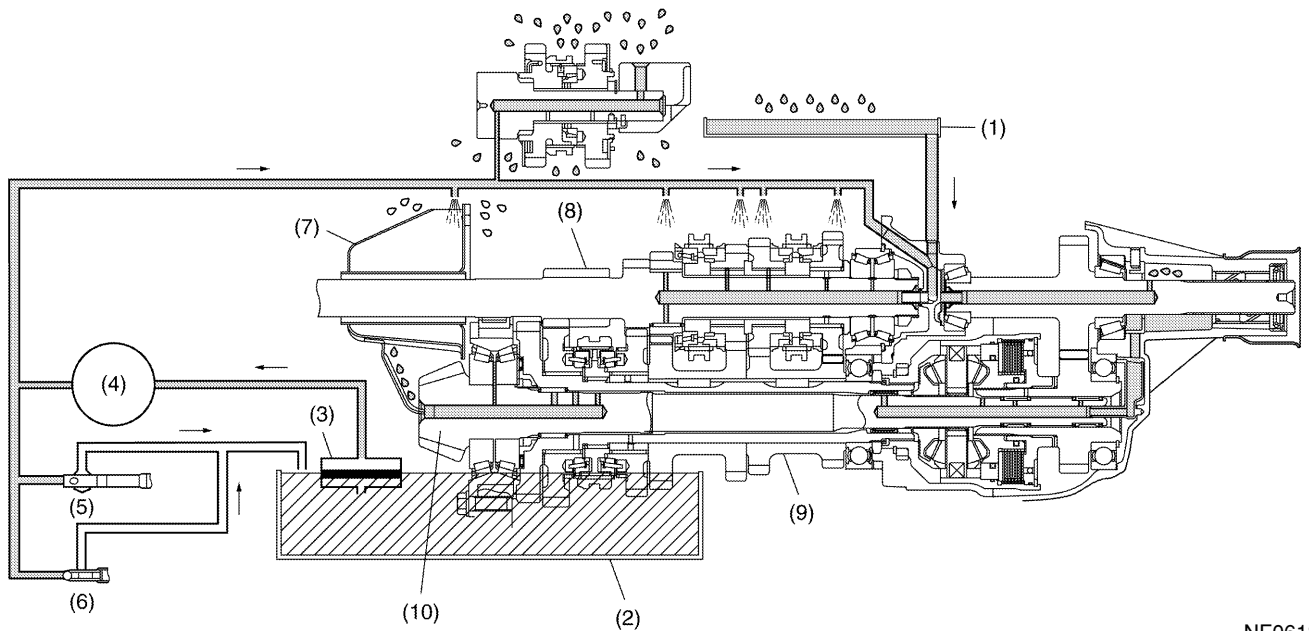

NF0618

- | | |
|------------------------------|---------------------------|
| (1) Oil guide | (6) Pressure relief valve |
| (2) Oil pan | (7) Oil chamber |
| (3) Oil strainer | (8) Main shaft |
| (4) Oil pump | (9) Driven gear assembly |
| (5) Pressure regulator valve | (10) Drive pinion shaft |

FRONT DIFFERENTIAL (SURETRAC TYPE LIMITED SLIP DIFFERENTIAL)

Manual Transmission and Differential

9. Front Differential (SURETRAC Type Limited Slip Differential)

A: OUTLINE

The limited slip differential (LSD) automatically limits the differential action and distributes torque to the left and right wheels adequately to enhance driving stability when the left and right wheels are rotating at speeds different from each other during driving on a slippery road (muddy, snow-covered or slushy road) or cornering.

B: STRUCTURE

In the SURETRAC differential, there is a set of hexagonally-shaped cam followers placed between and kept in contact with the left and right face cams (which correspond to the side gears in a conventional differential).

The cam followers engage at their outer ends with the slots that are cut on the inner surface of the cage in the axial direction, so they can slide laterally in the slots but must rotate together with the cage. Since the cam followers push the face cams as the cage rotates, the input torque to the cage is transmitted to the axle shafts.

There are a needle bearing and thrust washer pair between the face cam on each side and cage. Moreover, there is a Belleville spring between one of the needle bearing and thrust washer pairs to give preloading, thus ensuring proper initial friction between the cam followers and face cams.

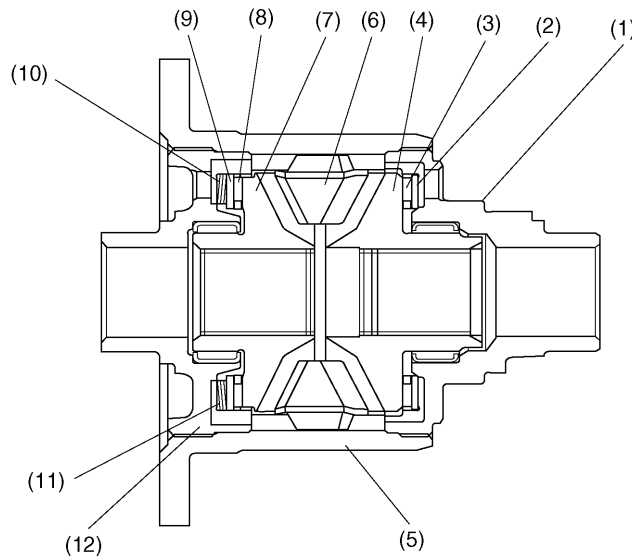

NF0619

- | | | |
|--------------------|--------------------|------------------------|
| (1) Hub | (5) Cage | (9) Thrust washer |
| (2) Thrust washer | (6) Cam follower | (10) Belleville spring |
| (3) Thrust bearing | (7) Face cam | (11) Shim |
| (4) Face cam | (8) Thrust bearing | (12) Hub |

FRONT DIFFERENTIAL (SURETRAC TYPE LIMITED SLIP DIFFERENTIAL)

Manual Transmission and Differential

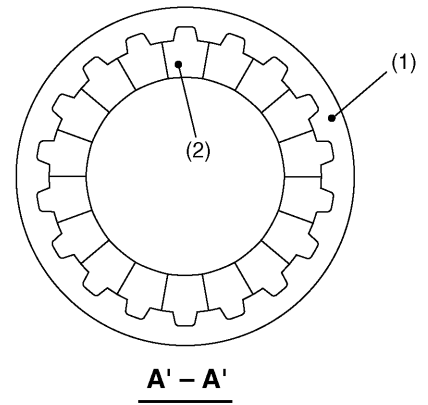
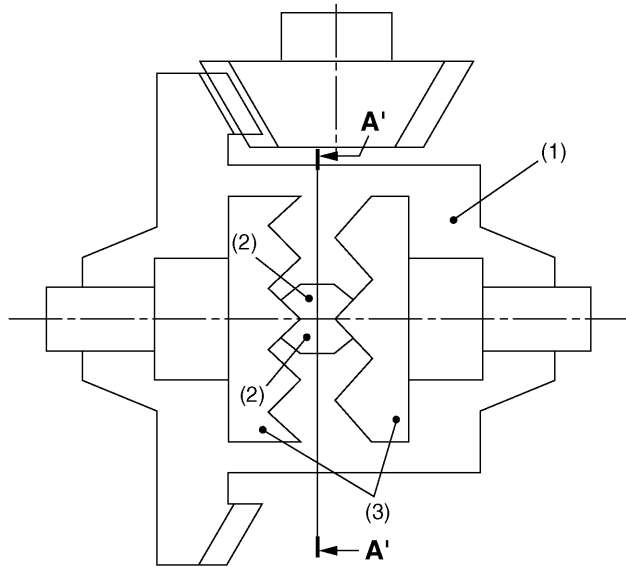

- (1) Cage
- (2) Cam follower
- (3) Face cam

NF0578

FRONT DIFFERENTIAL (SURETRAC TYPE LIMITED SLIP DIFFERENTIAL)

Manual Transmission and Differential

C: OPERATION

1. WHEN RIGHT AND LEFT WHEELS ROTATE AT DIFFERENT SPEEDS

If the left and right wheels move relative to each other in the direction of arrow Z and in the direction of arrow Y, respectively, the cam follower A is pushed by the slope B of the left face cam, moving to the right. Then the cam follower A is pushed by the slope C of the right face cam, now moving to the left.

Likewise, all the other cam followers also repeat rightward and leftward movements as long as the right and left wheels continue rotating at different speeds, so the vehicle can turn a corner smoothly.

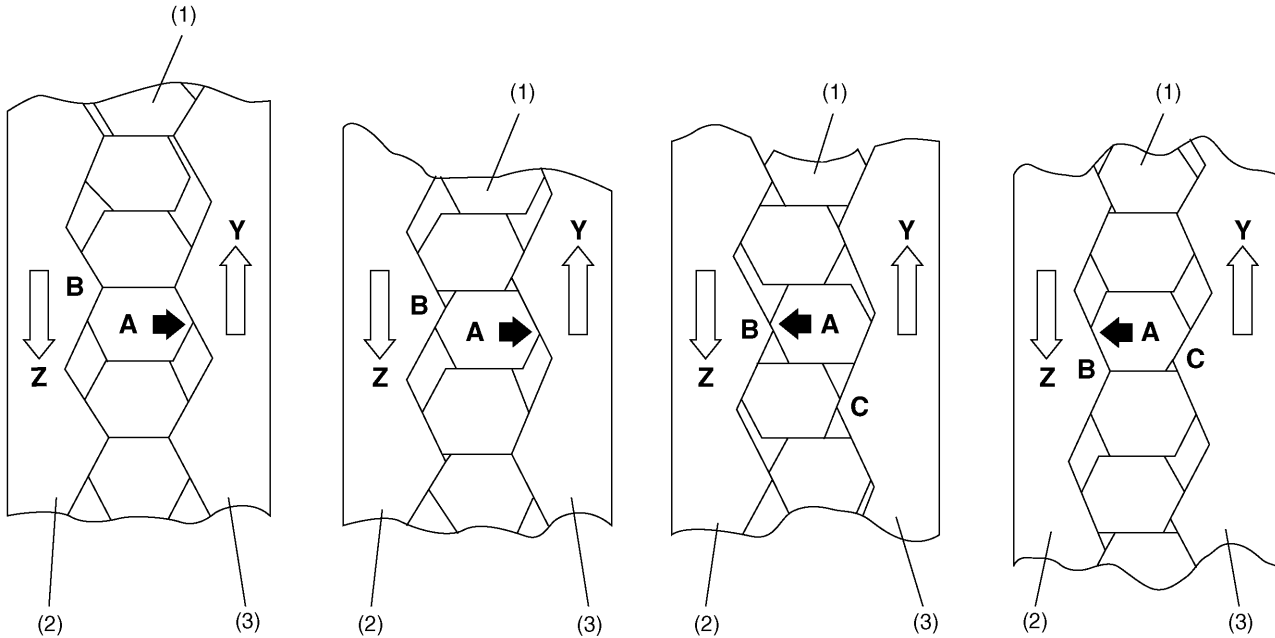

NF0579

- (1) Cam follower
- (2) Left face cam
- (3) Right face cam

FRONT DIFFERENTIAL (SURETRAC TYPE LIMITED SLIP DIFFERENTIAL)

Manual Transmission and Differential

2. WHEN RIGHT AND LEFT WHEELS ROTATE AT THE SAME SPEED

During normal straight-ahead driving where the right and left wheels rotate at the same speed, the cage and cam followers rotate together, just as in conventional differentials. As a result, driving torque is distributed equally to the right and left side gears.

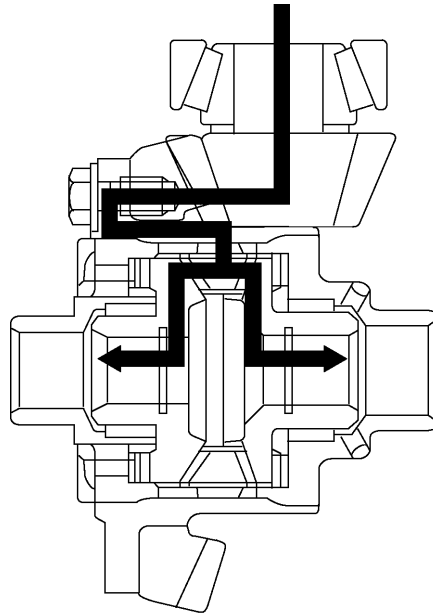

NF0620

FRONT DIFFERENTIAL (SURETRAC TYPE LIMITED SLIP DIFFERENTIAL)

Manual Transmission and Differential

3. WHEN TRACTION IS DIFFERENT BETWEEN RIGHT AND LEFT WHEELS

For example, if the left wheel spins on a slippery surface and loses traction, the left face cam starts rotating at a speed faster than the right wheel.

Like when the right and left wheels rotate at different speeds mentioned earlier, the cam follower A starts moving to the left.

This time, however, as the right wheel has traction, the drive torque pushes the cam follower A strongly against the right face cam when it makes the cam follower get over the slope B of the face cam, generating a large friction force between the contacting surfaces (shown by a thick line in the drawing).

This large friction force allows the drive torque to be transmitted to the right wheel.

In this way, the SURETRAC differential can keep the drive torque distributed to a wheel with traction even when the other wheel spins and loses traction.

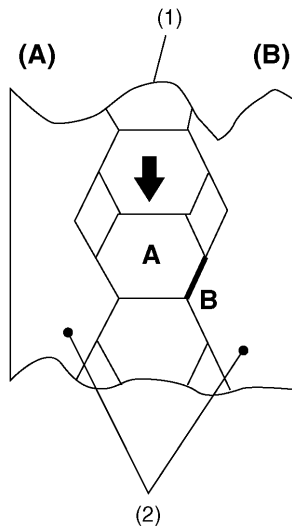

NF0565

(1) Cam follower

(2) Face cam

(A) High speed rotation

(B) Low speed rotation

D: SERVICE PROCEDURES FOR LSD

It is not recommended to disassemble this LSD assembly as components of this LSD assembly are not available individually.

10. Transmission Mounting

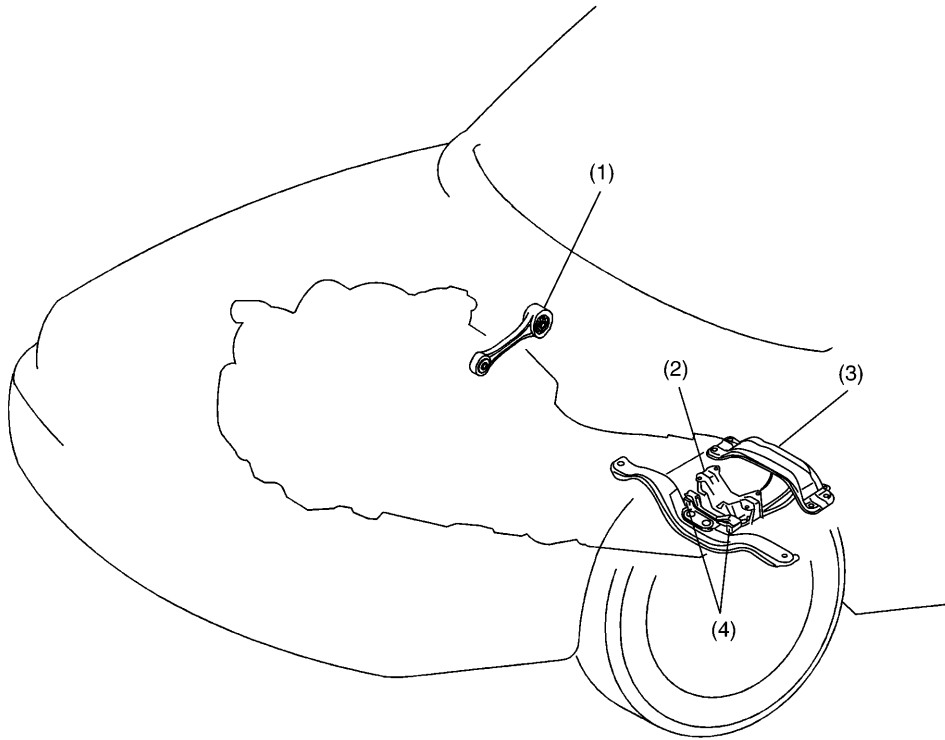

- (1) Pitching stopper
- (2) Cushion rubber
- (3) Cross member
- (4) Dynamic damper (Europe model)

NF0628

TRANSMISSION MOUNTING

Manual Transmission and Differential

MEMO

CLUTCH *CL*

	Page
1. Outline	
2. Operation	
3. Cross Sectional View	2
4. Flywheel	
5. Mechanical Clutch Pedal System	
6. Hydraulic Clutch Pedal System	
7. Fluid Control System (STi Model)	3

CROSS SECTIONAL VIEW

Clutch

3. Cross Sectional View E: STi MODEL

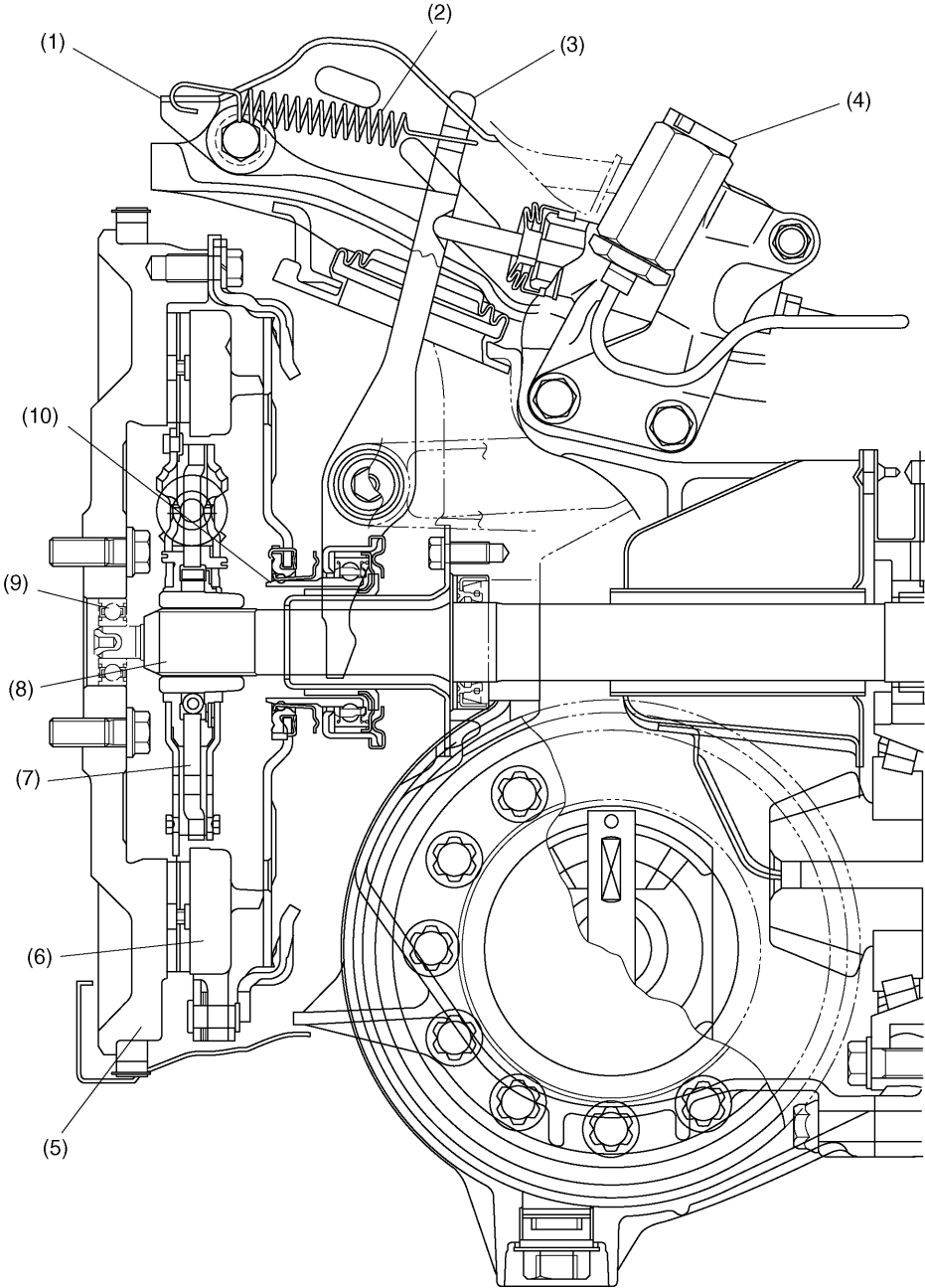

NF0621

- (1) Spring bracket
- (2) Spring
- (3) Release lever
- (4) Operating cylinder
- (5) Flywheel
- (6) Clutch cover
- (7) Clutch disc
- (8) Transmission main shaft
- (9) Ball bearing
- (10) Release bearing

7. Fluid Control System (STi Model)

The clutch operating cylinder incorporates a temperature sensitive orifice unit which controls the clutch engaging speed depending on the fluid temperature to ensure smooth standing starts irrespective of atmospheric temperatures.

A: CONSTRUCTION

The orifice unit consists of an orifice retainer, an orifice valve, and two springs that support the orifice valve.

One of the springs is made of the shape memory alloy that prevents a delay in clutch response when the weather is cold and the oil viscosity is high.

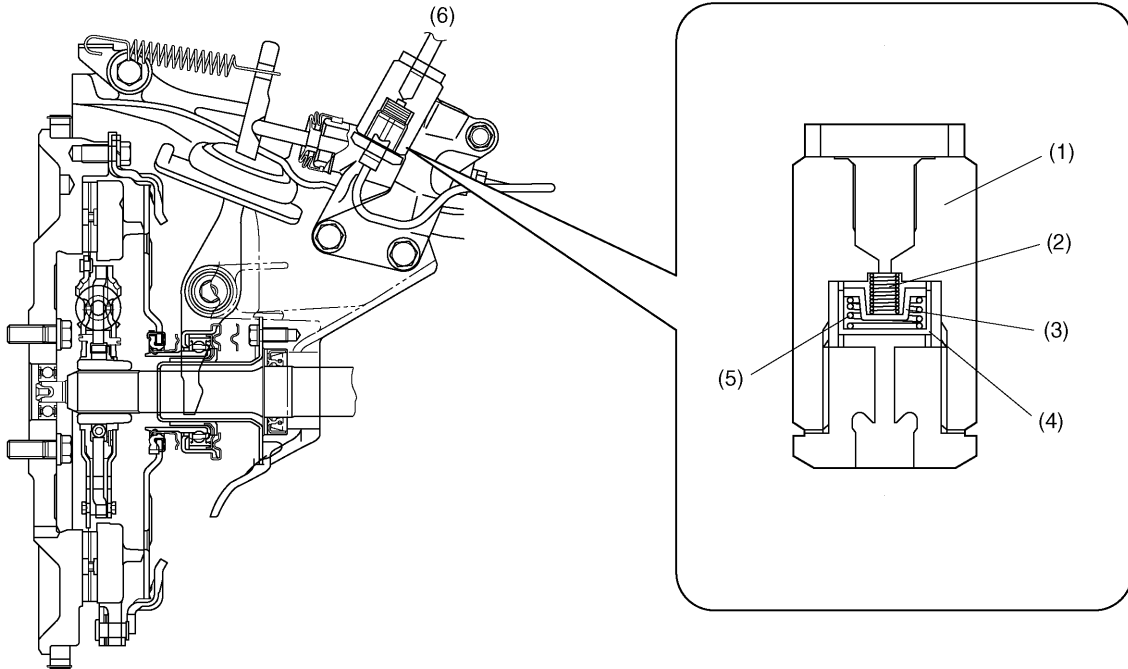

- (1) Body
- (2) No. 2 spring
- (3) Orifice valve

- (4) Orifice retainer
- (5) No. 1 spring
- (6) To master cylinder

NF0622

FLUID CONTROL SYSTEM (STi MODEL)

Clutch

B: OPERATION

The No. 1 spring is made of a shape memory alloy that contracts and loses the tension when the temperature is low.

When the temperature is high, the orifice valve is kept in a raised position by the No. 1 spring, so the fluid passage is narrow. When the temperature drops, the No. 1 spring contracts, allowing the orifice valve to be pushed down by the No. 2 spring. Now, the fluid passage in the orifice unit opens wide.

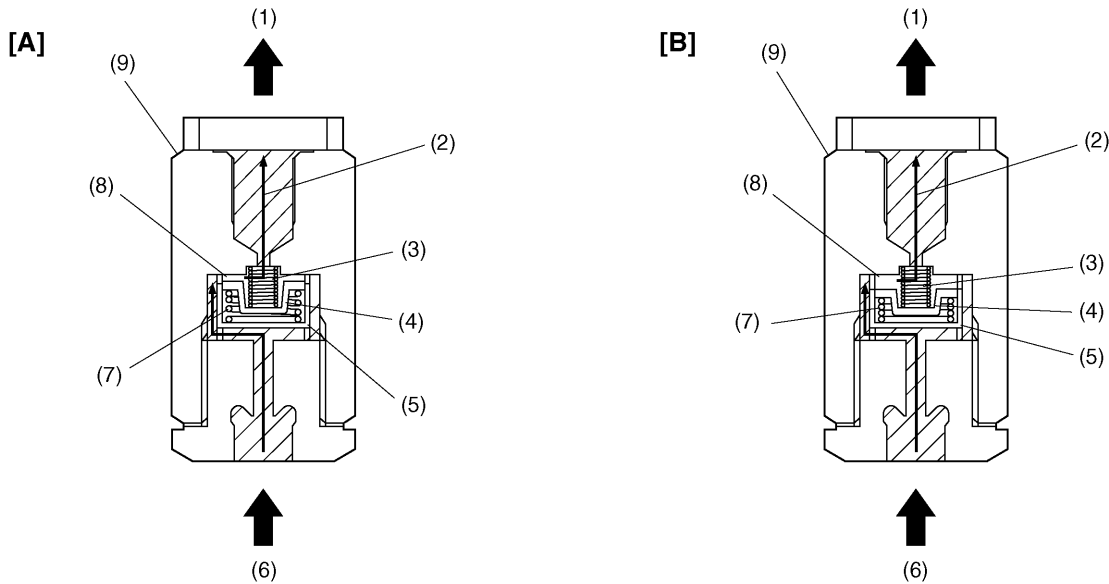

NF0623

[A] In high temperatures

[B] In low temperatures

(1) To master cylinder

(2) Flow of fluid with clutch pedal released

(3) No. 2 spring

(4) Orifice valve

(5) Orifice retainer

(6) From operating cylinder

(7) No. 1 spring

(8) Orifice gap

(9) Body

FRONT SUSPENSION

FS

Page

1. Front Suspension	2
---------------------------	---



1. Front Suspension

A: OUTLINE

1. STi MODEL

The struts are of an upside-down type, which can provide increased rigidity. They also improve the steering stability.

B: CONSTRUCTION

3. UPSIDE-DOWN-TYPE STRUTS (STi MODEL)

Compared with a conventional suspension strut, the upside-down-type strut has a shock absorber with its top and bottom reversed. This arrangement is advantageous in increasing rigidity as it allows the diameter of the damping tube (which corresponds to the piston rod in the conventional arrangement) to be increased to an almost same diameter as the strut's outer tube diameter.

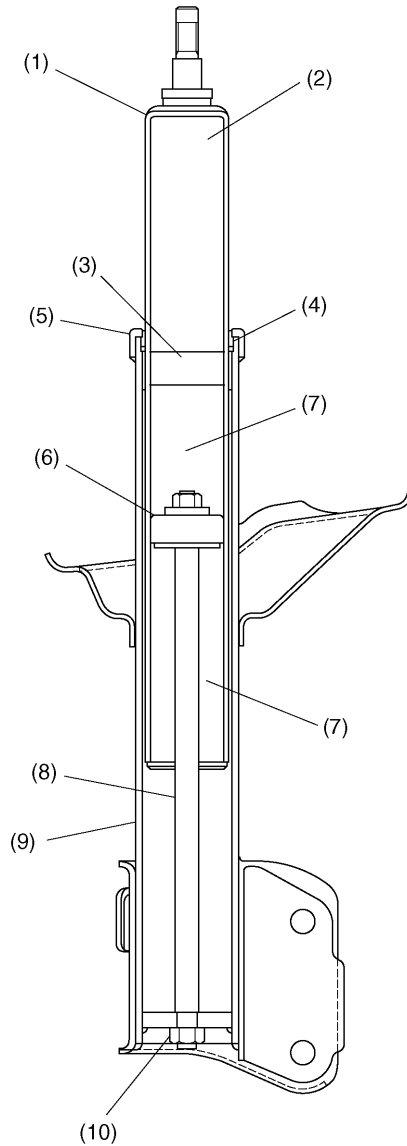

- | | |
|------------------|----------------|
| (1) Damping tube | (6) Piston |
| (2) Gas | (7) Oil |
| (3) Free piston | (8) Piston rod |
| (4) Oil seal | (9) Outer tube |
| (5) Cap | (10) Nut |

NF0584

FRONT SUSPENSION

Front Suspension

MEMO

REAR SUSPENSION

RS

Page

1. Rear Suspension.....	2
-------------------------	---

REAR SUSPENSION

Rear Suspension

1. Rear Suspension

A: OUTLINE

1. STi MODEL

As is the case with the front suspension, the rear suspension uses upside-down struts.

DIFFERENTIALS

DI

Page

- 1. Rear Differential 2
- 2. Limited Slip Differential (LSD) (Viscous Coupling Type)
- 3. Limited Slip Differential (LSD) (SURETRAC Type)

REAR DIFFERENTIAL

Differentials

1. Rear Differential

B: T-TYPE

2. STi MODEL

The drive gear is a hypoid gear with a nominal diameter of 180 mm (7.09 in). The drive pinion shaft is supported by three bearings. The bearing preload is adjusted by selecting a spacer and washer combination of a proper thickness. The drive pinion height is adjusted by properly selecting the thickness of the washers located at the drive pinion neck using Dummy Shaft and Gauge.

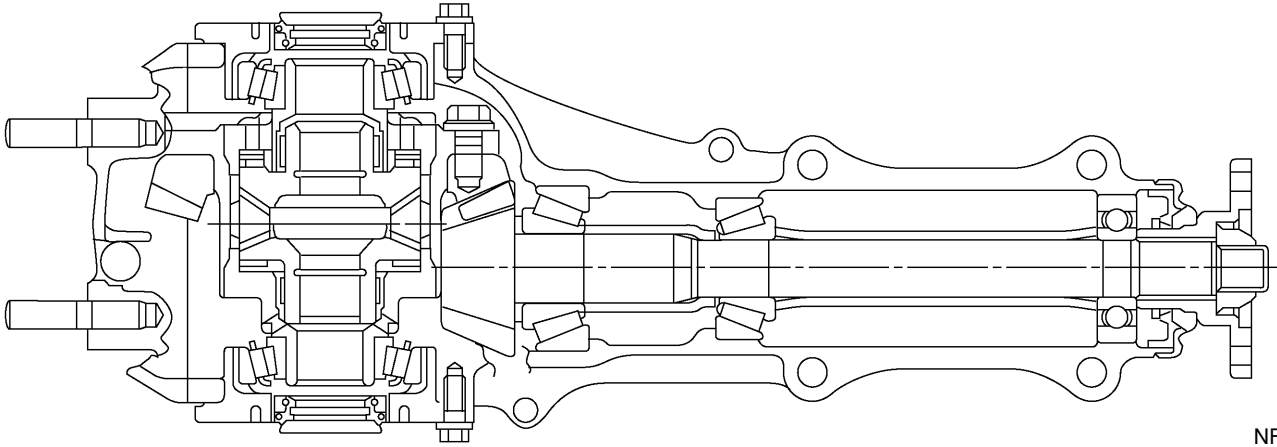

NF0595

DRIVE SHAFT SYSTEM

DS



	Page
1. Propeller Shaft	2
2. Front Axle	3
3. Rear Axle.....	5



PROPELLER SHAFT

Drive Shaft System

1. Propeller Shaft

C: STi MODEL

The propeller shaft is of a two-piece design that uses three joints.

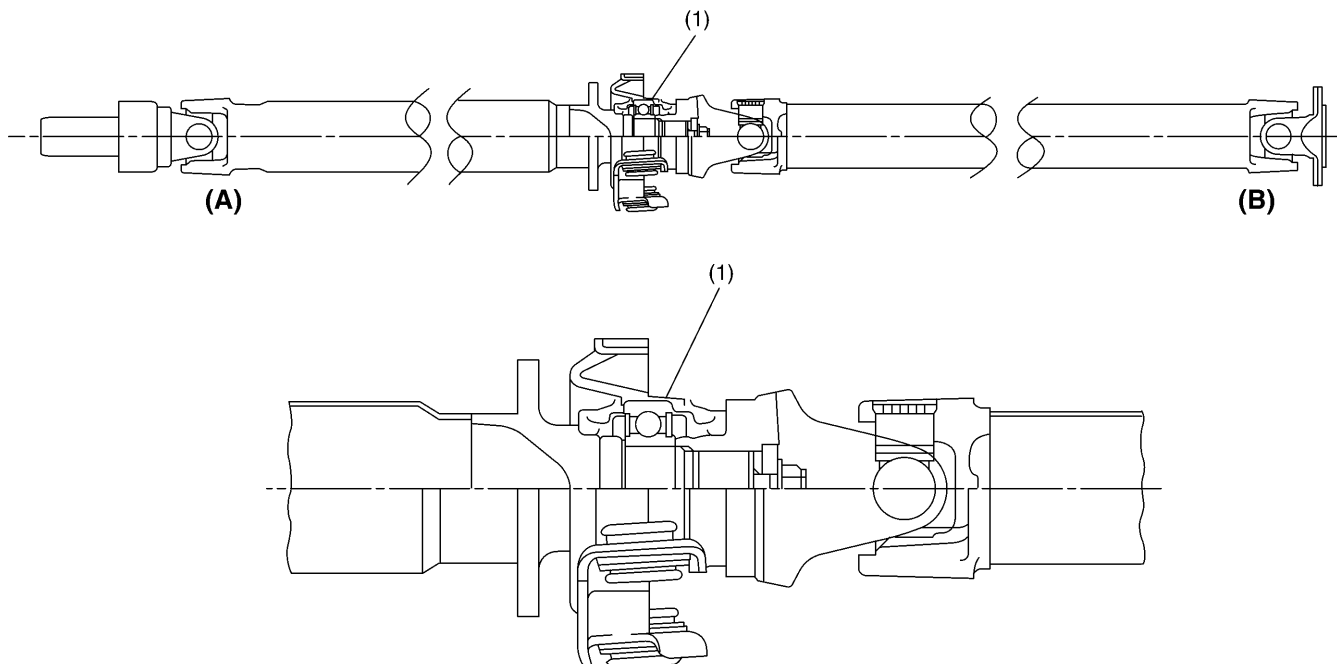

NF0558

(1) Center bearing

(A) Transmission side

(B) Rear differential side

2. Front Axle

A: GENERAL

2. STi MODEL

- The inboard end of the axle shaft is connected to the transmission via a constant velocity joint (double offset joint: DOJ) which is flexible in the axial directions, while the outboard end is connected via a bell joint (BJ) to the wheel hub which is supported by a taper roller bearing located inside the axle housing. The BJ features a large operating angle.
- Both the constant velocity joints (DOJ and BJ) ensure smooth, regular rotation of the drive wheels with minimum vibration.
- The bearing is a preloaded, non-adjustable tapered roller unit bearing. Each hub is fitted in the axle housing via the tapered roller bearing.
- The BJ's spindle is splined to the hub and is secured with an axle nut clinched to it.
- The disc rotor is an external mounting type. It is secured to the disc wheel using hub bolts to facilitate maintenance of the disc rotor.

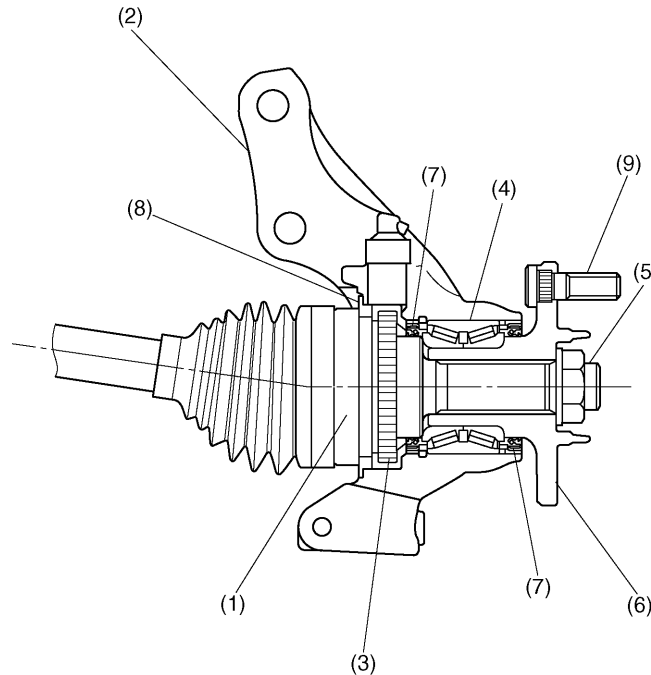

- | | | |
|------------------|--------------|------------------|
| (1) BJ | (4) Bearing | (7) Oil seal |
| (2) Axle housing | (5) Axle nut | (8) Baffle plate |
| (3) Tone wheel | (6) Hub | (9) Hub bolt |

NF0151

FRONT AXLE

Drive Shaft System

B: FRONT DRIVE SHAFT

2. STi MODEL

- A double offset joint (DOJ) is used on the differential side of each front drive shaft. The DOJ can be disassembled for maintenance. It provides a maximum operating angle of 25° and can be moved in the axial directions.
- A bell joint (BJ) is used on the wheel side of each front drive shaft. The BJ's maximum operating angle is 47.1° .

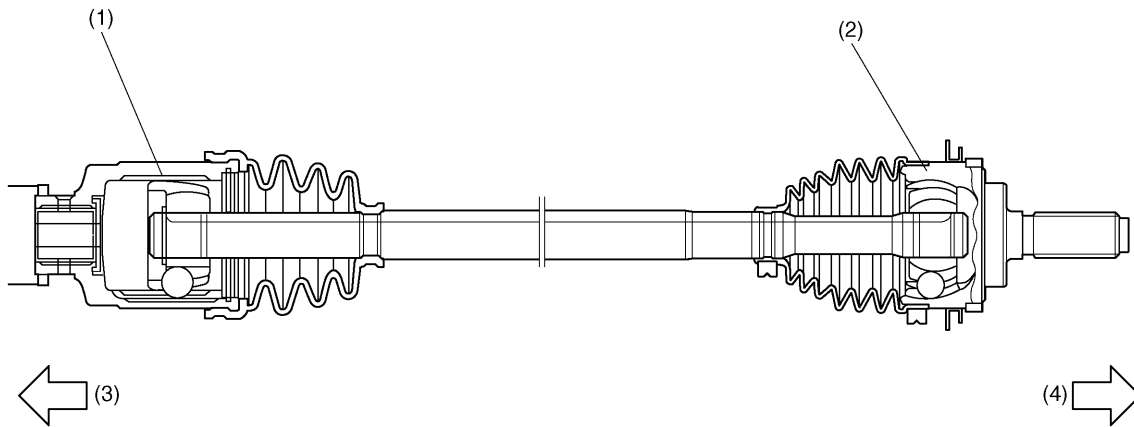

NF0589

- (1) DOJ
- (2) BJ

- (3) Transmission side
- (4) Wheel side

3. Rear Axle

C: AWD TURBO MODELS

2. STi MODEL

- The inboard end of each axle shaft is connected to the transmission via a double offset joint (DOJ) which can extend and retract in the axial directions.
- The outboard end is supported by taper roller bearings located inside the axle housing via a bell joint (BJ) which features a large operating angle. Both the constant velocity joint (DOJ and BJ) ensure smooth, regular rotation of the drive wheels with minimum vibration.
- The bearing is a preloaded, non-adjustable taper roller unit type. Each hub is fitted in the axle housing via the taper roller bearing.
- The BJ's spindle is splined to the hub and secured with an axle nut clinched to it.
- The disc rotor is held in position by the hub bolts and wheel nuts together with the wheel. This facilitates removal and installation of the disc rotor and thus improves serviceability.

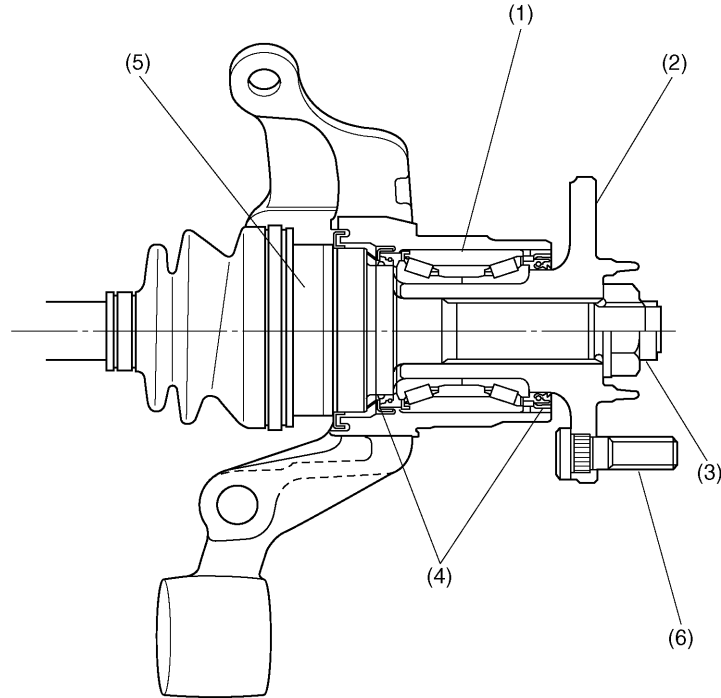

(1) Tapered roller bearing

(2) Hub

(3) Axle nut

(4) Oil seal

(5) BJ

(6) Hub bolt

NF0590

REAR AXLE

D: REAR DRIVE SHAFT

3. TURBO MODELS (STi MODEL)

- A double offset joint (DOJ) is used on the differential side of each rear drive shaft. The DOJ can be disassembled for maintenance. It provides a maximum operating angle of 23° and can be moved in the axial directions.
- A bell joint (BJ) is used on the wheel side of each rear drive shaft. Its maximum operating angle is 43.4° .

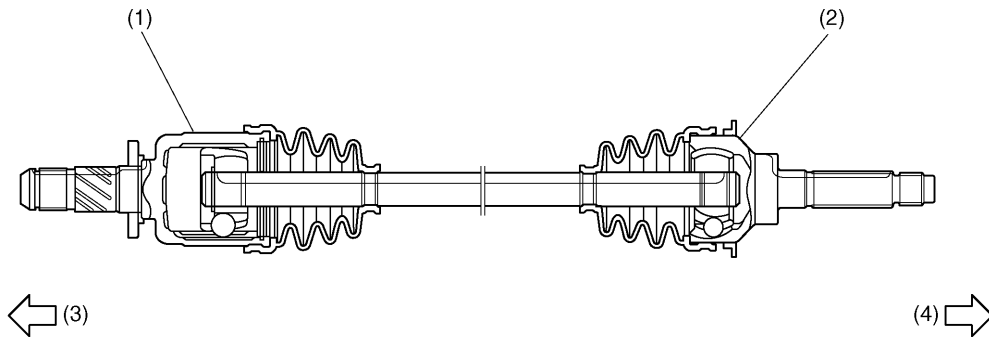

NF0591

- (1) DOJ
- (2) BJ
- (3) Differential side
- (4) Wheel side

ABS *ABS*

	Page
1. Anti-lock Brake System (ABS)	2



1. Anti-lock Brake System (ABS)

A: FEATURE

- The 5.3i type ABS used in the Impreza has a hydraulic control unit, an ABS control module, a valve relay and a motor relay integrated into a single unit (called “ABSCM & H/U”) for circuit simplicity and reduced weight.
- The ABS electrically controls the brake fluid pressure to each wheel to prevent the wheel from locking during braking on slippery road surfaces, thereby enabling the driver to maintain the directional control.
- If the ABS becomes inoperative, a fail-safe system is activated to ensure same level of braking performance as with a conventional brake system. In that case, the warning light comes on to indicate that the ABS is malfunctioning.
- The ABS is a 4-sensor, 4-channel system; the front wheel system is an independent control design*¹, while the rear wheel system is a select-low control design*².

*1: A system which controls the front wheel brakes individually.

*2: A system which applies the same fluid pressure to both the rear wheels if either wheel starts to lock. The pressure is determined based on the lower of the frictional coefficients of both wheels.

- The STi model is equipped with a Sports ABS. The Sports ABS is different from the standard ABS with an electronic brake force distribution (EBD) function in that it has an additional lateral G sensor. When the G sensor senses large lateral acceleration exceeding the predetermined level during a turn, the ABS switches the rear braking control mode from the select-low control to the independent control in order to improve the braking performance during cornering.

ANTI-LOCK BRAKE SYSTEM (ABS)

ABS

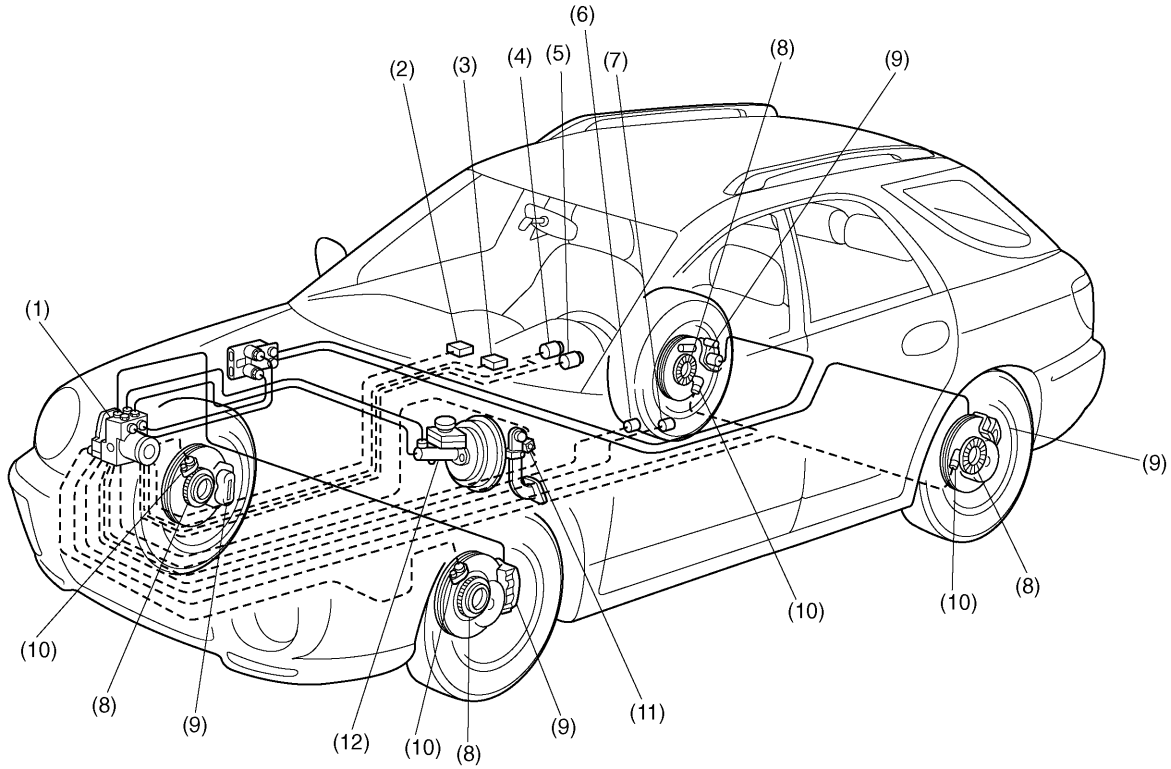

NF0586

- | | | |
|---|---------------------------------------|----------------------|
| (1) ABS control module and hydraulic control unit (ABSCM & H/U) | (5) Brake warning light | (9) Wheel cylinder |
| (2) Diagnosis connector | (6) G sensor | (10) ABS sensor |
| (3) Data link connector (for SUBARU select monitor) | (7) Lateral G sensor (Only STi model) | (11) Brake switch |
| (4) ABS warning light | (8) Tone wheel | (12) Master cylinder |

ANTI-LOCK BRAKE SYSTEM (ABS)

ABS

B: FUNCTIONS OF SENSORS AND ACTUATORS

Name		Function
ABS control module and hydraulic control unit (ABSCM & H/U)	ABSCM section	<ul style="list-style-type: none"> It determines the conditions of the wheels and the vehicle body from the wheel speed data and controls the hydraulic unit depending on the result. When the ABS is active, the ABSCM provides the automatic transmission control module with control signals which are used by the module for cooperative control of the vehicle with the ABSCM. Whenever the ignition switch is placed at ON, the module performs a self diagnosis sequence. If anything wrong is detected, the module cuts off the system. It communicates with the SUBARU select monitor.
	H/U section	<ul style="list-style-type: none"> When the ABS is active, the H/U changes fluid passages to the wheel cylinders in response to commands from the ABSCM. It constitutes the brake fluid passage from the master cylinder to the wheel cylinders together with the piping.
	Valve relay section	It serves as a power switch for the solenoid valves and motor relay coil. It operates in response to a command from the ABSCM.
	Motor relay section	It serves as a power switch for the pump motor. It operates in response to a command from the ABSCM.
ABS sensors (wheel speed sensors)		They detect the wheel speed in terms of a change in the density of the magnetic flux passing through them and convert it into an electrical signal. The electrical signal is sent to the ABSCM.
Tone wheels		They give a change in the magnetic flux density by the teeth around themselves to let the ABS sensors generate electrical signals.
G sensor		It detects a change in acceleration in the longitudinal direction of the vehicle and outputs it to the ABSCM as a voltage signal.
Lateral G sensor (STi model)		It detects lateral acceleration (G) during a turn and sends a voltage signal proportional to the G value to the ABSCM.
Stop light switch		It provides information on whether the brake pedal is depressed or not to the ABSCM. The ABSCM uses it to determine ABS operation.
ABS warning light		It alerts the driver to an ABS fault. When the diagnosis connector and diagnosis terminal are connected, the light flashes to indicate a trouble code stored in the ABSCM.
Automatic transmission control module		It provides gear controls (fixing the speed at 3rd or changing power transmission to front and rear wheels) in response to control signals from the ABSCM.
Brake warning light		It alerts the driver to an EBD fault. This warning light is also used for parking brake warning and brake fluid level warning.

ANTI-LOCK BRAKE SYSTEM (ABS)

ABS

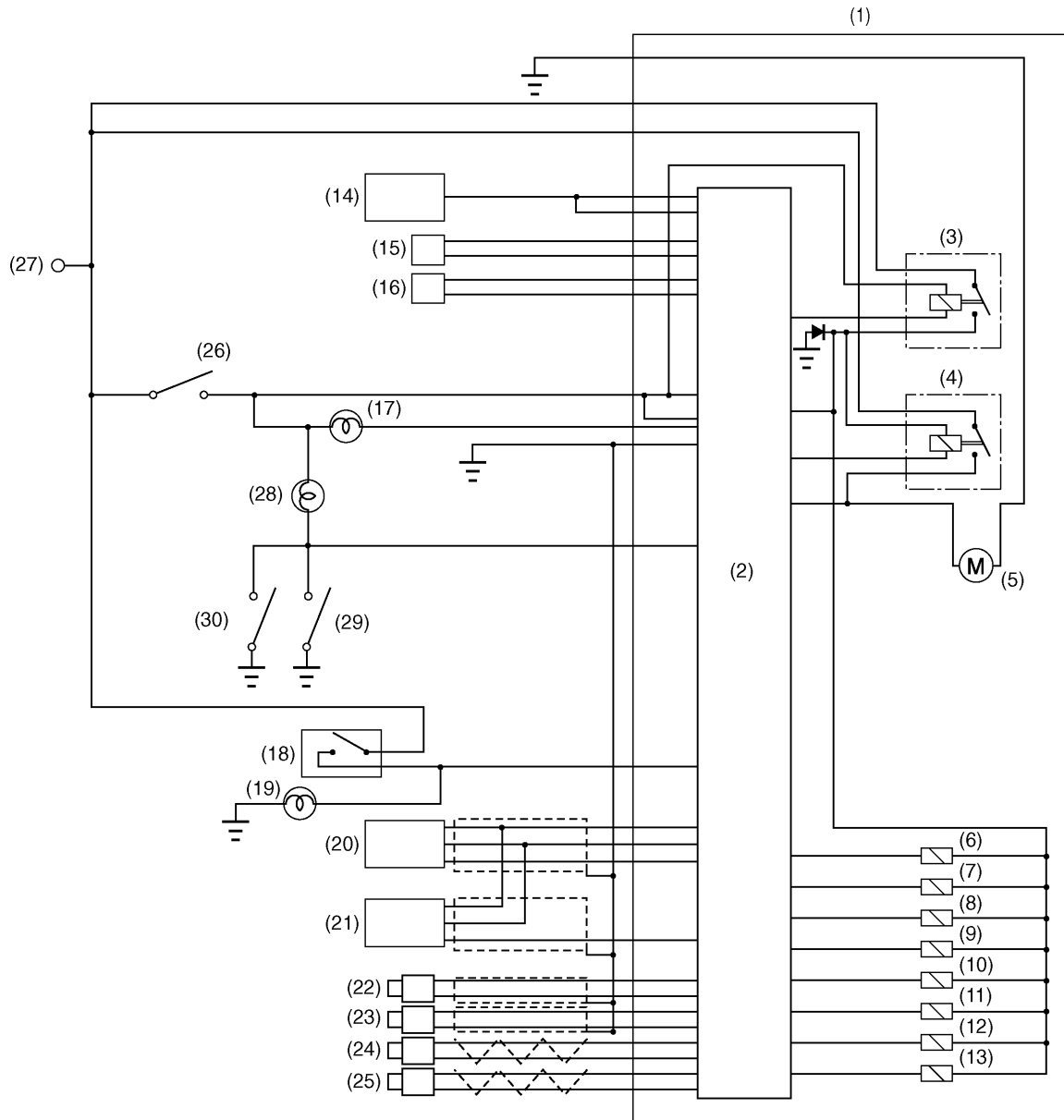

NF0587

- | | | |
|---|--|--|
| (1) ABS control module and hydraulic control unit | (11) Rear left outlet solenoid valve | (21) Lateral G sensor (Only STi model) |
| (2) ABS control module section | (12) Rear right inlet solenoid valve | (22) Front left ABS sensor |
| (3) Valve relay | (13) Rear right outlet solenoid valve | (23) Front right ABS sensor |
| (4) Motor relay | (14) Automatic transmission control module | (24) Rear left ABS sensor |
| (5) Motor | (15) Diagnosis connector | (25) Rear right ABS sensor |
| (6) Front left inlet solenoid valve | (16) Data link connector | (26) IGN |
| (7) Front left outlet solenoid valve | (17) ABS warning light | (27) BATTERY |
| (8) Front right inlet solenoid valve | (18) Stop light switch | (28) Brake warning light |
| (9) Front right outlet solenoid valve | (19) Stop light | (29) Parking brake switch |
| (10) Rear left inlet solenoid valve | (20) G sensor | (30) Brake fluid level switch |

ANTI-LOCK BRAKE SYSTEM (ABS)

ABS

J: LATERAL G SENSOR (STi MODEL)

The lateral G sensor senses variation in the lateral acceleration while the vehicle is making a turn. Its construction and operation are the same as those of the conventional G sensor, which converts changes in the piezoresistivity into changes in the output voltage to the ABSCM.

BRAKES *BR*

	Page
1. Front and Rear Disc Brakes	2
2. Rear Drum Brakes	
3. Master Cylinder	
4. Brake Booster	
5. Proportioning Valve (1.6 L and 2.0 L model without ABS)	
6. Hill Holder	

FRONT AND REAR DISC BRAKES

Brakes

1. Front and Rear Disc Brakes

C: STi MODEL

- The brakes of the STi model use Brembo's 17-inch calipers and ventilated disc rotors that provide improved braking performance.
- The brake calipers for the front brakes are of a four-pod-piston type, while those for the rear brakes are of a two-pod-piston type.

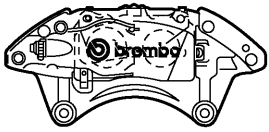
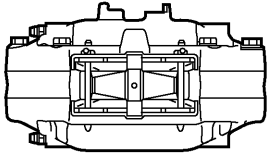

(1)

(1) Front

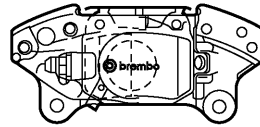
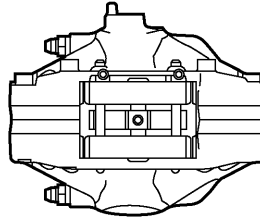

(2)

(2) Rear

NF0588

INSTRUMENTATION/DRIVER INFO



Page

1. Combination Meter	2
2. Outside Air Temperature Display	

COMBINATION METER

Instrumentation/Driver Info

1. Combination Meter

A: WARNING AND INDICATOR LIGHTS

2. STi MODEL

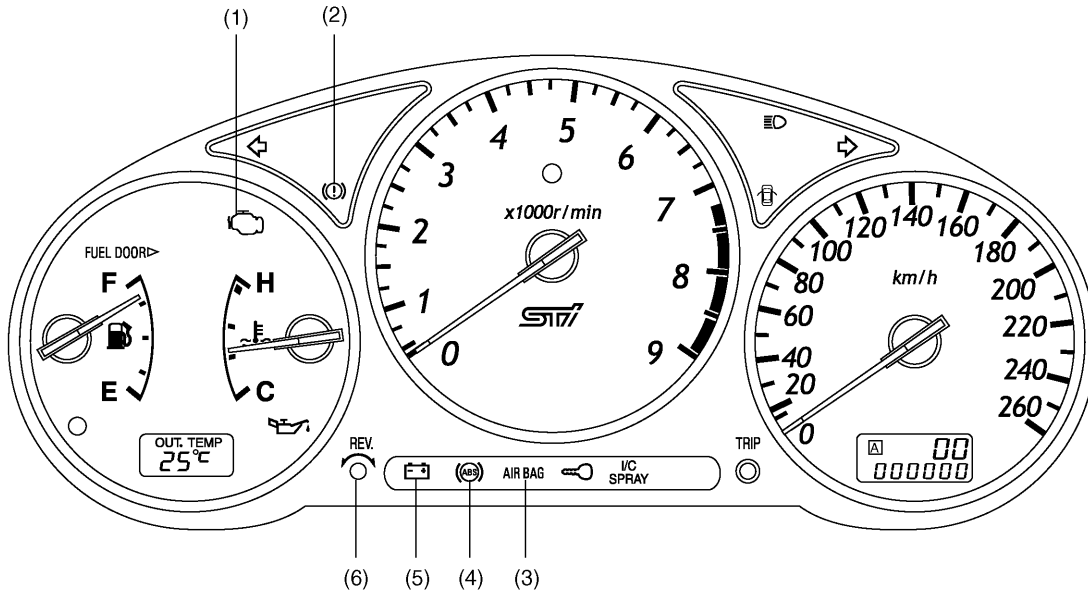

NF0592

- (1) CHECK ENGINE warning light
This light illuminates when a fault occurs in the MFI (Multiple point Fuel Injection) system.
- (2) Brake fluid level warning / parking brake indicator light
This light illuminates when the fluid level in the brake reservoir tank lowers below the specified level and/or when the parking brake is applied.
- (3) AIRBAG system warning light
This light illuminates when a fault occurs in the airbag system.
- (4) ABS warning light
This light illuminates when a fault occurs in any electrical component of the ABS (Anti-lock Brake System).
- (5) Charge indicator light
This light illuminates when a fault occurs in the charging system while the engine is running.
- (6) Oil pressure warning light
This light illuminates when the engine oil pressure decreases below 14.7 kPa (0.15 kgf/cm², 2.1 psi).

COMBINATION METER

If everything is normal, the warning and indicator lights should be ON or OFF as shown below according to ignition switch positions.

Warning/Indicator light	Ignition switch position			
	LOCK/ACC	ON	ST	While engine is running
(1) CHECK ENGINE	OFF	*1	ON	OFF
(2) Brake fluid level / parking brake	OFF	ON	ON	*4
(3) AIRBAG	OFF	*2	ON	*2
(4) ABS	OFF	*3	ON	OFF
(5) Charge	OFF	ON	ON	OFF
(6) Oil pressure	OFF	ON	ON	OFF

*1: This light comes ON before engine starts, and stays OFF after engine has started.

*2: This light comes ON for about 7 seconds, and then goes out.

*3: This light comes ON for about 2 seconds, and then goes out.

*4: This light comes ON when the parking brake is applied.

COMBINATION METER

Instrumentation/Driver Info

B: TELLTALE (GRAPHIC MONITOR)

2. STi MODEL

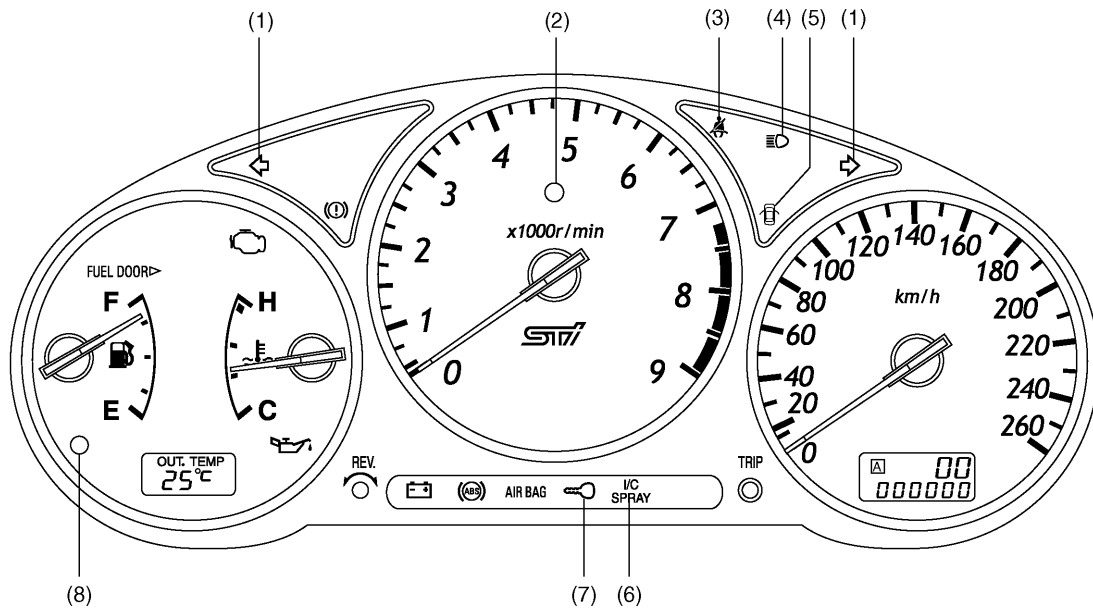

NF0593

- (1) Turn signal indicator light
This light blinks in unison with the corresponding turn signal lights when the turn signal switch is operated.
- (2) REV indicator light
This light illuminates when a preset engine speed is exceeded.
- (3) Seat belt warning light
This light stays illuminated for about 6 seconds after the ignition switch has been turned ON if the driver's seat belt is not fastened.
- (4) Headlight beam indicator light
This light illuminates when the headlights are in the high-beam position.
- (5) Door open warning light
This light illuminates when one or more doors and/or rear gate are not completely closed.
- (6) Intercooler water spray warning light
This light illuminates when the water level in the water tank lowers.
- (7) Immobiliser indicator light
This light illuminates when the immobiliser system is armed.
- (8) Low fuel warning light
This light illuminates when the quantity of the fuel remaining in the tank has decreased to 10 liters (2.6 US gal, 2.2 Imp gal) or smaller.

COMBINATION METER

If everything is normal, the telltales should be ON, OFF or in other states as shown below according to ignition switch positions.

Telltale light		Ignition switch position			
		LOCK/ACC	ON	ST	While engine is running
(1) Turn signal		OFF	Blink	Blink	Blink
(2) REV		OFF	*4	*4	*4
(3) Seat belt		OFF	*2	*2	*2
(4) Headlight beam	● High beam	OFF	ON	ON	ON
	● Low beam	OFF	OFF	OFF	OFF
(5) Door or rear gate open	● Open	ON	ON	ON	ON
	● Shut	OFF	OFF	OFF	OFF
(6) Intercooler water spray		OFF	*5	*5	*5
(7) Immobiliser		*3	OFF	OFF	OFF
(8) Low fuel		OFF	*1	*1	*1

*1: This light illuminates when quantity of the fuel remaining in the tank has decreased to 10 liters (2.6 US gal, 2.2 Imp gal) or smaller.

*2: This light stays illuminated for about 6 seconds after the ignition switch has been turned ON if the driver's seat belt is NOT fastened.

*3: This light blinks when the ignition key has been removed from the ignition switch, or when 60 seconds or more time has passed after the ignition key was inserted in the ignition switch and was turned to the LOCK or ACC position.

*4: This light stays illuminated as long as the engine speed is above the driver's setting.

*5: This warning light illuminates when the water in the intercooler water spray tank decreases to approximately 0.4 liters.

COMBINATION METER

Instrumentation/Driver Info

E: TACHOMETER

2. REV INDICATOR LIGHT

The REV indicator light operates together with a buzzer when the engine starts operating at a speed exceeding the speed the driver has set as desired, giving him or her a warning. The light remains illuminated as long as the engine speed is above the set speed. The buzzer sounds intermittently for a short time when the engine speed exceeds the setting. Setting is possible at any speed within the range between 2000 and 7500 rpm.

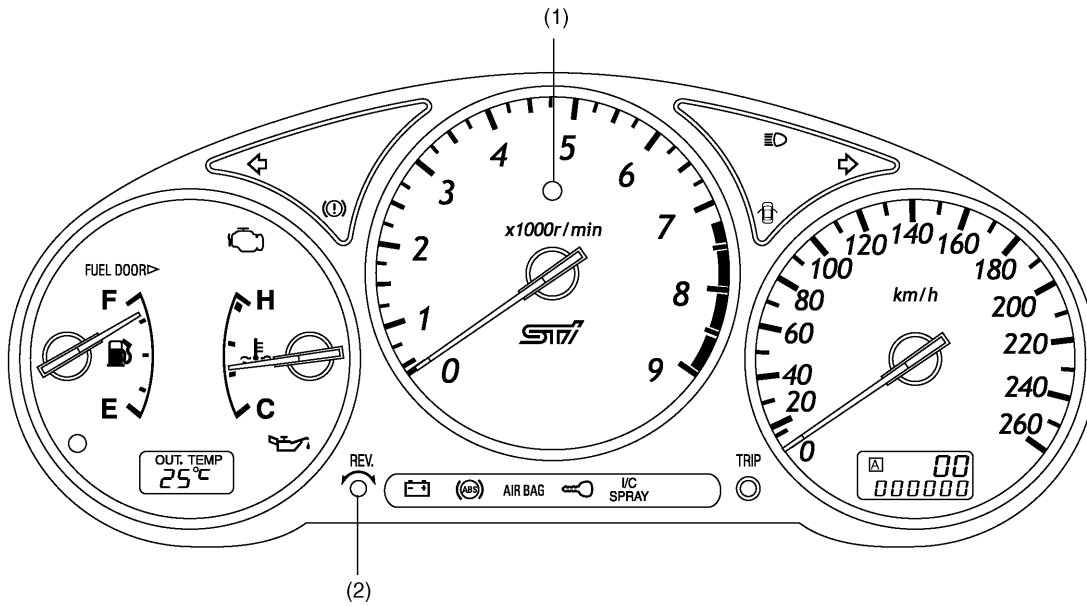

NF0594

(1) REV indicator light

(2) REV indicator setting knob