

Brought to you by Eris Studios
NOT FOR RESALE

COMMUNICATION SYSTEM

Brought to you by Eris Studios
NOT FOR RESALE

1. General Description

A: CAUTION

- Before disassembling or reassembling parts, always disconnect the battery ground cable. When replacing radio, control module, and other parts provided with memory functions, record memory contents before disconnecting the battery ground cable. Otherwise, the memory will be erased.
- Reassemble in reverse order of disassembly, unless otherwise indicated.
- Adjust parts to the given specifications.
- Connect the connectors and hoses securely during reassembly.
- After reassembly, make sure functional parts operate smoothly.

B: PREPARATION TOOL

1. GENERAL TOOLS

TOOL NAME	REMARKS
Circuit Tester	Used for measuring resistance and voltage.

2. Horn System

A: SCHEMATIC

1. HORN

<Ref. to WI-122, SCHEMATIC, Horn System.>

B: INSPECTION

1. HORN RELAY

Measure the horn relay resistance between terminals (indicated in table below) when connecting the terminal No. 4 to battery positive terminal and terminal No. 3 to battery ground cable.

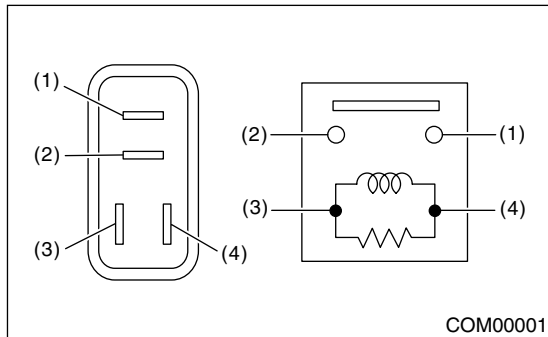

Current	Terminal No.	Standard
Flow	1 and 2	Less than 1 Ω
No Flow		More than 1 M Ω

3. Horn

A: REMOVAL

- 1) Disconnect the ground cable from battery.
- 2) Remove the horn bracket mounting bolt (A).
- 3) Disconnect the harness connector and remove the horn assembly (B).

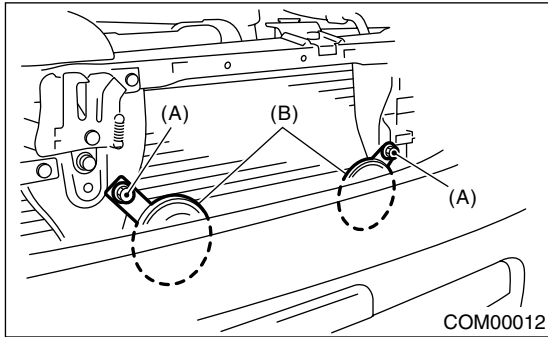

B: INSTALLATION

Install in the reverse order of removal.

C: INSPECTION

With 12 V direct current supplied between horn terminal and case ground, check that the horn sounds properly.

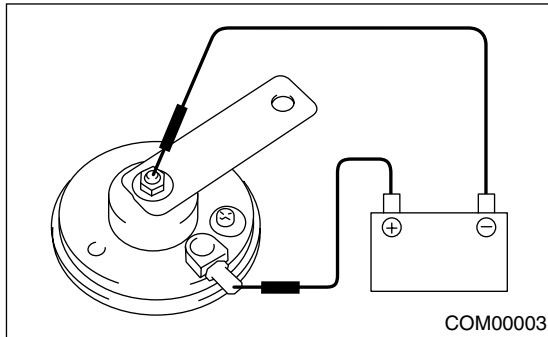

4. Horn Switch

A: REMOVAL

WARNING:

Before servicing, be sure to read the notes in AB section for proper handling of driver airbag module. <Ref. to AB-3, CAUTION, General Description.>

- 1) Disconnect the ground cable from battery.
- 2) Remove the driver's airbag module. <Ref. to AB-12, Driver's Airbag Module.>
- 3) Remove the horn switch from steering wheel as shown in the figure.

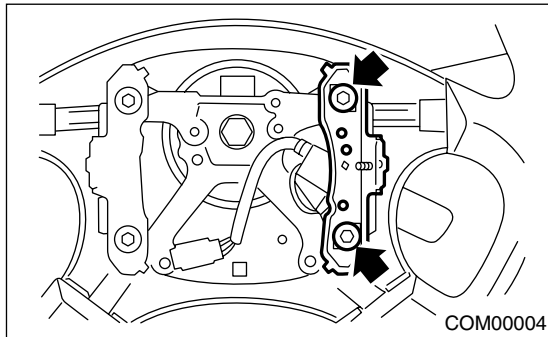

B: INSTALLATION

Install in the reverse order of removal.

C: INSPECTION

Measure the horn switch resistance.

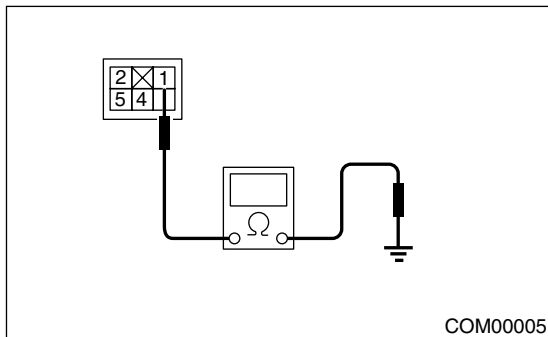

Switch position	Terminal No.	Resistance
When horn switch is pushed.	1 and Body ground	Less than 1 Ω
When horn switch is not pushed.		More than 1 MΩ

Brought to you by Eris Studios
NOT FOR RESALE