

Brought to you by Eris Studios
NOT FOR RESALE

INSTRUMENTATION DRIVER INFO

GENERAL DESCRIPTION

INSTRUMENTATION/DRIVER INFO

1. General Description

A: SPECIFICATIONS

	Model	Except STi model	STi model
Combination meter	Speedometer	Electric pulse type	Stepping motor type
	Temperature gauge	Cross coil type	Stepping motor type
	Fuel gauge	Cross coil type	Stepping motor type
	Tachometer	Electric pulse type	Stepping motor type
	Turn signal indicator light	14 V — 1.4 W	LED
	Charge indicator light	14 V — 1.4 W	LED
	Oil pressure indicator light		LED
	ABS warning light		LED
	Malfunction indicator light		LED
	HI-beam indicator light	14 V — 1.4 W	LED
	Door open warning light		LED
	Seat belt warning light		LED
	Brake fluid and parking brake warning light	14 V — 1.4 W	LED
	FWD indicator light	LED	—
	AIRBAG warning light		LED
	Meter illumination light	14 V — 3 W, 14 V — 2 W	LED
	AT OIL TEMP. warning light	LED	—
	Security indicator light		LED
	Cruise set indicator light	14 V — 1.4 W	LED
	Cruise indicator light	14 V — 1.4 W	LED
	Low fuel warning light		LED
	AT select lever position indicator light	14 V — 100 mA	—
	Intercooler water spray warning light	—	LED
	Rear differential oil temperature warning light	—	LED
	Driver's control center differential indicator light	—	LED
	REV indicator light	—	LED
	Headlight indicator light	—	LED
	LCD back light	14 V — 1.4 W	LED

B: CAUTION

- Be careful not to damage the meters and instrument panel.
- Be careful not to damage the meter glasses.
- Make sure that electrical connector is connected securely.

- After installation, make sure that each meter operates normally.
- Use gloves to avoid damage and getting fingerprints on the glass surface and meter surfaces.
- Do not apply excessive force to the printed circuit.
- Do not drop or otherwise apply impact.

C: PREPARATION TOOL

1. GENERAL TOOLS

TOOL NAME	REMARKS
Circuit Tester	Used for measuring resistance and voltage.

COMBINATION METER SYSTEM

INSTRUMENTATION/DRIVER INFO

2. Combination Meter System

A: SCHEMATIC

1. COMBINATION METER

<Ref. to WI-64, SCHEMATIC, Combination Meter.>

2. OUTSIDE TEMPERATURE INDICATOR

<Ref. to WI-145, SCHEMATIC, Outside Temperature Display System.>

B: INSPECTION

CAUTION:

When measuring voltage and resistance of the ECM, TCM, or each sensor, use a tapered pin with a diameter of less than 0.64 mm (0.025 in) in order to avoid poor contact. Do not insert the pin more than 2 mm (0.08 in).

1. SYMPTOM CHART

Symptom	Repair order	Reference
Combination meter assembly does not operate.	(1) Power supply (2) Ground circuit	<Ref. to IDI-4, CHECK POWER SUPPLY AND GROUND CIRCUIT, INSPECTION, Combination Meter System.>
Speedometer does not operate.	(1) Vehicle speed sensor (MT model) TCM (AT model) (2) Harness (3) Speedometer	MT model: <Ref. to IDI-4, CHECK VEHICLE SPEED SENSOR, INSPECTION, Combination Meter System.>
		AT model: <Ref. to IDI-5, CHECK TRANSMISSION CONTROL MODULE (TCM), INSPECTION, Combination Meter System.>
Tachometer does not operate.	(1) ECM (2) Harness (3) Tachometer	<Ref. to IDI-6, CHECK ENGINE CONTROL MODULE (ECM), INSPECTION, Combination Meter System.>
Fuel gauge does not operate.	(1) Fuel level sensor (2) Harness (3) Fuel gauge	<Ref. to IDI-6, CHECK FUEL LEVEL SENSOR, INSPECTION, Combination Meter System.>
Water temperature gauge does not operate.	(1) Engine coolant temperature sensor (2) Harness (3) Water temperature gauge	<Ref. to IDI-7, CHECK ENGINE COOLANT TEMPERATURE SENSOR, INSPECTION, Combination Meter System.>
Outside temperature indicator does not operate.	(1) Ambient sensor (2) Harness (3) Combination meter (4) Auto A/C control unit	<Ref. to IDI-8, CHECK OUTSIDE TEMPERATURE INDICATOR, INSPECTION, Combination Meter System.>

COMBINATION METER SYSTEM

INSTRUMENTATION/DRIVER INFO

2. CHECK POWER SUPPLY AND GROUND CIRCUIT

Step	Check	Yes	No
1 CHECK POWER SUPPLY FOR COMBINATION METER. 1)Remove the combination meter. <Ref. to IDI-10, REMOVAL, Combination Meter Assembly.> 2)Disconnect the combination meter harness connector. 3)Turn the ignition switch to ON. 4)Measure the voltage between combination meter connector and chassis ground. Connector & terminal <i>(i11) No. 7 (+) — Chassis ground (-):</i>	Is the voltage more than 10 V?	Go to step 2.	Check the harness for open or short between ignition switch and combination meter.
2 CHECK POWER SUPPLY FOR COMBINATION METER. Measure the voltage between combination meter connector and chassis ground. Connector & terminal <i>(i11) No. 10 (+) — Chassis ground (-):</i>	Is the voltage more than 10 V?	Go to step 3.	Check the harness for open or short between fuse and combination meter.
3 CHECK GROUND CIRCUIT OF COMBINATION METER. 1)Turn the ignition switch to OFF. 2)Measure the resistance of harness between combination meter connector and chassis ground. Connector & terminal <i>(i11) No. 6 — Chassis ground:</i>	Is the resistance less than 10 Ω?	Except STi model: Replace the combination meter printed circuit. STi model: Replace the meter main assembly.	Repair the wiring harness.

3. CHECK VEHICLE SPEED SENSOR

Step	Check	Yes	No
1 CHECK VEHICLE SPEED SENSOR. 1)Lift-up the vehicle and support it with safety stands. 2)Remove the combination meter with harness connector. 3)Drive the vehicle at a speed greater than 20 km/h (12 MPH). Warning: Be careful not to get caught in the running wheels. 4)Measure the voltage between combination meter connector and chassis ground. Connector & terminal <i>(i11) No. 2 (+) — Chassis ground (-):</i>	Is the voltage less than 1 V ←→ more than 5 V?	Except STi model: Check the speedometer. <Ref. to IDI-13, REMOVAL, Speedometer.> STi model: Replace the meter main assembly.	Go to step 2.
2 CHECK VEHICLE SPEED SENSOR POWER SUPPLY. 1)Turn the ignition switch to OFF. 2)Disconnect the vehicle speed sensor harness connector. 3)Turn the ignition switch to ON. 4)Measure the voltage between vehicle speed sensor connector and engine ground. Connector & terminal <i>(B17) No. 3 (+) — Chassis ground (-):</i>	Is the voltage more than 10 V?	Go to step 3.	Check the harness for open or short between ignition switch and vehicle speed sensor.

COMBINATION METER SYSTEM

INSTRUMENTATION/DRIVER INFO

Step	Check	Yes	No	
3	CHECK HARNESS BETWEEN VEHICLE SPEED SENSOR AND ENGINE GROUND. 1) Turn the ignition switch to OFF. 2) Measure the resistance between vehicle speed sensor connector and engine ground. <i>Connector & terminal</i> <i>(B17) No. 2 — Chassis ground:</i>	Is the resistance less than 10 Ω?	Go to step 4.	Repair the wiring harness.
4	CHECK HARNESS BETWEEN VEHICLE SPEED SENSOR AND COMBINATION METER. 1) Disconnect the connector from combination meter. 2) Measure the resistance between vehicle speed sensor harness connector and combination meter harness connector. <i>Connector & terminal</i> <i>(B17) No. 1 — (i11) No. 2:</i>	Is the resistance less than 10 Ω?	Replace the vehicle speed sensor.	Repair the wiring harness.

4. CHECK TRANSMISSION CONTROL MODULE (TCM)

Step	Check	Yes	No	
1	CHECK TCM SIGNAL. 1) Lift-up the vehicle and support it with safety stands. 2) Drive the vehicle faster than 10 km/h (6 MPH). Warning: Be careful not to get caught in the running wheels. 3) Measure the voltage between TCM connector and chassis ground. <i>Connector & terminal</i> <i>Non-turbo model:</i> <i>(B55) No. 13 (+) — Chassis ground (-):</i> <i>Turbo model:</i> <i>(B56) No. 17 (+) — Chassis ground (-):</i>	Is the voltage less than 1 V ←→ more than 5 V?	Go to step 2.	Check the TCM. <Ref. to 4AT-2, Basic Diagnostic Procedure.>
2	CHECK HARNESS BETWEEN TCM AND COMBINATION METER. 1) Turn the ignition switch to OFF. 2) Disconnect the connector from TCM and combination meter. 3) Measure the resistance between TCM harness connector and combination meter harness connector. <i>Connector & terminal</i> <i>Non-turbo model:</i> <i>(B55) No. 13 — (i11) No. 2:</i> <i>Turbo model:</i> <i>(B56) No. 17 — (i11) No. 2:</i>	Is the resistance less than 10 Ω?	Check the speed meter. <Ref. to IDI-13, REMOVAL, Speedometer.>	Repair the wiring harness.

COMBINATION METER SYSTEM

INSTRUMENTATION/DRIVER INFO

5. CHECK ENGINE CONTROL MODULE (ECM)

Step	Check	Yes	No
1 CHECK ECM SIGNAL. 1) Start the engine. 2) Measure the voltage between ECM connector and engine ground. Connector & terminal Non-turbo model: (B134) No. 10 (+) — Chassis ground (-): Turbo model: (B137) No. 9 (+) — Chassis ground (-): STi model: (B134) No. 23 (+) — Chassis ground (-):	Is the voltage 0 ↔ 14 V or more?	Go to step 2.	Check the ECM. <Ref. to EN(H4SO)-2, Basic Diagnostic Procedure.> or <Ref. to EN(H4DOTC)-2, Basic Diagnostic Procedure.> or <Ref. to EN(STi) section.>
2 CHECK HARNESS BETWEEN COMBINATION METER AND ECM. 1) Turn the ignition switch to OFF. 2) Disconnect the connector from ECM and combination meter. 3) Measure the resistance between ECM harness connector and combination meter harness connector. Connector & terminal Non-turbo model: (B134) No. 10 — (i11) No. 5: Turbo model: (B137) No. 9 — (i11) No. 5: STi model: (B134) No. 23 — (i11) No. 5:	Is the resistance less than 10 Ω?	Except STi model: Check the tachometer. <Ref. to IDI-14, REMOVAL, Tachometer.> STi model: Replace the meter main assembly.	Repair the wiring harness.

6. CHECK FUEL LEVEL SENSOR

Step	Check	Yes	No
1 CHECK FUEL LEVEL SENSOR. 1) Remove the fuel level sensor. <Ref. to FU(H4SO)-58, REMOVAL, Fuel Level Sensor.>, <Ref. to FU(H4DOTC)-62, REMOVAL, Fuel Level Sensor.> or <Ref. to FU(STi) section.> 2) Measure the resistance between fuel level sensor terminals when setting the float to FULL and EMPTY position. Terminals No. 2 — No. 3:	Is the resistance 0.5 to 2.5 Ω (FULL) and 50 to 52 Ω (EMPTY)?	Go to step 2.	Replace the fuel level sensor.
2 CHECK FUEL SUB LEVEL SENSOR. 1) Remove the fuel sub level sensor. <Ref. to FU(H4SO)-59, REMOVAL, Fuel Sub Level Sensor.>, <Ref. to FU(H4DOTC)-63, REMOVAL, Fuel Sub Level Sensor.> or <Ref. to FU(STi) section.> 2) Measure the resistance between fuel sub level sensor terminals when setting the float to FULL and EMPTY position. Terminals No. 1 — No. 2:	Is the resistance 0.5 to 2.5 Ω (FULL) and 42 to 44 Ω (EMPTY)?	Go to step 3.	Replace the fuel sub level sensor.

COMBINATION METER SYSTEM

INSTRUMENTATION/DRIVER INFO

Step	Check	Yes	No
3 CHECK HARNESS BETWEEN FUEL SUB LEVEL SENSOR AND COMBINATION METER. 1) Disconnect the connector from combination meter. 2) Measure the resistance between fuel sub level sensor harness connector terminal and combination meter harness connector terminal. <i>Connector & terminal</i> <i>(R59) No. 1 — (i12) No. 2:</i>	Is the resistance less than 10 Ω ?	Go to step 4.	Repair the wiring harness.
4 CHECK HARNESS BETWEEN FUEL LEVEL SENSOR AND FUEL SUB LEVEL SENSOR. Measure the resistance between fuel level sensor harness connector terminal and fuel sub level sensor harness connector terminal. <i>Connector & terminal</i> <i>(R58) No. 3 — (R59) No. 2:</i>	Is the resistance less than 10 Ω ?	Go to step 5.	Repair the wiring harness.
5 CHECK FUEL LEVEL SENSOR GROUND CIRCUIT. Measure the resistance between fuel level sensor harness connector terminal and chassis ground. <i>Connector & terminal</i> <i>(R58) No. 2 — Chassis ground:</i>	Is the resistance less than 10 Ω ?	Except STi model: Check the fuel gauge. <Ref. to IDI-15, REMOVAL, Fuel Gauge.> STi model: Replace the meter main assembly.	Repair the wiring harness.

7. CHECK ENGINE COOLANT TEMPERATURE SENSOR

Step	Check	Yes	No
1 CHECK ENGINE COOLANT TEMPERATURE SENSOR. Check the engine coolant temperature sensor. <Ref. to EN(H4SO)-2, Basic Diagnostic Procedure.> or <Ref. to EN(H4DOTC)-2, Basic Diagnostic Procedure.> or <Ref. to EN(STi) section.>	Is the engine coolant temperature sensor OK?	Go to step 2.	Replace the engine coolant temperature sensor.
2 CHECK HARNESS BETWEEN ENGINE COOLANT TEMPERATURE SENSOR AND COMBINATION METER. 1) Turn the ignition switch to OFF. 2) Disconnect the connector from engine coolant temperature sensor and combination meter. 3) Measure the resistance between engine coolant temperature sensor harness connector and combination meter harness connector. <i>Connector & terminal</i> <i>(E8) No. 3 — (i12) No. 9:</i>	Is the resistance less than 10 Ω ?	Except STi model: Check the water temperature gauge. <Ref. to IDI-16, REMOVAL, Water Temperature Gauge.> STi model: Replace the meter main assembly.	Repair the wiring harness.

COMBINATION METER SYSTEM

INSTRUMENTATION/DRIVER INFO

8. CHECK OUTSIDE TEMPERATURE INDICATOR

Step	Check	Yes	No
1	CHECK AIR CONDITIONER TYPE.	Go to step 6.	Go to step 2.
2	CHECK POWER SUPPLY FOR AMBIENT SENSOR. 1) Turn the ignition switch to OFF. 2) Disconnect the connector from combination meter. 3) Turn the ignition switch to ON. 4) Measure the voltage between combination meter terminal and chassis ground. Connector & terminal (i10) No. 11 (+) — Chassis ground (-):	Go to step 3.	Replace the combination meter printed circuit.
3	CHECK HARNESS BETWEEN AMBIENT SENSOR AND COMBINATION METER. 1) Turn the ignition switch to OFF. 2) Disconnect the connector from ambient sensor. 3) Measure the resistance between ambient sensor harness connector terminal and combination meter harness connector terminal. Connector & terminal (F78) No. 1 — (i10) No. 11: (F78) No. 2 — (i10) No. 8:	Go to step 4.	Repair the wiring harness.
4	CHECK AMBIENT SENSOR. 1) Remove the ambient sensor. 2) Check the ambient sensor. <Ref. to IDI-17, INSPECTION, Ambient Sensor.>	Go to step 5.	Replace the ambient sensor.
5	CHECK OUTSIDE TEMPERATURE INDICATOR. 1) Connect the combination meter harness connector. 2) Connect a resistor (2.2 kΩ) between terminals of ambient sensor harness connector. 3) Turn the ignition switch to ON and check the outside temperature indicator display.	Repair the poor contact of ambient sensor harness connector.	Replace the combination meter printed circuit.
6	CHECK POWER SUPPLY FOR COMBINATION METER. 1) Turn the ignition switch to OFF. 2) Disconnect the connector from auto A/C control module. 3) Turn the ignition switch to ON. 4) Measure the voltage between auto A/C control module terminal and chassis ground. Connector & terminal (B282) No. 11 (+) — chassis ground (-):	Go to step 7.	Replace the auto A/C control module.
7	CHECK HARNESS BETWEEN AUTO A/C CONTROL MODULE AND COMBINATION METER. 1) Turn the ignition switch to OFF. 2) Disconnect the connector from combination meter. 3) Measure the resistance between auto A/C control module harness connector terminal and combination meter harness connector terminal. Connector & terminal (B282) No. 11 — (i10) No. 12:	Go to step 8.	Repair the wiring harness.

COMBINATION METER SYSTEM

INSTRUMENTATION/DRIVER INFO

Step	Check	Yes	No
8 CHECK POWER SUPPLY FOR AMBIENT SENSOR. 1) Turn the ignition switch to ON. 2) Measure the voltage between auto A/C control module terminal and chassis ground. <i>Connector & terminal</i> <i>(B283) No. 9 (+) — chassis ground (-):</i>	Is the voltage more than 4 V?	Go to step 9.	Replace the auto A/C control module.
9 CHECK HARNESS BETWEEN AMBIENT SENSOR AND COMBINATION METER. 1) Turn the ignition switch to OFF. 2) Disconnect the connector from ambient sensor. 3) Measure the resistance between ambient sensor harness connector terminal, combination meter harness connector terminal and auto A/C control module harness connector terminal. <i>Connector & terminal</i> <i>(F78) No. 1 — (i10) No. 11:</i> <i>(F78) No. 1 — (B283) No. 9:</i> <i>(F78) No. 2 — (i10) No. 8:</i>	Is the resistance less than 10 Ω ?	Go to step 10.	Repair the wiring harness.
10 CHECK AMBIENT SENSOR. 1) Remove the ambient sensor. 2) Check the ambient sensor. <Ref. to IDI-17, INSPECTION, Ambient Sensor.>	Is the ambient sensor OK?	Go to step 11.	Replace the ambient sensor.
11 CHECK OUTSIDE TEMPERATURE INDICATOR. 1) Connect the combination meter and auto A/C control module harness connector. 2) Connect a resistor (2.2 k Ω) between terminals of ambient sensor harness connector. 3) Turn the ignition switch to ON and check the outside temperature indicator display.	Is the outside temperature indicator indicating 25°C (77°F)?	Repair the poor contact of ambient sensor harness connector.	Replace the meter main assembly.

COMBINATION METER ASSEMBLY

INSTRUMENTATION/DRIVER INFO

3. Combination Meter Assembly

A: REMOVAL

- 1) Disconnect the ground cable from battery.
- 2) Set the tilt steering at lowest position.
- 3) Remove the screws and detach the meter visor.

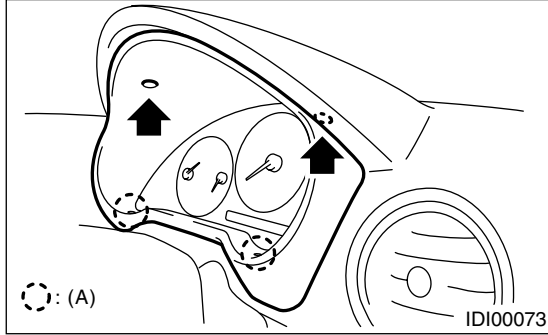

(A) Hook

- 4) Remove the screws of combination meter and pull out the meter toward you.

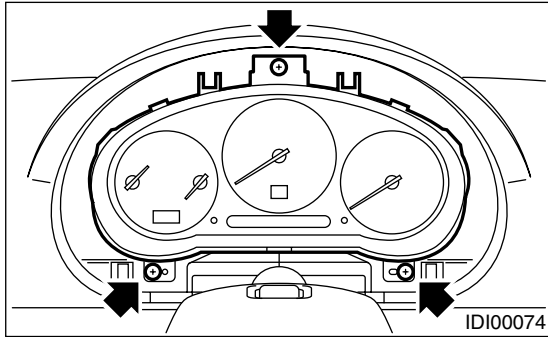

- 5) Disconnect the connector in the upper area of combination meter to remove the meter.

CAUTION:

- Be careful not to damage the meter or instrument panel.
- Pay particular attention to avoid damaging the meter glass.

B: INSTALLATION

Install in the reverse order of removal.

CAUTION:

- Make sure that electrical connector is connected securely.
- Make sure that each meter operates normally.

C: DISASSEMBLY

1. EXCEPT STi MODEL

CAUTION:

Use gloves to avoid damage and getting fingerprints on the glass surface and meter surfaces.

- 1) Disengage the claw (F) to remove the case (B) from back cover (A).
- 2) Disengage the claw (G) to remove the meter glass (E), reflector (D), and window plate (C) from inner case.

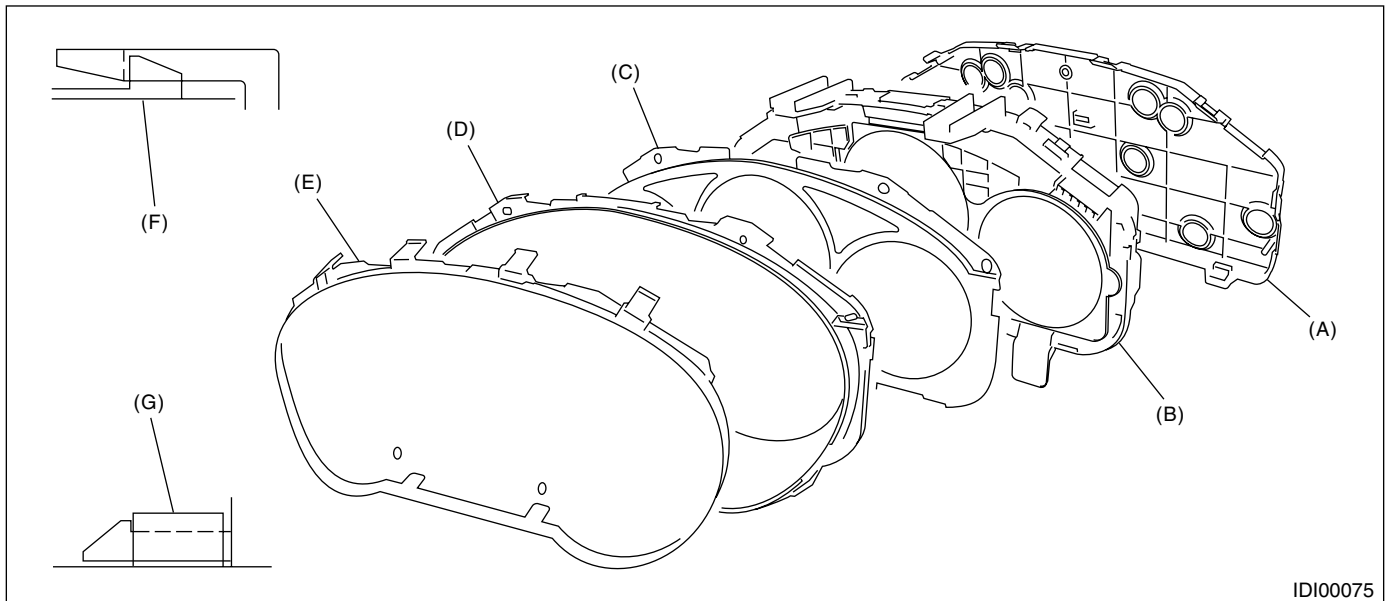

COMBINATION METER ASSEMBLY

INSTRUMENTATION/DRIVER INFO

- 3) Pull up the claw (A) in portion (B) of combination meter printed circuit (C) with combination pliers. Push out the speedometer and tachometer assembly (D) and fuel gauge and water temperature gauge assembly (E) using hole (F).
- 4) Pull up the claw in center of combination meter printed circuit (C), and remove the printed circuit from case (G).

2. STi MODEL

CAUTION:

Use gloves to avoid damage and getting fingerprints on the glass surface and meter surfaces.

Disengage the claw (E) to remove the meter glass (D), reflector (C), and window plate (B) from meter main assembly (A).

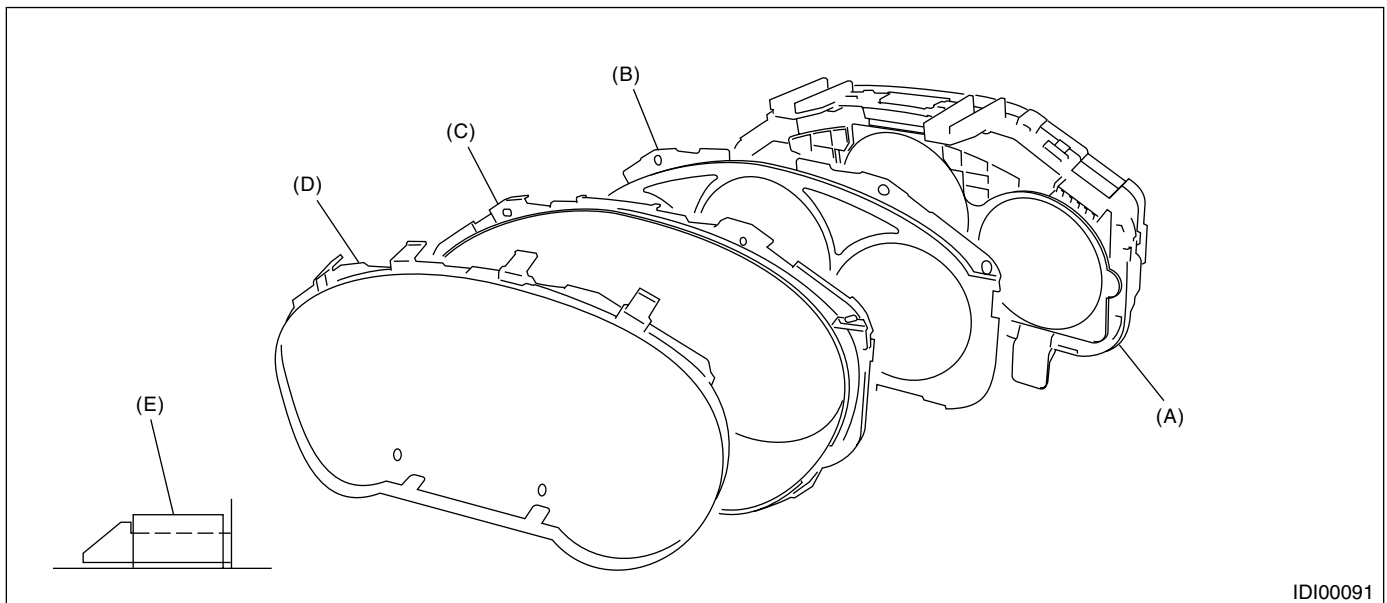
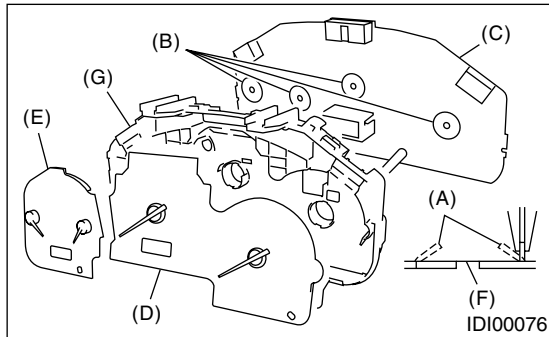

COMBINATION METER ASSEMBLY

INSTRUMENTATION/DRIVER INFO

3. BULB REPLACEMENT

• EXCEPT STi MODEL

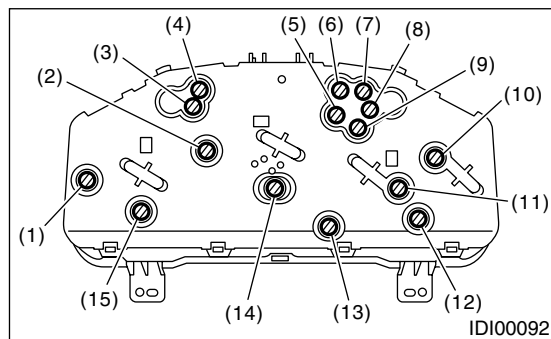

- (1) Tachometer (Non-turbo model) or speedometer (Turbo model)
- (2) Speedometer and tachometer
- (3) Turn signal indicator light (RH)
- (4) HI-beam indicator light
- (5) Speedometer (Non-turbo model) or tachometer (Turbo model)
- (6) Cruise set indicator light
- (7) Cruise indicator light
- (8) Turn signal indicator light (LH)
- (9) Brake fluid and parking brake warning light
- (10) Fuel gauge
- (11) Temperature gauge
- (12) LCD (Outside temperature indicator)
- (13) Charge warning light
- (14) LCD (Odometer and tripmeter: non-turbo model)
- (15) LCD (Odometer and tripmeter: turbo model)

• STi MODEL

Replace the meter main assembly of STi model if it does not function properly, because the warning light and indicator light are made from LED.

D: ASSEMBLY

Assemble in the reverse order of disassembly.

4. Speedometer

A: REMOVAL

NOTE:

Main meter assembly of STi model cannot be disassembled. Do not remove or inspect the speedometer as a single unit.

Disassemble the combination meter, and then remove the speedometer and tachometer assembly.
<Ref. to IDI-10, DISASSEMBLY, Combination Meter Assembly.>

B: INSTALLATION

Install in the reverse order of removal.

C: INSPECTION

Measure the speedometer resistance.

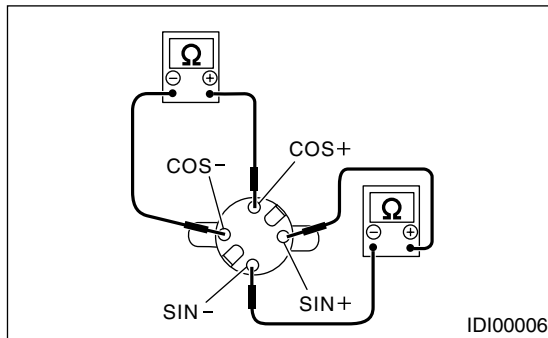

Terminal	Resistance
Terminals SIN+ and SIN-	200±8 Ω
Terminals COS+ and COS-	200±8 Ω

If NG, replace the speedometer and tachometer assembly.

If OK, replace the combination meter printed circuit.

Brought to you by Eris Studios
NOT FOR RESALE

5. Tachometer

A: REMOVAL

NOTE:

Main meter assembly of STi model cannot be disassembled. Do not remove or inspect the tachometer as a single unit.

Disassemble the combination meter, and then remove the speedometer and tachometer assembly. <Ref. to IDI-10, DISASSEMBLY, Combination Meter Assembly.>

B: INSTALLATION

Install in the reverse order of removal.

C: INSPECTION

Measure the tachometer resistance.

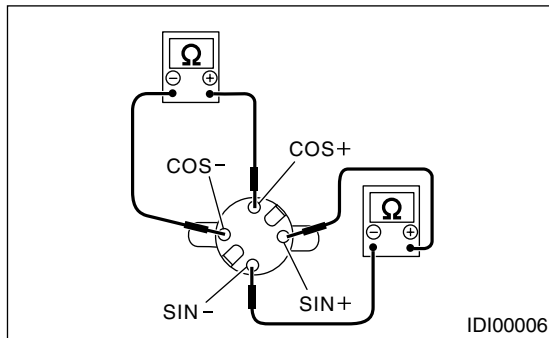

Terminal	Resistance
Terminals SIN+ and SIN-	200±8 Ω
Terminals COS+ and COS-	200±8 Ω

If NG, replace the speedometer and tachometer assembly.

If OK, replace the combination meter printed circuit.

6. Fuel Gauge

A: REMOVAL

NOTE:

Main meter assembly of STi model cannot be disassembled. Do not remove or inspect the fuel gauge as a single unit.

Disassemble the combination meter, and then remove the water temperature gauge and fuel gauge assembly. <Ref. to IDI-10, DISASSEMBLY, Combination Meter Assembly.>

B: INSTALLATION

Install in the reverse order of removal.

C: INSPECTION

Measure the fuel gauge resistance.

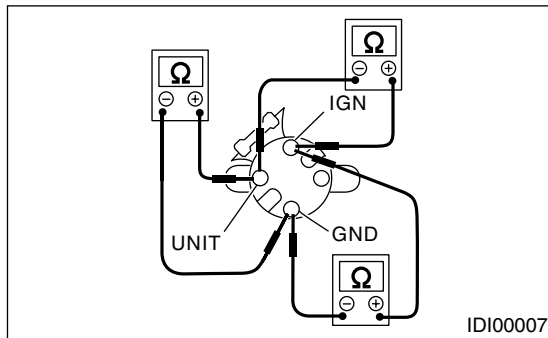

Terminal	Resistance
Terminals IGN and GND	$170 \pm 10 \Omega$
Terminals IGN and UNIT	$35 \pm 10 \Omega$
Terminals UNIT and GND	$136 \pm 10 \Omega$

If NG, replace the water temperature gauge and fuel gauge assembly.

If OK, replace the combination meter printed circuit.

WATER TEMPERATURE GAUGE

INSTRUMENTATION/DRIVER INFO

7. Water Temperature Gauge

A: REMOVAL

NOTE:

Main meter assembly of STi model cannot be disassembled. Do not remove or inspect the water temperature gauge as a single unit.

Disassemble the combination meter, and then remove the tachometer and water temperature gauge and fuel gauge assembly. <Ref. to IDI-10, DISASSEMBLY, Combination Meter Assembly.>

B: INSTALLATION

Install in the reverse order of removal.

C: INSPECTION

Measure the water temperature gauge resistance.

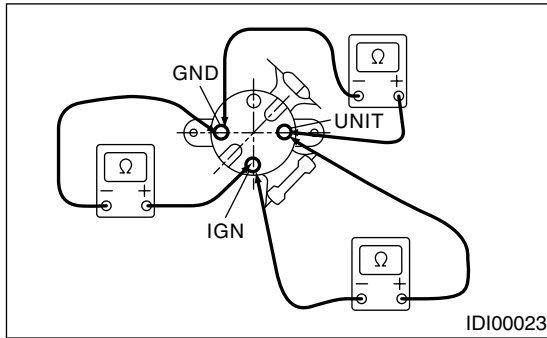

Terminal	Resistance
Terminals IGN and GND	$208 \pm 10 \Omega$
Terminals IGN and UNIT	$56 \pm 10 \Omega$
Terminals UNIT and GND	$264 \pm 10 \Omega$

If NG, replace the water temperature gauge and fuel gauge assembly.

If OK, replace the combination meter printed circuit.

8. Ambient Sensor

A: REMOVAL

- 1) Disconnect the ground cable from battery.
- 2) Disconnect the ambient sensor connector.
- 3) Remove the ambient sensor (A) from radiator lower panel.

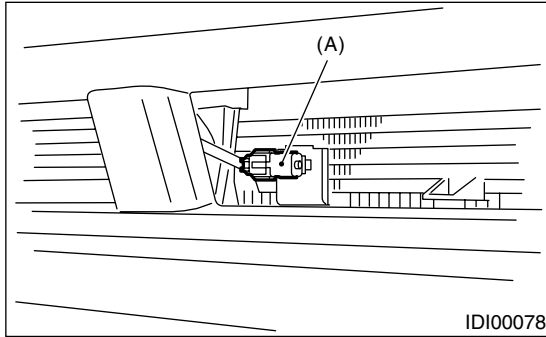

B: INSTALLATION

Install in the reverse order of removal.

C: INSPECTION

Measure the ambient sensor resistance.

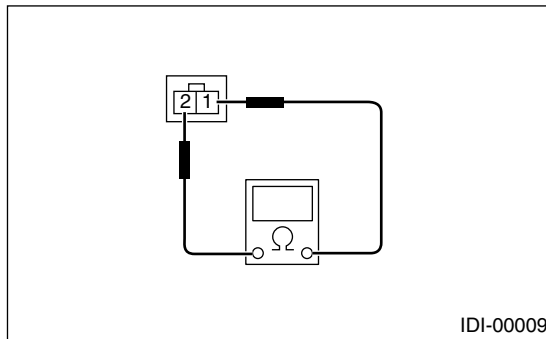

Terminal	Resistance
1 and 2	2.2 kΩ/25°C (77°F)

If NG, replace the ambient sensor.

Brought to you by Eris Studios
NOT FOR RESALE